

ENGINEERING TEST REPORT

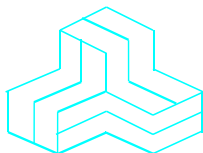

Onsight Rugged Smart Camera

Model No.: 5000HD

FCC ID: T78-5000HD

IC: 6656A-5000HD

Tested For

Librestream Technologies

895 Waverly Street, Suite 110
Winnipeg, Manitoba
Canada. R3T 5P4

In accordance with

**SAR (Specific Absorption Rate) Requirements using guidelines established in
IEEE C95.1-1992, FCC OET Bulletin 65 (Supplement C) and Industry Canada RSS-102 (Issue 5)
EN 50360 (Council Recommendation 1999/519/EC)
ARPANSA Radio Protection Series Publication No. 3
EN 50566:2013 & EN 62479:2010**

UltraTech's File No.: LIBT-073Q

This Test report is Issued under the Authority of
Tri M. Luu, BAsC,
Vice President of Engineering
UltraTech Group of Labs

Date: April 3, 2012

Report Prepared by:
Maxavier Kee

Issued Date:
February 20th, 2017

Tested by:
Maxavier Kee
Test Dates:
January 26 ~ Feb 14th, 2017

The results in this Test Report apply only to the sample(s) tested, which has been randomly selected.

UltraTech Group of Labs

3000 Bristol Circle, Oakville, Ontario, Canada, L6H 6G4
Tel.: (905) 829-1570 Fax.: (905) 829-8050

Website: www.ultratech-labs.com, Email: vic@ultratech-labs.com, Email: tri@ultratech-labs.com



91038



1309



46390-2049



AT-1945



SL2-IN-E-1119R



Korea
KCC-RRA
CA2049

TABLE OF CONTENTS

EXHIBIT 1. INTRODUCTION	1
1.1. SCOPE.....	1
1.2. REFERENCES	2
EXHIBIT 2. PERFORMANCE ASSESSMENT.....	3
2.1. CLIENT AND MANUFACTURER INFORMATION	3
2.2. DEVICE UNDER TEST (D.U.T.) DESCRIPTION	4
2.2.1. Photographs of D.U.T.....	5
2.3. LIST OF D.U.T.'S ACCESSORIES:	11
2.4. SPECIFIC OPERATING AND TEST CONDITIONS	12
2.4.1. Switched Diversity Transmission Conditions.....	12
2.4.2. Simultaneous Transmission Conditions.....	13
2.4.3. Test Channel Selection.....	15
EXHIBIT 3. SUMMARY OF TEST RESULTS	19
3.1. LOCATION OF TESTS	19
3.2. APPLICABILITY & SUMMARY OF SAR RESULTS	19
3.2.1. 2.45GHz Reported SAR for standalone transmissions (scaled).....	20
3.2.2. 5.5 GHz Reported SAR for standalone transmissions (scaled).....	21
3.2.3. 5.5 GHz Reported SAR for Mimo and Diversity Antenna1 and Antenna2 (scaled).....	24
3.3. DASY5 SYSTEM OVERVIEW.....	25
3.3.1. DASY5 System Specification.....	25
3.3.2. DASY5 SAR SYSTEM block diagram.....	28
3.4. SAR TEST PHANTOMS.....	29
3.4.1. SAM Twin Phantom.....	29
3.4.2. ELI 4.0 Phantom.....	29
EXHIBIT 4. SAR DATA ACQUISITION METHODOLOGY	30
4.1. SAR MEASUREMENT PROCEDURE.....	30
4.1.1. Interpolation, Extrapolation and Detection of Maxima.....	32
4.1.2. Averaging and Determination of Spatial Peak SAR	33
4.1.3. Evaluation Errors	33
EXHIBIT 5. MEASUREMENTS, EXAMINATIONS & TEST DATA.....	35
5.1. TEST CONFIGURATIONS	35
5.1.1. Wifi 802.11 a/b/g/n 2450 MHz.....	35
5.1.2. Wifi 802.11 a/b/g/n 5200-5825 MHz.....	36
5.2. GENERAL TEST SETUP	37
5.2.1. Equipment Configuration.....	37
5.2.2. Exercising Equipment	37
5.3. PHOTOGRAPHS OF TISSUE DEPTH.....	38
5.4. PHOTOGRAPHS OF D.U.T. POSITION.....	39
5.4.1. Body Configuration for EUT Top Side Exposure	39
5.4.2. Body Configuration for Back Side Exposure	40
5.4.3. Body Configuration for Front Side Exposure	41
5.4.4. EUT Alignment with Phantom and Probe coordinates for maximum SAR Top Side Exposure	42
EXHIBIT 6. SAR MEASUREMENT SYSTEM VERIFICATION	43
6.1. STANDARD SOURCE.....	43

ULTRATECH GROUP OF LABS

3000 Bristol Circle, Oakville, Ontario, Canada L6H 6G4
Tel. #: 905-829-1570, Fax. #: 905-829-8050, Email: vic@ultratech-labs.com, Website: <http://www.ultratech-labs.com>

File #: LIB-073Q-SAR

February 20, 2017

- All test results contained in this engineering test report are traceable to National Institute of Standards and Technology (NIST)

6.2.	STANDARD SOURCE INPUT POWER MEASUREMENT	44
6.3.	SYSTEM VALIDATION PROCEDURE	44
6.4.	VERIFICATION RESULTS	45
6.4.1.	<i>Reference Dipole SAR measurements</i>	45
6.4.2.	<i>Verification at 2450 MHz</i>	46
6.4.3.	<i>Verification at 5200 MHz</i>	48
6.4.4.	<i>Verification at 5400 MHz</i>	50
6.4.5.	<i>Verification at 5600 MHz</i>	52
6.4.6.	<i>Verification at 5800 MHz</i>	54
EXHIBIT 7.	D.U.T. POWER MEASUREMENT	56
7.1.1.	<i>RF Conducted output power measurement</i>	57
EXHIBIT 8.	TISSUE DIELECTRIC PARAMETER CALIBRATION	59
8.1.	SIMULATED TISSUE	59
8.2.	MEASUREMENT OF ELECTRICAL CHARACTERISTICS OF SIMULATED TISSUE	60
8.2.1.	<i>Equipment set-up</i>	60
8.2.2.	<i>Measurement procedure</i>	61
8.3.	SIMULATED TISSUE MEASUREMENT RESULTS	62
8.3.1.	<i>2450 MHz Muscle Tissue</i>	62
8.3.2.	<i>5500 MHz Muscle Tissue</i>	62
EXHIBIT 9.	SAR MEASUREMENT UNCERTAINTY	63
9.1.	MEASUREMENT UNCERTAINTY EVALUATION FOR SAR TEST	63
EXHIBIT 10.	ADDITIONAL TEST INSTRUMENTS LIST	64
EXHIBIT 11.	SAR MEASUREMENT DATA	64
EXHIBIT 12.	PROBE CALIBRATION CERTIFICATE.....	64
EXHIBIT 13.	VALIDATION DIPOLE CALIBRATION CERTIFICATE	ERROR! BOOKMARK NOT DEFINED.

EXHIBIT 1. INTRODUCTION

1.1. SCOPE

Reference:	SAR (Specific Absorption Rate) Requirements IEEE C95.1-2005, FCC OET Bulletin 65 (Supplement C Edition 01-01) Industry Canada RSS-102 (Issue 5).
Title	Safety Levels with respect to human exposure to Radio Frequency Electromagnetic Fields Guideline for Evaluating the Environmental Effects of Radio Frequency Radiation
Purpose of Test:	To verify compliance with Federal regulated SAR requirements in Canada and the US.
Method of Measurements:	IEEE C95.1-2005, FCC OET Bulletin 65 (Supplement C Edition 01-01) and Industry Canada RSS-102 (Issue 5)
Device Category	Portable
Exposure Category	General/un-controlled

ULTRATECH GROUP OF LABS

3000 Bristol Circle, Oakville, Ontario, Canada L6H 6G4
Tel. #: 905-829-1570, Fax. #: 905-829-8050, Email: vic@ultratech-labs.com, Website: <http://www.ultratech-labs.com>

File #: LIB-073Q-SAR

February 20, 2017

- All test results contained in this engineering test report are traceable to National Institute of Standards and Technology (NIST)

1.2. REFERENCES

The methods and procedures used for the measurements contained in this report are details in the following reference standards:

Publications	Year	Title
IEEE Std. 1528	2013	Draft Recommended practice for determining the Peak Spatial-Average Specific Absorption rate (SAR) in the Human Body Due to Wireless Communications Devices: Experimental Techniques.
Industry Canada RSS-102	2015	“Evaluation Procedure for Mobile and Portable Radio Transmitters with respect to Health Canada’s Safety Code 6 for Exposure of Humans to Radio Frequency Fields”
NCRP Report No.86	1986	“Biological Effects and Exposure Criteria for radio Frequency Electromagnetic Fields”
FCC OET Bulletin 65	2001	“Evaluating Compliance with FCC Guidelines for Human Exposure to radio Frequency Fields”
ANSI/IEEE C95.3	2002	“Recommended Practice for the Measurement of Potentially Hazardous Electromagnetic Fields - RF and Microwave”
ANSI/IEEE C95.1	2005	“Safety Levels with Respect to Human Exposure to Radio Frequency Electromagnetic Fields, 3kHz to 300GHz”
ARPANSA	2002	RADIATION PROTECTION STANDARD Maximum Exposure Levels to Radiofrequency Fields — 3 kHz to 300 GHz Radiation Protection Series Publication No. 3
EN 50566	2013	Product standard to demonstrate compliance of radio frequency fields from handheld and body-mounted wireless communication devices used by the general public (30 MHz - 6 GHz)
EN 62479	2010	Assessment of the compliance of low power electronic and electrical equipment with the basic restrictions related to human exposure to electromagnetic fields (10 MHz to 300 GHz)
IEC 62209-2	2010	Human exposure to radio frequency fields from hand-held and body-mounted wireless communication devices – Human models, instrumentation, and procedures – Part 2: Procedure to determine the specific absorption rate (SAR) for wireless communication devices used in close proximity to the human body (frequency range of 30 MHz to 6 GHz)
FCC KDB	2017	865664 D01 SAR Measurement 100 MHz to 6 GHz v01r04 248227 D01 802.11 Wi-Fi SAR v02r02 648474 D04 Handset SAR v01r02 447498 D01 General RF Exposure Guidance v06 447498 D03 Supplement C Cross-Reference 388624 D02 Pre-Approval Guidance List v16r02 865664 D02 RF Exposure Reporting v01r01 690783 D01 SAR Listings on Grants v01r0
Health Canada’s Safety Code 6	2015	Limits of Human Exposure to Radiofrequency Electromagnetic Energy in the Frequency Range from 3 kHz to 300 GHz

ULTRATECH GROUP OF LABS

3000 Bristol Circle, Oakville, Ontario, Canada L6H 6G4
 Tel. #: 905-829-1570, Fax. #: 905-829-8050, Email: vic@ultratech-labs.com, Website: <http://www.ultratech-labs.com>

File #: LIB-073Q-SAR

February 20, 2017

- All test results contained in this engineering test report are traceable to National Institute of Standards and Technology (NIST)

EXHIBIT 2. PERFORMANCE ASSESSMENT

2.1. CLIENT AND MANUFACTURER INFORMATION

APPLICANT:	
Name:	Librestream Technologies, Inc.
Address:	895 Waverley Street, Suite 110 Winnipeg, Manitoba Canada, R3T 5P4
Contact Person:	Mr. Gilles Aminot Phone #: +1.204.487.0612 ext 218 Fax #: +1.204.487.0914 Email Address: gilles.aminot@librestream.com

MANUFACTURER:	
Name:	Librestream Technologies, Inc.
Address:	895 Waverley Street, Suite 110 Winnipeg, Manitoba Canada, R3T 5P4
Contact Person:	Mr. Gilles Aminot Phone #: +1.204.487.0612 ext 218 Fax #: +1.204.487.0914 Email Address: gilles.aminot@librestream.com

ULTRATECH GROUP OF LABS

3000 Bristol Circle, Oakville, Ontario, Canada L6H 6G4
Tel. #: 905-829-1570, Fax. #: 905-829-8050, Email: vic@ultratech-labs.com, Website: <http://www.ultratech-labs.com>

File #: LIB-073Q-SAR

February 20, 2017

- All test results contained in this engineering test report are traceable to National Institute of Standards and Technology (NIST)

2.2. DEVICE UNDER TEST (D.U.T.) DESCRIPTION

The following is the information provided by the applicant.

Trade Name	Librestream Technologies, Inc.
Product Description	Rugged Mobile Collaboration Device
Type/Model Number	5000HD
Frequency of Operation	2412 ~ 2462 MHz; 5180MHz ~ 5850MHz
Maximum RF Output Power	802.11b: 16.5dBm average conducted 802.11g: 18.0dBm average conducted 802.11a: 18.0dBm average conducted 802.11n: 18.0dBm average conducted
Modulation Employed	802.11b: DBPSK(1Mbps), DQPSK(2Mbps), CCK(5.5/11Mbps) 802.11g: OFDM(6M-54Mbps) 802.11a: BPSK, QPSK, 16QAM, 64QAM 802.11n: BPSK, QPSK, 16QAM, 64QAM
Antenna	Wifi Antennas (Diversity and MIMO): Laird Technologies EMM00119-RE1 D-Puck – Front Antenna 1 Antenova SR42W001 – Top Antenna 2 NFC Antenna PCB Trace – custom 13.56MHz GPS Antenna (Receiver Only): Antenova SR4G008
Power Supply	External Power Supply Adapter: 120/230Vac 50/60 Hz (AC/DC Adaptor, CUI Inc, M/N: 3A-181WP12) Integrated Li-Ion Battery (7.2VDC, 2400mAh)
Primary User Functions of D.U.T.	Provide hand held wireless video and audio data communication

ULTRATECH GROUP OF LABS

3000 Bristol Circle, Oakville, Ontario, Canada L6H 6G4
Tel. #: 905-829-1570, Fax. #: 905-829-8050, Email: vic@ultratech-labs.com, Website: <http://www.ultratech-labs.com>

File #: LIB-073Q-SAR

February 20, 2017

- All test results contained in this engineering test report are traceable to National Institute of Standards and Technology (NIST)

2.2.1. Photographs of D.U.T



< Front View >

ULTRATECH GROUP OF LABS

3000 Bristol Circle, Oakville, Ontario, Canada L6H 6G4
Tel. #: 905-829-1570, Fax. #: 905-829-8050, Email: vic@ultratech-labs.com, Website: <http://www.ultratech-labs.com>

File #: LIB-073Q-SAR
February 20, 2017

- All test results contained in this engineering test report are traceable to National Institute of Standards and Technology (NIST)



< Back View >

ULTRATECH GROUP OF LABS

3000 Bristol Circle, Oakville, Ontario, Canada L6H 6G4
Tel. #: 905-829-1570, Fax. #: 905-829-8050, Email: vic@ultratech-labs.com, Website: <http://www.ultratech-labs.com>

File #: LIB-073Q-SAR
February 20, 2017

- All test results contained in this engineering test report are traceable to National Institute of Standards and Technology (NIST)



< Top View >

ULTRATECH GROUP OF LABS

3000 Bristol Circle, Oakville, Ontario, Canada L6H 6G4
Tel. #: 905-829-1570, Fax. #: 905-829-8050, Email: vic@ultratech-labs.com, Website: <http://www.ultratech-labs.com>

File #: LIB-073Q-SAR
February 20, 2017

- All test results contained in this engineering test report are traceable to National Institute of Standards and Technology (NIST)



< Bottom View >

ULTRATECH GROUP OF LABS

3000 Bristol Circle, Oakville, Ontario, Canada L6H 6G4
Tel. #: 905-829-1570, Fax. #: 905-829-8050, Email: vic@ultratech-labs.com, Website: <http://www.ultratech-labs.com>

File #: LIB-073Q-SAR
February 20, 2017

- All test results contained in this engineering test report are traceable to National Institute of Standards and Technology (NIST)



< Right Side View >

ULTRATECH GROUP OF LABS

3000 Bristol Circle, Oakville, Ontario, Canada L6H 6G4
Tel. #: 905-829-1570, Fax. #: 905-829-8050, Email: vic@ultratech-labs.com, Website: <http://www.ultratech-labs.com>

File #: LIB-073Q-SAR
February 20, 2017

- All test results contained in this engineering test report are traceable to National Institute of Standards and Technology (NIST)



< Left Side View >

ULTRATECH GROUP OF LABS

3000 Bristol Circle, Oakville, Ontario, Canada L6H 6G4
Tel. #: 905-829-1570, Fax. #: 905-829-8050, Email: vic@ultratech-labs.com, Website: <http://www.ultratech-labs.com>

File #: LIB-073Q-SAR

February 20, 2017

- All test results contained in this engineering test report are traceable to National Institute of Standards and Technology (NIST)

2.3. LIST OF D.U.T.'S ACCESSORIES:

Onsight 5000HD Body Worn Accessories List:

- Shoulder strap that attaches via tripod mount
Examples:



- All test results contained in this engineering test report are traceable to National Institute of Standards and Technology (NIST)

2.4. SPECIFIC OPERATING AND TEST CONDITIONS

Device under tests supporting:

- WiFi 802.11abgn
- Bluetooth BLE
- NFC – 13.56MHz
- GPS Receiver

Radio Features

- 20MHz and 40MHz SISO and 20-MHz 2 x 2 MIMO at 2.4 GHz for High Throughput
- 2.4-GHz MRC Support for Extended Range and 5-GHz (SISO) Diversity Capable

2.4GHz Wifi Tx Modes

Antenna 1 only (SISO)

Supported Modes

- 802.11b, DSSS, 1,2,5.5,11Mbps (2.4GHz)
- 802.11g, OFDM, 6,9,12,18,24,36,48,54 (2.4GHz)
- 802.11n, OFDM, 20MHz, MSC0-7
- 802.11n, OFDM, 40MHz, MSC0 and MSC7

Antenna 1 + Antenna 2 (MIMO)

Supported Modes

- 802.11n, OFDM, MSC12-MSC14

5GHz Wifi Tx Modes

Ant1 or Ant2 (SISO - Diversity)

Supported Modes

- 802.11a, OFDM 6,9,12,18,36,48,54 (5GHz)
- 802.11n, OFDM, 20MHz, MCS0-MCS7
- 802.11n, OFDM, 40MHz, MCS0 and MCS7

2.4GHz Bluetooth

Antenna 1 only

The device is a hand-held high definition video streaming device used in video conferencing and remote consulting sessions. The device's primary operating mode is intended to be used in a hand-held extended position in front of an operator or mounted on a fixed supporting camera tripod. It is not designed to be used in close proximity to the head or body of an operator. The device does come with a neck strap option which connects to the mounting point at the base of the unit for carrying purposes and this is the main next-to-body exposure condition considered in this setup. FCC KDB 248227 D01 802.11 Wi-Fi SAR v02r02 test reduction will be followed to reduce the number of SAR scans required to determine compliance.

2.4.1. Switched Diversity Transmission Conditions

The device supports switched diversity and since energy is dispersed both temporally and spatially, with only one antenna transmitting at a time, the reported SAR of the antennas are averaged to determine compliance. Both measured and reported SAR for all diversity antennas are required in the SAR report to support compliance.

ULTRATECH GROUP OF LABS

3000 Bristol Circle, Oakville, Ontario, Canada L6H 6G4
Tel. #: 905-829-1570, Fax. #: 905-829-8050, Email: vic@ultratech-labs.com, Website: <http://www.ultratech-labs.com>

File #: LIB-073Q-SAR

February 20, 2017

- All test results contained in this engineering test report are traceable to National Institute of Standards and Technology (NIST)

2.4.2. Simultaneous Transmission Conditions

The device supports mimo Wifi 802.11 abgn transmissions and these two antennae are to provide spatial and frequency diversity. Antenna 1 is located on the front of the device beside the front camera lens. Antenna 2 is located on top left side of the device near the left hand held position of the device. The top antenna 2 supports Wifi 802.11 abgn while the front antenna 1 supports Wifi 802.11 abgn and/or BLE transmissions. The NFC antenna is separate from the mimo antenna and is located near the back under the battery. The top Antenna 2 location will provide the highest SAR exposure condition as the antenna is located on the devices top and back edge of the device with the smooth surfaces allowing for a 0mm separation distance to the phantom surface. The front Antenna 1 does not allow for a 0mm antenna to phantom separation distance and is not considered to be a major exposure condition but will be investigated nonetheless. Contributions to the top and back exposure from the front Antenna 1 will be conducted in the post processing analysis to address the diversity concerns.

Supported positions:

- 1) Neck/Shoulder Strap: WiFi (data) + Bluetooth (data & voice) +NFC
- 2) Held in hand: WiFi (data) + Bluetooth (data & voice) +NFC
- 3) Too large to fit inside pocket: Device is too large to fit into pocket and this mode is not supported.

SAR for body exposure was tested with the EUT.

- Positions for Body exposure for the Front antenna was Front of the EUT against the phantom with 0 mm air gap.
- Positions for Body exposure for the Top antenna was Top and Back side of the EUT against the phantom with 0 mm air gap.

The headphone was excluded for the top surface exposure to ensure the minimum separation distance of 0mm.

WLAN is tested on the channel with the highest measured average conducted power

SAR evaluation of 802.11g and 802.11n channels is not required when the maximum average output power is less than 0.25dB higher than the measured corresponding 802.11a and 802.11n channels.

The Bluetooth (+4.9mW FCC Grant Listing) transmissions and 9mm front Antenna 1 separation distance are below the test exclusion threshold and SAR evaluation is not required under FCC KDB 447498 and FCC KDB 648474. According to FCC KDB 447498 and FCC KDB 648474, simultaneous SAR evaluation is not required because the sum of 1g SAR values measured for all simultaneous transmitting antennas is less than 1.6W/kg limit.

The NFC (13.56MHz) transmissions are outside the scope of SAR evaluation procedures and standards.

2.4.3. RSS-102 2.5.1 Exemption Limits for Routine Evaluation

Separation Distances (mm)	Exemption Limits 2450 MHz (mW)
0	0.00
5	4.00
9	5.72
10	7.00
15	15.00
20	30.00
25	52.00
30	83.00
35	123.00
40	173.00
45	235.00
50	309.00

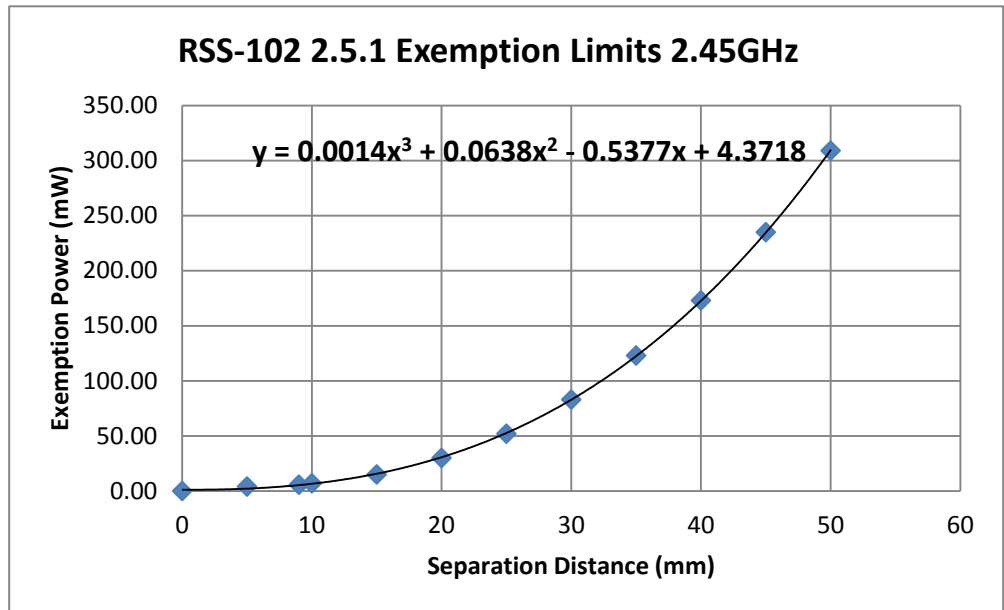

2.4.4. FCC KDB 447498 D01 General RF Exposure Guidance v06 - Appendix A

Separation Distances (mm)	Exclusion Thresholds Limits 2450 MHz (mW)	Calculated Thresholds 2450 MHz (mW)
0	0.00	0.00
5	10.00	9.58
9	17.29	17.25
10	19.00	19.17
15	29.00	28.75
20	38.00	38.33
25	48.00	47.92
30	57.00	57.50
35	67.00	67.08
40	77.00	76.67
45	86.00	86.25
50	96.00	95.83

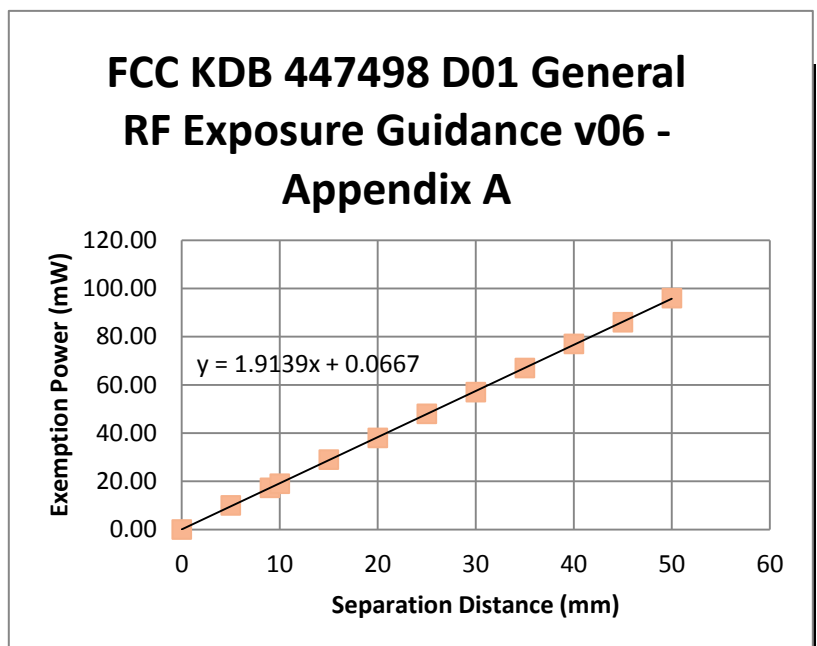

ULTRATECH GROUP OF LABS

3000 Bristol Circle, Oakville, Ontario, Canada L6H 6G4
 Tel. #: 905-829-1570, Fax. #: 905-829-8050, Email: vic@ultratech-labs.com, Website: <http://www.ultratech-labs.com>

File #: LIB-073Q-SAR
 February 20, 2017

- All test results contained in this engineering test report are traceable to National Institute of Standards and Technology (NIST)

2.4.5. Test Channel Selection

GHz	Chan	Turbo Chan	Default Test Channels - Antenna 2											
			15.247								UNII			
			802.11b		802.11g		802.11n (Mimo)		802.11a		802.11n			
			Rated	Meas	Rated	Meas	Rated	Meas	Filed	Meas	Filed	Meas		
2412	1		18	18.60	18	18.53	20	19.45	N/A	N/A	N/A	N/A		
2437	6	6	18	18.00	18	19.42	20	19.89	N/A	N/A	N/A	N/A		
2462	11		18	17.83	18	18.81	20	19.57	N/A	N/A	N/A	N/A		
5180	36		N/A	N/A	N/A	N/A	N/A	N/A	15.71	15.84	15.54	15.66		
5200	40	42(5.21GHz)	N/A	N/A	N/A	N/A	N/A	N/A		15.27		15.23		
5220	44		N/A	N/A	N/A	N/A	N/A	N/A	15.82	15.36	15.53	15.26		
5240	48	50(5.25GHz)	N/A	N/A	N/A	N/A	N/A	N/A	15.56	15.06	15.48	14.56		
5260	52		N/A	N/A	N/A	N/A	N/A	N/A	13.3	13.62	13.44	13.87		
5280	56	58(5.29GHz)	N/A	N/A	N/A	N/A	N/A	N/A		13.85		13.76		
5300	60		N/A	N/A	N/A	N/A	N/A	N/A	13.48	13.88	13.87	13.95		
5320	64		N/A	N/A	N/A	N/A	N/A	N/A	13.28	13.34	13.37	13.51		
5500	100	Unknown	N/A	N/A	N/A	N/A	N/A	N/A	14.52	14.66	14.93	14.63		
5520	104		N/A	N/A	N/A	N/A	N/A	N/A		14.90		15.64		
5540	108		N/A	N/A	N/A	N/A	N/A	N/A		15.50		16.15		
5560	112		N/A	N/A	N/A	N/A	N/A	N/A		16.22		16.33		
5580	116		N/A	N/A	N/A	N/A	N/A	N/A	18.44	16.89	17.52	16.30		
5600	120		N/A	N/A	N/A	N/A	N/A	N/A		16.80		16.09		
5620	124		N/A	N/A	N/A	N/A	N/A	N/A		16.95		16.71		
5640	128		N/A	N/A	N/A	N/A	N/A	N/A		16.69		16.35		
5660	132		N/A	N/A	N/A	N/A	N/A	N/A		16.71		16.50		
5680	136		N/A	N/A	N/A	N/A	N/A	N/A		17.05		16.41		
5700	140		N/A	N/A	N/A	N/A	N/A	N/A	11.94	11.78	12.19	12.21		
5745	149			N/A	N/A	N/A	N/A	N/A	N/A	12.82	10.25	12.72	10.51	
5765	153	152(5.76GHz)	N/A	N/A	N/A	N/A	N/A	N/A		15.21		14.67		
5785	157		N/A	N/A	N/A	N/A	N/A	N/A	17.88	14.66	17.56	14.45		
5805	161	160(5.8GHz)	N/A	N/A	N/A	N/A	N/A	N/A		14.41		14.12		
5.825	165		N/A	N/A	N/A	N/A	N/A	N/A	14.03	13.87	13.87	12.83		

2.4.6. Interior Photos showing Antenna locations

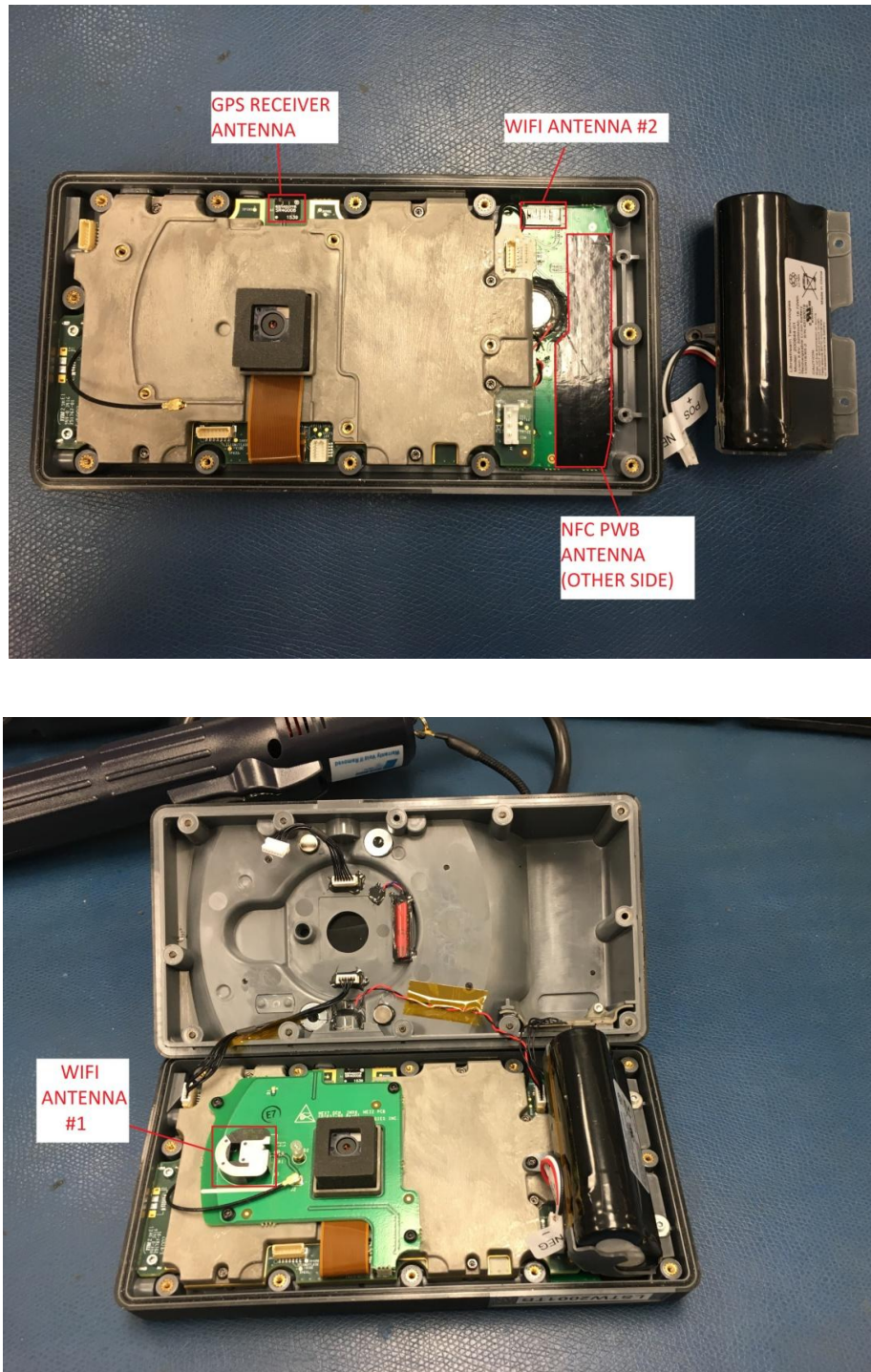

Figure 1 Antenna Locations Internal to Device

ULTRATECH GROUP OF LABS

3000 Bristol Circle, Oakville, Ontario, Canada L6H 6G4
Tel. #: 905-829-1570, Fax. #: 905-829-8050, Email: vic@ultratech-labs.com, Website: <http://www.ultratech-labs.com>

File #: LIB-073Q-SAR
February 20, 2017

- All test results contained in this engineering test report are traceable to National Institute of Standards and Technology (NIST)

2.4.7. CAD files showing Antenna separation distances

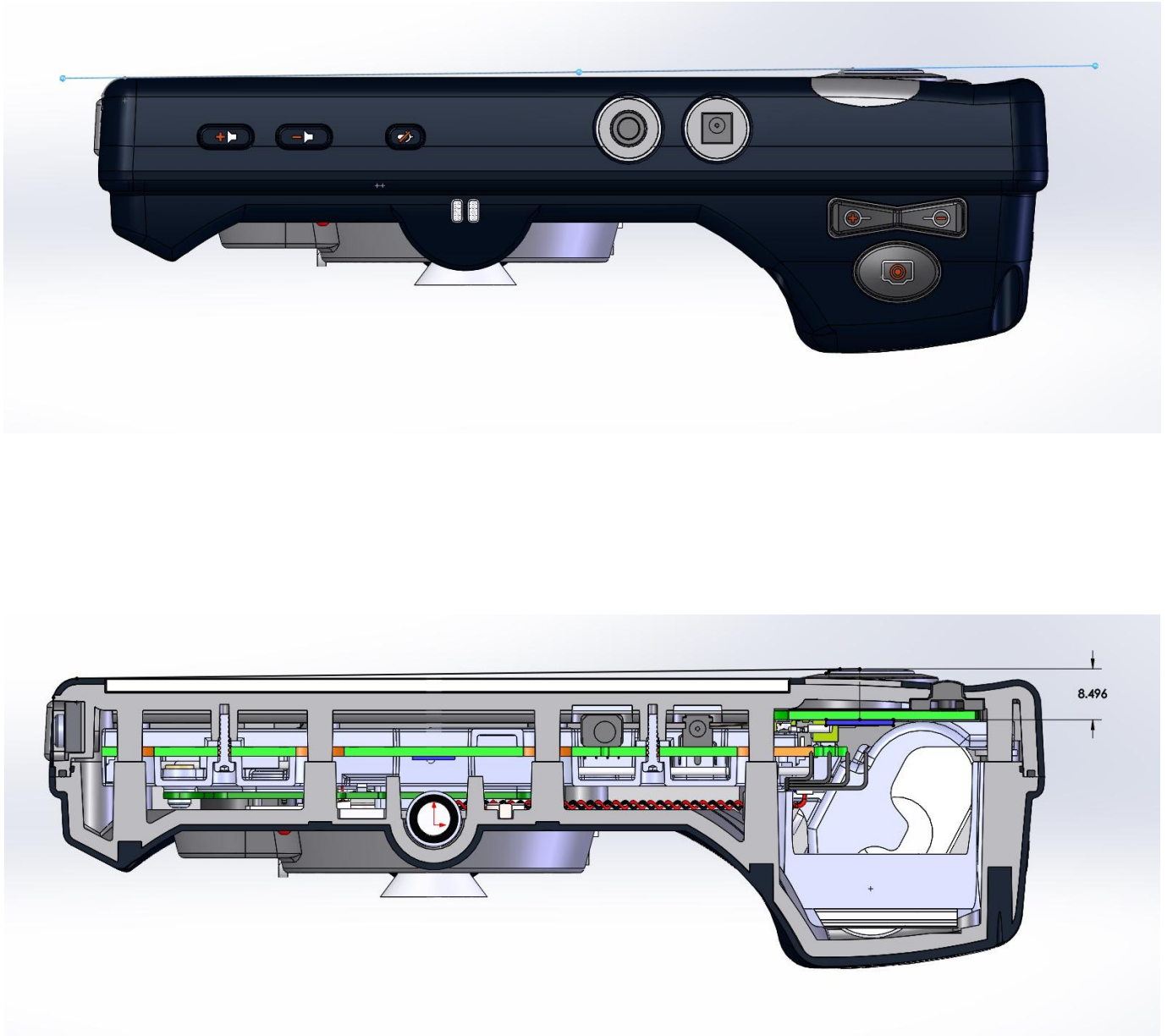

Figure 2 Top Antenna 2 - Separation Distance to back touch plane

ULTRATECH GROUP OF LABS

3000 Bristol Circle, Oakville, Ontario, Canada L6H 6G4
Tel. #: 905-829-1570, Fax. #: 905-829-8050, Email: vic@ultratech-labs.com, Website: <http://www.ultratech-labs.com>

File #: LIB-073Q-SAR
February 20, 2017

- All test results contained in this engineering test report are traceable to National Institute of Standards and Technology (NIST)

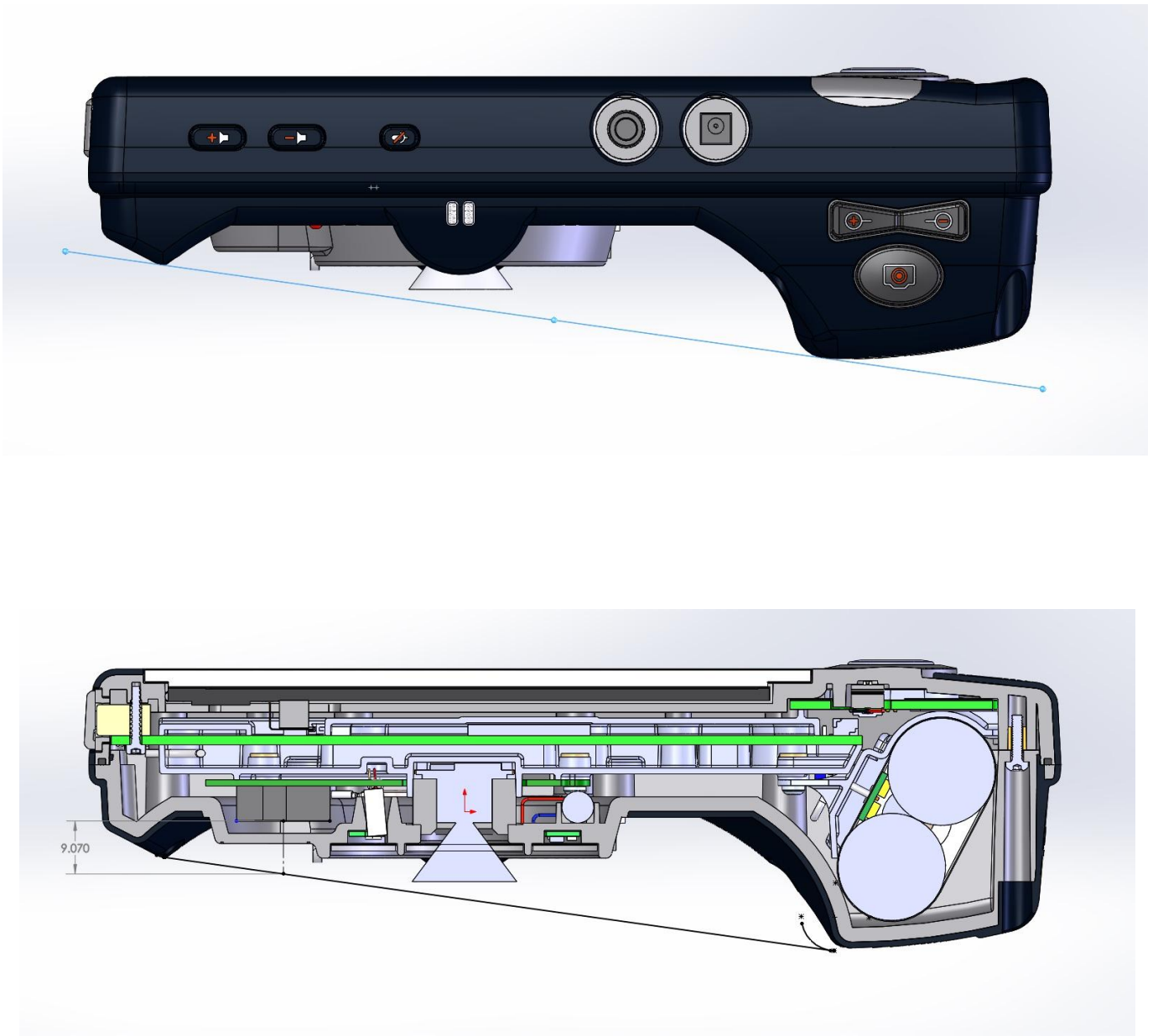

Figure 3 Front Antenna 1 - Separation distance to front touch plane

ULTRATECH GROUP OF LABS

3000 Bristol Circle, Oakville, Ontario, Canada L6H 6G4
Tel. #: 905-829-1570, Fax. #: 905-829-8050, Email: vic@ultratech-labs.com, Website: <http://www.ultratech-labs.com>

File #: LIB-073Q-SAR
February 20, 2017

- All test results contained in this engineering test report are traceable to National Institute of Standards and Technology (NIST)

EXHIBIT 3. SUMMARY OF TEST RESULTS

3.1. LOCATION OF TESTS

All of the measurements described in this report were performed at UltraTech Group of Labs located at: 3000 Bristol Circle, in the city of Oakville, Province of Ontario, Canada.

All measurements were performed in UltraTech's shielded chamber, 16' x 13' x 8'.

3.2. APPLICABILITY & SUMMARY OF SAR RESULTS

SAR LIMITS - GENERAL POPULATION					
	Australia ACA	North America ANSIC95.1	Europe ENV50166	Japan TTC/MPT	New Zealand NZS2772
Whole Body	0.08 W/kg	0.08 W/kg	0.08 W/kg	0.04 W/kg	0.08 W/kg
Spatial Peak	2 W/kg	1.6 W/kg	2 W/kg	2 W/kg	2 W/kg
Extremities	4.0 W/Kg	4.0 W/Kg	4.0 W/Kg	4.0 W/Kg	4.0 W/Kg
Averaging Time	6 min	30 min	6 min	6 min	6 min
Averaging Time	10g	1g	10g	10g	10g
Shape	Cube	Cube	Cube	Cube	Cube

The maximum peak spatial – 1g average SAR reported was found to be 1.190 W/Kg for body configuration.

The maximum peak spatial – 10g average SAR reported was found to be 0.354 W/Kg for body configuration.

The worst case peak spatial – 1g average SAR for Simultaneous transmissions was calculated to be 1.317 W/Kg for body configuration.

The worst case peak spatial – 10g average SAR for Simultaneous transmissions was calculated to be 0.378 W/Kg for body configuration.

3.2.1. 2.45GHz Reported¹ SAR for standalone transmissions (scaled)

		Channel (MHz)	802.11b		802.11g		802.11n		Maximums	
			SAR1g (mW/g)	SAR10g (mW/g)	SAR1g (mW/g)	SAR10g (mW/g)	SAR1g (mW/g)	SAR10g (mW/g)	SAR1g (mW/g)	SAR10g (mW/g)
2450 MHz	Antenna 2 Back	2,412	0.360	0.145					0.506	0.371
		2,437	0.506	0.205	0.371	0.147	0.070	0.027		
		2,462	0.448	0.179						
	Antenna 2 Top	2,412	0.346	0.137					0.381	0.293
		2,437	0.304	0.123	0.293	0.117	0.051	0.019		
		2,462	0.381	0.148						
	Antenna 1 Front	2,412							0.071	0.039
		2,437	0.071	0.039						
		2,462								

¹ Reported SAR is scaled to maximum tune-up RF power

3.2.2. 5.5 GHz Reported² SAR for standalone transmissions (scaled)

	Channel (MHz)	802.11a		802.11n		Maximums	
		SAR1g (mW/g)	SAR10g (mW/g)	SAR1g (mW/g)	SAR10g (mW/g)	SAR1g (mW/g)	SAR10g (mW/g)
Antenna 2 Back	5,180	0.827	0.252			1.190	0.354
	5,220	0.960	0.293				
	5,240	0.939	0.297				
	5,300	0.963	0.304				
	5,500	0.817	0.224				
	5,540	0.782	0.210				
	5,580	0.847	0.229				
	5,620	0.598	0.163				
	5,660	0.739	0.202				
	5,765	1.190	0.354				
5,805	1.140	0.344					
Antenna 2 Top	5,180	0.752	0.210			1.140	0.311
	5,220	0.768	0.214				
	5,240	1.020	0.290				
	5,260	0.841	0.236	0.972	0.272		
	5,280	1.010	0.277	1.010	0.280		
	5,300	1.120	0.306	1.030	0.285		
	5,320	1.140	0.311	0.890	0.245		
	5,500	0.971	0.241				
	5,540	0.954	0.248				
	5,580	0.892	0.230				
	5,620	0.558	0.146				
	5,660	0.546	0.146				
	5,765	0.805	0.258				
	5,805	0.872	0.279				

² Reported SAR is scaled to maximum tune-up RF power

	Channel (MHz)	802.11a		802.11n		Maximums	
		SAR1g (mW/g)	SAR10g (mW/g)	SAR1g (mW/g)	SAR10g (mW/g)	SAR1g (mW/g)	SAR10g (mW/g)
Antenna 1 Front	5,180	0.457	0.159			0.507	0.171
	5,220	0.507	0.162				
	5,240	0.472	0.146				
	5,300	0.389	0.123				
	5,320	0.414	0.129				
	5,500	0.264	0.082				
	5,540	0.271	0.084				
	5,580	0.305	0.091				
	5,620	0.266	0.080				
	5,660	0.274	0.082				
	5,765	0.425	0.132				
	5,805	0.456	0.171				
Antenna 1 Top	5,180	0.177	0.067			0.177	0.067
	5,220						
	5,240						
	5,260						
	5,280						
	5,300	0.100	0.014				
	5,320	0.096	0.036				
	5,540						
	5,580						
	5,620						
	5,660						
	5,765						
5,805							

ULTRATECH GROUP OF LABS

3000 Bristol Circle, Oakville, Ontario, Canada L6H 6G4
 Tel. #: 905-829-1570, Fax. #: 905-829-8050, Email: vic@ultratech-labs.com, Website: <http://www.ultratech-labs.com>

File #: LIB-073Q-SAR
 February 20, 2017

- All test results contained in this engineering test report are traceable to National Institute of Standards and Technology (NIST)

	Channel (MHz)	802.11a		802.11n		Maximums	
		SAR1g (mW/g)	SAR10g (mW/g)	SAR1g (mW/g)	SAR10g (mW/g)	SAR1g (mW/g)	SAR10g (mW/g)
Antenna 1 Back	5,180	0.024	0.007			0.052	0.015
	5,220	<0.001	<0.001				
	5,240	<0.001	<0.001				
	5,300	0.052	0.015				
	5,500	0.003	0.000				
	5,540	<0.001	<0.001				
	5,580	<0.001	<0.001				
	5,620	<0.001	<0.001				
	5,660	<0.001	<0.001				
	5,765	<0.001	<0.001				
	5,805	<0.001	<0.001				
Antenna 2 Front	5,180					0.019	0.006
	5,220	0.019	0.006				
	5,240						
	5,300						
	5,320						
	5,500						
	5,540						
	5,580						
	5,620						
	5,660						
	5,765						
	5,805						

ULTRATECH GROUP OF LABS

3000 Bristol Circle, Oakville, Ontario, Canada L6H 6G4
 Tel. #: 905-829-1570, Fax. #: 905-829-8050, Email: vic@ultratech-labs.com, Website: <http://www.ultratech-labs.com>

File #: LIB-073Q-SAR
 February 20, 2017

- All test results contained in this engineering test report are traceable to National Institute of Standards and Technology (NIST)

3.2.3. 5.5 GHz Reported³ SAR for MIMO and Diversity Antenna1 and Antenna2 (scaled)

The Top Antenna2 resulted in providing the highest measured SAR in the touch positions of the flat phantom and contributions from the Front Antenna1 in these exposure modes were analyzed in post processing and the hot spots were found to be non-overlapping.

As a conservative estimate, the highest measured SAR from both Antennas may be combined to provide a worst case estimate with the following results;

	Device Top Exposure		Device Back Exposure	
	SAR1g	SAR10g	SAR1g	SAR10g
Antenna 1	1.14	0.311	1.19	0.354
Antenna 2	0.177	0.067	0.019	0.006
Diversity - Average SAR	0.6585	0.189	0.6045	0.18
MIMO - Combined SAR	1.317	0.378	1.209	0.36

³ Reported SAR is scaled to maximum tune-up RF power

SAR SYSTEM CONFIGURATION

3.3. DASY5 SYSTEM OVERVIEW

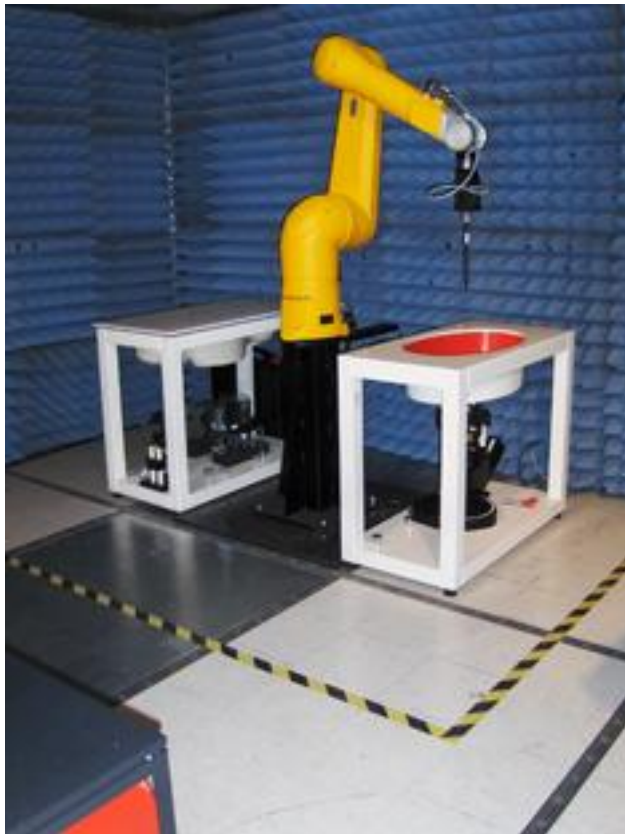

3.3.1. DASY5 System Specification

Positioning Equipment	Computer
DASY5 Measurement Server Data Acquisition Electronics (DAE) Light Beam Unit Device Holder Robot (STAUBLI TX90)	Type: HP Compaq dc7800p Convertible CPU : Intel® Core™ 2 Duo E8500 Memory : 2GB RAM Operating System : Windows XP Professional Monitor : HP L1950g LCD

3.3.1.1. DASY5 Measurement Server

The DASY5 measurement server is based on a PC/104 CPU board with a 400MHz Intel ULV Celeron, 128MB chipdisk and 128MB RAM. The necessary circuits for communication with the DAE4 (or DAE3) electronics box, as well as the 16 bit AD converter system for optical detection and digital I/O interface are contained on the DASY5 I/O board, which is directly connected to the PC/104 bus of the CPU board.

The measurement server performs all real-time data evaluation of field measurements and surface detection, controls robot movements and handles safety operation. The PC operating system cannot interfere with these time critical

ULTRATECH GROUP OF LABS

3000 Bristol Circle, Oakville, Ontario, Canada L6H 6G4
 Tel. #: 905-829-1570, Fax. #: 905-829-8050, Email: vic@ultratech-labs.com, Website: <http://www.ultratech-labs.com>

File #: LIB-073Q-SAR
 February 20, 2017

- All test results contained in this engineering test report are traceable to National Institute of Standards and Technology (NIST)

processes. All connections are supervised by a watchdog, and disconnection of any of the cables to the measurement server will automatically disarm the robot and disable all program-controlled robot movements. Furthermore, the measurement server is equipped with an expansion port which is reserved for future applications. Please note that this expansion port does not have a standardized pinout, and therefore only devices provided by SPEAG can be connected. Devices from any other supplier could seriously damage the measurement server.

3.3.1.2. *Data Acquisition Electronics*

The data acquisition electronics (DAE4 or DAE3) consist of a highly sensitive electrometer-grade preamplifier with auto-zeroing, a channel and gain-switching multiplexer, a fast 16 bit AD-converter and a command decoder with a control logic unit. Transmission to the measurement server is accomplished through an optical downlink for data and status information, as well as an optical uplink for commands and the clock.

The mechanical probe mounting device includes two different sensor systems for frontal and sideways probe contacts. They are used for mechanical surface detection and probe collision detection.

The input impedance of both the DAE4 as well as of the DAE3 box is 200M Ω ; the inputs are symmetrical and floating. Common mode rejection is above 80 dB.

3.3.1.3. *Dosimetric Probes*

These probes are specially designed and calibrated for use in liquids with high permittivity. They should not be used in air, since the spherical isotropy in air is poor (-2 dB). The dosimetric probes have special calibrations in various liquids at different frequencies.



3.3.1.3.1. *ES3DV3 Isotropic E-Filed Probe*

Construction	Symmetrical design with triangular core Interleaved sensors Built-in shielding against static charges PEEK enclosure material (resistant to organic solvents, e.g., DGBE)
Calibration	Basic Broad Band Calibration in air Conversion Factors (CF) for HSL 900 and HSL 1750 Additional CF for other liquids and frequencies
Frequency	10 MHz to 4 GHz Linearity ± 0.2 dB (30 MHz to 4 GHz)
Directivity	± 0.2 dB in HSL (rotation around probe axis) ± 0.3 dB in tissue material (rotation normal to probe axis)
Dynamic Range	5 μ W/g to > 100 mW/g Linearity: ± 0.2 dB
Dimensions	Overall length: 330 mm (Tip: 20 mm) Tip diameter: 3.9 mm (Body: 12 mm) Distance from probe tip to dipole centers: 2.0 mm

3.3.1.3.2. *EX3DV4 Isotropic E-Filed Probe*

Construction	Symmetrical design with triangular core Built-in shielding against static charges PEEK enclosure material (resistant to organic solvents, e.g., DGBE)
Calibration	Basic Broad Band Calibration in air Conversion Factors (CF) for HSL 900 and HSL 1750 Additional CF for other liquids and frequencies
Frequency	10 MHz to > 6 GHz Linearity: ± 0.2 dB (30 MHz to 6 GHz)
Directivity	± 0.3 dB in HSL (rotation around probe axis) ± 0.5 dB in tissue material (rotation normal to probe axis)
Dynamic Range	10 μ W/g to > 100 mW/g Linearity: ± 0.2 dB (noise: typically < 1 μ W/g)
Dimensions	Overall length: 330 mm (Tip: 20 mm) Tip diameter: 2.5 mm (Body: 12 mm) Typical distance from probe tip to dipole centers: 1 mm

3.3.2. DASY5 SAR SYSTEM block diagram

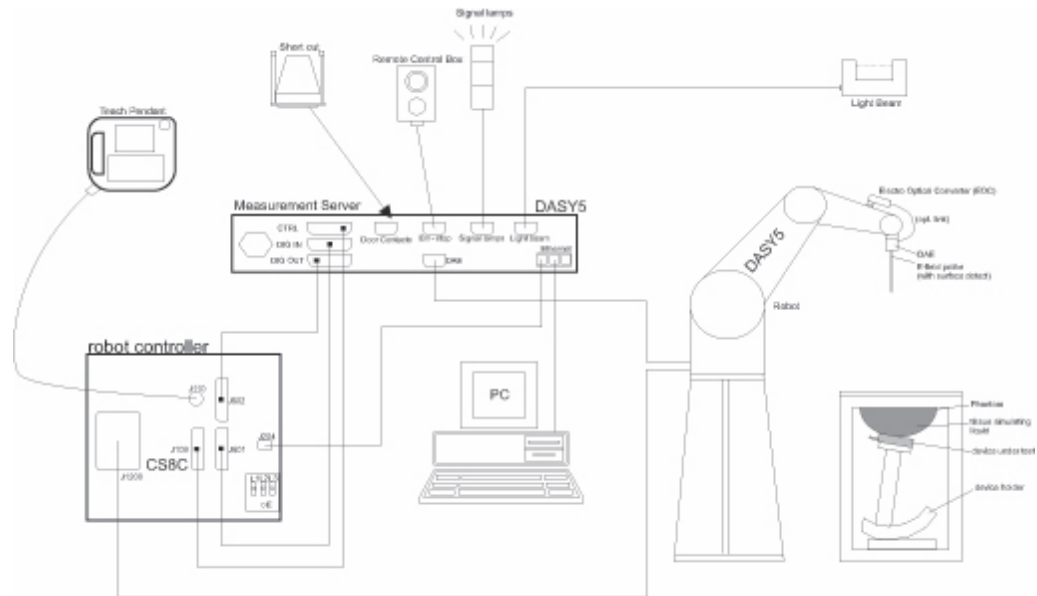

- All test results contained in this engineering test report are traceable to National Institute of Standards and Technology (NIST)

3.4. SAR TEST PHANTOMS

3.4.1. SAM Twin Phantom



For Head mounted devices placed next to the ear, the phantom used in the evaluation of the RF exposure of the user of the wireless device is an IEEE P1528 compliant SAM Twin phantom, shaped like a human head and filled with a mixture simulating the dielectric characteristics of the brain. A left sided head and a right sided head are evaluated to determine the worst case orientation for SAR.

3.4.2. ELI 4.0 Phantom

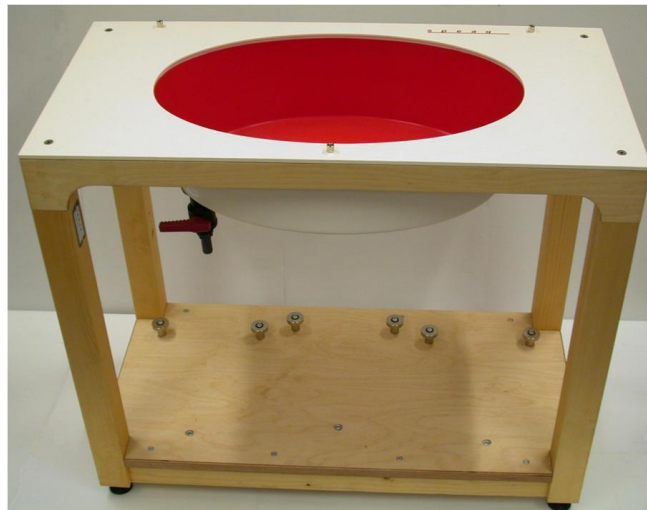

For body mounted and frontal held push-to-talk devices, an IEC 62209-2 compliant Oval Flat Phantom (ELI 4.0) with a base plate thickness of 2mm is used.

ULTRATECH GROUP OF LABS

3000 Bristol Circle, Oakville, Ontario, Canada L6H 6G4
Tel. #: 905-829-1570, Fax. #: 905-829-8050, Email: vic@ultratech-labs.com, Website: <http://www.ultratech-labs.com>

File #: LIB-073Q-SAR
February 20, 2017

- All test results contained in this engineering test report are traceable to National Institute of Standards and Technology (NIST)

EXHIBIT 4. SAR DATA ACQUISITION METHODOLOGY

4.1. SAR MEASUREMENT PROCEDURE

The goal of the measurement process is to scan the phantom over a selected area in order to find the region of highest levels of RF energy and then to obtain a single value for the peak spatial-average of SAR over a volume that would contain one gram (in the shape of a cube) of biological tissue. The test procedure, of course, measures SAR in the simulated tissue.

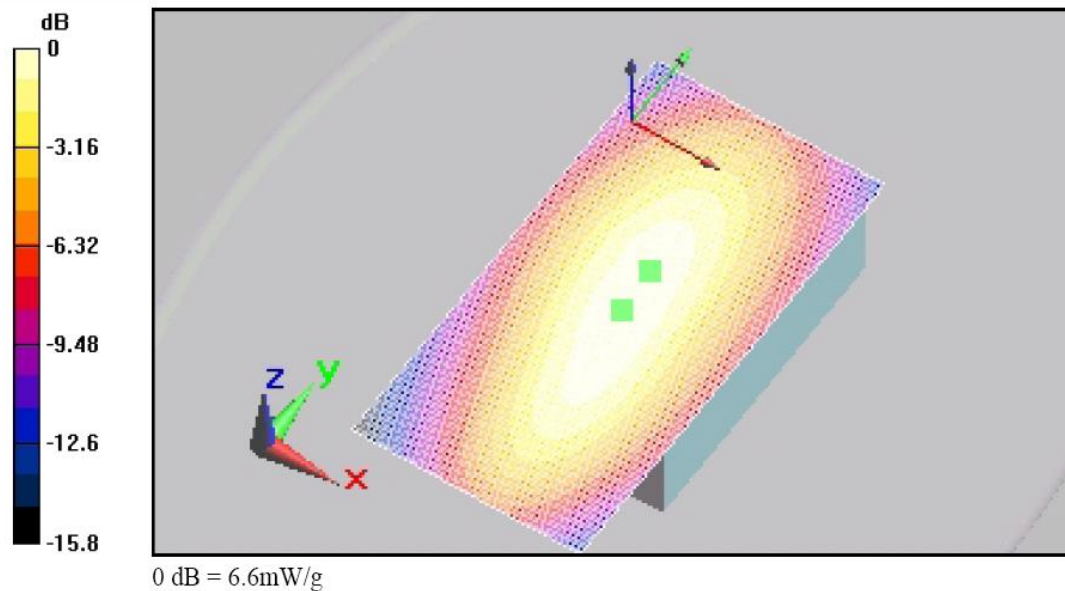

< Area scan >

The software requests the user to move the probe to locations at two extreme corners of a rectangle that encloses the area to be scanned. An arbitrary origin and the spatial resolution for the scan are also specified. Under program control, the scan is performed automatically by the robot-guided probe.

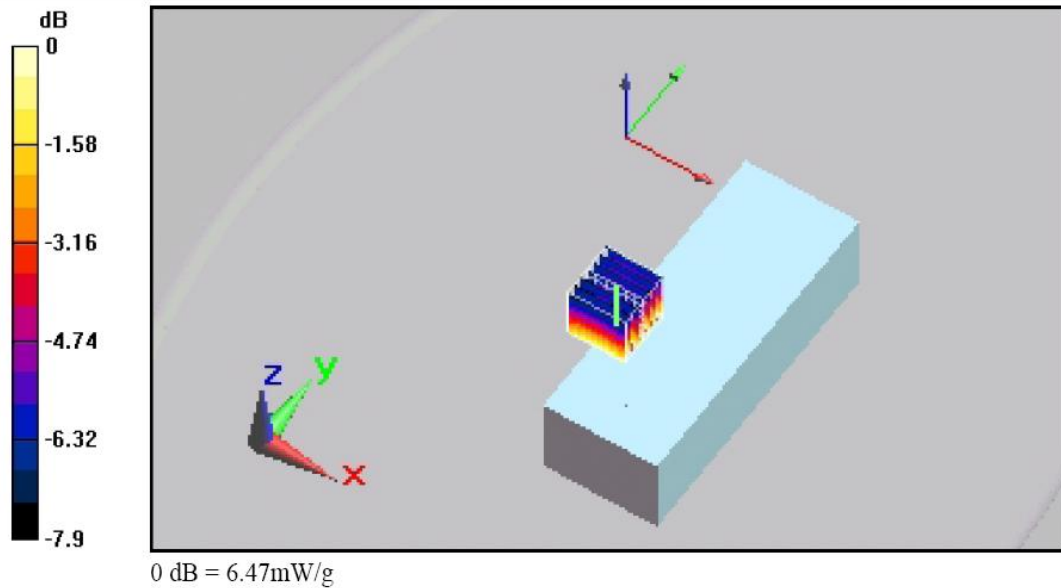

< Zoom Scan >

The DASY5 software includes all numerical procedures necessary to evaluate the spatial peak SAR values.

Based on the Draft: SCC-34, SC-2, WG-2 - Computational Dosimetry, IEEE P1529/D0.0 (Draft Recommended Practice for Determining the Spatial-Peak Specific Absorption Rate (SAR) Associated with the Use of Wireless Handsets - Computational Techniques), a new algorithm has been implemented. The spatial-peak SAR can be computed over any required mass.

The base for the evaluation is a "cube" measurement in a volume of (30mm)³ (7x7x7 points). The measured volume must include the 1 g and 10 g cubes with the highest averaged SAR values. For that purpose, the center of the measured volume is aligned to the interpolated peak SAR value of a previously performed area scan. If the 10g cube or both cubes are not entirely inside the measured volumes, the system issues a warning regarding the evaluated spatial peak values within the postprocessing engine (SEMCAD X). This means that if the measured volume is shifted, higher values might be possible. To get the correct values you can use a finer measurement grid for the area scan. In complicated field distributions, a large grid spacing for the area scan might miss some details and give an incorrectly interpolated peak location.

The entire evaluation of the spatial peak values is performed within the postprocessing engine (SEMCAD X). The system always gives the maximum values for the 1 g and 10 g cubes. The algorithm to find the cube with highest averaged SAR is divided into the following stages:

1. extraction of the measured data (grid and values) from the Zoom Scan
2. calculation of the SAR value at every measurement point based on all stored data (A/D values and measurement parameters)
3. generation of a high-resolution mesh within the measured volume
4. interpolation of all measured values from the measurement grid to the high-resolution grid
5. extrapolation of the entire 3-D field distribution to the phantom surface over the distance from sensor to surface

ULTRATECH GROUP OF LABS

3000 Bristol Circle, Oakville, Ontario, Canada L6H 6G4
Tel. #: 905-829-1570, Fax. #: 905-829-8050, Email: vic@ultratech-labs.com, Website: <http://www.ultratech-labs.com>

File #: LIB-073Q-SAR

February 20, 2017

- All test results contained in this engineering test report are traceable to National Institute of Standards and Technology (NIST)

6. calculation of the averaged SAR within masses of 1 g and 10 g

The significant parts are outlined in more detail within the following sections.

4.1.1. *Interpolation, Extrapolation and Detection of Maxima*

The probe is calibrated at the center of the dipole sensors which is located 1 to 2.7mm away from the probe tip. During measurements, the probe stops shortly above the phantom surface, depending on the probe and the surface detecting system. Both distances are included as parameters in the probe configuration file. The software always knows exactly how far away the measured point is from the surface. As the probe cannot directly measure at the surface, the values between the deepest measured point and the surface must be extrapolated.

In DASY5, the choice of the coordinate system defining the location of the measurement points has no influence on the uncertainty of the interpolation, Maxima Search and extrapolation routines. The interpolation, extrapolation and maximum search routines are all based on the modified Quadratic Shepard's method.

Thereby, the interpolation scheme combines a least-square fitted function method and a weighted average method which are the two basic types of computational interpolation and approximation. The DASY5 routines construct a once-continuously differentiable function that interpolates the measurement values as follows:

- For each measurement point a trivariate (3-D) / bivariate (2-D) quadratic is computed. It interpolates the measurement values at the data point and forms a least-square fit to neighboring measurement values.
- the spatial location of the quadratic with respect to the measurement values is attenuated by an inverse distance weighting. This is performed since the calculated quadratic will fit measurement values at nearby points more accurate than at points located further away.
- After the quadratics are calculated for at all measurement points, the interpolating function is calculated as a weighted average of the quadratics.

There are two control parameters that govern the behavior of the interpolation method . One specifies the number of measurement points to be used in computing the least-square fits for the local quadratics. These measurement points are the ones nearest the input point for which the quadratic is being computed. The second parameter specifies the number of measurement points that will be used in calculating the weights for the quadratics to produce the final function. The input data points used there are the ones nearest the point at which the interpolation is desired. Appropriate defaults are chosen for each of the control parameters

The trivariate quadratics that have been previously computed for the 3-D interpolation and whose input data are at the closest distance from the phantom surface, are used in order to extrapolate the fields to the surface of the phantom.

In order to determine all the field maxima in 2-D (Area Scan) and 3-D (Zoom Scan), the measurement grid is refined by a default factor of 10 and the interpolation function is used to evaluate all field values between corresponding measurement points. Subsequently, a linear search is applied to find all the candidate maxima. In a last step, non physical maxima are removed and only those maxima which are within 2 dB of the global maximum value are retained.

Important: To be processable by the interpolation/extrapolation scheme, the Area Scan requires at least 6 measurement points. The Cube Scan requires at least 10 measurement points to allow an application of these algorithms.

In the Area Scan, the gradient of the interpolation function is evaluated to find all the extrema of the SAR distribution. The uncertainty on the locations of the extrema is less than 1/20 of the grid size. Only local maxima within -2 dB of the global maximum are searched and passed for the Cube Scan measurement.

In the Cube Scan, the interpolation function is used to extrapolate the Peak SAR from the lowest measurement points to the inner phantom surface (the extrapolation distance). The uncertainty increases with the extrapolation distance. To keep the uncertainty within 1% for the 1 g and 10 g cubes, the extrapolation distance should not be larger than 5mm.

4.1.2. Averaging and Determination of Spatial Peak SAR

The interpolated data is used to average the SAR over the 1g and 10g cubes by spatially discretizing the entire measured volume. The resolution of this spatial grid used to calculate the averaged SAR is 1mm or about 42875 interpolated points. The resulting volumes are defined as cubical volumes containing the appropriate tissue parameters that are centered at the location. The location is defined as the center of the incremental volume (voxel).

The spatial-peak SAR must be evaluated in cubical volumes containing a mass that is within 5% of the required mass. The cubical volume centered at each location, as defined above, should be expanded in all directions until the desired value for the mass is reached, with no surface boundaries of the averaging volume extending beyond the outermost surface of the considered region. In addition, the cubical volume should not consist of more than 10% of air. If these conditions are not satisfied then the center of the averaging volume is moved to the next location. Otherwise, the exact size of the final sampling cube is found using an inverse polynomial approximation algorithm, leading to results with improved accuracy. If one boundary of the averaging volume reaches the boundary of the measured volume during its expansion, it will not be evaluated at all. Reference is kept of all locations used and those not used for averaging the SAR. All average SAR values are finally assigned to the centered location in each valid averaging volume.

All locations included in an averaging volume are marked to indicate that they have been used at least once. If a location has been marked as used, but has never been assigned to the center of a cube, the highest averaged SAR value of all other cubical volumes which have used this location for averaging, is assigned to this location. Only those locations that are not part of any valid averaging volume should be marked as unused. For the case of an unused location, a new averaging volume must be constructed which will have the unused location centered at one surface of the cube. The remaining five surfaces are expanded evenly in all directions until the required mass is enclosed, regardless of the amount of included air. Of the six possible cubes with one surface centered on the unused location, the smallest cube is used, which still contains the required mass.

If the final cube containing the highest averaged SAR touches the surface of the measured volume, an appropriate warning is issued within the postprocessing engine.

4.1.3. Evaluation Errors

4.1.3.1. Cube shape

The mentioned procedures search for the maximum averaged 1g and 10g volumes of cubical shape according to the ANSI and ICNIRP standard. A density of 1000 kg/m³ is used to represent the head tissue density and not the tissue simulating liquid density.

4.1.3.2. Extrapolation

For the extrapolation the distance must be specified in the Area Scan and Zoom Scan Jobs. The distance is defined as the distance between the probe sensor center and the phantom surface. The recommended distance is 4-5 mm.

4.1.3.3. Boundary effects

The dosimetric probes are calibrated in a gradient field with energy flow and decay in direction of the probe axis. During calibration the probe tip is completely surrounded by the simulating solution. If the probe is used in the immediate vicinity of a media boundary, the field in the probe is altered due to interaction with the field in the boundary and the probe sensitivity changes. The influence of the boundary effect depends on the probe construction, the media parameters and the probe orientation with respect to the boundary. It disappears at a distance of 1mm (E1D-probe) to 5mm (ET3D-probes) between the probe tip and the boundary. The boundary effect must be considered in the extrapolation to the surface.

EXHIBIT 5. MEASUREMENTS, EXAMINATIONS & TEST DATA

5.1. TEST CONFIGURATIONS

5.1.1. Wifi 802.11 a/b/g/n 2450 MHz

D.U.T. Information		Condition	
Product Name	Librestream Technologies Inc	Robot Type	6 Axis
Model Number	5000HD	Scan Type	SAR – Area/Zoom/Att. Vs Depth
Serial Number	LSTW2001T3	Measured Field	E
Frequency Band [MHz]	802.11 abgn 2.45/5 GHz	Phantom Type	2 _{mm} base Flat Phantom
Frequency Tested [MHz]	2412, 2437, 2462 MHz 5180, 5220, 5240, 5260, 5300, 5320, 5500, 5540, 5580, 5620, 5660, 5765, 5805	Phantom Position	Waist
Maximum Conducted Power	18/16 dBm ± 1.5dB ⁴	Room Temperature [°C]	24.0 ± 1
Antenna Type	Antenna 1 - Laird Technologies D-Puck EMM00119-RE1PCB mounted Antenna 2 – Antenova SR42W001 NFC Antenna – PCB Trace	Room Humidity [%]	40 ± 10
Modulation	BPSK, QPSK, QAM, OFDM	Tissue Temperature [°C]	21.4 ± 1
Worst Case Duty Cycle	100 %		
Duty Cycle Tested	100%		
Source(or Usage)-Based Time-Average Factor	1		

Type of Tissue	Muscle
Test Frequency [MHz]	2450
Target Conductivity [S/m]	1.95
Measured Conductivity [S/m]	1.92 (-1.7 %)
Target Dielectric Constant	52.7
Measured Dielectric Constant	51.9 (-1.4 %)
Penetration Depth (Plane Wave Excitation) [mm]	20.1
Probe Model Number	EX3DV4
Probe Serial Number	3673
Probe Orientation	Isotropic
Probe Sensor Offset [mm]	1
Probe Tip Diameter [mm]	2.5
Conversion Factor (γ)	7.26 (+/- 12.0%)

⁴ Tolerance specified is obtained from the manufacturer’s tune-up procedures

ULTRATECH GROUP OF LABS

3000 Bristol Circle, Oakville, Ontario, Canada L6H 6G4
 Tel. #: 905-829-1570, Fax. #: 905-829-8050, Email: vic@ultratech-labs.com, Website: <http://www.ultratech-labs.com>

File #: LIB-073Q-SAR

February 20, 2017

- All test results contained in this engineering test report are traceable to National Institute of Standards and Technology (NIST)

5.1.2. Wifi 802.11 a/b/g/n 5200-5825 MHz

D.U.T. Information		Condition	
Product Name	Librestream Technologies Inc	Robot Type	6 Axis
Model Number	5000HD	Scan Type	SAR – Area/Zoom/Att. Vs Depth
Serial Number	LSTW2001T3	Measured Field	E
Frequency Band [MHz]	802.11 abgn 2.45/5 GHz	Phantom Type	2mm base Flat Phantom
Frequency Tested [MHz]	2412, 2437, 2462 MHz 5180, 5220, 5240, 5260, 5300, 5320, 5500, 5540, 5580, 5620, 5660, 5765, 5805	Phantom Position	Waist
Maximum Conducted Power	18/16 dBm ± 1.5dB ⁵	Room Temperature [°C]	24.0 ± 1
Antenna Type	Antenna 1 - Laird Technologies D-Puck EMM00119-RE1PCB mounted Antenna 2 – Antenova SR42W001 NFC Antenna – PCB Trace	Room Humidity [%]	40 ± 10
Modulation	BPSK, QPSK, QAM, OFDM	Tissue Temperature [°C]	21.4 ± 1
Worst Case Duty Cycle	100 %		
Duty Cycle Tested	100%		
Source(or Usage)-Based Time-Average Factor	1		

Type of Tissue	Muscle
Test Frequency [MHz]	5500
Target Conductivity [S/m]	5.65
Measured Conductivity [S/m]	6.0 (6.1 %)
Target Dielectric Constant	48.6
Measured Dielectric Constant	46.3 (-4.7 %)
Penetration Depth (Plane Wave Excitation) [mm]	6.2
Probe Model Number	EX3DV4
Probe Serial Number	3673
Probe Orientation	Isotropic
Probe Sensor Offset [mm]	1
Probe Tip Diameter [mm]	2.5
Conversion Factor (γ)	5200MHz - 4.66 (+/- 12.0%) 5300MHz - 4.76 (+/- 12.0%) 5500MHz - 4.96 (+/- 12.0%) 5600MHz – 5.07 (+/- 12.0%) 5800MHz – 5.27 (+/- 12.0%)

⁵ Tolerance specified is obtained from the manufacturer’s tune-up procedures

ULTRATECH GROUP OF LABS

3000 Bristol Circle, Oakville, Ontario, Canada L6H 6G4
 Tel. #: 905-829-1570, Fax. #: 905-829-8050, Email: vic@ultratech-labs.com, Website: <http://www.ultratech-labs.com>

File #: LIB-073Q-SAR

February 20, 2017

- All test results contained in this engineering test report are traceable to National Institute of Standards and Technology (NIST)

5.2. GENERAL TEST SETUP

5.2.1. Equipment Configuration

Power and signal distribution, grounding, interconnecting cabling and physical placement of equipment of a test system shall simulate the typical application and usage in so far as is practicable, and shall be in accordance with the relevant product specifications of the manufacturer.

The configuration that tends to maximize the D.U.T's emission or minimize its immunity is not usually intuitively obvious and in most instances selection will involve some trial and error testing. For example, interface cables may be moved or equipment re-orientated during initial stages of testing and the effects on the results observed.

Only configurations within the range of positions likely to occur in normal use need to be considered.

The configuration selected shall be fully detailed and documented in the test report, together with the justification for selecting that particular configuration.

5.2.2. Exercising Equipment

The exercising equipment and other auxiliary equipment shall be sufficiently decoupled from the D.U.T. so that the performance of such equipment does not significantly influence the test results.

5.3. PHOTOGRAPHS OF TISSUE DEPTH

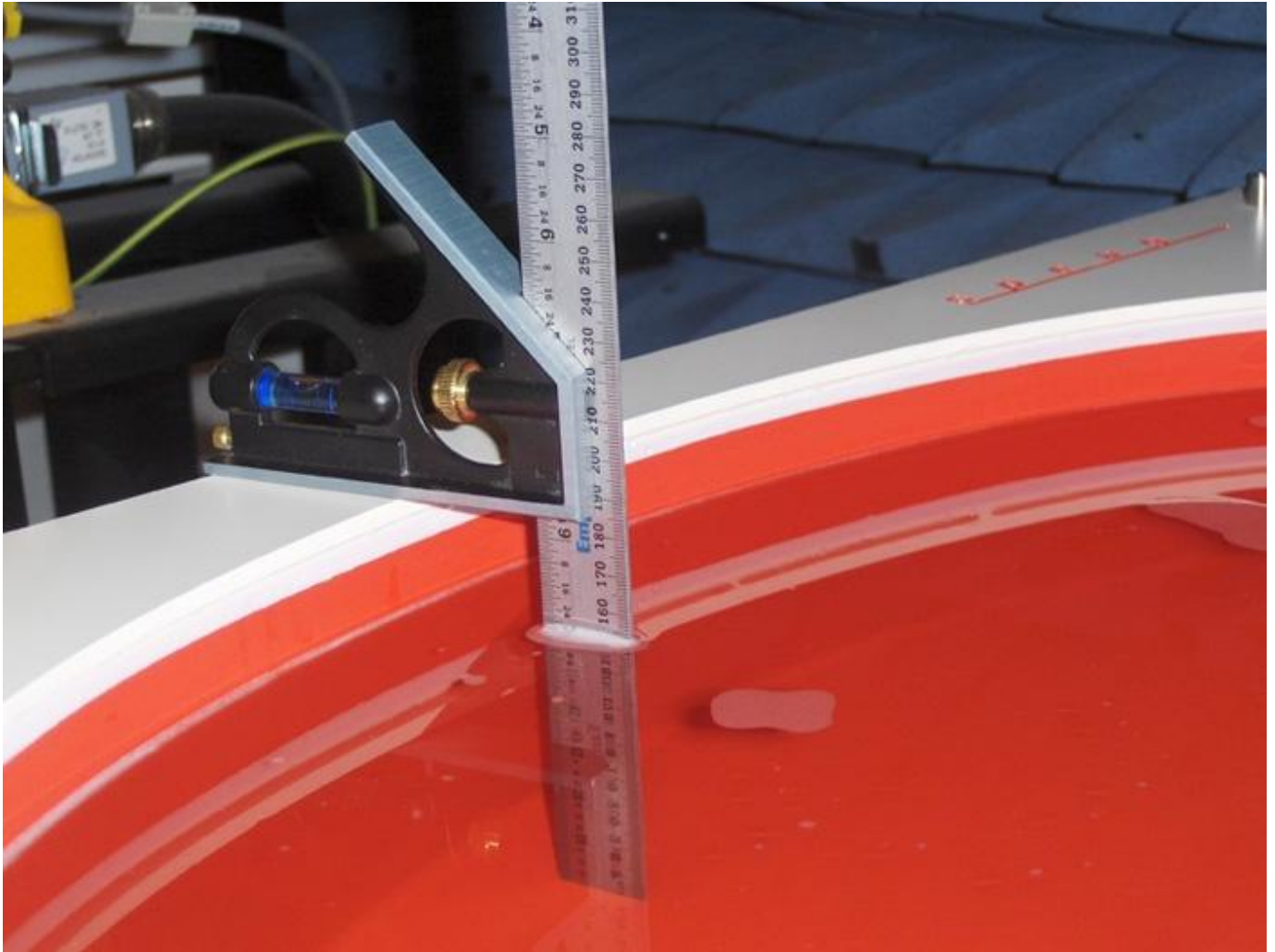

< Phantom filled with body tissue liquid: liquid level = 150mm ± 5mm >

ULTRATECH GROUP OF LABS

3000 Bristol Circle, Oakville, Ontario, Canada L6H 6G4
Tel. #: 905-829-1570, Fax. #: 905-829-8050, Email: vic@ultratech-labs.com, Website: <http://www.ultratech-labs.com>

File #: LIB-073Q-SAR
February 20, 2017

- All test results contained in this engineering test report are traceable to National Institute of Standards and Technology (NIST)

5.4. PHOTOGRAPHS OF D.U.T. POSITION

5.4.1. Body Configuration for EUT Top Side Exposure

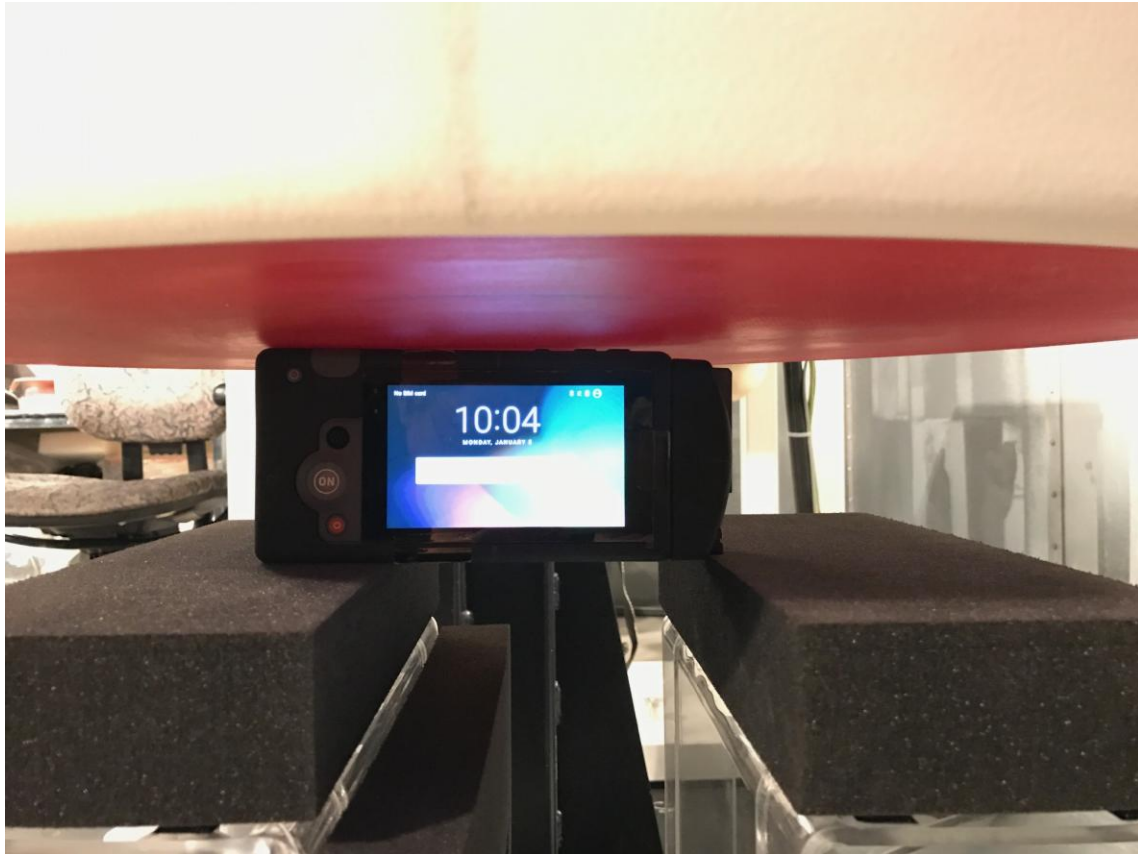

<Top Side Exposure >

Remark: Distance between Top side of the EUT and the phantom = 0 mm

ULTRATECH GROUP OF LABS

3000 Bristol Circle, Oakville, Ontario, Canada L6H 6G4
Tel. #: 905-829-1570, Fax. #: 905-829-8050, Email: vic@ultratech-labs.com, Website: <http://www.ultratech-labs.com>

File #: LIB-073Q-SAR

February 20, 2017

- All test results contained in this engineering test report are traceable to National Institute of Standards and Technology (NIST)

5.4.2. *Body Configuration for Back Side Exposure*



< Back Side Exposure >

Remark: Distance between Back side of the EUT and the phantom = 0 mm

ULTRATECH GROUP OF LABS

3000 Bristol Circle, Oakville, Ontario, Canada L6H 6G4
Tel. #: 905-829-1570, Fax. #: 905-829-8050, Email: vic@ultratech-labs.com, Website: <http://www.ultratech-labs.com>

File #: LIB-073Q-SAR

February 20, 2017

- All test results contained in this engineering test report are traceable to National Institute of Standards and Technology (NIST)

5.4.3. *Body Configuration for Front Side Exposure*



<Front Side Exposure >

Remark: Distance between Front Side of the EUT and the phantom = 0 mm

ULTRATECH GROUP OF LABS

3000 Bristol Circle, Oakville, Ontario, Canada L6H 6G4
Tel. #: 905-829-1570, Fax. #: 905-829-8050, Email: vic@ultratech-labs.com, Website: <http://www.ultratech-labs.com>

File #: LIB-073Q-SAR

February 20, 2017

- All test results contained in this engineering test report are traceable to National Institute of Standards and Technology (NIST)

5.4.4. EUT Alignment with Phantom and Probe coordinates for maximum SAR Top Side Exposure

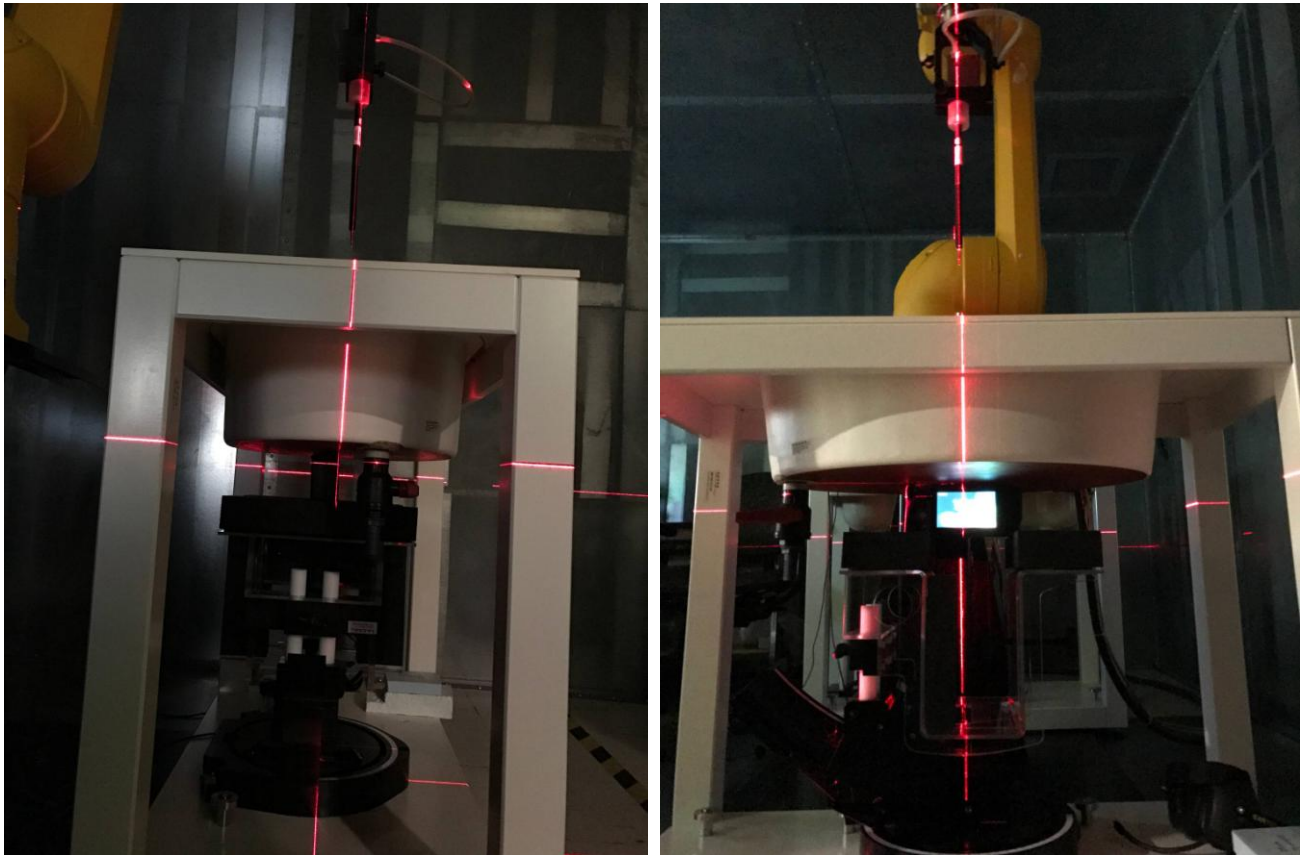

<Top Side Exposure >

Remark: Distance between Top side of the EUT and the phantom = 0 mm

ULTRATECH GROUP OF LABS

3000 Bristol Circle, Oakville, Ontario, Canada L6H 6G4
Tel. #: 905-829-1570, Fax. #: 905-829-8050, Email: vic@ultratech-labs.com, Website: <http://www.ultratech-labs.com>

File #: LIB-073Q-SAR
February 20, 2017

- All test results contained in this engineering test report are traceable to National Institute of Standards and Technology (NIST)

EXHIBIT 6. SAR MEASUREMENT SYSTEM VERIFICATION

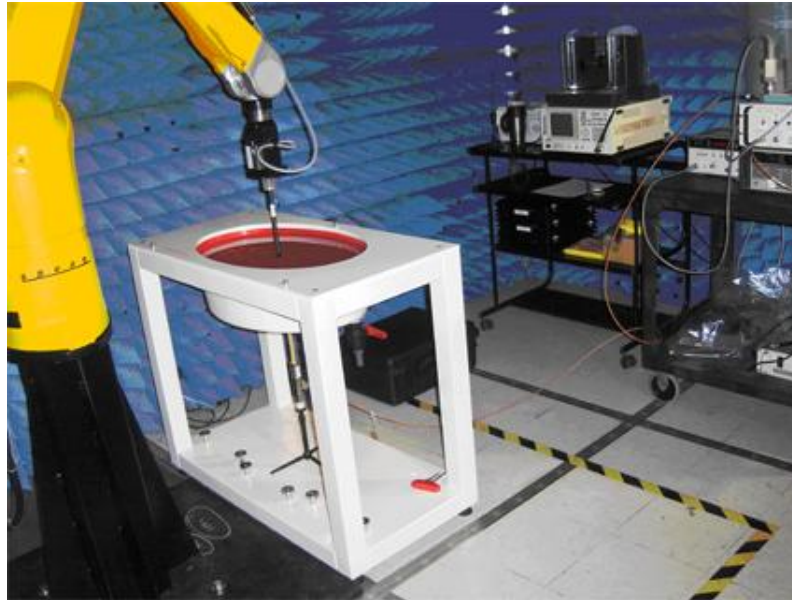

6.1. STANDARD SOURCE

A half-wave dipole is positioned below the bottom of the phantom and centered with its axis parallel to the longest side of the phantom. The distance between the liquid filled phantom bottom surface and the center of the dipole axis, s , is chosen as specified IEEE 1528 at the specific test frequency (i.e. 15 mm at 835 MHz). A low loss and low dielectric constant spacer is used to establish the correct distance between the top surface of the dipole and the bottom surface of the phantom.

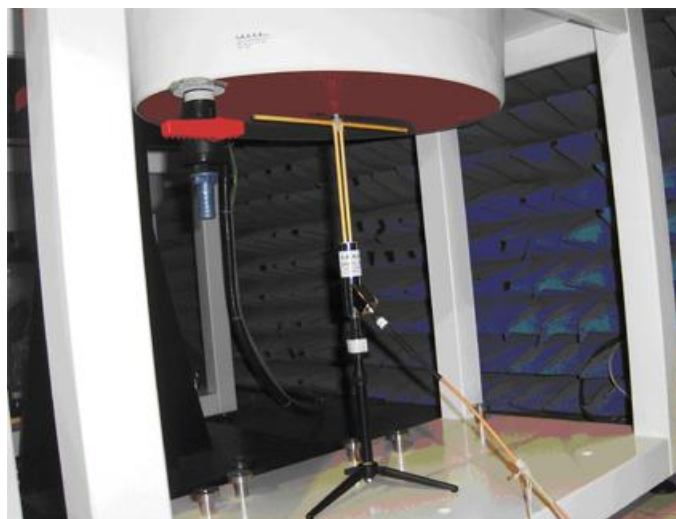

ULTRATECH GROUP OF LABS

3000 Bristol Circle, Oakville, Ontario, Canada L6H 6G4
Tel. #: 905-829-1570, Fax. #: 905-829-8050, Email: vic@ultratech-labs.com, Website: <http://www.ultratech-labs.com>

File #: LIB-073Q-SAR
February 20, 2017

- All test results contained in this engineering test report are traceable to National Institute of Standards and Technology (NIST)

6.2. STANDARD SOURCE INPUT POWER MEASUREMENT

The system validation is performed as shown below or in Figure 7.1 in IEEE 1528.

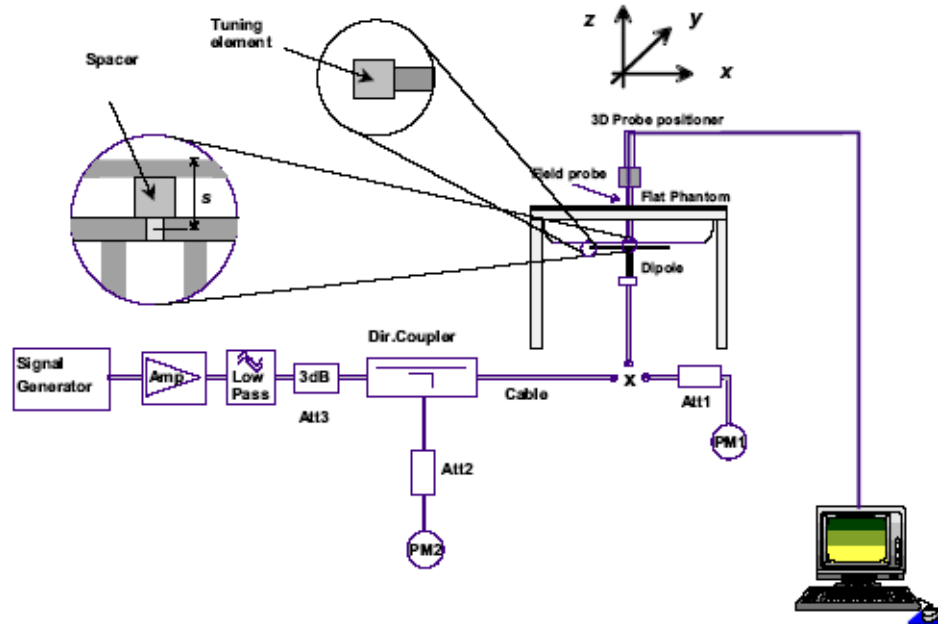

First the power meter PM1 (including attenuator Att1) is connected to the cable to measure the forward power at the location of the dipole connector (X). The signal generator is adjusted for the desired forward power at the dipole connector (taking into account the attenuation of Att1) as read by power meter PM2. After connecting the cable to the dipole, the signal generator is readjusted for the same reading at power meter PM2. If the signal generator does not allow adjustment in 0.01dB steps, the remaining difference at PM2 must be taken into consideration. PM3 records the reflected power from the dipole to ensure that the value is not changed from the previous value. The reflected power was verified to be at least 20dB below the forward power.

6.3. SYSTEM VALIDATION PROCEDURE

A complete 1g-averaged SAR measurement is performed. The measured 1g-averaged SAR value is normalized to a forward power of 1W to a half-wave dipole and compared with the reference SAR value for the reference dipole and flat phantom shown in columns 2 and 3 of Table 7.1 in IEEE 1528.

6.4. VERIFICATION RESULTS

6.4.1. Reference Dipole SAR measurements

	Frequency (MHz)	SAR1g			SAR10g		
		Reference (mw/g)	Measured (mw/g)	Delta %	Reference (mw/g)	Measured (mw/g)	Delta %
Body	2450	50.70	50.00	1.38%	24.10	23.44	2.74%
	5200	74.10	75.10	-1.35%	20.80	21.20	-1.92%
	5400	76.70	73.50	4.17%	21.40	20.70	3.27%
	5600	76.10	75.40	0.92%	21.20	21.20	0.00%
	5800	75.50	76.90	-1.85%	21.00	21.50	-2.38%

ULTRATECH GROUP OF LABS

3000 Bristol Circle, Oakville, Ontario, Canada L6H 6G4
Tel. #: 905-829-1570, Fax. #: 905-829-8050, Email: vic@ultratech-labs.com, Website: <http://www.ultratech-labs.com>

File #: LIB-073Q-SAR

February 20, 2017

- All test results contained in this engineering test report are traceable to National Institute of Standards and Technology (NIST)

6.4.2. Verification at 2450 MHz

Test Laboratory: Ultratech Group of Labs

File Name: [System Verification - D2450MHz Body.da52:0](#)

DUT: D2450V2; Type: SA AAD 245BB; Serial: 821

Communication System: UID 0, CW; Frequency: 2450 MHz; Duty Cycle: 1:1

Medium parameters used: $f = 2450$ MHz; $\sigma = 1.918$ S/m; $\epsilon_r = 51.938$; $\rho = 1000$ kg/m³; Phantom section: Flat Section; Measurement Standard: DASY5 (IEEE/IEC/ANSI C63.19-2007)

DASY Configuration:

- Probe: EX3DV4 - SN3673; ConvF(7.36, 7.36, 7.36); Calibrated: 8/29/2016;
- Sensor-Surface: 4mm (Mechanical Surface Detection), Sensor-Surface: 2mm (Mechanical Surface Detection)
- Electronics: DAE4 Sn874; Calibrated: 8/22/2016
- Phantom: ELI 4.0; Type: QD OVA 001 BB; Serial: 1057
- DASY52 52.8.8(1222); SEMCAD X 14.6.10(7331)

System Verification at 2.45GHz_Body/d=10mm, Pin=250mW, dist=2.0mm (EX-Probe)/Zoom Scan (7x7x7) (7x7x7)/Cube 0: Measurement grid: dx=5mm, dy=5mm, dz=5mm

Reference Value = 95.78 V/m; Power Drift = -0.15 dB

Peak SAR (extrapolated) = 25.0 W/kg

SAR(1 g) = 12.5 W/kg; SAR(10 g) = 5.86 W/kg

Maximum value of SAR (measured) = 14.2 W/kg

System Verification at 2.45GHz_Body/d=10mm, Pin=250mW, dist=2.0mm (EX-Probe)/Area Scan (61x81x1): Interpolated grid: dx=1.500 mm, dy=1.500 mm

Maximum value of SAR (interpolated) = 19.8 W/kg

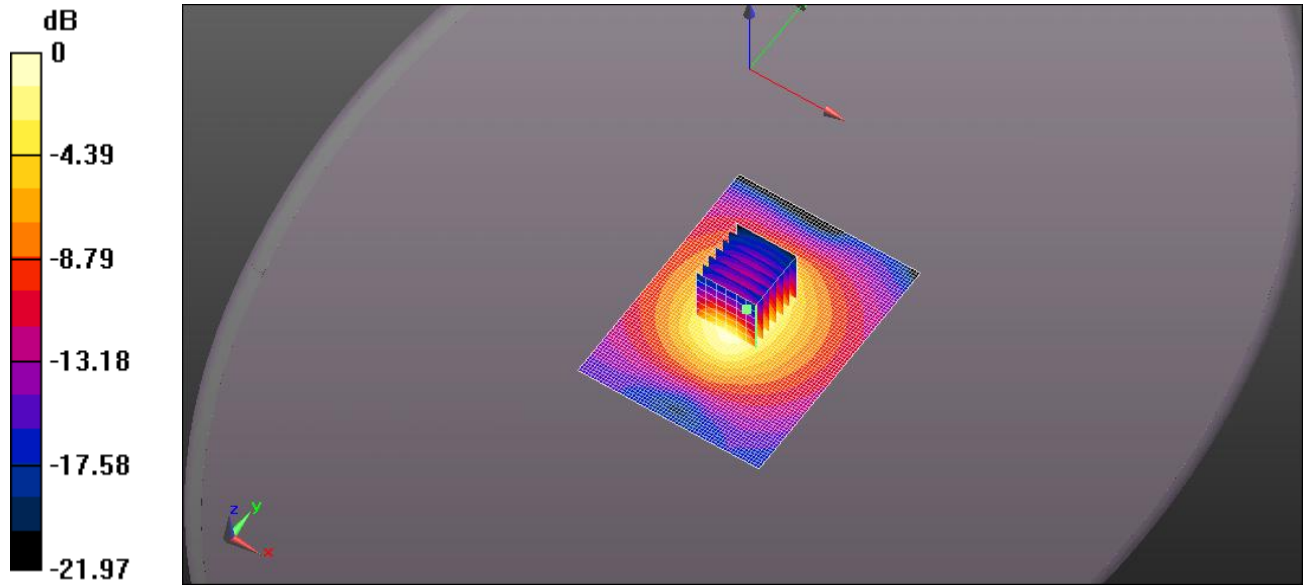

0 dB = 14.2 W/kg = 11.53 dBW/kg

ULTRATECH GROUP OF LABS

3000 Bristol Circle, Oakville, Ontario, Canada L6H 6G4
Tel. #: 905-829-1570, Fax. #: 905-829-8050, Email: vic@ultratech-labs.com, Website: <http://www.ultratech-labs.com>

File #: LIB-073Q-SAR

February 20, 2017

- All test results contained in this engineering test report are traceable to National Institute of Standards and Technology (NIST)

6.4.3. Verification at 5200 MHz

Test Laboratory: Ultratech Group of Labs

File Name: [System Verification - D5200MHz Body.da52:0](#)

DUT: Dipole D5GHzV2; Type: D5GHzV2; Serial: D5GHzV2 - SN:1069

Communication System: UID 0, CW (0); Frequency: 5200 MHz; Duty Cycle: 1:1

Medium parameters used: $f = 5200$ MHz; $\sigma = 5.522$ S/m; $\epsilon_r = 47.132$; $\rho = 1000$ kg/m³; Phantom section: Flat Section; Measurement Standard: DASYS (IEEE/IEC/ANSI C63.19-2007)

DASY Configuration:

- Probe: EX3DV4 - SN3673; ConvF(4.55, 4.55, 4.55); Calibrated: 8/29/2016;
- Sensor-Surface: 1.4mm (Mechanical Surface Detection)
- Electronics: DAE4 Sn874; Calibrated: 8/22/2016
- Phantom: ELI 4.0; Type: QD OVA 001 BB; Serial: 1057
- DASYS2 52.8.8(1222); SEMCAD X 14.6.10(7331)

System Verification at 5.2GHz_Body/d=10mm, Pin=100mW (EX-Probe)/Zoom Scan (8x8x7) (9x9x8)/Cube 0: Measurement grid: dx=4mm, dy=4mm, dz=3mm

Reference Value = 46.04 V/m; Power Drift = -0.15 dB

Peak SAR (extrapolated) = 29.4 W/kg

SAR(1 g) = 7.51 W/kg; SAR(10 g) = 2.12 W/kg (SAR corrected for target medium)

Maximum value of SAR (measured) = 18.2 W/kg

System Verification at 5.2GHz_Body/d=10mm, Pin=100mW (EX-Probe)/Area Scan (41x61x1): Interpolated grid: dx=1.500 mm, dy=1.500 mm

Maximum value of SAR (interpolated) = 13.3 W/kg

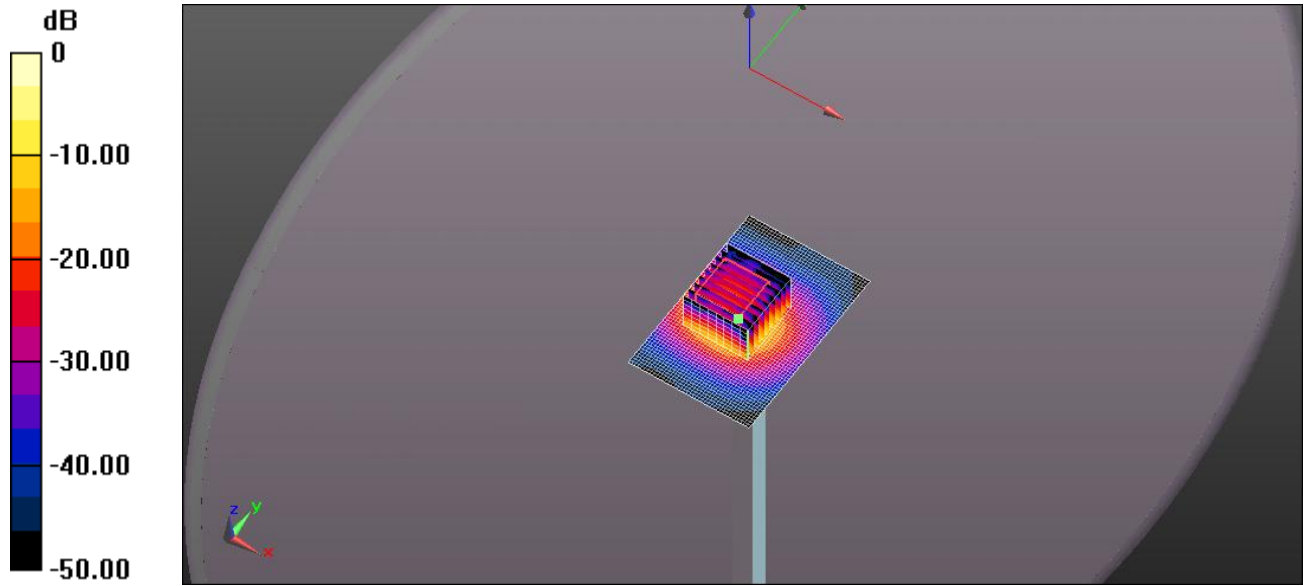

0 dB = 18.2 W/kg = 12.61 dBW/kg

ULTRATECH GROUP OF LABS

3000 Bristol Circle, Oakville, Ontario, Canada L6H 6G4
Tel. #: 905-829-1570, Fax. #: 905-829-8050, Email: vic@ultratech-labs.com, Website: <http://www.ultratech-labs.com>

File #: LIB-073Q-SAR

February 20, 2017

- All test results contained in this engineering test report are traceable to National Institute of Standards and Technology (NIST)

6.4.4. Verification at 5400 MHz

Test Laboratory: Ultratech Group of Labs

File Name: [System Verification - D5400MHz Body.da52:0](#)

DUT: Dipole D5GHzV2; Type: D5GHzV2; Serial: D5GHzV2 - SN:1069

Communication System: UID 0, CW (0); Frequency: 5400 MHz; Duty Cycle: 1:1

Medium parameters used: $f = 5400$ MHz; $\sigma = 5.828$ S/m; $\epsilon_r = 46.531$; $\rho = 1000$ kg/m³; Phantom section: Flat Section; Measurement Standard: DASYS (IEEE/IEC/ANSI C63.19-2007)

DASY Configuration:

- Probe: EX3DV4 - SN3673; ConvF(4.26, 4.26, 4.26); Calibrated: 8/29/2016;
- Sensor-Surface: 1.4mm (Mechanical Surface Detection)
- Electronics: DAE4 Sn874; Calibrated: 8/22/2016
- Phantom: ELI 4.0; Type: QD OVA 001 BB; Serial: 1057
- DASYS 52.8.8(1222); SEMCAD X 14.6.10(7331)

System Verification at 5.2GHz_Body/d=10mm, Pin=100mW (EX-Probe)/Zoom Scan (8x8x7) (9x9x8)/Cube 0: Measurement grid: dx=4mm, dy=4mm, dz=3mm

Reference Value = 41.81 V/m; Power Drift = 0.26 dB

Peak SAR (extrapolated) = 29.4 W/kg

SAR(1 g) = 7.35 W/kg; SAR(10 g) = 2.07 W/kg (SAR corrected for target medium)

Maximum value of SAR (measured) = 18.8 W/kg

System Verification at 5.2GHz_Body/d=10mm, Pin=100mW (EX-Probe)/Area Scan (41x61x1): Interpolated grid: dx=1.500 mm, dy=1.500 mm

Maximum value of SAR (interpolated) = 14.1 W/kg

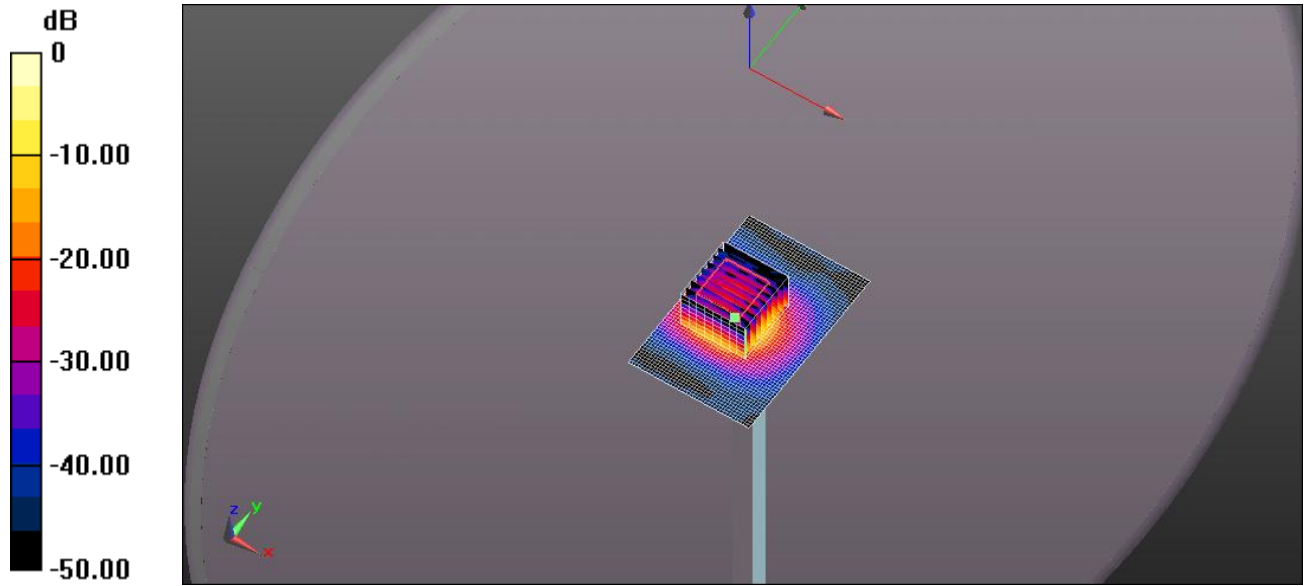

0 dB = 18.8 W/kg = 12.74 dBW/kg

ULTRATECH GROUP OF LABS

3000 Bristol Circle, Oakville, Ontario, Canada L6H 6G4
Tel. #: 905-829-1570, Fax. #: 905-829-8050, Email: vic@ultratech-labs.com, Website: <http://www.ultratech-labs.com>

File #: LIB-073Q-SAR

February 20, 2017

- All test results contained in this engineering test report are traceable to National Institute of Standards and Technology (NIST)

6.4.5. Verification at 5600 MHz

Test Laboratory: Ultratech Group of Labs

File Name: [System Verification - D5600MHz Body.da52:0](#)

DUT: Dipole D5GHzV2; Type: D5GHzV2; Serial: D5GHzV2 - SN:1069

Communication System: UID 0, CW (0); Frequency: 5600 MHz; Duty Cycle: 1:1

Medium parameters used: $f = 5600$ MHz; $\sigma = 6.159$ S/m; $\epsilon_r = 46.005$; $\rho = 1000$ kg/m³; Phantom section: Flat Section; Measurement Standard: DASYS (IEEE/IEC/ANSI C63.19-2007)

DASY Configuration:

- Probe: EX3DV4 - SN3673; ConvF(4.08, 4.08, 4.08); Calibrated: 8/29/2016;
- Sensor-Surface: 1.4mm (Mechanical Surface Detection)
- Electronics: DAE4 Sn874; Calibrated: 8/22/2016
- Phantom: ELI 4.0; Type: QD OVA 001 BB; Serial: 1057
- DASYS 52.8.8(1222); SEMCAD X 14.6.10(7331)

System Verification at 5.2GHz_Body/d=10mm, Pin=100mW (EX-Probe)/Zoom Scan (8x8x7) (9x9x8)/Cube 0: Measurement grid: dx=4mm, dy=4mm, dz=3mm

Reference Value = 41.32 V/m; Power Drift = -0.06 dB

Peak SAR (extrapolated) = 31.9 W/kg

SAR(1 g) = 7.54 W/kg; SAR(10 g) = 2.12 W/kg (SAR corrected for target medium)

Maximum value of SAR (measured) = 19.7 W/kg

System Verification at 5.2GHz_Body/d=10mm, Pin=100mW (EX-Probe)/Area Scan (41x61x1): Interpolated grid: dx=1.500 mm, dy=1.500 mm

Maximum value of SAR (interpolated) = 14.9 W/kg

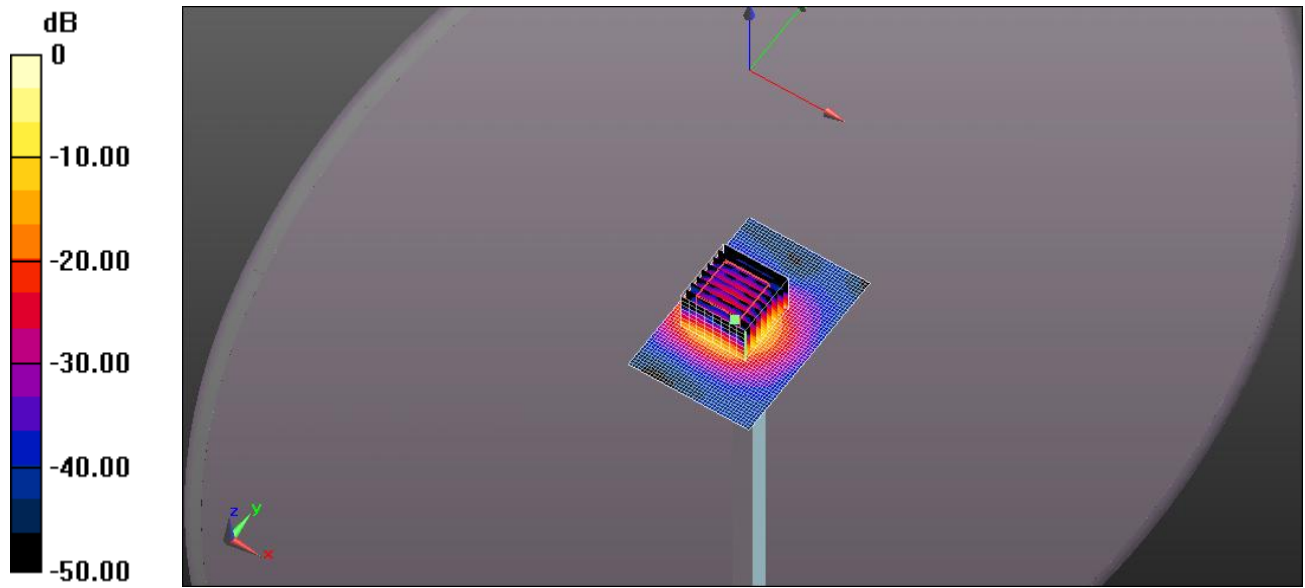

0 dB = 19.7 W/kg = 12.95 dBW/kg

ULTRATECH GROUP OF LABS

3000 Bristol Circle, Oakville, Ontario, Canada L6H 6G4
Tel. #: 905-829-1570, Fax. #: 905-829-8050, Email: vic@ultratech-labs.com, Website: <http://www.ultratech-labs.com>

File #: LIB-073Q-SAR

February 20, 2017

- All test results contained in this engineering test report are traceable to National Institute of Standards and Technology (NIST)

6.4.6. Verification at 5800 MHz

Test Laboratory: Ultratech Group of Labs

File Name: [System Verification - D5800MHz Body.da52:0](#)

DUT: Dipole D5GHzV2; Type: D5GHzV2; Serial: D5GHzV2 - SN:1069

Communication System: UID 0, CW (0); Frequency: 5800 MHz; Duty Cycle: 1:1

Medium parameters used: $f = 5800$ MHz; $\sigma = 6.471$ S/m; $\epsilon_r = 45.389$; $\rho = 1000$ kg/m³; Phantom section: Flat Section; Measurement Standard: DASYS (IEEE/IEC/ANSI C63.19-2007)

DASY Configuration:

- Probe: EX3DV4 - SN3673; ConvF(3.94, 3.94, 3.94); Calibrated: 8/29/2016;
- Sensor-Surface: 1.4mm (Mechanical Surface Detection)
- Electronics: DAE4 Sn874; Calibrated: 8/22/2016
- Phantom: ELI 4.0; Type: QD OVA 001 BB; Serial: 1057
- DASYS 52.8.8(1222); SEMCAD X 14.6.10(7331)

System Verification at 5.2GHz_Body/d=10mm, Pin=100mW (EX-Probe)/Zoom Scan (8x8x7) (9x9x8)/Cube 0: Measurement grid: dx=4mm, dy=4mm, dz=3mm

Reference Value = 41.37 V/m; Power Drift = 0.09 dB

Peak SAR (extrapolated) = 34.1 W/kg

SAR(1 g) = 7.69 W/kg; SAR(10 g) = 2.15 W/kg (SAR corrected for target medium)

Maximum value of SAR (measured) = 20.7 W/kg

System Verification at 5.2GHz_Body/d=10mm, Pin=100mW (EX-Probe)/Area Scan (41x61x1): Interpolated grid: dx=1.500 mm, dy=1.500 mm

Maximum value of SAR (interpolated) = 14.8 W/kg

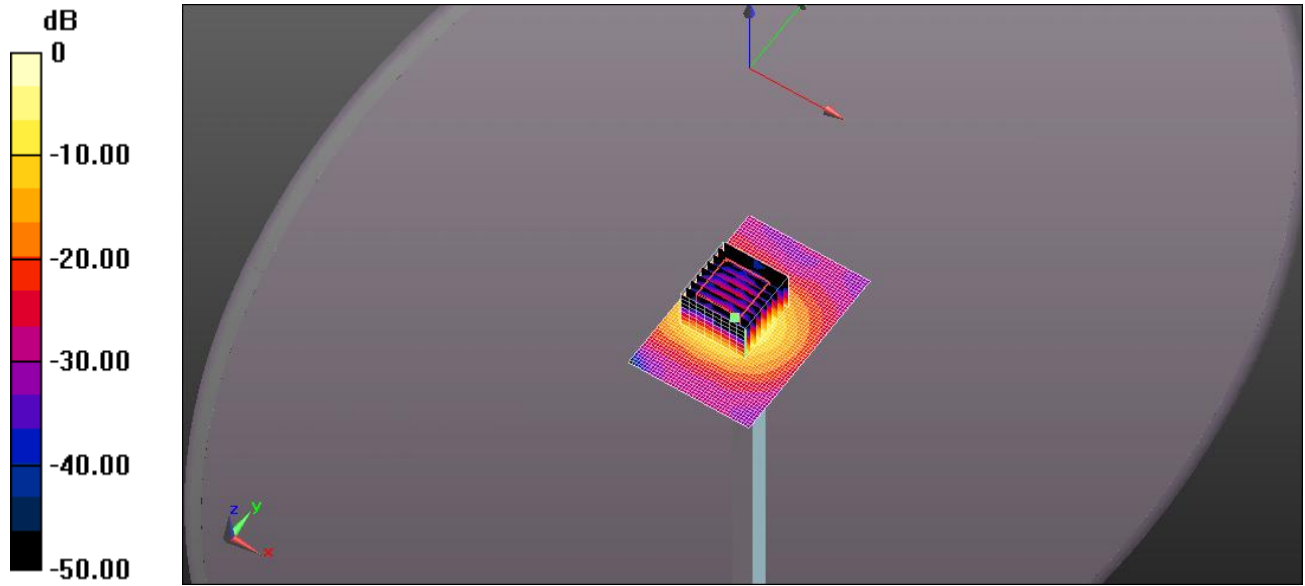

0 dB = 20.7 W/kg = 13.15 dBW/kg

ULTRATECH GROUP OF LABS

3000 Bristol Circle, Oakville, Ontario, Canada L6H 6G4
Tel. #: 905-829-1570, Fax. #: 905-829-8050, Email: vic@ultratech-labs.com, Website: <http://www.ultratech-labs.com>

File #: LIB-073Q-SAR

February 20, 2017

- All test results contained in this engineering test report are traceable to National Institute of Standards and Technology (NIST)

EXHIBIT 7. D.U.T. POWER MEASUREMENT

Whenever possible, a conducted power measurement is performed. To accomplish this, we utilize a fully charged battery, a calibrated power meter and a cable adapter provided by the manufacturer. The data of the cable and related circuit losses are also provided by the manufacturer. The power measurement is then performed across the operational band and the channel with the highest output power is recorded.

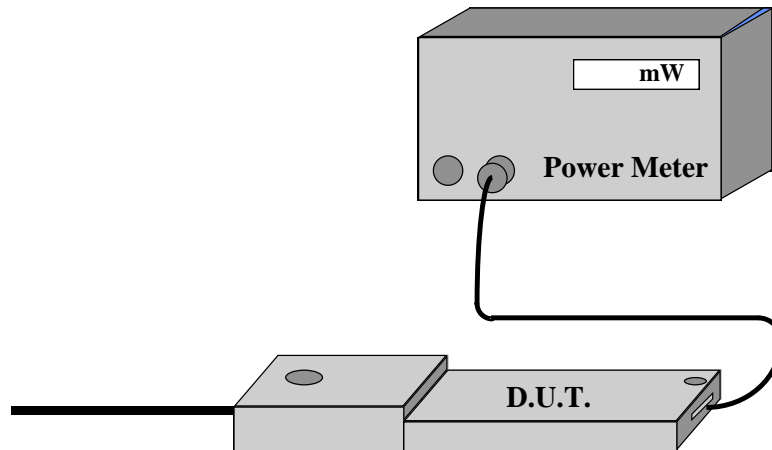

Power measurement is performed before and after the SAR to verify if the battery was delivering full power at the time of testing. A difference in output power would determine a need for battery replacement and to repeat the SAR test.

7.1.1. RF Conducted output power measurement

Scaling Factors user to obtain Reported SAR data are derived from the maximum tune-up power divided by the measured average conducted power. The measured SAR is only scaled up to obtain the Reported SAR.

Antenna 2 Power Measurements

GHZ	Chan	15.247 (Peak Measurement)				UNII 15.407 (Average)	
		802.11b 11Mb/s	802.11g 6Mbps/s	802.11n MCS7	802.11n Mimo Ant1/Ant2	802.11a 6Mb/s	802.11n MSC0
		Meas (dBm)	Meas (dBm)	Meas (dBm)	Meas (dBm)	Meas (dBm)	Meas (dBm)
2412	1	18.60	18.53	19.11	16.72 / 19.45		
2437	6	18.00	19.42	19.26	19.11 / 19.89		
2462	11	17.83	18.81	19.11	19.11 / 19.57		
5180	36					15.84	15.66
5200	40					15.27	15.23
5220	44					15.36	15.26
5240	48					15.06	14.56
5260	52					13.62	13.87
5280	56					13.85	13.76
5300	60					13.88	13.95
5320	64					13.34	13.51
5500	100					14.66	14.63
5520	104					14.90	15.64
5540	108					15.50	16.15
5560	112					16.22	16.33
5580	116					16.89	16.30
5600	120					16.80	16.09
5620	124					16.95	16.71
5640	128					16.69	16.35
5660	132					16.71	16.50
5680	136					17.05	16.41
5700	140					11.78	12.21
5745	149					10.25	10.51
5765	153					15.21	14.67
5785	157					14.66	14.45
5805	161					14.41	14.12
5825	165					13.87	12.83

ULTRATECH GROUP OF LABS

3000 Bristol Circle, Oakville, Ontario, Canada L6H 6G4
 Tel. #: 905-829-1570, Fax. #: 905-829-8050, Email: vic@ultratech-labs.com, Website: <http://www.ultratech-labs.com>

File #: LIB-073Q-SAR
 February 20, 2017

- All test results contained in this engineering test report are traceable to National Institute of Standards and Technology (NIST)

Antenna 1 Power Measurements

GHZ	Chan	15.247 (Peak Measurement)				UNII 15.407 (Average)	
		802.11b 11Mb/s	802.11g 6Mbps/s	802.11n MCS7	802.11n Mimo Ant1/Ant2	802.11a 6Mb/s	802.11n MSC0
		Meas (dBm)	Meas (dBm)	Meas (dBm)	Meas (dBm)	Meas (dBm)	Meas (dBm)
2412	1	18.12	20.27	20.76	16.72 / 19.45		
2437	6	18.12	20.35	20.53	19.11 / 19.89		
2462	11	18.00	20.46	20.61	19.11 / 19.57		
5180	36					14.95	15.32
5200	40					14.75	14.68
5220	44					15.15	15.15
5240	48					14.40	14.31
5260	52					14.53	13.22
5280	56					14.66	13.51
5300	60					14.33	13.20
5320	64					14.60	13.35
5500	100					15.40	13.99
5520	104					15.90	15.35
5540	108					15.16	15.50
5560	112					16.68	15.88
5580	116					17.04	16.32
5600	120					16.98	16.05
5620	124					16.80	16.40
5640	128					17.11	16.88
5660	132					16.92	16.77
5680	136					17.01	16.42
5700	140					12.10	11.90
5745	149					10.50	10.76
5765	153					15.22	15.28
5785	157					15.26	15.20
5805	161					15.10	14.60
5825	165					14.35	13.40

ULTRATECH GROUP OF LABS

3000 Bristol Circle, Oakville, Ontario, Canada L6H 6G4
 Tel. #: 905-829-1570, Fax. #: 905-829-8050, Email: vic@ultratech-labs.com, Website: <http://www.ultratech-labs.com>

File #: LIB-073Q-SAR

February 20, 2017

- All test results contained in this engineering test report are traceable to National Institute of Standards and Technology (NIST)

EXHIBIT 8. TISSUE DIELECTRIC PARAMETER CALIBRATION

8.1. SIMULATED TISSUE

Simulated Tissue: Suggested in a paper by George Hartsgrrove and colleagues in University of Ottawa Ref.: Bioelectromagnetics 8:29-36 (1987)

Ingredient	Quantity
Water	40.4 %
Sugar	56.0 %
Salt	2.5 %
HEC	1.0 %
Bactericide	0.1 %

Table 8.1 Example of composition of simulated tissue

This simulated tissue is mainly composed of water, sugar and salt. At higher frequencies, in order to achieve the proper conductivity, the solution does not contain salt. Also, at these frequencies, D.I. water and alcohol is preferred.

Target Frequency (MHz)	Head		Body	
	ϵ_r	σ (S/m)	ϵ_r	σ (S/m)
150	52.3	0.76	61.9	0.80
300	45.3	0.87	58.2	0.92
450	43.5	0.87	56.7	0.94
835	41.5	0.90	55.2	0.97
900	41.5	0.97	55.0	1.05
915	41.5	0.98	55.0	1.06
1450	40.5	1.20	54.0	1.30
1610	40.3	1.29	53.8	1.40
1800 – 2000	40.0	1.40	53.3	1.52
2450	39.2	1.80	52.7	1.95
3000	38.5	2.40	52.0	2.73
5800	35.3	5.27	48.2	6.00

(ϵ_r = relative permittivity, σ = conductivity and $\rho = 1000 \text{ Kg/m}^3$ *)

* The actual mass density of the equivalent tissue varies based on the composition of the tissue from 990 Kg/m^3 to $1,300 \text{ Kg/m}^3$.

ULTRATECH GROUP OF LABS

3000 Bristol Circle, Oakville, Ontario, Canada L6H 6G4
 Tel. #: 905-829-1570, Fax. #: 905-829-8050, Email: vic@ultratech-labs.com, Website: <http://www.ultratech-labs.com>

File #: LIB-073Q-SAR

February 20, 2017

- All test results contained in this engineering test report are traceable to National Institute of Standards and Technology (NIST)

8.2. MEASUREMENT OF ELECTRICAL CHARACTERISTICS OF SIMULATED TISSUE

HP Dielectric Strength Probe System (open-ended coaxial transmission-line probe/sensor) was used.

8.2.1. Equipment set-up

The equipment consists of a probe connected to one port of a vector network analyzer. The probe is an open-ended coaxial line, as shown in Figure 9.2.1.1. Cylindrical coordinates (ρ , ϕ , z) are used where ρ is the radial distance from the axis, ϕ is the angular displacement around the axis, z is the displacement along the axis, a is the inner conductor radius, and b is the outer conductor inner radius.

The sample holder is a non-metallic container that is large compared with the size of the probe immersed in it. A probe with an outer diameter b of 2 to 4 mm is suitable for the measurement of tissue-equivalent materials in the 300 MHz to 3 GHz frequency range. This probe size is commensurate with sample volumes of 50 cc or higher. Larger probes of up to 7 mm outer diameter b may be used with larger sample volumes. A flange is typically included to better represent the infinite ground-plane assumption used in admittance calculations.

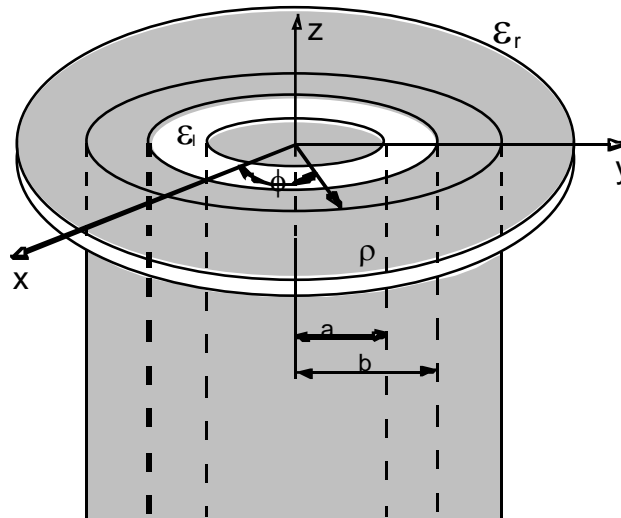

Figure 8.2.1. An open-ended coaxial probe with inner and outer radii a and b , respectively

The accuracy of the short-circuit measurement should be verified for each calibration at a number of frequencies. A short circuit can be achieved by gently pressing a piece of aluminum foil against the open end. For best electrical contact, the probe end should be flat and free of oxidation. Larger the sensors generally have better foil short-circuit repeatability. It is possible to obtain good contact with some commercial 4.6 mm probes using the metal-disk short-circuit supplied with the kit. For best repeatability, it may be necessary to press the disk by hand.

The network analyzer is configured to measure the magnitude and phase of the admittance. A one-port reflection calibration is performed at the plane of the probe by placing materials for which the reflection coefficient can be calculated in contact with the probe. Three standards are needed for the calibration, typically a short circuit, air, and de-ionized water at a well-defined temperature (other reference liquids such as methanol or ethanol may be used for calibration). The calibration is a key part of the measurement procedure, and it is therefore important to ensure that it has been performed correctly. It can be checked by re-measuring the short circuit to ensure that a reflection coefficient of $\Gamma = -1.0$ (linear units) is obtained consistently.

8.2.2. *Measurement procedure*

- a) Configure and calibrate the network analyzer and probe system.
- b) Place the sample in a non-metallic container and immerse the probe. A fixture or clamp is recommended to stabilize the probe, mounted such that the probe face is at an angle with respect to the liquid surface to minimize trapped air bubbles beneath the flange.
- c) Measure the complex admittance with respect to the probe aperture.
- d) Compute the complex relative permittivity $\epsilon_r = \epsilon'_r - j\sigma/\omega\epsilon_0$.

8.3. SIMULATED TISSUE MEASUREMENT RESULTS

Tissue calibration type	HP Dielectric Strength Probe System (M/N: 85070C)	
Tissue calibration date [MM/DD/YYYY]	1/23/2017	2/02/2017
Tissue calibrated by	Max Kee	Max Kee
Room temperature [°C]	21	21
Room humidity [%]	40	35
Simulated tissue temperature (°C)	21	21
Tissue calibration frequency [MHz]	2450	5500
Tissue Type	Muscle	Muscle
Target conductivity [S/m]	1.95	6.0
Target dielectric constant	52.7	48.2
Composition (by weight) [%]	DGBE (13.80 %) Salt (0.19 %) Triton X-100 (13.59 %) DI Water (72.42 %)	DGBE (3.50 %) Salt (0.1 %) Triton X-100 (37 %) DI Water (64%)
Measured conductivity [S/m]	1.92 (-1.7%)	6.0 (6.1%)
Measured dielectric constant	51.9 (-1.7%)	46.3 (-4.7%)
Penetration depth (plane wave excitation) [mm]	20.1	6.2

8.3.1. 2450 MHz Muscle Tissue

Frequency [MHz]	Meas. after 5min			DI Water at 20°C			Init. Meas.		
	ϵ'	ϵ''	σ [S/m]	ϵ'	ϵ''	σ [S/m]	ϵ'	ϵ''	σ [S/m]
2350.000	52.1625	13.7771	1.80	78.0052	9.9624	1.30	52.1349	13.6995	1.79
2450.000	51.9375	14.0686	1.92	77.8430	10.3546	1.41	51.8976	14.0256	1.91
2550.000	51.6323	14.4439	2.05	77.6736	10.7362	1.52	51.6094	14.3982	2.04

8.3.2. 5500 MHz Muscle Tissue

Frequency [MHz]	Meas. after 5min			DI Water at 20°C			Init. Meas.		
	ϵ'	ϵ''	σ [S/m]	ϵ'	ϵ''	σ [S/m]	ϵ'	ϵ''	σ [S/m]
5200.000	47.1315	19.0898	5.52	73.3272	20.6980	5.99	46.8185	19.0131	5.50
5500.000	46.2976	19.5976	6.00	72.5631	21.8469	6.68	45.8167	19.5359	5.98
5800.000	45.3885	20.0550	6.47	71.9775	22.6209	7.30	45.1122	20.0550	6.47

EXHIBIT 9. SAR MEASUREMENT UNCERTAINTY

9.1. MEASUREMENT UNCERTAINTY EVALUATION FOR SAR TEST

Error Description	Uncertainty value	Prob. Dist.	Div.	(c _i) 1g	(c _i) 10g	Std. Unc. (1g)	Std. Unc. (10g)	(v _i) v _{eff}
Measurement System								
Probe Calibration	±5.5 %	N	1	1	1	±5.5 %	±5.5 %	∞
Axial Isotropy	±4.7 %	R	$\sqrt{3}$	0.7	0.7	±1.9 %	±1.9 %	∞
Hemispherical Isotropy	±9.6 %	R	$\sqrt{3}$	0.7	0.7	±3.9 %	±3.9 %	∞
Boundary Effects	±1.0 %	R	$\sqrt{3}$	1	1	±0.6 %	±0.6 %	∞
Linearity	±4.7 %	R	$\sqrt{3}$	1	1	±2.7 %	±2.7 %	∞
System Detection Limits	±1.0 %	R	$\sqrt{3}$	1	1	±0.6 %	±0.6 %	∞
Readout Electronics	±0.3 %	R	$\sqrt{3}$	1	1	±0.3 %	±0.3 %	∞
Response Time	±0.8 %	N	1	1	1	±0.5 %	±0.5 %	∞
Integration Time	±2.6 %	R	$\sqrt{3}$	1	1	±1.5 %	±1.5 %	∞
RF Ambient Noise	±3.0 %	R	$\sqrt{3}$	1	1	±1.7 %	±1.7 %	∞
RF Ambient Reflections	±3.0 %	R	$\sqrt{3}$	1	1	±1.7 %	±1.7 %	∞
Probe Positioner	±0.4 %	R	$\sqrt{3}$	1	1	±0.2 %	±0.2 %	∞
Probe Positioning	±2.9 %	R	$\sqrt{3}$	1	1	±1.7 %	±1.7 %	∞
Max. SAR Eval.	±1.0 %	R	$\sqrt{3}$	1	1	±0.6 %	±0.6 %	∞
Test Sample Related								
Device Positioning	±2.9 %	N	1	1	1	±2.9 %	±2.9 %	145
Device Holder	±3.6 %	N	1	1	1	±3.6 %	±3.6 %	5
Power Drift	±5.0 %	R	$\sqrt{3}$	1	1	±2.9 %	±2.9 %	∞
Phantom and Setup								
Phantom Uncertainty	±4.0 %	R	$\sqrt{3}$	1	1	±2.3 %	±2.3 %	∞
Liquid Conductivity (target)	±5.0 %	R	$\sqrt{3}$	0.64	0.43	±1.8 %	±1.2 %	∞
Liquid Conductivity (meas.)	±2.5 %	N	1	0.64	0.43	±1.6 %	±1.1 %	∞
Liquid Permittivity (target)	±5.0 %	R	$\sqrt{3}$	0.6	0.49	±1.7 %	±1.4 %	∞
Liquid Permittivity (meas.)	±2.5 %	N	1	0.6	0.49	±1.5 %	±1.2 %	∞
Combined Std. Uncertainty						±10.7 %	±10.5 %	387
Expanded STD Uncertainty						±21.4 %	±21.0 %	

ULTRATECH GROUP OF LABS

3000 Bristol Circle, Oakville, Ontario, Canada L6H 6G4
 Tel. #: 905-829-1570, Fax. #: 905-829-8050, Email: vic@ultratech-labs.com, Website: <http://www.ultratech-labs.com>

File #: LIB-073Q-SAR

February 20, 2017

- All test results contained in this engineering test report are traceable to National Institute of Standards and Technology (NIST)

EXHIBIT 10. ADDITIONAL TEST INSTRUMENTS LIST

Name	Type	Serial Number (SN)	Calibration Due Date
Signal Generator(Rohde & Schwartz)	SMIQ06B	DE26709	Jul 20, 2017
Dipole Antenna(Speag)	D2450V2	821	Aug 18, 2016
Dipole Antenna(Speag)	D5GHzV2	1069	Aug 213 2016
SAR Probe(Speag)	EX3DV4	3673	Aug 29, 2016
Power Meter(HP)	HP 438A	3008A06729	Apr 19, 2017
Directional Coupler (narda)	Model 3020A	35482	Cal on use
Network Analyzer (HP)	8753D	3410A06430	Mar 23, 2016
Ophir Amplifier 0.8-4.2GHz 13W	Model GRF5058	1009	N/A
Hughes TWT Amplifier 3-8GHz 10W	1177H13F000	071	N/A

EXHIBIT 11. SAR MEASUREMENT DATA

See Appendix 1.

EXHIBIT 12. SAR CALIBRATION CERTIFICATES

See Appendix 2.

ULTRATECH GROUP OF LABS

3000 Bristol Circle, Oakville, Ontario, Canada L6H 6G4
Tel. #: 905-829-1570, Fax. #: 905-829-8050, Email: vic@ultratech-labs.com, Website: <http://www.ultratech-labs.com>

File #: LIB-073Q-SAR

February 20, 2017

- All test results contained in this engineering test report are traceable to National Institute of Standards and Technology (NIST)