

**COMPLIANCE WORLDWIDE INC.
TEST REPORT 197-11R1**

In Accordance with the Requirements of
Industry Canada RSS 213, Issue 2, December 2005
2 GHz License-exempt Personal Communications Service Devices (LE-PCS)

Federal Communications Commission 47 CFR Part 15, Subpart D
Technical Requirements for
Unlicensed Personal Communication Systems (UPCS)

Issued to

**Revolabs, Inc.
144 North Road, Suite 3250
Sudbury, MA 01776**

For the
**flx Base Station
Model Number: 10-FLXBASE-POTS**

**FCC ID: T5V10FLX
IC: 6455A-10FLX**

Report Issued on August 26, 2011

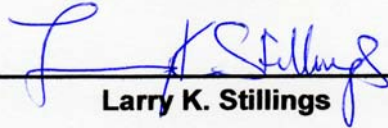

Larry K. Stillings

Reviewed By



Brian F. Breault

This test report shall not be reproduced, except in full, without written permission from Compliance Worldwide, Inc.

Table of Contents

1. Scope.....	3
2. Product Details.....	3
2.1. Manufacturer.....	3
2.2. Model Number.....	3
2.3. Serial Number.....	3
2.4. Description.....	3
2.5. Power Source.....	3
2.6. Hardware Revision.....	3
2.7. Software Revision.....	3
2.8. Modulation Type.....	3
2.9. Operating Frequency.....	3
2.10. Emission Designator.....	3
2.11. EMC Modifications.....	3
3. Product Configuration.....	3
3.1. Cables.....	3
3.2. EUT Hardware.....	3
3.3. Support Equipment.....	4
3.4. EUT Diagram.....	4
3.6. Test Setup Diagram.....	4
4. Measurements Parameters.....	5
4.1. Measurement Equipment Used to Perform Test.....	5
4.2. Measurement & Equipment Setup.....	6
4.3. Measurement Procedure.....	6
4.4. Choice of Operating Frequencies.....	6
5. Measurement Summary.....	7
6. Measurement Data.....	8
6.1. Antenna Gain.....	8
6.2. Type of Modulation and Access Protocol.....	8
6.3. Peak Transmit Power.....	9
6.4. Emission Bandwidth.....	11
6.5. Spurious Emissions at the antenna terminals.....	16
6.6. Power Spectral Density.....	25
6.7. Regulatory Limit: FCC Part 15.315, 15.207, IC RSS-213 6.3, RSS-GEN.....	27
6.8. Frequency Stability.....	30
6.9. Receiver Spurious Emissions.....	31
6.10. Specific Requirements to UPCS Devices.....	35
6.11. Public Exposure to Radio Frequency Energy Levels.....	48
7. Test Images.....	49
8. Test Site Description.....	53

1. Scope

This test report certifies that the Revolabs, Inc. flx Base Station, as tested, meets the FCC Part 15, Subpart D and Industry Canada RSS 213 requirements. The scope of this test report is limited to the test sample provided by the client, only in as much as that sample represents other production units. If any significant changes are made to the unit, the changes shall be evaluated and a retest may be required. R1 adds spurious emissions from 25 MHz to 30 MHz.

2. Product Details

- 2.1. **Manufacturer:** Revolabs, Inc.
- 2.2. **Model Number:** 10-FLXBASE-POTS
- 2.3. **Serial Number:** 7010F0000439
- 2.4. **Description:** flx Base Station for Conference Room Microphone system
- 2.5. **Power Source:** 5 VDC power adapter
- 2.6. **Hardware Revision:** Rev E
- 2.7. **Software Revision:** N/A
- 2.8. **Modulation Type:** GFSK
- 2.9. **Operating Frequencies:** 1921.536 -1928.448 MHz
- 2.10. **Emission Designator:** 1M48F7E (FCC), 1M20F7E (IC)
- 2.11. **EMC Modifications:** None

3. Product Configuration

3.1. Cables

Part #	Shielded Y or N	Length	Function / Description
N/A	Y	1 m	USB to Micro USB
N/A	N	2 m	Power Supply Cable

3.2. EUT Hardware

Device	Manufacturer	Model	Serial No.	Comment
flx Base Station	Revolabs	10-FLX2BASE-POTS 10-FLX4BASE-POTS 10-FLX2BASE-VOIP 10-FLX4BASE-VOIP	7010F0000465	Used for field strength measurements ¹
flx Base Station	Revolabs	MBT-9166		Used for conducted measurements ¹
Power Supply	Teking	PAS05AA-W00501000	N/A	5 Volt, 1 Amp supply

3. Product Configuration (continued)

3.3. Support Equipment

Manufacturer	Model/Part #	Input Voltage	Input Freq	Description/Function
Dell	Latitude D620	120V	60	Software Control via USB

3.4 EUT Diagram

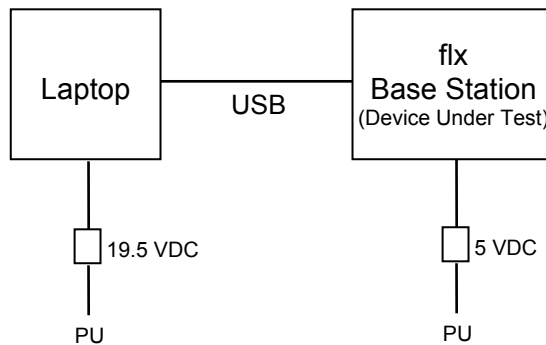

Channel Plan	Channel	Frequency (MHz)	
Measure	0	1928.448	Note: The channel numbers count down vs frequency
	1	1926.720	
Measure	2	1924.992	
	3	1923.264	
Measure	4	1921.536	

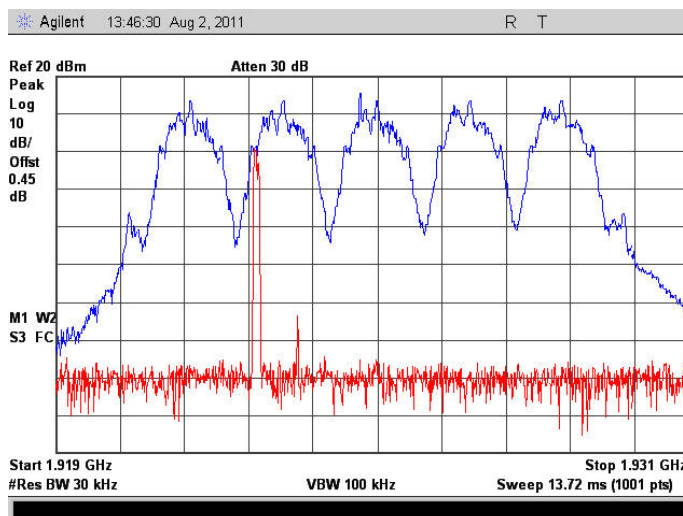

4. Measurements Parameters

4.1. Measurement Equipment Used to Perform Test

Device	Manufacturer	Model No.	Serial No.	Cal Due
Spectrum Analyzer	Agilent	E7405A	MY45115430	10/22/2012
Spectrum Analyzer	Agilent	E4407B	MY45104493	12/22/2012
EMI Receiver	Hewlett Packard	8546A	3330A00115	10/28/2011
Microwave Preamp 1 to 26.5 GHz	Hewlett Packard	8449B	3008A01323	12/1/2012
Loop Antenna 25 to 30 MHz	EMCO	6502	2197	7/22/2012
Bilog Antenna 30 to 2000 MHz	Com-Power	AC-220	25509	8/30/2011
Horn Antenna 1 to 18 GHz	Electro-Metrics	EM-6961	6337	10/19/2012
Horn Antenna 18 to 26.5 GHz	Com-Power	AH-826	081051	06/30/2012
High Pass Filter 2.5 to 20 GHz	Micro-Tronics	HPM50110	070	06/25/2012
DMM / Temperature	Fluke	187	79690058	11/18/2011
Barometer	Control Company	4195	Cal ID# 236	11/09/2011
Thermal Chamber	Associated Testing	SLHU-1-CRLC	N/A	CNR
Directional Coupler 1.7 – 26.5 GHz	Narda Microwave	4227-16	03034	11/01/2012
Digital Radio Communication Tester	Rohde & Schwarz	CTS65	829877/006	11/02/2012
RF Signal Generator	Hewlett Packard	8648C	3642U01557	07/16/2011
RF Signal Generator	Rohde & Schwarz	SMIQ06B	100090	12/17/2012
Modulation Generator	Rohde & Schwarz	AMIQ04	100540	CBU
DC Source 0-60 Volts, 0-3 Amps	Hewlett Packard	6296A	7M0599	12/10/2011
Power Splitter Resistive DC – 4.2 GHz	RF Bay	PSC-2R-42	14110124	01/14/2012
Power Splitter Resistive DC – 4.2 GHz	RF Bay	PSC-2R-42	14110125	01/14/2012
Power Splitter Resistive DC – 4.2 GHz	RF Bay	PSC-2R-42	14110126	01/14/2012

4. Measurements Parameters (continued)

4.2. Measurement & Equipment Setup

Test Date:	4/1/2011 – 6/1/2011
Test Engineer:	Larry Stillings
Normal Site Temperature (15 – 35 °C):	21.6 °C
Relative Humidity (20 – 75 %RH):	35 %
Frequency Range:	30 MHz to 19.3 GHz
Measurement Distance:	3 Meters or 1 Meter as necessary
EMI Receiver IF Bandwidth:	120 kHz - 30 MHz to 1000 MHz 1 MHz - Above 1000 MHz
EMI Receiver Avg Bandwidth:	300 kHz - 30 MHz to 1000 MHz 3 MHz - Above 1000 MHz
Detector Function:	Peak, Quasi-Peak, EMI Average and RMS Average

4.3. Measurement Procedure

Test measurements were made in accordance FCC Part 15.315, 15.317, 15.319, 15.323, IC RSS-213 Issue 2, and ANSI C63.17:2006.

The test methods used to generate the data in this test report is in accordance with ANSI C63.17:2006, American National Standard Methods of Measurement of the Electromagnetic and Operational Compatibility of Unlicensed Personal Communications Services (UPCS) Devices.

4.4. Measurement Uncertainty

The following uncertainties are expressed for an expansion/coverage factor of K=2.

RF Frequency (out of band)	$\pm 1 \times 10^{-8}$
Radiated Emission of Transmitter to 20 GHz	± 4.55 dB
Radiated Emission of Receiver	± 4.55 dB
Temperature	$\pm 0.91^{\circ}$ C
Humidity	$\pm 5\%$

5. Measurements Summary

Test Requirement	FCC Rule Requirement	IC Rule Requirement	Test Report Section	Result	Comment
Antenna Requirement	15.317 15.203	RSS-GEN 7.1.4	6.1	Compliant	Equipment uses an PCB Mounted Ant
Antenna Gain	15.319(e)	RSS 213 4.1(e)	6.1	Compliant	2.5 dBi Maximum
Type of Modulation and Access Protocol	15.303 15.307	RSS-213 6.1	6.2	Compliant	Device uses GFSK Digital Modulation
Peak Transmit Power	15.303(f)	RSS-213 6.5	6.3	Compliant	
Emission Bandwidth Occupied Bandwidth	15.303(c)	RSS-213 6.4	6.4	Compliant	
Spurious Conducted Emissions – Antenna Port	15.323 (d) 15.319 (g)	RSS-213 6.7	6.5	Compliant	
Spurious Radiated Emissions for integral antennas	15.323 (d) 15.319 (g) 15.209	RSS-213 6.7	6.5	Compliant	
Power Spectral Density	15.319 (d)	RSS-213 6.6	6.6	Compliant	
Conducted Emissions	15.315 15.207	RSS-213 6.3 RSS-GEN	6.7	Compliant	
Frequency Stability	15.323 (f)	RSS-213 6.2	6.8	Compliant	
Receiver Spurious Emissions	N/A	RSS-213 6.8	6.9	Compliant	
Specific Requirements for UPCS	15.323 (c) 15.323 (e)	RSS-213 4.3.4 RSS-213 6.1	6.10	Compliant	
Radio Frequency Exposure	15.319 (i) 2.1091 FCC OET Bulletin 65	RSS-GEN	6.11	Compliant	

6. Measurement Data

6.1. Antenna Requirement (15.317, 15.203), RSS-GEN Section 7.1.4

Requirement: An intentional radiator shall be designed to ensure that no antenna other than that furnished by the responsible party shall be used with the device. The use of a permanently attached antenna or of an antenna that uses a unique coupling to the intentional radiator shall be considered sufficient to comply. Further, this requirement does not apply to intentional radiators that must be professionally installed, such as perimeter protection systems and some field disturbance sensors, or to other intentional radiators which, in accordance with § 15.31(d), must be measured at the installation site. However, the installer shall be responsible for ensuring that the proper antenna is employed so that the limits in this part are not exceeded.

Result: The EUT incorporates two PCB mounted antennas for antenna diversity.

6.1.1 Antenna Gain (15.319 (e)), RSS-213 Section 4.1(e)

Requirement: The peak transmit power shall be reduced by the amounts in decibels that the maximum directional gain of the antenna exceeds 3 dBi

Result: Compliant, the EUT uses two PCB Mount antennas with a gains of 2.5 dBi for antenna diversity.

6.2 Type of Modulation and Access Protocol (15.303, 15.307), RSS-213 Section 4.1(e)

Requirement: UTAM, Inc. is designated to coordinate and manage the transition of the 1910–1930 MHz band from the Private Operational-Fixed Microwave Service (OFS) operating under part 101 of this chapter to unlicensed PCS operations.

Result: A letter from UTAM to Revolabs, Inc. has been provided as part of the submittal.

Requirement: Equipment certified under this standard shall use digital modulation.

Result: The product uses GFSK digital modulation.

6. Measurement Data

6.3. Peak Transmit Power (15.303 (f)), RSS-213 Sec 6.5

Requirement: Peak transmit power shall not exceed 100 microwatts multiplied by the square root of the emission bandwidth in Hertz. Peak transmit power must be measured over any interval of continuous transmission using instrumentation calibrated in terms of an RMS equivalent voltage.

Peak power shall not exceed 100 microwatts multiplied by the square root of the occupied bandwidth in hertz.

EBW = 1430000 Hz, OBW = 1226100 Hz

$P_{max} = 100 \mu W * (EBW)^{1/2} = 100 \mu W * (1482000)^{1/2} = 121.73 mW = 20.85 dBm$

$P_{max} = 100 \mu W * (OBW)^{1/2} = 100 \mu W * (1203500)^{1/2} = 109.70 mW = 20.40 dBm$

Channel	Channel Frequency	Peak Power	Requirement	Peak Power
	MHz	dBm	FCC = 20.85 dBm, IC = 20.40 dBm	Watts
TX4	1921.536	16.13	Compliant	0.041
TX2	1924.992	16.23	Compliant	0.042
TX0	1928.448	16.24	Compliant	0.042

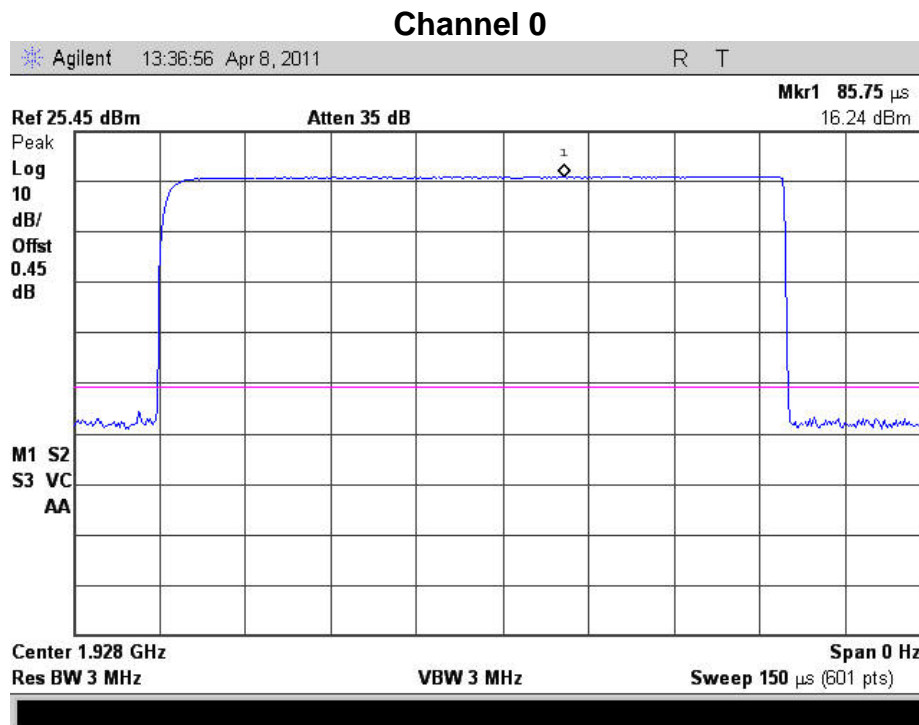

6. Measurement Data

6.3. Peak Transmit Power (15.303 (f)), RSS-213 Sec 6.5

Channel 2

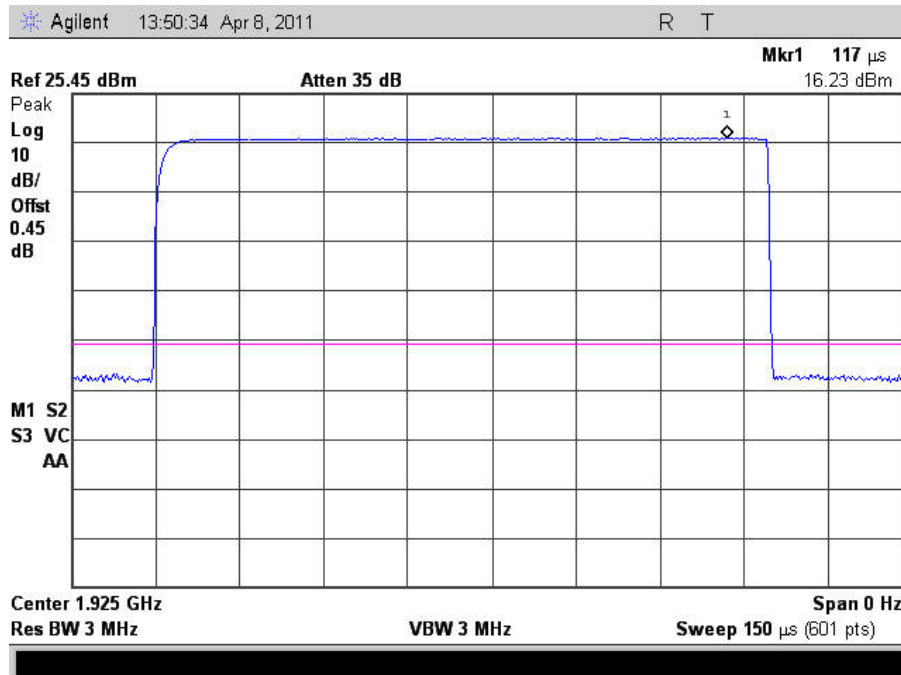

Channel 4

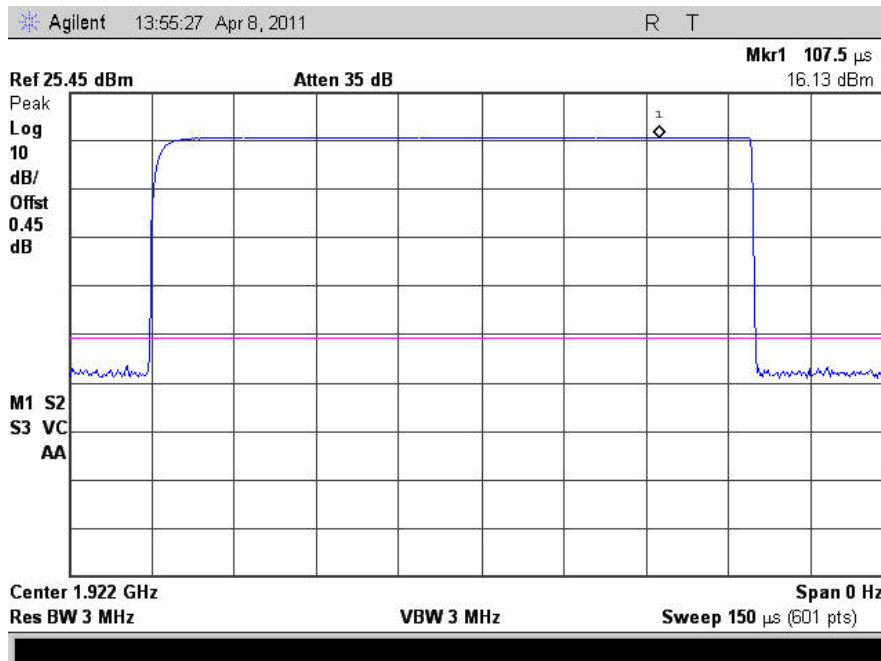

6. Measurement Data

6.4. Emission Bandwidth (15.303 (c) 15.232 (a), RSS-213 Section 6.4

Requirement: Operation shall be contained within the 1920–1930 MHz band. The emission bandwidth shall be less than 2.5 MHz. The power level shall be as specified in § 15.319(c), but in no event shall the emission bandwidth be less than 50 kHz.

6.4.1. Measurement Data – 26 dB Emission Bandwidth (EBW)

Channel	Channel Frequency	Emission Bandwidth	Requirement
	MHz	MHz	50 kHz < EBW < 2.5 MHz
TX4	1921.536	1.472	Compliant
TX2	1924.992	1.482	Compliant
TX0	1928.448	1.440	Compliant

6.4.2. Measurement Data – 99% Occupied Bandwidth (OBW)

Channel	Channel Frequency	Occupied Bandwidth	Requirement
	MHz	MHz	50 kHz < OBW < 2.5 MHz
TX4	1921.536	1.2022	Compliant
TX2	1924.992	1.2035	Compliant
TX0	1928.448	1.1949	Compliant

Note: Please see the next pages for plots of measurements

6. Measurement Data (continued)

6.4. Emission Bandwidth (15.303 (c) 15.232 (a), RSS-213 Section 6.4) (continued)

6.4.3. Measurement Plot – TX0

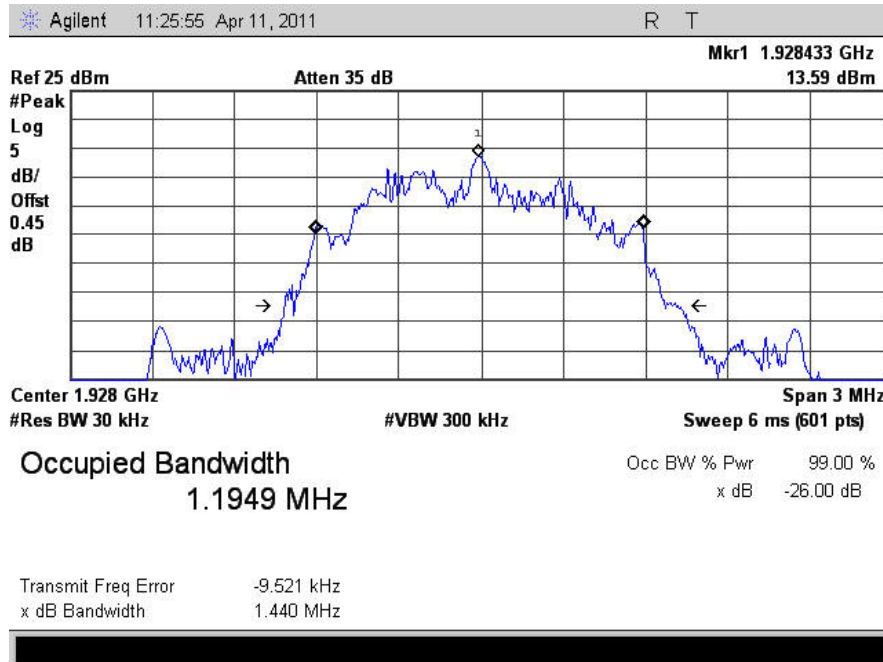

6.4.4. Measurement Plot – TX2

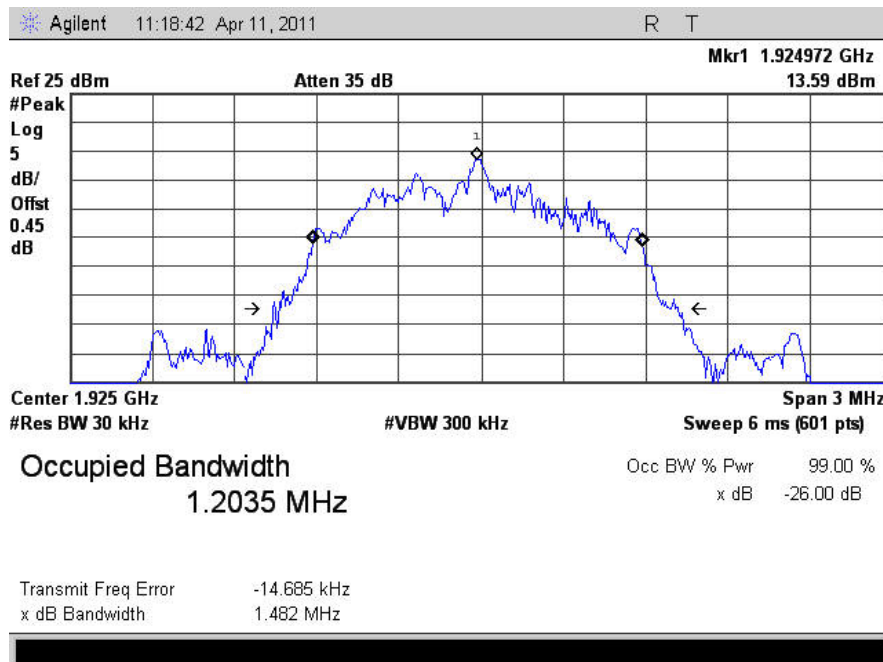

6. Measurement Data (continued)

6.4. Emission Bandwidth (15.303 (c) 15.232 (a), RSS-213 Section 6.4) (continued)

6.4.5. Measurement Plot – TX4

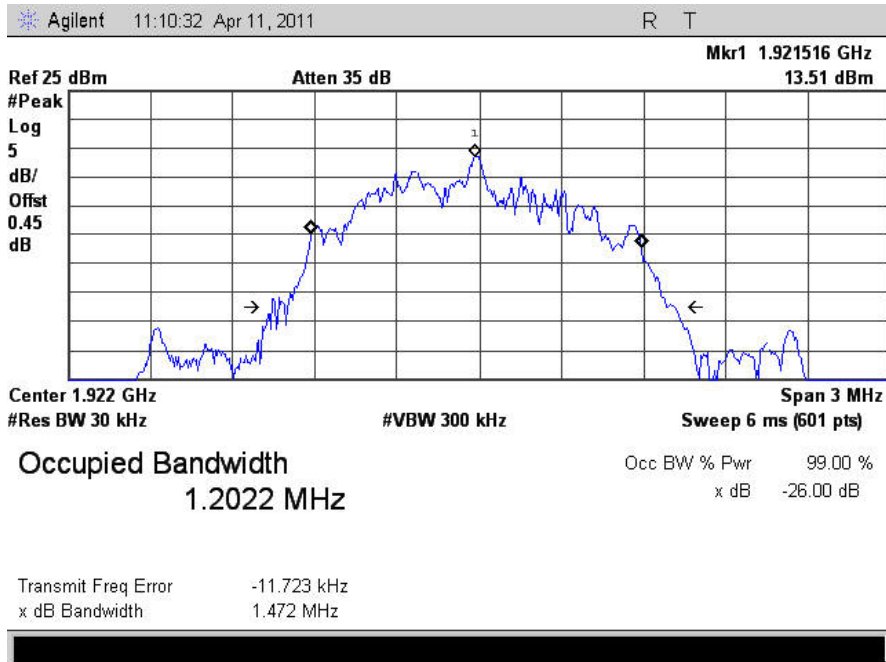

6. Measurement Data (continued)

6.5 Spurious Emissions at the antenna terminals (15.323 (d), RSS-213 6.7.2))

Requirement: Emissions inside the sub-band must comply with the following emission mask: In the bands between 1B and 2B measured from the center of the emission bandwidth the total power emitted by the device shall be at least; 30 dB below the transmit power permitted for that device; in the bands between 2B and 3B measured from the center of the emission bandwidth the total power emitted by an intentional radiator shall be at least 50 dB below the transmit power permitted for that radiator; in the bands between 3B and the subband edge the total power emitted by an intentional radiator in the measurement bandwidth shall be at least 60 dB below the transmit power permitted for that radiator.

- 30 dB between the frequencies 1B and 2B measured from the centre of the occupied bandwidth;
- 50 dB between the frequencies 2B and 3B measured from the centre of the occupied bandwidth; and
- 60 dB between the frequencies 3B and band edge, where B is the occupied bandwidth in hertz.

6.5.1 Low Channel – In Band

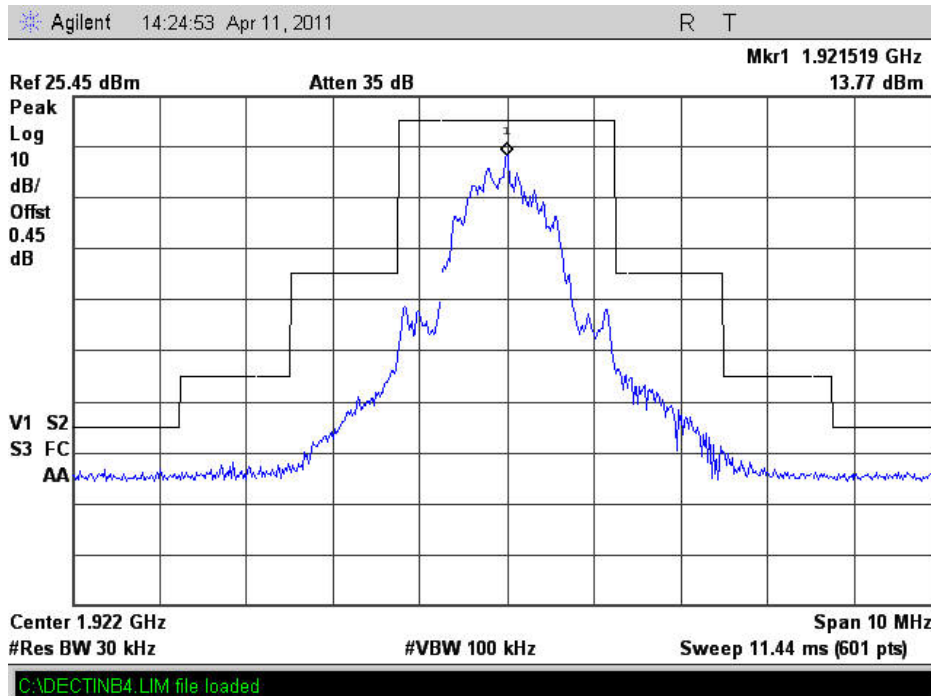

6. Measurement Data (continued)

6.5 Spurious Emissions at the antenna terminals (15.323 (d), RSS-213 6.7.2)) (cont)

6.5.2 Mid Channel – In Band

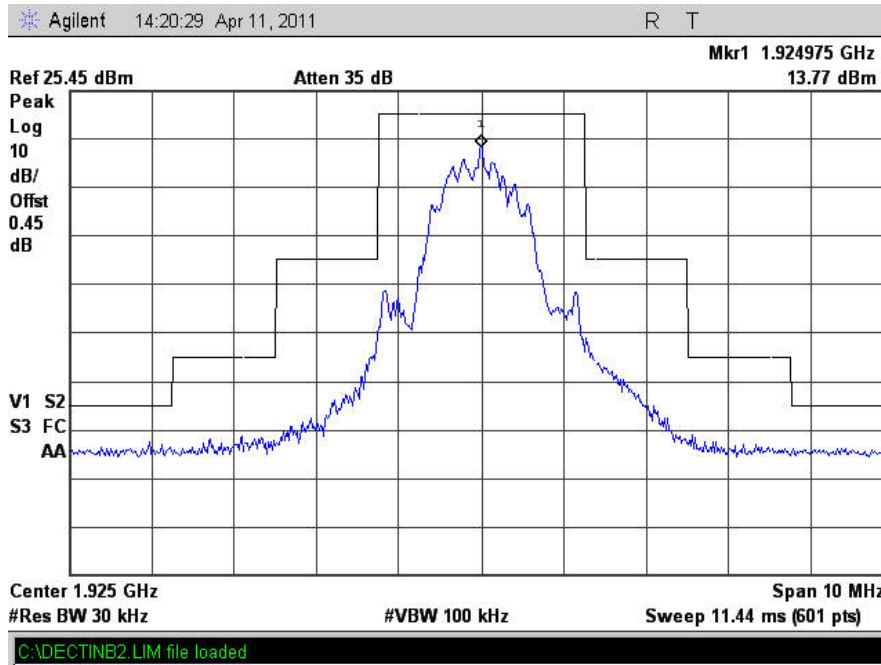

6.5.3 High Channel – In Band

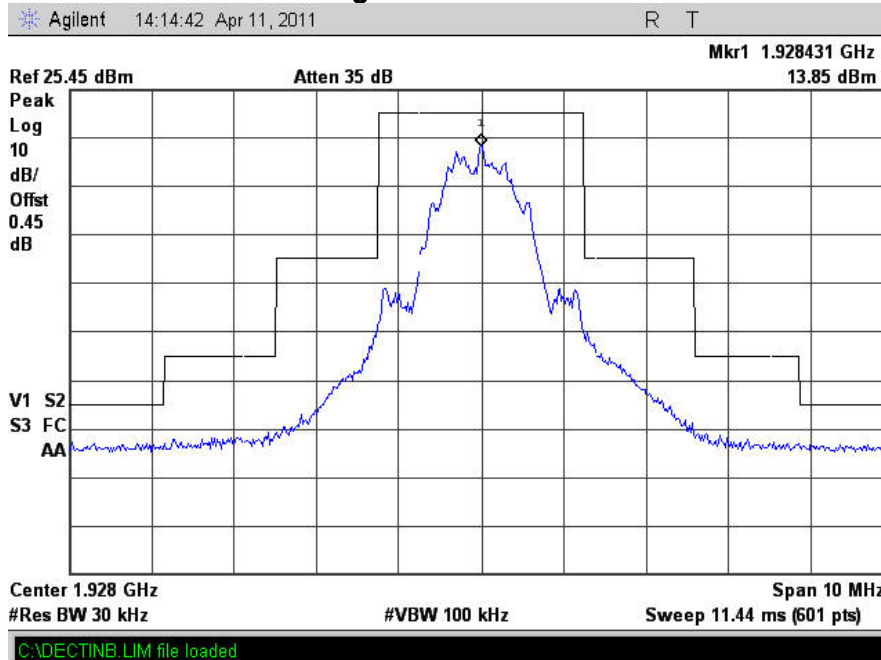

6. Measurement Data (continued)

6.5 Spurious Emissions at the antenna terminals (15.323 (d), RSS-213 6.7.1) (cont)

Requirement: Emissions outside the sub-band shall be attenuated below a reference power of 112 milliwatts as follows: 30 dB between the sub-band and 1.25 MHz above or below the sub-band; 50 dB between 1.25 and 2.5 MHz above or below the sub-band; and 60 dB at 2.5 MHz or greater above or below the sub-band.

Per ANSI C63.17-2006 Clause 6.1.6.2 the emissions in the region 2.5 MHz or greater above and below the limit can either meet the requirements outlined below or be made as a radiated emissions test and not exceed the limits of section 15.209.

Emissions outside the 1920-1930 MHz band shall be attenuated below a reference power of 112 milliwatts (-9.5 dBW) by at least:

- 30 dB between the band edges and 1.25 MHz above and below the band edges;
- 50 dB between 1.25 MHz and 2.5 MHz above or below the band edges; and
- 60 dB at 2.5 MHz or greater above or below the band edges.

6.5.4 Low Channel – Out of Band 30 MHz – 1.915 GHz

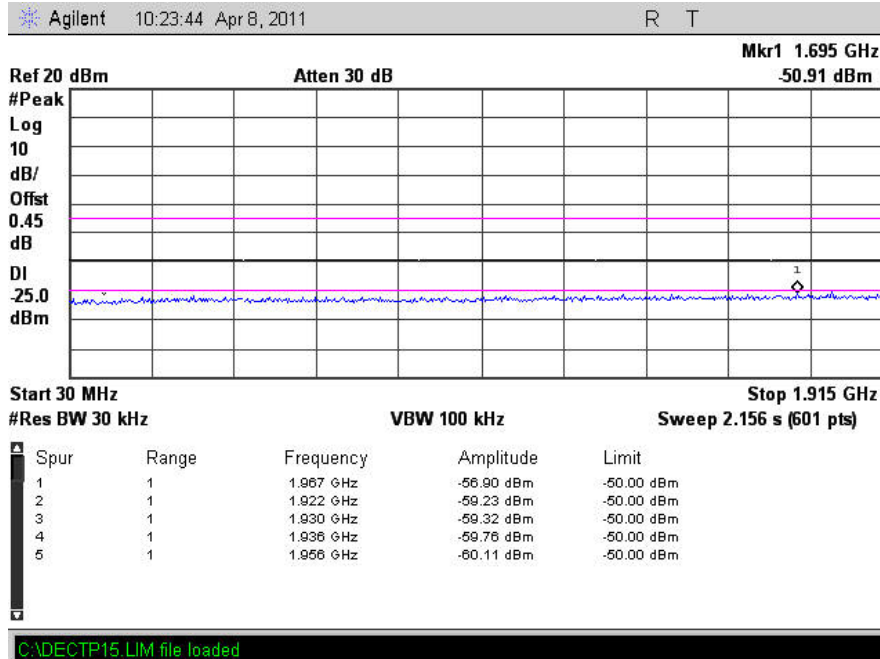

6. Measurement Data (continued)

6.5 Spurious Emissions at the antenna terminals (15.323 (d), RSS-213 6.7.1) (cont)

6.5.5 Low Chanel – Out of Band 1.915 – 1.920 GHz

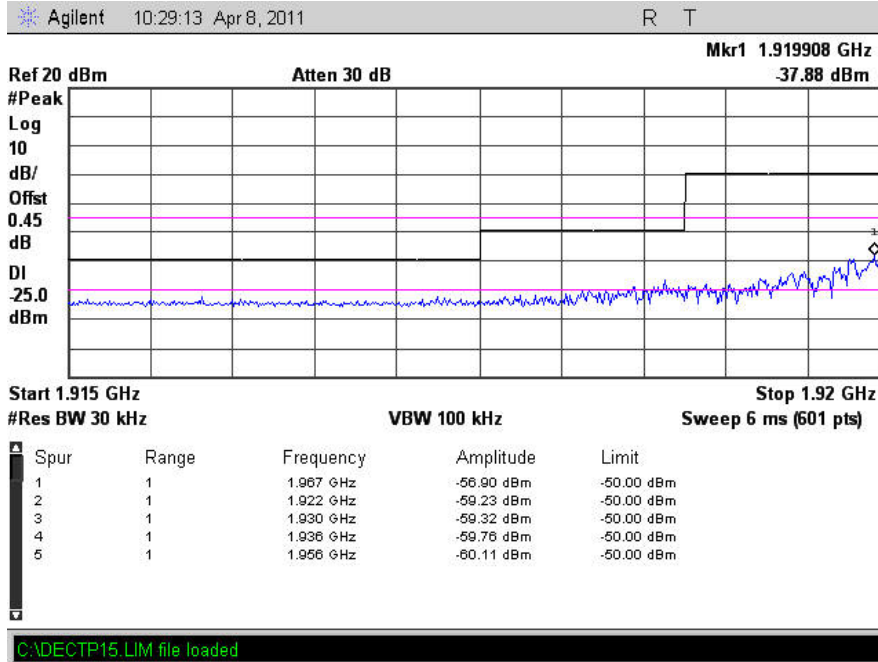

6.5.6 Low Channel Out of Band 1.930 – 1.935 GHz

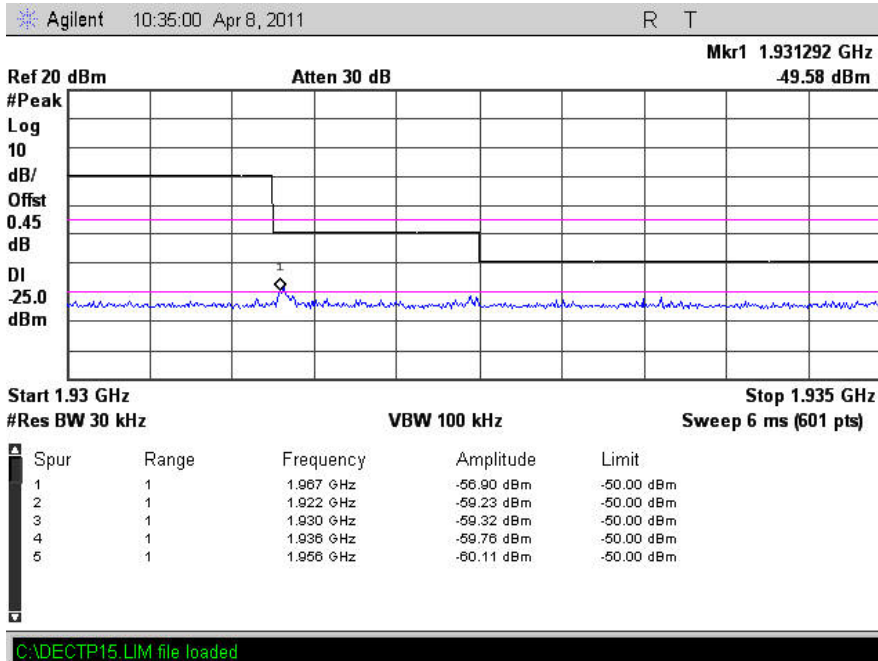

6. Measurement Data (continued)

6.5 Spurious Emissions at the antenna terminals (15.323 (d), RSS-213 6.7.1) (cont)

6.5.7 Low Channel Out of Band 1.935 – 19.3 GHz

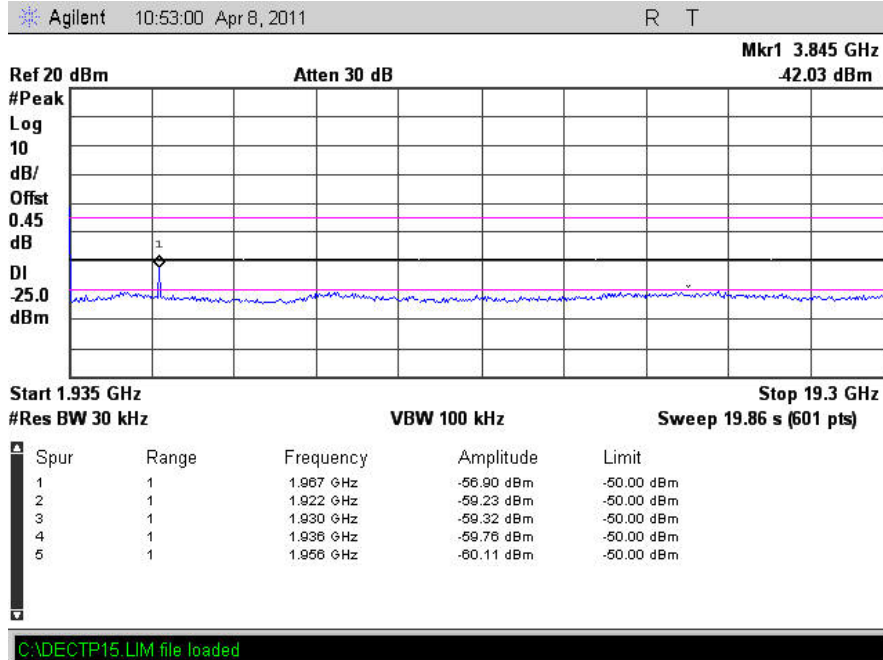

6.5.8 Mid Channel Out of Band 30 MHz – 1.915 GHz

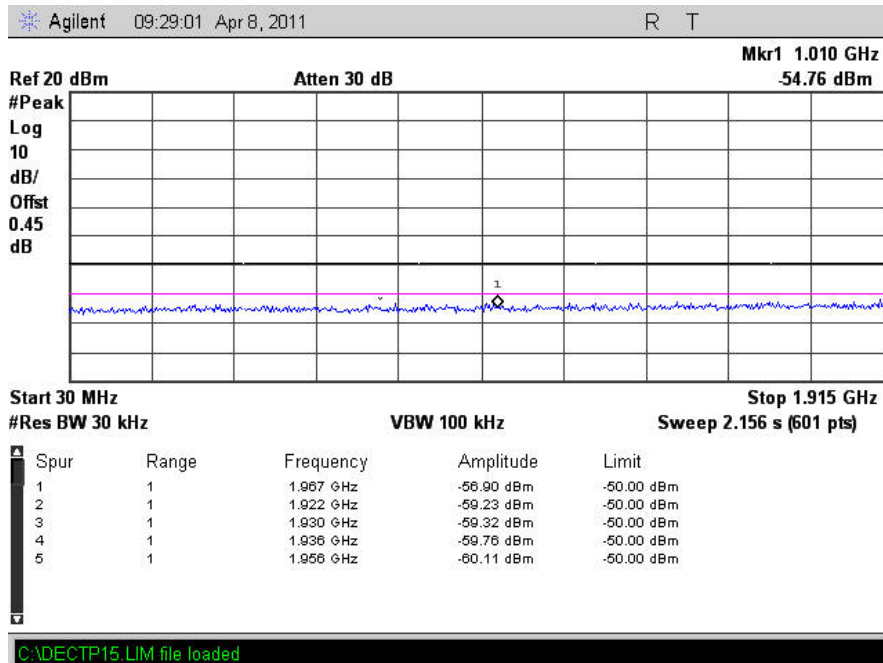

6. Measurement Data (continued)

6.5 Spurious Emissions at the antenna terminals (15.323 (d), RSS-213 6.7.1) (cont)

6.5.9 Mid Channel Out of Band 1.915 – 1.920 GHz

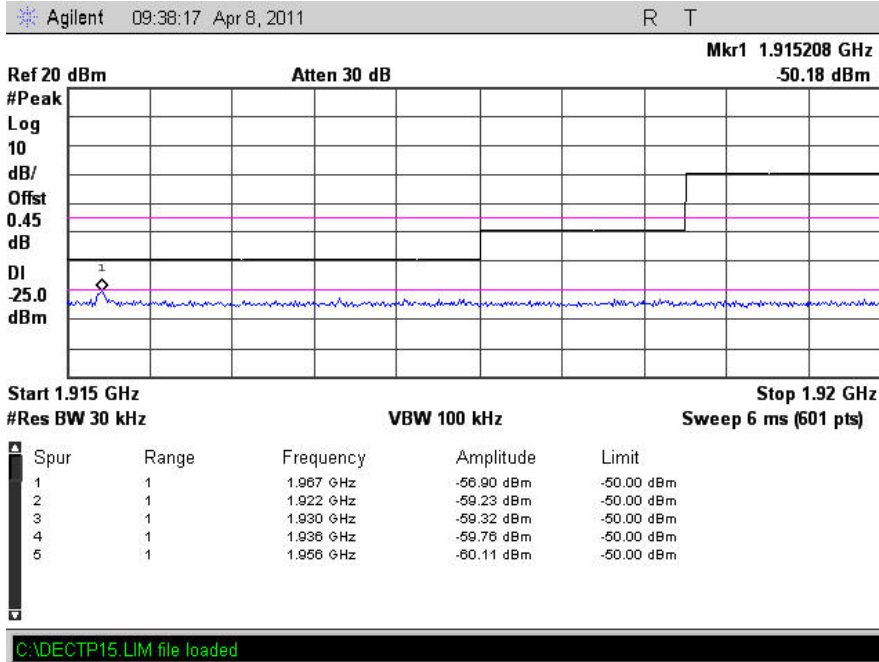

6.5.10 Mid Channel Out of Band 1.930 – 1.935 GHz

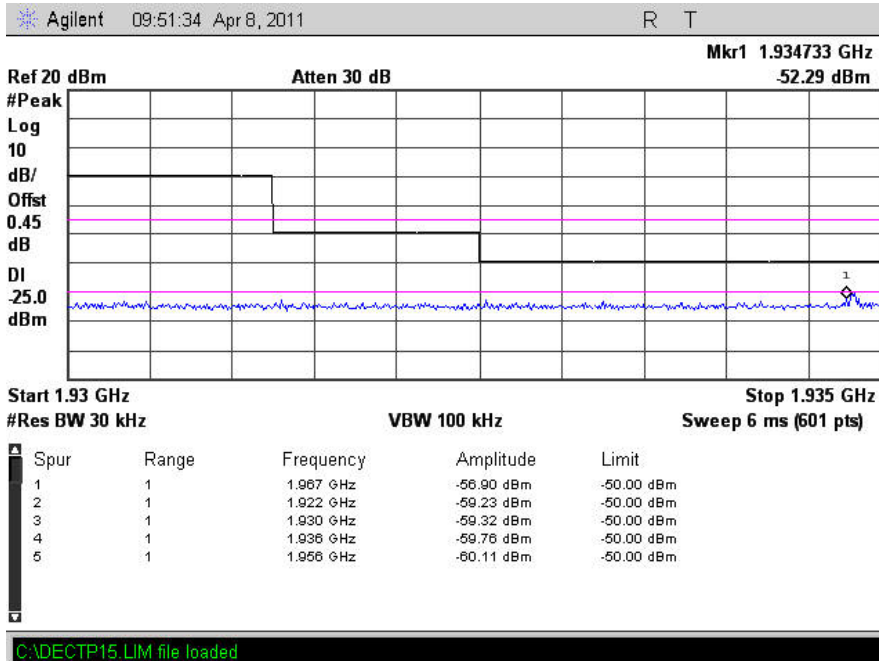

6. Measurement Data (continued)

6.5 Spurious Emissions at the antenna terminals (15.323 (d), RSS-213 6.7.1) (cont)

6.5.11 Mid Channel Out of Band 1.935 – 19.3 GHz

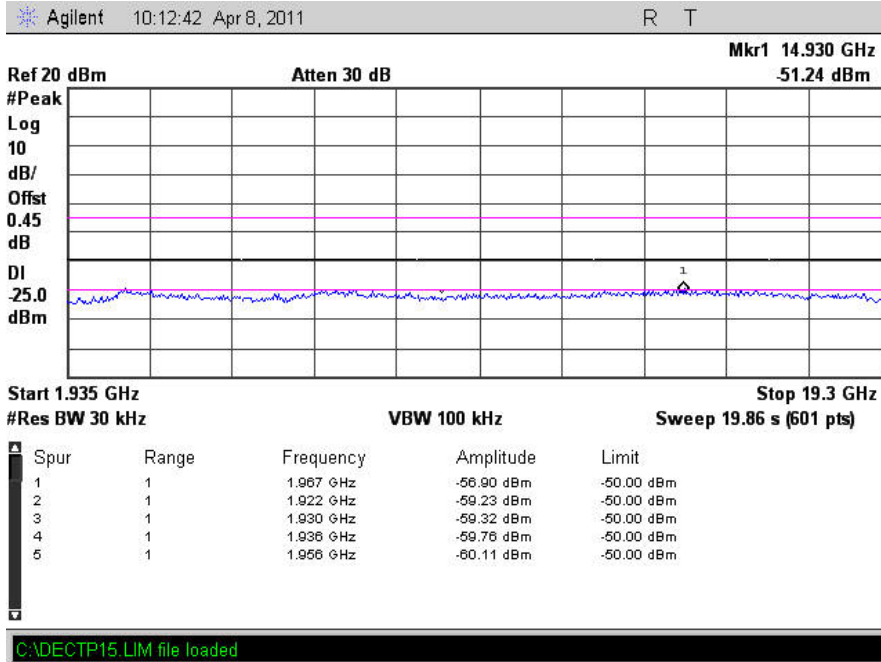

6.5.12 High Channel Out of Band 30 MHz – 1.915 GHz

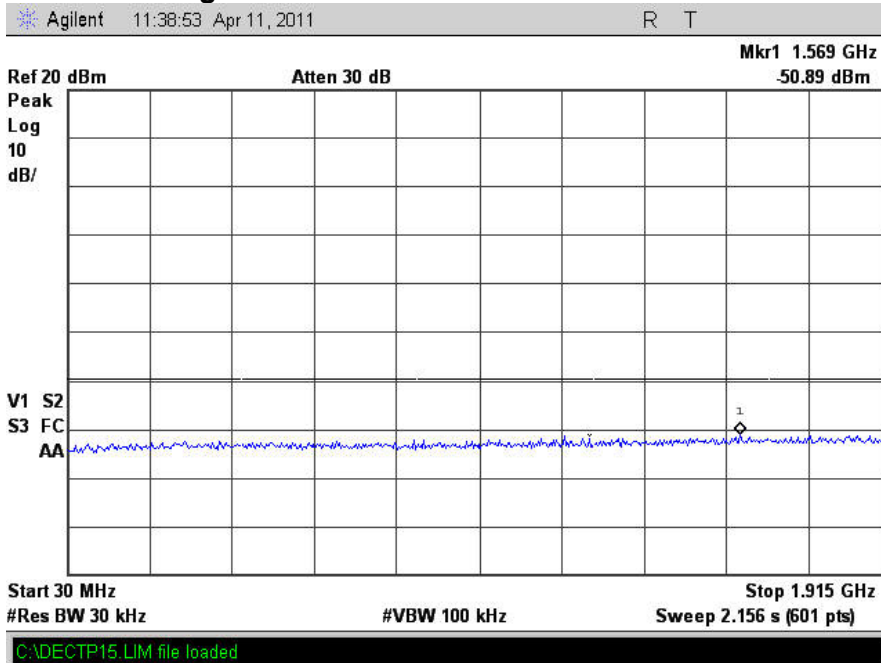

6. Measurement Data (continued)

6.5 Spurious Emissions at the antenna terminals (15.323 (d), RSS-213 6.7.1) (cont)

6.5.13 High Channel Out of Band 1.915 – 1.920 GHz

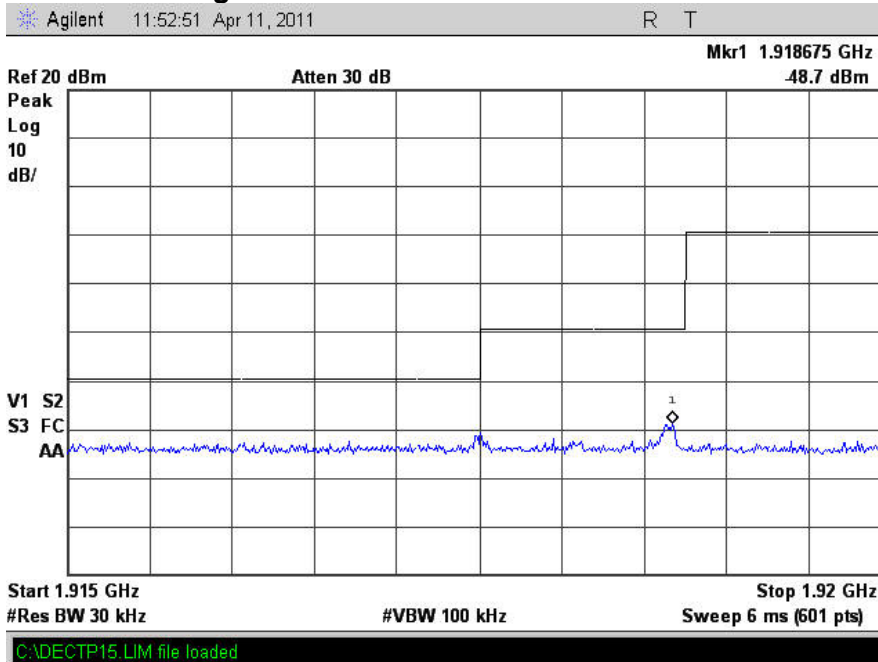

6.5.14 High Channel Out of Band 1.930 – 1.935 GHz

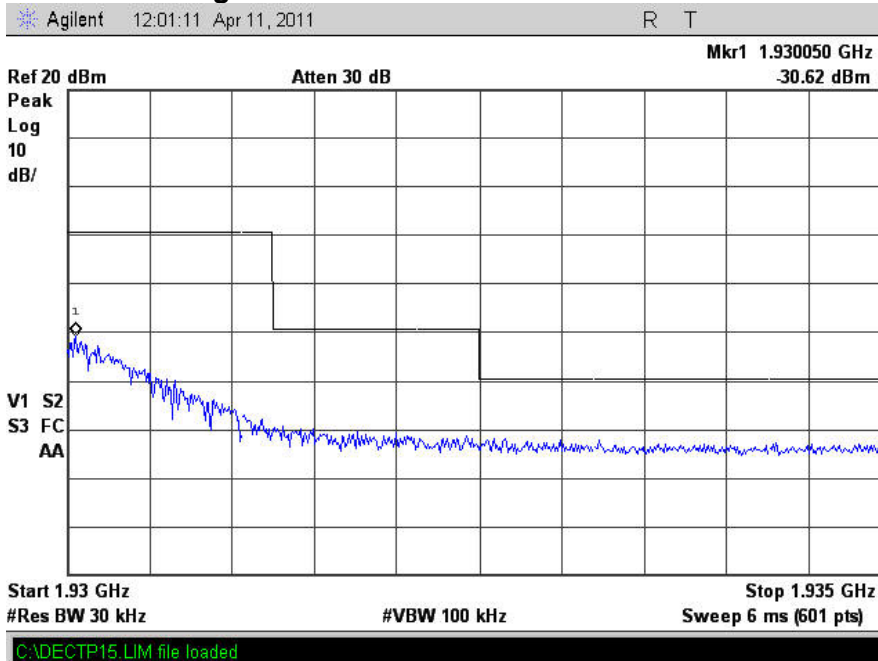

6. Measurement Data (continued)

6.5 Spurious Emissions at the antenna terminals (15.323 (d), RSS-213 6.7.1) (cont)

6.5.15 High Channel Out of Band 1.935 – 19.3 GHz

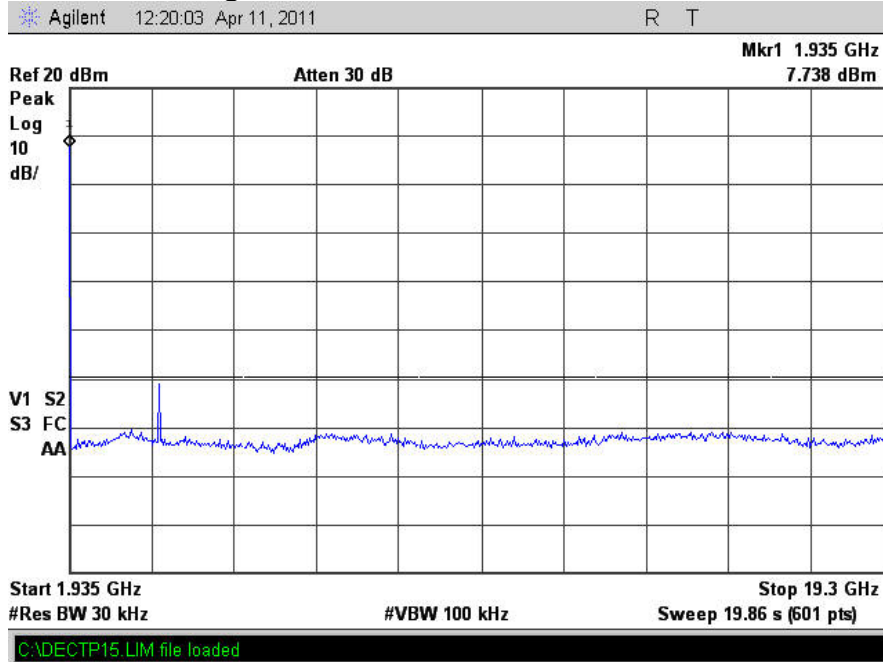

6. Measurement Data (continued)

6.5 Spurious Emissions for integral antennas (15.323 (d), 15.209, RSS-213 6.7.1) (cont)

Low Channel

Frequency (MHz)	Amplitude (dBµV/m)		Peak Limit	Peak Margin (dB)	Average Limit	Average Margin (dB)	Ant Pol	Ant Ht	TT Pos	Result
	Peak	Avg					H/V	cm	Deg	
3843	64.63	39.08	74	-9.37	54	-14.92	H	104	294	Compliant
5765	52.50	36.81	74	-21.50	54	-17.19	H	102	118	Compliant
7686	50.45	38.00	74	-23.55	54	-16.00	Noise Floor			Compliant
9608	52.88	40.64	74	-21.12	54	-13.36	Noise Floor			Compliant
11529	55.69	43.09	74	-18.31	54	-10.91	Noise Floor			Compliant
13451	58.97	45.96	74	-15.03	54	-8.04	Noise Floor			Compliant
15372	59.95	47.04	74	-14.05	54	-6.96	Noise Floor			Compliant
17294	54.63	42.36	74	-19.37	54	-11.64	Noise Floor - 1 Meter			Compliant
19215	53.90	41.70	74	-20.10	54	-12.30	Noise Floor			Compliant

Mid Channel

Frequency (MHz)	Amplitude (dBµV/m)		Peak Limit	Peak Margin (dB)	Average Limit	Average Margin (dB)	Ant Pol	Ant Ht	TT Pos	Result
	Peak	Avg					H/V	cm	Deg	
3850	62.78	38.30	74	-11.22	54	-15.70	H	107	317	Compliant
5775	51.35	36.46	74	-22.65	54	-17.54	H	107	146	Compliant
7700	50.37	37.94	74	-23.63	54	-16.06	Noise Floor			Compliant
9625	53.50	40.47	74	-20.50	54	-13.53	Noise Floor			Compliant
11550	55.87	42.98	74	-18.13	54	-11.02	Noise Floor			Compliant
13475	58.51	45.99	74	-15.49	54	-8.01	Noise Floor			Compliant
15400	59.25	46.74	74	-14.75	54	-7.26	Noise Floor			Compliant
17325	55.79	43.12	74	-18.21	54	-10.88	Noise Floor - 1 Meter			Compliant
19250	54.53	42.20	74	-19.47	54	-11.80	Noise Floor			Compliant

High Channel

Frequency (MHz)	Amplitude (dBµV/m)		Peak Limit	Peak Margin (dB)	Average Limit	Average Margin (dB)	Ant Pol	Ant Ht	TT Pos	Result
	Peak	Avg					H/V	cm	Deg	
3857	64.76	39.38	74	-9.24	54	-14.62	H	102	0	Compliant
5785	53.87	36.90	74	-20.13	54	-17.10	H	138	110	Compliant
7714	55.80	40.00	74	-18.20	54	-14.00	H	206	143	Compliant
9642	53.96	40.76	74	-20.04	54	-13.24	Noise Floor			Compliant
11571	55.65	43.08	74	-18.35	54	-10.92	Noise Floor			Compliant
13499	58.76	46.20	74	-15.24	54	-7.80	Noise Floor			Compliant
15428	59.07	46.66	74	-14.93	54	-7.34	Noise Floor			Compliant
17356	55.95	43.40	74	-18.05	54	-10.60	Noise Floor - 1 Meter			Compliant
19284	54.57	42.01	74	-19.43	54	-11.99	Noise Floor			Compliant

¹ Correction factors are included in measurement values

6. Measurement Data (continued)

6.5 Spurious Emissions for integral antennas (15.323 (d), 15.209, RSS-213 6.7.1) (cont)

Low Channel

Frequency (MHz)	Amplitude (dBµV/m)		Peak Limit	Peak Margin (dB)	Average Limit	Average Margin (dB)	Ant Pol	Ant Ht	TT Pos	Result
	Peak	Avg					H/V	cm	Deg	
3843	64.92	39.02	74	-9.08	54	-14.98	V	103	332	Compliant
5765	55.20	37.32	74	-18.80	54	-16.68	V	182	151	Compliant
7686	58.03	40.52	74	-15.97	54	-13.48	V	103	86	Compliant
9608	59.91	43.07	74	-14.09	54	-10.93	V	180	265	Compliant
11529	61.55	45.11	74	-12.45	54	-8.89	V	207	324	Compliant
13451	58.97	45.96	74	-15.03	54	-8.04	Noise Floor			Compliant
15372	59.95	47.04	74	-14.05	54	-6.96	Noise Floor			Compliant
17294	54.63	42.36	74	-19.37	54	-11.64	Noise Floor - 1 Meter			Compliant
19215	53.90	41.70	74	-20.10	54	-12.30	Noise Floor			Compliant

Mid Channel

Frequency (MHz)	Amplitude (dBµV/m)		Peak Limit	Peak Margin (dB)	Average Limit	Average Margin (dB)	Ant Pol	Ant Ht	TT Pos	Result
	Peak	Avg					H/V	cm	Deg	
3850	65.10	39.61	74	-8.90	54	-14.39	V	106	330	Compliant
5775	52.52	36.79	74	-21.48	54	-17.21	V	199	271	Compliant
7700	57.53	40.63	74	-16.47	54	-13.37	V	120	280	Compliant
9625	59.20	42.74	74	-14.80	54	-11.26	V	124	263	Compliant
11550	58.21	44.45	74	-15.79	54	-9.55	V	172	324	Compliant
13475	58.51	45.99	74	-15.49	54	-8.01	Noise Floor			Compliant
15400	59.25	46.74	74	-14.75	54	-7.26	Noise Floor			Compliant
17325	55.79	43.12	74	-18.21	54	-10.88	Noise Floor - 1 Meter			Compliant
19250	54.53	42.20	74	-19.47	54	-11.80	Noise Floor			Compliant

High Channel

Frequency (MHz)	Amplitude (dBµV/m)		Peak Limit	Peak Margin (dB)	Average Limit	Average Margin (dB)	Ant Pol	Ant Ht	TT Pos	Result
	Peak	Avg					H/V	cm	Deg	
3857	65.13	39.83	74	-8.87	54	-14.17	V	100	345	Compliant
5785	53.47	37.00	74	-20.53	54	-17.00	V	215	154	Compliant
7714	58.77	40.74	74	-15.23	54	-13.26	V	131	281	Compliant
9642	61.10	43.48	74	-12.90	54	-10.52	V	157	255	Compliant
11571	60.43	45.11	74	-13.57	54	-8.89	V	157	227	Compliant
13499	58.76	46.20	74	-15.24	54	-7.80	Noise Floor			Compliant
15428	59.07	46.66	74	-14.93	54	-7.34	Noise Floor			Compliant
17356	55.95	43.40	74	-18.05	54	-10.60	Noise Floor - 1 Meter			Compliant
19284	54.57	42.01	74	-19.43	54	-11.99	Noise Floor			Compliant

¹ Correction factors are included in measurement values

6. Measurement Data

6.6. Power Spectral Density (15.319 (d)), RSS-213 Sec 6.6

Requirement: FCC: Power spectral density shall not exceed 3 milliwatts in any 3 kHz bandwidth as measured with a spectrum analyzer having a resolution bandwidth of 3 kHz.

IC: The peak-hold power spectral density shall not exceed 12 milliwatts per any 3 kHz bandwidth.

As an alternative to the peak-hold power spectral density, the time-averaged power spectral density may be measured and it shall not exceed 3 milliwatts per any 3 kHz bandwidth.

Channel	Channel Frequency	Actual Measured Frequency	Power Spectral Density	Limit	Limit	Result
	MHz	MHz	dBm / 3kHz	dBm / 3kHz	mW / 3kHz	
TX4	1921.536	1921.519	-21.57	4.77	3.00	Compliant
TX2	1924.992	1924.909	-22.57	4.77	3.00	Compliant
TX0	1928.448	1928.215	-21.74	4.77	3.00	Compliant

6.6.1 Low Channel PSD

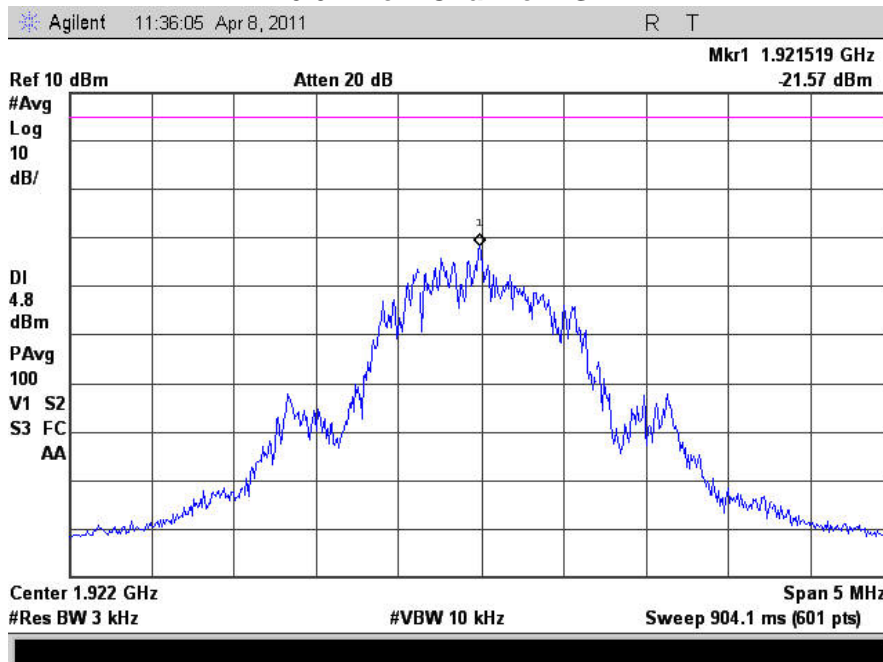

6. Measurement Data

6.6. Power Spectral Density (15.319 (d)), RSS-213 Sec 6.6 (cont)

6.6.2 Mid Channel PSD



6.6.3 High Channel PSD



6. Measurement Data

6.7. Regulatory Limit: FCC Part 15.315, 15.207, IC RSS-213 6.3, RSS-GEN

Frequency Range (MHz)	Limits (dBµV)	
	Quasi-Peak	Average
0.15 to 0.50	66 to 56*	56 to 46*
0.50 to 5.0	56	46
5.0 to 30.0	60	50

* Decreases with the logarithm of the frequency.

6.7.1. Measurement Equipment Used to Perform Test

Device	Manufacturer	Model No.	Serial No.	Cal Due
LISN	EMCO	3825/2	9109-1860	7/5/2012
EMI Receiver	Hewlett Packard	8546A	3330A00115	10/28/2011

6.7.2. Measurement & Equipment Setup

Test Date: Mar. 15th 2011 – Mar 31th, 2011
 Test Engineer: Brian Breault
 Site Temperature (°C): 21.6
 Relative Humidity (%RH): 35
 Frequency Range: 0.15 MHz to 30 MHz
 EMI Receiver IF Bandwidth: 9 kHz
 EMI Receiver Avg Bandwidth: 30 kHz
 Detector Functions: Peak, Quasi-Peak & Average

6.7.3. Test Procedure

Test measurements were made in accordance with ANSI C63.4-2003, Standard Methods of Measurement of Radio Noise Emissions from Low-Voltage Electrical and Electronics Equipment in the Range of 9 kHz to 40 GHz.

Note: AC conducted emissions were performed using a DC power supply. Typically the device will be battery powered.

6. Measurement Data

6.7.4. 120 Volts, 60 Hz Phase

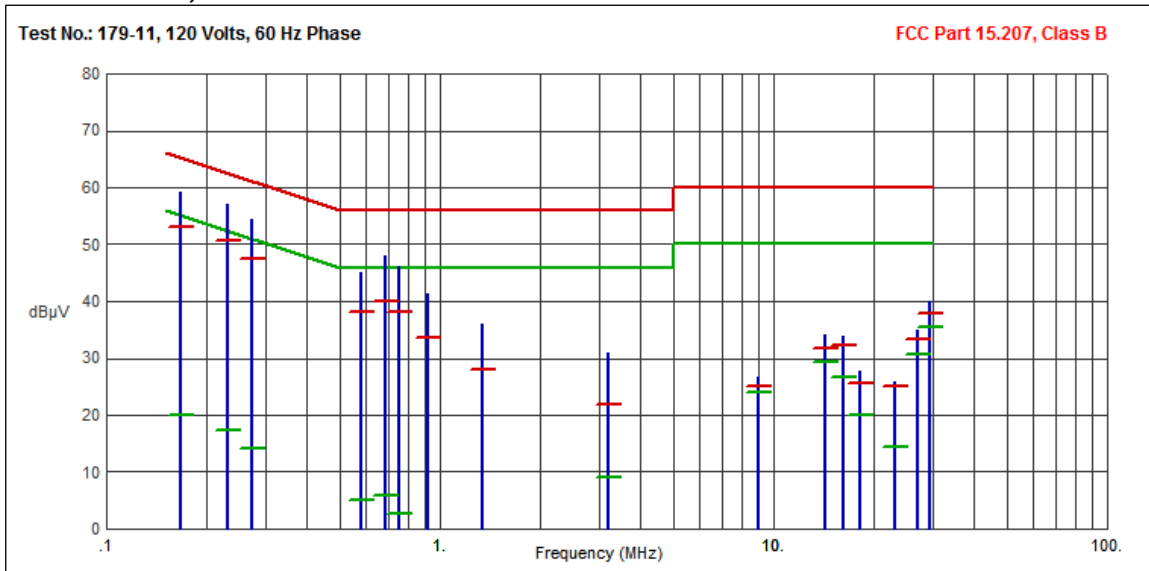

Frequency (MHz)	Pk Amp (dBµV)	QP Amp (dBµV)	QP Limit (dBµV)	QP Margin (dB)	Avg Amp (dBµV)	Avg Limit (dBµV)	Avg Margin (dB)	Comments
.1669	59.30	53.16	65.11	-11.95	19.93	55.11	-35.18	
.2301	57.11	50.65	62.45	-11.80	17.34	52.45	-35.11	
.2729	54.36	47.53	61.03	-13.50	14.16	51.03	-36.87	
.5776	45.00	38.20	56.00	-17.80	5.14	46.00	-40.86	
.6869	47.88	40.05	56.00	-15.95	5.79	46.00	-40.21	
.7521	46.04	38.19	56.00	-17.81	2.55	46.00	-43.45	
.9202	41.33	33.51	56.00	-22.49	-1.57	46.00	-47.57	
1.3465	35.88	28.08	56.00	-27.92	-5.54	46.00	-51.54	
3.1819	30.89	21.77	56.00	-34.23	9.10	46.00	-36.90	
9.0011	26.64	25.18	60.00	-34.82	23.87	50.00	-26.13	
14.2140	34.00	31.76	60.00	-28.24	29.45	50.00	-20.55	
16.1676	33.78	32.28	60.00	-27.72	26.55	50.00	-23.45	
18.2445	27.68	25.60	60.00	-34.40	20.11	50.00	-29.89	
23.1311	25.95	24.95	60.00	-35.05	14.42	50.00	-35.58	
27.1613	34.98	33.22	60.00	-26.78	30.63	50.00	-19.37	
29.2371	39.91	37.96	60.00	-22.04	35.40	50.00	-14.60	

6. Measurement Data

6.7.5. 120 Volts, 60 Hz Neutral

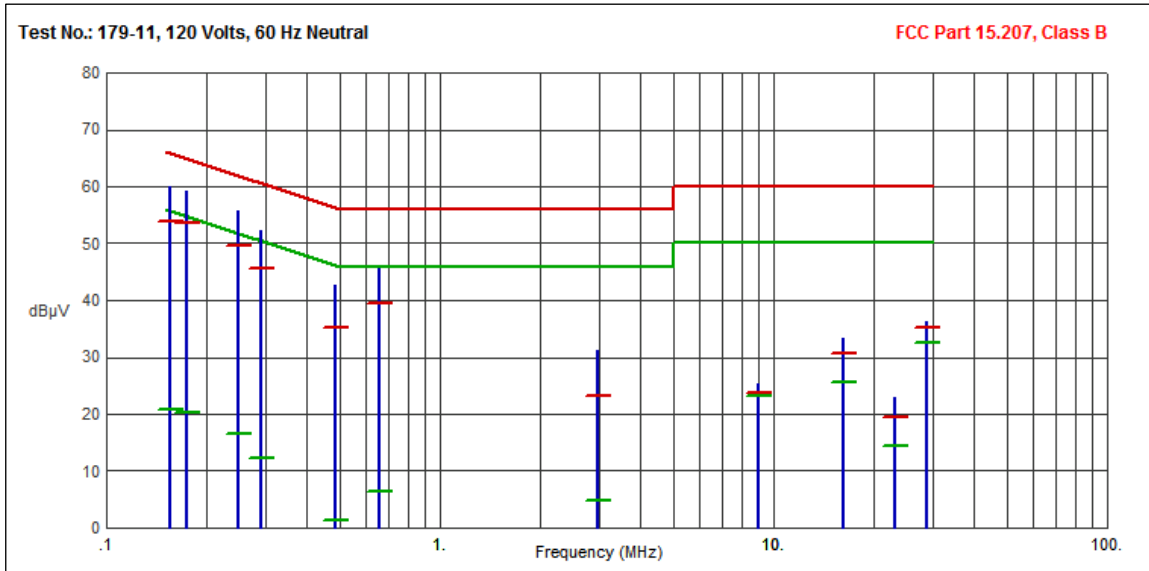

Frequency (MHz)	Pk Amp (dBµV)	QP Amp (dBµV)	QP Limit (dBµV)	QP Margin (dB)	Avg Amp (dBµV)	Avg Limit (dBµV)	Avg Margin (dB)	Comments
.1560	59.88	53.91	65.67	-11.76	20.80	55.67	-34.87	
.1743	59.28	53.48	64.75	-11.27	20.34	54.75	-34.41	
.2482	55.85	49.68	61.82	-12.14	16.45	51.82	-35.37	
.2901	52.35	45.61	60.52	-14.91	12.31	50.52	-38.21	
.4849	42.79	35.12	56.25	-21.13	1.46	46.25	-44.79	
.6568	45.69	39.45	56.00	-16.55	6.34	46.00	-39.66	
2.9762	31.30	23.09	56.00	-32.91	4.70	46.00	-41.30	
9.0010	25.28	23.70	60.00	-36.30	23.07	50.00	-26.93	
16.2281	33.40	30.78	60.00	-29.22	25.65	50.00	-24.35	
23.1272	22.83	19.38	60.00	-40.62	14.46	50.00	-35.54	
28.6873	36.28	35.28	60.00	-24.72	32.57	50.00	-17.43	

6. Measurement Data (continued)

6.8 Frequency Stability (15.313 (f)), IC RSS-213 6.2)

Requirement: The frequency stability of the carrier frequency of the intentional radiator shall be maintained within 10 ppm over 1 hour or the interval between channel access monitoring, whichever is shorter. This translates to a frequency drift of 19.2 kHz for a 1920 MHz carrier.

The frequency stability shall be maintained over a temperature variation of -20° to +50 °C at normal supply voltage, and over a variation in the primary supply voltage of 85 percent to 115 percent of the rated supply voltage at a temperature of 20 °C.

Channel	Channel Frequency	Voltage	Temperature	Measured Frequency Offset	Limit (+/-)	Limit (+/-)	Result
	MHz	VDC	Degrees C	kHz	kHz	ppm	
TX0	1928.448	5.00	20	1.0	19.2	10.0	Compliant
TX0	1928.448	4.25	20	2.0	19.2	10.0	Compliant
TX0	1928.448	5.75	20	2.0	19.2	10.0	Compliant
TX0	1928.448	5.00	-20	2.0	19.2	10.0	Compliant
TX0	1928.448	5.00	+50	2.0	19.2	10.0	Compliant

6.8.1 Timing 5 VDC, 20 degrees C

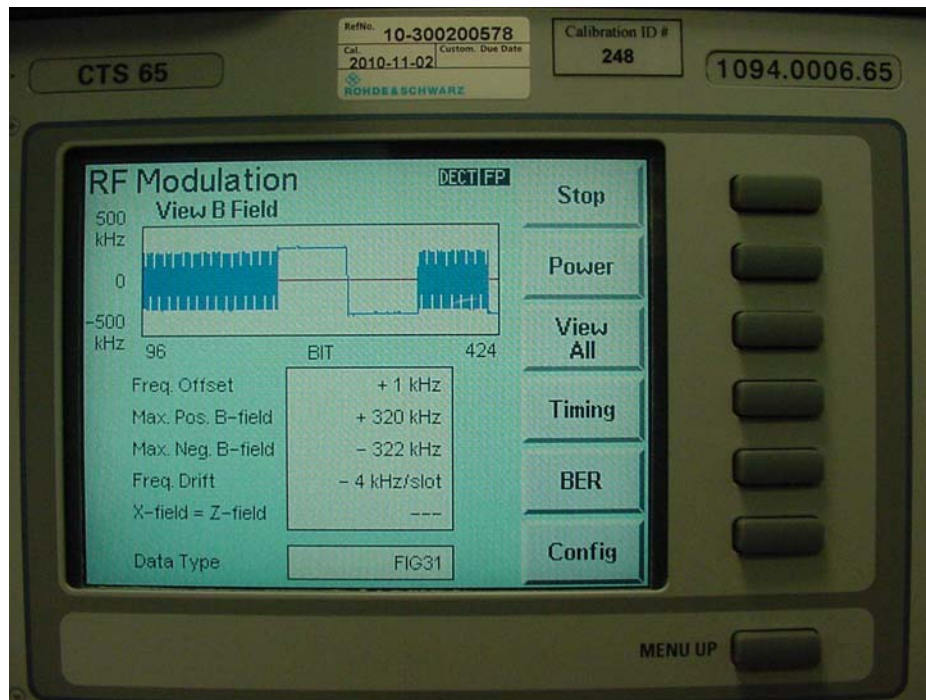

6. Measurement Data (continued)

6.9 Receiver Spurious Emissions (RSS 213 6.8)

6.9.1. Regulatory Limit: IC RSS-GEN, Class B, Quasi-Peak

Frequency Range (MHz)	Distance (Meters)	Limit (dBµV/m)
25 to 30	3	69.5
30 to 88	3	40.0
88 to 216	3	43.5
216 to 960	3	46.0
960 to 1000	3	54.0

6.9.2. Measurement Equipment Used to Perform Test

Device	Manufacturer	Model No.	Serial No.	Cal Due
Loop Antenna	EMCO	6502	2197	7/22/2012
Biconilog Antenna	Com-Power	AC220	25509	8/30/2011
EMI Receiver	Hewlett Packard	8546A	3330A00115	10/28/2011

6.9.3. Measurement & Equipment Setup

Test Date: 02/09/2011
 Test Engineer: Cody Merry
 Site Temperature (°C): 25
 Relative Humidity (%RH): 33
 Frequency Range: 30 MHz to 1 GHz
 Measurement Distance: 3 Meters
 EMI Receiver IF Bandwidth: 120 kHz
 EMI Receiver Avg Bandwidth: 300 kHz
 Detector Functions: Peak and Quasi-Peak.
 Antenna Height: 1 to 4 meters

6.9.4. Test Procedure

Test measurements were made in accordance with ANSI C63.4-2003, Standard Methods of Measurement of Radio Noise Emissions from Low-Voltage Electrical and Electronics Equipment in the Range of 9 kHz to 40 GHz.

6. Measurement Data (continued)

6.9. Radiated Emissions (25 MHz to 30 MHz) Test Results

6.9.5. Antenna Parallel to the Device Under Test

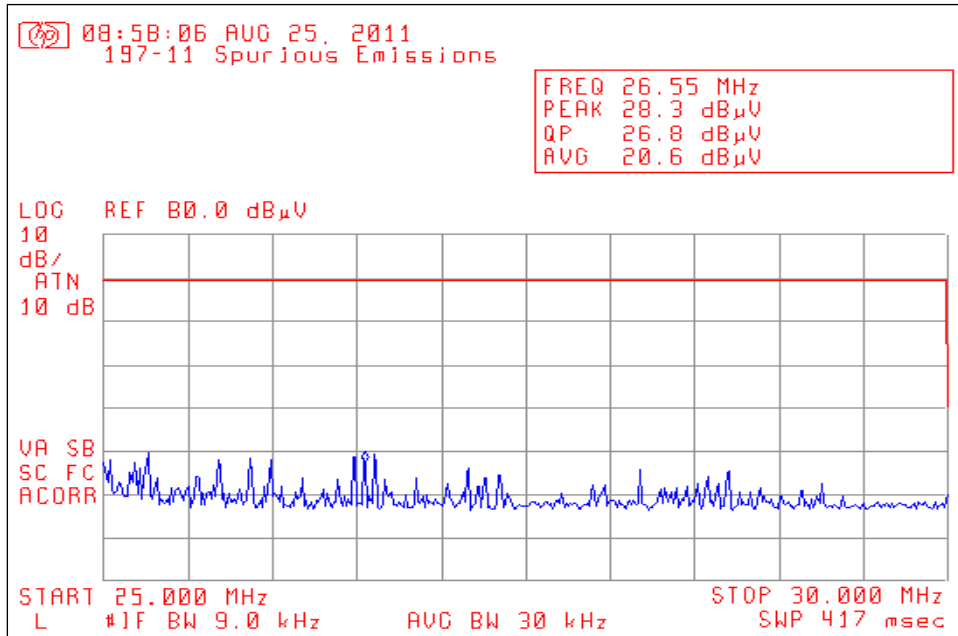

6.9.6. Antenna Perpendicular to the Device Under Test

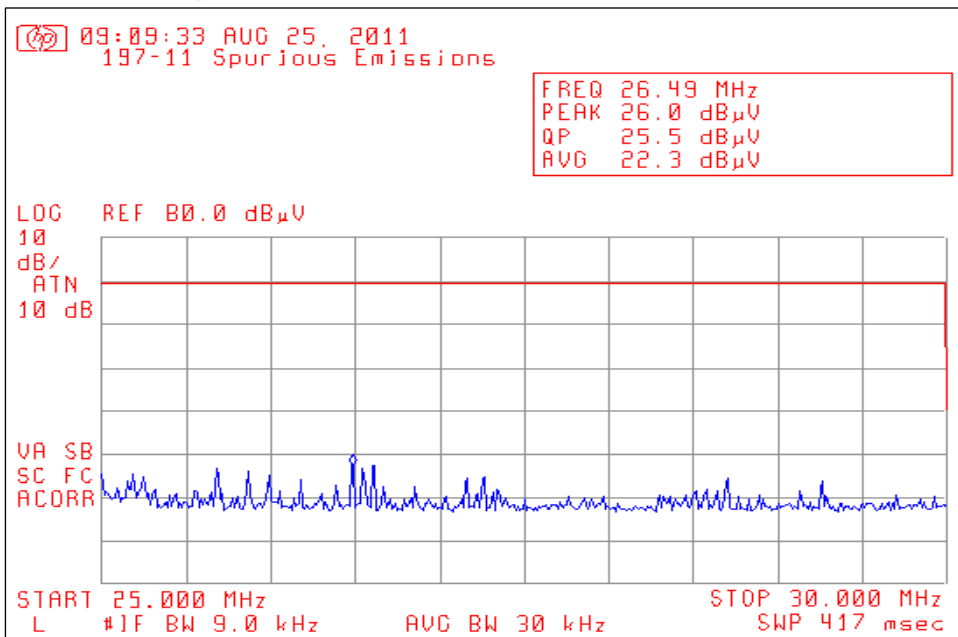

6. Measurement Data (continued)

6.9. Radiated Emissions (30 MHz to 1 GHz) Test Results

6.9.7. Horizontal Polarity

Test No.: 179.11, Radiated Emissions - Horizontal Polarity

FCC Part 15.209

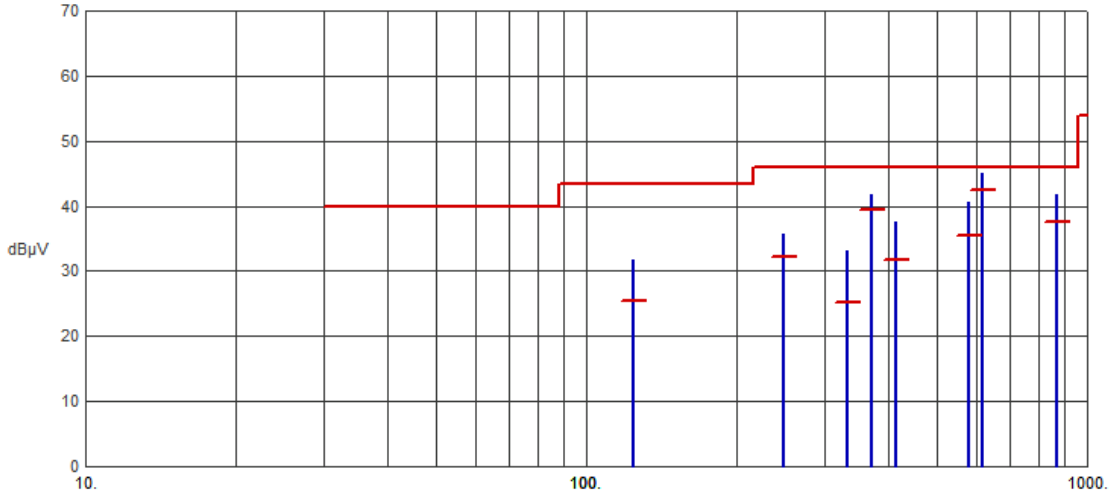

Frequency (MHz)	Pk Amp (dBµV/m)	QP Amp (dBµV/m)	QP Limit (dBµV/m)	Margin (dB)	Ant Ht (cm)	Table (Deg)	Comments
123.9874	31.74	25.42	43.50	-18.08	N/A	N/A	
248.0062	35.71	32.22	46.00	-13.78	N/A	N/A	
331.7923	33.17	25.24	46.00	-20.76	N/A	N/A	
372.0214	41.67	39.41	46.00	-6.59	N/A	N/A	
414.2886	37.67	31.85	46.00	-14.15	N/A	N/A	
581.3001	40.49	35.37	46.00	-10.63	N/A	N/A	
620.0233	44.93	42.46	46.00	-3.54	N/A	N/A	
868.0556	41.69	37.65	46.00	-8.35	N/A	N/A	

6. Measurement Data (continued)

6.9 Radiated Emissions (30 MHz to 1 GHz) Test Results (continued)

6.9.8. Vertical Polarity

Test No.: 179.11, Radiated Emissions - Vertical Polarity

FCC Part 15.209

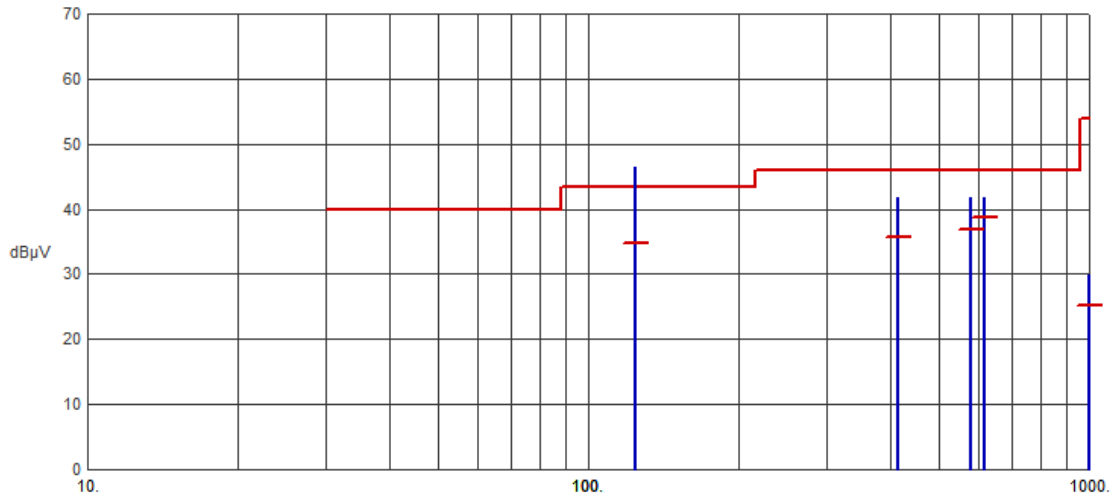

Frequency (MHz)	Pk Amp (dBµV/m)	QP Amp (dBµV/m)	QP Limit (dBµV/m)	Margin (dB)	Ant Ht (cm)	Table (Deg)	Comments
123.9984	46.32	34.84	43.50	-8.66	N/A	N/A	
415.2642	41.82	35.80	46.00	-10.20	N/A	N/A	
579.8525	41.82	36.91	46.00	-9.09	N/A	N/A	
620.0114	41.72	38.62	46.00	-7.38	N/A	N/A	
999.5948	29.80	25.17	54.00	-28.83	N/A	N/A	

6. Measurement Data (continued)

6.10 Specific Requirements to UPCS Devices (15.323 (e), RSS-213 4.3.4 (c))

Requirement: The frame period (a set of consecutive time slots in which the position of each time slot can be identified by reference to a synchronizing source) of an intentional radiator operating in this sub-band shall be 20 milliseconds/X where X is a positive whole number.

Each device that implements time division for the purpose of maintaining a duplex connection on a given frequency carrier shall maintain a frame repetition rate with a frequency stability of at least 50 parts per millions (ppm). Each device which further divides access in time in order to support multiple communication links on a given frequency carrier shall maintain a frame repetition rate with a frequency stability of at least 10 ppm.

The jitter (time-related, abrupt, spurious variations in the duration of the frame interval) introduced at the two ends of such a communication link shall not exceed 25 microseconds for any two consecutive transmissions.

Frame Repetition Stability (ppm)	Limit (ppm)	Result
0.66	10.00	Compliant

Maximum Positive Jitter (µS)	Maximum Negative Jitter (µS)	Frame Period (mS)	Limit	Result
0.00	-0.00	10.000	25 µS	Compliant

6. Measurement Data (continued)

6.10 Specific Requirements to UPCS Devices (15.323 (e), RSS-213 4.3.4 (c)) (cont)

6.10.1 Time Accuracy & Maximum Jitter (cont)

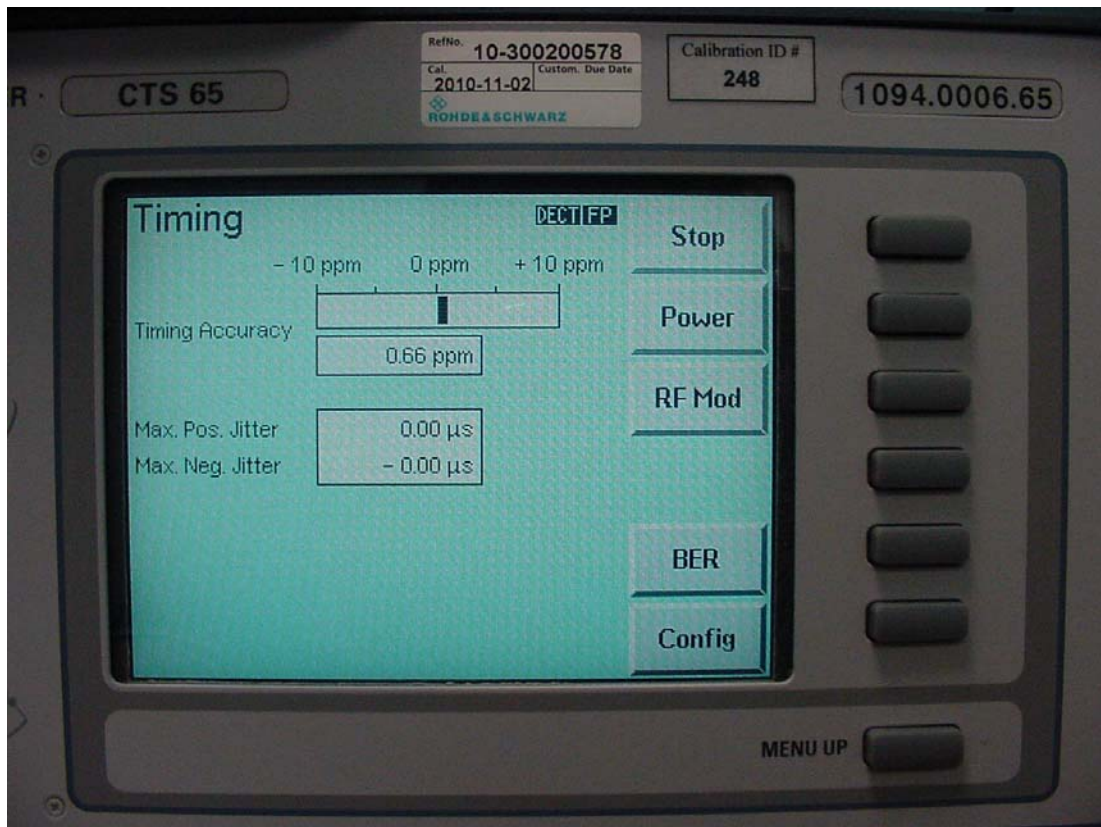

6. Measurement Data (continued)

6.10 Specific Requirements to UPCS Devices (15.323 (e), RSS-213 4.3.4) (cont)

6.10.2 Automatic Discontinuation of Transmission (15.319(f), RSS-213 4.3.4 (a))

Requirement: Devices shall automatically discontinue transmission in case of either absence of information to transmit or operational failure. This is not intended to preclude transmission of control and signaling information or use of repetitive codes used by certain digital technologies to complete frame or burst intervals.

Result: Compliant

Evaluation	Result
Test according to a)	Compliant
Assessment of manufacturer declaration	-- --

a) The tests are done after establishment of a connection to counterpart.

	Test case	Reaction of EUT	Result
1	Switch – off counterpart	B	Compliant
2	Hook-on by counterpart	--	--
3	Switch- off by EUT	A	Compliant
4	Hook -on on EUT side	--	--
5	Remove power from EUT	A	Compliant
6	Remove power from counterpart	B	Compliant

A – Connection break down, cease of transmit

B – Connection break down, EUT transmits signaling information

C – Connection break down, counterpart transmits signaling information

6. Measurement Data (continued)

6.10 Specific Requirements to UPCS Devices (cont)

6.10.3 Monitoring Time (15.323(c) (1), RSS-213 4.3.4 (b) (1))

Requirement: Devices must incorporate a mechanism for monitoring the time and spectrum windows that their transmission is intended to occupy. The following criteria must be met: Immediately prior to initiating a transmission, devices must monitor the combined time and spectrum window, which they intend to use, to verify if the channel is free, for at least 10 milliseconds for systems designed to use a 10 ms or shorter frame period, or at least 20 ms for systems designed to use a 20 ms frame period.

Pulse Width	Connection	
	FL	FU
50 μ S or 50 * SQRT (1.25/B) μ S	no	no
35 μ S or 35 * SQRT (1.25/B) μ S	no	no

6.10.3.1 Measurement of Frame Period

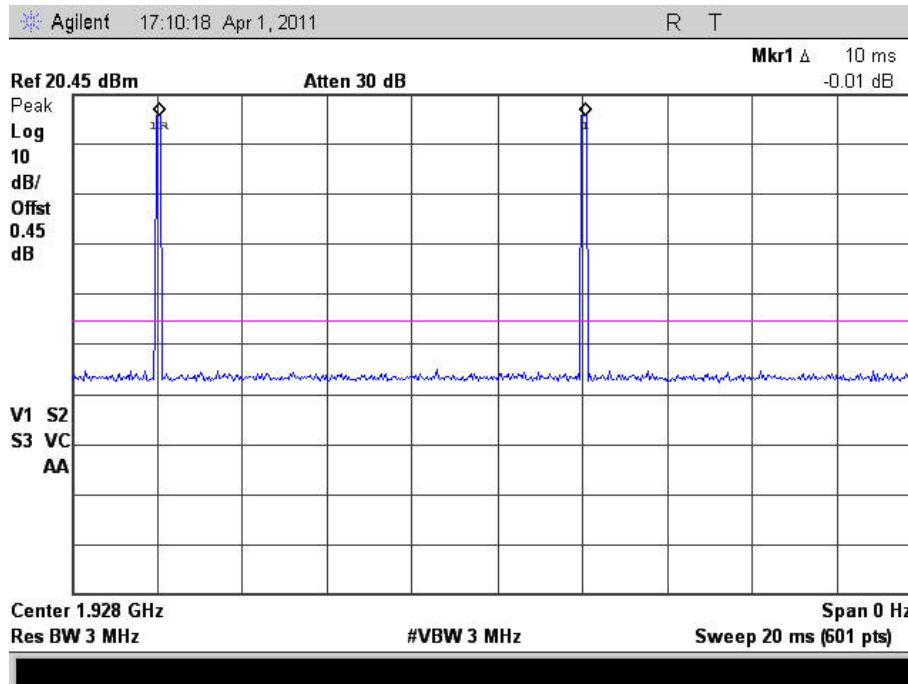

Result: Compliant

6. Measurement Data (continued)

6.10 Specific Requirements to UPCS Devices (cont)

6.10.3 Monitoring Time (15.323(c) (1), RSS-213 4.3.4 (b) (1) (cont)

6.10.3.2 Measurement of Nominal Burst Length (Frame Width)

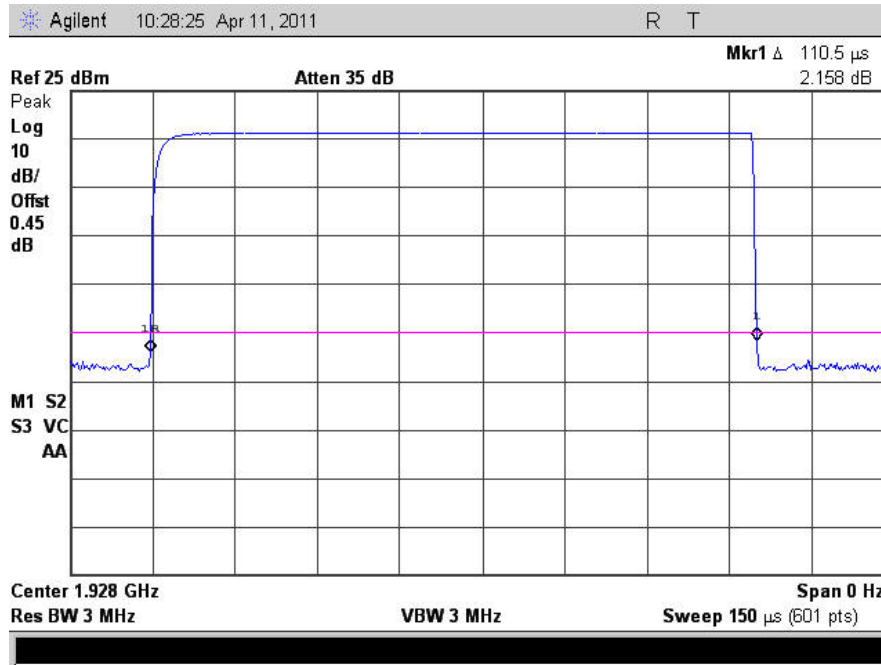

Result: Compliant

6.10.4 Lower Monitoring Threshold (15.323(c) (2), RSS-213 4.3.4 (b) (2)

Requirement: The monitoring threshold must not be more than 30 dB above the thermal noise power (KTB) of a bandwidth equivalent to the occupied bandwidth of the device.

For EUTs which support least interfered channel procedure (LIC), it is not necessary to measure the lower threshold under rule parts 15.323 (c) (2) and 4.3.4 (b) (2).

These are automatically met by the LIC procedure in clauses 15.323 (c) (5) and 4.3.4 (b) (5).

Result: Compliant, does not apply

6. Measurement Data (continued)

6.10 Specific Requirements to UPCS Devices (cont)

6.10.5 Maximum Transmit Period (15.323(c) (3), RSS-213 4.3.4 (b) (3))

Requirement: If no signal above the threshold level is detected, transmission may commence and continue with the same bandwidth in the monitored time and spectrum windows without further monitoring. Occupation of the same combined time and spectrum windows by a device or group of cooperating devices, continuously over a period of time longer than 8 hours is not permitted without repeating the access criteria.

Requirement	Time	Limit	Result
Maximum Transmission Time 8.2.2	< 8 Hours	8 Hours	Compliant

Result: Compliant

6.10.6 System Acknowledgement (15.323(c) (4), RSS-213 4.3.4 (b) (4))

Requirement: Once access to specific combined time and spectrum windows is obtained, an acknowledgement from a system participant must be received by the initiating transmitter within one second or transmission must cease. Periodic acknowledgements must be received at least every 30 seconds or transmission must cease. Channels used exclusively for control and signaling information may transmit continuously for 30 seconds without receiving an acknowledgement, at which time the access criteria must be repeated.

Connection acknowledgements are tested according to ANSI 63.17-2006 subclause 8.2.1. Unacknowledged transmission following sub clause 8.1.1. Access criteria test interval and 8.1.2 Access criteria functional test. subclause 8.1.3 Access criteria functional test is not applicable because option FCC 15.323 (c)(6) / RSS-213 4.3.4 (b)(6) is not implemented.

Requirement	Time	Limit	Result
Access Criteria test interval 8.1.1	28 s	<=30 secs	Compliant

Result: Compliant

6. Measurement Data (continued)

6.10 Specific Requirements to UPCS Devices (cont)

6.10.7 Least Interfered Channel (LIC) Selection (15.323(c) (5), RSS-213 4.3.4 (b) (5)

Requirement: If access to spectrum is not available as determined by the above, and a minimum of 40 duplex system access channels are defined for the system, the time and spectrum windows with a power level below a monitoring threshold of 50 dB above the thermal noise power determined for the occupied bandwidth may be accessed.

A device utilizing the provisions of this paragraph (5) must have monitored all access channels defined for its system within the last 10 seconds and must verify, within the 20 milliseconds (40 milliseconds for devices designed to use a 20 millisecond frame period) immediately preceding actual channel access, that the detected power of the selected time and spectrum windows is no higher than the previously detected value.

The power measurement resolution bandwidth for this comparison must be accurate to within 6 dB.

No device or group of cooperating devices located within 1 meter of each other shall during any frame period occupy more than 6 MHz of aggregate bandwidth, or alternatively, more than one third of the time and spectrum windows defined by the system.

Result: Compliant

Lower Threshold: $TL = 15 \log_{10} B - 184 + 30 - P$ (dBm)

Upper Threshold: $TU = 15 \log_{10} B - 184 + 50 - P$ (dBm)

B = Emission Bandwidth in Hz

P = Peak Transmit Power (dBm)

Calculated Thresholds:

	dBm
TL: Lower Threshold	-77.68
TU: Upper Threshold	-57.68

Limits:

Limits	
	$TLR < TL + UM = -77.68 + 6.0 = -71.68$ dBm
	$TUR < TU + UM = -57.68 + 6.0 = -51.68$ dBm

6. Measurement Data (continued)

6.10 Specific Requirements to UPCS Devices (cont)

6.10.7 (LIC) Selection (15.323(c) (5), RSS-213 4.3.4 (b) (5) (cont)

6.10.7.1 Plot Showing Channel Move Function

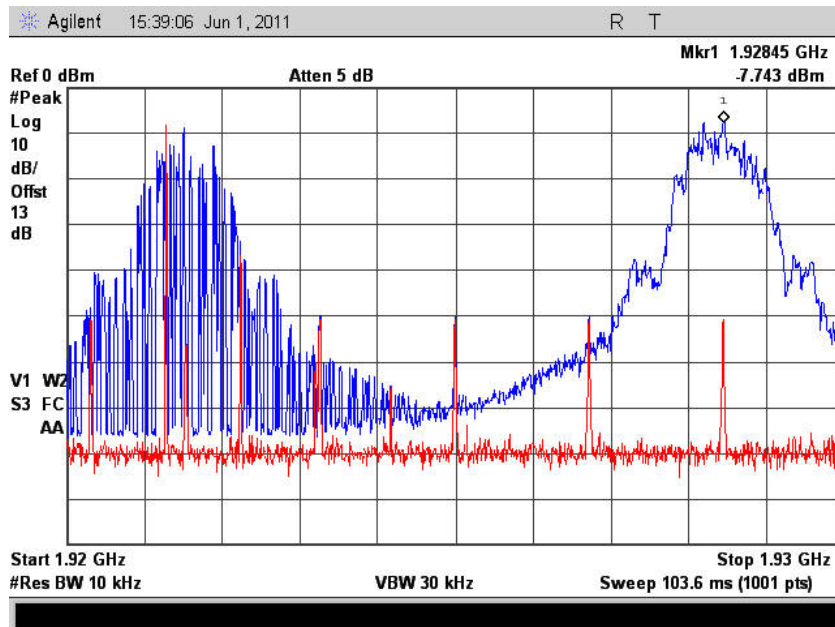

6.10.7.2 Channel Selection with TX2 - Mid Channel Low

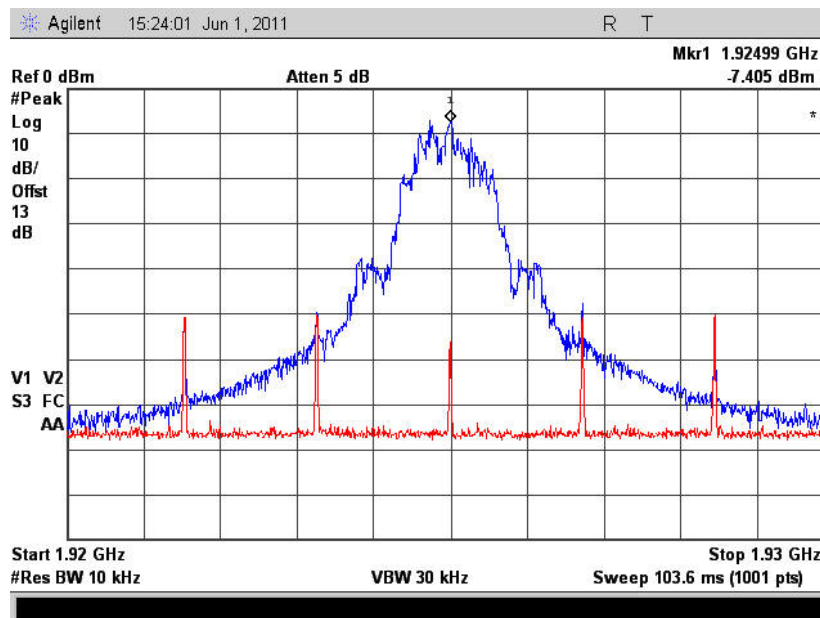

6. Measurement Data (continued)

6.10 Specific Requirements to UPCS Devices (cont)

6.10.7 (LIC) Selection (15.323(c) (5), RSS-213 4.3.4 (b) (5) (cont)

6.10.7.3 Channel Selection with Mid Channel Low, Low Channel Lower

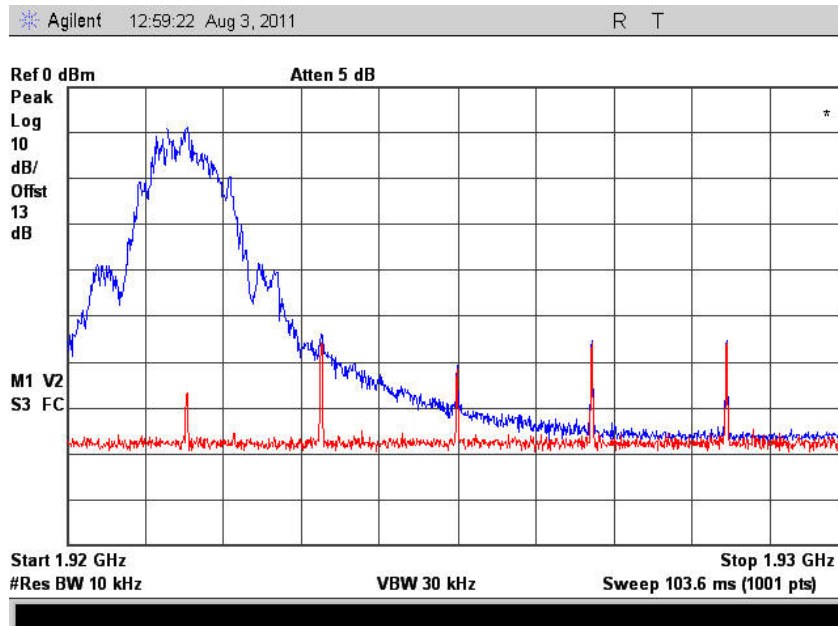

6.10.7.4 Channel Selection with TX1 Channel Low

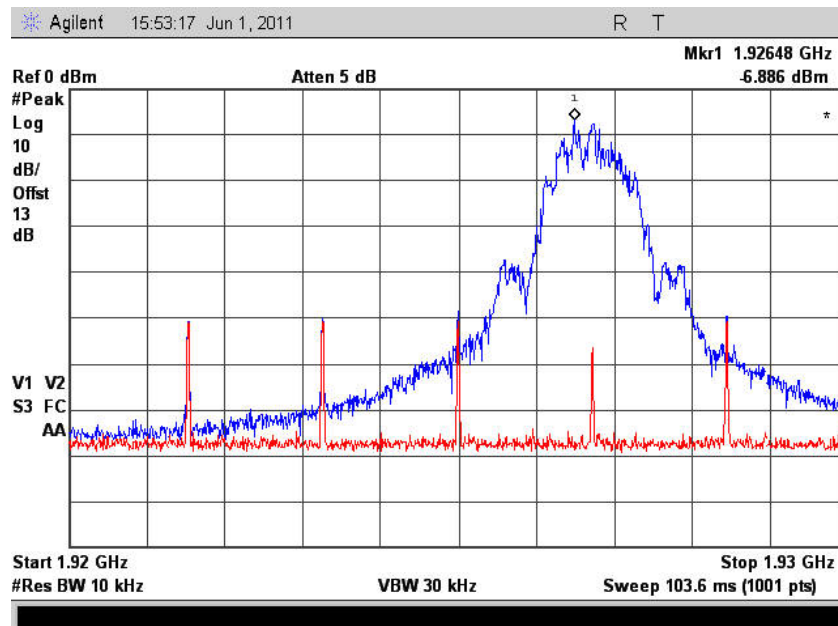

6. Measurement Data (continued)

6.10 Specific Requirements to UPCS Devices (cont)

6.10.7 (LIC) Selection (15.323(c) (5), RSS-213 4.3.4 (b) (5) (cont)

6.10.7.5 Channel Selection with TX3 Channel Low

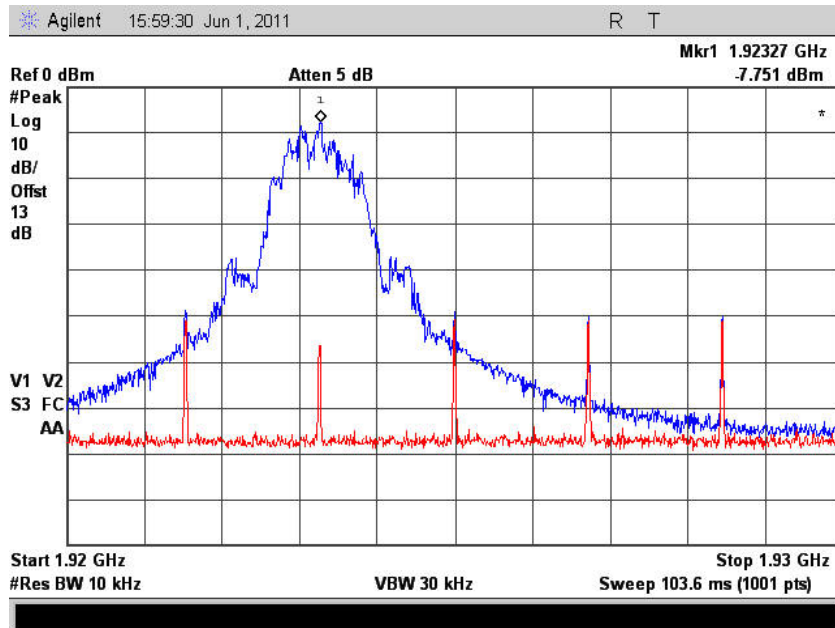

6.10.7.6 Channel Selection with TX0 Channel Low

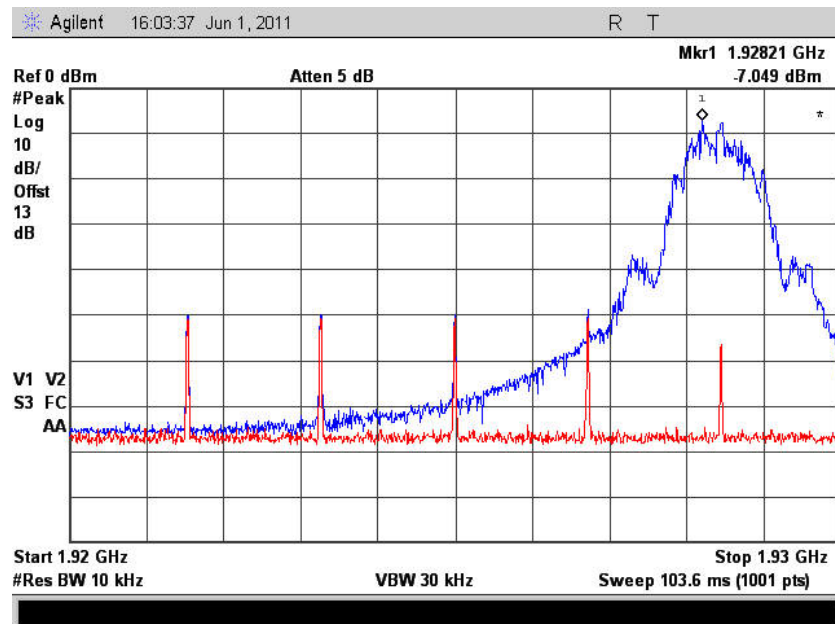

6. Measurement Data (continued)**6.10 Specific Requirements to UPCS Devices (cont)****6.10.8 Random waiting (15.323(c) (6), RSS-213 4.3.4 (b) (6))**

Requirement: If the selected combined time and spectrum windows are unavailable, the device may either monitor and select different windows or seek to use the same windows after waiting an amount of time, randomly chosen from a uniform random distribution between 10 and 150 milliseconds, commencing from the time when the channel becomes available.

Result: Compliant, this feature is not implemented in the EUT.

6.10.9 Monitoring Bandwidth (15.323(c) (7), RSS-213 4.3.4 (b) (7))

Requirement: The monitoring system bandwidth must be equal to or greater than the occupied bandwidth of the intended transmission.

Note: Testing of the monitoring system bandwidth is not required if the designed bandwidth from the manufacturer is available and given in the test report.

The monitor shall have a maximum reaction time less than $50\sqrt{1.25 / \text{occupied bandwidth in MHz}}$ microseconds for signals at the applicable threshold level but shall not be required to be less than 50 microseconds.

If a signal is detected that is 6 dB or more above the threshold level, the maximum reaction time shall be $35\sqrt{1.25 / \text{occupied bandwidth in MHz}}$ microseconds but shall not be required to be less than 35 microseconds.

Result: Compliant

6. Measurement Data (continued)**6.10 Specific Requirements to UPCS Devices (cont)****6.10.10 Monitoring Antenna (15.323(c) (8), RSS-213 4.3.4 (b) (8)**

Requirement: The monitoring system shall use the same antenna used for transmission, or an antenna that yields equivalent reception at that location.

Note: A monitoring antenna of the same model (and manufacturer) as the transmitting antenna is considered equivalent. An antenna not of the same model but of the same type (e.g. both are horn antennas of different manufacturers) is considered equivalent if the main beam antenna gains are within 3 dB of each other. Both antennas are to be installed to point at the same general coverage area.

Result: Compliant, the device uses the same antenna.

6.10.11 Monitoring Threshold Relaxation (15.323(c) (9), RSS-213 4.3.4 (b) (9)

Requirement: Devices that have a power output lower than the maximum permitted under this standard may increase their detection threshold by 1 dB for each 1 dB that the transmitter power is below the maximum permitted.

Result: Compliant, requirement is covered by LIC test in 15.323 (b)(5) / 4.3.4 (b)(5).

6.10.12 Duplex Connections (15.323(c) (10), RSS-213 4.3.4 (b) (10)

Requirement: A device initiating a communication (hereafter called an initiating device) may attempt to establish a duplex connection by monitoring both its intended transmit and receive time and spectrum windows. If both the intended transmit and receive time and spectrum windows meet the access criteria, then the initiating device can initiate a transmission in the intended transmit time and spectrum window. If the power detected by the responding device can be decoded as a duplex connection signal from the initiating device, then the responding device may immediately begin transmitting on the receive time and spectrum window monitored by the initiating device.

Result: Compliant, EUT does not support Duplex Connections.

6. Measurement Data (continued)**6.10 Specific Requirements to UPCS Devices (cont)****6.10.13 Alternative monitoring interval for co-located devices
(15.323(c) (11), RSS-213 4.3.4 (b) (11))**

Requirement: An initiating device that is prevented from monitoring during its intended transmit window due to monitoring system blocking from the transmissions of a co-located (within one meter) transmitter of the same system, may monitor the portions of the time and spectrum windows in which they intend to receive over a period of at least 10 milliseconds.

The monitored time and spectrum window must total at least 50 percent of the 10 millisecond frame interval and the monitored spectrum must be within 1.25 MHz of the centre frequency of channel(s) already occupied by that device or co-located co-operating devices.

If the access criteria is met for the intended receive time and spectrum window under the above conditions, then transmission in the intended transmit window by the initiating device may commence.

Result: Compliant, devices are not co-located within 1 meter.

6.10.14 Fair Access (15.323(c) (12), RSS-213 4.3.4 (b) (12))

Requirement: The provisions of Part 15.323 (c) (10) or (c) (11) and/or RSS-213 4.3.4 (b) (10) or (11) shall not be used to extend the range of spectrum occupied over space or time for the purpose of denying fair access to spectrum to other devices.

Result: Compliant, EUT does not operate in a mode that denies fair access.

6. Measurement Data (continued)

6.11. Public Exposure to Radio Frequency Energy Levels (1.1307 (b)(1))

RSS-GEN 5.5, RSS 102

6.11.1. MPE Power Density Table

Channel	MPE Distance (cm)	DUT Output Power (dBm)	DUT Antenna Gain (dBi)	Power Density		Limit (mW/cm ²)	Result
				(mW/cm ²)	(W/m ²)		
	(1)	(2)	(3)	(4)		(5)	
TX4	20	16.13	2.50	0.015	0.145	1	Compliant
TX2	20	16.23	2.50	0.015	0.149	1	Compliant
TX0	20	16.24	2.50	0.015	0.149	1	Compliant

$$PD = \frac{OP + AG}{(4 \times \pi \times d^2)}$$

PD = Power Density
 OP = DUT Output Power (dBm)
 AG = Antenna Gain (dBi)
 D = MPE Distance

- Reference CFR 2.1093(b): For purposes of this section, a portable device is defined as a transmitting device designed to be used so that the radiating structure(s) of the device is/are within 20 centimeters of the body of the user.
- Section 6.3 of this test report.
- Data supplied by the client.
- Power density is calculated from conducted power output measurement and antenna gain.
- Reference CFR 1.1310, Table 1: Limits for Maximum Permissible Exposure (MPE), Section (B): Limits for General Population/Uncontrolled Exposure.

RSS-102 Section 2.5, 2.5.1 & 2.5.2 Requirements:

2.5 - All transmitters are exempt from routine SAR and RF exposure evaluations provided that output power complies with the power levels of sections 2.5.1 or 2.5.2. If the equipment under test (EUT) meets the requirements of sections 2.5.1 or 2.5.2, applicants are only required to submit a properly signed declaration of compliance (see Annex C).

2.5.1 - SAR evaluation is required if the separation distance between the user and the radiating element of the device is less than or equal to 20 cm, except when the device operates as follows:

- above 2.2 GHz and up to 3 GHz inclusively, and with output power (i.e. the higher of the conducted or radiated (e.i.r.p.) source-based, time-averaged output power) that is less than or equal to 20 mW for general public use and 100 mW for controlled use

2.5.2 - RF exposure evaluation is required if the separation distance between the user and the device's radiating element is greater than 20 cm, except when the device operates as follows:

- at or above 1.5 GHz and the maximum e.i.r.p. of the device is equal to or less than 5 W.

7. Test Images

7.1. Radiated Emissions – Front



7. Test Images

7.2. Radiated Emissions – Rear



7. Test Images

7.3. Conducted Emissions (Rear)



7. Test Images

7.4. Extreme Temperature Conditions



8. Test Site Description

Compliance Worldwide is located at 357 Main Street in Sandown, New Hampshire. The test sites at Compliance Worldwide are used for conducted and radiated emissions testing in accordance with Federal Communications Commission (FCC) and Industry Canada standards. A description of the test sites is on file with the FCC (registration number **96392**) and Industry Canada (file number **IC 3023A-1**).

The radiated emissions test site is a 3 and 10 meter enclosed open area test site (OATS). Personnel, support equipment and test equipment are located in the basement beneath the OATS ground plane.

The conducted emissions site consists of a 10' x 9' ground plane with an 8' x 9' Vertical Plane that is bonded at the seams.

Both sites are designed to test products or systems 1.5 meter W x 1.5 meter L x 2.0 meter H, floor standing or table top.