

NOTES:

- 1. MATERIAL - ABS. PANTONE BLACK 7C.
- 2. FINISH - POLISHED SMOOTH CORE, EXTERNAL SURFACES TEXTURED PER MT-11010 UNLESS OTHERWISE SPECIFIED.
- 3. GATES TO BE REMOVED FLUSH OR BELOW ADJACENT SURFACE.
- 4. PARTING LINES MINIMIZED TO .05 MAX.

2 - ADD DRAFT AND NO DRAFT NOTES  
 3 - ADD SECTION C-C -- ADD 0.4 TO SNAP HEIGHT

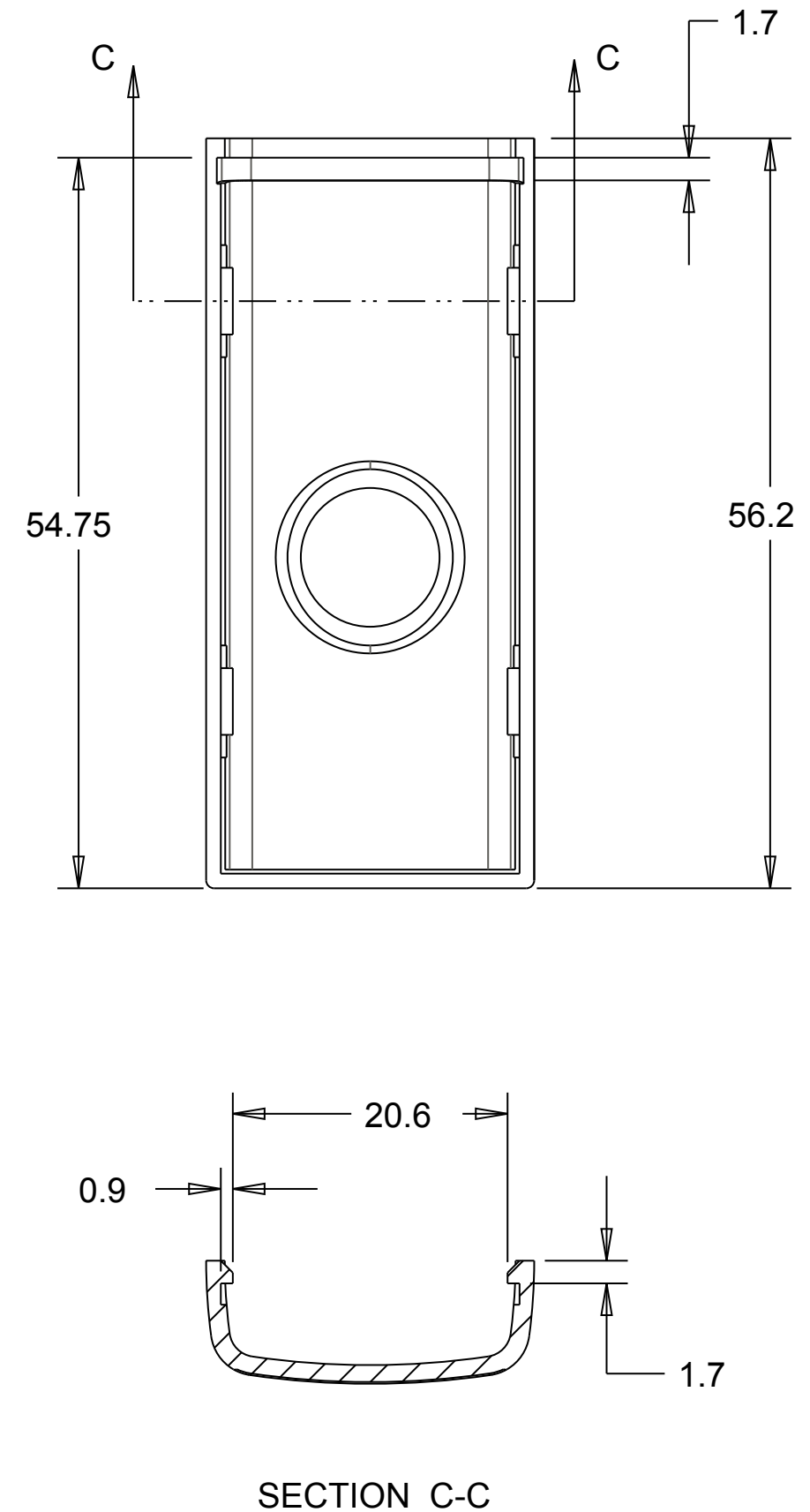
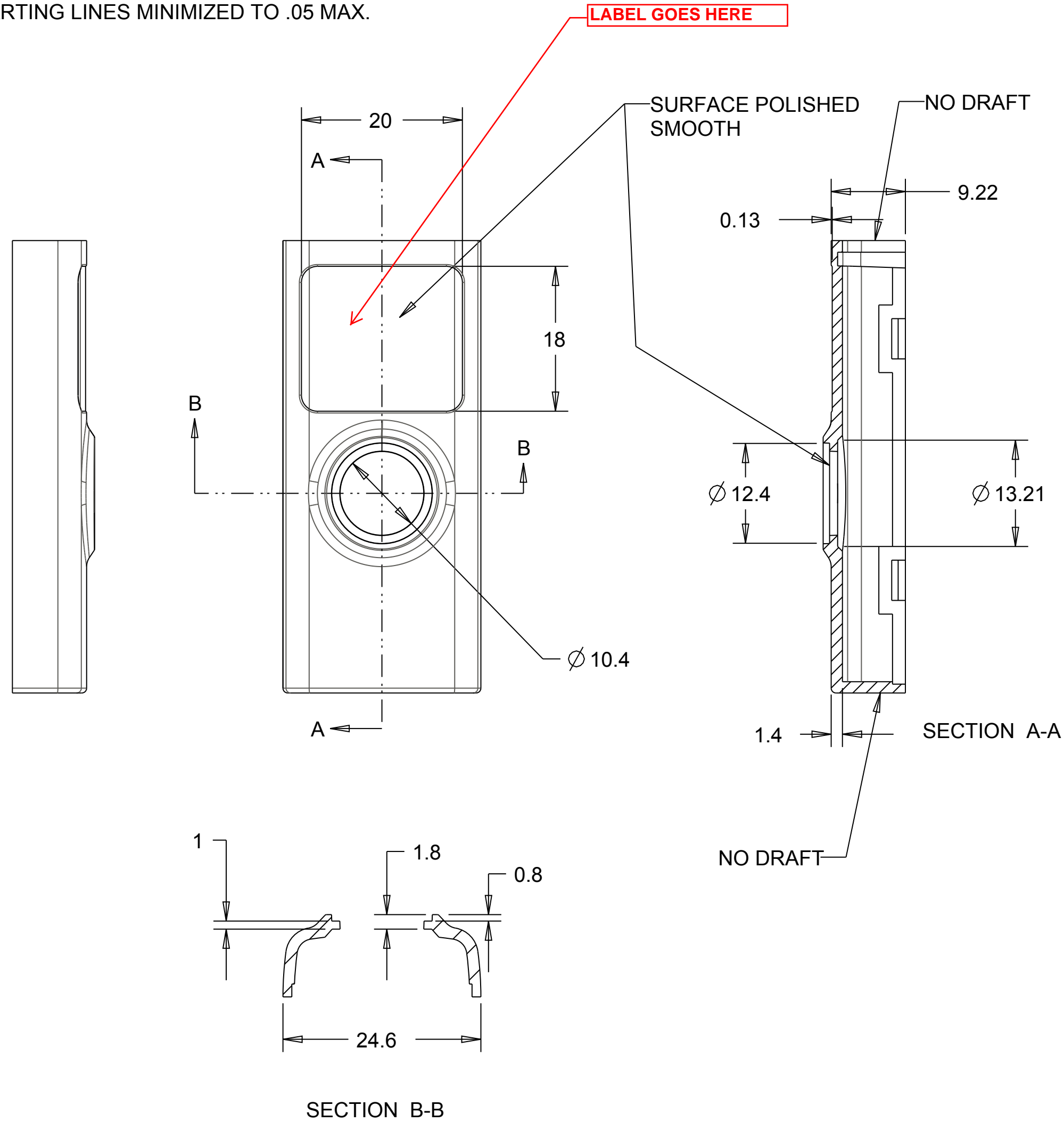

UNLESS OTHERWISE SPECIFIED ALL DIMENSIONS ARE IN MM. UNSPECIFIED TOLERANCES TO BE DETERMINED BY CHART BELOW.		<b>revolabs</b>	
		3D Model Name	1000411
.X	±.25	BACK COVER, LAPEL MIC, OPAL	
.XX	±.13	PART NUMBER : 1000411	REV. 3
.XXX	±.04	Drawn by : S.Lyman	Date : 10/01/08
ANGLES	±0.5 °	SCALE: 2.000	1 of 1