

# FCC Radio Test Report

## FCC ID: T5U-ZM100

This report concerns (check one) :  Original Grant  Class II Change

**Issued Date** : Apr 29 2008  
**Project No.** : R0711012B  
**Equipment** : IEEE 802.15.4 transceivers module  
**Model Name** : ZM100, ZM100-13, ZM100-22  
**Applicant** : Quanta Microsystems Inc  
**Address** : 188 WenHwa 2<sup>nd</sup> Rd., Kueishan Hsiang  
Taoyuan.333 Taiwan, R O C

**Tested by:**

Neutron Engineering Inc EMC Laboratory

**Date of Test:**

Apr 18, 2008 ~ Apr 24 2008

Testing Engineer : Jeff Yang  
(Jeff Yang)

Technical Manager : Steven Lu  
(Steven Lu)

Authorized Signatory : Vic Chiu  
(Vic Chiu)

### NEUTRON ENGINEERING INC.

No. 132-1, Lane 329, Sec. 2, Palain Rd.,  
Shijr City, Taipei, Taiwan  
TEL : (02) 2646-5426 FAX : (02) 2646-6815



**Declaration**

**Neutron** represents to the client that testing is done in accordance with standard procedures as applicable and that test instruments used has been calibrated with the standards traceable to National Measurement Laboratory (**NML**) of **R.O.C.**, or National Institute of Standards and Technology (**NIST**) of **U.S.A.**

**Neutron's** reports apply only to the specific samples tested under conditions. It is manufacture's responsibility to ensure that additional production units of this model are manufactured with the identical electrical and mechanical components. **Neutron** shall have no liability for any declarations, inferences or generalizations drawn by the client or others from **Neutron** issued reports.

**Neutron's** reports must not be used by the client to claim product endorsement by the authorities or any agency of the Government.

This report is the confidential property of the client. As a mutual protection to the clients, the public and **Neutron-self**, extracts from the test report shall not be reproduced except in full with **Neutron's** authorized written approval.

**Neutron's** laboratory quality assurance procedures are in compliance with the **ISO Guide 17025** requirements, and accredited by the conformity assessment authorities listed in this test report.

**Limitation**

For the use of the authority's logo is limited unless the Test Standard(s)/Scope(s)/Item(s) mentioned in this test report is (are) included in the conformity assessment authorities acceptance respective.

| Table of Contents   | Page      |
|---|-----------|
| <b>1 . CERTIFICATION</b>                                    | <b>5</b>  |
| <b>2 . SUMMARY OF TEST RESULTS</b>                          | <b>6</b>  |
| 2.1 TEST FACILITY   | 7         |
| 2.2 MEASUREMENT UNCERTAINTY                                 | 7         |
| <b>3 . GENERAL INFORMATION</b>                              | <b>8</b>  |
| 3.1 GENERAL DESCRIPTION OF EUT                              | 8         |
| 3.2 DESCRIPTION OF TEST MODES                               | 10        |
| 3.3 TABLE OF PARAMETERS OF TEXT SOFTWARE SETTING            | 10        |
| 3.4 BLOCK DIGRAM SHOWING THE CONFIGURATION OF SYSTEM TESTED | 11        |
| 3.5 DESCRIPTION OF SUPPORT UNITS(RADIATED MODE)             | 12        |
| 3.6 DESCRIPTION OF SUPPORT UNITS(CONDUCTED MODE)            | 13        |
| <b>4 . EMC EMISSION TEST</b>                                | <b>14</b> |
| 4.1 CONDUCTED EMISSION MEASUREMENT                          | 14        |
| 4.1.1 POWER LINE CONDUCTED EMISSION LIMITS                  | 14        |
| 4.1.2 MEASUREMENT INSTRUMENTS LIST AND SETTING              | 14        |
| 4.1.3 TEST PROCEDURE  | 15        |
| 4.1.4 DEVIATION FROM TEST STANDARD                          | 15        |
| 4.1.5 TEST SETUP  | 15        |
| 4.1.6 EUT OPERATING CONDITIONS                              | 15        |
| 4.1.7 TEST RESULTS  | 16        |
| 4.2 RADIATED EMISSION MEASUREMENT                           | 18        |
| 4.2.1 RADIATED EMISSION LIMITS                              | 18        |
| 4.2.2 MEASUREMENT INSTRUMENTS LIST ANS SETTING              | 19        |
| 4.2.3 TEST PROCEDURE  | 20        |
| 4.2.4 DEVIATION FROM TEST STANDARD                          | 20        |
| 4.2.5 TEST SETUP  | 21        |
| 4.2.6 EUT OPERATING CONDITIONS                              | 21        |
| 4.2.7 TEST RESULTS (BETWEEN30 – 1000 MHZ)                   | 22        |
| 4.2.8 TEST RESULTS (ABOVE 1000 MHZ)                         | 24        |
| 4.2.9 TEST RESULTS (RESTRICTED BANDS REQUIREMENTS)          | 37        |
| <b>5 . BANDWIDTH TEST</b>                                   | <b>41</b> |
| 5.1 APPLIED PROCEDURES / LIMIT                              | 41        |
| 5.1.1 MEASUREMENT INSTRUMENTS LIST                          | 41        |
| 5.1.2 TEST PROCEDURE  | 41        |
| 5.1.3 DEVIATION FROM STANDARD                               | 41        |

| Table of Contents                              | Page      |
|--|-----------|
| 5.1.4 TEST SETUP                               | 41        |
| 5.1.5 EUT OPERATION CONDITIONS                 | 41        |
| 5.1.6 TEST RESULTS                             | 42        |
| <b>6 . PEAK OUTPUT POWER TEST</b>              | <b>44</b> |
| 6.1 APPLIED PROCEDURES / LIMIT                 | 44        |
| 6.1.1 MEASUREMENT INSTRUMENTS LIST             | 44        |
| 6.1.2 TEST PROCEDURE                           | 44        |
| 6.1.3 DEVIATION FROM STANDARD                  | 44        |
| 6.1.4 TEST SETUP                               | 44        |
| 6.1.5 EUT OPERATION CONDITIONS                 | 44        |
| 6.1.6 TEST RESULTS                             | 45        |
| <b>7 . ANTENNA CONDUCTED SPURIOUS EMISSION</b> | <b>46</b> |
| 7.1 APPLIED PROCEDURES / LIMIT                 | 46        |
| 7.1.1 MEASUREMENT INSTRUMENTS LIST             | 46        |
| 7.1.2 TEST PROCEDURE                           | 46        |
| 7.1.3 DEVIATION FROM STANDARD                  | 46        |
| 7.1.4 TEST SETUP                               | 46        |
| 7.1.5 EUT OPERATION CONDITIONS                 | 47        |
| 7.1.6 TEST RESULTS                             | 48        |
| <b>8 . POWER SPECTRAL DENSITY TEST</b>         | <b>50</b> |
| 8.1 APPLIED PROCEDURES / LIMIT                 | 50        |
| 8.1.1 MEASUREMENT INSTRUMENTS LIST             | 50        |
| 8.1.2 TEST PROCEDURE                           | 50        |
| 8.1.3 DEVIATION FROM STANDARD                  | 50        |
| 8.1.4 TEST SETUP                               | 50        |
| 8.1.5 EUT OPERATION CONDITIONS                 | 50        |
| 8.1.6 TEST RESULTS                             | 51        |
| <b>9 . RF EXPOSURE TEST</b>                    | <b>53</b> |
| 9.1 APPLIED PROCEDURES / LIMIT                 | 53        |
| 9.1.1 MEASUREMENT INSTRUMENTS LIST             | 53        |
| 9.1.2 MPE CALCULATION METHOD                   | 53        |
| 9.1.3 DEVIATION FROM STANDARD                  | 54        |
| 9.1.4 TEST SETUP                               | 54        |
| 9.1.5 EUT OPERATION CONDITIONS                 | 54        |
| 9.1.6 TEST RESULTS                             | 55        |
| <b>10 . EUT TEST PHOTO</b>                     | <b>56</b> |

## 1. CERTIFICATION

Equipment : IEEE 802.15.4 transceivers module

Trade Name : QMI

Model Name : ZM100; ZM100-13; ZM100-22

Applicant : Quanta Microsystems, Inc.

Test Item : ENGINEERING SAMPLE

Standards : FCC Part15, Subpart C(15.247) / ANCI C63.4 : 2003

The above equipment has been tested and found compliance with the requirement of the relative standards by Neutron Engineering Inc. EMC Laboratory.

The test data, data evaluation, and equipment configuration contained in our test report (Ref No. NEI-FCCP-1-R0711012B) were obtained utilizing the test procedures, test instruments, test sites that has been accredited by the Authority of NVLAP and TAF according to the ISO-17025 quality assessment standard and technical standard(s).

**Test result included in this report is only for the Zigbee part of the product.**

## 2. SUMMARY OF TEST RESULTS

Test procedures according to the technical standards:

| FCC Part15 (15.247) , Subpart C |                                      |                                     |          |        |
|---------------------------------|--------------------------------------|-------------------------------------|----------|--------|
| Standard                        | Section                              | Test Item                           | Judgment | Remark |
|                                 | 15.207                               | Conducted Emission                  | PASS     |        |
|                                 | 15.247<br>(c)                        | Antenna conducted Spurious Emission | PASS     |        |
|                                 | 15.247<br>(a)(2)                     | 6dB Bandwidth                       | PASS     |        |
|                                 | 15.247<br>(b)                        | Peak Output Power                   | PASS     |        |
|                                 | 15.247<br>(c)                        | Radiated Spurious Emission          | PASS     |        |
|                                 | 15.247<br>(d)                        | Power Spectral Density              | PASS     |        |
|                                 | 15.203                               | Antenna Requirement                 | PASS     |        |
|                                 | 1.1307<br>1.1310<br>2.1091<br>2.1093 | RF Exposure Compliance              | PASS     |        |

**NOTE:**

(1) "N/A" denotes test is not applicable in this Test Report

**2.1 TEST FACILITY**

The test facilities used to collect the test data in this report is **C01/OS02** at the location of No.132-1, Lane 329, Sec. 2, Palain Road, Shijr City, Taipei, Taiwan.  
Neutron's test firm number is 95335

**2.2 MEASUREMENT UNCERTAINTY**

The reported uncertainty of measurement  $y \pm U$ , where expended uncertainty **U** is based on a standard uncertainty multiplied by a coverage factor of **k=2**, providing a level of confidence of approximately **95 %**.

**A. Conducted Measurement :**

| Test Site | Method | Measurement Frequency Range | U , (dB) | NOTE |
|-----------|--------|-----------------------------|----------|------|
| C01       | ANSI   | 150 KHz ~ 30MHz             | 1.94     |      |

**B. Radiated Measurement :**

| Test Site | Method | Measurement Frequency Range | Ant. H / V | U , (dB) | NOTE |
|-----------|--------|-----------------------------|------------|----------|------|
| OS-01     | ANSI   | 30MHz ~ 200MHz              | V          | 3.82     |      |
|           |        | 30MHz ~ 200MHz              | H          | 3.60     |      |
|           |        | 200MHz ~ 1,000MHz           | V          | 3.86     |      |
|           |        | 200MHz ~ 1,000MHz           | H          | 3.94     |      |
| OS-02     | ANSI   | 30MHz ~ 200MHz              | V          | 2.48     |      |
|           |        | 30MHz ~ 200MHz              | H          | 2.16     |      |
|           |        | 200MHz ~ 1,000MHz           | V          | 2.50     |      |
|           |        | 200MHz ~ 1,000MHz           | H          | 2.66     |      |

### 3. GENERAL INFORMATION

#### 3.1 GENERAL DESCRIPTION OF EUT

|                         |   |                      |               |                  |             |                         |         |                   |       |                      |                    |                    |                    |               |                 |
|-------------------------|---|----------------------|---------------|------------------|-------------|-------------------------|---------|-------------------|-------|----------------------|--------------------|--------------------|--------------------|---------------|-----------------|
| Equipment               | IEEE 802.15.4 transceivers module   |                      |               |                  |             |                         |         |                   |       |                      |                    |                    |                    |               |                 |
| Trade Name              | QMI   |                      |               |                  |             |                         |         |                   |       |                      |                    |                    |                    |               |                 |
| Model Name              | ZM100; ZM100-13; ZM100-22   |                      |               |                  |             |                         |         |                   |       |                      |                    |                    |                    |               |                 |
| OEM Brand/Model Name    | N/A   |                      |               |                  |             |                         |         |                   |       |                      |                    |                    |                    |               |                 |
| Model Difference        | ZM100-13: remove J1, add C1=10pF, remove VR1~4=Varistor.<br>ZM100-22: remove J1, add C1=10pF, VR1~4=Varistor<br>AVR-M1608C270MTAAB to<br>AVR-M1608C270MTABB(TDK)  |                      |               |                  |             |                         |         |                   |       |                      |                    |                    |                    |               |                 |
| Product Description     | <p>The EUT is a IEEE 802.15.4 transceivers module.</p> <table border="1"> <tr> <td>Operation Frequency:</td> <td>2405~2480 MHz</td> </tr> <tr> <td>Modulation Type:</td> <td>Offset-QPSK</td> </tr> <tr> <td>Bit Rate of Transmitter</td> <td>256Kb/s</td> </tr> <tr> <td>Number Of Channel</td> <td>16 CH</td> </tr> <tr> <td>Antenna Designation:</td> <td>Please see Note 3.</td> </tr> <tr> <td>Antenna Gain(Peak)</td> <td>Please see Note 3.</td> </tr> <tr> <td>Output Power:</td> <td>1.32 dBm (Max.)</td> </tr> </table> <p>Based on the application, features, or specification exhibited in User's Manual, the EUT is considered as an ITE/Computing Device. More details of EUT technical specification, please refer to the User's Manual.</p> | Operation Frequency: | 2405~2480 MHz | Modulation Type: | Offset-QPSK | Bit Rate of Transmitter | 256Kb/s | Number Of Channel | 16 CH | Antenna Designation: | Please see Note 3. | Antenna Gain(Peak) | Please see Note 3. | Output Power: | 1.32 dBm (Max.) |
| Operation Frequency:    | 2405~2480 MHz   |                      |               |                  |             |                         |         |                   |       |                      |                    |                    |                    |               |                 |
| Modulation Type:        | Offset-QPSK   |                      |               |                  |             |                         |         |                   |       |                      |                    |                    |                    |               |                 |
| Bit Rate of Transmitter | 256Kb/s   |                      |               |                  |             |                         |         |                   |       |                      |                    |                    |                    |               |                 |
| Number Of Channel       | 16 CH   |                      |               |                  |             |                         |         |                   |       |                      |                    |                    |                    |               |                 |
| Antenna Designation:    | Please see Note 3.  |                      |               |                  |             |                         |         |                   |       |                      |                    |                    |                    |               |                 |
| Antenna Gain(Peak)      | Please see Note 3.  |                      |               |                  |             |                         |         |                   |       |                      |                    |                    |                    |               |                 |
| Output Power:           | 1.32 dBm (Max.)   |                      |               |                  |             |                         |         |                   |       |                      |                    |                    |                    |               |                 |
| Channel List            | Please refer to the Note 2.   |                      |               |                  |             |                         |         |                   |       |                      |                    |                    |                    |               |                 |
| Power Source            | DC Voltage supplied from System   |                      |               |                  |             |                         |         |                   |       |                      |                    |                    |                    |               |                 |
| Power Rating            | DC 5V (IN) power regulation 3.3Vdc to the module  |                      |               |                  |             |                         |         |                   |       |                      |                    |                    |                    |               |                 |
| Connecting I/O Port(s)  | Please refer to the User's Manual   |                      |               |                  |             |                         |         |                   |       |                      |                    |                    |                    |               |                 |
| Products Covered        | N/A   |                      |               |                  |             |                         |         |                   |       |                      |                    |                    |                    |               |                 |

Note:

1. For a more detailed features description, please refer to the manufacturer's specifications or the User's Manual.



2.

| Frequency Band | Channel No. | Frequency |
|----------------|-------------|-----------|
| 2400~2483.5MHz | 1           | 2405 MHz  |
|                | 2           | 2410 MHz  |
|                | 3           | 2415 MHz  |
|                | 4           | 2420 MHz  |
|                | 5           | 2425 MHz  |
|                | 6           | 2430 MHz  |
|                | 7           | 2435 MHz  |
|                | 8           | 2440 MHz  |
|                | 9           | 2445 MHz  |
|                | 10          | 2450 MHz  |
|                | 11          | 2455 MHz  |
|                | 12          | 2460 MHz  |
|                | 13          | 2465 MHz  |
|                | 14          | 2470 MHz  |
|                | 15          | 2475 MHz  |
|                | 16          | 2480 MHz  |

3.

Table for Filed Antenna

| Ant. | Brand | Model Name | Antenna Type    | Connector | Gain (dBi) |
|------|-------|------------|-----------------|-----------|------------|
| 1    | N/A   | N/A        | Printed Antenna | NA        | 2.5        |

**3.2 DESCRIPTION OF TEST MODES**

To investigate the maximum EMI emission characteristics generates from EUT, the test system was pre-scanning tested base on the consideration of following EUT operation mode or test configuration mode which possible have effect on EMI emission level. Each of these EUT operation mode(s) or test configuration mode(s) mentioned above was evaluated respectively.

| Test Items  | Mode        | Data Rate | Channel | Antenna |
|---|-------------|-----------|---------|---------|
| AC Power Line Conducted Emissions   | Normal Link | 256Kb/s   | 1       | 1       |
| Maximum Peak Conducted Output Power<br>Power Spectral Density<br>6dB Spectrum Bandwidth | Zigbee      | 256Kb/s   | 1/8/16  | 1       |
| Radiated Emissions 9kHz~1GHz  | Zigbee      | 256Kb/s   | 8       | 1       |
| Radiated Emissions 1GHz~10 <sup>th</sup> Harmonic                                       | Zigbee      | 256Kb/s   | 1/8/16  | 1       |
| Band Edge Emissions   | Zigbee      | 256Kb/s   | 1/16    | 1       |

Note:

(1) The measurements are performed at the highest, middle, lowest available channels.

**3.3 TABLE OF PARAMETERS OF TEXT SOFTWARE SETTING**

During testing channel & power controlling software provided by the customer was used to control the operating channel as well as the output power level. The RF output power selection is for the setting of RF output power expected by the customer and is going to be fixed on the firmware of the final end product power parameters of Zigbee

| Test software Version | Test Program:Hyper Terminal(packet function) |          |          |
|-----------------------|--|----------|----------|
| Frequency             | 2405 MHz                                     | 2440 MHz | 2480 MHz |
| Parameters            | q  | q        | q        |

3.4 BLOCK DIGRAM SHOWING THE CONFIGURATION OF SYSTEM TESTED

Radiated Mode:

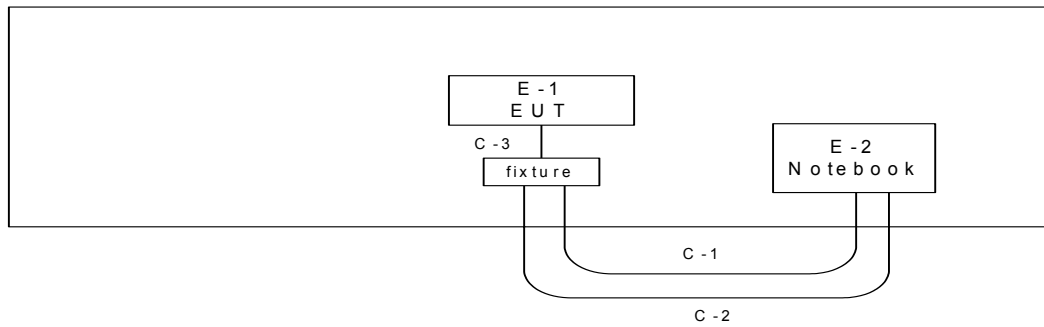

Conducted Mode:

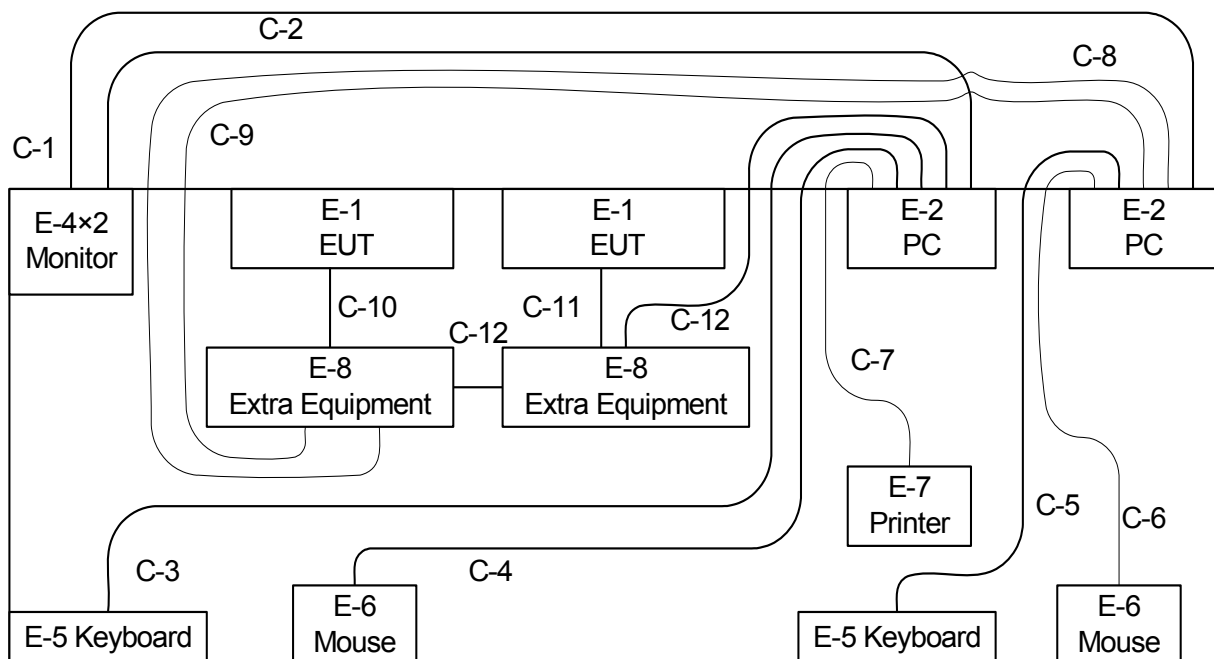

- |                   |                  |
|-------------------|------------------|
| C-1 D-SUB Cable   | C-8 RS232 Cable  |
| C-2 D-SUB Cable   | C-9 USB Cable    |
| C-3 PS/2 Cable    | C-10 Data Cable  |
| C-4 PS/2 Cable    | C-11 Data Cable  |
| C-5 PS/2 Cable    | C-12 RS232 Cable |
| C-6 PS/2 Cable    | C-13 Power Cable |
| C-7 Paralle Cable |                  |

**3.5 DESCRIPTION OF SUPPORT UNITS(RADIATED MODE)**

The EUT has been tested as an independent unit together with other necessary accessories or support units. The following support units or accessories were used to form a representative test configuration during the tests.

| Item | Equipment                         | Mfr/Brand | Model/Type No. | FCC ID    | Series No. | Note |
|------|-----------------------------------|-----------|----------------|-----------|------------|------|
| E-1  | IEEE 802.15.4 transceivers module | QMI       | ZM100          | T5U-ZM100 | N/A        | EUT  |
| E-2  | Notebook PC                       | DELL      | D600           | DOC       | 7T390 A03  |      |
|      |                                   |           |                |           |            |      |

| Item | Shielded Type | Ferrite Core | Length | Note   |
|------|---------------|--------------|--------|--------|
| C-1  | NO            | NO           | 1.8M   | RS-232 |
| C-2  | NO            | NO           | 1.8M   | USB    |
| C-3  | NO            | NO           | 0.01M  | Cable  |

Note:

- (1) The support equipment was authorized by Declaration of Confirmation.
- (2) For detachable type I/O cable should be specified the length in cm in 『Length』 column.

**3.6 DESCRIPTION OF SUPPORT UNITS(CONDUCTED MODE)**

The EUT has been tested as an independent unit together with other necessary accessories or support units. The following support units or accessories were used to form a representative test configuration during the tests.

| Item | Equipment                         | Mfr/Brand | Model/Type No.      | FCC ID    | Series No.      | Note |
|------|-----------------------------------|-----------|---------------------|-----------|-----------------|------|
| E-1  | IEEE 802.15.4 transceivers module | QMI       | ZM100               | T5U-ZM100 | N/A             | EUT  |
| E-2  | PC                                | HP        | HP Compaq dx7300 MT | DOC       | SGH71505LH      |      |
| E-3  | PC                                | DELL      | MVT01               | DOC       | 4GCTR18         |      |
| E-4  | 19" LCD Monitor                   | Samsung   | SyncMaster 193P     | DOC       | DI19H4JXC05517A |      |
| E-5  | PS/2 K/B                          | Logitech  | Y-SJ17(ACK260A)     | DOC       | SYU44664880     |      |
| E-6  | PS/2 Mouse                        | Logitech  | M-SBF69             | DOC       | HCA44601156     |      |
| E-7  | Printer                           | SII       | DPU-414             | DOC       | 1045105A        |      |
| E-8  | Extra Equipment                   | N/A       | N/A                 | N/A       | N/A             |      |

| Item | Shielded Type | Ferrite Core | Length | Note |
|------|---------------|--------------|--------|------|
| C-1  | YES           | YES          | 1.8M   |      |
| C-2  | YES           | YES          | 1.8M   |      |
| C-3  | YES           | NO           | 1.5M   |      |
| C-4  | YES           | NO           | 1.5M   |      |
| C-5  | YES           | NO           | 1.5M   |      |
| C-6  | YES           | NO           | 1.5M   |      |
| C-7  | YES           | NO           | 1.5M   |      |
| C-8  | YES           | NO           | 1.7M   |      |
| C-9  | YES           | NO           | 1.7M   |      |
| C-10 | NO            | NO           | 0.3M   |      |
| C-11 | NO            | NO           | 0.3M   |      |
| C-12 | YES           | NO           | 1.7M   |      |
| C-13 | NO            | NO           | 0.1M   |      |

Note:

- (1) The support equipment was authorized by Declaration of Confirmation.
- (2) For detachable type I/O cable should be specified the length in cm in 『Length』 column.

**4. EMC EMISSION TEST**

**4.1 CONDUCTED EMISSION MEASUREMENT**

**4.1.1 POWER LINE CONDUCTED EMISSION Limits (Frequency Range 150KHz-30MHz)**

| FREQUENCY (MHz) | Class A (dBuV) |         | Class B (dBuV) |           | Standard |
|-----------------|----------------|---------|----------------|-----------|----------|
|                 | Quasi-peak     | Average | Quasi-peak     | Average   |          |
| 0.15 -0.5       | 79.00          | 66.00   | 66 - 56 *      | 56 - 46 * | CISPR    |
| 0.50 -5.0       | 73.00          | 60.00   | 56.00          | 46.00     | CISPR    |
| 5.0 -30.0       | 73.00          | 60.00   | 60.00          | 50.00     | CISPR    |

|           |       |       |           |           |     |
|-----------|-------|-------|-----------|-----------|-----|
| 0.15 -0.5 | 79.00 | 66.00 | 66 - 56 * | 56 - 46 * | FCC |
| 0.50 -5.0 | 73.00 | 60.00 | 56.00     | 46.00     | FCC |
| 5.0 -30.0 | 73.00 | 60.00 | 60.00     | 50.00     | FCC |

Note:

- (1) The tighter limit applies at the band edges.
- (2) The limit of " \* " marked band means the limitation decreases linearly with the logarithm of the frequency in the range.

**4.1.2 MEASUREMENT INSTRUMENTS LIST AND SETTING**

| Item | Kind of Equipment | Manufacturer    | Type No. | Serial No. | Calibrated until |
|------|-------------------|-----------------|----------|------------|------------------|
| 1    | LISN              | EMCO            | 3816/2   | 00042991   | Jan. 24, 2009    |
| 2    | LISN              | EMCO            | 3816/2   | 00042990   | Jan. 24, 2009    |
| 3    | Pulse Limiter     | Electro-Metrics | EM-7600  | 112644     | Nov. 27, 2008    |
| 4    | 50Ω Terminator    | N/A             | N/A      | N/A        | May.13, 2009     |
| 5    | Test Cable        | N/A             | C01      | N/A        | Nov. 27, 2008    |
| 6    | EMI Test Receiver | R&S             | ESCI     | 100082     | Mar. 07, 2009    |

Remark: " N/A" denotes No Model Name. , Serial No. or No Calibration specified.

The following table is the setting of the receiver

| Receiver Parameters | Setting  |
|---------------------|----------|
| Attenuation         | 10 dB    |
| Start Frequency     | 0.15 MHz |
| Stop Frequency      | 30 MHz   |
| IF Bandwidth        | 9 kHz    |

#### 4.1.3 TEST PROCEDURE

- a. The EUT was placed 0.4 meters from the horizontal ground plane with EUT being connected to the power mains through a line impedance stabilization network (LISN). All other support equipments powered from additional LISN(s). The LISN provide 50 Ohm/ 50uH of coupling impedance for the measuring instrument.
- b. Interconnecting cables that hang closer than 40 cm to the ground plane shall be folded back and forth in the center forming a bundle 30 to 40 cm long.
- c. I/O cables that are not connected to a peripheral shall be bundled in the center. The end of the cable may be terminated, if required, using the correct terminating impedance. The overall length shall not exceed 1 m.
- d. LISN at least 80 cm from nearest part of EUT chassis.
- e. For the actual test configuration, please refer to the related Item –EUT Test Photos.

#### 4.1.4 DEVIATION FROM TEST STANDARD

No deviation

#### 4.1.5 TEST SETUP

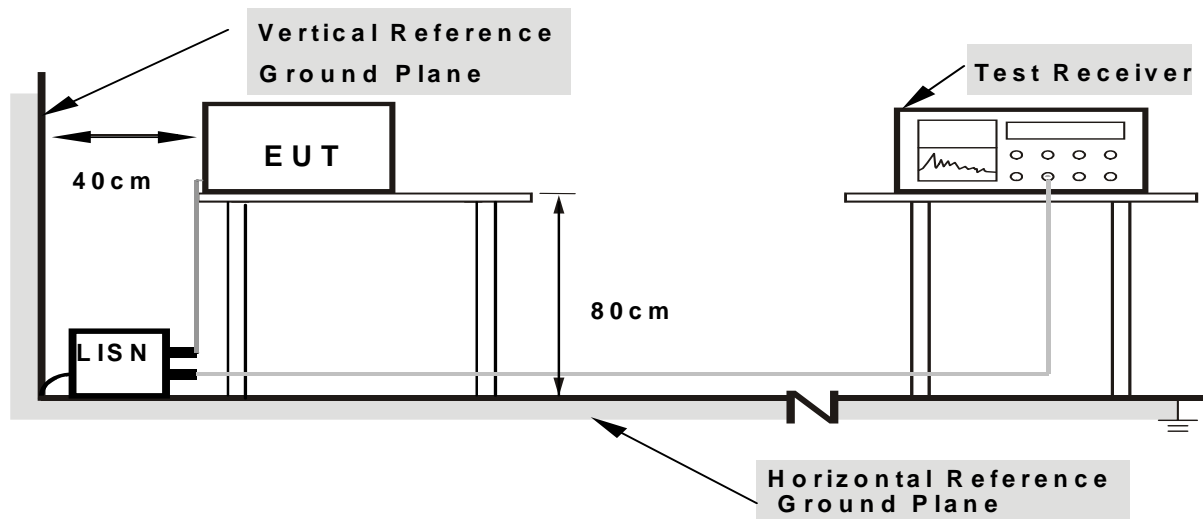

**Note: 1.** Support units were connected to second LISN.

**2.** Both of LISNs (AMN) are 80 cm from EUT and at least 80 cm from other units and other metal planes

#### 4.1.6 EUT OPERATING CONDITIONS

The EUT was configured for testing in a typical fashion (as a customer would normally use it). The EUT has been programmed to continuously transmit during test. This operating condition was tested and used to collect the included data.

The eut power from System DC 5V (IN) power regulation 3.3Vdc to the module

4.1.7 TEST RESULTS

|               |                                   |                     |              |
|---------------|-----------------------------------|---------------------|--------------|
| EUT :         | IEEE 802.15.4 transceivers module | Model Name. :       | ZM100        |
| Temperature : | 25 °C                             | Relative Humidity : | 55 %         |
| Pressure :    | 1009hPa                           | Test Power :        | AC 120V/60Hz |
| Test Mode :   | Mode 1                            |                     |              |

| Freq. (MHz) | Terminal L/N | Measured(dBuV) |         | Limits(dBuV) |         | Margin (dB) | Note |
|-------------|--------------|----------------|---------|--------------|---------|-------------|------|
|             |              | QP-Mode        | AV-Mode | QP-Mode      | AV-Mode |             |      |
| 0.15        | Line         | 51.74          | *       | 66.00        | 56.00   | -14.26      | (QP) |
| 0.17        | Line         | 51.75          | *       | 64.98        | 54.98   | -13.23      | (QP) |
| 0.21        | Line         | 49.25          | *       | 63.23        | 53.23   | -13.98      | (QP) |
| 0.29        | Line         | 42.02          | *       | 60.65        | 50.65   | -18.63      | (QP) |
| 1.65        | Line         | 37.08          | *       | 56.00        | 46.00   | -18.92      | (QP) |
| 9.95        | Line         | 40.22          | *       | 60.00        | 50.00   | -19.78      | (QP) |

Remark

- (1) All readings are QP Mode value unless otherwise stated AVG in column of Note. If the QP Mode Measured value compliance with the QP Limits and lower than AVG Limits, the EUT shall be deemed to meet both QP & AVG Limits and then only QP Mode was measured, but AVG Mode didn't perform. In this case, a "\*" marked in AVG Mode column of Interference Voltage Measured.
- (2) Measuring frequency range from 150KHz to 30MHz.

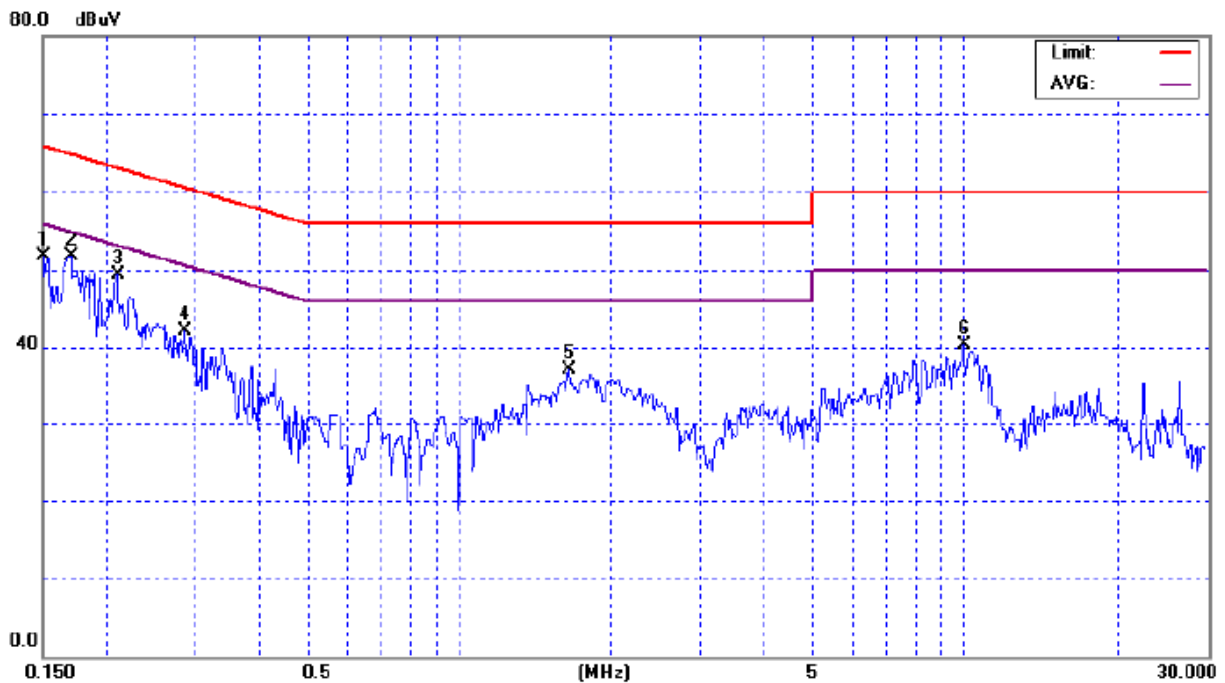



|               |                                   |                     |              |
|---------------|-----------------------------------|---------------------|--------------|
| EUT :         | IEEE 802.15.4 transceivers module | Model Name. :       | ZM100        |
| Temperature : | 25 °C                             | Relative Humidity : | 55 %         |
| Pressure :    | 1009hPa                           | Test Power :        | AC 120V/60Hz |
| Test Mode :   | Mode 1                            |                     |              |

| Freq. (MHz) | Terminal L/N | Measured(dBuV) |         | Limits(dBuV) |         | Margin (dB) | Note |
|-------------|--------------|----------------|---------|--------------|---------|-------------|------|
|             |              | QP-Mode        | AV-Mode | QP-Mode      | AV-Mode |             |      |
| 0.15        | Neutral      | 52.76          | *       | 65.88        | 55.88   | -13.12      | (QP) |
| 0.17        | Neutral      | 51.46          | *       | 64.95        | 54.95   | -13.49      | (QP) |
| 0.22        | Neutral      | 48.89          | *       | 62.93        | 52.93   | -14.04      | (QP) |
| 0.25        | Neutral      | 45.60          | *       | 61.92        | 51.92   | -16.32      | (QP) |
| 1.68        | Neutral      | 36.91          | *       | 56.00        | 46.00   | -19.09      | (QP) |
| 10.65       | Neutral      | 39.73          | *       | 60.00        | 50.00   | -20.27      | (QP) |

Remark

- (1) All readings are QP Mode value unless otherwise stated AVG in column of "Note". If the QP Mode Measured value compliance with the QP Limits and lower than AVG Limits, the EUT shall be deemed to meet both QP & AVG Limits and then only QP Mode was measured, but AVG Mode didn't perform. In this case, a "\*" marked in AVG Mode column of Interference Voltage Measured.
- (2) Measuring frequency range from 150KHz to 30MHz.

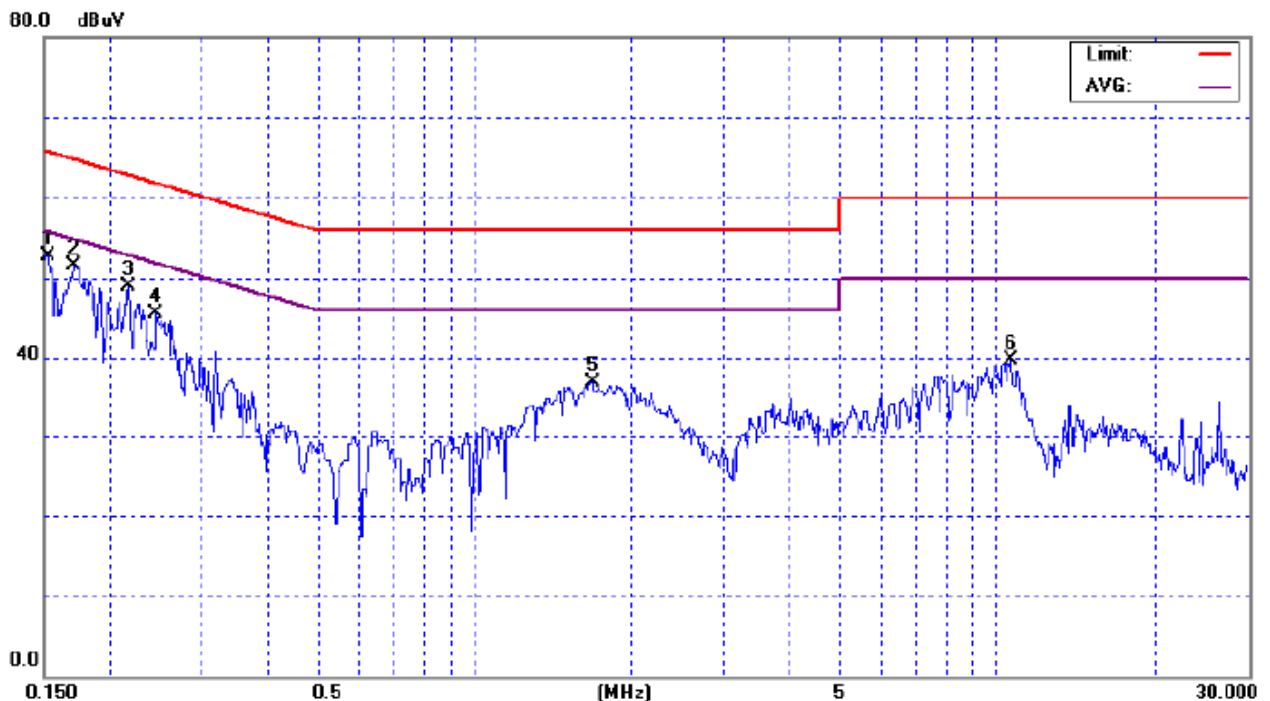

**4.2 RADIATED EMISSION MEASUREMENT**

**4.2.1 RADIATED EMISSION LIMITS (Frequency Range 9KHz-1000MHz)**

20dBc in any 100 kHz bandwidth outside the operating frequency band. In case the emission fall within the restricted band specified on 15.205(a), then the 15.209(a) limit in the table below has to be followed.

| Frequencies (MHz) | Field Strength (micorvolts/meter) | Measurement Distance (meters) |
|-------------------|-----------------------------------|-------------------------------|
| 0.009~0.490       | 2400/F(KHz)                       | 300                           |
| 0.490~1.705       | 24000/F(KHz)                      | 30                            |
| 1.705~30.0        | 30                                | 30                            |
| 30~88             | 100                               | 3                             |
| 88~216            | 150                               | 3                             |
| 216~960           | 200                               | 3                             |
| Above 960         | 500                               | 3                             |

LIMITS OF RADIATED EMISSION MEASUREMENT (Above 1000MHz)

| FREQUENCY (MHz) | Class A (dBuV/m) (at 3m) |         | Class B (dBuV/m) (at 3m) |         |
|-----------------|--------------------------|---------|--------------------------|---------|
|                 | PEAK                     | AVERAGE | PEAK                     | AVERAGE |
| Above 1000      | 80                       | 60      | 74                       | 54      |

Notes:

- (1) The limit for radiated test was performed according to FCC PART 15B.
- (2) The tighter limit applies at the band edges.
- (3) Emission level (dBuV/m)=20log Emission level (uV/m).

FREQUENCY RANGE OF RADIATED MEASUREMENT (For unintentional radiators)

| Highest frequency generated or Upper frequency of measurement used in the device or on which the device operates or tunes (MHz) | Range (MHz)   |
|---|---|
| Below 1.705   | 30  |
| 1.705 – 108   | 1000  |
| 108 – 500   | 2000  |
| 500 – 1000  | 5000  |
| Above 1000  | 5 <sup>th</sup> harmonic of the highest frequency or 40 GHz, whichever is lower |

**4.2.2 MEASUREMENT INSTRUMENTS LIST AND SETTING**

| Item | Kind of Equipment       | Manufacturer     | Type No.     | Serial No. | Calibrated until |
|------|-------------------------|------------------|--------------|------------|------------------|
| 1    | Log-Bicon Antenna       | Schwarzbeck      | VULB 9160    | 3176       | Apr. 12, 2008    |
| 2    | Test Cable              | N/A              | 10M_OS01     | N/A        | Oct. 10, 2008    |
| 3    | Test Cable              | N/A              | OS01-1/-2    | N/A        | Oct. 10, 2008    |
| 4    | Pre-Amplifier           | Anritsu          | MH648A(OS01) | M09961     | Oct. 10, 2008    |
| 5    | Test Cable              | N/A              | SR03_C       | N/A        | Aug. 20, 2008    |
| 6    | EMI Test Receiver       | R&S              | ESCI         | 100080     | Mar. 08, 2009    |
| 7    | Spectrum Analyzer       | ADVAN TEST       | R3261C       | 81720298   | Sep. 12, 2008    |
| 8    | Spectrum Analyzer       | R&S              | FSP_40       | 100129     | Aug. 16, 2008    |
| 9    | Horn Antenna            | EMCO             | 3115         | 9120D-325  | Aug. 19, 2008    |
| 10   | Microwave Pre-amplifier | Agilent          | 8449B        | 3008A01714 | May. 14, 2008    |
| 11   | Microflex Cable         | United Microwave | 57793        | 1m         | May. 13, 2008    |
| 12   | Microflex Cable         | United Microwave | A30A30-5006  | 10M        | Jul. 24, 2008    |

Remark: " N/A" denotes No Model Name / Serial No. and No Calibration specified.

| Spectrum Parameter                    | Setting  |
|---------------------------------------|--|
| Attenuation                           | Auto   |
| Start Frequency                       | 1000 MHz   |
| Stop Frequency                        | 10th carrier harmonic  |
| RB / VB (emission in restricted band) | 1MHz / 1MHz for Peak<br>Average = Peak value + 20 log (Duty cycle) |
| RB / VB (other emission)              | 100KHz / 100KHz for peak   |

| Receiver Parameter     | Setting                          |
|------------------------|----------------------------------|
| Attenuation            | Auto                             |
| Start ~ Stop Frequency | 9kHz~150kHz / RB 200Hz for QP    |
| Start ~ Stop Frequency | 150kHz~30MHz / RB 9kHz for QP    |
| Start ~ Stop Frequency | 30MHz~1000MHz / RB 120kHz for QP |

#### **4.2.3 TEST PROCEDURE**

- a. The measuring distance of at 3 m shall be used for measurements at frequency up to 1GHz. For frequencies above 1GHz, any suitable measuring distance may be used.
- b. The EUT was placed on the top of a rotating table 0.8 meters above the ground at a 3 meter open area test site. The table was rotated 360 degrees to determine the position of the highest radiation.
- c. The height of the equipment or of the substitution antenna shall be 0.8 m; the height of the test antenna shall vary between 1 m to 4 m. Both horizontal and vertical polarizations of the antenna are set to make the measurement.
- d. The initial step in collecting conducted emission data is a spectrum analyzer peak detector mode pre-scanning the measurement frequency range. Significant peaks are then marked and then Quasi Peak detector mode re-measured.
- e. If the Peak Mode measured value compliance with and lower than Quasi Peak Mode Limit, the EUT shall be deemed to meet QP Limits and then no additional QP Mode measurement performed.
- f. For the actual test configuration, please refer to the related Item –EUT Test Photos.

#### **4.2.4 DEVIATION FROM TEST STANDARD**

No deviation

#### 4.2.5 TEST SETUP

(A) Radiated Emission Test Set-Up, Frequency Below 1000MHz

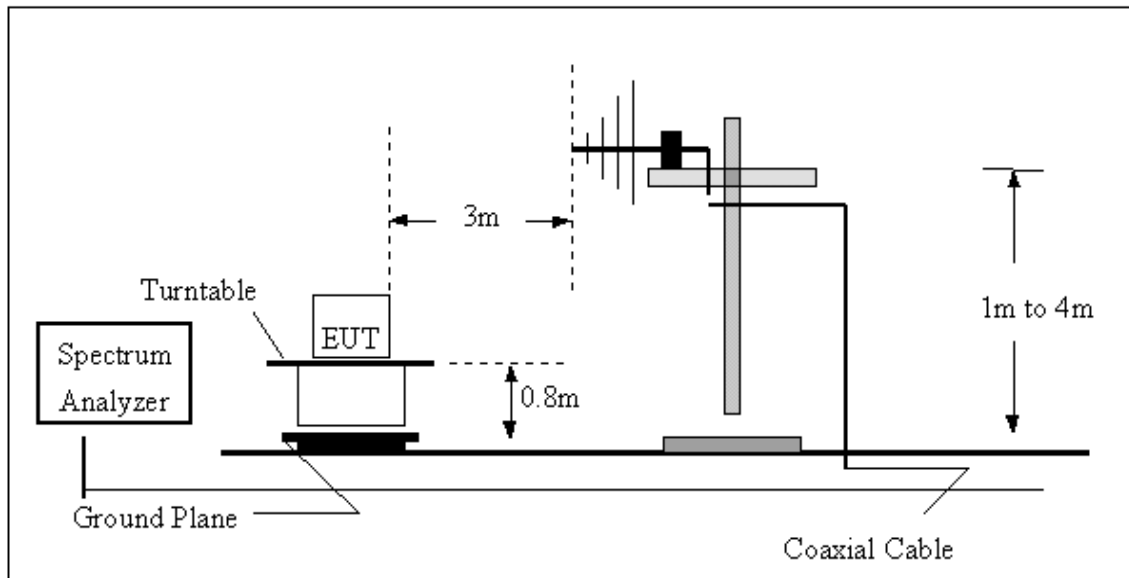

(B) Radiated Emission Test Set-Up Frequency Above 1 GHz

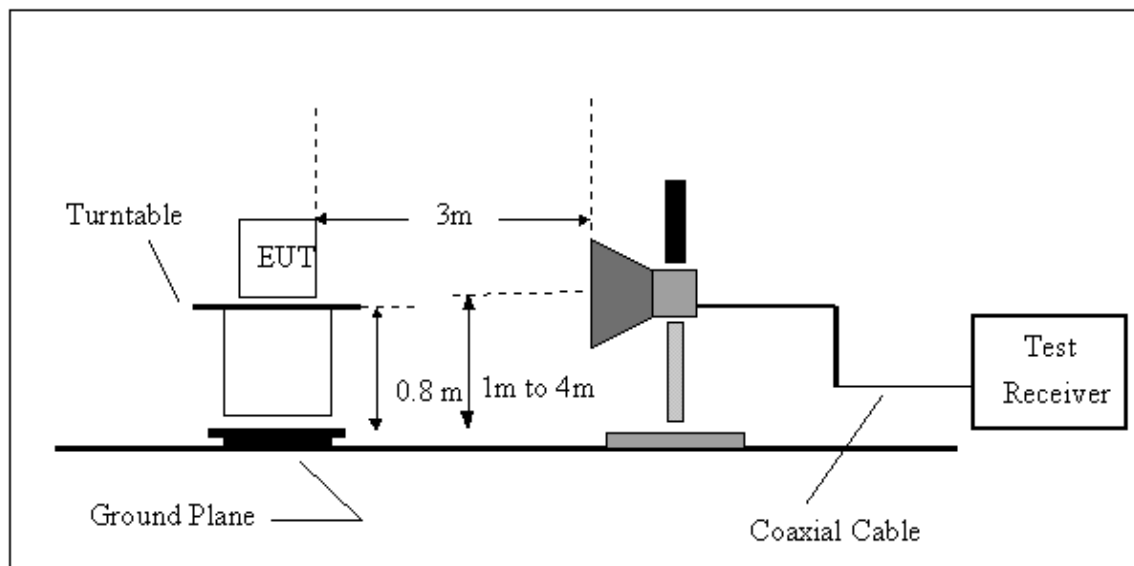

#### 4.2.6 EUT OPERATING CONDITIONS

The EUT tested system was configured as the statements of 4.1.6 Unless otherwise a special operating condition is specified in the follows during the testing.

4.2.7 TEST RESULTS (BETWEEN30 – 1000 MHZ)

|               |                                   |                     |              |
|---------------|-----------------------------------|---------------------|--------------|
| EUT :         | IEEE 802.15.4 transceivers module | Model Name. :       | ZM100        |
| Temperature : | 24 °C                             | Relative Humidity : | 65%          |
| Pressure :    | 1016 hPa                          | Test Voltage :      | AC 120V/60Hz |
| Test Mode :   | TX 2440MHz - CH 08                |                     |              |

| Freq. (MHz) | Ant. H/V | Reading(RA) (dBuV) | Corr.Factor(CF) (dB) | Measured(FS) (dBuV/m) | Limits(QP) (dBuV/m) | Margin (dB) | Note |
|-------------|----------|--------------------|----------------------|-----------------------|---------------------|-------------|------|
| 72.68       | V        | 28.14              | -6.90                | 21.24                 | 40.00               | - 18.76     |      |
| 99.84       | V        | 29.57              | -7.05                | 22.52                 | 43.50               | - 20.98     |      |
| 220.12      | V        | 26.75              | -3.48                | 23.27                 | 46.00               | - 22.73     |      |
| 249.22      | V        | 32.22              | -2.69                | 29.53                 | 46.00               | - 16.47     |      |
| 336.52      | V        | 31.18              | 0.19                 | 31.37                 | 46.00               | - 14.63     |      |
| 365.62      | V        | 32.37              | 1.85                 | 34.22                 | 46.00               | - 11.78     |      |

Remark :

- (1) Reading in which marked as QP or Peak means measurements by using are Quasi-Peak Mode or Peak Mode with Detector BW=120KHz : SPA setting in RBW=120KHz, VBW =120KHz, Swp. Time = 0.3 sec./MHz ◦
- (2) All readings are Peak unless otherwise stated QP in column of 『 Note 』 . Peak denotes that the Peak reading compliance with the QP Limits and then QP Mode measurement didn't perform ◦
- (3) Measuring frequency range from 30MHz to 1000MHz ◦
- (4) If the peak scan value lower limit more than 20dB, then this signal data does not show in table ◦

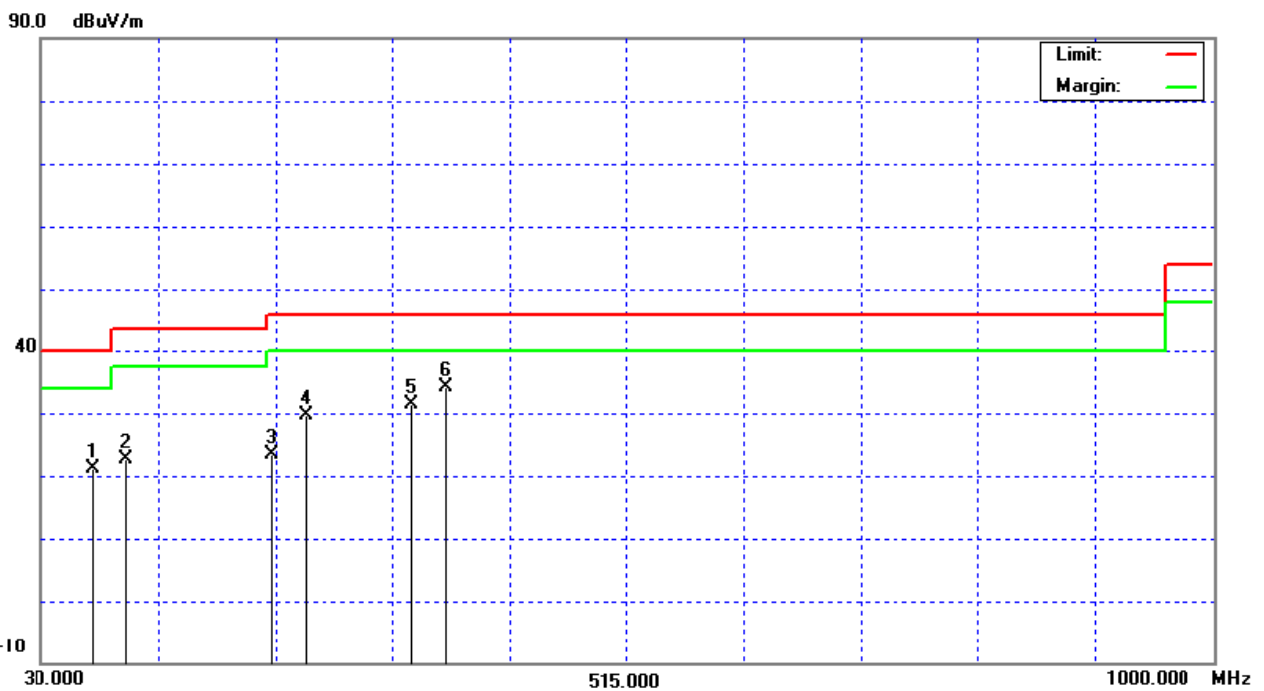

|               |                                   |                     |              |
|---------------|-----------------------------------|---------------------|--------------|
| EUT :         | IEEE 802.15.4 transceivers module | Model Name. :       | ZM100        |
| Temperature : | 24 °C                             | Relative Humidity : | 65%          |
| Pressure :    | 1016 hPa                          | Test Voltage :      | AC 120V/60Hz |
| Test Mode :   | TX 2440MHz - CH 08                |                     |              |

| Freq. (MHz) | Ant. H/V | Reading(RA) (dBuV) | Corr.Factor(CF) (dB) | Measured(FS) (dBuV/m) | Limits(QP) (dBuV/m) | Margin (dB) | Note |
|-------------|----------|--------------------|----------------------|-----------------------|---------------------|-------------|------|
| 72.68       | H        | 31.53              | -6.90                | 24.63                 | 40.00               | - 15.37     |      |
| 220.12      | H        | 29.15              | -3.48                | 25.67                 | 46.00               | - 20.33     |      |
| 299.66      | H        | 28.14              | -0.62                | 27.52                 | 46.00               | - 18.48     |      |
| 336.52      | H        | 24.86              | 0.19                 | 25.05                 | 46.00               | - 20.95     |      |
| 365.62      | H        | 33.26              | 1.85                 | 35.11                 | 46.00               | - 10.89     |      |
| 499.48      | H        | 28.81              | 4.77                 | 33.58                 | 46.00               | - 12.42     |      |

Remark :

- (1) Reading in which marked as QP or Peak means measurements by using are Quasi-Peak Mode or Peak Mode with Detector BW=120KHz ; SPA setting in RBW=120KHz, VBW =120KHz, Swp. Time = 0.3 sec./MHz ◦
- (2) All readings are Peak unless otherwise stated QP in column of 『 Note 』 . Peak denotes that the Peak reading compliance with the QP Limits and then QP Mode measurement didn't perform ◦
- (3) Measuring frequency range from 30MHz to 1000MHz ◦
- (4) If the peak scan value lower limit more than 20dB, then this signal data does not show in table ◦

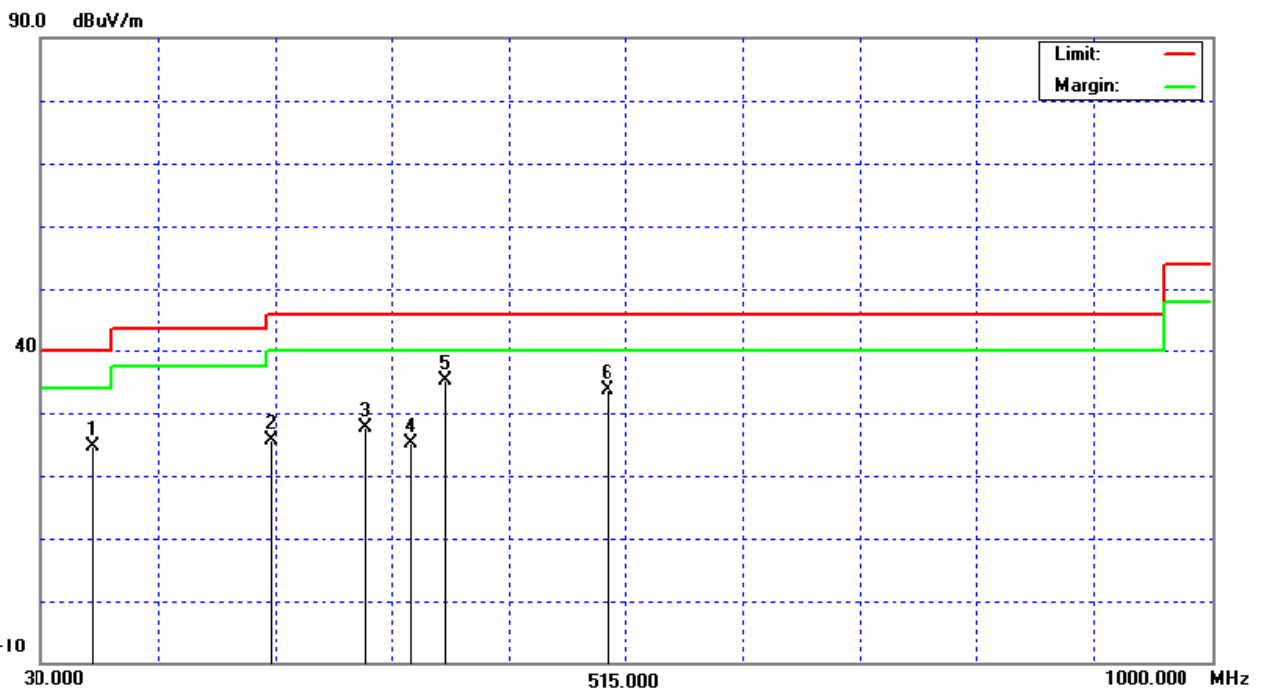

**4.2.8 TEST RESULTS (ABOVE 1000 MHZ)**

|               |                                   |                     |              |
|---------------|-----------------------------------|---------------------|--------------|
| EUT :         | IEEE 802.15.4 transceivers module | Model Name. :       | ZM100        |
| Temperature : | 24 °C                             | Relative Humidity : | 65%          |
| Pressure :    | 1016 hPa                          | Test Voltage :      | AC 120V/60Hz |
| Test Mode :   | TX 2405MHz - CH 01                |                     |              |

| Freq.          | Ant.Pol. | Reading      |              | Ant./CF      | Act.         |              | Limit    |          | Note       |
|----------------|----------|--------------|--------------|--------------|--------------|--------------|----------|----------|------------|
|                |          | Peak         | AV           |              | Peak         | AV           | Peak     | AV       |            |
| (MHz)          | H/V      | (dBuV)       | (dBuV)       | CF(dB)       | (dBuV/m)     | (dBuV/m)     | (dBuV/m) | (dBuV/m) |            |
| 2390.00        | V        | 17.81        | -10.89       | 32.57        | 50.38        | 21.68        | 74.00    | 54.00    | Y/E        |
| <b>2404.90</b> | <b>V</b> | <b>57.67</b> | <b>28.97</b> | <b>32.66</b> | <b>90.33</b> | <b>61.63</b> |          |          | <b>Y/F</b> |
| 4808.86        | V        | 48.04        | 19.34        | 3.97         | 52.01        | 23.31        | 74.00    | 54.00    | Y/H        |

Remark :

- (1) All readings are Peak unless otherwise stated QP in column of 『Note』 . Peak denotes that the Peak reading compliance with the QP Limits and then QP Mode measurement didn't perform .
- (2) Measuring frequency range from 30MHz to 1000MHz or the 10th harmonic of highest fundamental frequency . "F" denotes fundamental frequency; "H" denotes spurious frequency. "E" denotes band edge frequency. (This judgment method includes the Band Edge Requirement.)
- (3) Radiated emissions measured in frequency range above 1000MHz were made with an instrument using Peak detector mode and AV detector mode of the emission .
- (4) Data of measurement within this frequency range shown " \* " in the table above means the reading of emissions are attenuated more than 20dB below the permissible limits or the field strength is too small to be measured.
- (5) A preamp and high pass filter were used for this test in order to provide sufficient measurement sensitivity.
- (6) EUT Orthogonal Axis :  
 "X" - denotes Laid on Table ; "Y" - denotes Vertical Stand ; "Z" - denotes Side Stand
- (7) The average of fundamental frequency is Average = Peak value + 20 log (Duty cycle)  
 Where the duty factor is calculated from following formula:  
 $20 \log (\text{Duty cycle}) = 20 \log ( 1.1\text{ms}/30\text{ms}) = -28.71 \text{ dB}$   
 Please see page 36 for plotted duty



TX CH01 (Above 1000 MHz, Vertical)

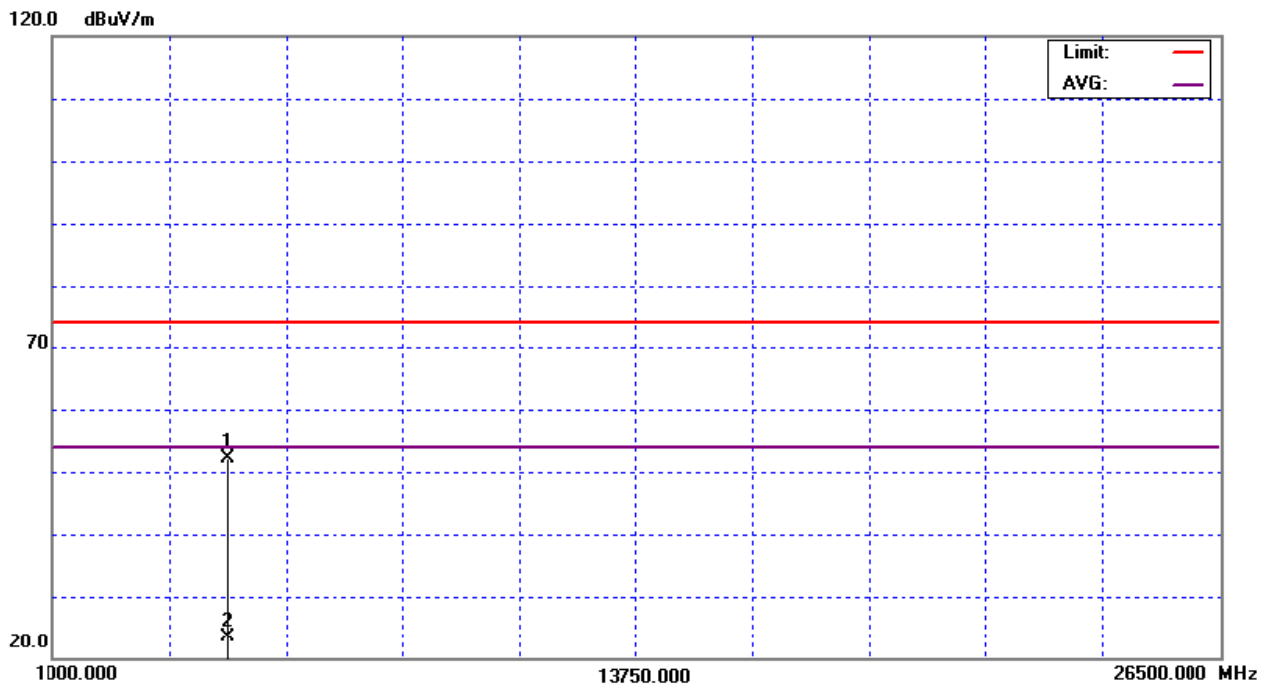
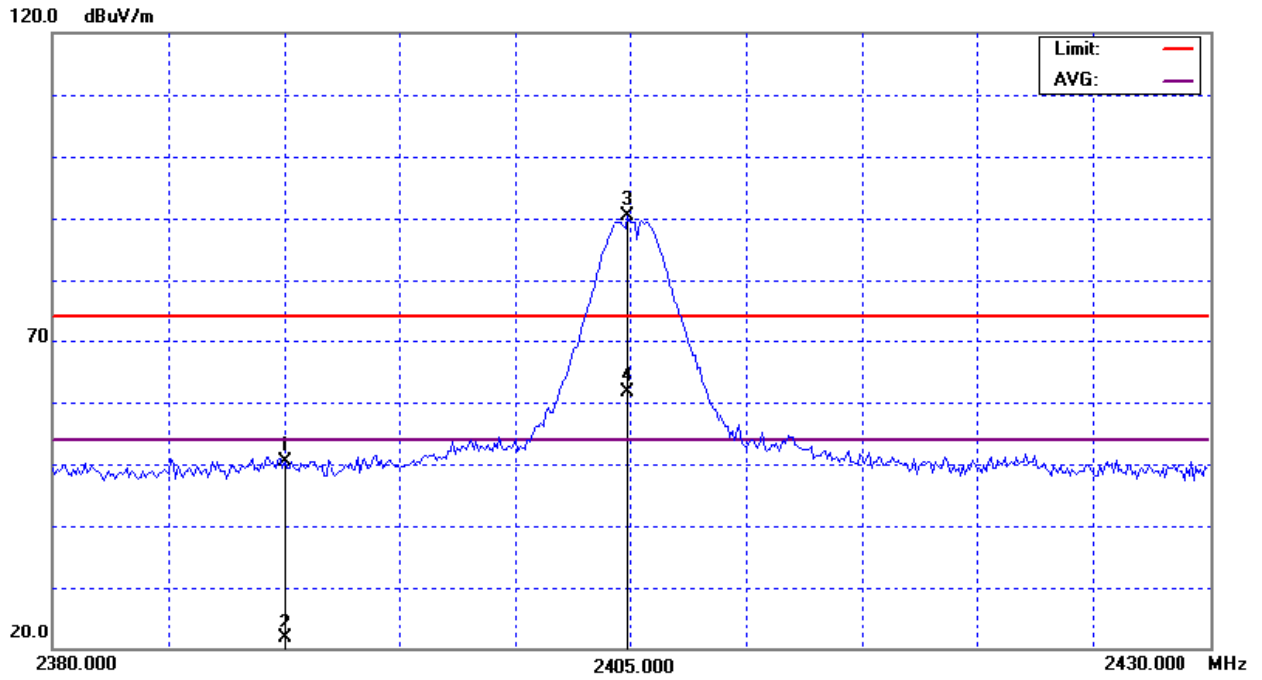

|               |                                   |                     |              |
|---------------|-----------------------------------|---------------------|--------------|
| EUT :         | IEEE 802.15.4 transceivers module | Model Name. :       | ZM100        |
| Temperature : | 24 °C                             | Relative Humidity : | 65%          |
| Pressure :    | 1016 hPa                          | Test Voltage :      | AC 120V/60Hz |
| Test Mode :   | TX 2405MHz - CH 01                |                     |              |

| Freq.<br>(MHz) | Ant.Pol.<br>H/V | Reading        |              | Ant./CF<br>CF(dB) | Act.             |                | Limit            |                | Note       |
|----------------|-----------------|----------------|--------------|-------------------|------------------|----------------|------------------|----------------|------------|
|                |                 | Peak<br>(dBuV) | AV<br>(dBuV) |                   | Peak<br>(dBuV/m) | AV<br>(dBuV/m) | Peak<br>(dBuV/m) | AV<br>(dBuV/m) |            |
| 2390.00        | H               | 22.71          | -5.99        | 32.57             | 55.28            | 26.58          | 74.00            | 54.00          | Y/E        |
| <b>2405.60</b> | <b>H</b>        | <b>61.81</b>   | <b>33.11</b> | <b>32.66</b>      | <b>94.47</b>     | <b>65.77</b>   |                  |                | <b>Y/F</b> |
| 4808.79        | H               | 46.18          | 17.48        | 3.97              | 50.15            | 21.45          | 74.00            | 54.00          | Y/H        |

Remark :

- (1) All readings are Peak unless otherwise stated QP in column of 『Note』 . Peak denotes that the Peak reading compliance with the QP Limits and then QP Mode measurement didn't perform .
- (2) Measuring frequency range from 30MHz to 1000MHz or the 10th harmonic of highest fundamental frequency . "F" denotes fundamental frequency; "H" denotes spurious frequency. "E" denotes band edge frequency. (This judgment method includes the Band Edge Requirement.)
- (3) Radiated emissions measured in frequency range above 1000MHz were made with an instrument using Peak detector mode and AV detector mode of the emission .
- (4) Data of measurement within this frequency range shown " \* " in the table above means the reading of emissions are attenuated more than 20dB below the permissible limits or the field strength is too small to be measured.
- (5) A preamp and high pass filter were used for this test in order to provide sufficient measurement sensitivity.
- (6) EUT Orthogonal Axis :  
 "X" - denotes Laid on Table ; "Y" - denotes Vertical Stand ; "Z" - denotes Side Stand
- (7) The average of fundamental frequency is Average = Peak value + 20 log (Duty cycle)  
 Where the duty factor is calculated from following formula:  
 $20 \log (\text{Duty cycle}) = 20 \log ( 1.1\text{ms}/30\text{ms}) = -28.71 \text{ dB}$   
 Please see page 36 for plotted duty

TX CH01 (Above 1000 MHz, Horizontal)

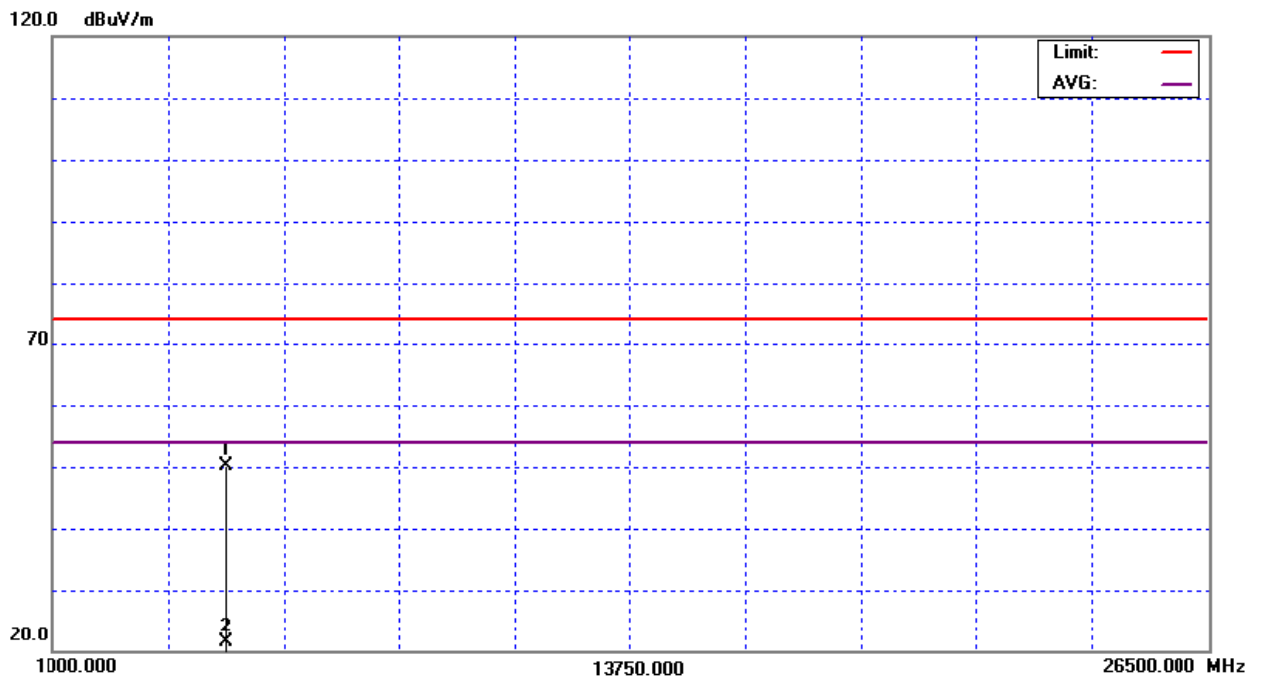
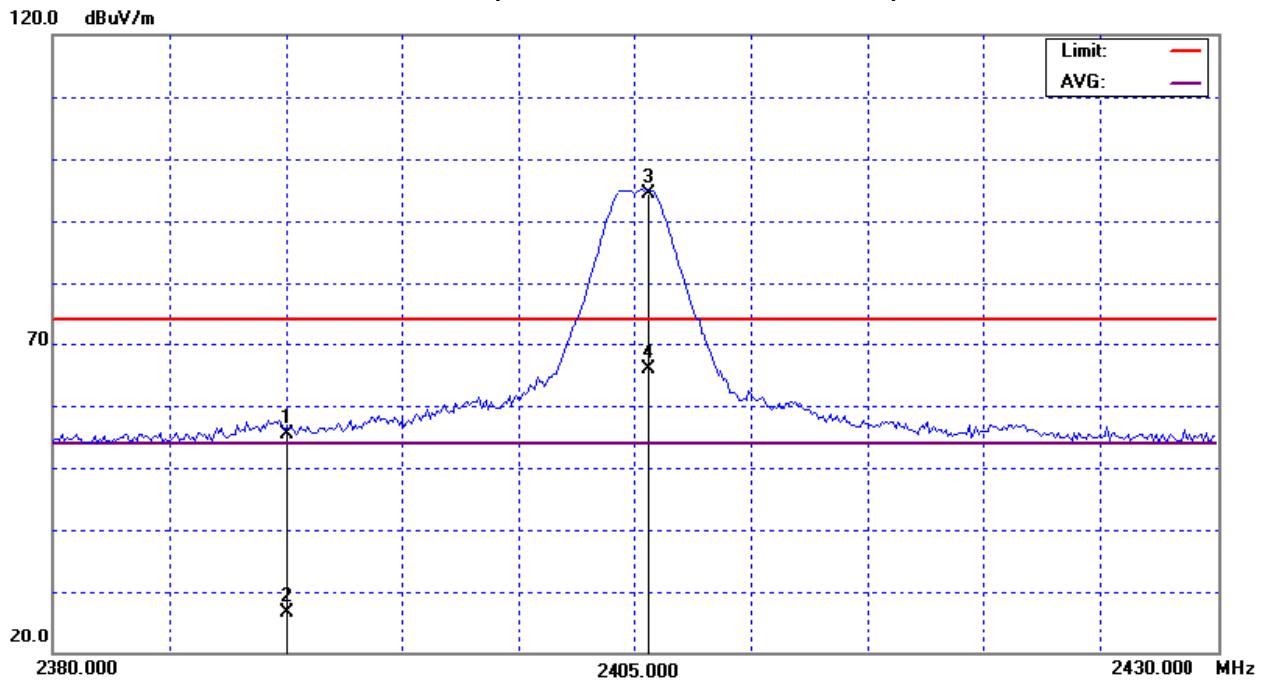

|               |                                   |                     |              |
|---------------|-----------------------------------|---------------------|--------------|
| EUT :         | IEEE 802.15.4 transceivers module | Model Name. :       | ZM100        |
| Temperature : | 24 °C                             | Relative Humidity : | 65%          |
| Pressure :    | 1016 hPa                          | Test Voltage :      | AC 120V/60Hz |
| Test Mode :   | TX 2440MHz - CH 08                |                     |              |

| Freq.          | Ant.Pol. | Reading      |              | Ant./CF      | Act.         |              | Limit    |          | Note       |
|----------------|----------|--------------|--------------|--------------|--------------|--------------|----------|----------|------------|
|                |          | Peak         | AV           |              | Peak         | AV           | Peak     | AV       |            |
| (MHz)          | H/V      | (dBuV)       | (dBuV)       | CF(dB)       | (dBuV/m)     | (dBuV/m)     | (dBuV/m) | (dBuV/m) |            |
| <b>2439.60</b> | <b>v</b> | <b>57.25</b> | <b>28.55</b> | <b>32.85</b> | <b>90.10</b> | <b>61.40</b> |          |          | <b>Y/F</b> |
| 4880.04        | V        | 48.89        | 20.19        | 4.32         | 53.21        | 24.51        | 74.00    | 54.00    | Y/H        |

Remark :

- (1) All readings are Peak unless otherwise stated QP in column of 『Note』 . Peak denotes that the Peak reading compliance with the QP Limits and then QP Mode measurement didn't perform .
- (2) Measuring frequency range from 30MHz to 1000MHz or the 10th harmonic of highest fundamental frequency . "F" denotes fundamental frequency; "H" denotes spurious frequency. "E" denotes band edge frequency. (This judgment method includes the Band Edge Requirement.)
- (3) Radiated emissions measured in frequency range above 1000MHz were made with an instrument using Peak detector mode and AV detector mode of the emission .
- (4) Data of measurement within this frequency range shown " \* " in the table above means the reading of emissions are attenuated more than 20dB below the permissible limits or the field strength is too small to be measured.
- (5) A preamp and high pass filter were used for this test in order to provide sufficient measurement sensitivity.
- (6) EUT Orthogonal Axis :  
 "X" - denotes Laid on Table ; "Y" - denotes Vertical Stand ; "Z" - denotes Side Stand
- (7) The average of fundamental frequency is Average = Peak value + 20 log (Duty cycle)  
 Where the duty factor is calculated from following formula:  
 $20 \log (\text{Duty cycle}) = 20 \log ( 1.1\text{ms}/30\text{ms}) = -28.71 \text{ dB}$   
 Please see page 36 for plotted duty

TX CH08 (Above 1000 MHz, Vertical)

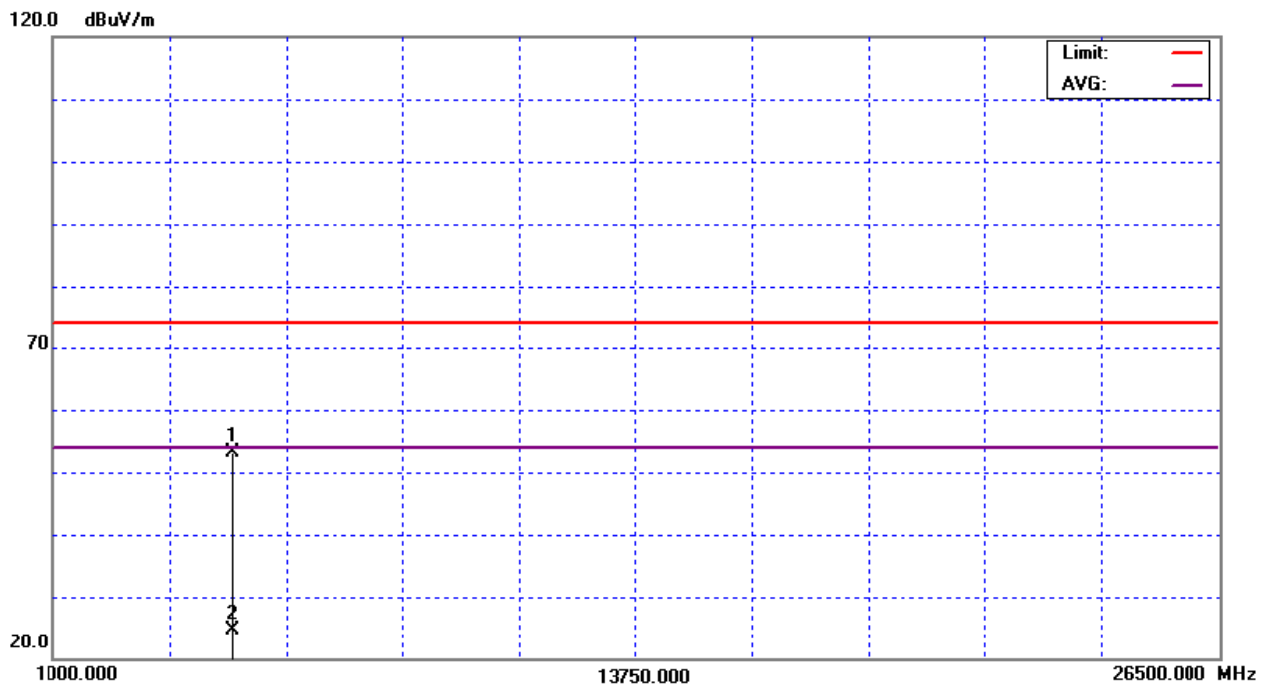
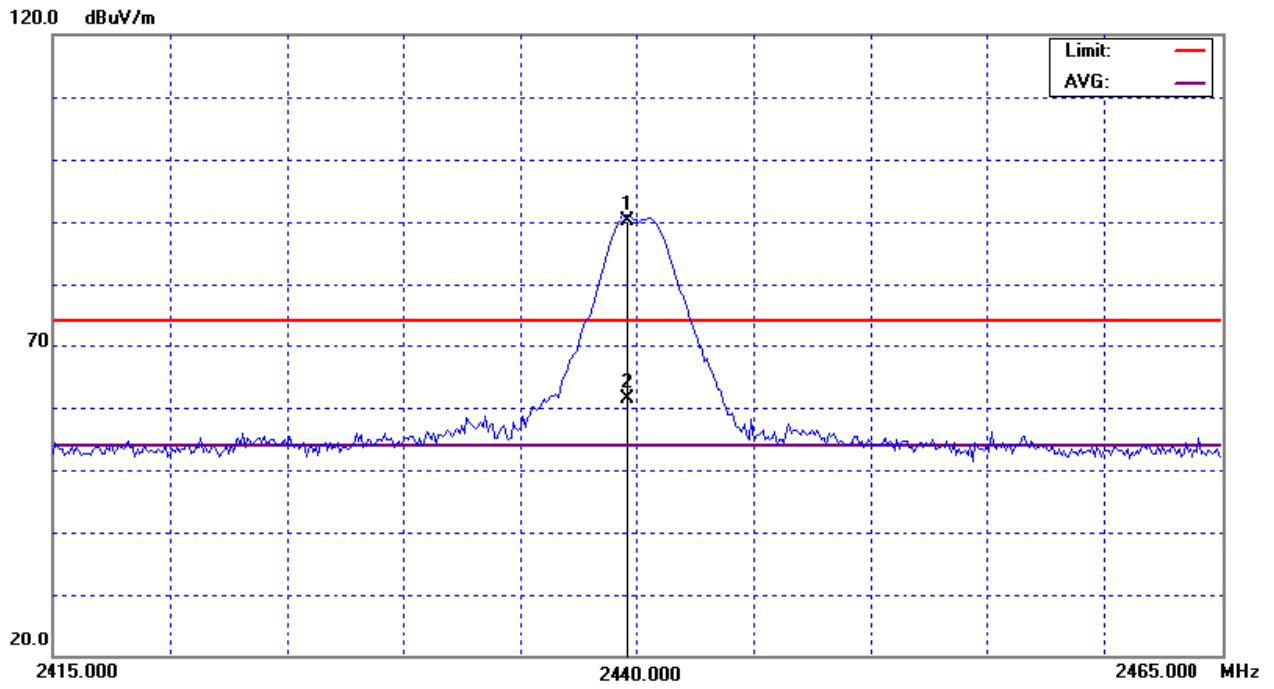

|               |                                   |                     |              |
|---------------|-----------------------------------|---------------------|--------------|
| EUT :         | IEEE 802.15.4 transceivers module | Model Name. :       | ZM100        |
| Temperature : | 24 °C                             | Relative Humidity : | 65%          |
| Pressure :    | 1016 hPa                          | Test Voltage :      | AC 120V/60Hz |
| Test Mode :   | TX 2440MHz –CH 08                 |                     |              |

| Freq.          | Ant.Pol. | Reading      |              | Ant./CF      | Act.         |              | Limit    |          | Note       |
|----------------|----------|--------------|--------------|--------------|--------------|--------------|----------|----------|------------|
|                |          | Peak         | AV           |              | Peak         | AV           | Peak     | AV       |            |
| (MHz)          | H/V      | (dBuV)       | (dBuV)       | CF(dB)       | (dBuV/m)     | (dBuV/m)     | (dBuV/m) | (dBuV/m) |            |
| <b>2440.50</b> | <b>H</b> | <b>60.24</b> | <b>51.41</b> | <b>32.86</b> | <b>93.10</b> | <b>84.27</b> |          |          | <b>Y/F</b> |
| 4880.12        | H        | 45.83        | 17.13        | 4.32         | 50.15        | 21.45        | 74.00    | 54.00    | Y/H        |

Remark :

- (1) All readings are Peak unless otherwise stated QP in column of 『Note』 . Peak denotes that the Peak reading compliance with the QP Limits and then QP Mode measurement didn't perform .
- (2) Measuring frequency range from 30MHz to 1000MHz or the 10th harmonic of highest fundamental frequency °“F” denotes fundamental frequency; “H” denotes spurious frequency. “E” denotes band edge frequency. (This judgment method includes the Band Edge Requirement.)
- (3) Radiated emissions measured in frequency range above 1000MHz were made with an instrument using Peak detector mode and AV detector mode of the emission .
- (4) Data of measurement within this frequency range shown “ \* ” in the table above means the reading of emissions are attenuated more than 20dB below the permissible limits or the field strength is too small to be measured.
- (5) A preamp and high pass filter were used for this test in order to provide sufficient measurement sensitivity.
- (6) EUT Orthogonal Axis :  
 “X” - denotes Laid on Table ; “Y” - denotes Vertical Stand ; “Z” - denotes Side Stand
- (7) The average of fundamental frequency is Average = Peak value + 20 log (Duty cycle)  
 Where the duty factor is calculated from following formula:  
 $20 \log (\text{Duty cycle}) = 20 \log ( 1.1\text{ms}/30\text{ms}) = -28.71 \text{ dB}$   
 Please see page 36 for plotted duty

TX CH08 (Above 1000 MHz, Horizontal)

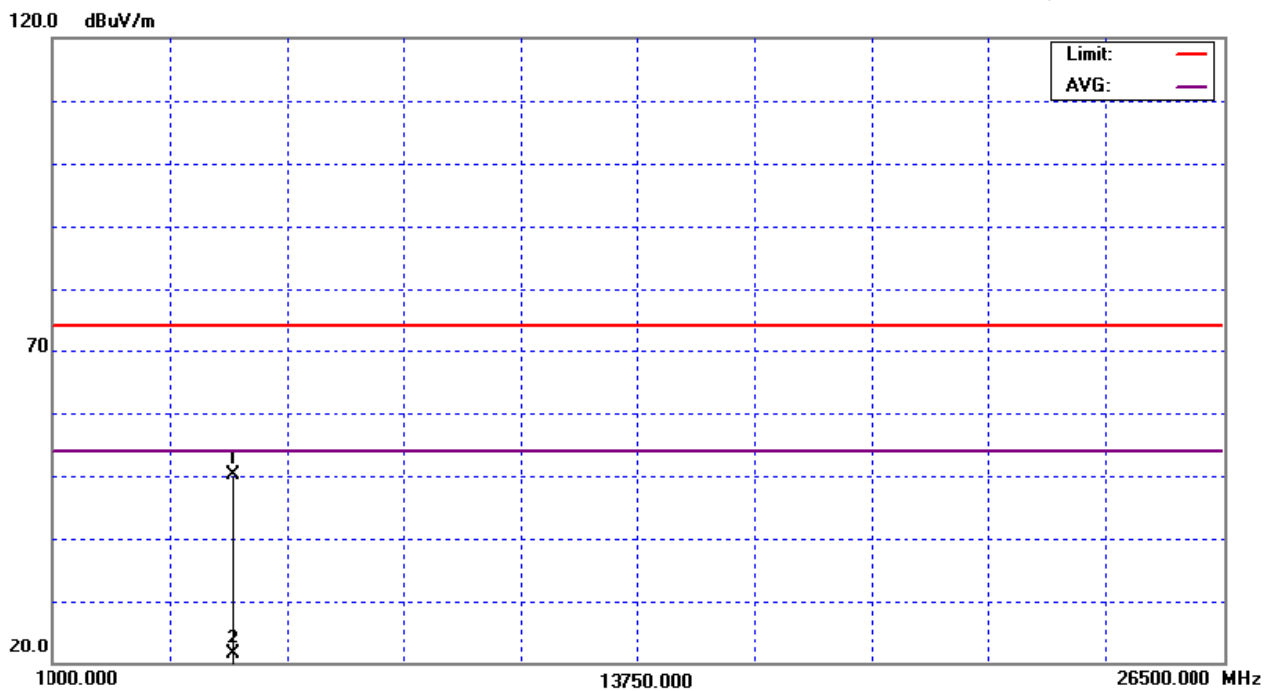
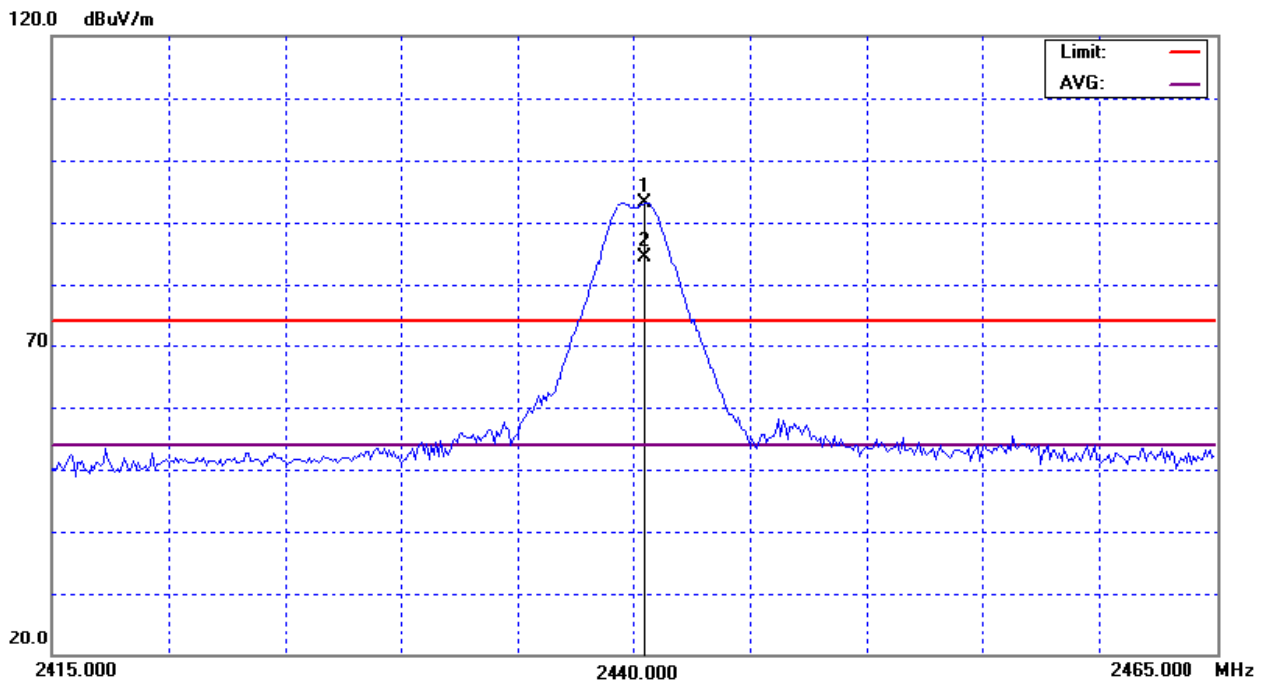

|               |                                   |                     |              |
|---------------|-----------------------------------|---------------------|--------------|
| EUT :         | IEEE 802.15.4 transceivers module | Model Name. :       | ZM100        |
| Temperature : | 24 °C                             | Relative Humidity : | 65%          |
| Pressure :    | 1016 hPa                          | Test Voltage :      | AC 120V/60Hz |
| Test Mode :   | TX 2480MHz –CH 16                 |                     |              |

| Freq.          | Ant.Pol. | Reading      |              | Ant./CF      | Act.         |              | Limit    |          | Note       |
|----------------|----------|--------------|--------------|--------------|--------------|--------------|----------|----------|------------|
|                |          | Peak         | AV           |              | Peak         | AV           | Peak     | AV       |            |
| (MHz)          | H/V      | (dBuV)       | (dBuV)       | CF(dB)       | (dBuV/m)     | (dBuV/m)     | (dBuV/m) | (dBuV/m) |            |
| <b>2480.50</b> | <b>V</b> | <b>57.34</b> | <b>28.64</b> | <b>33.08</b> | <b>90.42</b> | <b>61.72</b> |          |          | <b>Y/F</b> |
| 2483.50        | V        | 26.23        | -2.47        | 33.10        | 59.33        | 30.63        | 74.00    | 54.00    | Y/E        |
| 4960.24        | V        | 48.76        | 20.06        | 4.71         | 53.47        | 24.77        | 74.00    | 54.00    | Y/H        |

Remark :

- (1) All readings are Peak unless otherwise stated QP in column of 『Note』 . Peak denotes that the Peak reading compliance with the QP Limits and then QP Mode measurement didn't perform .
- (2) Measuring frequency range from 30MHz to 1000MHz or the 10th harmonic of highest fundamental frequency . "F" denotes fundamental frequency; "H" denotes spurious frequency. "E" denotes band edge frequency. (This judgment method includes the Band Edge Requirement.)
- (3) Radiated emissions measured in frequency range above 1000MHz were made with an instrument using Peak detector mode and AV detector mode of the emission .
- (4) Data of measurement within this frequency range shown " \* " in the table above means the reading of emissions are attenuated more than 20dB below the permissible limits or the field strength is too small to be measured.
- (5) A preamp and high pass filter were used for this test in order to provide sufficient measurement sensitivity.
- (6) EUT Orthogonal Axis :  
 "X" - denotes Laid on Table ; "Y" - denotes Vertical Stand ; "Z" - denotes Side Stand
- (7) The average of fundamental frequency is Average = Peak value + 20 log (Duty cycle)  
 Where the duty factor is calculated from following formula:  
 $20 \log (\text{Duty cycle}) = 20 \log ( 1.1\text{ms}/30\text{ms}) = -28.71 \text{ dB}$   
 Please see page 36 for plotted duty



TX CH16 (Above 1000 MHz, Vertical)

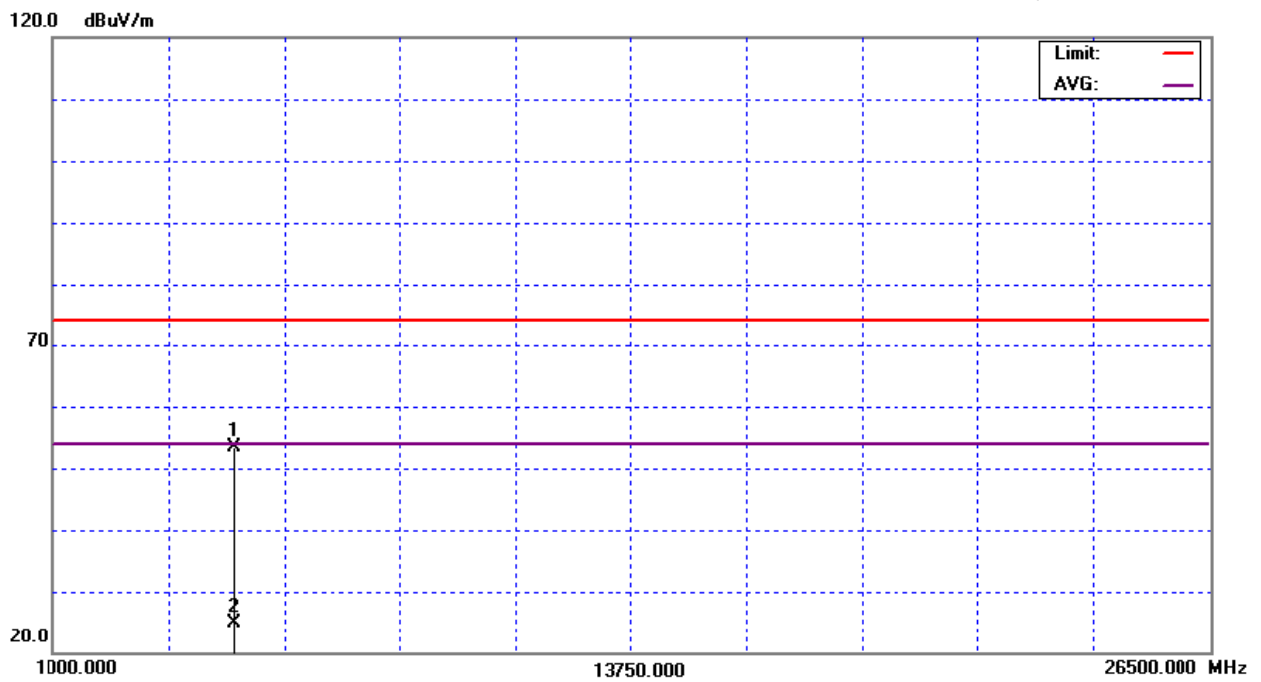
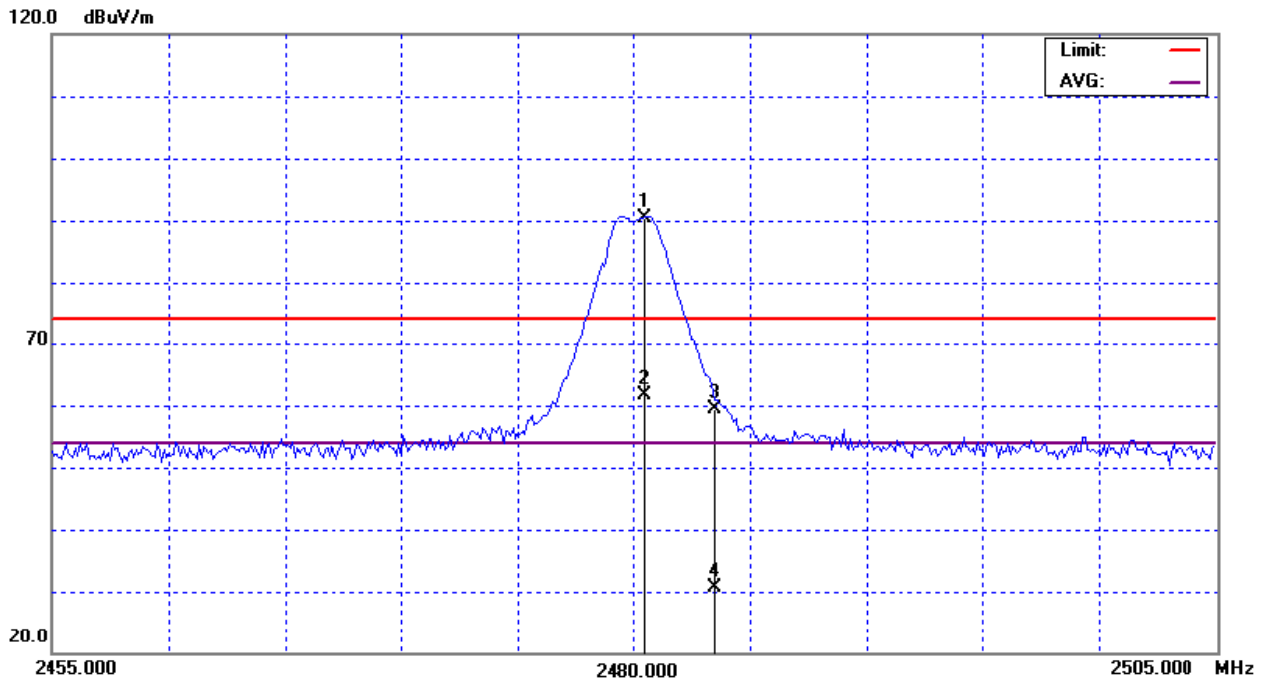

|               |                                   |                     |              |
|---------------|-----------------------------------|---------------------|--------------|
| EUT :         | IEEE 802.15.4 transceivers module | Model Name. :       | ZM100        |
| Temperature : | 24 °C                             | Relative Humidity : | 65%          |
| Pressure :    | 1016 hPa                          | Test Voltage :      | AC 120V/60Hz |
| Test Mode :   | TX 2480MHz - CH 16                |                     |              |

| Freq.          | Ant.Pol. | Reading      |              | Ant./CF      | Act.         |              | Limit    |          | Note       |
|----------------|----------|--------------|--------------|--------------|--------------|--------------|----------|----------|------------|
|                |          | Peak         | AV           |              | Peak         | AV           | Peak     | AV       |            |
| (MHz)          | H/V      | (dBuV)       | (dBuV)       | CF(dB)       | (dBuV/m)     | (dBuV/m)     | (dBuV/m) | (dBuV/m) |            |
| <b>2479.80</b> | <b>H</b> | <b>59.79</b> | <b>31.09</b> | <b>33.08</b> | <b>92.87</b> | <b>64.17</b> |          |          | <b>Y/F</b> |
| 2483.50        | H        | 29.43        | 0.73         | 33.10        | 62.53        | 33.83        | 74.00    | 54.00    | Y/E        |
| 4959.02        | H        | 46.40        | 17.70        | 4.71         | 51.11        | 22.41        | 74.00    | 54.00    | Y/H        |

Remark :

- (1) All readings are Peak unless otherwise stated QP in column of 『Note』 . Peak denotes that the Peak reading compliance with the QP Limits and then QP Mode measurement didn't perform .
- (2) Measuring frequency range from 30MHz to 1000MHz or the 10th harmonic of highest fundamental frequency . "F" denotes fundamental frequency; "H" denotes spurious frequency. "E" denotes band edge frequency. (This judgment method includes the Band Edge Requirement.)
- (3) Radiated emissions measured in frequency range above 1000MHz were made with an instrument using Peak detector mode and AV detector mode of the emission .
- (4) Data of measurement within this frequency range shown " \* " in the table above means the reading of emissions are attenuated more than 20dB below the permissible limits or the field strength is too small to be measured.
- (5) A preamp and high pass filter were used for this test in order to provide sufficient measurement sensitivity.
- (6) EUT Orthogonal Axis :  
 "X" - denotes Laid on Table ; "Y" - denotes Vertical Stand ; "Z" - denotes Side Stand
- (7) The average of fundamental frequency is Average = Peak value + 20 log (Duty cycle)  
 Where the duty factor is calculated from following formula:  
 $20 \log (\text{Duty cycle}) = 20 \log ( 1.1\text{ms}/30\text{ms}) = -28.71 \text{ dB}$   
 Please see page 36 for plotted duty

TX CH16 (Above 1000 MHz, Horizontal)

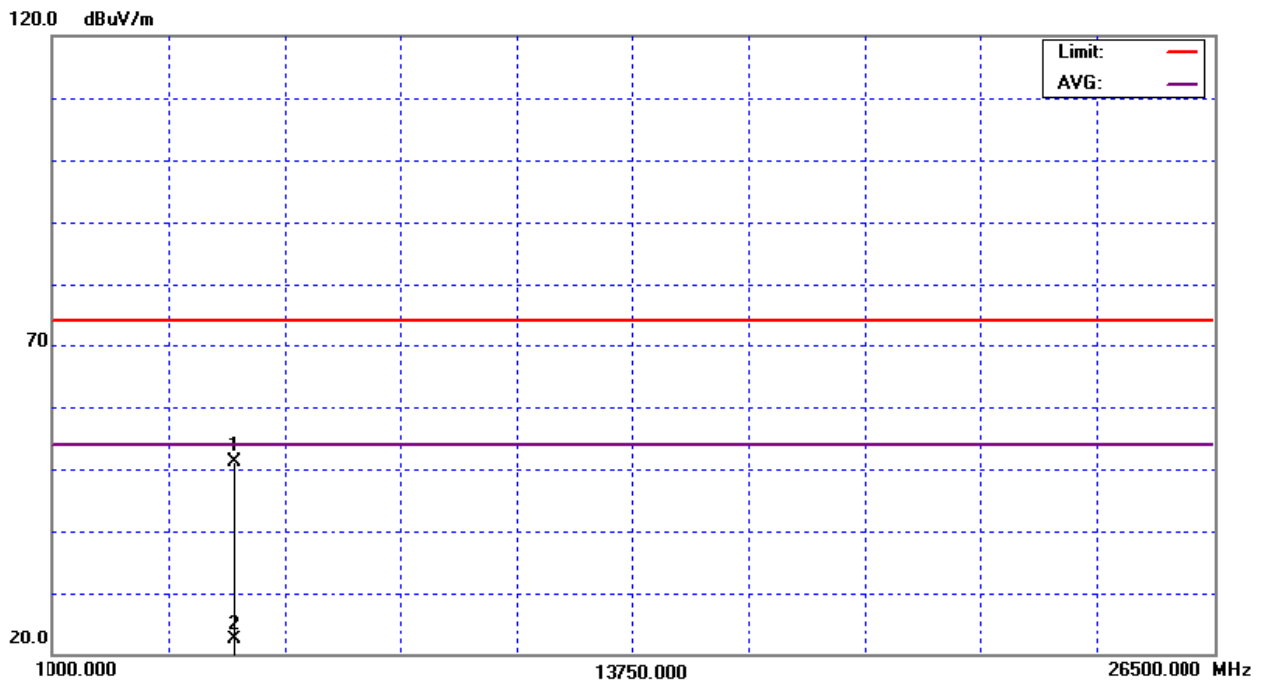
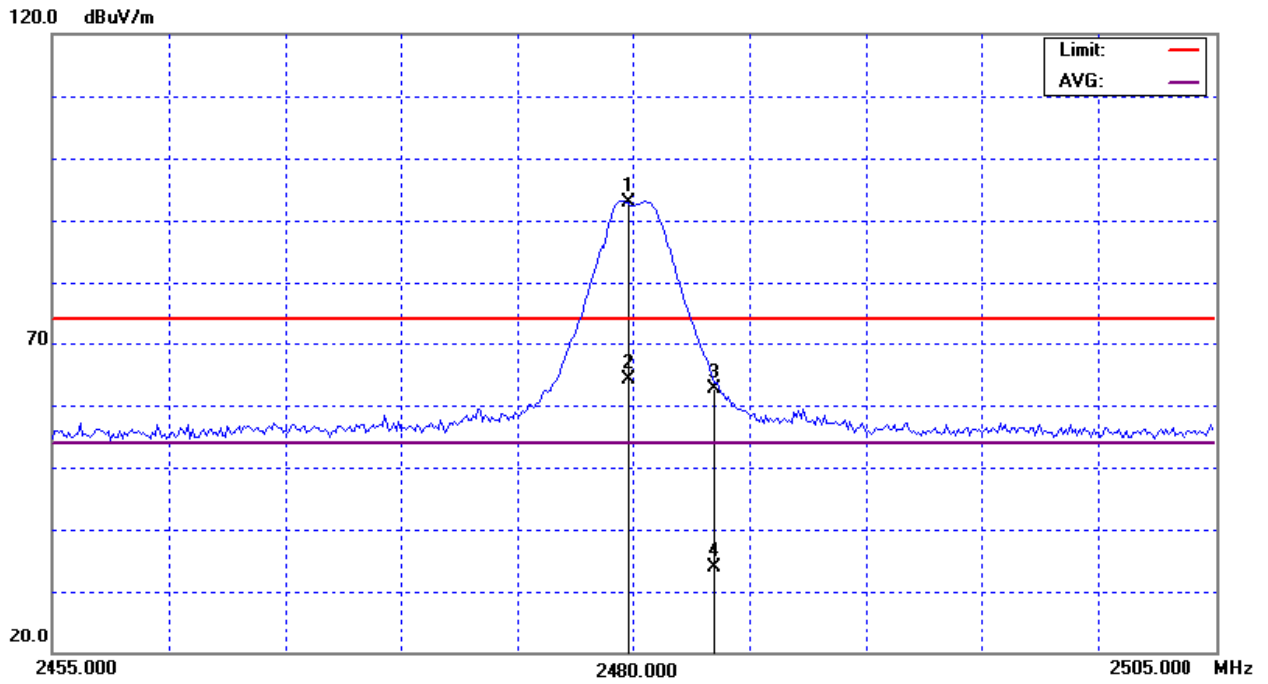

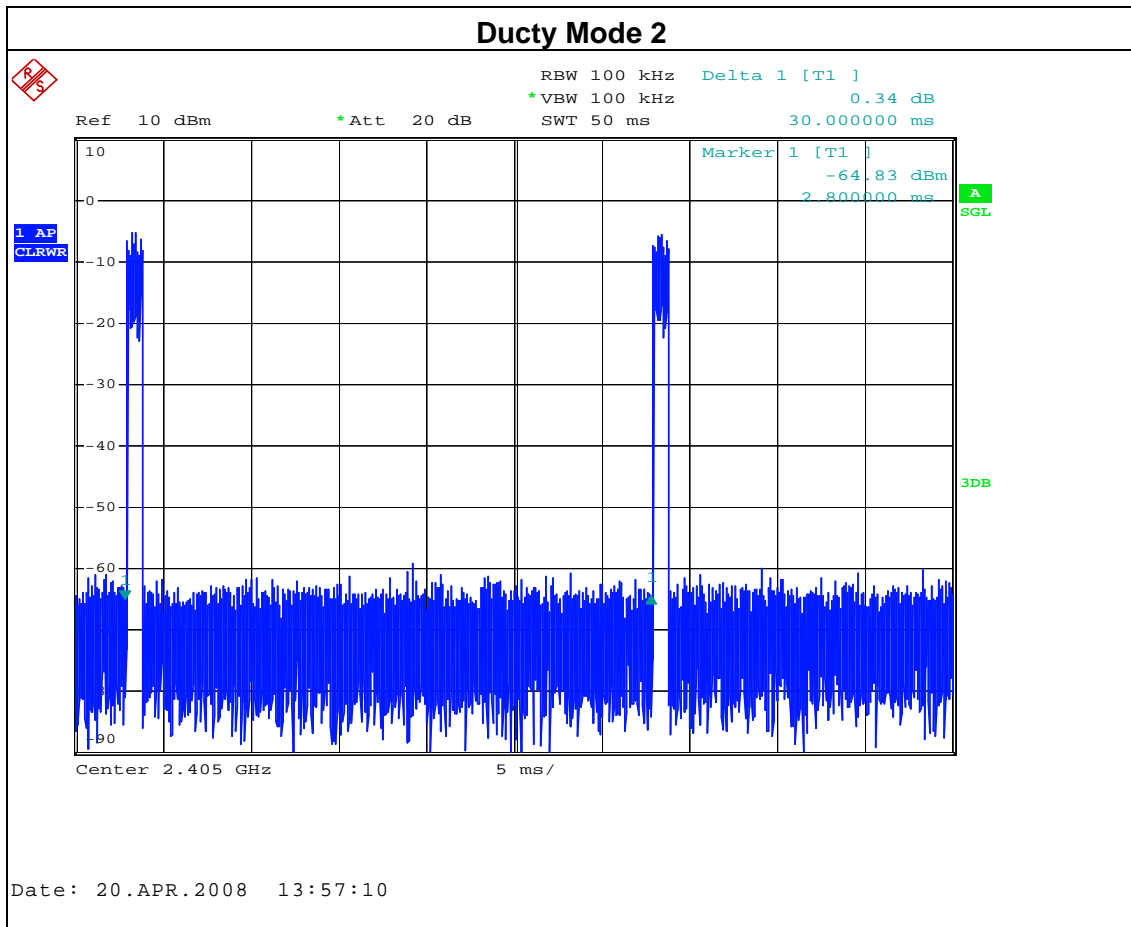
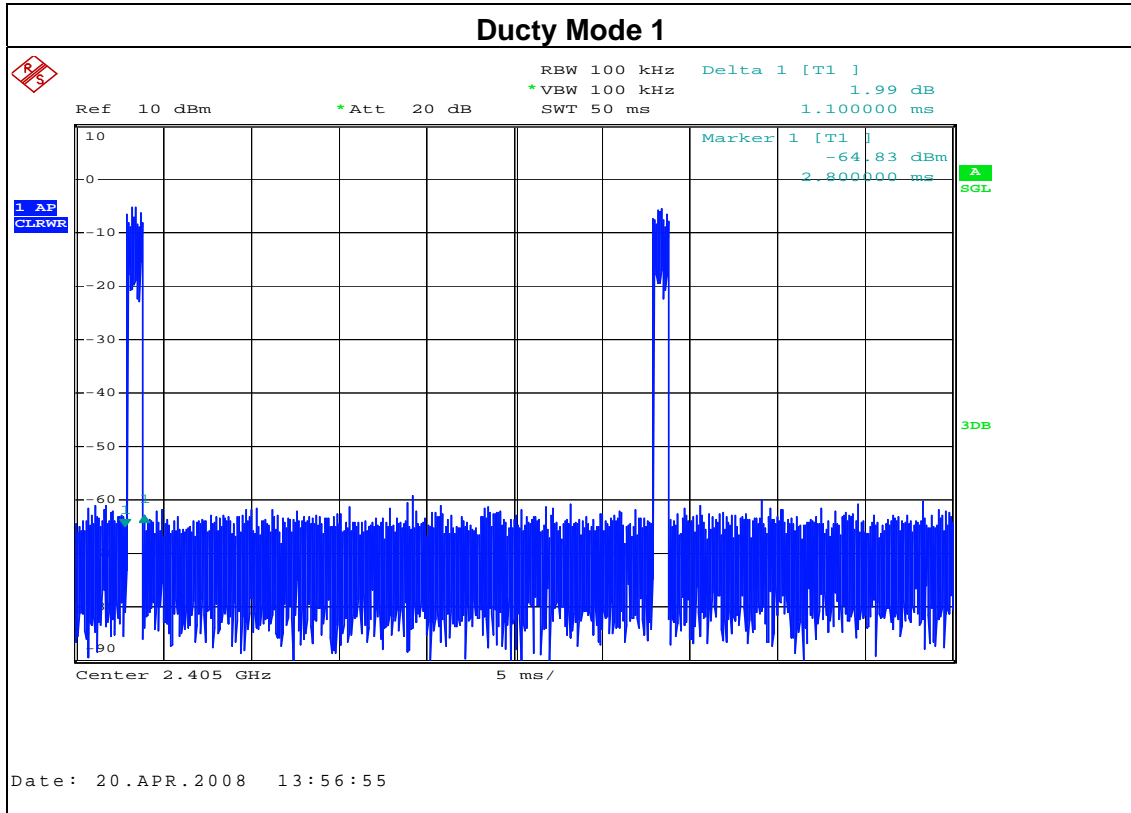

**4.2.9 TEST RESULTS (RESTRICTED BANDS REQUIREMENTS)**

|               |   |                     |              |
|---------------|---|---------------------|--------------|
| EUT :         | IEEE 802.15.4 transceivers module   | Model Name. :       | ZM100        |
| Temperature : | 24 °C   | Relative Humidity : | 65%          |
| Pressure :    | 1016 hPa  | Test Voltage :      | AC 120V/60Hz |
| Test Mode :   | TX 2405MHz/2480MHz (Vertical)   |                     |              |
| Note :        | 1. The transmitter was setup to transmit at the lowest channel (CH01). Then the field strength was measured at 2310-2390 MHz.<br>2. The transmitter was setup to transmit at the highest channel (CH16). Then the field strength was measured at 2483.5-2500 MHz. |                     |              |

| Freq.   | Ant.Pol. | Reading |        | Ant./CF | Act.     |          | Limit    |          | Note |
|---------|----------|---------|--------|---------|----------|----------|----------|----------|------|
|         |          | Peak    | AV     |         | Peak     | AV       | Peak     | AV       |      |
| (MHz)   | H/V      | (dBuV)  | (dBuV) | CF(dB)  | (dBuV/m) | (dBuV/m) | (dBuV/m) | (dBuV/m) |      |
| 2390.00 | V        | 17.81   | -10.89 | 32.57   | 50.38    | 21.68    | 74.00    | 54.00    | CH01 |
| 2483.50 | V        | 26.23   | -2.47  | 33.10   | 59.33    | 30.63    | 74.00    | 54.00    | CH16 |

Remark :

- (1) Radiated emissions measured in frequency range above 1000MHz were made with an instrument using Peak detector mode and AV detector mode of the emission .
- (2) EUT Orthogonal Axis :  
 "X" - denotes Laid on Table ; "Y" - denotes Vertical Stand ; "Z" - denotes Side Stand

Restricted Bands Requirements, Vertical  
CH01

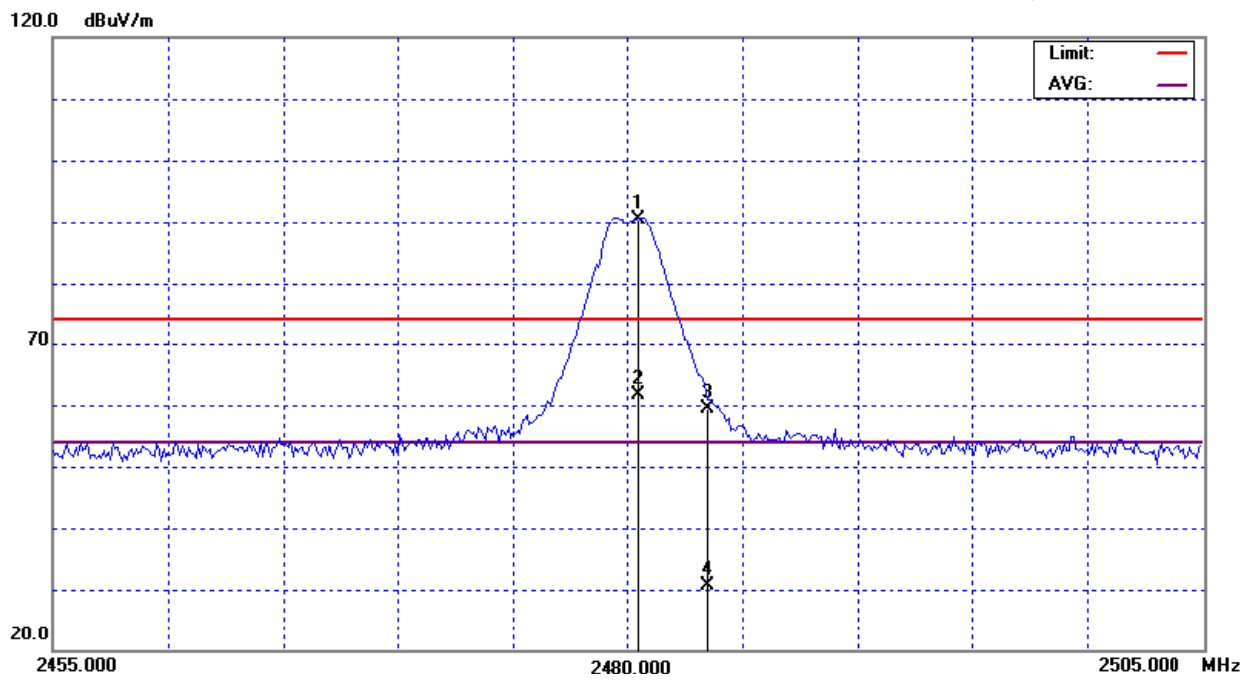
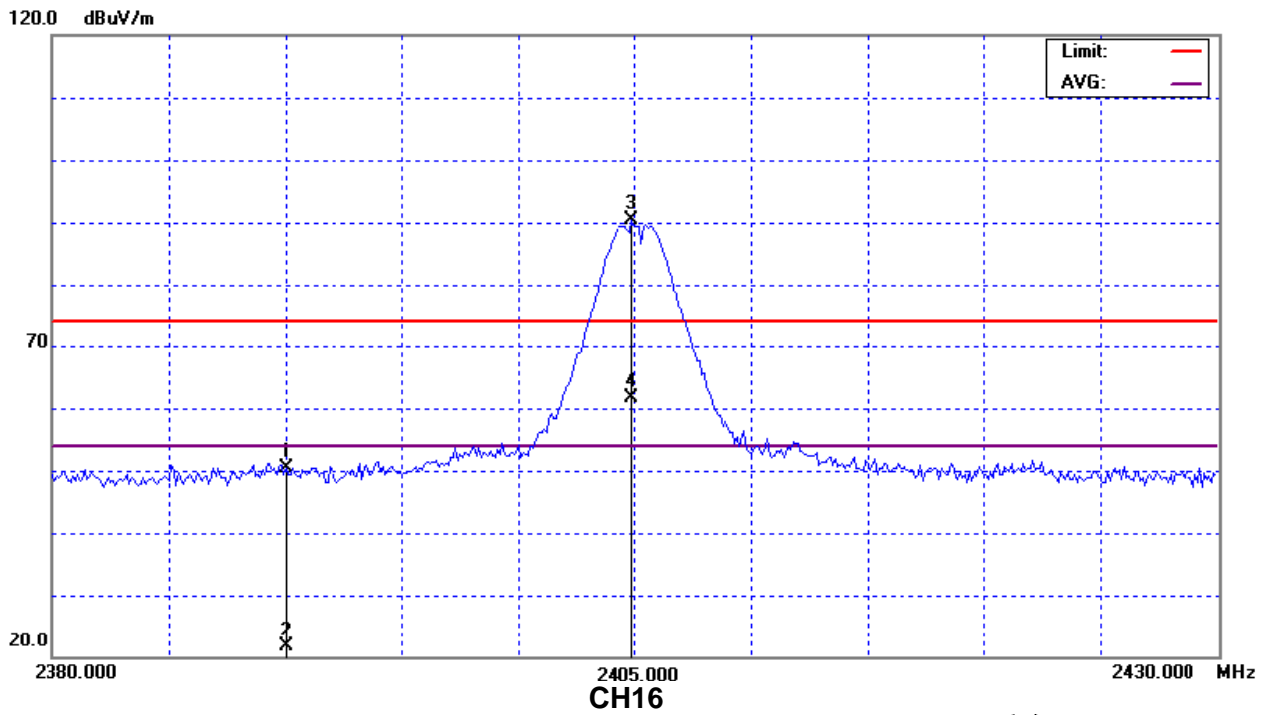

|               |   |                     |              |
|---------------|---|---------------------|--------------|
| EUT :         | IEEE 802.15.4 transceivers module   | Model Name. :       | ZM100        |
| Temperature : | 24 °C   | Relative Humidity : | 65%          |
| Pressure :    | 1016 hPa  | Test Voltage :      | AC 120V/60Hz |
| Test Mode :   | TX 2405MHz/2480MHz (Horizontal)   |                     |              |
| Note :        | 1. The transmitter was setup to transmit at the lowest channel (CH01). Then the field strength was measured at 2310-2390 MHz.<br>2. The transmitter was setup to transmit at the highest channel (CH16). Then the field strength was measured at 2483.5-2500 MHz. |                     |              |

| Freq.<br>(MHz) | Ant.Pol.<br>H/V | Reading        |              | Ant./CF<br>CF(dB) | Act.             |                | Limit            |                | Note |
|----------------|-----------------|----------------|--------------|-------------------|------------------|----------------|------------------|----------------|------|
|                |                 | Peak<br>(dBuV) | AV<br>(dBuV) |                   | Peak<br>(dBuV/m) | AV<br>(dBuV/m) | Peak<br>(dBuV/m) | AV<br>(dBuV/m) |      |
| 2390.00        | H               | 22.71          | -5.99        | 32.57             | 55.28            | 26.58          | 74.00            | 54.00          | CH01 |
| 2483.50        | H               | 29.43          | 0.73         | 33.10             | 62.53            | 33.83          | 74.00            | 54.00          | CH16 |

Remark :

- (1) Radiated emissions measured in frequency range above 1000MHz were made with an instrument using Peak detector mode and AV detector mode of the emission .
- (2) EUT Orthogonal Axis :  
 "X" - denotes Laid on Table ; "Y" - denotes Vertical Stand ; "Z" - denotes Side Stand

Restricted Bands Requirements, Horizontal  
CH01

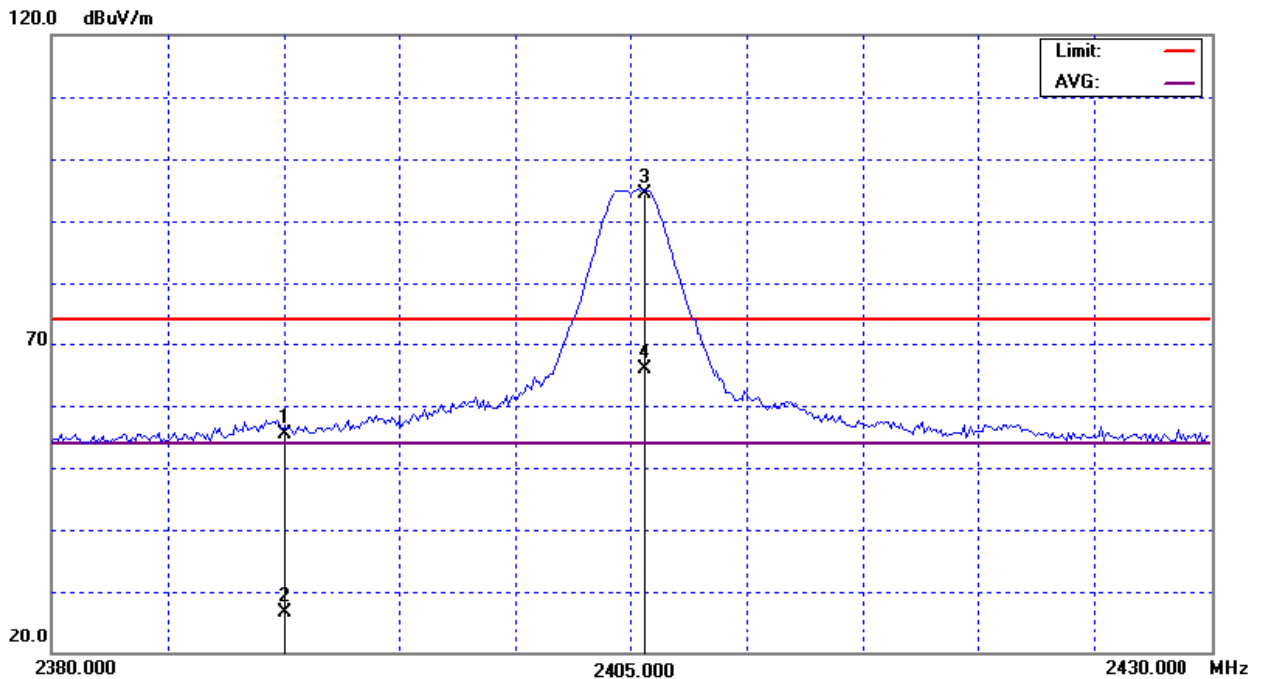

CH16

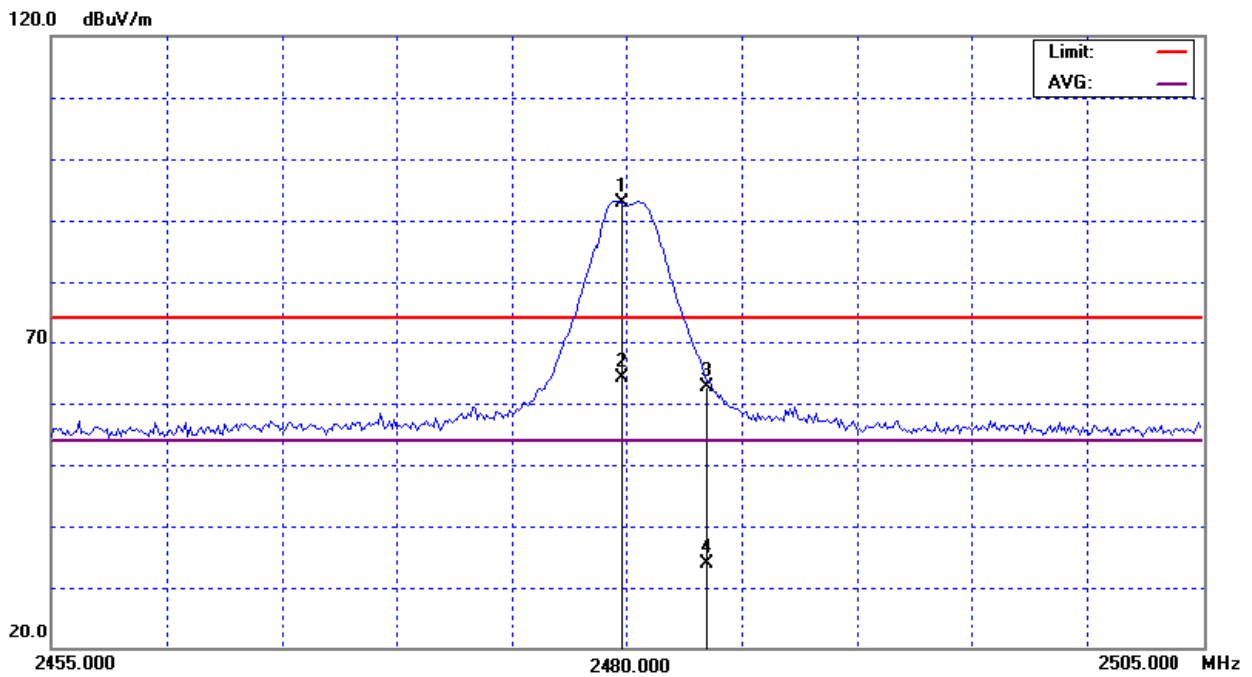



**5. BANDWIDTH TEST**

**5.1 Applied procedures / limit**

| FCC Part15 (15.247) , Subpart C |           |                              |                       |        |
|---------------------------------|-----------|------------------------------|-----------------------|--------|
| Section                         | Test Item | Limit                        | Frequency Range (MHz) | Result |
| 15.247<br>(a)(2)                | Bandwidth | >= 500KHz<br>(6dB bandwidth) | 2400-2483.5           | PASS   |

**5.1.1 MEASUREMENT INSTRUMENTS LIST**

| Item | Kind of Equipment | Manufacturer | Type No. | Serial No. | Calibrated until |
|------|-------------------|--------------|----------|------------|------------------|
| 1    | Spectrum Analyzer | R&S          | FSP_40   | 100129     | Aug. 16, 2008    |

Remark: " N/A" denotes No Model Name. , Serial No. or No Calibration specified.

**5.1.2 TEST PROCEDURE**

- a. The EUT was directly connected to the spectrum analyzer and antenna output port as show in the block diagram below,
- b. Spectrum Setting : RBW= 100KHz, VBW=100KHz, Sweep time = 20 ms.

**5.1.3 DEVIATION FROM STANDARD**

No deviation.

**5.1.4 TEST SETUP**

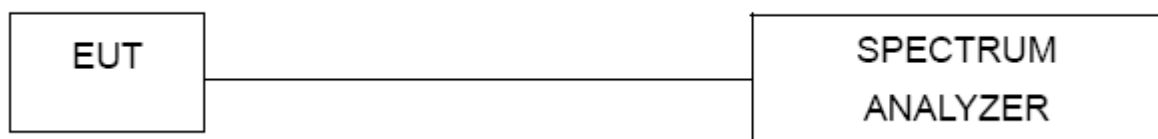

**5.1.5 EUT OPERATION CONDITIONS**

The EUT tested system was configured as the statements of 4.1.6 Unless otherwise a special operating condition is specified in the follows during the testing.

5.1.6 TEST RESULTS

|               |                                   |                     |              |
|---------------|-----------------------------------|---------------------|--------------|
| EUT :         | IEEE 802.15.4 transceivers module | Model Name. :       | ZM100        |
| Temperature : | 24 °C                             | Relative Humidity : | 65%          |
| Pressure :    | 1016 hPa                          | Test Voltage :      | AC 120V/60Hz |
| Test Mode :   | Zigbee mode /CH01, CH08, CH16     |                     |              |

| Test Channel | Frequency (MHz) | Bandwidth (MHz) | 99% Occupied BW (MHz) | LIMIT (MHz) |
|--------------|-----------------|-----------------|-----------------------|-------------|
| CH01         | 2405            | 1.59            | 2.40                  | >=500KHz    |
| CH08         | 2440            | 1.58            | 2.39                  | >=500KHz    |
| CH16         | 2480            | 1.58            | 2.39                  | >=500KHz    |

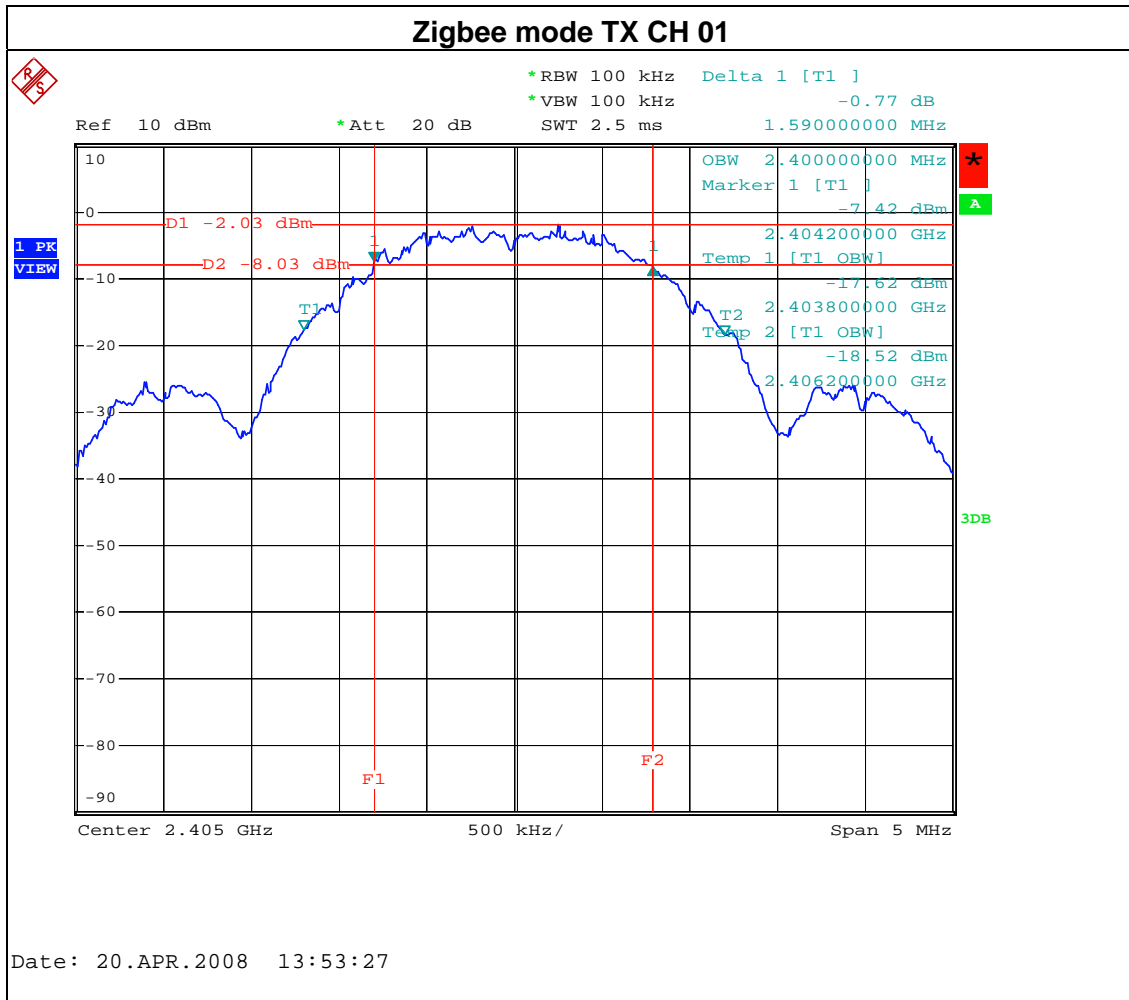

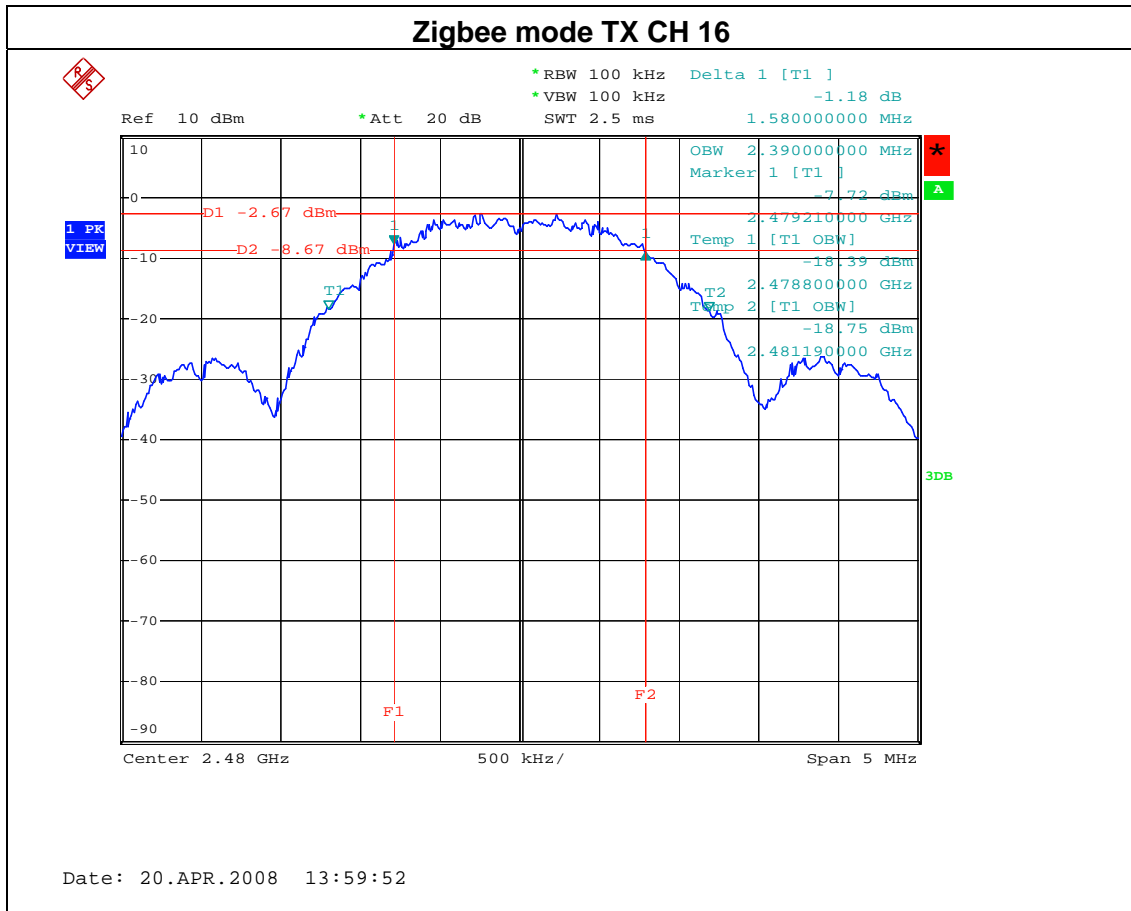
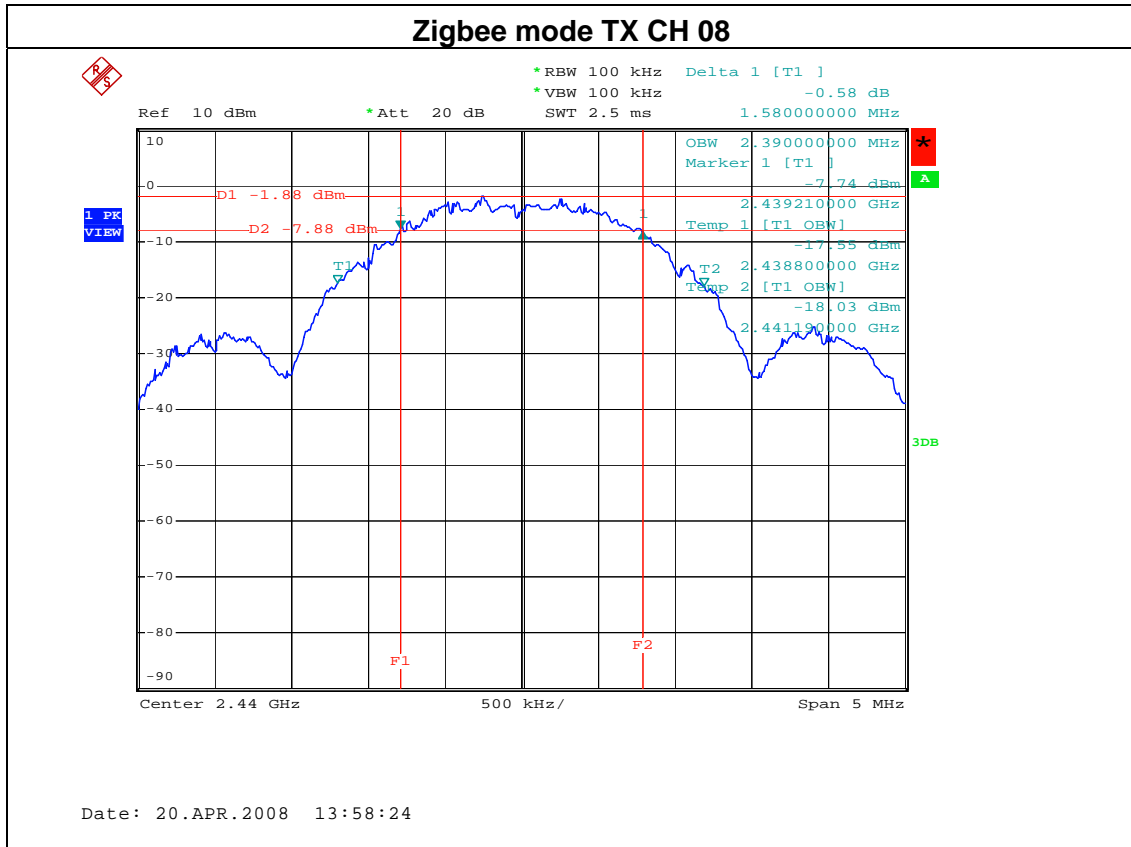

**6. PEAK OUTPUT POWER TEST**

**6.1 Applied procedures / limit**

| FCC Part15 (15.247) , Subpart C |                   |                 |                       |        |
|---------------------------------|-------------------|-----------------|-----------------------|--------|
| Section                         | Test Item         | Limit           | Frequency Range (MHz) | Result |
| 15.247 (b)(1)                   | Peak Output Power | 1 watt or 30dBm | 2400-2483.5           | PASS   |

**6.1.1 MEASUREMENT INSTRUMENTS LIST**

| Item | Kind of Equipment  | Manufacturer | Type No. | Serial No. | Calibrated until |
|------|--------------------|--------------|----------|------------|------------------|
| 1    | Power Meter        | Anritsu      | ML2487A  | 6K00004714 | Feb. 12, 2009    |
| 2    | Power Meter Sensor | Anritsu      | MA2491A  | 34138      | Feb. 12, 2009    |

Remark: " N/A" denotes No Model Name. , Serial No. or No Calibration specified.

**6.1.2 TEST PROCEDURE**

- a. The EUT was directly connected to the spectrum analyzer and antenna output port as show in the block diagram below,
- b. Spectrum Setting : RBW= 3MHz, VBW= 3MHz, Sweep time = 20 ms.

**6.1.3 DEVIATION FROM STANDARD**

No deviation.

**6.1.4 TEST SETUP**

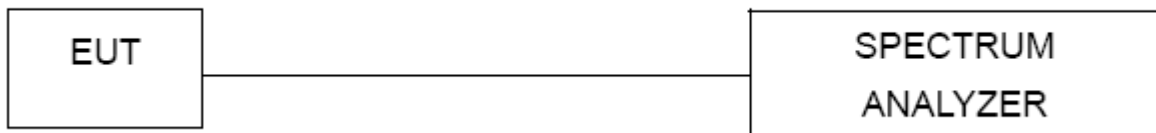

**6.1.5 EUT OPERATION CONDITIONS**

The EUT tested system was configured as the statements of 4.1.6 Unless otherwise a special operating condition is specified in the follows during the testing.

6.1.6 TEST RESULTS

|               |                                   |                     |              |
|---------------|-----------------------------------|---------------------|--------------|
| EUT :         | IEEE 802.15.4 transceivers module | Model Name. :       | ZM100        |
| Temperature : | 24 °C                             | Relative Humidity : | 65%          |
| Pressure :    | 1016 hPa                          | Test Voltage :      | AC 120V/60Hz |
| Test Mode :   | Zigbee mode /CH01, CH08, CH16     |                     |              |

| Test Channel | Frequency (MHz) | Peak Output Power (dBm) | LIMIT (dBm) | LIMIT (W) |
|--------------|-----------------|-------------------------|-------------|-----------|
| CH01         | 2405            | 1.32                    | 30          | 1         |
| CH08         | 2440            | 1.24                    | 30          | 1         |
| CH16         | 2480            | 1.06                    | 30          | 1         |

**7. ANTENNA CONDUCTED SPURIOUS EMISSION**

**7.1 Applied procedures / limit**

20dBc in any 100 kHz bandwidth outside the operating frequency band. In case the emission fall within the restricted band specified on 15.205(a), then the 15.209(a) limit in the table below has to be followed.

| Frequencies (MHz) | Field Strength (micovolts/meter) | Measurement Distance (meters) |
|-------------------|----------------------------------|-------------------------------|
| 0.009~0.490       | 2400/F(KHz)                      | 300                           |
| 0.490~1.705       | 24000/F(KHz)                     | 30                            |
| 1.705~30.0        | 30                               | 30                            |
| 30~88             | 100                              | 3                             |
| 88~216            | 150                              | 3                             |
| 216~960           | 200                              | 3                             |
| Above 960         | 500                              | 3                             |

**7.1.1 MEASUREMENT INSTRUMENTS LIST**

| Item | Kind of Equipment | Manufacturer | Type No. | Serial No. | Calibrated until |
|------|-------------------|--------------|----------|------------|------------------|
| 1    | Spectrum Analyzer | R&S          | FSP_40   | 100129     | Aug. 16, 2008    |

Remark: " N/A" denotes No Model Name. , Serial No. or No Calibration specified.

The following table is the setting of the spectrum analyzer.

| Spectrum Parameter                    | Setting  |
|---------------------------------------|--|
| Attenuation                           | Auto   |
| Span Frequency                        | 100 MHz  |
| RB / VB (emission in restricted band) | 1MHz / 1MHz for Peak, 1 MHz / 10Hz for Average |
| RB / VB (other emission)              | 100 KHz /100 KHz for Peak                      |

**7.1.2 TEST PROCEDURE**

- a. The EUT was directly connected to the spectrum analyzer and antenna output port as show in the block diagram below,
- b. Spectrum Setting : RBW= 100KHz, VBW=100KHz, Sweep time = 200 ms.

**7.1.3 DEVIATION FROM STANDARD**

No deviation.

**7.1.4 TEST SETUP**



#### **7.1.5 EUT OPERATION CONDITIONS**

The EUT tested system was configured as the statements of 4.1.6 Unless otherwise a special operating condition is specified in the follows during the testing.

**7.1.6 TEST RESULTS**

|               |                                   |                     |              |
|---------------|-----------------------------------|---------------------|--------------|
| EUT :         | IEEE 802.15.4 transceivers module | Model Name. :       | ZM100        |
| Temperature : | 24 °C                             | Relative Humidity : | 65%          |
| Pressure :    | 1016 hPa                          | Test Voltage :      | AC 120V/60Hz |
| Test Mode :   | Zigbee mode CH01, CH16            |                     |              |

| Channel of Worst Data: CH16   |            |  |            |
|---|------------|--|------------|
| The max. radio frequency power in any 100kHz bandwidth outside the frequency band   |            | The max. radio frequency power in any 100 kHz bandwidth within the frequency band. |            |
| FREQUENCY(MHz)  | POWER(dBm) | FREQUENCY(MHz)   | POWER(dBm) |
| 2389.80   | -52.66     | 2484.10  | -42.12     |
| Result  |            |  |            |
| In any 100kHz bandwidth outside the frequency band, the radio frequency power is at least 20dB below that in the 100kHz bandwidth within the band that contains the highest level of the desired power. |            |  |            |



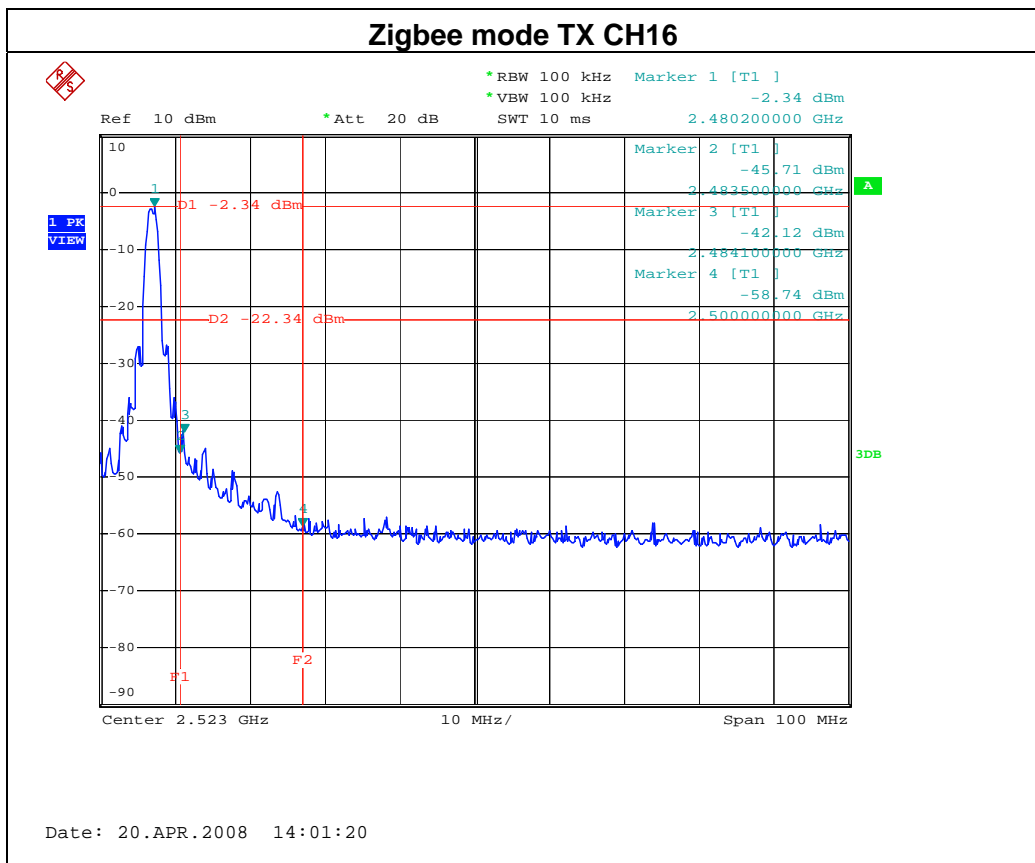
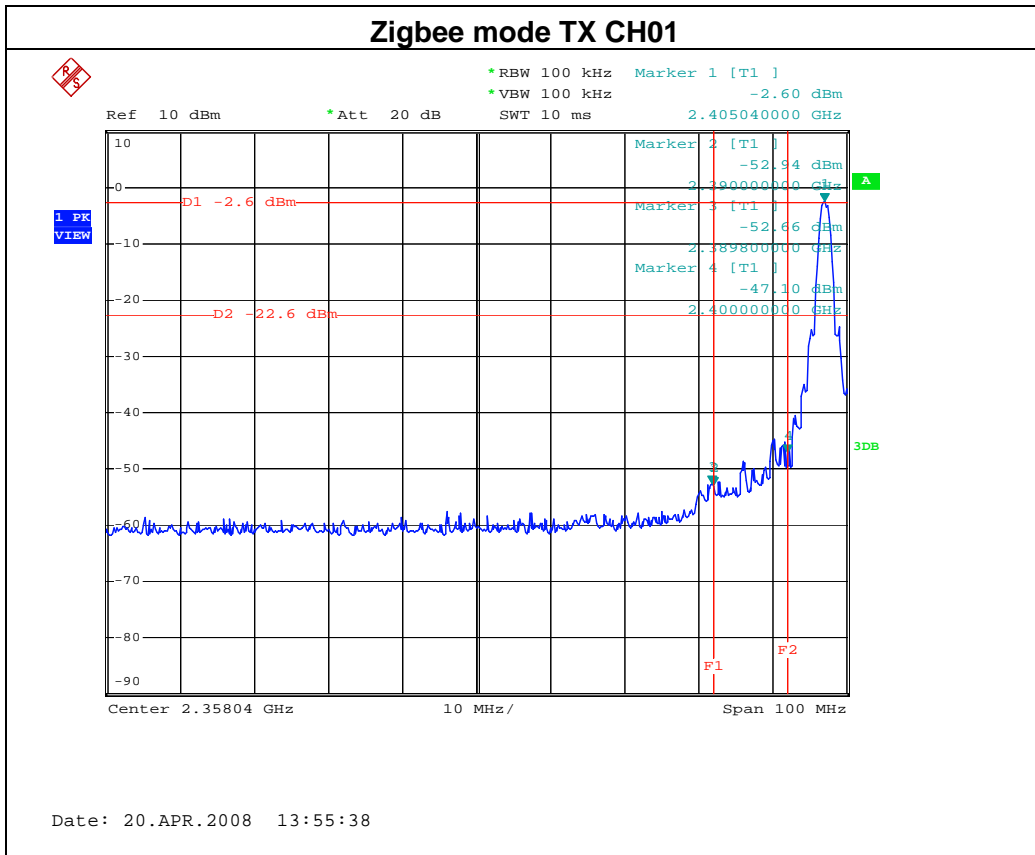

**8. POWER SPECTRAL DENSITY TEST**

**8.1 Applied procedures / limit**

| FCC Part15 (15.247) , Subpart C |                        |                     |                       |        |
|---------------------------------|------------------------|---------------------|-----------------------|--------|
| Section                         | Test Item              | Limit               | Frequency Range (MHz) | Result |
| 15.247 (d)                      | Power Spectral Density | 8 dBm (in any 3KHz) | 2400-2483.5           | PASS   |

**8.1.1 MEASUREMENT INSTRUMENTS LIST**

| Item | Kind of Equipment | Manufacturer | Type No. | Serial No. | Calibrated until |
|------|-------------------|--------------|----------|------------|------------------|
| 1    | Spectrum Analyzer | R&S          | FSP_40   | 100129     | Aug. 16, 2008    |

Remark: " N/A" denotes No Model Name. , Serial No. or No Calibration specified.

**8.1.2 TEST PROCEDURE**

- a. The EUT was directly connected to the spectrum analyzer and antenna output port as show in the block diagram below,
- b. Spectrum Setting : RBW=3KHz, VBW=30 KHz, Sweep time = 500s.

**8.1.3 DEVIATION FROM STANDARD**

No deviation.

**8.1.4 TEST SETUP**

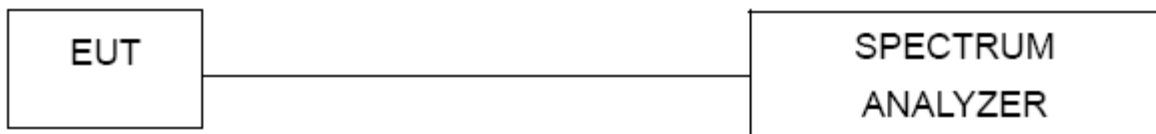

**8.1.5 EUT OPERATION CONDITIONS**

The EUT tested system was configured as the statements of 4.1.6 Unless otherwise a special operating condition is specified in the follows during the testing.

8.1.6 TEST RESULTS

|               |                                   |                     |              |
|---------------|-----------------------------------|---------------------|--------------|
| EUT :         | IEEE 802.15.4 transceivers module | Model Name. :       | ZM100        |
| Temperature : | 24 °C                             | Relative Humidity : | 65%          |
| Pressure :    | 1016 hPa                          | Test Voltage :      | AC 120V/60Hz |
| Test Mode :   | Zigbee mode /CH01, CH08, CH16     |                     |              |

| Test Channel | Frequency (MHz) | Power Density (dBm) | LIMIT (dBm) |
|--------------|-----------------|---------------------|-------------|
| CH01         | 2405            | -13.78              | 8           |
| CH08         | 2440            | -12.66              | 8           |
| CH16         | 2480            | -13.10              | 8           |

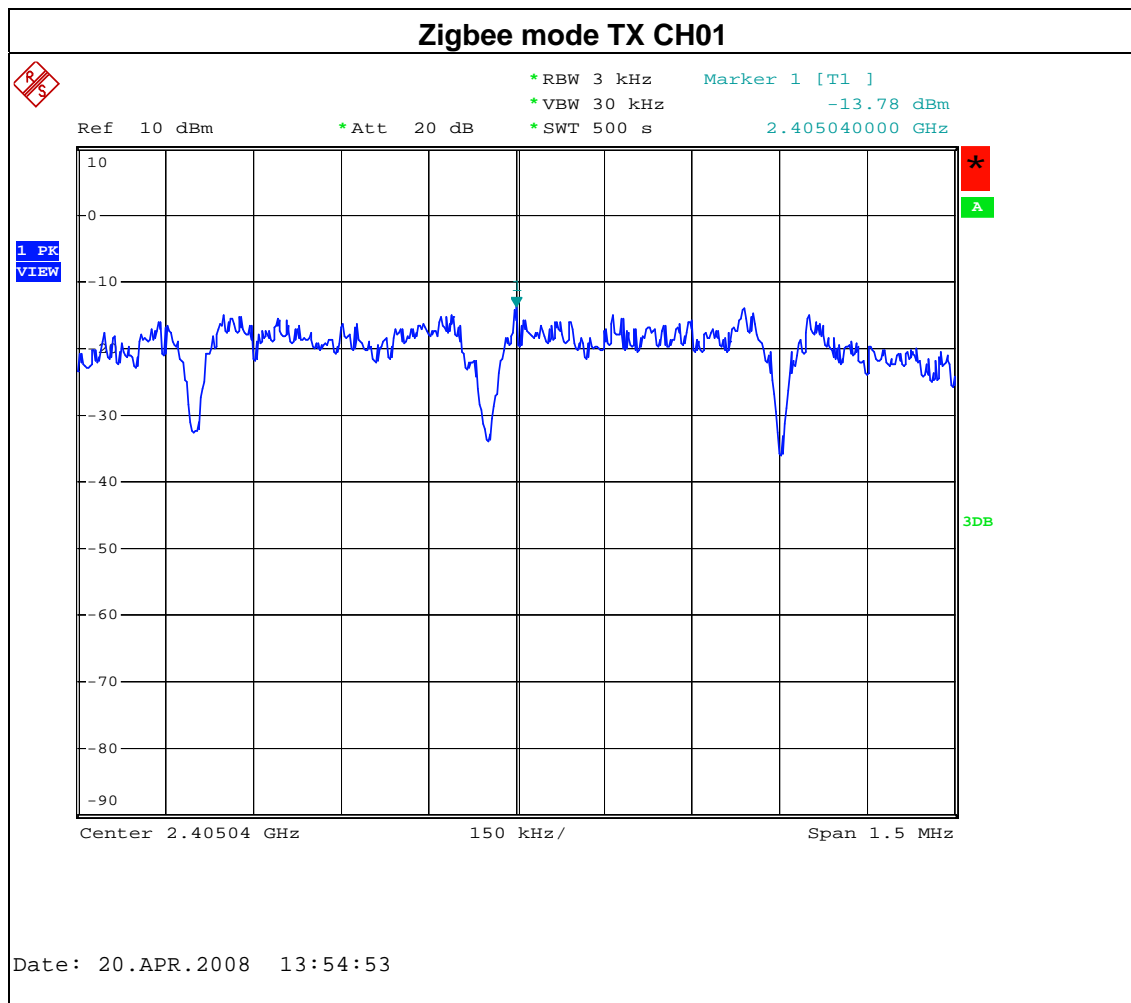

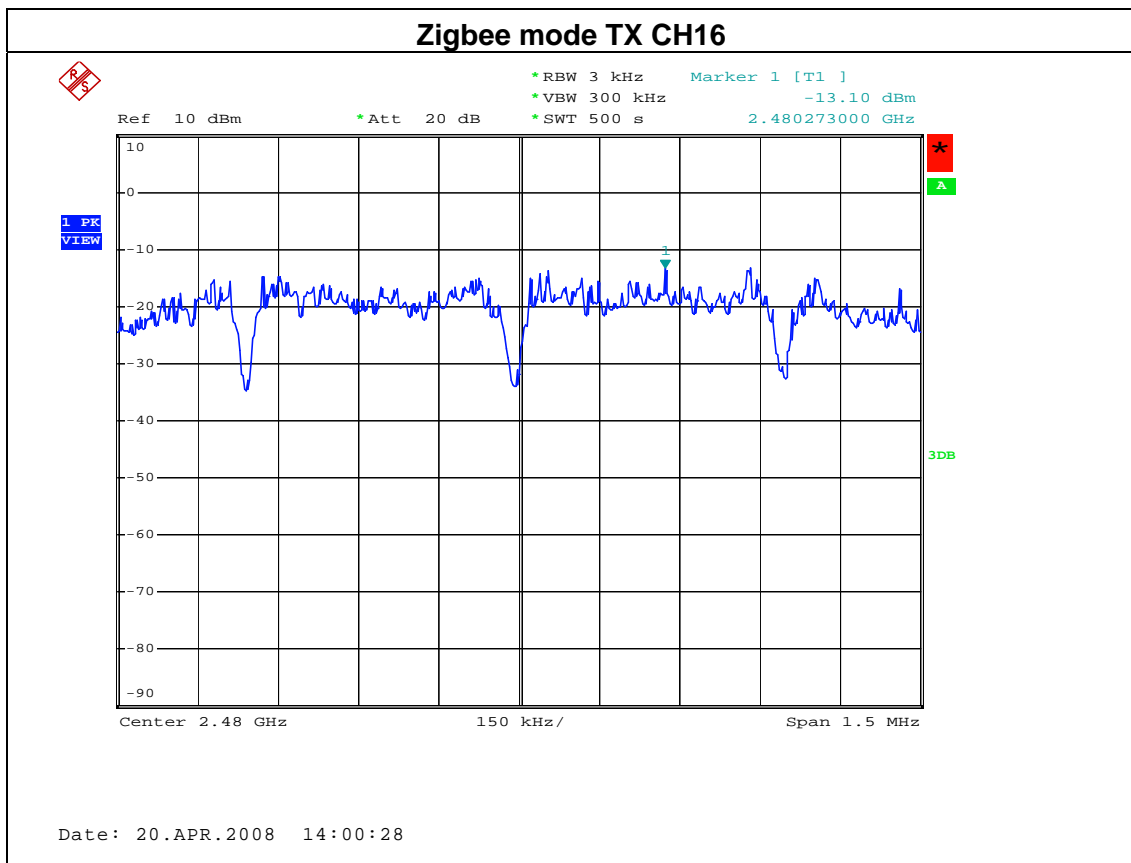
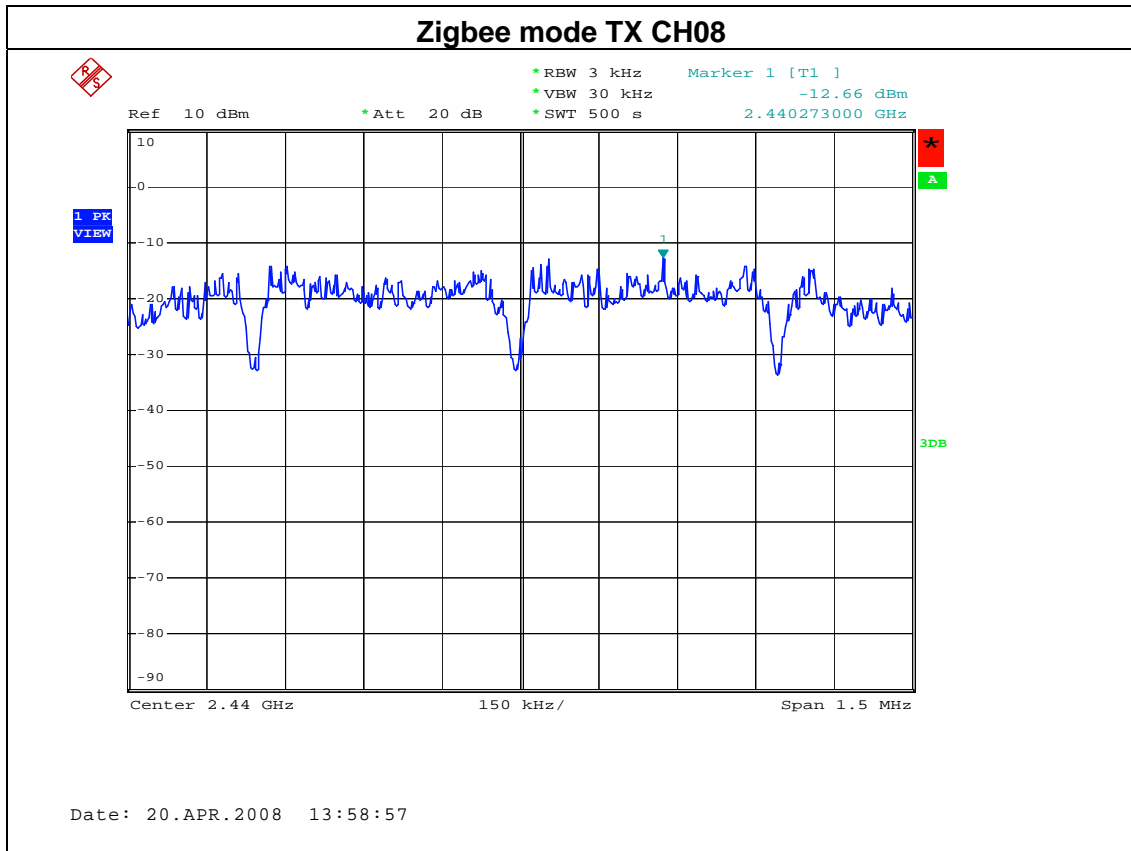

## 9. RF EXPOSURE TEST

### 9.1 APPLIED PROCEDURES / LIMIT

Systems operating under the provisions of this section shall be operated in a manner that ensures that the public is not exposed to radio frequency energy levels in excess limit for maximum permissible exposure. In accordance with 47 CFR FCC Part 2 Subpart J, section 2.1091 this device has been defined as a mobile device whereby a distance of 0.2 m normally can be maintained between the user and the device.

(A) Limits for Occupational / Controlled Exposure

| Frequency Range (MHz) | Electric Field Strength (E) (V/m) | Magnetic Field Strength (H) (A/m) | Power Density (S) (mW/ cm <sup>2</sup> ) | Averaging Time  E  <sup>2</sup> ,  H  <sup>2</sup> or S (minutes) |
|-----------------------|-----------------------------------|-----------------------------------|--|---|
| 0.3-3.0               | 614                               | 1.63                              | (100)*                                   | 6   |
| 3.0-30                | 1842 / f                          | 4.89 / f                          | (900 / f)*                               | 6   |
| 30-300                | 61.4                              | 0.163                             | 1.0                                      | 6   |
| 300-1500              |                                   |                                   | F/300                                    | 6   |
| 1500-100,000          |                                   |                                   | 5  | 6   |

(B) Limits for General Population / Uncontrolled Exposure

| Frequency Range (MHz) | Electric Field Strength (E) (V/m) | Magnetic Field Strength (H) (A/m) | Power Density (S) (mW/ cm <sup>2</sup> ) | Averaging Time  E  <sup>2</sup> ,  H  <sup>2</sup> or S (minutes) |
|-----------------------|-----------------------------------|-----------------------------------|--|---|
| 0.3-1.34              | 614                               | 1.63                              | (100)*                                   | 30  |
| 1.34-30               | 824/f                             | 2.19/f                            | (180/f)*                                 | 30  |
| 30-300                | 27.5                              | 0.073                             | 0.2                                      | 30  |
| 300-1500              |                                   |                                   | F/1500                                   | 30  |
| 1500-100,000          |                                   |                                   | 1.0                                      | 30  |

Note: f = frequency in MHz ; \*Plane-wave equivalent power density

### 9.1.1 MEASUREMENT INSTRUMENTS LIST

| Item | Kind of Equipment | Manufacturer | Type No. | Serial No. | Calibrated until |
|------|-------------------|--------------|----------|------------|------------------|
| 1    | Spectrum Analyzer | R&S          | FSP_40   | 100129     | Aug,16, 2008     |

Remark: " N/A" denotes No Model Name , Serial No. or No Calibration specified.

### 9.1.2 MPE CALCULATION METHOD

$$E \text{ (V/m)} = \frac{\sqrt{30 \times P \times G}}{d} \qquad \text{Power Density: } Pd \text{ (W/m}^2\text{)} = \frac{E^2}{377}$$

**E** = Electric field (V/m)

**P** = Peak RF output power (W)

**G** = EUT Antenna numeric gain (numeric)

**d** = Separation distance between radiator and human body (m)

The formula can be changed to

$$Pd = \frac{30 \times P \times G}{377 \times d^2}$$

From the peak EUT RF output power, the minimum mobile separation distance, d=0.2m, as well as the gain of the used antenna, the RF power density can be obtained

### 9.1.3 DEVIATION FROM STANDARD

No deviation.

### 9.1.4 TEST SETUP

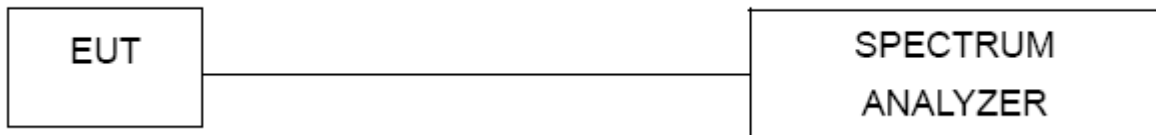

### 9.1.5 EUT OPERATION CONDITIONS

The EUT tested system was configured as the statements of 4.1.6 Unless otherwise a special operating condition is specified in the follows during the testing.

**9.1.6 TEST RESULTS**

|               |                                     |                     |              |
|---------------|-------------------------------------|---------------------|--------------|
| EUT :         | IEEE 802.15.4 transceivers module   | Model Name. :       | ZM100        |
| Temperature : | 24 °C                               | Relative Humidity : | 65%          |
| Pressure :    | 1016 hPa                            | Test Voltage :      | AC 120V/60Hz |
| Test Mode :   | <b>Zigbee mode CH01, CH08, CH16</b> |                     |              |

| Antenna Gain (dBi) | Antenna Gain (numeric) | Peak Output Power (dBm) | Peak Output Power (mW) | Power Density (S) (mW/cm <sup>2</sup> ) | Limit of Power Density (S) (mW/cm <sup>2</sup> ) | Test Result     |
|--------------------|------------------------|-------------------------|------------------------|---|--|-----------------|
| <b>2.50</b>        | <b>1.7783</b>          | <b>1.32</b>             | <b>1.3552</b>          | <b>0.000480</b>                         | <b>1</b>   | <b>Complies</b> |
| 2.50               | 1.7783                 | 1.24                    | 1.3305                 | 0.000471                                | 1  | Complies        |
| 2.50               | 1.7783                 | 1.06                    | 1.2764                 | 0.000452                                | 1  | Complies        |

**10. EUT TEST PHOTO**

**Conducted Measurement Photos**





**Radiated Measurement Photos**



**Radiated Measurement Photos**

