



FCC TEST REPORT (15.407)

REPORT NO.: RF970604L11

MODEL NO.: HM500

RECEIVED: Jun. 04, 2008

TESTED: Jun. 05 ~ Jun. 12, 2008

ISSUED: Jun. 16, 2008

APPLICANT: Quanta Microsystems, Inc.

ADDRESS: 188 Wenhwa 2nd Rd., Kueishan Hsiang
Taoyuan Shien 333, Taiwan, R.O.C.

ISSUED BY: Advance Data Technology Corporation

LAB ADDRESS: No.47, 14th Ling, Chia Pau Tsuen, Linko Hsiang
244, Taipei Hsien, Taiwan, R.O.C.

TEST LOCATION: No. 19, Hwa Ya 2nd Rd, Wen Hwa Tsuen, Kwei
Shan Hsiang, Taoyuan Hsien 333, Taiwan,
R.O.C.

This test report consists of 71 pages in total. It may be duplicated completely for legal use with the approval of the applicant. It should not be reproduced except in full, without the written approval of our laboratory. The client should not use it to claim product endorsement by TAF, A2LA or any government agencies. The test results in the report only apply to the tested sample.





TABLE OF CONTENTS

1.	CERTIFICATION.....	4
2.	SUMMARY OF TEST RESULTS	5
2.1	MEASUREMENT UNCERTAINTY.....	5
3.	GENERAL INFORMATION.....	6
3.1	GENERAL DESCRIPTION OF EUT	6
3.2	DESCRIPTION OF TEST MODES	7
3.2.1	CONFIGURATION OF SYSTEM UNDER TEST	7
3.2.2	TEST MODE APPLICABILITY AND TESTED CHANNEL DETAIL	8
3.3	GENERAL DESCRIPTION OF APPLIED STANDARDS	10
3.4	DESCRIPTION OF SUPPORT UNITS	10
4.	TEST TYPES AND RESULTS	11
4.1	RADIATED EMISSION MEASUREMENT	11
4.1.1	LIMITS OF RADIATED EMISSION MEASUREMENT	11
4.1.2	LIMITS OF UNWANTED EMISSION OUT OF THE RESTRICTED BANDS	12
4.1.3	TEST INSTRUMENTS.....	13
4.1.4	TEST PROCEDURES	14
4.1.5	DEVIATION FROM TEST STANDARD.....	14
4.1.6	TEST SETUP.....	15
4.1.7	EUT OPERATING CONDITION.....	15
4.1.8	TEST RESULTS	16
4.2	CONDUCTED EMISSION MEASUREMENT	20
4.2.1	LIMITS OF CONDUCTED EMISSION MEASUREMENT	20
4.2.2	TEST INSTRUMENTS.....	20
4.2.3	TEST PROCEDURES	21
4.2.4	DEVIATION FROM TEST STANDARD.....	21
4.2.5	TEST SETUP.....	22
4.2.6	EUT OPERATING CONDITIONS	22
4.2.7	TEST RESULTS	23
4.3	PEAK TRANSMIT POWER MEASUREMENT	25
4.3.1	LIMITS OF PEAK TRANSMIT POWER MEASUREMENT	25
4.3.2	TEST INSTRUMENTS.....	25
4.3.3	TEST PROCEDURE.....	25
4.3.4	DEVIATION FROM TEST STANDARD.....	26
4.3.5	TEST SETUP.....	26
4.3.6	EUT OPERATING CONDITIONS	26
4.3.7	TEST RESULTS	27
4.4	PEAK POWER EXCURSION MEASUREMENT	41
4.4.1	LIMITS OF PEAK POWER EXCURSION MEASUREMENT	41
4.4.2	TEST INSTRUMENTS.....	41
4.4.3	TEST PROCEDURE.....	41
4.4.4	DEVIATION FROM TEST STANDARD.....	42
4.4.5	TEST SETUP.....	42
4.4.6	EUT OPERATING CONDITIONS	42
4.4.7	TEST RESULTS	43
4.5	PEAK POWER SPECTRAL DENSITY MEASUREMENT	50
4.5.1	LIMITS OF PEAK POWER SPECTRAL DENSITY MEASUREMENT	50
4.5.2	TEST INSTRUMENTS.....	50
4.5.3	TEST PROCEDURES	50



4.5.4	DEVIATION FROM TEST STANDARD.....	51
4.5.5	TEST SETUP.....	51
4.5.6	EUT OPERATING CONDITIONS.....	51
4.5.7	TEST RESULTS.....	52
4.6	FREQUENCY STABILITY.....	59
4.6.1	LIMITS OF FREQUENCY STABILITY MEASUREMENT.....	59
4.6.2	TEST INSTRUMENTS.....	59
4.6.3	TEST PROCEDURE.....	59
4.6.4	DEVIATION FROM TEST STANDARD.....	60
4.6.5	TEST SETUP.....	60
4.6.6	EUT OPERATING CONDITION.....	60
4.6.7	TEST RESULTS.....	61
4.7	BAND EDGES MEASUREMENT.....	62
4.7.1	TEST INSTRUMENTS.....	62
4.7.2	TEST PROCEDURE.....	63
4.7.3	EUT OPERATING CONDITION.....	63
4.7.4	TEST RESULTS.....	64
4.8	ANTENNA REQUIREMENT.....	68
4.8.1	STANDARD APPLICABLE.....	68
4.8.2	ANTENNA CONNECTED CONSTRUCTION.....	68
5.	PHOTOGRAPHS OF THE TEST CONFIGURATION.....	69
6.	INFORMATION ON THE TESTING LABORATORIES.....	70
7.	APPENDIX A - MODIFICATIONS RECORDERS FOR ENGINEERING CHANGES TO THE EUT BY THE LAB.....	71



1. CERTIFICATION

PRODUCT: WHDI™ Transmitter Module

MODEL: HM500

BRAND: QMI

APPLICANT: Quanta Microsystems, Inc.

TEST SAMPLE: ENGINEERING SAMPLE

TESTED: Jun. 05 ~ Jun. 12, 2008

STANDARDS: FCC Part 15, Subpart E (Section 15.407)

ANSI C63.4-2003

The above equipment (Model: HM500) has been tested by **Advance Data Technology Corporation**, and found compliance with the requirement of the above standards. The test record, data evaluation & Equipment Under Test (EUT) configurations represented herein are true and accurate accounts of the measurements of the sample's EMC characteristics under the conditions specified in this report.

PREPARED BY : Ivy Lin , **DATE:** Jun. 16, 2008
Ivy Lin / Specialist

TECHNICAL ACCEPTANCE : Long Chen , **DATE:** Jun. 16, 2008
Responsible for RF Long Chen / Senior Engineer

APPROVED BY : Gary Chang , **DATE:** Jun. 16, 2008
Gary Chang / Assistant Manager

2. SUMMARY OF TEST RESULTS

The EUT has been tested according to the following specifications:

APPLIED STANDARD: FCC PART 15, SUBPART E (SECTION 15.407)			
STANDARD SECTION	TEST TYPE AND LIMIT	RESULT	REMARK
15.407(b)(5)	AC Power Conducted Emission	PASS	Meet the requirement of limit. Minimum passing margin is -2.87dB at 0.525MHz
15.407(b)(1/2/3) (b)(5)	Electric Field Strength Spurious Emissions, 30MHz ~ 40000MHz	PASS	Meet the requirement of limit. Minimum passing margin is -7.81dB at 5150.00MHz
15.407(a)(1/2/3)	Peak Transmit Power	PASS	Meet the requirement of limit.
15.407(a)(6)	Peak Power Excursion	PASS	Meet the requirement of limit.
15.407(a)(1/2/3)	Peak Power Spectral Density	PASS	Meet the requirement of limit.
15.407(g)	Frequency Stability	PASS	Meet the requirement of limit.

2.1 MEASUREMENT UNCERTAINTY

Where relevant, the following measurement uncertainty levels have been estimated for tests performed on the EUT as specified in CISPR 16-4-2:

MEASUREMENT	FREQUENCY	UNCERTAINTY
Conducted emissions	9kHz~30MHz	2.44 dB
Radiated emissions	30MHz ~ 200MHz	3.19 dB
	200MHz ~1000MHz	3.21 dB
	1GHz ~ 18GHz	2.26 dB
	18GHz ~ 40GHz	1.94 dB

This uncertainty represents an expanded uncertainty expressed at approximately the 95% confidence level using a coverage factor of $k = 2$.

3. GENERAL INFORMATION

3.1 GENERAL DESCRIPTION OF EUT

EUT	WHDI™ Transmitter Module
MODEL NO.	HM500
FCC ID	T5U-HM500
POWER SUPPLY	3.3Vdc from host equipment
MODULATION TYPE	AMIMON Proprietary Modulation
MODULATION TECHNOLOGY	OFDM
TRANSFER RATE	up to 1.5Gbps
FREQUENCY RANGE	5150.0 ~ 5250.0MHz, 5725.0 ~ 5850.0MHz
NUMBER OF CHANNEL	9
OUTPUT POWER	46.648mW for 5150.0 ~ 5250.0MHz 104.060mW for 5725.0 ~ 5850.0MHz
ANTENNA TYPE	Printed antenna with 3.12dBi gain
DATA CABLE	NA
I/O PORTS	NA
ASSOCIATED DEVICES	NA

NOTE:

1. The functions of EUT listed as below:

FREQUENCY Range	TEST STANDARD	REFERENCE REPORT
WLAN 802.11a (5725 ~ 5850MHz)	FCC Part 15, Subpart C (Section 15.247)	RF970604L11-1
WLAN 802.11a (5150 ~ 5250MHz)	FCC Part 15, Subpart E (Section 15.407)	RF970604L11

2. The EUT incorporates a MIMO function. Physically, the EUT provides four completed transmitters and one receiver.

MODULATION MODE	TX FUNCTION
WLAN 802.11a (5725 ~ 5850MHz)	4TX
WLAN 802.11a (5150 ~ 5250MHz)	4TX

3. The above EUT information was declared by manufacturer and for more detailed features description, please refer to the manufacturer's specifications or user's manual.

3.2 DESCRIPTION OF TEST MODES

4 channels are provided for 802.11a:

CHANNEL	FREQUENCY	CHANNEL	FREQUENCY
36	5180MHz	44	5220MHz
40	5200MHz	48	5240MHz

3.2.1 CONFIGURATION OF SYSTEM UNDER TEST

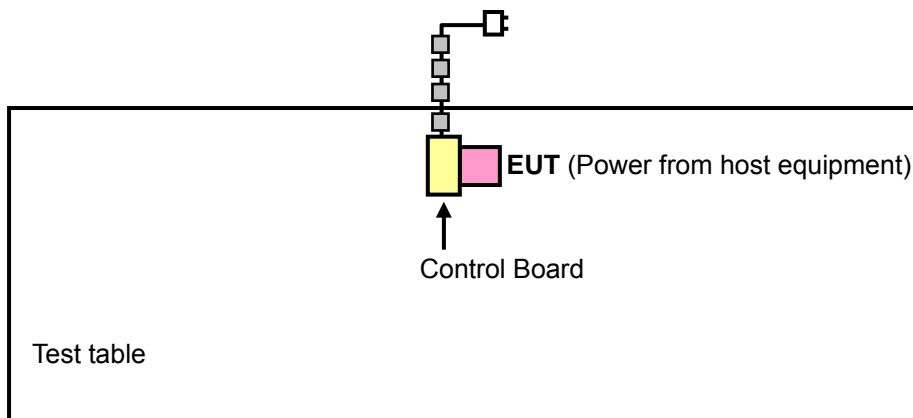

3.2.2 TEST MODE APPLICABILITY AND TESTED CHANNEL DETAIL

EUT CONFIGURE MODE	APPLICABLE TO				DESCRIPTION
	PLC	RE<1G	RE≥1G	APCM	
-	√	√	√	√	-

Where **PLC**: Power Line Conducted Emission **RE<1G**: Radiated Emission below 1GHz
RE≥1G: Radiated Emission above 1GHz **APCM**: Antenna Port Conducted Measurement

RADIATED EMISSION TEST (ABOVE 1GHz):

- Pre-Scan has been conducted to determine the worst-case mode from all possible combinations between available modulations, data rates, antenna XYZ axis and antenna ports (if EUT with antenna diversity architecture).
- Following channel(s) was (were) selected for the final test as listed below.

EUT CONFIGURE MODE	AVAILABLE CHANNEL	TESTED CHANNEL	MODULATION TECHNOLOGY	MODULATION TYPE	DATA RATE (Mbps)	ANTENNA AXIS
-	36 to 48	36, 40, 48	OFDM	AMIMON Proprietary	6.0	X

RADIATED EMISSION TEST (BELOW 1GHz):

- Pre-Scan has been conducted to determine the worst-case mode from all possible combinations between available modulations, data rates and antenna ports (if EUT with antenna diversity architecture).
- Following channel(s) was (were) selected for the final test as listed below.

EUT CONFIGURE MODE	AVAILABLE CHANNEL	TESTED CHANNEL	MODULATION TECHNOLOGY	MODULATION TYPE	DATA RATE (Mbps)	ANTENNA AXIS
-	36 to 48	48	OFDM	AMIMON Proprietary	6.0	X

POWER LINE CONDUCTED EMISSION TEST:

- Pre-Scan has been conducted to determine the worst-case mode from all possible combinations between available modulations, data rates and antenna ports (if EUT with antenna diversity architecture).
- Following channel(s) was (were) selected for the final test as listed below.

EUT CONFIGURE MODE	AVAILABLE CHANNEL	TESTED CHANNEL	MODULATION TECHNOLOGY	MODULATION TYPE	DATA RATE (Mbps)
-	36 to 48	48	OFDM	AMIMON Proprietary	6.0



BANDEDGE MEASUREMENT:

- Pre-Scan has been conducted to determine the worst-case mode from all possible combinations between available modulations, data rates and antenna ports (if EUT with antenna diversity architecture).
- Following channel(s) was (were) selected for the final test as listed below.

EUT CONFIGURE MODE	AVAILABLE CHANNEL	TESTED CHANNEL	MODULATION TECHNOLOGY	MODULATION TYPE	DATA RATE (Mbps)	ANTENNA AXIS
-	36 to 48	36, 48	OFDM	AMIMON Proprietary	6.0	X

ANTENNA PORT CONDUCTED MEASUREMENT:

- Pre-Scan has been conducted to determine the worst-case mode from all possible combinations between available modulations, data rates and antenna ports (if EUT with antenna diversity architecture).
- Following channel(s) was (were) selected for the final test as listed below.

EUT CONFIGURE MODE	AVAILABLE CHANNEL	TESTED CHANNEL	MODULATION TECHNOLOGY	MODULATION TYPE	DATA RATE (Mbps)
-	36 to 48	36, 40, 48	OFDM	AMIMON Proprietary	6.0



3.3 GENERAL DESCRIPTION OF APPLIED STANDARDS

The EUT is a RF Product. According to the specifications of the manufacturer, it must comply with the requirements of the following standards:

FCC Part 15, Subpart E (15.407)

ANSI C63.4-2003

All test items have been performed and recorded as per the above standards.

NOTE: The EUT is also considered as a kind of computer peripheral, because the connection to computer is necessary for typical use. It has been verified to comply with the requirements of FCC Part 15, Subpart B, Class B (DoC). The test report has been issued separately.

3.4 DESCRIPTION OF SUPPORT UNITS

The EUT has been tested as an independent unit together with other necessary accessories or support units. The following support units or accessories were used to form a representative test configuration during the tests.

NO.	PRODUCT	BRAND	MODEL NO.	SERIAL NO.	FCC ID
1	Control Board	NA	NA	NA	NA
2	Adapter	DVE	JPW160 KA0502F02	NA	NA

NO.	SIGNAL CABLE DESCRIPTION OF THE ABOVE SUPPORT UNITS
1	NA
2	NA

NOTE: 1. All power cords of the above support units are non shielded (1.8m).
2. Item 1-2 were provided by client.

4. TEST TYPES AND RESULTS

4.1 RADIATED EMISSION MEASUREMENT

4.1.1 LIMITS OF RADIATED EMISSION MEASUREMENT

Emissions radiated outside of the specified bands, shall be according to the general radiated limits in 15.209 as following:

FREQUENCIES (MHz)	FIELD STRENGTH (microvolts/meter)	MEASUREMENT DISTANCE (meters)
0.009 ~ 0.490	2400/F(kHz)	300
0.490 ~ 1.705	24000/F(kHz)	30
1.705 ~ 30.0	30	30
30 ~ 88	100	3
88 ~ 216	150	3
216 ~ 960	200	3
Above 960	500	3

NOTE:

1. The lower limit shall apply at the transition frequencies.
2. Emission level (dBuV/m) = 20 log Emission level (uV/m).
3. As shown in 15.35(b), for frequencies above 1000MHz, the field strength limits are based on average detector, however, the peak field strength of any emission shall not exceed the maximum permitted average limits, specified above by more than 20dB under any condition of modulation.

4.1.2 LIMITS OF UNWANTED EMISSION OUT OF THE RESTRICTED BANDS

FREQUENCIES (MHz)	EIRP LIMIT (dBm)		EQUIVALENT FIELD STRENGTH AT 3m (dBμV/m) *NOTE 3	
	PK	AV	PK	AV
5150 ~ 5250	-7	-27	88.3	68.3
5250 ~ 5350	-7	-27	88.3	68.3
5470 ~ 5725	-7	-27	88.3	68.3

NOTE:

1. For frequencies 10MHz or greater above or below the band edge.
2. All emissions within the frequency range from the band edge to 10MHz above or below the band edge.
3. The following formula is used to convert the equipment isotropic radiated power (eirp) to field strength:

$$E = \frac{1000000\sqrt{30P}}{3} \quad \mu\text{V/m, where P is the eirp (Watts).$$



4.1.3 TEST INSTRUMENTS

DESCRIPTION & MANUFACTURER	MODEL NO.	SERIAL NO.	CALIBRATED UNTIL
Test Receiver ROHDE & SCHWARZ	ESCI	100424	Jul. 27, 2008
Spectrum Analyzer Agilent	E4446A	MY44360128	Dec. 06, 2008
BILOG Antenna SCHWARZBECK	VULB9168	9168-160	May 01, 2009
HORN Antenna SCHWARZBECK	9120D	9120D-209	Jun. 28, 2008
HORN Antenna SCHWARZBECK	BBHA 9170	BBHA9170243	Dec. 24, 2008
Preamplifier Agilent	8447D	2944A10633	Oct. 28, 2008
Preamplifier Agilent	8449B	3008A01964	Oct. 23, 2008
RF signal cable HUBER+SUHNNER	SUCOFLEX 104	283402/4	Dec. 06, 2008
RF signal cable HUBER+SUHNNER	SUCOFLEX 104	251644/4	Dec. 06, 2008
Software ADT.	ADT_Radiated_V7.6	NA	NA
Antenna Tower inn-co GmbH	MA 4000	013303	NA
Antenna Tower Controller inn-co GmbH	CO2000	017303	NA
Turn Table ADT.	TT100.	TT93021703	NA
Turn Table Controller ADT.	SC100.	SC93021703	NA

- NOTE:**
1. The calibration interval of the above test instruments is 12 months and the calibrations are traceable to NML/ROC and NIST/USA.
 2. The test was performed in HwaYa Chamber 3.
 3. The horn antenna and HP preamplifier (model: 8449B) are used only for the measurement of emission frequency above 1GHz if tested.
 4. The FCC Site Registration No. is 988962.
 5. The IC Site Registration No. is IC3789B-3.

4.1.4 TEST PROCEDURES

- a. The EUT was placed on the top of a rotating table 0.8 meters above the ground at a 3 meter semi-anechoic chamber. The table was rotated 360 degrees to determine the position of the highest radiation.
- b. The EUT was set 3 meters away from the interference-receiving antenna, which was mounted on the top of a variable-height antenna tower.
- c. The antenna is a broadband antenna, and its height is varied from one meter to four meters above the ground to determine the maximum value of the field strength. Both horizontal and vertical polarizations of the antenna are set to make the measurement.
- d. For each suspected emission, the EUT was arranged to its worst case and then the antenna was tuned to heights from 1 meter to 4 meters and the rotatable table was turned from 0 degrees to 360 degrees to find the maximum reading.
- e. The test-receiver system was set to Peak Detect Function and Specified Bandwidth with Maximum Hold Mode.
- f. If the emission level of the EUT in peak mode was 10dB lower than the limit specified, then testing could be stopped and the peak values of the EUT would be reported. Otherwise the emissions that did not have 10dB margin would be re-tested one by one using peak, quasi-peak or average method as specified and then reported in a data sheet.

NOTE:

1. The resolution bandwidth and video bandwidth of test receiver/spectrum analyzer is 120kHz for Peak detection (PK) and Quasi-peak detection (QP) at frequency below 1GHz.
2. The resolution bandwidth of test receiver/spectrum analyzer is 1MHz and video bandwidth is 3MHz for Peak detection at frequency above 1GHz.
3. The resolution bandwidth of test receiver/spectrum analyzer is 1MHz and the video bandwidth is 10Hz for Average detection (AV) at frequency above 1GHz.
4. All modes of operation were investigated and the worst-case emissions are reported.

4.1.5 DEVIATION FROM TEST STANDARD

No deviation

4.1.6 TEST SETUP

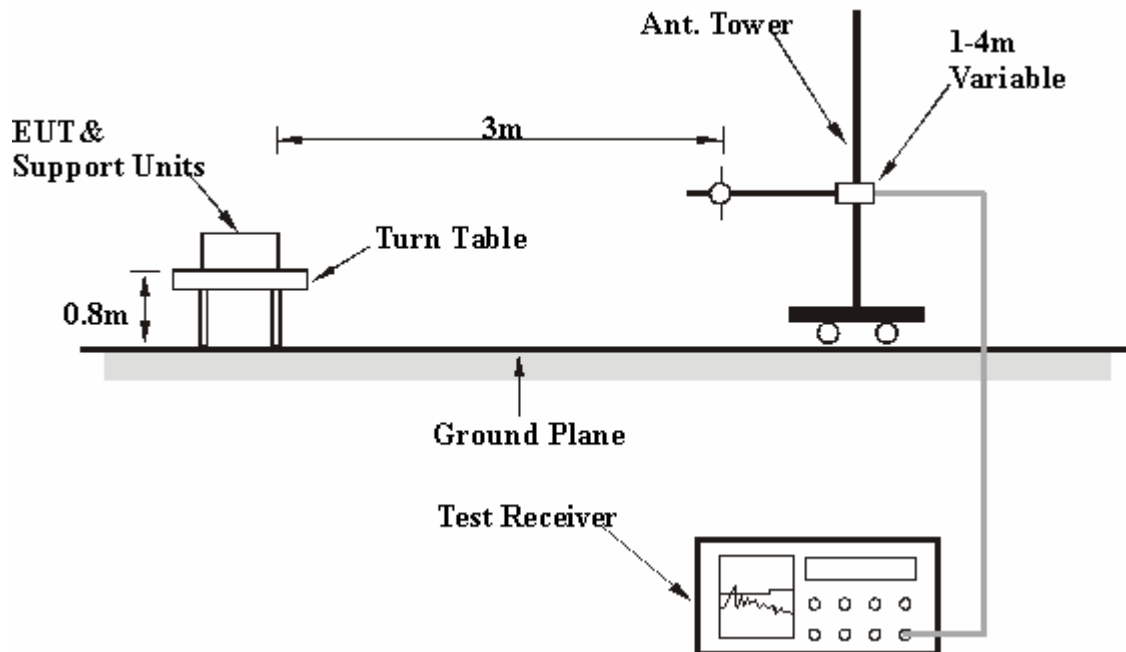

For the actual test configuration, please refer to the attached file (Test Setup Photo).

4.1.7 EUT OPERATING CONDITION

- a. The EUT ran a test program (provided by manufacturer) to enable all functions under transmission condition continuously at specific channel frequency.



4.1.8 TEST RESULTS

802.11a OFDM MODULATION

EUT TEST CONDITION		MEASUREMENT DETAIL	
CHANNEL	Channel 36	FREQUENCY RANGE	1 ~ 40GHz
INPUT POWER (SYSTEM)	120Vac, 60 Hz	DETECTOR FUNCTION	Peak (PK) Average (AV)
ENVIRONMENTAL CONDITIONS	250deg. C, 65%RH 999hPa	TESTED BY	Brad Wu

ANTENNA POLARITY & TEST DISTANCE: HORIZONTAL AT 3 M								
NO.	FREQ. (MHz)	EMISSION LEVEL (dBuV/m)	LIMIT (dBuV/m)	MARGIN (dB)	ANTENNA HEIGHT (m)	TABLE ANGLE (Degree)	RAW VALUE (dBuV)	CORRECTION FACTOR (dB/m)
1	#5150.00	63.59 PK	74.00	-10.41	1.31 H	13	24.70	38.89
2	#5150.00	46.19 AV	54.00	-7.81	1.31 H	13	7.30	38.89
3	*5180.00	112.99 PK			1.31 H	13	74.01	38.98
4	*5180.00	99.63 AV			1.31 H	13	60.65	38.98
5	10360.00	60.86 PK	88.30	-27.44	1.06 H	225	11.32	49.54
6	10360.00	48.11 AV	68.30	-20.19	1.06 H	225	-1.43	49.54
ANTENNA POLARITY & TEST DISTANCE: VERTICAL AT 3 M								
NO.	FREQ. (MHz)	EMISSION LEVEL (dBuV/m)	LIMIT (dBuV/m)	MARGIN (dB)	ANTENNA HEIGHT (m)	TABLE ANGLE (Degree)	RAW VALUE (dBuV)	CORRECTION FACTOR (dB/m)
1	#5150.00	59.43 PK	74.00	-14.57	1.15 V	153	20.54	38.89
2	#5150.00	41.96 AV	54.00	-12.04	1.15 V	153	3.07	38.89
3	*5180.00	108.69 PK			1.15 V	153	69.71	38.98
4	*5180.00	95.41 AV			1.15 V	153	56.43	38.98
5	10360.00	60.84 PK	88.30	-27.46	1.06 V	244	11.30	49.54
6	10360.00	48.02 AV	68.30	-20.28	1.06 V	244	-1.52	49.54

- REMARKS:**
1. Emission level (dBuV/m) = Raw Value (dBuV) + Correction Factor (dB/m).
 2. Correction Factor (dB/m) = Antenna Factor (dB/m) + Cable Factor (dB).
 3. The other emission levels were very low against the limit.
 4. Margin value = Emission level – Limit value.
 5. “ * “: Fundamental frequency.
 6. “ # “: The radiated frequency falling in the restricted band.



EUT TEST CONDITION		MEASUREMENT DETAIL	
CHANNEL	Channel 40	FREQUENCY RANGE	1 ~ 40GHz
INPUT POWER (SYSTEM)	120Vac, 60 Hz	DETECTOR FUNCTION	Peak (PK) Average (AV)
ENVIRONMENTAL CONDITIONS	250deg. C, 65%RH 999hPa	TESTED BY	Brad Wu

ANTENNA POLARITY & TEST DISTANCE: HORIZONTAL AT 3 M								
NO.	FREQ. (MHz)	EMISSION LEVEL (dBuV/m)	LIMIT (dBuV/m)	MARGIN (dB)	ANTENNA HEIGHT (m)	TABLE ANGLE (Degree)	RAW VALUE (dBuV)	CORRECTION FACTOR (dB/m)
1	*5200.00	113.28 PK			1.44 H	309	74.24	39.04
2	*5200.00	99.69 AV			1.44 H	309	60.65	39.04
3	10400.00	61.23 PK	88.30	-27.07	1.13 H	28	11.55	49.68
4	10400.00	48.64 AV	68.30	-19.66	1.13 H	28	-1.04	49.68
ANTENNA POLARITY & TEST DISTANCE: VERTICAL AT 3 M								
NO.	FREQ. (MHz)	EMISSION LEVEL (dBuV/m)	LIMIT (dBuV/m)	MARGIN (dB)	ANTENNA HEIGHT (m)	TABLE ANGLE (Degree)	RAW VALUE (dBuV)	CORRECTION FACTOR (dB/m)
1	*5200.00	108.95 PK			1.14 V	151	69.91	39.04
2	*5200.00	95.66 AV			1.14 V	151	56.62	39.04
3	10400.00	61.15 PK	88.30	-27.15	1.06 V	223	11.47	49.68
4	10400.00	48.35 AV	68.30	-19.95	1.06 V	223	-1.33	49.68

- REMARKS:**
1. Emission level (dBuV/m) = Raw Value (dBuV) + Correction Factor (dB/m).
 2. Correction Factor (dB/m) = Antenna Factor (dB/m) + Cable Factor (dB).
 3. The other emission levels were very low against the limit.
 4. Margin value = Emission level – Limit value.
 5. “ * “: Fundamental frequency.
 6. “ # ”: The radiated frequency falling in the restricted band.



EUT TEST CONDITION		MEASUREMENT DETAIL	
CHANNEL	Channel 48	FREQUENCY RANGE	1 ~ 40GHz
INPUT POWER (SYSTEM)	120Vac, 60 Hz	DETECTOR FUNCTION	Peak (PK) Average (AV)
ENVIRONMENTAL CONDITIONS	250deg. C, 65%RH 999hPa	TESTED BY	Brad Wu

ANTENNA POLARITY & TEST DISTANCE: HORIZONTAL AT 3 M								
NO.	FREQ. (MHz)	EMISSION LEVEL (dBuV/m)	LIMIT (dBuV/m)	MARGIN (dB)	ANTENNA HEIGHT (m)	TABLE ANGLE (Degree)	RAW VALUE (dBuV)	CORRECTION FACTOR (dB/m)
1	*5240.00	115.64 PK			1.65 H	273	76.53	39.11
2	*5240.00	102.04 AV			1.65 H	273	62.93	39.11
3	#5350.00	52.78 PK	74.00	-21.22	1.65 H	273	13.57	39.21
4	#5350.00	40.64 AV	54.00	-13.36	1.65 H	273	1.43	39.21
5	6288.00	61.14 PK	88.30	-27.16	1.00 H	348	20.00	41.14
6	6288.00	45.46 AV	68.30	-22.84	1.00 H	348	4.32	41.14
7	10480.00	60.46 PK	88.30	-27.84	1.02 H	246	10.64	49.82
8	10480.00	47.60 AV	68.30	-20.70	1.02 H	246	-2.22	49.82

ANTENNA POLARITY & TEST DISTANCE: VERTICAL AT 3 M								
NO.	FREQ. (MHz)	EMISSION LEVEL (dBuV/m)	LIMIT (dBuV/m)	MARGIN (dB)	ANTENNA HEIGHT (m)	TABLE ANGLE (Degree)	RAW VALUE (dBuV)	CORRECTION FACTOR (dB/m)
1	#4192.00	49.28 PK	74.00	-24.72	1.12 V	305	12.78	36.51
2	#4192.00	42.66 AV	54.00	-11.34	1.12 V	305	6.16	36.51
3	*5240.00	110.81 PK			1.14 V	150	71.70	39.11
4	*5240.00	97.53 AV			1.14 V	150	58.42	39.11
5	#5350.00	49.68 PK	74.00	-24.32	1.14 V	150	10.47	39.21
6	#5350.00	37.52 AV	54.00	-16.48	1.14 V	150	-1.69	39.21
7	10480.00	60.95 PK	88.30	-27.35	1.04 V	231	11.13	49.82
8	10480.00	48.13 AV	68.30	-20.17	1.04 V	231	-1.69	49.82

- REMARKS:**
1. Emission level (dBuV/m) = Raw Value (dBuV) + Correction Factor (dB/m).
 2. Correction Factor (dB/m) = Antenna Factor (dB/m) + Cable Factor (dB).
 3. The other emission levels were very low against the limit.
 4. Margin value = Emission level – Limit value.
 5. “ * ”: Fundamental frequency.
 6. “ # ”: The radiated frequency falling in the restricted band.



BELOW 1GHz WORST-CASE DATA : 802.11a OFDM MODULATION

EUT TEST CONDITION		MEASUREMENT DETAIL	
CHANNEL	Channel 48	FREQUENCY RANGE	Below 1000MHz
INPUT POWER (SYSTEM)	120Vac, 60 Hz	DETECTOR FUNCTION	Quasi-Peak
ENVIRONMENTAL CONDITIONS	25deg. C, 65%RH 993hPa	TESTED BY	Brad Wu

ANTENNA POLARITY & TEST DISTANCE: HORIZONTAL AT 3 M								
NO.	FREQ. (MHz)	EMISSION LEVEL (dBuV/m)	LIMIT (dBuV/m)	MARGIN (dB)	ANTENNA HEIGHT (m)	TABLE ANGLE (Degree)	RAW VALUE (dBuV)	CORRECTION FACTOR (dB/m)
1	278.77	19.24 QP	46.00	-26.76	1.00 H	274	4.60	14.64
2	319.60	26.76 QP	46.00	-19.24	1.00 H	82	11.10	15.66
3	560.69	25.65 QP	46.00	-20.35	1.50 H	148	4.14	21.51
4	720.12	25.05 QP	46.00	-20.95	1.00 H	313	0.27	24.78
5	799.84	27.25 QP	46.00	-18.75	1.00 H	268	1.37	25.88
6	881.50	28.73 QP	46.00	-17.27	1.00 H	217	1.37	27.36

ANTENNA POLARITY & TEST DISTANCE: VERTICAL AT 3 M								
NO.	FREQ. (MHz)	EMISSION LEVEL (dBuV/m)	LIMIT (dBuV/m)	MARGIN (dB)	ANTENNA HEIGHT (m)	TABLE ANGLE (Degree)	RAW VALUE (dBuV)	CORRECTION FACTOR (dB/m)
1	88.23	18.36 QP	43.50	-25.14	1.00 V	298	9.15	9.21
2	286.55	17.07 QP	46.00	-28.93	1.50 V	151	2.25	14.83
3	502.36	19.06 QP	46.00	-26.94	1.50 V	10	-1.27	20.33
4	603.47	21.79 QP	46.00	-24.21	1.00 V	49	-0.75	22.54
5	745.40	24.91 QP	46.00	-21.09	1.00 V	133	-0.61	25.52
6	864.00	26.65 QP	46.00	-19.35	1.00 V	67	-0.49	27.14

- REMARKS:**
1. Emission level (dBuV/m) = Raw Value (dBuV) + Correction Factor (dB/m).
 2. Correction Factor (dB/m) = Antenna Factor (dB/m) + Cable Factor (dB).
 3. The other emission levels were very low against the limit.
 4. Margin value = Emission level – Limit value.

4.2 CONDUCTED EMISSION MEASUREMENT

4.2.1 LIMITS OF CONDUCTED EMISSION MEASUREMENT

FREQUENCY OF EMISSION (MHz)	CONDUCTED LIMIT (dB μ V)	
	Quasi-peak	Average
0.15 ~ 0.5	66 to 56	56 to 46
0.5 ~ 5	56	46
5 ~ 30	60	50

- NOTE:**
1. The lower limit shall apply at the transition frequencies.
 2. The limit decreases in line with the logarithm of the frequency in the range of 0.15 to 0.50MHz.
 3. All emanations from a class A/B digital device or system, including any network of conductors and apparatus connected thereto, shall not exceed the level of field strengths specified above.

4.2.2 TEST INSTRUMENTS

DESCRIPTION & MANUFACTURER	MODEL NO.	SERIAL NO.	CALIBRATED UNTIL
Test Receiver ROHDE & SCHWARZ	ESCS30	100289	Dec. 06, 2008
RF signal cable Woken	5D-FB	Cable-HYC01-01	Jan. 06, 2009
LISN ROHDE & SCHWARZ	ESH3-Z5	100312	Jan. 30, 2009
LISN ROHDE & SCHWARZ	ESH2-Z5	100104	Sep. 11, 2008
Software ADT	ADT_Cond_V3	NA	NA

- NOTE:**
1. The calibration interval of the above test instruments is 12 months and the calibrations are traceable to NML/ROC and NIST/USA.
 2. The test was performed in HwaYa Shielded Room 1.
 3. The VCCI Site Registration No. is C-2040.

4.2.3 TEST PROCEDURES

- a. The EUT was placed 0.4 meters from the conducting wall of the shielded room with EUT being connected to the power mains through a line impedance stabilization network (LISN). Other support units were connected to the power mains through another LISN. The two LISNs provide 50 ohm/ 50uH of coupling impedance for the measuring instrument.
- b. Both lines of the power mains connected to the EUT were checked for maximum conducted interference.
- c. The frequency range from 150kHz to 30MHz was searched. Emission levels under (Limit - 20dB) was not recorded.

4.2.4 DEVIATION FROM TEST STANDARD

No deviation

4.2.5 TEST SETUP

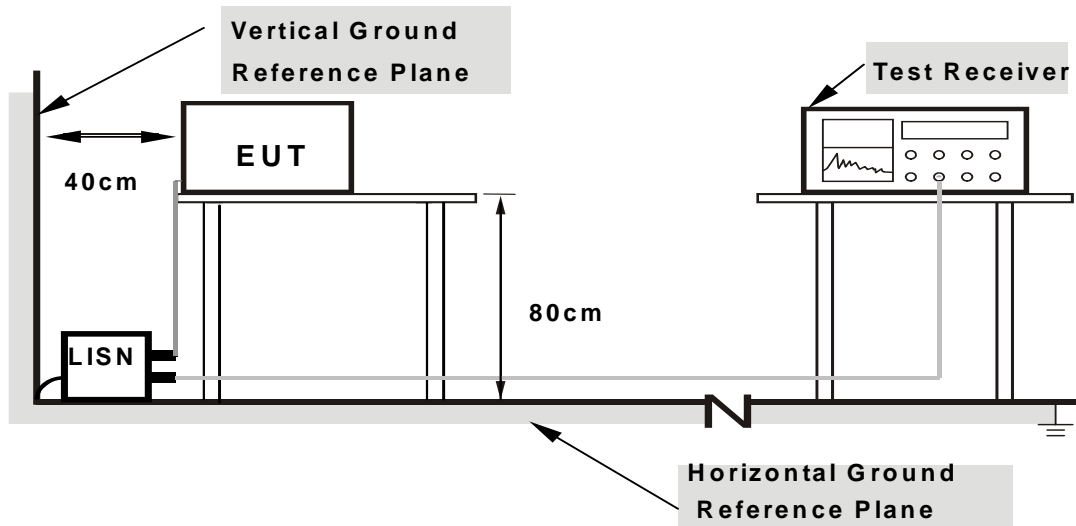

- Note:**
1. Support units were connected to second LISN.
 2. Both of LISNs (AMN) are 80 cm from EUT and at least 80 from other units and other metal planes

For the actual test configuration, please refer to the attached file (Test Setup Photo).

4.2.6 EUT OPERATING CONDITIONS

Same as 4.1.6.

4.2.7 TEST RESULTS

WORST-CASE DATA : 802.11a OFDM MODULATION

EUT TEST CONDITION		MEASUREMENT DETAIL	
CHANNEL	Channel 48	PHASE	Line 1
MODULATION TYPE	AMIMON Proprietary	INPUT POWER (SYSTEM)	120Vac, 60Hz
TRANSFER RATE	6.0Mbps	6dB BANDWIDTH	9kHz
ENVIRONMENTAL CONDITIONS	20deg. C, 60%RH, 982hPa	TESTED BY	Match Tsui

No	Freq. [MHz]	Corr. Factor (dB)	Reading Value [dB (uV)]		Emission Level [dB (uV)]		Limit [dB (uV)]		Margin (dB)	
			Q.P.	AV.	Q.P.	AV.	Q.P.	AV.	Q.P.	AV.
1	0.197	0.20	48.33	-	48.53	-	63.74	53.74	-15.21	-
2	0.262	0.20	44.35	-	44.55	-	61.37	51.37	-16.82	-
3	0.459	0.20	39.17	-	39.37	-	56.72	46.72	-17.35	-
4	0.525	0.20	47.42	42.93	47.62	43.13	56.00	46.00	-8.38	-2.87
5	0.982	0.20	38.47	-	38.67	-	56.00	46.00	-17.33	-
6	1.637	0.20	34.56	-	34.76	-	56.00	46.00	-21.24	-

- REMARKS:**
1. Q.P. and AV. are abbreviations of quasi-peak and average individually.
 2. "-": The Quasi-peak reading value also meets average limit and measurement with the average detector is unnecessary.
 3. The emission levels of other frequencies were very low against the limit.
 4. Margin value = Emission level - Limit value
 5. Correction factor = Insertion loss + Cable loss
 6. Emission Level = Correction Factor + Reading Value.

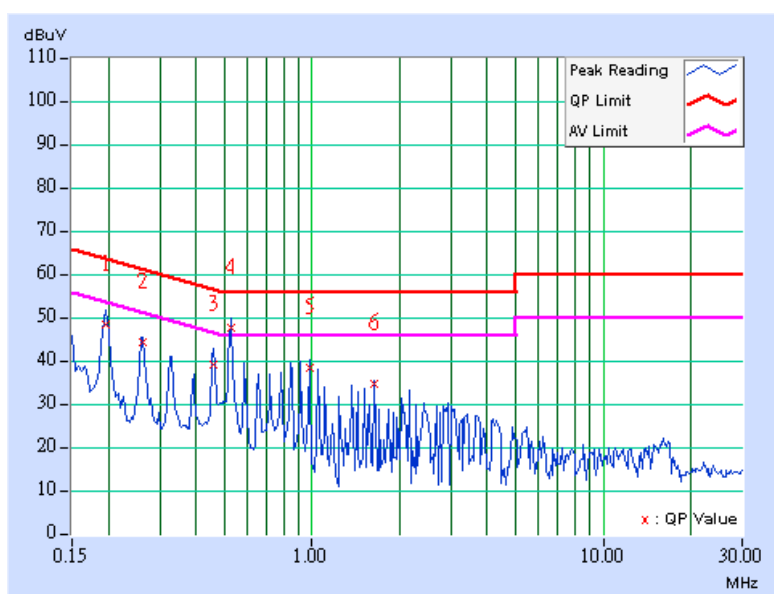

EUT TEST CONDITION		MEASUREMENT DETAIL	
CHANNEL	Channel 48	PHASE	Line 2
MODULATION TYPE	AMIMON Proprietary	INPUT POWER (SYSTEM)	120Vac, 60Hz
TRANSFER RATE	6.0Mbps	6dB BANDWIDTH	9kHz
ENVIRONMENTAL CONDITIONS	20deg. C, 60%RH, 982hPa	TESTED BY	Match Tsui

No	Freq. [MHz]	Corr. Factor (dB)	Reading Value [dB (uV)]		Emission Level [dB (uV)]		Limit [dB (uV)]		Margin (dB)	
			Q.P.	AV.	Q.P.	AV.	Q.P.	AV.	Q.P.	AV.
1	0.197	0.20	43.87	-	44.07	-	63.74	53.74	-19.67	-
2	0.392	0.20	35.49	-	35.69	-	58.02	48.02	-22.33	-
3	0.459	0.20	40.61	-	40.81	-	56.72	46.72	-15.91	-
4	0.525	0.20	46.54	41.89	46.74	42.09	56.00	46.00	-9.26	-3.91
5	0.982	0.20	37.49	-	37.69	-	56.00	46.00	-18.31	-
6	1.504	0.20	34.57	-	34.77	-	56.00	46.00	-21.23	-

- REMARKS:**
1. Q.P. and AV. are abbreviations of quasi-peak and average individually.
 2. "-": The Quasi-peak reading value also meets average limit and measurement with the average detector is unnecessary.
 3. The emission levels of other frequencies were very low against the limit.
 4. Margin value = Emission level - Limit value
 5. Correction factor = Insertion loss + Cable loss
 6. Emission Level = Correction Factor + Reading Value.

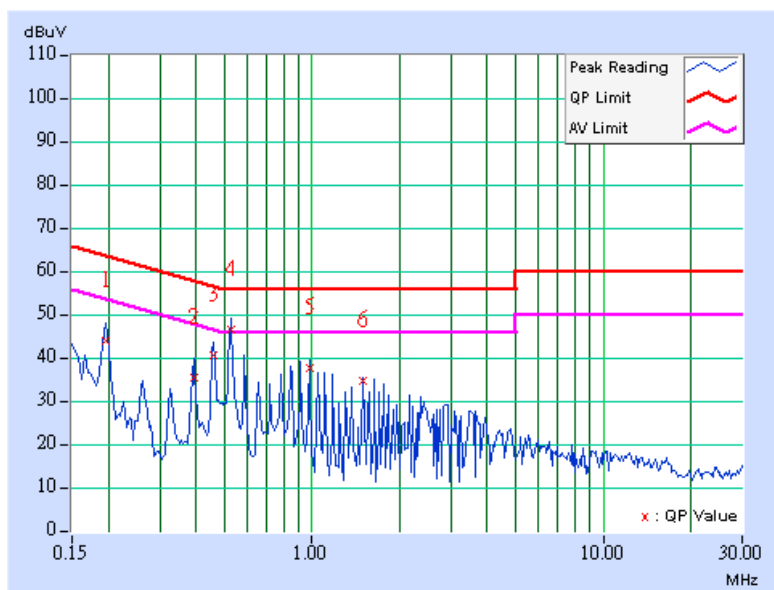



4.3 PEAK TRANSMIT POWER MEASUREMENT

4.3.1 LIMITS OF PEAK TRANSMIT POWER MEASUREMENT

FREQUENCY BAND	LIMIT
5.15 ~ 5.25GHz	The lesser of 50mW (17dBm) or 4dBm + 10logB

NOTE: Where B is the 26dB emission bandwidth in MHz.

4.3.2 TEST INSTRUMENTS

DESCRIPTION & MANUFACTURER	MODEL NO.	SERIAL NO.	CALIBRATED UNTIL
R&S SPECTRUM ANALYZER	FSP40	100040	Jun. 28, 2008

NOTE: The calibration interval of the above test instruments is 12 months and the calibrations are traceable to NML/ROC and NIST/USA.

4.3.3 TEST PROCEDURE

- a. The transmitter output was connected to the spectrum analyzer.
- b. Set span to encompass the entire emission bandwidth of the signal.
- c. Set RBW to 1MHz, VBW to 3MHz.
- d. Using the spectrum analyzer's channel power measurement function to measure the output power.

NOTE: The test is performed in accordance with FCC Public Notice: APPENDIX A Guidelines for Assessing Unlicensed National Information Infrastructure (U-NII) Devices – Part 15, Subpart E, August 2002.

The transmitter output operates continuously therefore Method # 1 is used.

4.3.4 DEVIATION FROM TEST STANDARD

No deviation

4.3.5 TEST SETUP

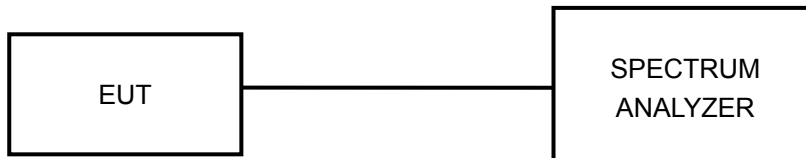

4.3.6 EUT OPERATING CONDITIONS

The software provided by client to enable the EUT under transmission condition continuously at specific channel frequencies individually.



4.3.7 TEST RESULTS

PEAK POWER OUTPUT: 802.11a OFDM MODULATION

MODULATION TYPE	AMIMON Proprietary	TRANSFER RATE	6.0Mbps
INPUT POWER (SYSTEM)	120Vac, 60Hz	ENVIRONMENTAL CONDITIONS	27 deg.C, 66 %RH, 991hPa
TESTED BY	Dean Wang		

CHANNEL	CHANNEL FREQUENCY (MHz)	PEAK POWER OUTPUT (dBm)			
		CHAIN 0	CHAIN 1	CHAIN 2	CHAIN 3
36	5180	11.13	9.12	10.04	8.55
40	5200	11.57	9.60	10.63	9.03
48	5240	11.62	10.07	11.15	9.51

CHANNEL	CHANNEL FREQUENCY (MHz)	TOTAL PEAK POWER (mW)	TOTAL PEAK POWER (dBm)	PEAK POWER LIMIT (dBm)	PASS / FAIL
36	5180	38.392	15.84	30	PASS
40	5200	43.034	16.34	30	PASS
48	5240	46.648	16.69	30	PASS



FOR CHAIN 0: CH 36

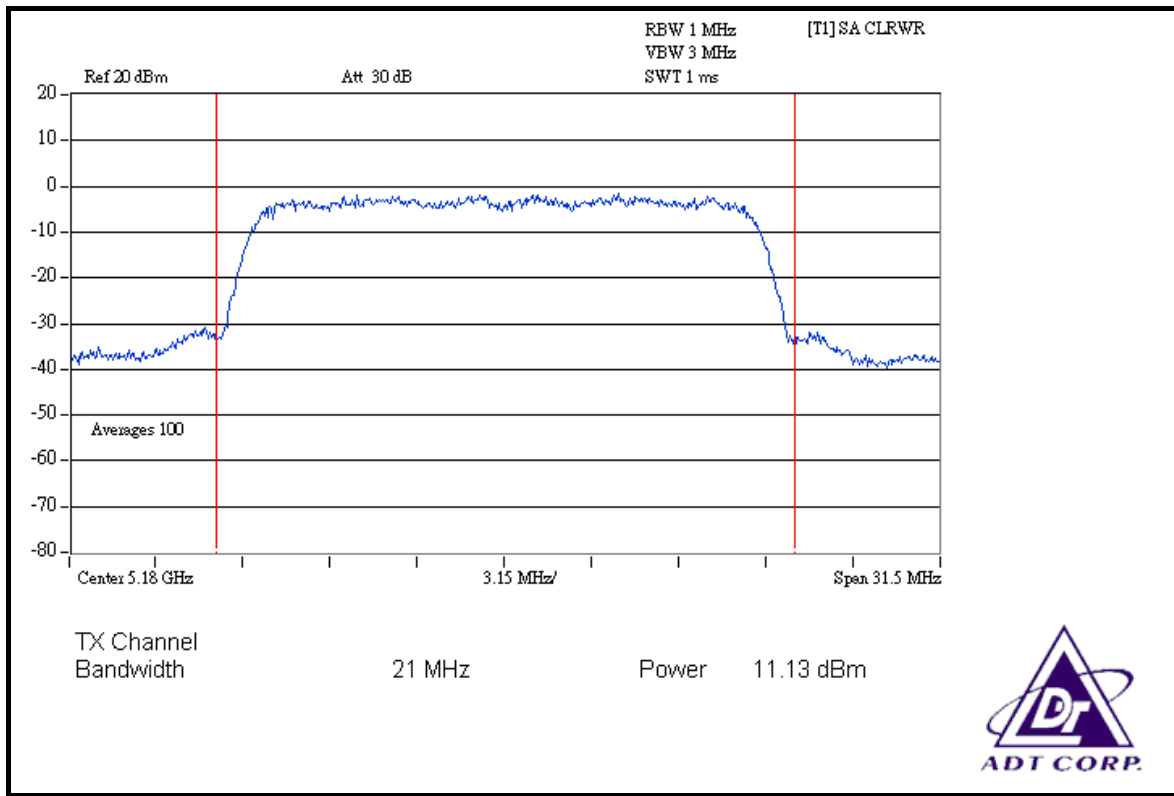

FOR CHAIN 0: CH 40

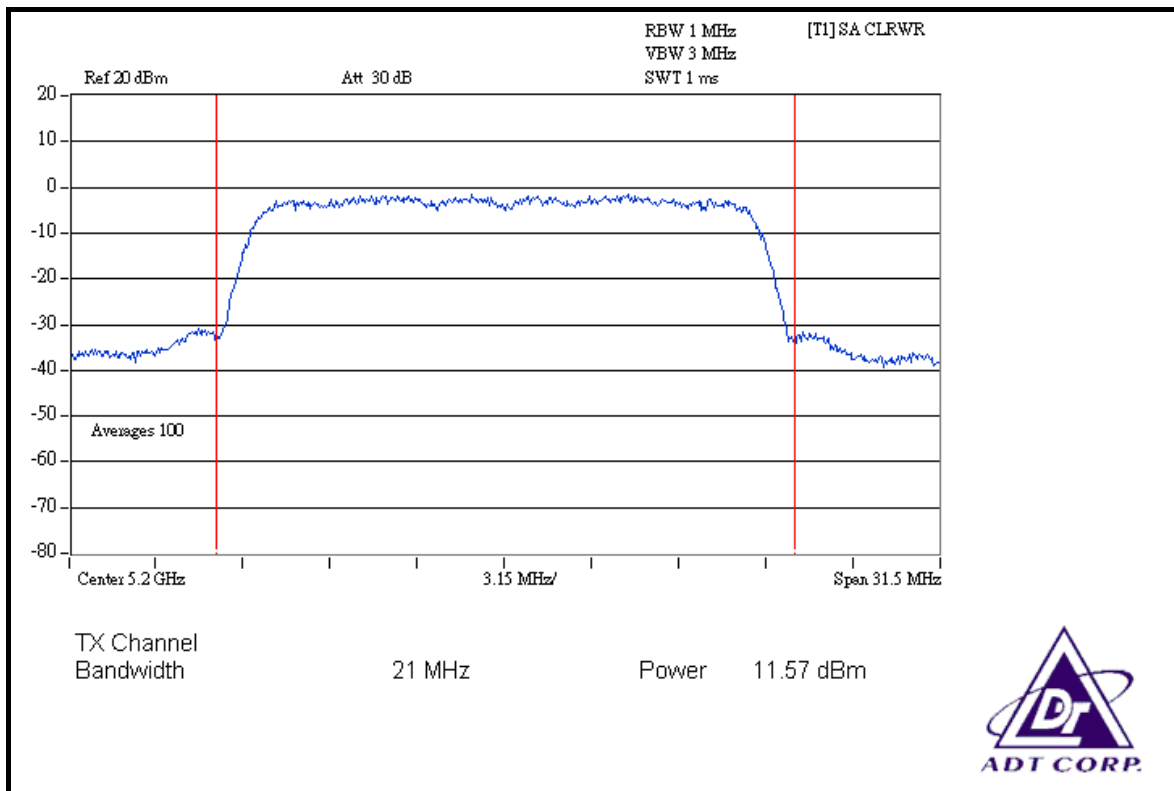



FOR CHAIN 0: CH 48

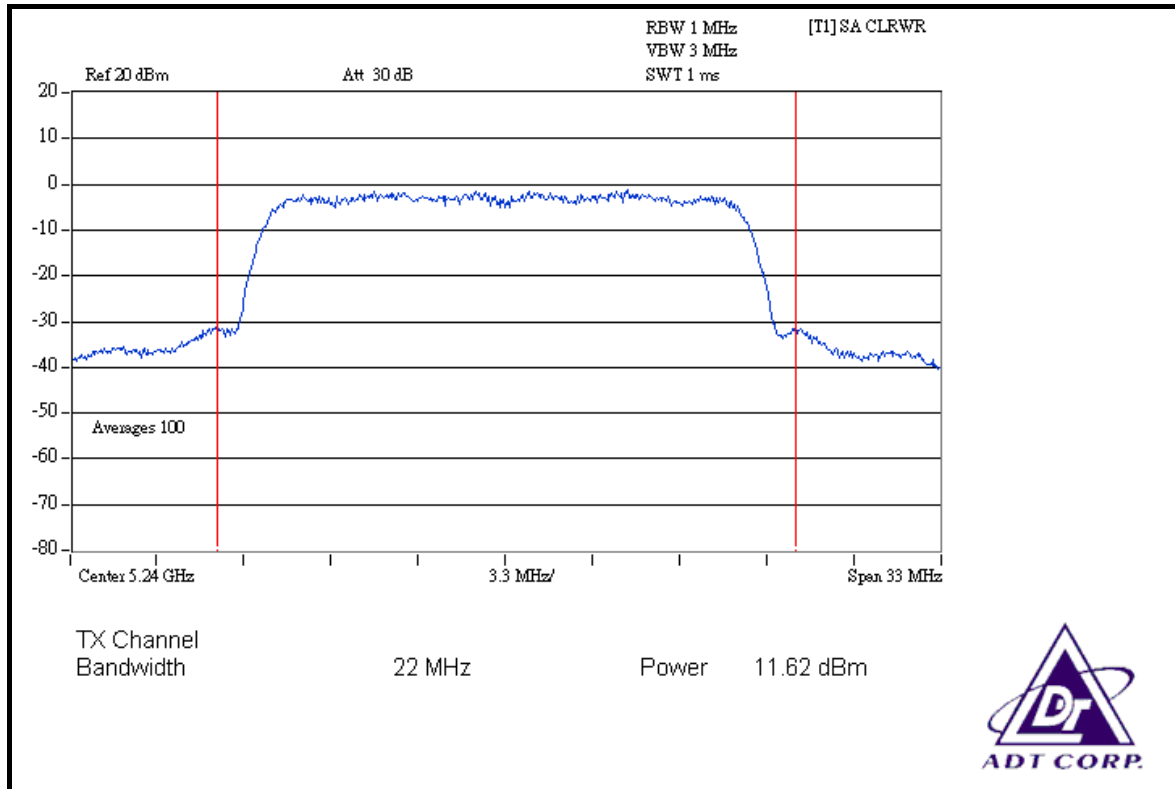

FOR CHAIN 1: CH 36

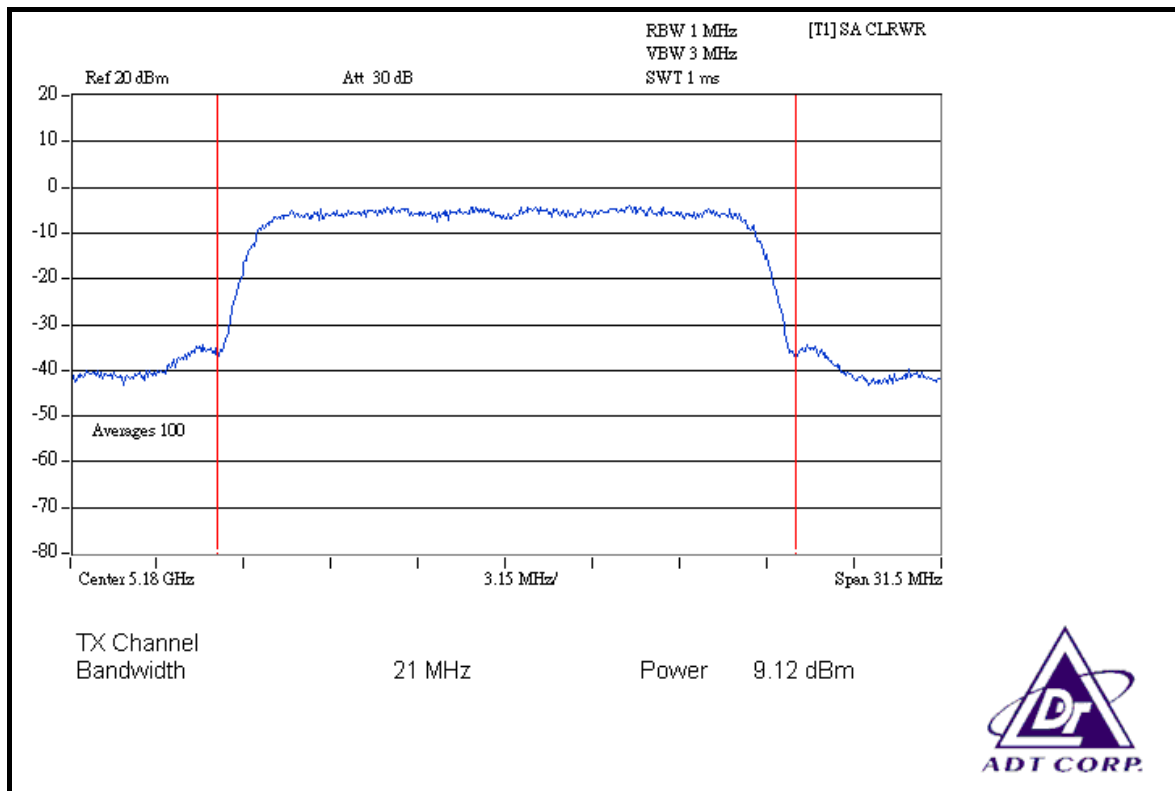

FOR CHAIN 1: CH 40

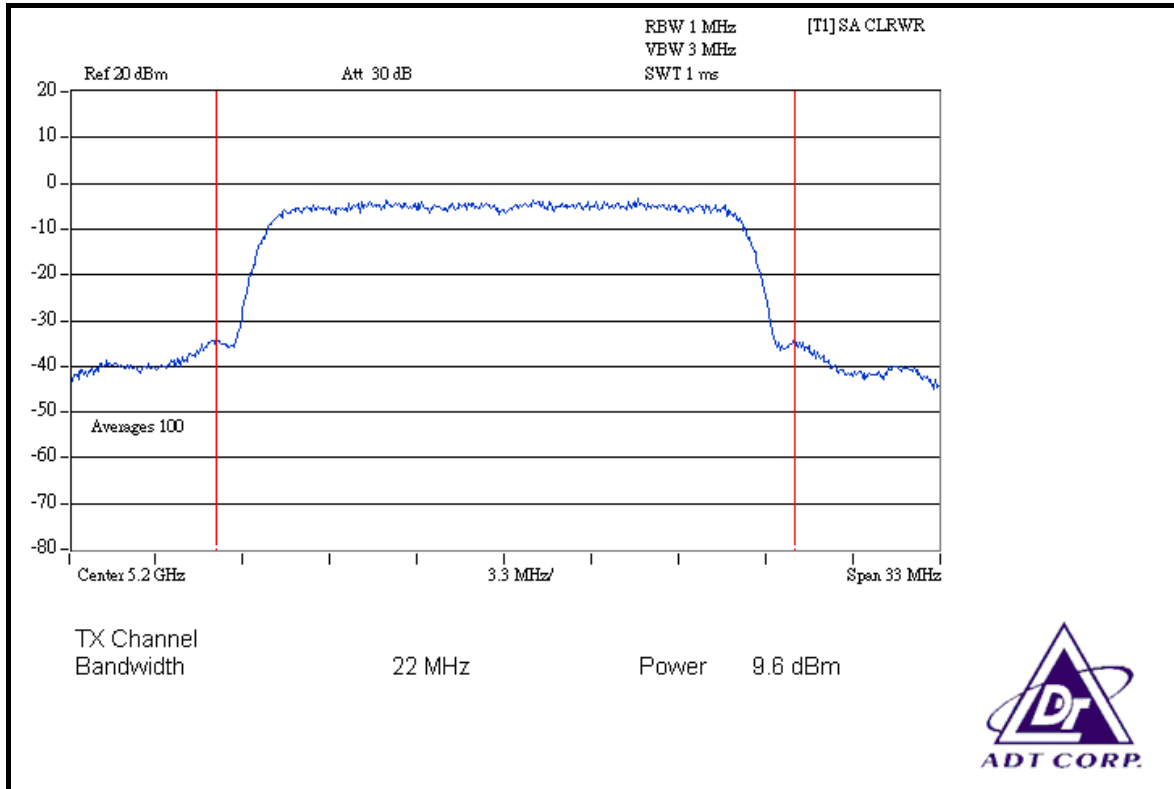

FOR CHAIN 1: CH 48

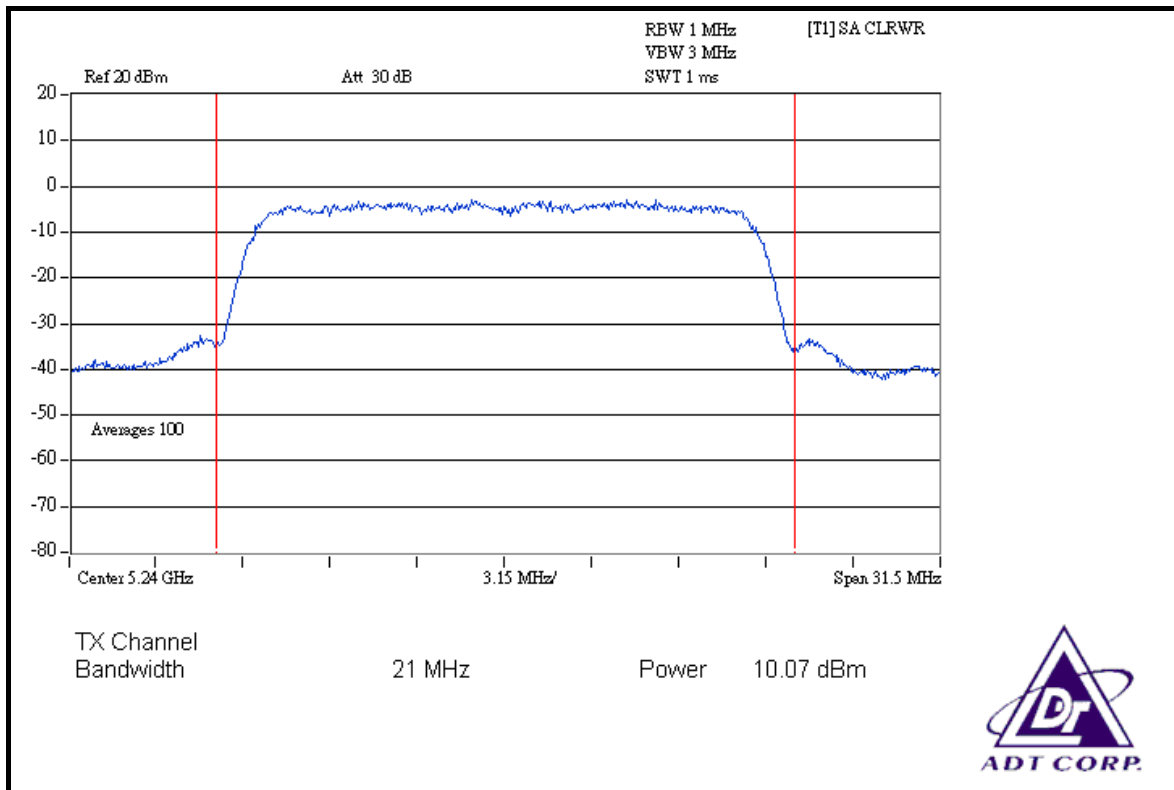



FOR CHAIN 2: CH 36

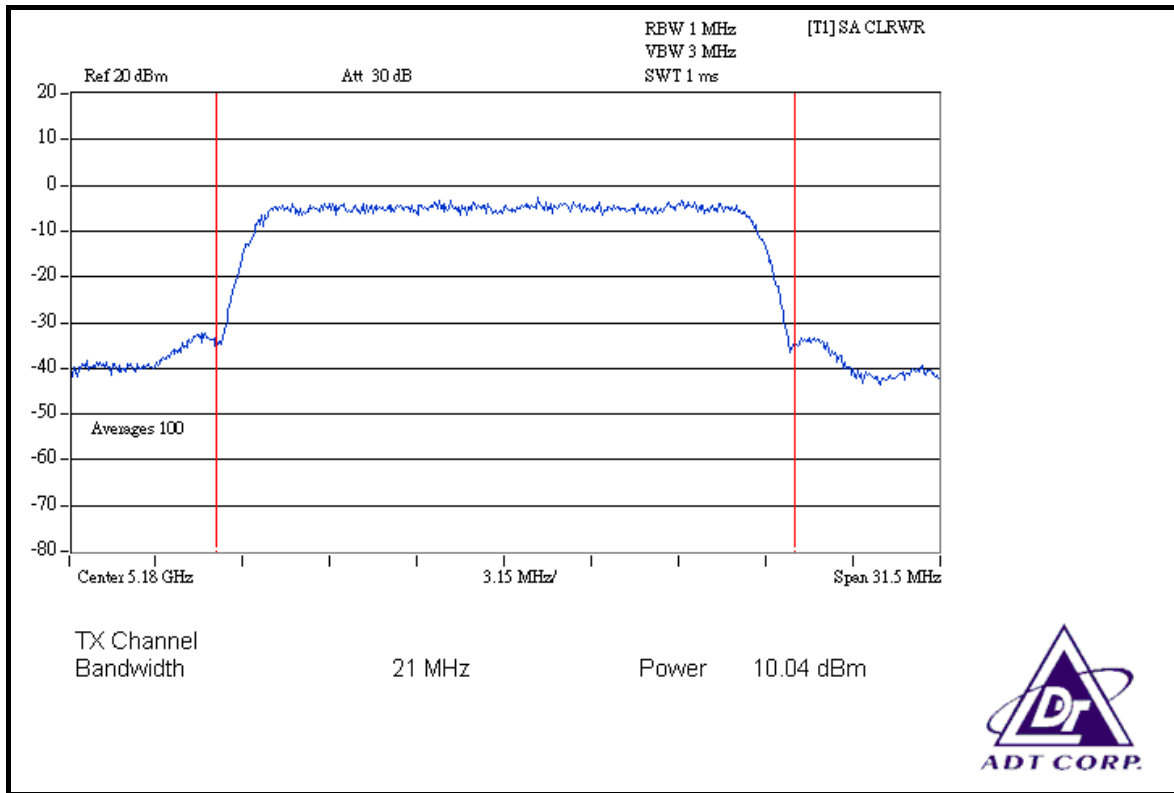

FOR CHAIN 2: CH 40

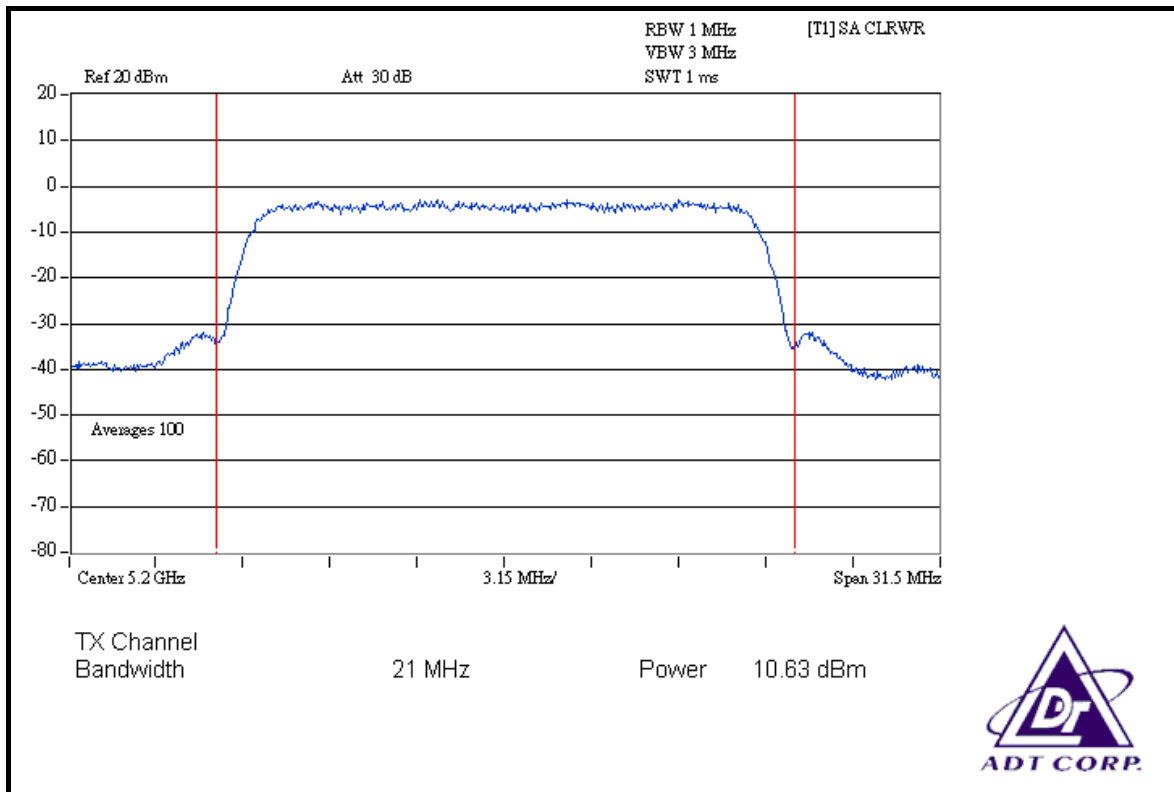



FOR CHAIN 2: CH 48



FOR CHAIN 3: CH 36

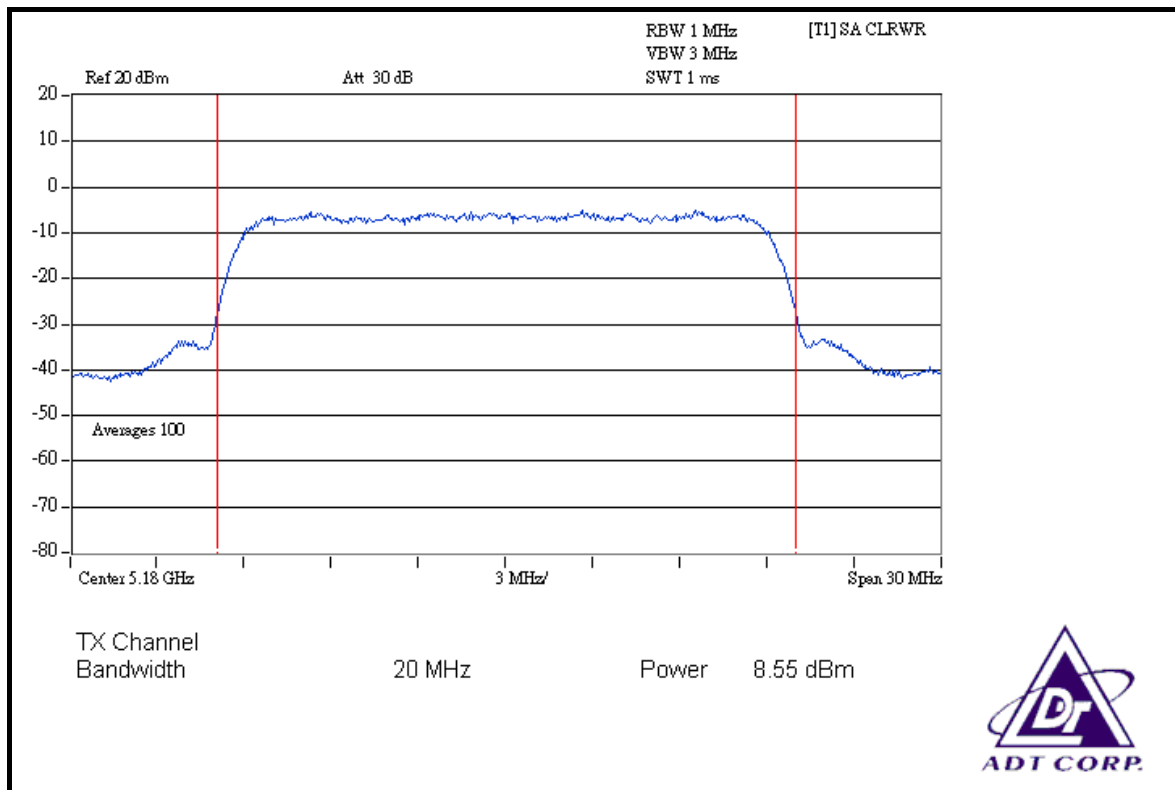



FOR CHAIN 3: CH 40

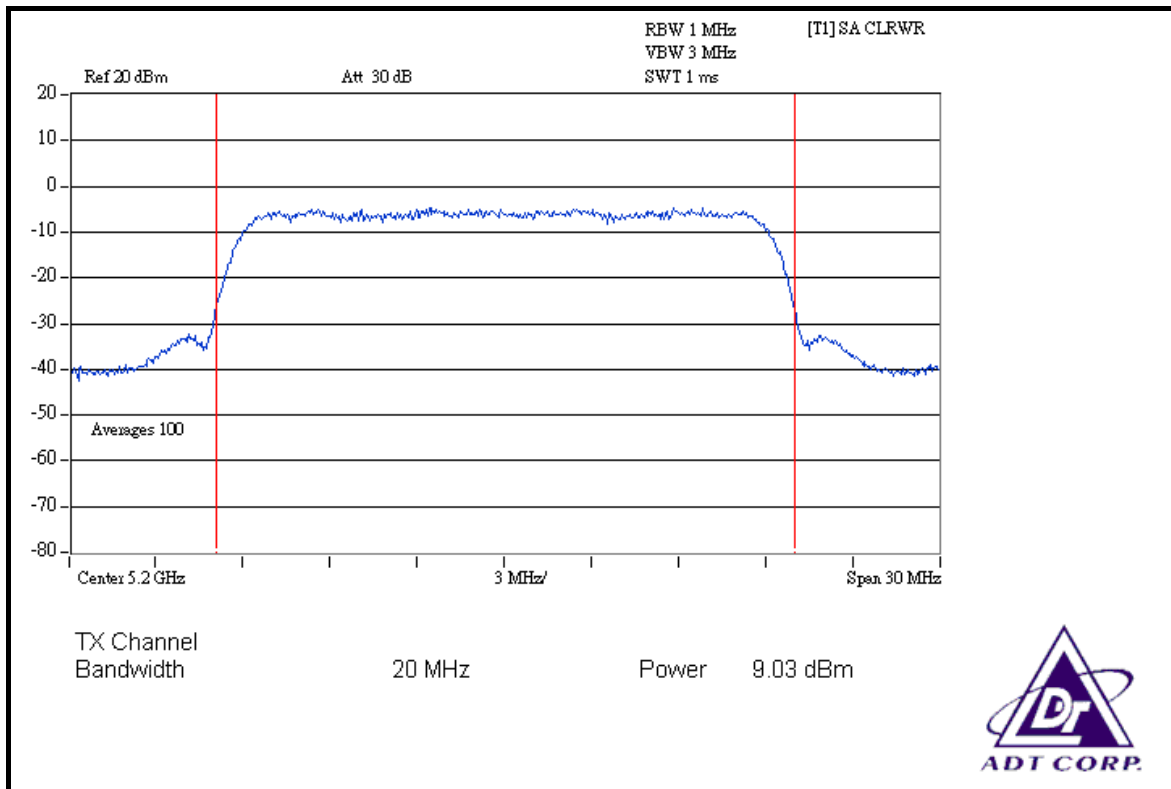

FOR CHAIN 3: CH 48

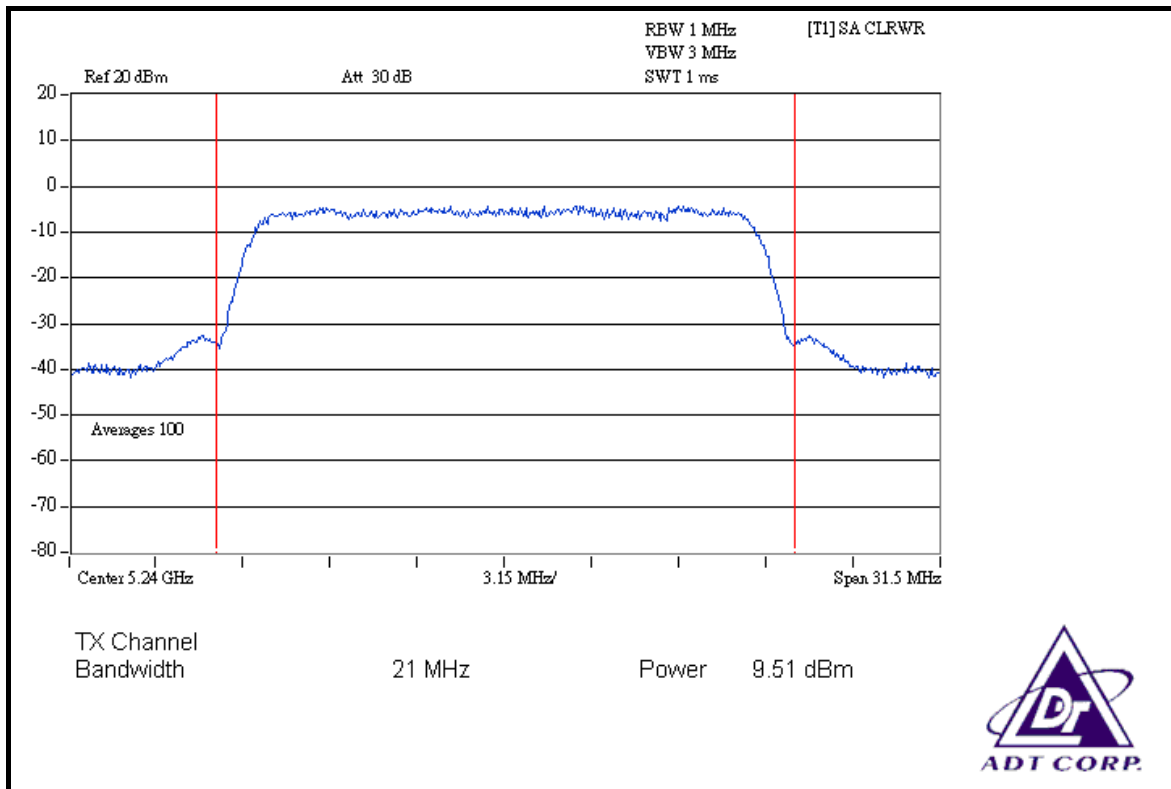



26dB OCCUPIED BANDWIDTH: 802.11a OFDM MODULATION

MODULATION TYPE	AMIMON Proprietary	TRANSFER RATE	6.0Mbps
INPUT POWER (SYSTEM)	120Vac, 60Hz	ENVIRONMENTAL CONDITIONS	27 deg.C, 66 %RH, 991hPa
TESTED BY	Dean Wang		

CHANNEL	CHANNEL FREQUENCY (MHz)	26dBc OCCUPIED BANDWIDTH (MHz)				PASS / FAIL
		CHAIN 0	CHAIN 1	CHAIN 2	CHAIN 3	
36	5180	20.16	20.05	20.20	19.85	PASS
40	5200	20.77	21.54	21.00	19.96	PASS
48	5240	21.16	20.37	20.35	20.93	PASS

FOR CHAIN 0: CH 36

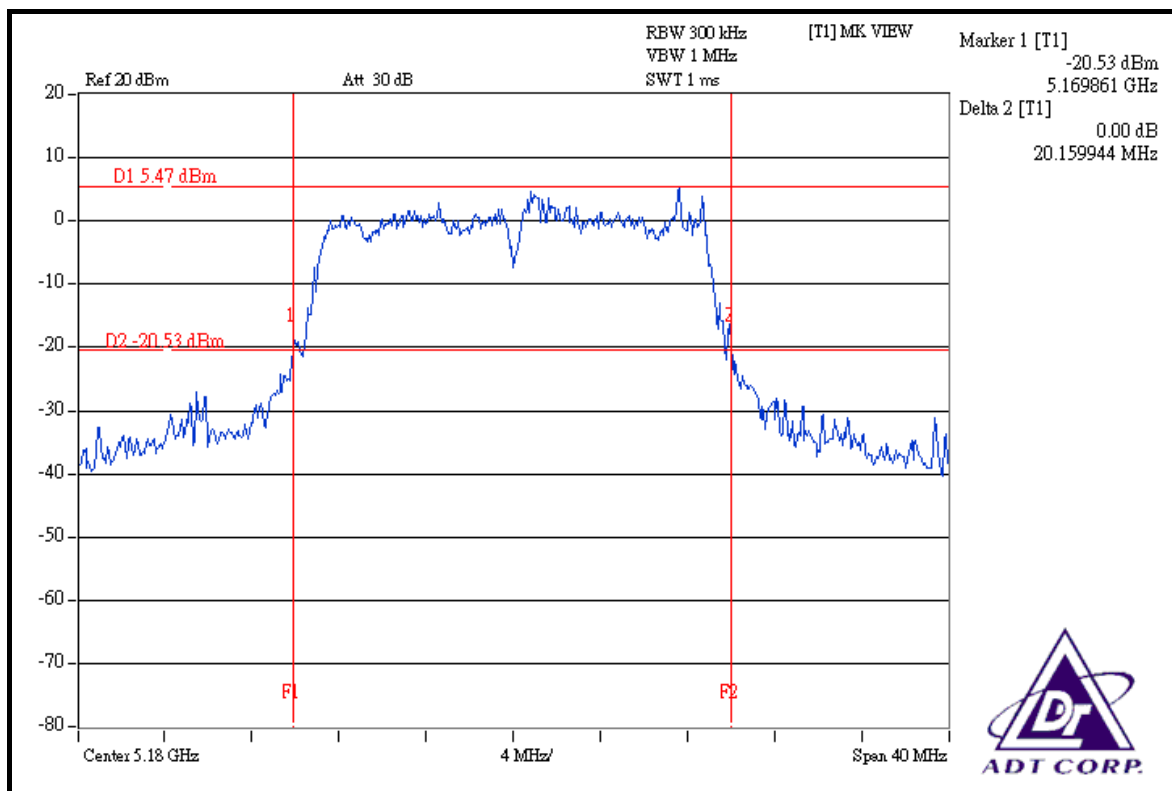



FOR CHAIN 0: CH 40

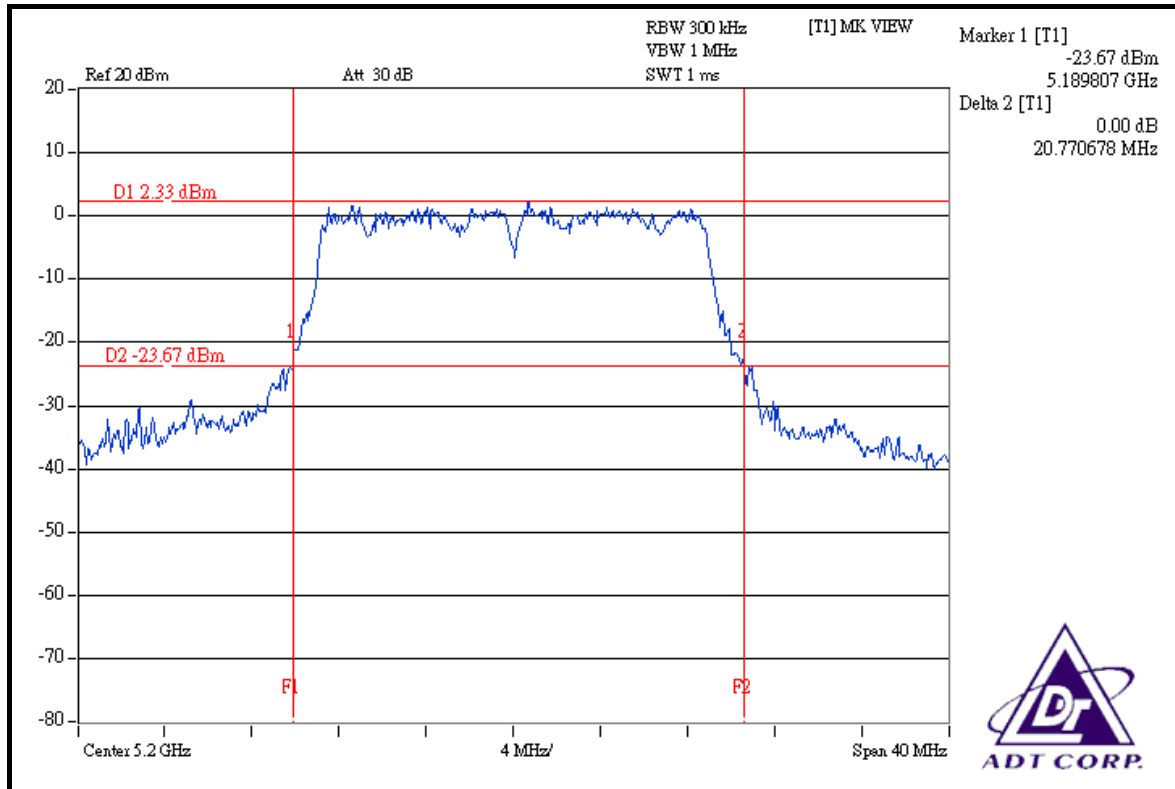

FOR CHAIN 0: CH 48

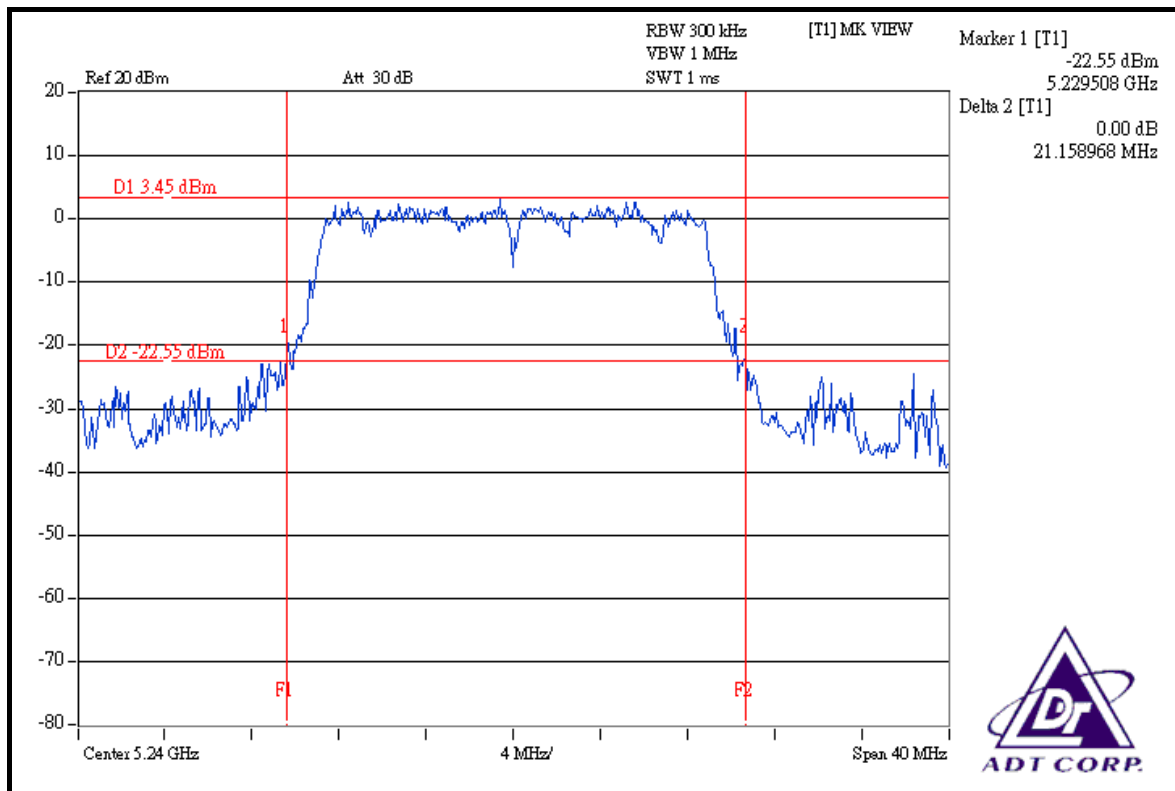



FOR CHAIN 1: CH 36

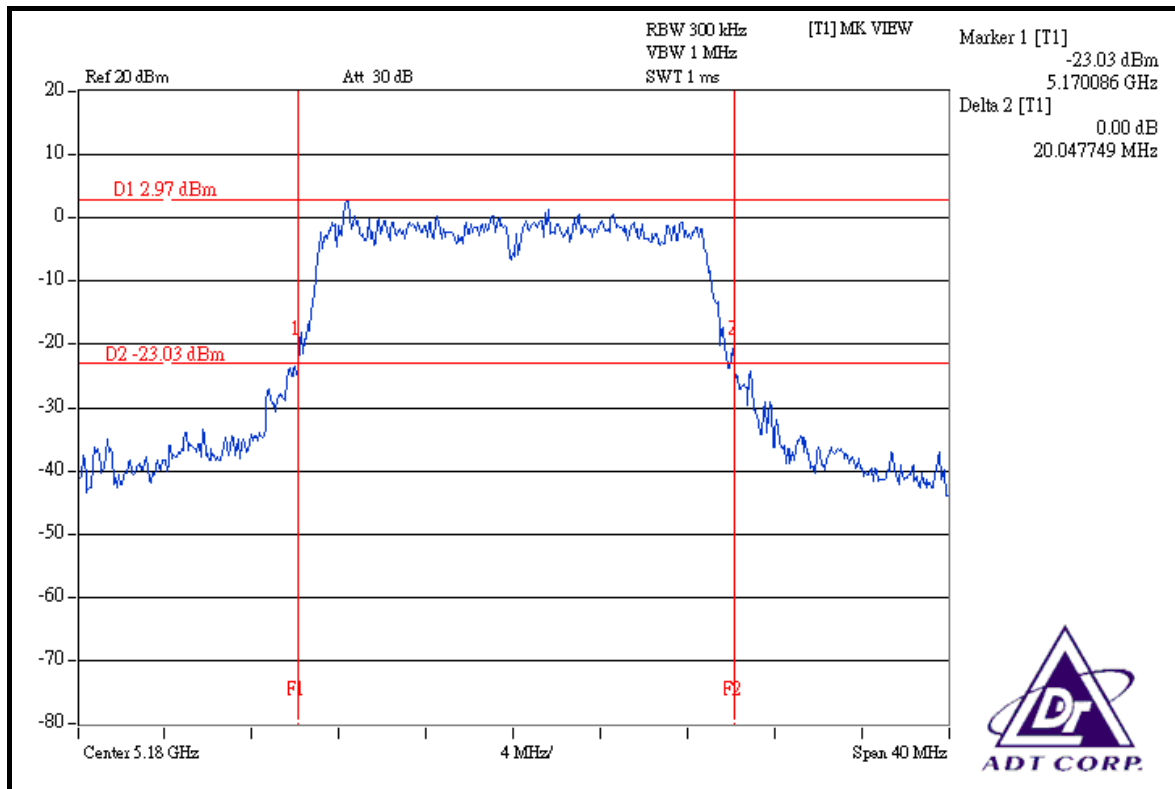

FOR CHAIN 1: CH 40

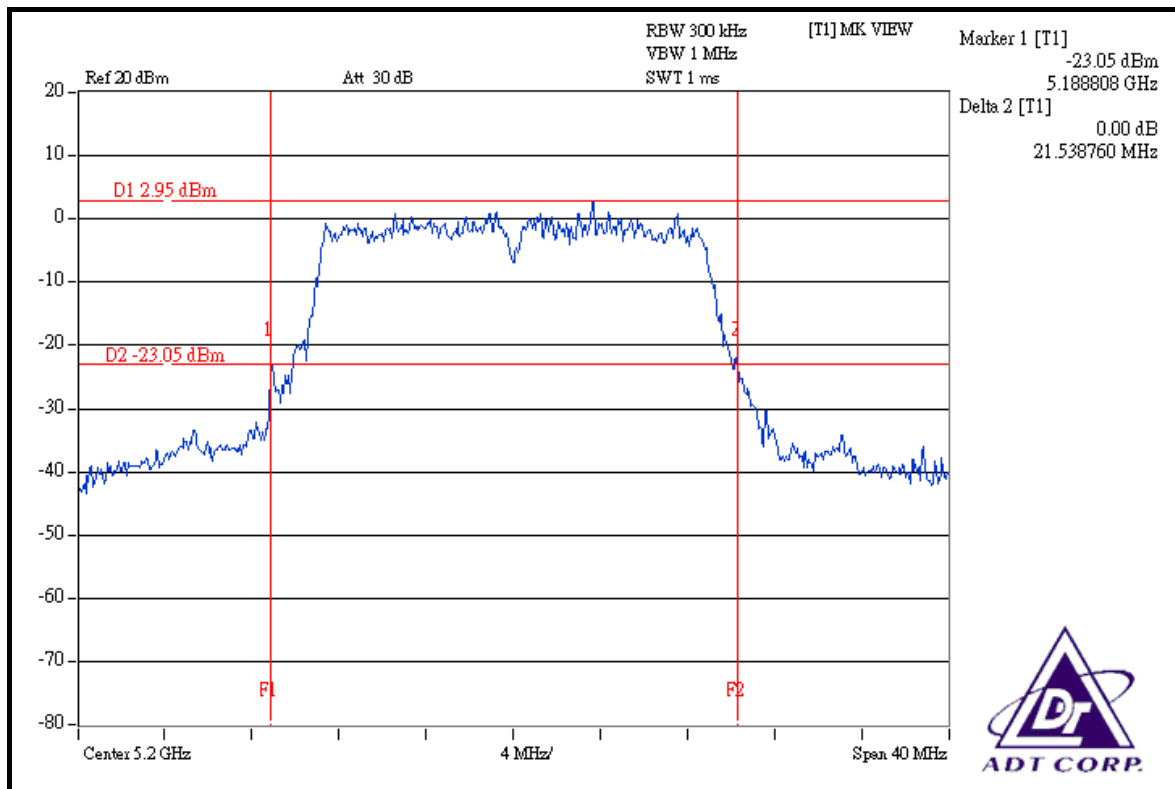

FOR CHAIN 1: CH 48

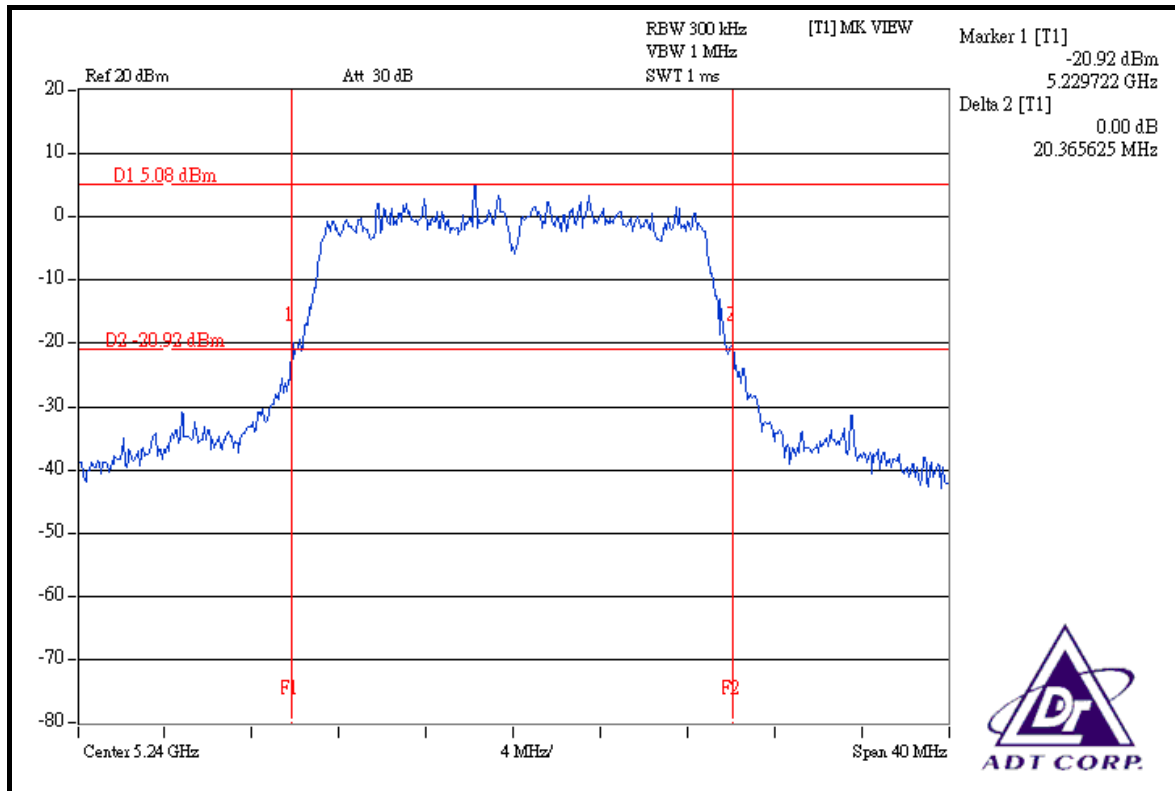

FOR CHAIN 2: CH 36

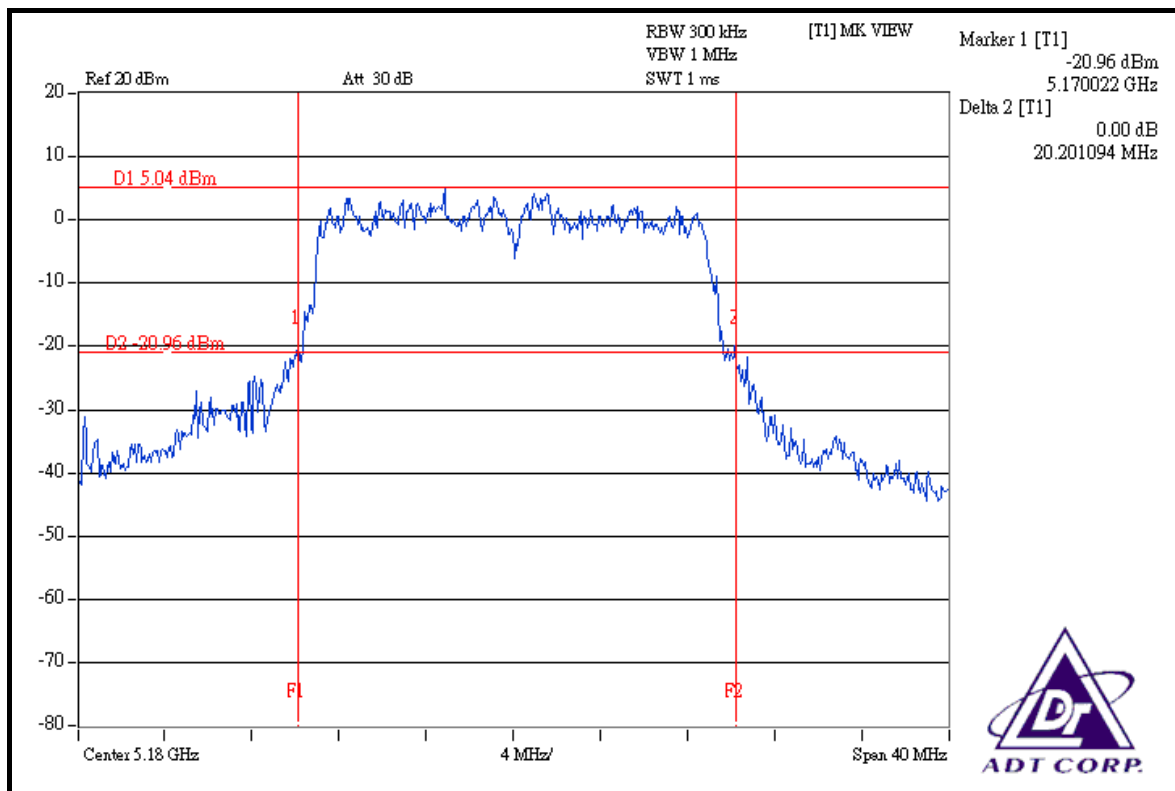



FOR CHAIN 2: CH 40

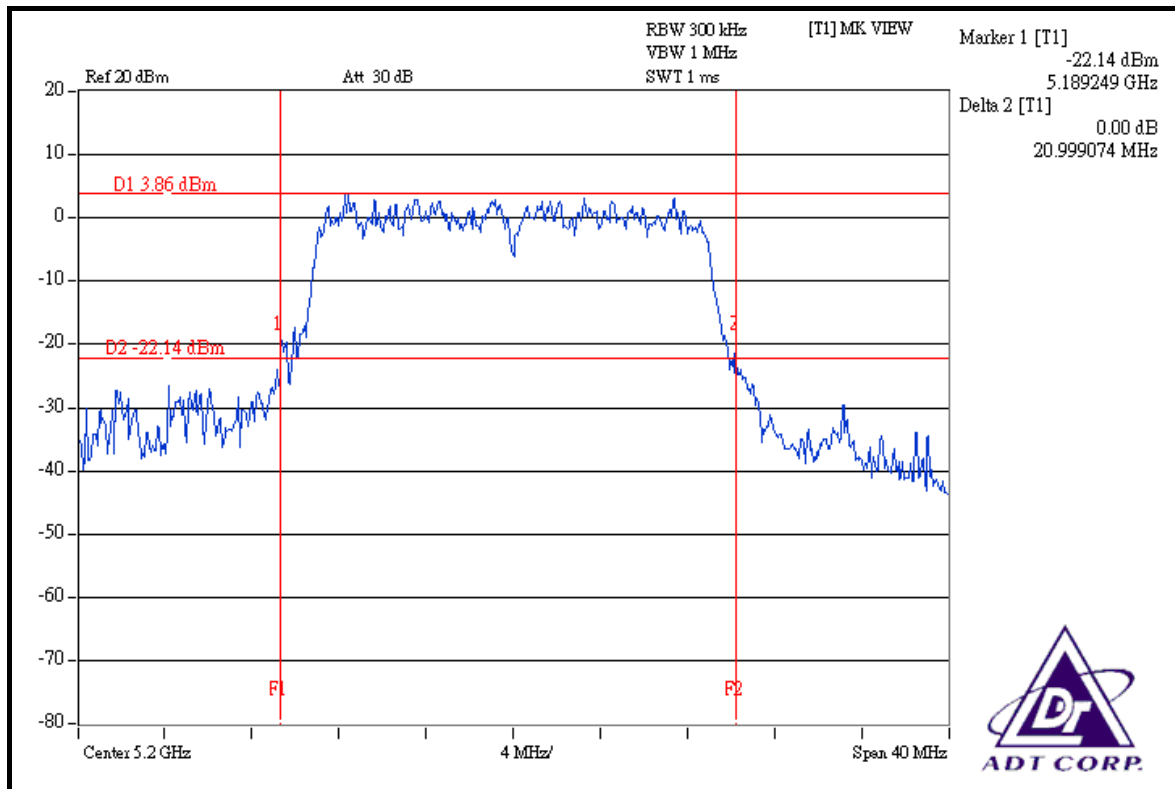

FOR CHAIN 2: CH 48

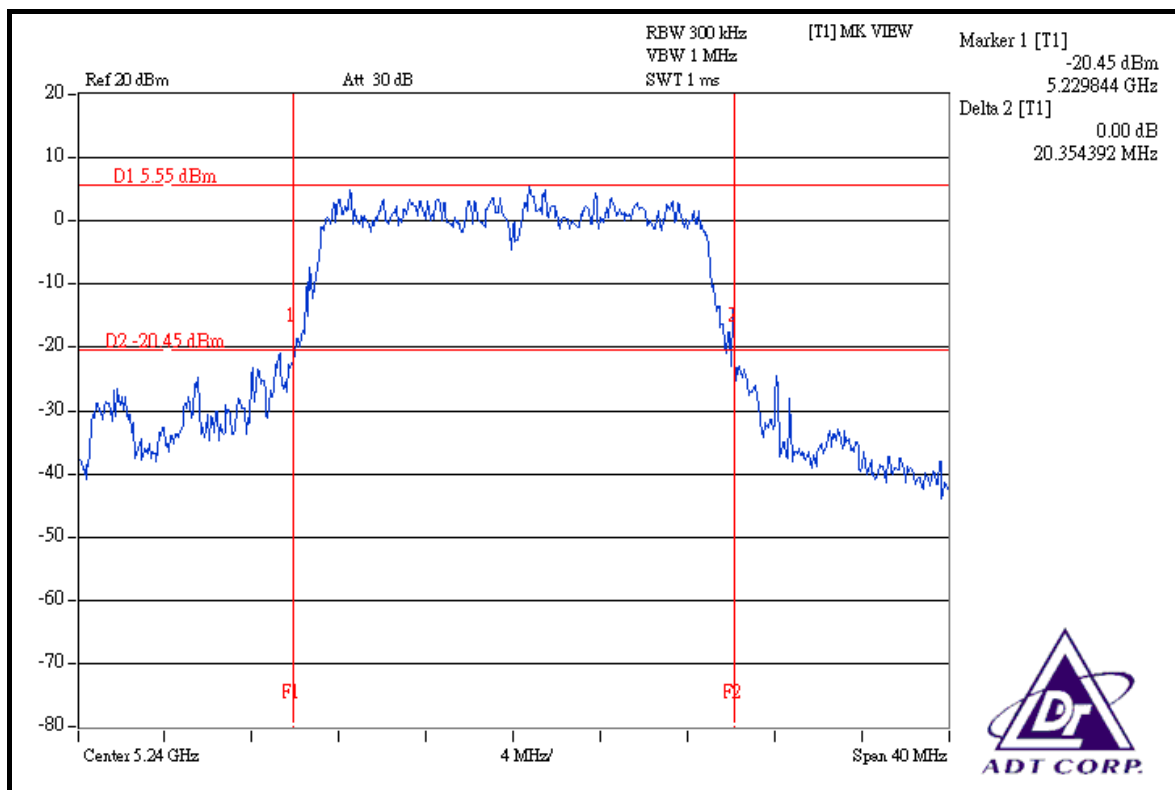



FOR CHAIN 3: CH 36

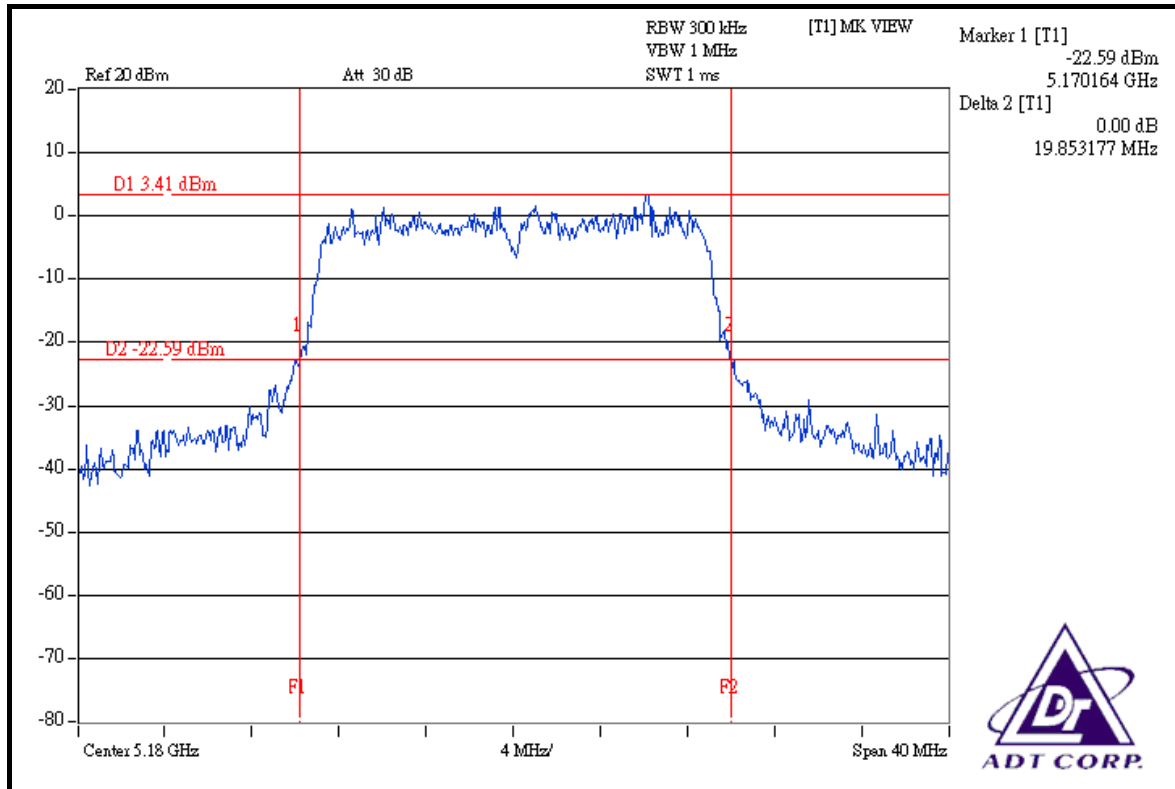

FOR CHAIN 3: CH 40

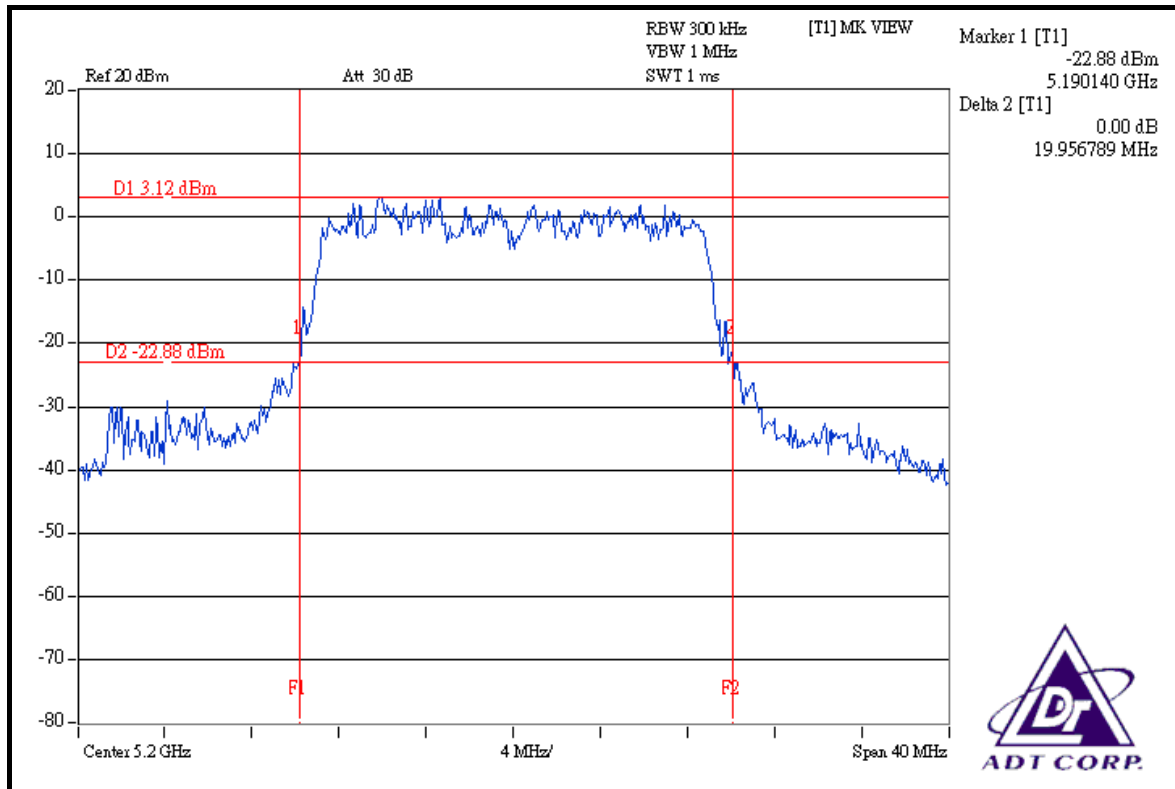



FOR CHAIN 3: CH 48

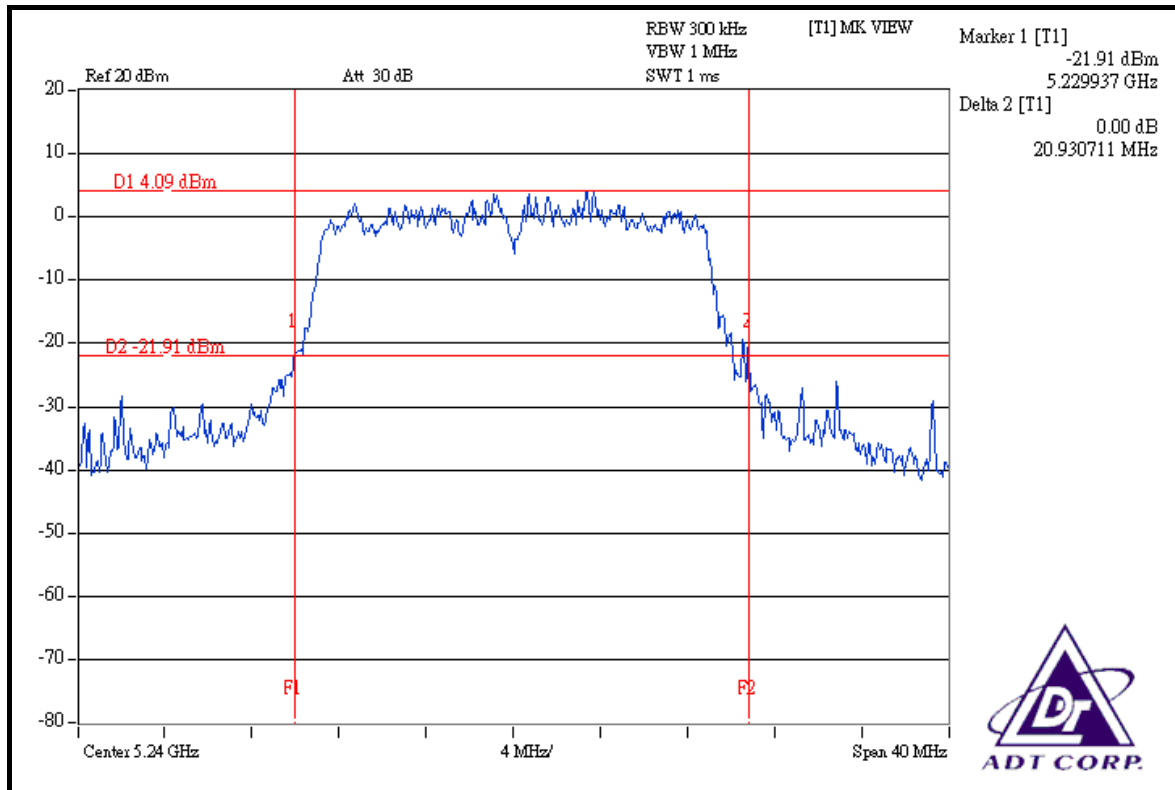



4.4 PEAK POWER EXCURSION MEASUREMENT

4.4.1 LIMITS OF PEAK POWER EXCURSION MEASUREMENT

FREQUENCY BAND	LIMIT
5.15 ~ 5.25GHz	13dB

4.4.2 TEST INSTRUMENTS

DESCRIPTION & MANUFACTURER	MODEL NO.	SERIAL NO.	CALIBRATED UNTIL
R&S SPECTRUM ANALYZER	FSP40	100040	Jun. 28, 2008

NOTE: The calibration interval of the above test instruments is 12 months and the calibrations are traceable to NML/ROC and NIST/USA.

4.4.3 TEST PROCEDURE

- a. The transmitter output was connected to the spectrum analyzer.
- b. Set the spectrum bandwidth span to view the entire spectrum.
- c. Using peak detector and Max-hold function for Trace 1 (RB = 1MHz, VB = 3MHz) and 2 (RB = 1MHz, VB = 300kHz).
- d. The largest difference between Trace 1 and Trace 2 in any 1MHz band on any frequency was recorded.

4.4.4 DEVIATION FROM TEST STANDARD

No deviation

4.4.5 TEST SETUP

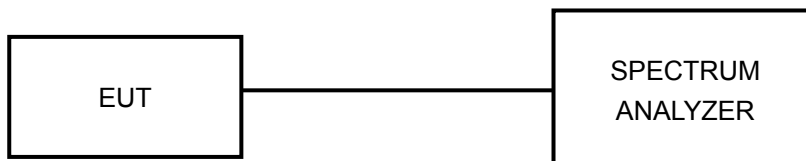

4.4.6 EUT OPERATING CONDITIONS

The software provided by client to enable the EUT under transmission condition continuously at specific channel frequencies individually.



4.4.7 TEST RESULTS

802.11a OFDM MODULATION

MODULATION TYPE	AMIMON Proprietary	TRANSFER RATE	6.0Mbps
INPUT POWER (SYSTEM)	120Vac, 60Hz	ENVIRONMENTAL CONDITIONS	27 deg.C, 66 %RH, 991hPa
TESTED BY	Dean Wang		

CHANNEL	CHANNEL FREQUENCY (MHz)	PEAK POWER EXCURSION (dB)				PEAK TO AVERAGE EXCURSION LIMIT (dB)	PASS / FAIL
		CHAIN 0	CHAIN 1	CHAIN 2	CHAIN 3		
36	5180	9.83	9.87	11.55	10.42	13	PASS
40	5200	9.87	9.88	11.47	10.72	13	PASS
48	5240	9.96	8.94	12.11	10.81	13	PASS

FOR CHAIN 0: CH 36

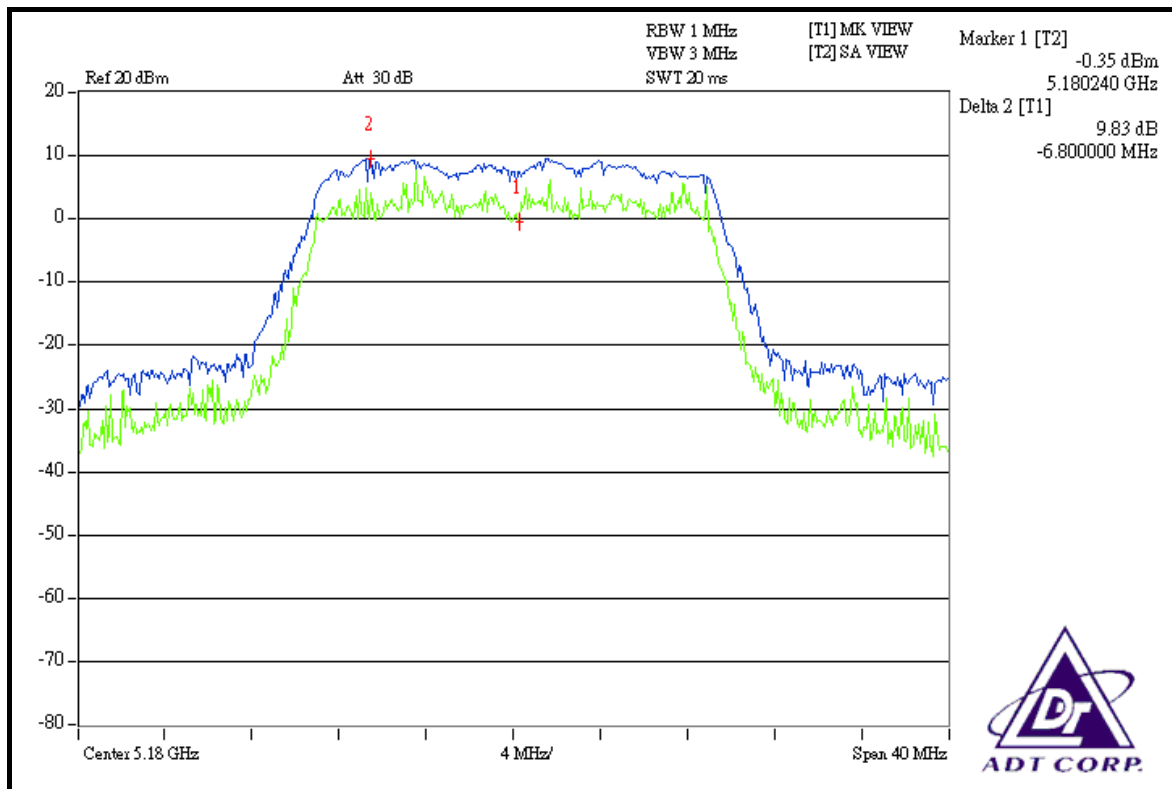



FOR CHAIN 0: CH 40

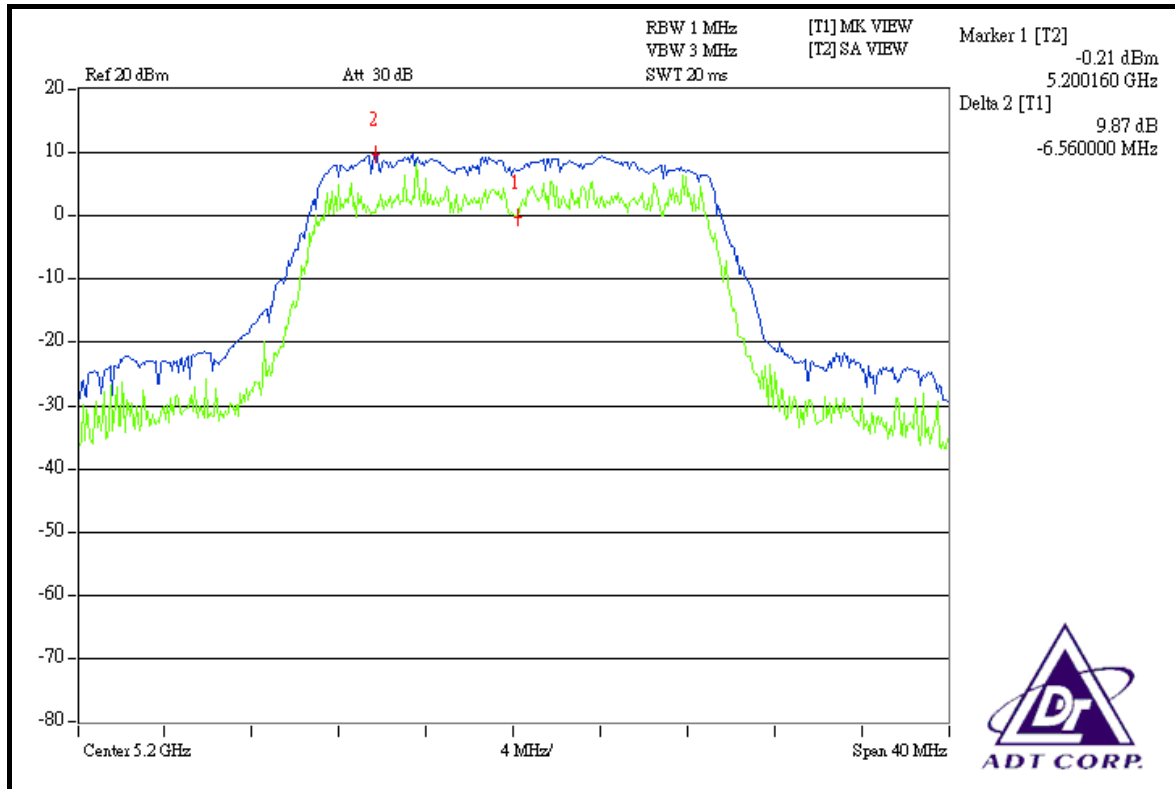

FOR CHAIN 0: CH 48

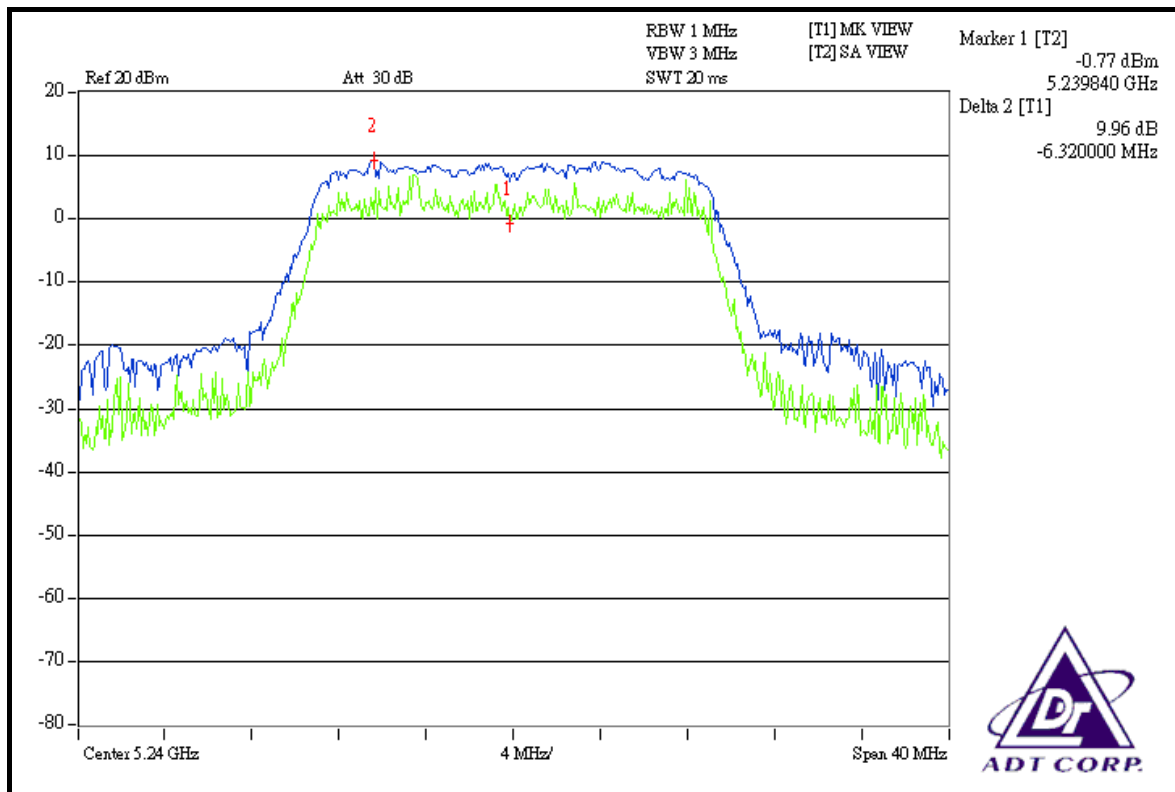



FOR CHAIN 1: CH 36

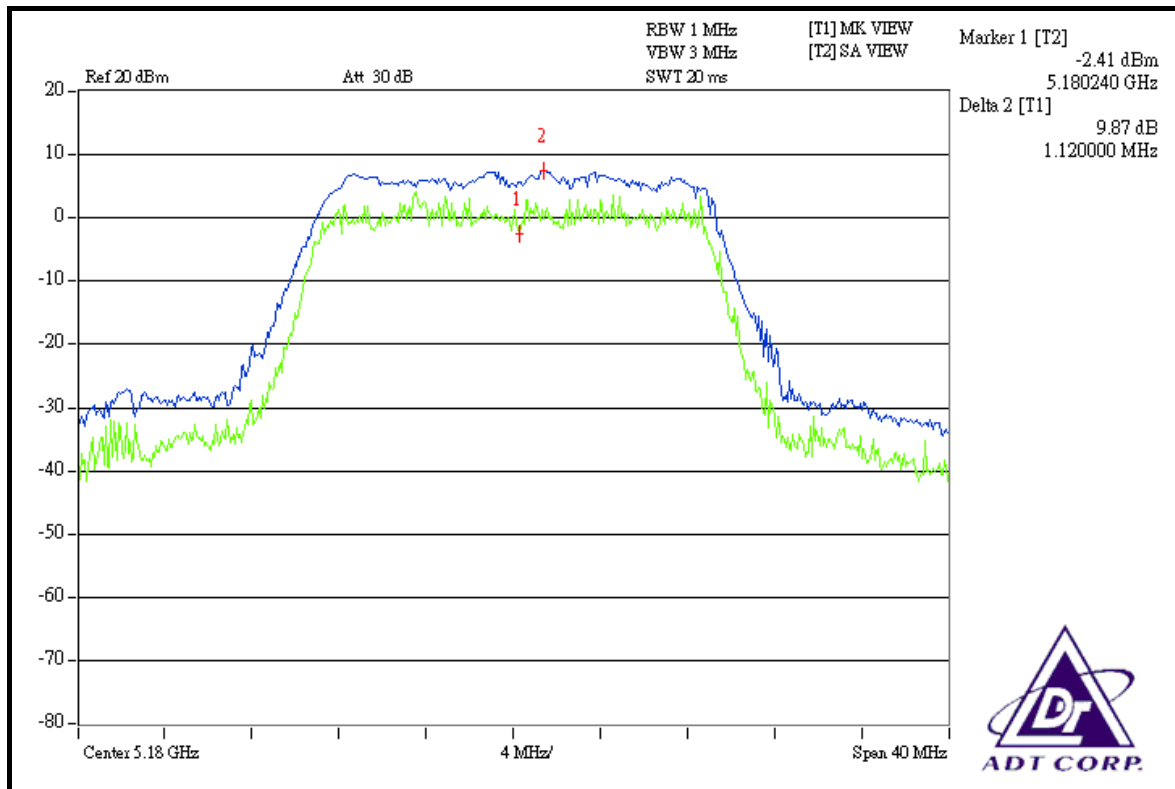

FOR CHAIN 1: CH 40

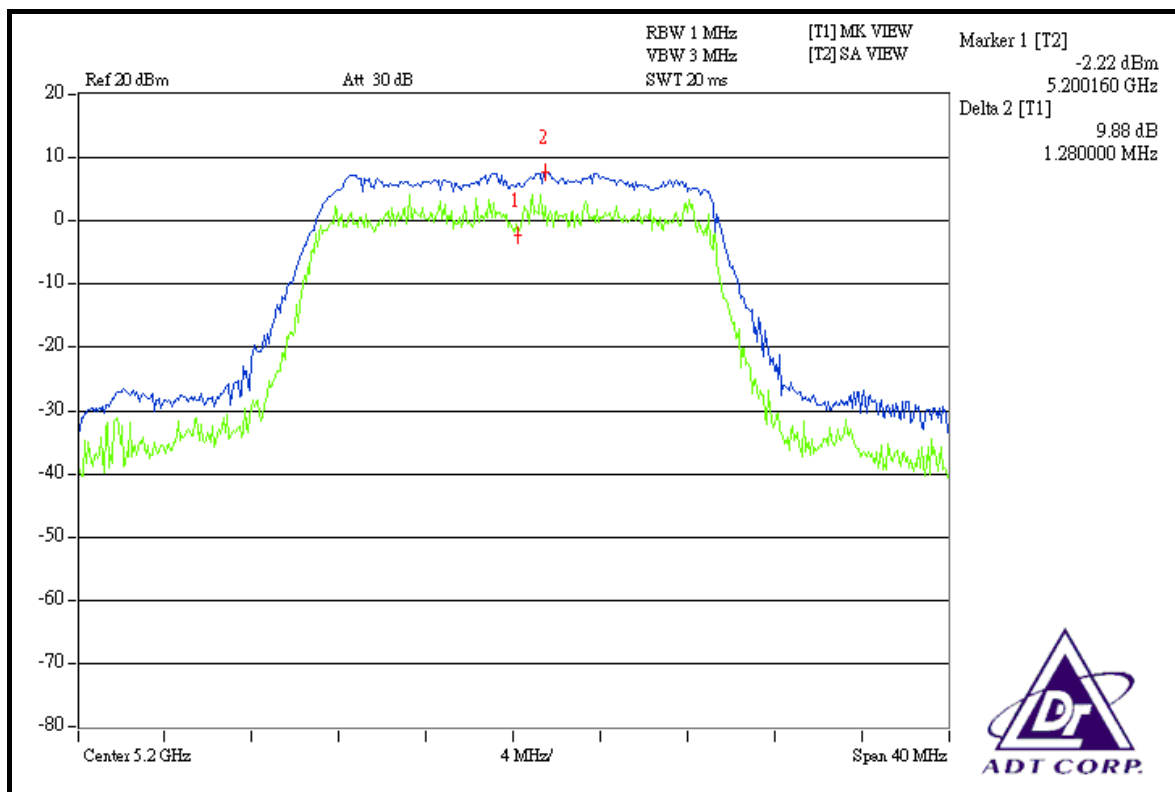



FOR CHAIN 1: CH 48

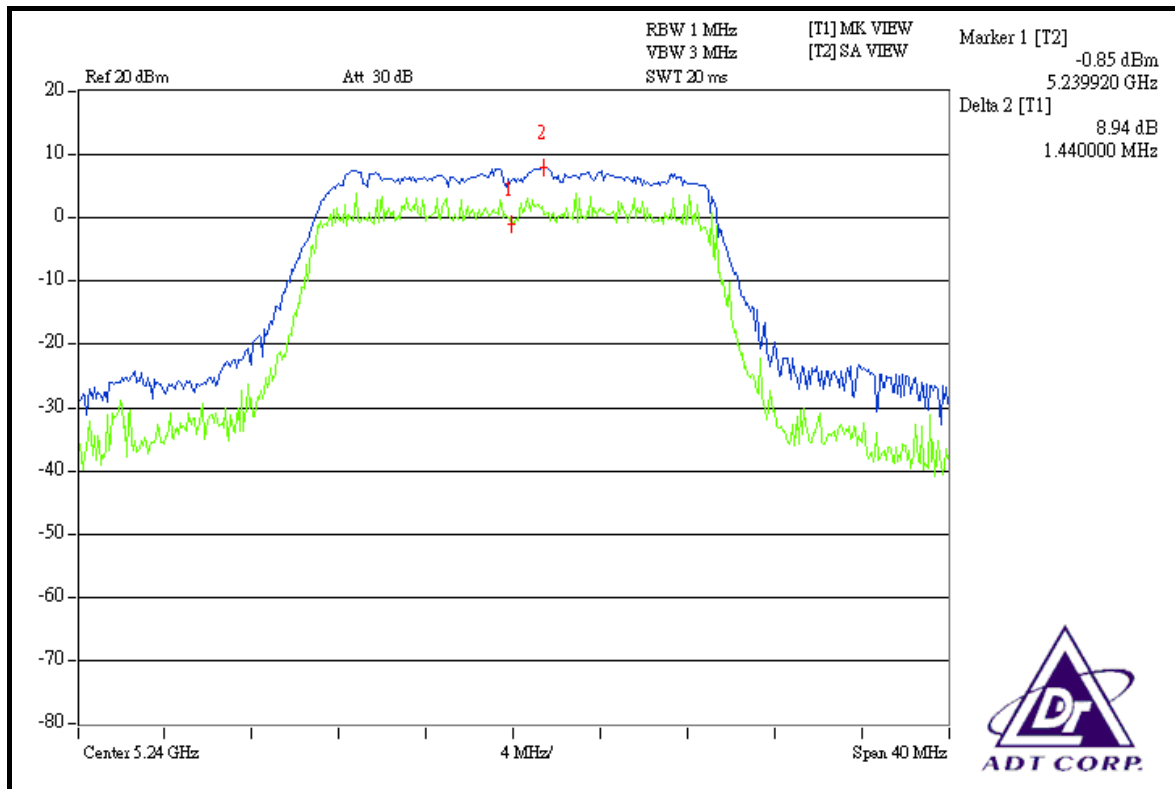

FOR CHAIN 2: CH 36

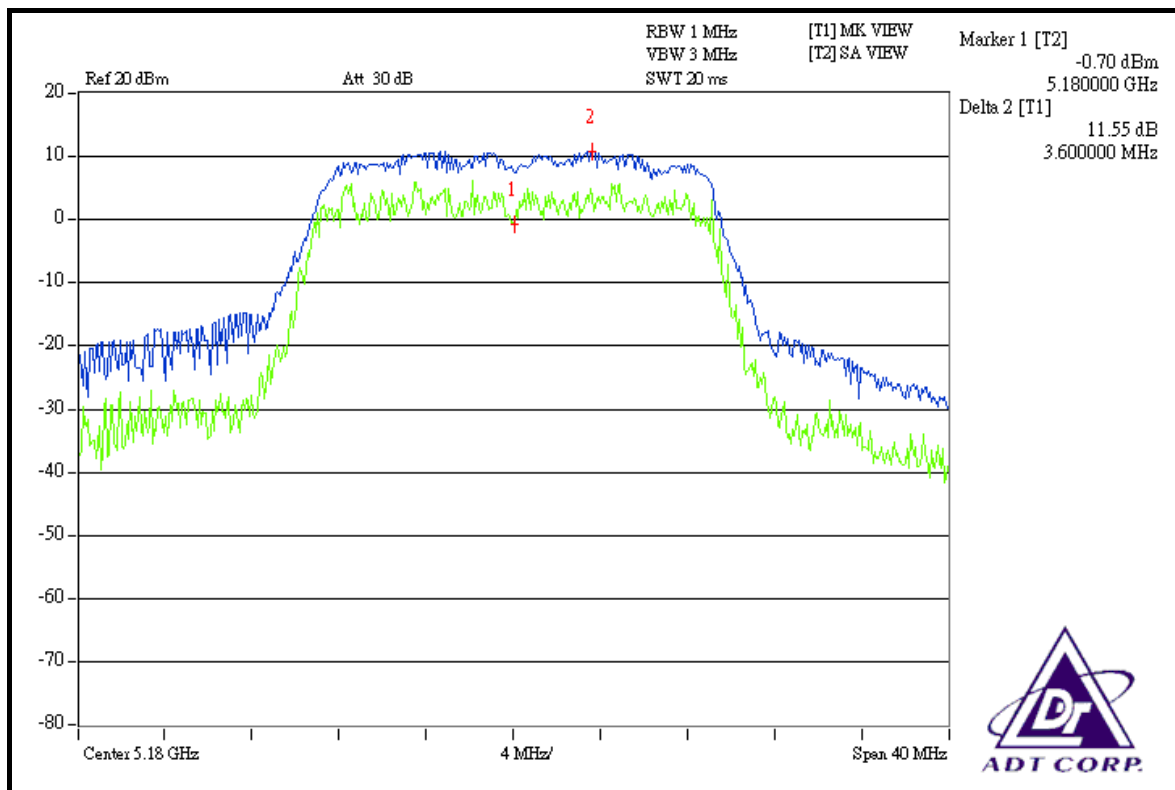



FOR CHAIN 2: CH 40

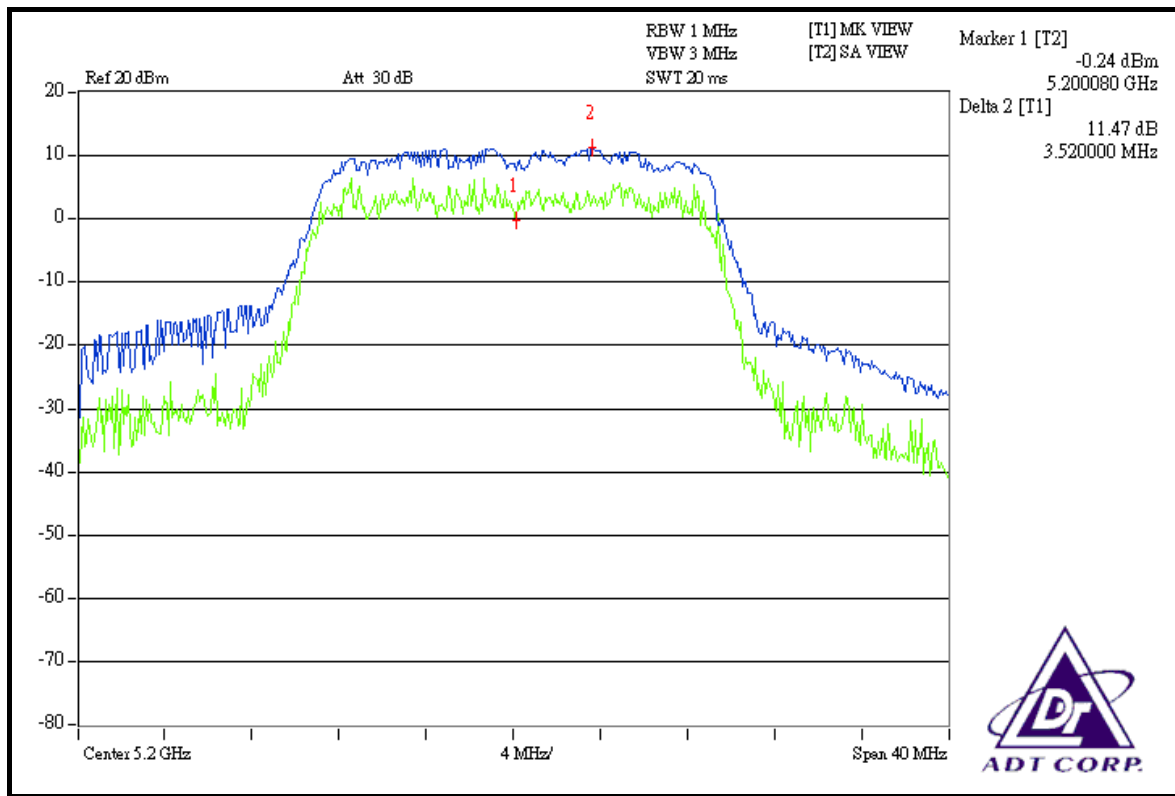

FOR CHAIN 2: CH 48

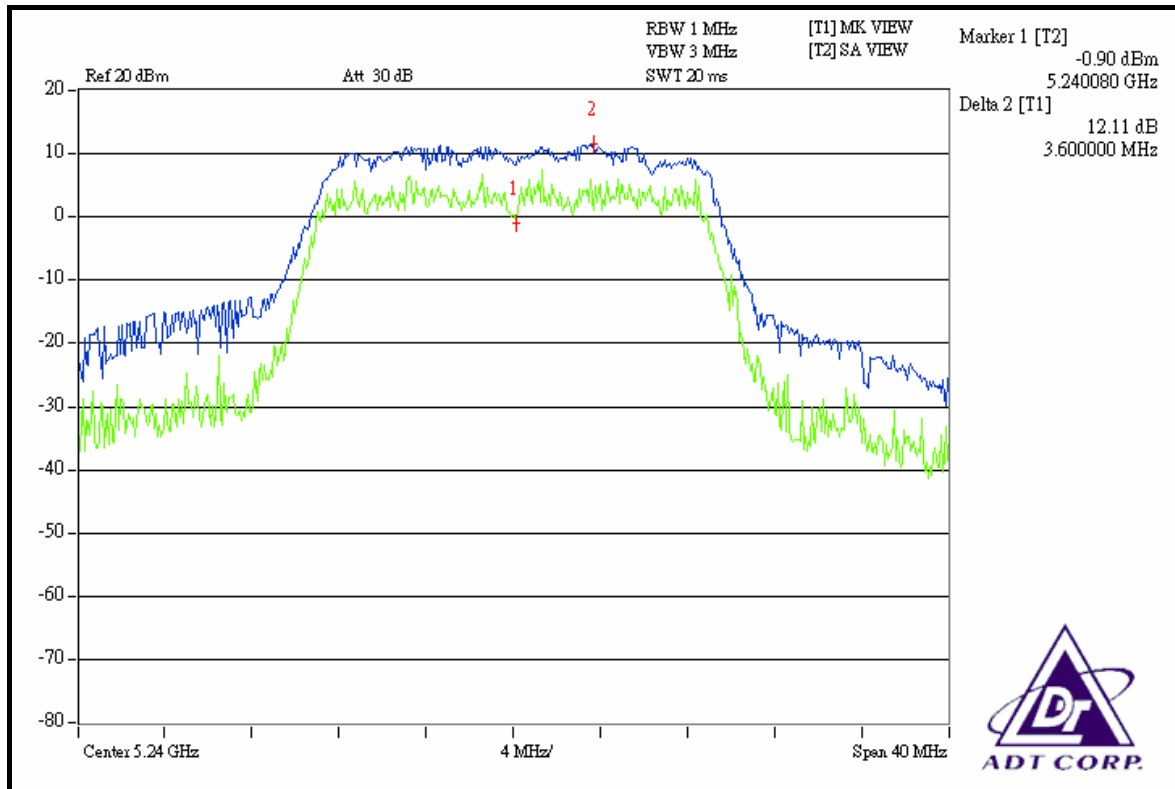



FOR CHAIN 3: CH 36

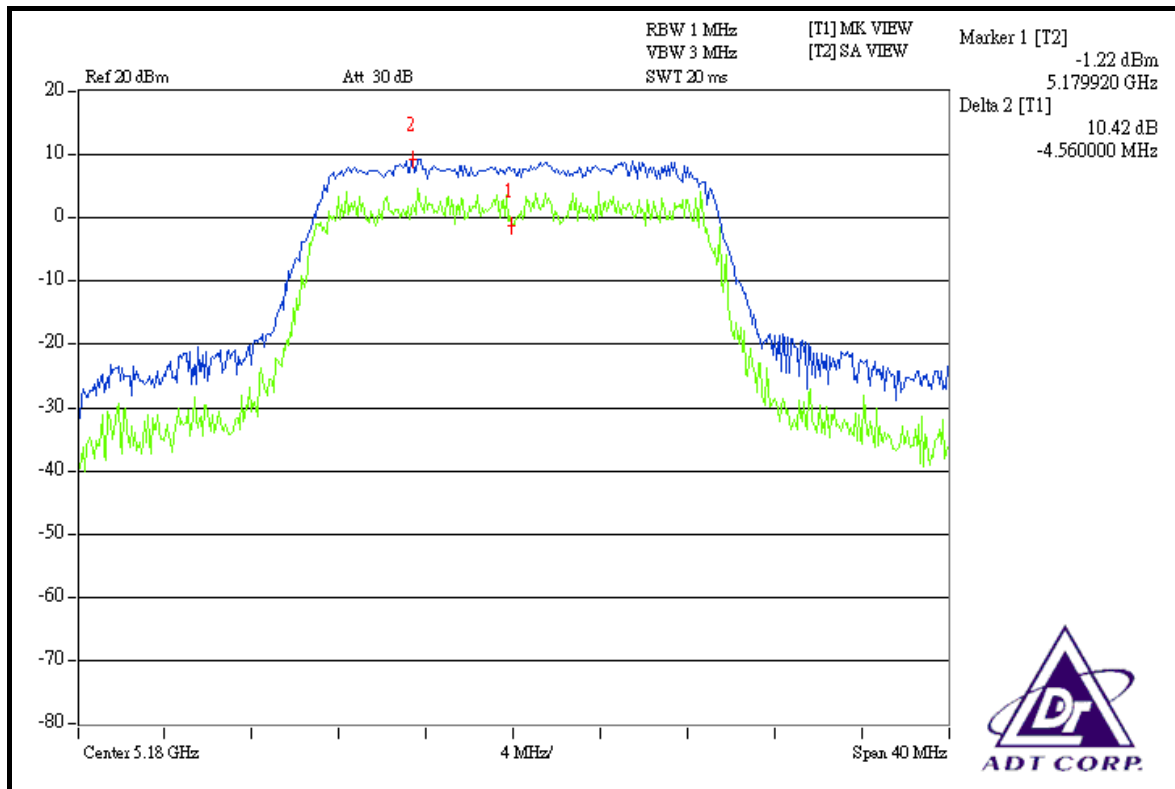

FOR CHAIN 3: CH 40

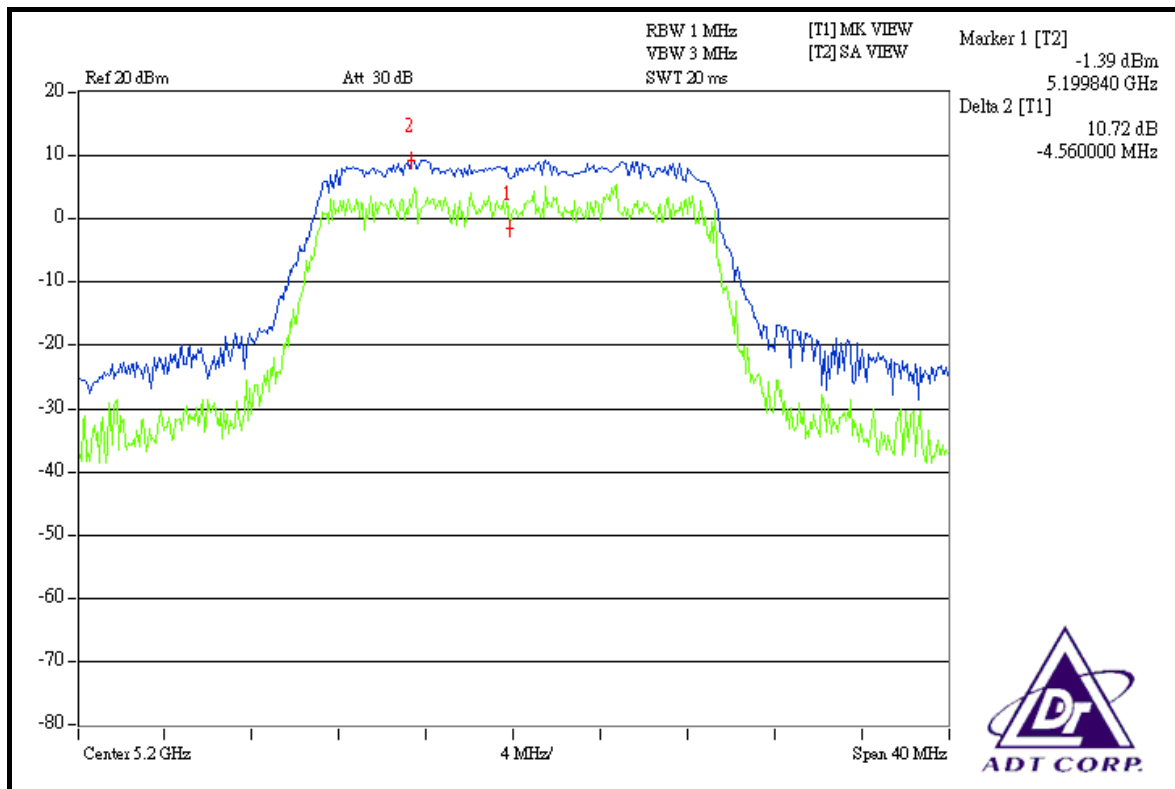



FOR CHAIN 3: CH 48

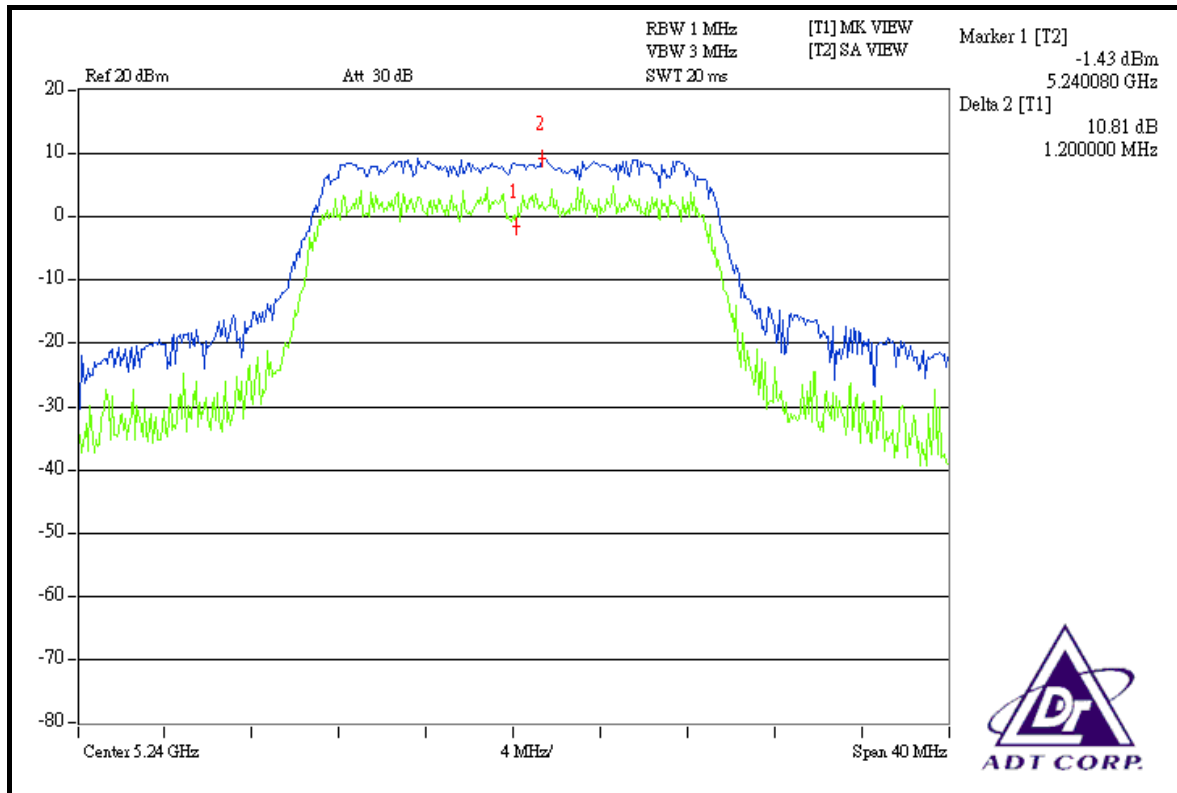



4.5 PEAK POWER SPECTRAL DENSITY MEASUREMENT

4.5.1 LIMITS OF PEAK POWER SPECTRAL DENSITY MEASUREMENT

FREQUENCY BAND	LIMIT
5.15 ~ 5.25GHz	4dBm

4.5.2 TEST INSTRUMENTS

DESCRIPTION & MANUFACTURER	MODEL NO.	SERIAL NO.	CALIBRATED UNTIL
R&S SPECTRUM ANALYZER	FSP40	100040	Jun. 28, 2008

NOTE: The calibration interval of the above test instruments is 12 months and the calibrations are traceable to NML/ROC and NIST/USA.

4.5.3 TEST PROCEDURES

- a. The transmitter output was connected to the spectrum analyzer.
- b. Set RBW = 1MHz, VBW = 3MHz. The PPSD is the highest level found across the emission in any 1MHz band.

4.5.4 DEVIATION FROM TEST STANDARD

No deviation

4.5.5 TEST SETUP

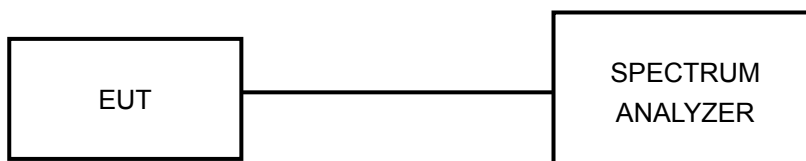

4.5.6 EUT OPERATING CONDITIONS

Same as 5.3.6

4.5.7 TEST RESULTS

802.11a OFDM MODULATION

MODULATION TYPE	AMIMON Proprietary	TRANSFER RATE	6.0Mbps
INPUT POWER (SYSTEM)	120Vac, 60Hz	ENVIRONMENTAL CONDITIONS	27 deg.C, 66 %RH, 991hPa
TESTED BY	Dean Wang		

CHAN.	CHAN. FREQ. (MHz)	RF POWER LEVEL IN 1MHz BW (dBm)				TOTAL POWER DENSITY (mW)	TOTAL POWER DENSITY (dBm)	MAXIMUM LIMIT (dBm)	PASS / FAIL
		CHAIN 0	CHAIN 1	CHAIN 2	CHAIN 3				
6	5180	-4.08	-5.77	-5.70	-7.10	1.120	0.49	4	PASS
40	5200	-3.61	-5.33	-5.40	-6.60	1.236	0.92	4	PASS
48	5240	-3.67	-4.87	-4.63	-6.15	1.342	1.28	4	PASS

FOR CHAIN 0: CH 36

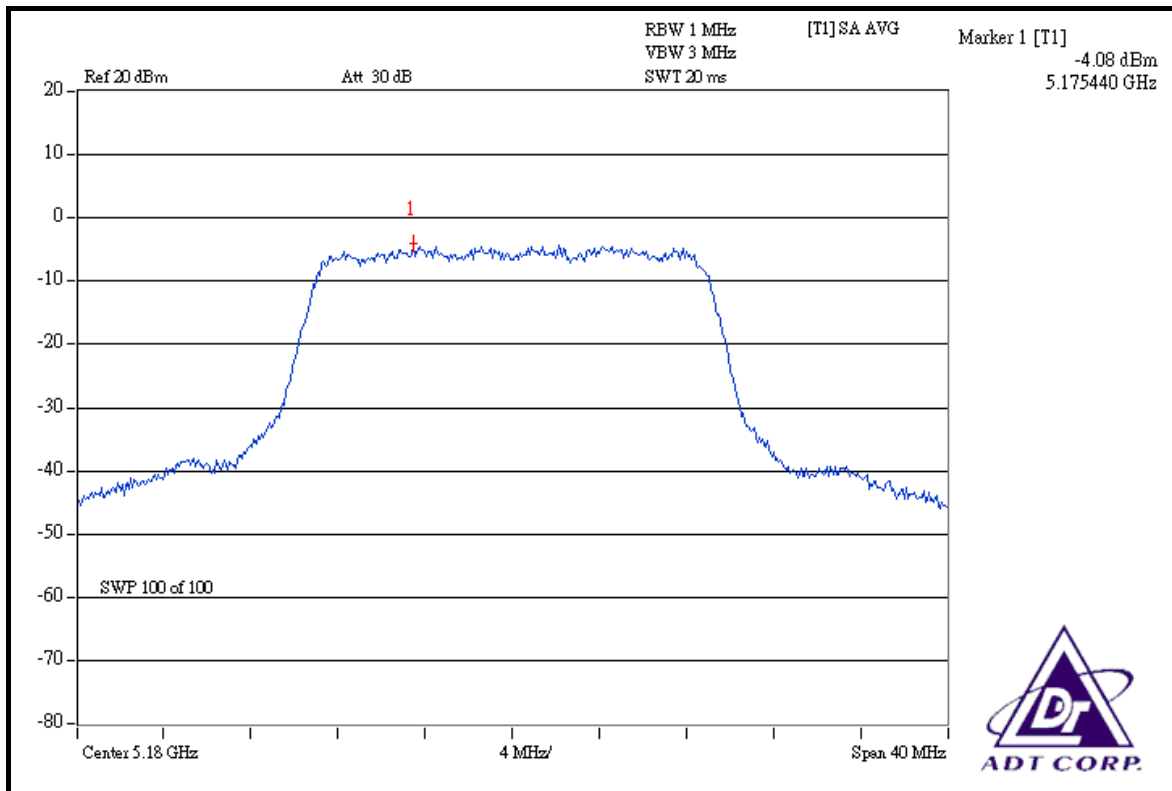



FOR CHAIN 0: CH 40

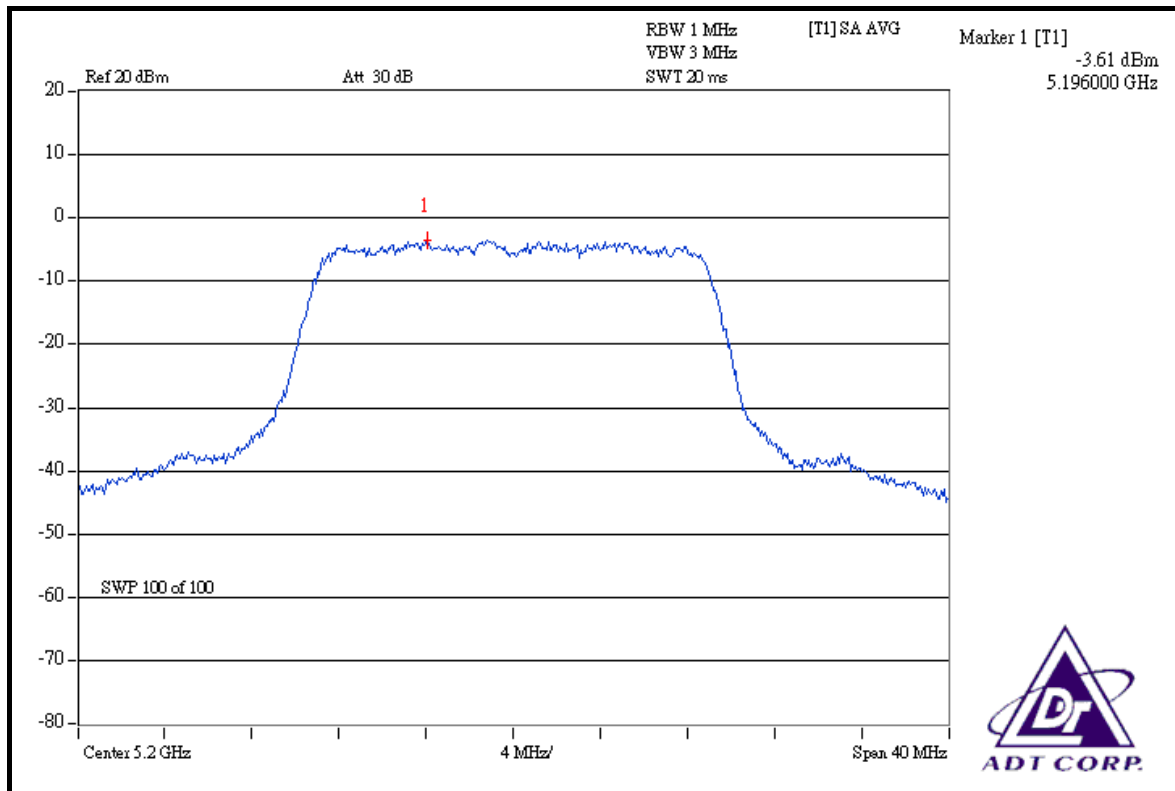

FOR CHAIN 0: CH 48

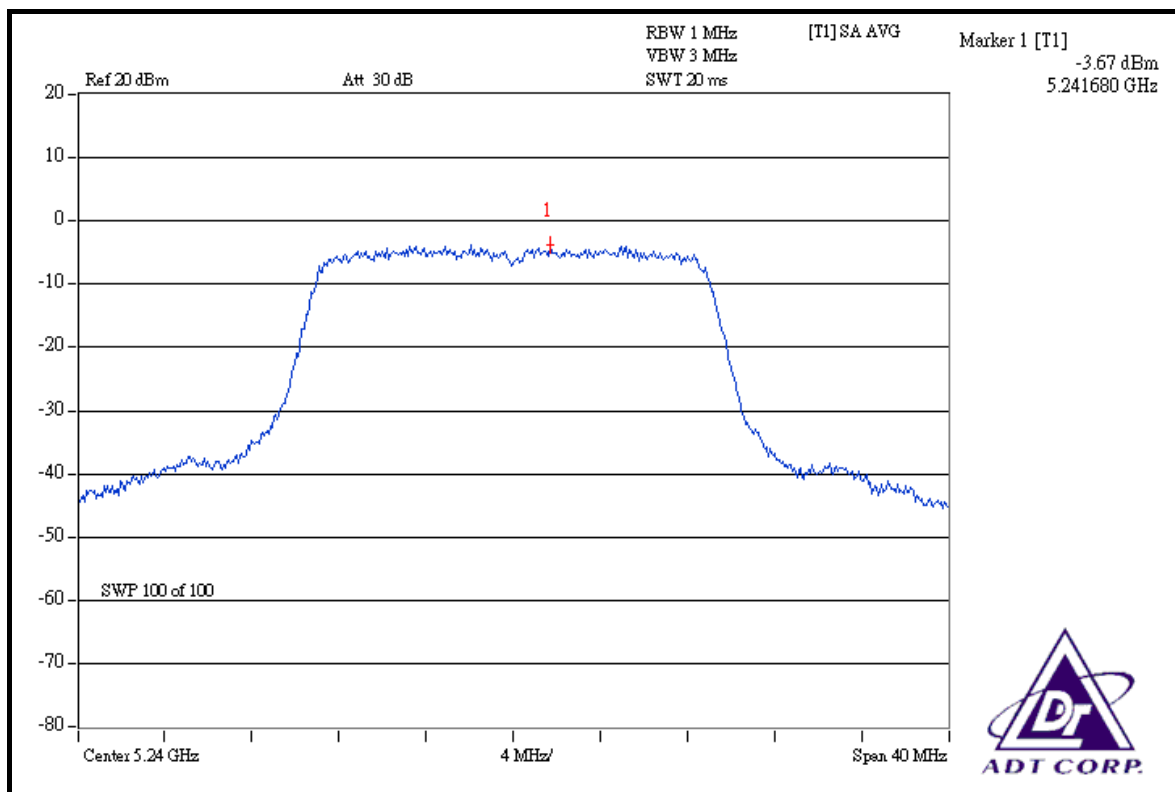



FOR CHAIN 1: CH 36

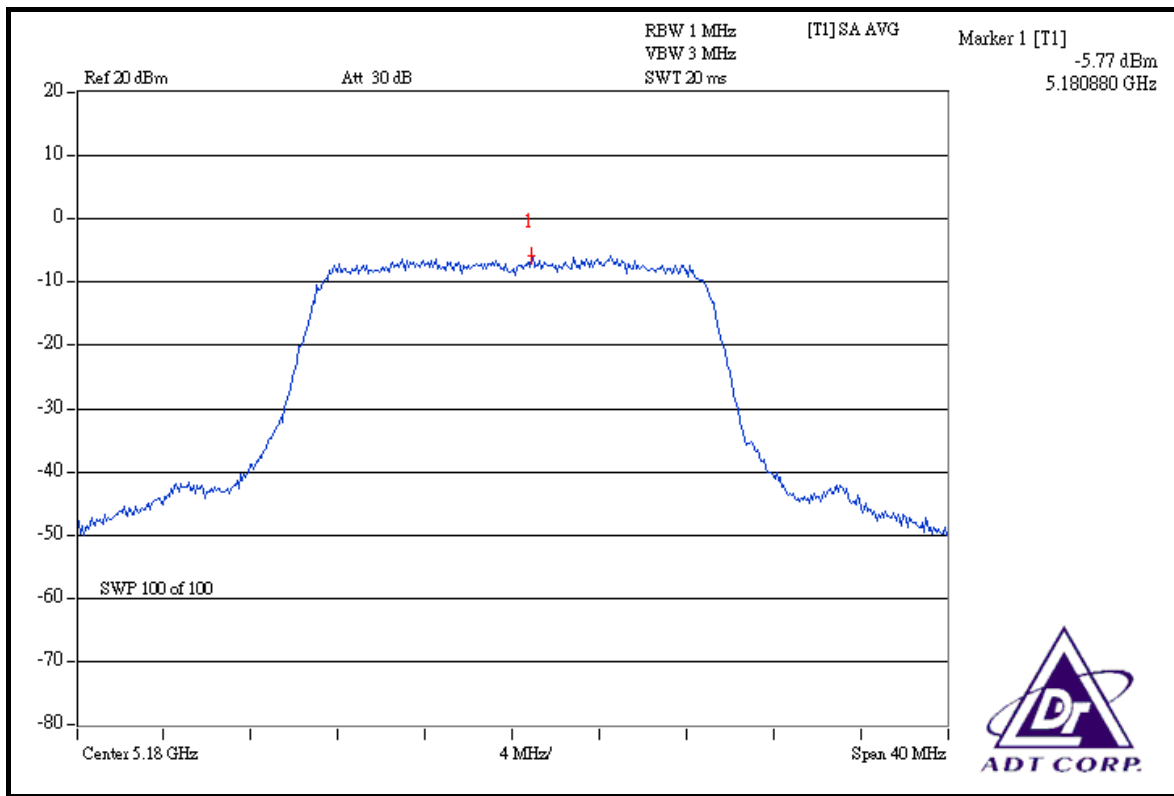

FOR CHAIN 1: CH 40

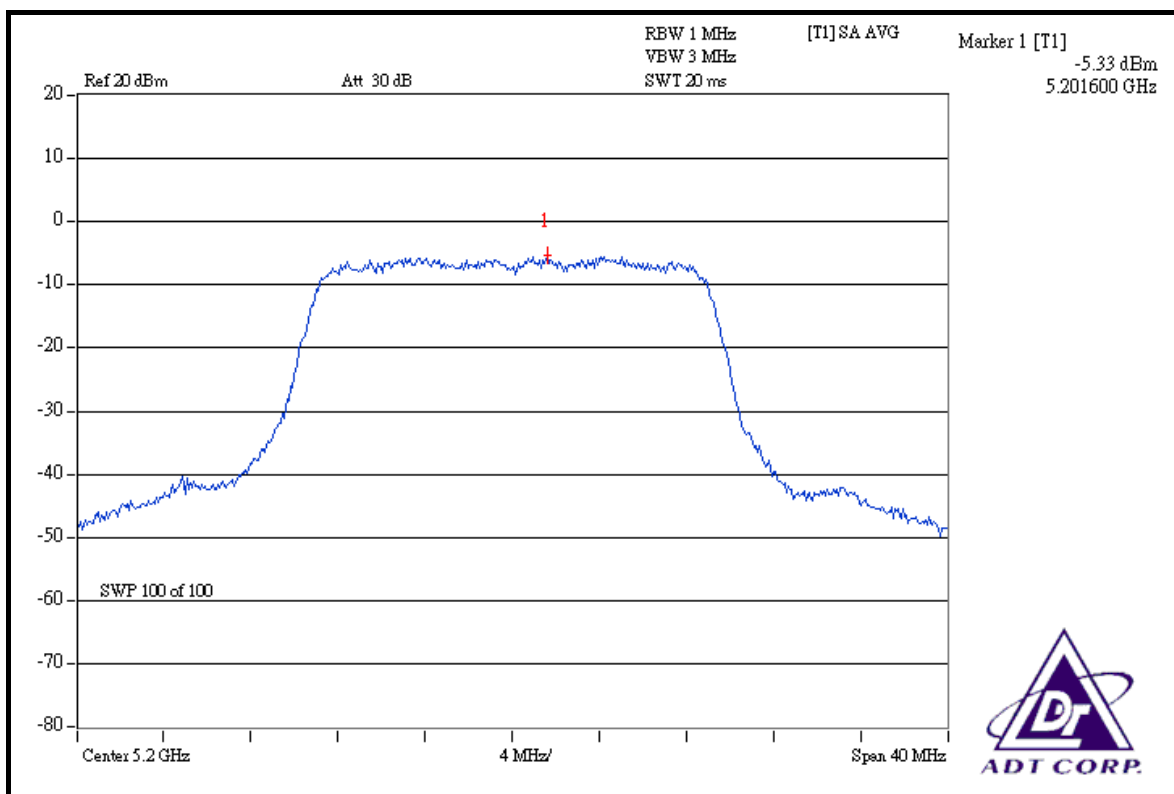



FOR CHAIN 1: CH 48

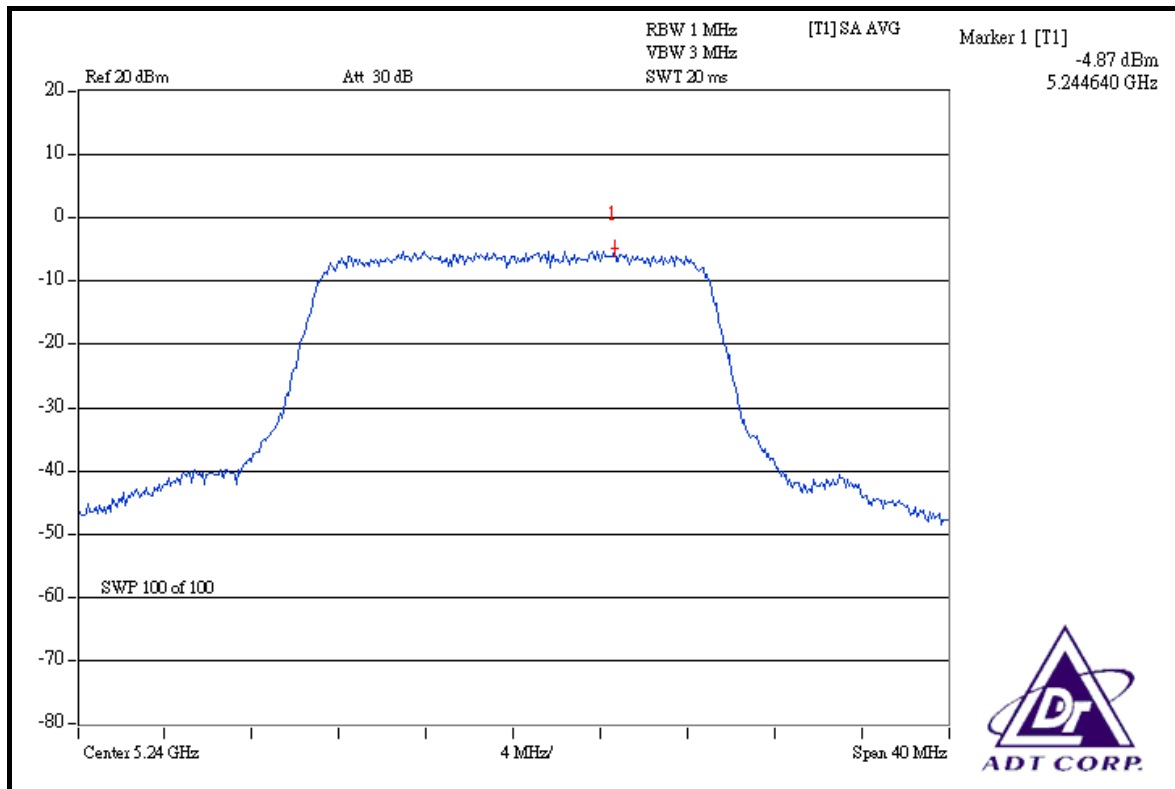

FOR CHAIN 2: CH 36

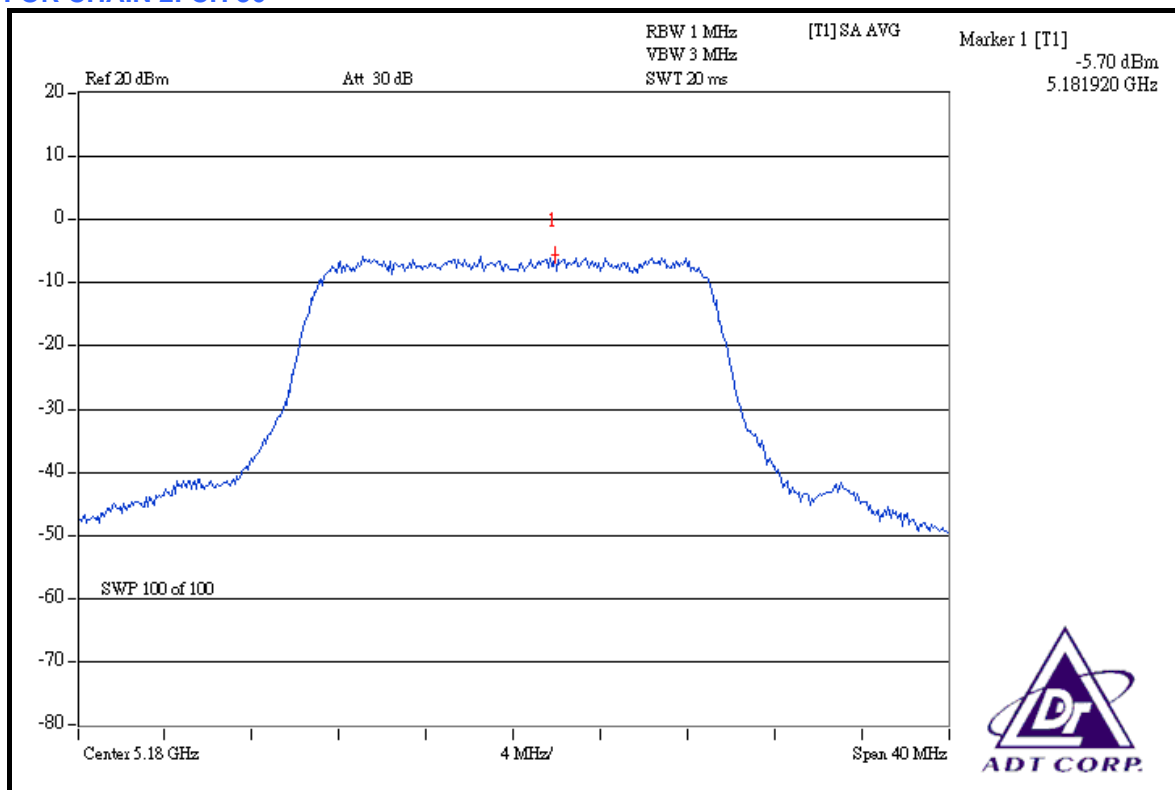



FOR CHAIN 2: CH 40

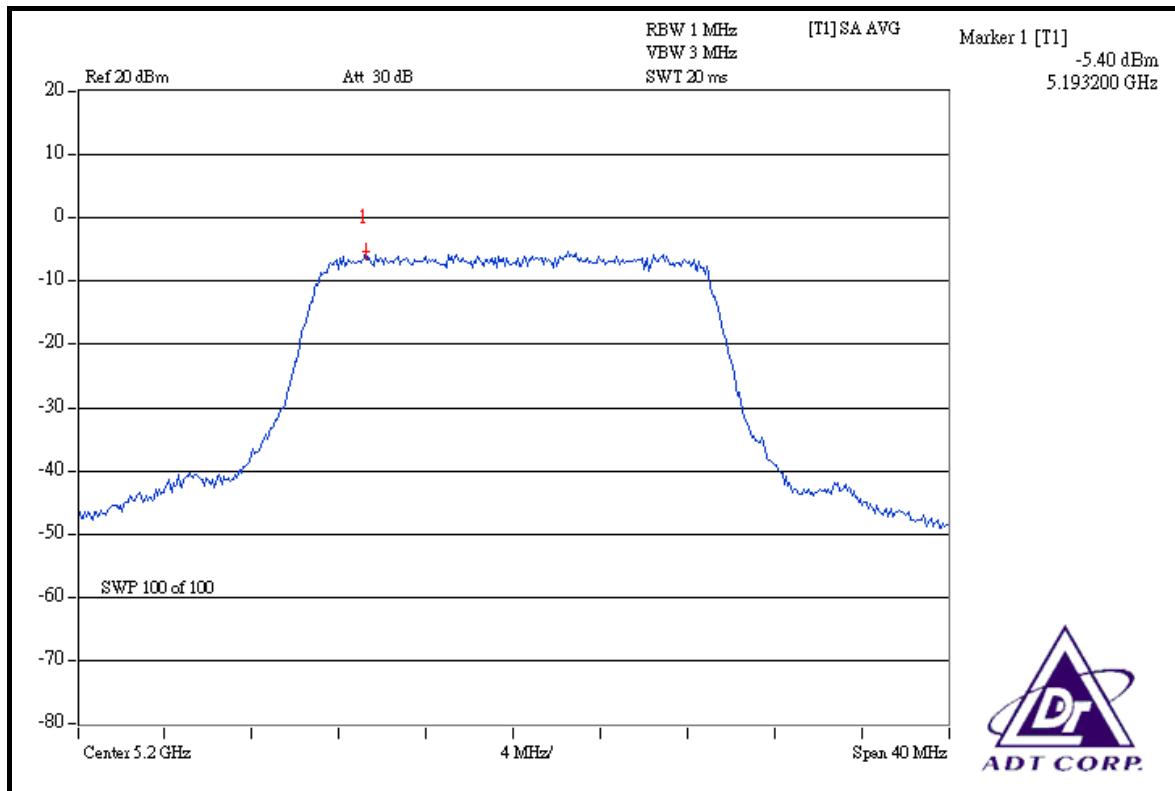

FOR CHAIN 2: CH 48

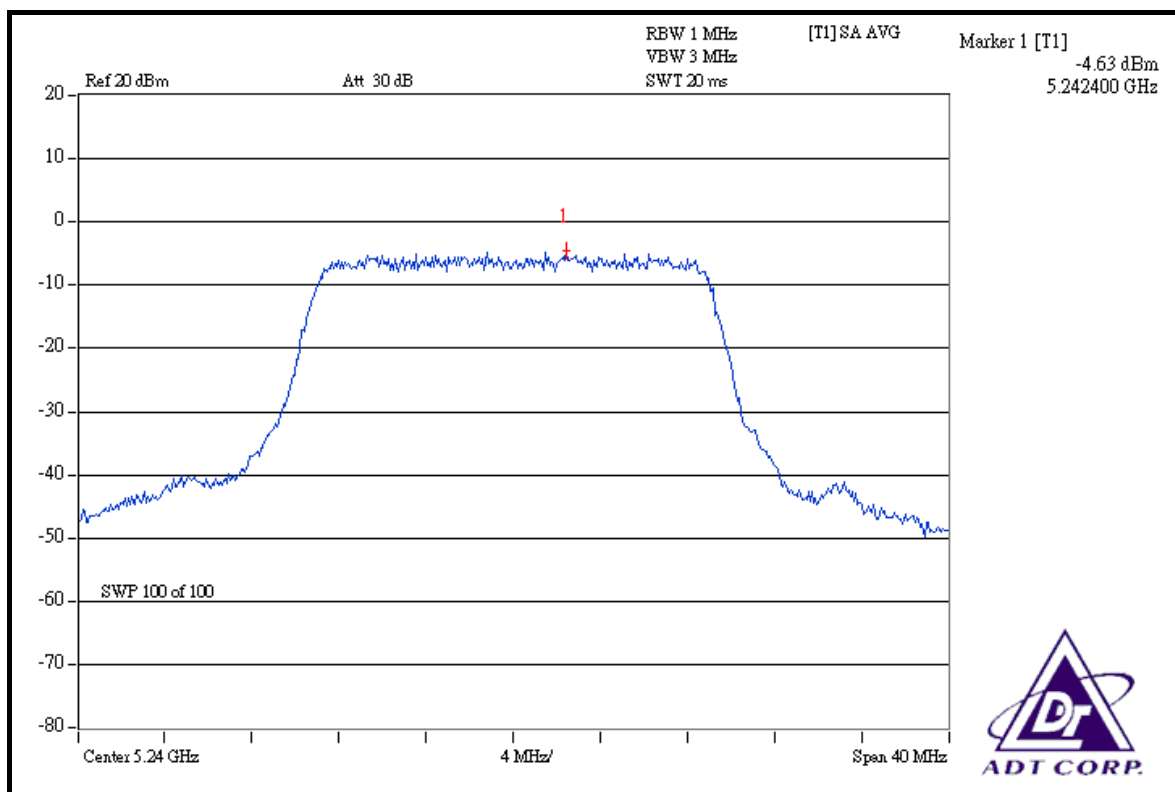



FOR CHAIN 3: CH 36

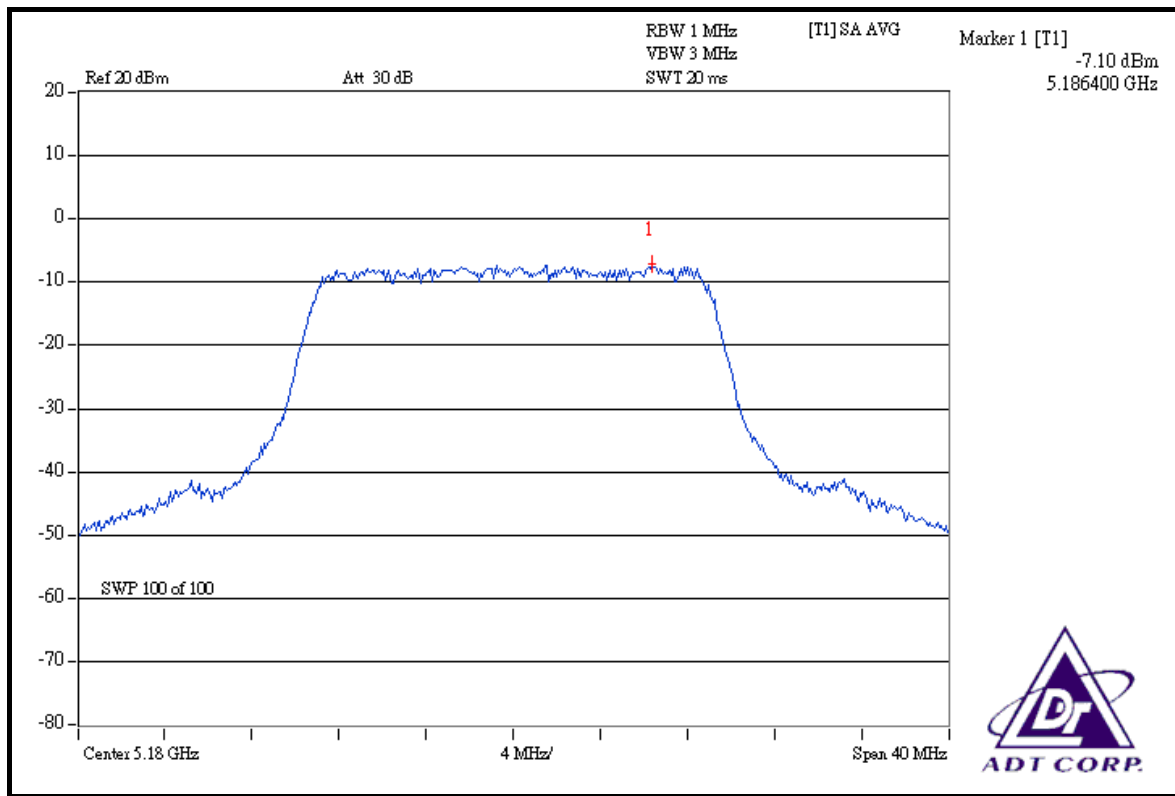

FOR CHAIN 3: CH 40

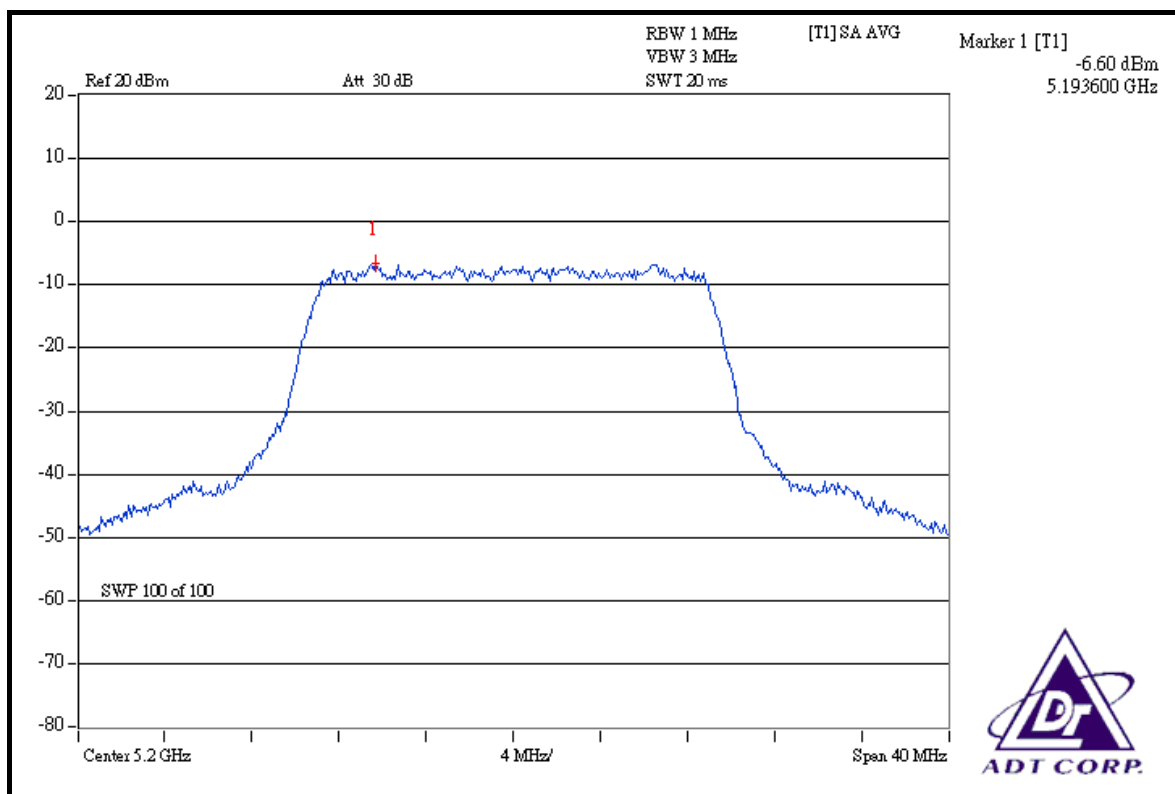



FOR CHAIN 3: CH 48

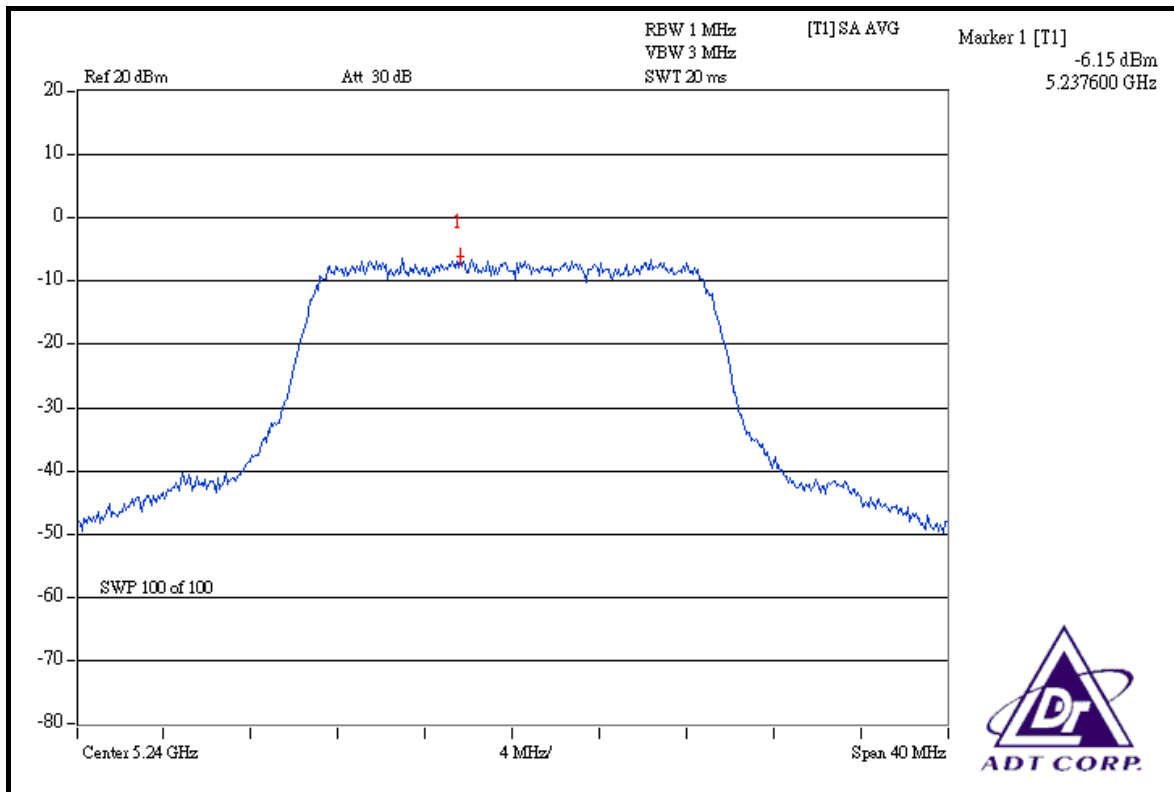

4.6 FREQUENCY STABILITY

4.6.1 LIMITS OF FREQUENCY STABILITY MEASUREMENT

The frequency tolerance of the carrier signal shall be maintained within +/- 0.02% of the operating frequency over a temperature variation of -30 degrees to 50 degrees C at normal supply voltage, and for a variation in the primary supply voltage from 85% to 115% of the rated supply voltage at a temperature of 20 degrees C.

4.6.2 TEST INSTRUMENTS

DESCRIPTION & MANUFACTURER	MODEL NO.	SERIAL NO.	CALIBRATED UNTIL
ANRITSU SPECTRUM ANALYZER	MS2667C	M10281	Nov. 21, 2008
WIT STANDARD TEMPERATURE AND HUMIDITY CHAMBER	TH-4S-C	W981030	Jun. 28, 2008

NOTE: The calibration interval of the above test instruments is 12 months and the calibrations are traceable to NML/ROC and NIST/USA.

4.6.3 TEST PROCEDURE

- a. The EUT was placed inside the environmental test chamber and powered by nominal DC voltage.
- b. Turn the EUT on and couple its output to a spectrum analyzer.
- c. Turn the EUT off and set the chamber to the highest temperature specified.
- d. Allow sufficient time (approximately 30 min) for the temperature of the chamber to stabilize, turn the EUT on and measure the operating frequency after 2, 5, and 10 minutes.
- e. Repeat step 2 and 3 with the temperature chamber set to the lowest temperature.
- f. The test chamber was allowed to stabilize at +20 degree C for a minimum of 30 minutes. The supply voltage was then adjusted on the EUT from 85% to 115% and the frequency record.

4.6.4 DEVIATION FROM TEST STANDARD

No deviation

4.6.5 TEST SETUP

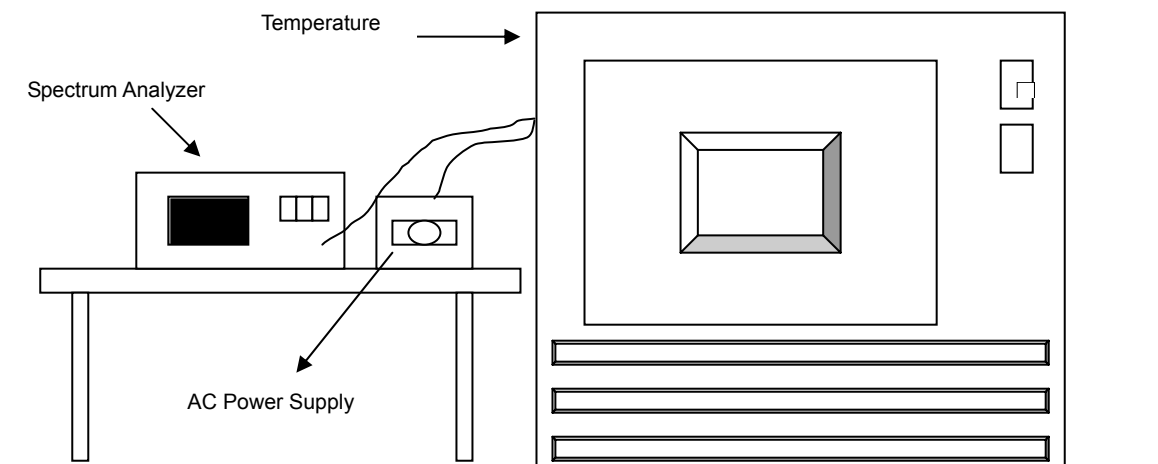

4.6.6 EUT OPERATING CONDITION

Same as Item 4.1.6



4.6.7 TEST RESULTS

OPERATING FREQUENCY: 5200MHz						LIMIT: ± 0.01%			
TEMP. (°C)	POWER SUPPLY (Vac)	0 MINUTE		2 MINUTE		5 MINUTE		10 MINUTE	
		(MHz)	(%)	(MHz)	(%)	(MHz)	(%)	(MHz)	(%)
50	126.5	5199.900629	-0.0019110	5199.932200	-0.0013038	5199.951763	-0.0009276	5199.94044	-0.0011454
	110.0	5199.898231	-0.0019571	5199.912640	-0.0016800	5199.932354	-0.0013009	5199.920023	-0.0015380
	93.5	5199.897922	-0.0019630	5199.917050	-0.0015952	5199.935704	-0.0012365	5199.925132	-0.0014398
40	126.5	5199.892634	-0.0020647	5199.908243	-0.0017646	5199.928779	-0.0013696	5199.919766	-0.0015430
	110.0	5199.895572	-0.0020082	5199.915224	-0.0016303	5199.933837	-0.0012724	5199.925068	-0.0014410
	93.5	5199.903642	-0.0018530	5199.925923	-0.0014246	5199.945091	-0.0010559	5199.934149	-0.0012664
30	126.5	5199.893526	-0.0020476	5199.910072	-0.0017294	5199.929266	-0.0013603	5199.920998	-0.0015193
	110.0	5199.899234	-0.0019378	5199.916942	-0.0015973	5199.936424	-0.0012226	5199.931826	-0.0013110
	93.5	5199.916493	-0.0016059	5199.935144	-0.0012472	5199.957269	-0.0008217	5199.946464	-0.0010295
20	126.5	5199.899065	-0.0019411	5199.917889	-0.0015791	5199.936871	-0.0012140	5199.924429	-0.0014533
	110.0	5199.903376	-0.0018582	5199.914662	-0.0016411	5199.937623	-0.0011996	5199.924875	-0.0014447
	93.5	5199.924723	-0.0014476	5199.941269	-0.0011294	5199.962719	-0.0007169	5199.946151	-0.0010356
10	126.5	5199.906726	-0.0017937	5199.922200	-0.0014962	5199.945415	-0.0010497	5199.932814	-0.0012920
	110.0	5199.915740	-0.0016204	5199.931931	-0.0013090	5199.951833	-0.0009263	5199.943612	-0.0010844
	93.5	5199.935030	-0.0012494	5199.948540	-0.0009896	5199.969253	-0.0005913	5199.956504	-0.0008365
0	126.5	5199.911148	-0.0017087	5199.927462	-0.0013950	5199.947757	-0.0010047	5199.941594	-0.0011232
	110.0	5199.918333	-0.0015705	5199.943085	-0.0010945	5199.960569	-0.0007583	5199.951402	-0.0009346
	93.5	5199.937272	-0.0012063	5199.952688	-0.0009098	5199.973281	-0.0005138	5199.965925	-0.0006553
-10	126.5	5199.920666	-0.0015257	5199.939781	-0.0011581	5199.960379	-0.0007619	5199.953913	-0.0008863
	110.0	5199.931671	-0.0013140	5199.948370	-0.0009929	5199.967912	-0.0006171	5199.956786	-0.0008310
	93.5	5199.941959	-0.0011162	5199.960252	-0.0007644	5199.981808	-0.0003498	5199.972621	-0.0005265
-20	126.5	5199.928749	-0.0013702	5199.947187	-0.0010156	5199.965193	-0.0006694	5199.953905	-0.0008864
	110.0	5199.933880	-0.0012715	5199.949442	-0.0009723	5199.971461	-0.0005488	5199.960619	-0.0007573
	93.5	5199.946790	-0.0010233	5199.965009	-0.0006729	5199.984012	-0.0003075	5199.972222	-0.0005342
-30	126.5	5199.928763	-0.0013699	5199.950792	-0.0009463	5199.969551	-0.0005856	5199.963985	-0.0006926
	110.0	5199.947792	-0.0010040	5199.965869	-0.0006564	5199.987186	-0.0002464	5199.969789	-0.0005810
	93.5	5199.948868	-0.0009833	5199.970143	-0.0005742	5199.990318	-0.0001862	5199.973200	-0.0005154



4.7 BAND EDGES MEASUREMENT

4.7.1 TEST INSTRUMENTS

DESCRIPTION & MANUFACTURER	MODEL NO.	SERIAL NO.	CALIBRATED UNTIL
Test Receiver ROHDE & SCHWARZ	ESI7	838496/016	Dec. 25, 2008
Spectrum Analyzer ROHDE & SCHWARZ	FSP40	100039	Dec. 02, 2008
BILOG Antenna SCHWARZBECK	VULB9168	9168-155	Jan. 03, 2009
HORN Antenna SCHWARZBECK	BBHA 9120D	9120D-405	Dec. 17, 2008
HORN Antenna SCHWARZBECK	BBHA 9170	BBHA9170242	Jan. 06, 2009
Preamplifier Agilent	8449B	3008A01910	Sep. 19, 2008
Preamplifier Agilent	8447D	2944A10634	Dec. 12, 2008
RF signal cable HUBER+SUHNNER	SUCOFLEX 104	274397/4	Nov. 07, 2008
RF signal cable HUBER+SUHNNER	SUCOFLEX 104	283401/4	Nov. 07, 2008
Software ADT.	ADT_Radiated_V7.6	NA	NA
Antenna Tower inn-co GmbH	MA 4000	010303	NA
Turn Table ADT.	TT100.	TT93021704	NA
Turn Table Controller ADT.	SC100.	SC93021704	NA

NOTE: The calibration interval of the above test instruments is 12 months and the calibrations are traceable to NML/ROC and NIST/USA.

4.7.2 TEST PROCEDURE

FOR RADIATED MEASUREMENT:

- a. The EUT was placed on the top of a rotating table 0.8 meters above the ground at a 3 meter semi-anechoic chamber. The table was rotated 360 degrees to determine the position of the highest radiation.
- b. The EUT was set 3 meters away from the interference-receiving antenna, which was mounted on the top of a variable-height antenna tower.
- c. The antenna is a broadband antenna, and its height is varied from one meter to four meters above the ground to determine the maximum value of the field strength. Both horizontal and vertical polarizations of the antenna are set to make the measurement.
- d. For each suspected emission, the EUT was arranged to its worst case and then the antenna was tuned to heights from 1 meter to 4 meters and the rotatable table was turned from 0 degrees to 360 degrees to find the maximum reading.
- e. Set both RBW and VBW of spectrum analyzer to 1MHz and 3MHz with suitable frequency span including 100MHz bandwidth from band edge. The band edges was measured and recorded.

NOTE: The resolution bandwidth of test receiver/spectrum analyzer is 1MHz and the video bandwidth is 10Hz for Average detection (AV) at frequency above 1GHz

4.7.3 EUT OPERATING CONDITION

The software provided by client to enable the EUT under transmission condition continuously at specific channel frequencies individually.

4.7.4 TEST RESULTS

For signals in the restricted bands above and below the 5.15 to 5.25GHz allocated band a measurement was made of the amplitude of the spurious emissions with respect to the intentional signals. The relative amplitude, in dBc, was applied to the average and peak field strength of the intentional signal made on the OATS to calculate the field strength of the unintentional signals.

The spectrum plots (Peak RBW = 1MHz, VBW = 3MHz) are attached on the following pages.

802.11a OFDM MODULATION

Channel 36 (5180MHz)

The band edge emission plot on the next page shows 46.42dBc between carrier maximum power and local maximum emission in restrict band. The emission of carrier strength list in the test result of channel 36 is 112.99dBuV/m (Peak), so the maximum field strength in restrict band is $112.99 - 46.42 = 66.57$ dBuV/m which is under 74dBuV/m limit.

The band edge emission plot on the next page shows 51.18dBc between carrier maximum power and local maximum emission in restrict band. The emission of carrier strength list in the test result of channel 36 is 99.63dBuV/m (Average), so the maximum field strength in restrict band is $99.63 - 51.18 = 48.45$ dBuV/m which is under 54dBuV/m limit.

Channel 48 (5240MHz)

The band edge emission plot on the next second page shows 54.56dBc between carrier maximum power and local maximum emission in restrict band. The emission of carrier strength list in the test result of channel 48 is 115.64dBuV/m (Peak), so the maximum field strength in restrict band is $115.64 - 54.56 = 61.08$ dBuV/m which is under 74dBuV/m limit.

The band edge emission plot on the next third page shows 53.50dBc between carrier maximum power and local maximum emission in restrict band. The emission of carrier strength list in the test result of channel 48 is 102.04dBuV/m (Average), so the maximum field strength in restrict band is $102.04 - 53.50 = 48.54$ dBuV/m which is under 54dBuV/m limit.

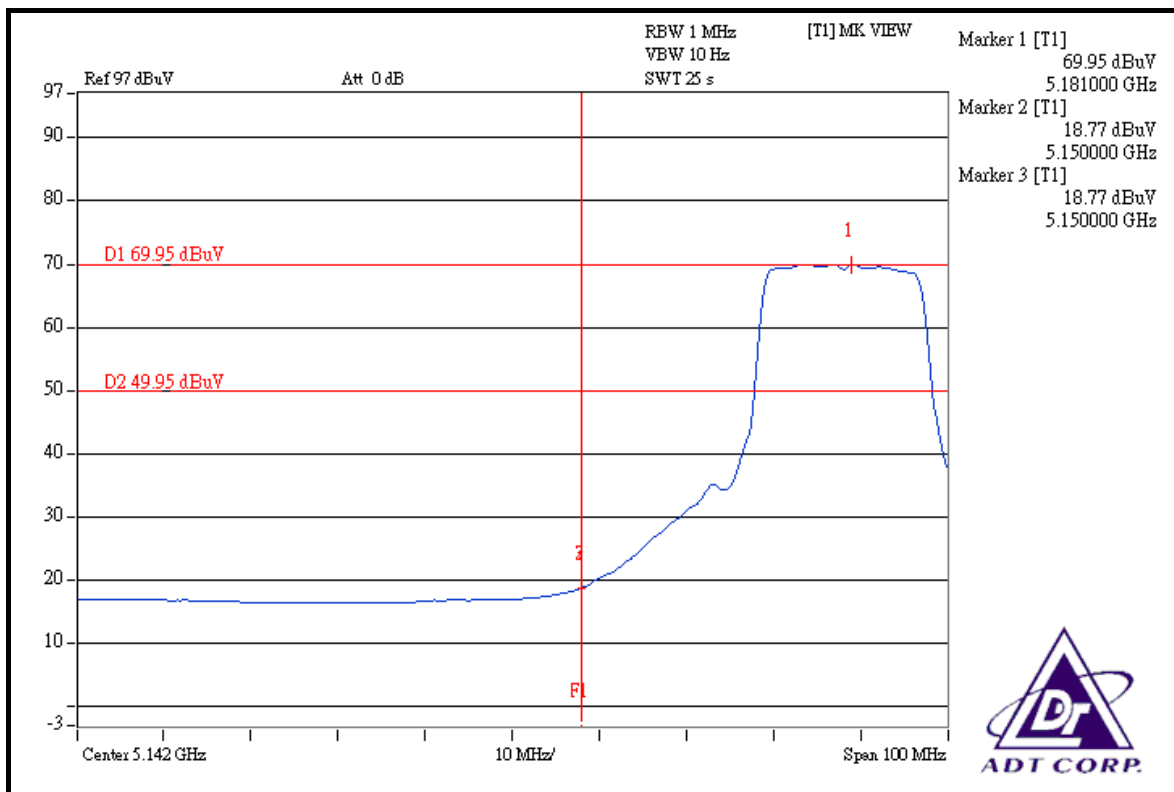
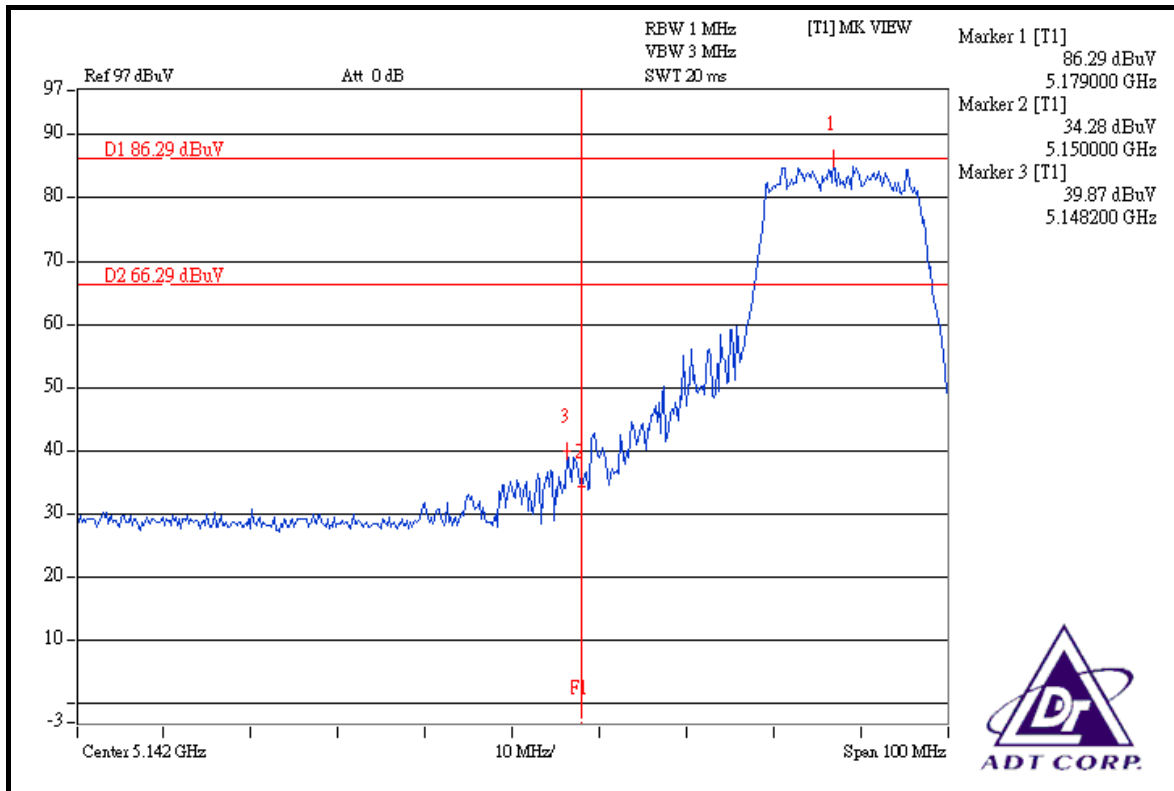

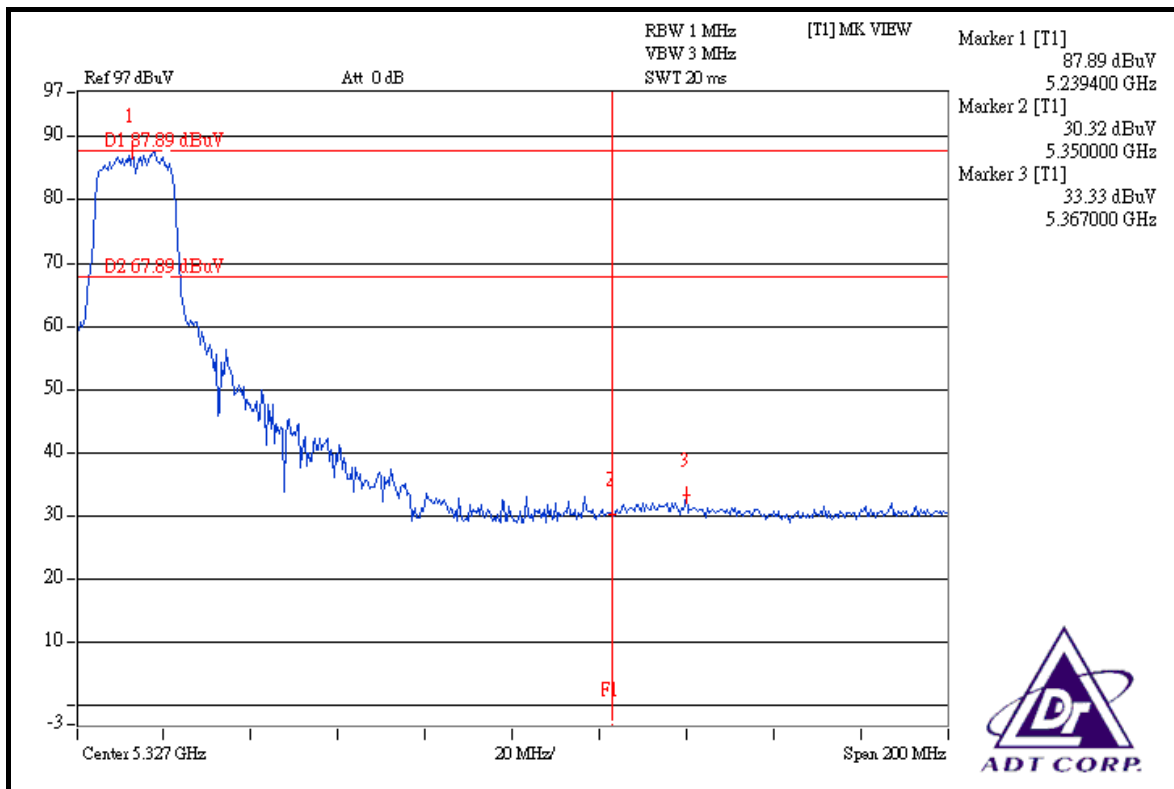
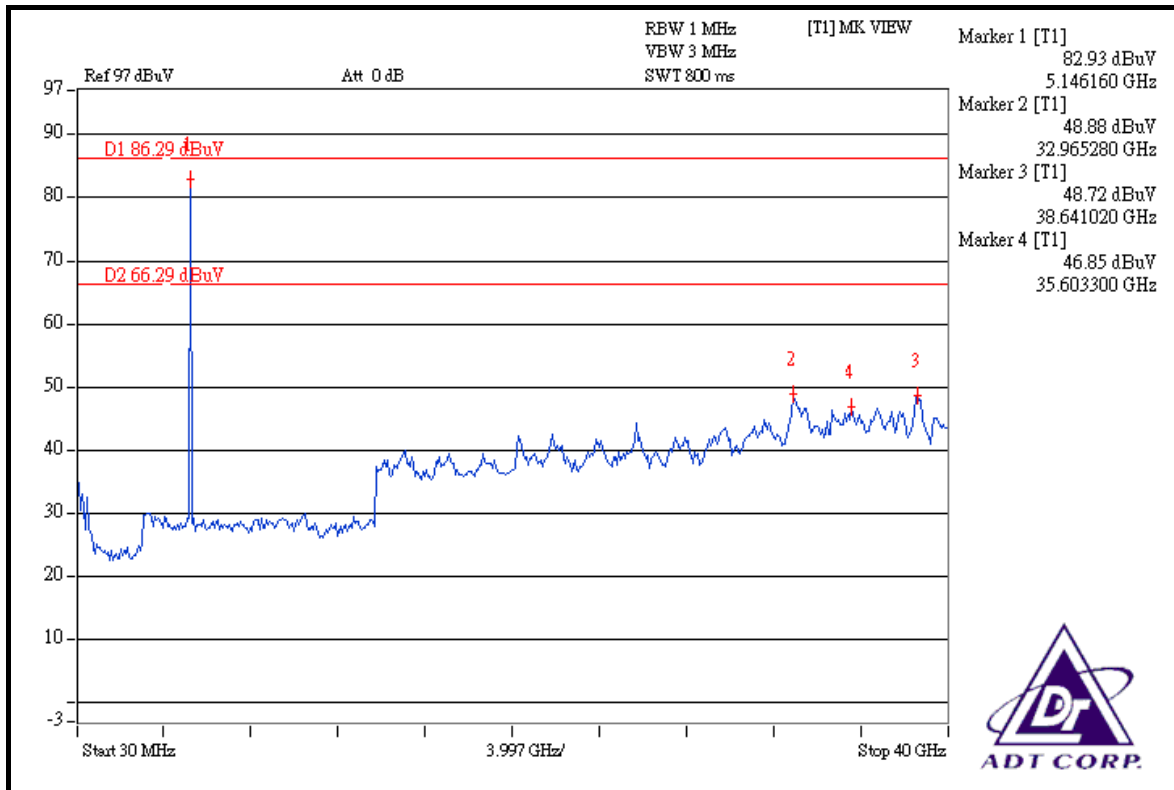

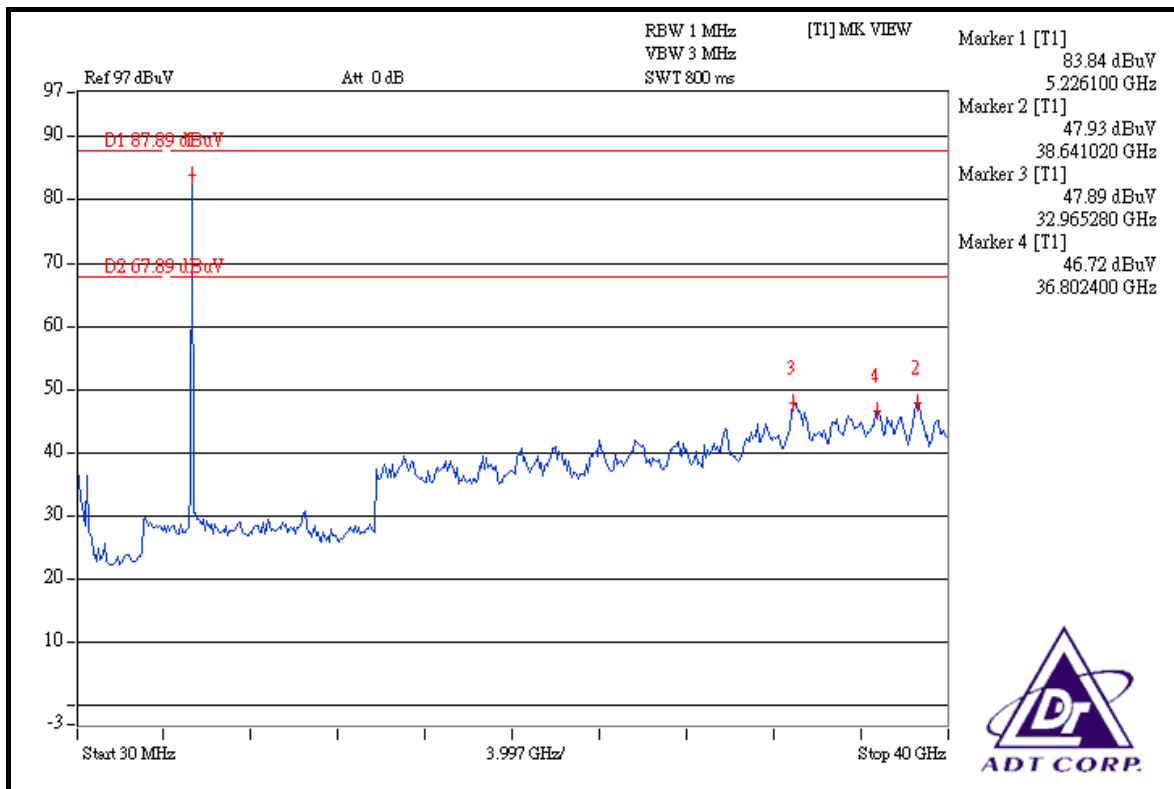
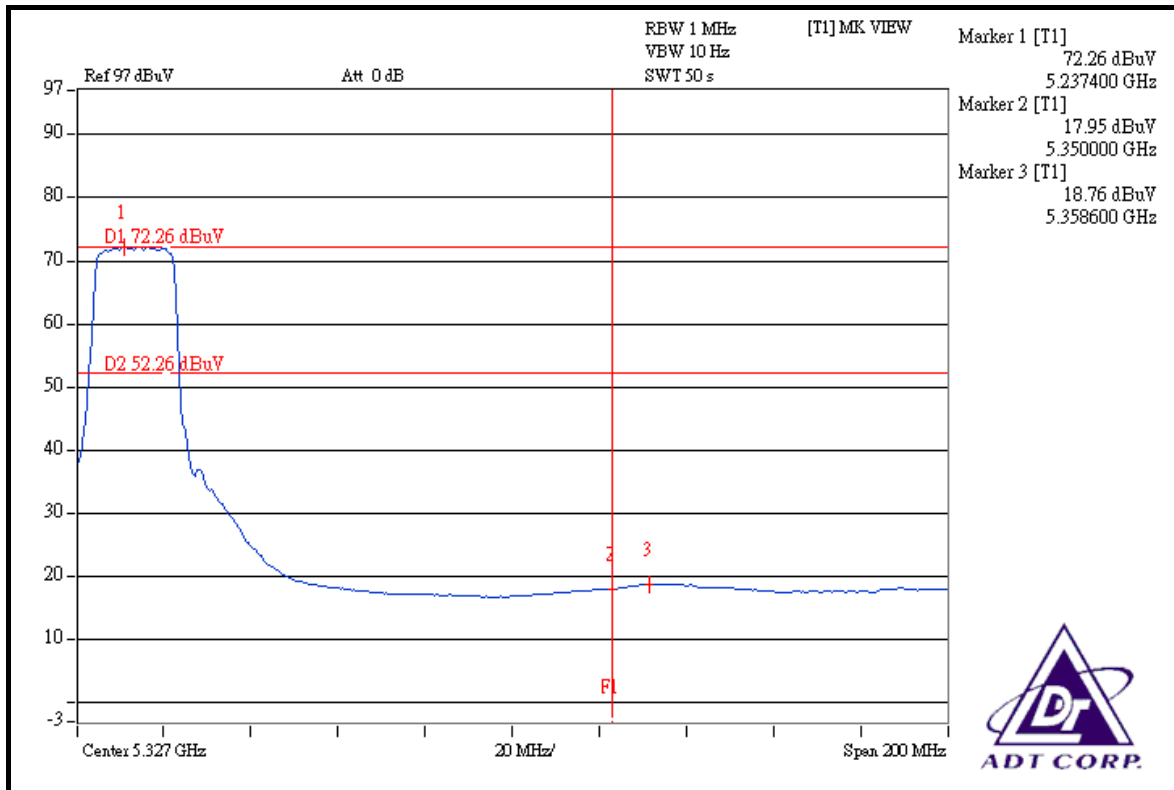



4.8 ANTENNA REQUIREMENT

4.8.1 STANDARD APPLICABLE

For intentional device, according to FCC 47 CFR Section 15.203, an intentional radiator shall be designed to ensure that no antenna other than that furnished by the responsible party shall be used with the device.

And according to FCC 47 CFR Section 15.407(a), if transmitting antennas of directional gain greater than 6dBi are used, the power shall be reduced by the amount in dB that the directional gain of the antenna exceeds 6dBi.

4.8.2 ANTENNA CONNECTED CONSTRUCTION

The antenna used in this product is Printed antenna without connector. The maximum Gain of the antenna is 3.12dBi.



5. PHOTOGRAPHS OF THE TEST CONFIGURATION

Please refer to the attached file (Test Setup Photo).



6. INFORMATION ON THE TESTING LABORATORIES

We, ADT Corp., were founded in 1988 to provide our best service in EMC, Radio, Telecom and Safety consultation. Our laboratories are accredited and approved by the following approval agencies according to ISO/IEC 17025.

USA	FCC, UL, A2LA
Germany	TUV Rheinland
Japan	VCCI
Norway	NEMKO
Canada	INDUSTRY CANADA , CSA
R.O.C.	TAF, BSMI, NCC
Netherlands	Telefication
Singapore	GOST-ASIA(MOU)
Russia	CERTIS(MOU)

Copies of accreditation certificates of our laboratories obtained from approval agencies can be downloaded from our web site:
www.adt.com.tw/index.5/phtml. If you have any comments, please feel free to contact us at the following:

Linko EMC/RF Lab:
Tel: 886-2-26052180
Fax: 886-2-26051924

Hsin Chu EMC/RF Lab:
Tel: 886-3-5935343
Fax: 886-3-5935342

Hwa Ya EMC/RF/Safety Telecom Lab:
Tel: 886-3-3183232
Fax: 886-3-3185050

Web Site: www.adt.com.tw

The address and road map of all our labs can be found in our web site also.

7. APPENDIX A - MODIFICATIONS RECORDERS FOR ENGINEERING CHANGES TO THE EUT BY THE LAB

No any modifications are made to the EUT by the lab during the test.