



FCC TEST REPORT (15.407)

REPORT NO.: RF990714C11A

MODEL NO.: HB557 (refer to 3.1 for more detail)

FCC ID: T5U-HB557

RECEIVED: Aug. 06, 2010

TESTED: Aug. 06 ~ Aug. 26, 2010

ISSUED: Sep. 24, 2010

APPLICANT: Quanta Microsystems, Inc.

ADDRESS: 188 Wenhwa 2nd Rd., Kueishan Hsiang Taoyuan
Shien 333, Taiwan, R.O.C.

ISSUED BY: Bureau Veritas Consumer Products Services
(H.K.) Ltd., Taoyuan Branch

LAB ADDRESS: No. 47, 14th Ling, Chia Pau Tsuen, Lin Kou
Hsiang, Taipei Hsien 244, Taiwan, R.O.C.

TEST LOCATION: No. 19, Hwa Ya 2nd Rd, Wen Hwa Tsuen, Kwei
Shan Hsiang, Taoyuan Hsien 333, Taiwan,
R.O.C.

This test report consists of 53 pages in total. It may be duplicated completely for legal use with the approval of the applicant. It should not be reproduced except in full, without the written approval of our laboratory. The client should not use it to claim product certification, approval or endorsement by TAF or any government agency. The test results in the report only apply to the tested sample.



TABLE OF CONTENTS

1.	CERTIFICATION.....	4
2.	SUMMARY OF TEST RESULTS	5
2.1	MEASUREMENT UNCERTAINTY.....	5
3.	GENERAL INFORMATION.....	6
3.1	GENERAL DESCRIPTION OF EUT	6
3.2	DESCRIPTION OF TEST MODES.....	7
3.2.1	CONFIGURATION OF SYSTEM UNDER TEST	7
3.2.2	TEST MODE APPLICABILITY AND TESTED CHANNEL DETAIL	8
3.3	GENERAL DESCRIPTION OF APPLIED STANDARDS	10
3.4	DESCRIPTION OF SUPPORT UNITS	10
4.	TEST TYPES AND RESULTS	11
4.1	RADIATED EMISSION MEASUREMENT	11
4.1.1	LIMITS OF RADIATED EMISSION MEASUREMENT.....	11
4.1.2	LIMITS OF UNWANTED EMISSION OUT OF THE RESTRICTED BANDS.....	11
4.1.3	TEST INSTRUMENTS.....	12
4.1.4	TEST PROCEDURES	13
4.1.5	DEVIATION FROM TEST STANDARD.....	13
4.1.6	TEST SETUP.....	14
4.1.7	EUT OPERATING CONDITION.....	14
4.1.8	TEST RESULTS	15
4.2	CONDUCTED EMISSION MEASUREMENT	22
4.2.1	LIMITS OF CONDUCTED EMISSION MEASUREMENT.....	22
4.2.2	TEST INSTRUMENTS.....	22
4.2.3	TEST PROCEDURES	23
4.2.4	DEVIATION FROM TEST STANDARD.....	23
4.2.5	TEST SETUP.....	24
4.2.6	EUT OPERATING CONDITIONS	24
4.2.7	TEST RESULTS	25
4.3	MAXIMUM CONDUCTED OUTPUT POWER MEASUREMENT	29
4.3.1	LIMITS OF MAXIMUM CONDUCTED OUTPUT POWER MEASUREMENT.....	29
4.3.2	TEST INSTRUMENTS.....	29
4.3.3	TEST PROCEDURE.....	30
4.3.4	DEVIATION FROM TEST STANDARD.....	30
4.3.5	TEST SETUP.....	30
4.3.6	EUT OPERATING CONDITIONS	30
4.3.7	TEST RESULTS	31
4.4	PEAK POWER EXCURSION MEASUREMENT	32
4.4.1	LIMITS OF PEAK POWER EXCURSION MEASUREMENT.....	32
4.4.2	TEST INSTRUMENTS.....	32
4.4.3	TEST PROCEDURE.....	32
4.4.4	DEVIATION FROM TEST STANDARD.....	33
4.4.5	TEST SETUP.....	33
4.4.6	EUT OPERATING CONDITIONS	33
4.4.7	TEST RESULTS	34
4.5	PEAK POWER SPECTRAL DENSITY MEASUREMENT	36
4.5.1	LIMITS OF PEAK POWER SPECTRAL DENSITY MEASUREMENT.....	36



A D T

4.5.2	TEST INSTRUMENTS.....	36
4.5.3	TEST PROCEDURES	36
4.5.4	DEVIATION FROM TEST STANDARD.....	37
4.5.5	TEST SETUP	37
4.5.6	EUT OPERATING CONDITIONS	37
4.5.7	TEST RESULTS	38
4.6	FREQUENCY STABILITY.....	39
4.6.1	LIMITS OF FREQUENCY STABILITY MEASUREMENT	39
4.6.2	TEST INSTRUMENTS.....	39
4.6.3	TEST PROCEDURE.....	39
4.6.4	DEVIATION FROM TEST STANDARD.....	40
4.6.5	TEST SETUP.....	40
4.6.6	EUT OPERATING CONDITION.....	40
4.6.7	TEST RESULTS	41
4.7	BAND EDGES MEASUREMENT	42
4.7.1	TEST INSTRUMENTS.....	42
4.7.2	TEST PROCEDURE.....	42
4.7.3	EUT OPERATING CONDITION.....	42
4.7.4	TEST RESULTS	43
5.	PHOTOGRAPHS OF THE TEST CONFIGURATION	51
6.	INFORMATION ON THE TESTING LABORATORIES	52
7.	APPENDIX A - MODIFICATIONS RECORDERS FOR ENGINEERING CHANGES TO THE EUT BY THE LAB.....	53



1. CERTIFICATION

PRODUCT: Wireless HDMI Receiver (refer to item 3.1 for more detail)

MODEL: HB557 (refer to item 3.1 for more detail)

BRAND: QMI (refer to item 3.1 for more detail)

APPLICANT: Quanta Microsystems, Inc.

TEST SAMPLE: ENGINEERING SAMPLE

TESTED: Aug. 06 ~ Aug. 26, 2010

STANDARDS: FCC Part 15, Subpart E (Section 15.407)

ANSI C63.4-2003

The above equipment (Model: HB557) has been tested by **Bureau Veritas Consumer Products Services (H.K.) Ltd., Taoyuan Branch**, and found compliance with the requirement of the above standards. The test record, data evaluation & Equipment Under Test (EUT) configurations represented herein are true and accurate accounts of the measurements of the sample's EMC characteristics under the conditions specified in this report.

PREPARED BY : Andrea Hsia , **DATE:** Sep. 24, 2010
Andrea Hsia / Specialist

TECHNICAL ACCEPTANCE : Long Chen , **DATE:** Sep. 24, 2010
Responsible for RF Long Chen / Senior Engineer

APPROVED BY : Gary Chang , **DATE:** Sep. 24, 2010
Gary Chang / Assistant Manager

2. SUMMARY OF TEST RESULTS

The EUT has been tested according to the following specifications:

APPLIED STANDARD: FCC PART 15, SUBPART E (SECTION 15.407)			
STANDARD SECTION	TEST TYPE AND LIMIT	RESULT	REMARK
15.407(b)(5)	AC Power Conducted Emission	PASS	Meet the requirement of limit. Minimum passing margin is -16.29dB at 0.361MHz.
15.407(b/1/2/3)(b)(5)	Electric Field Strength Spurious Emissions, 30MHz ~ 40000MHz	PASS	Meet the requirement of limit. Minimum passing margin is -1.0dB at 5470.00MHz.
15.407(a/1/2/3)	Peak Transmit Power	PASS	Meet the requirement of limit.
15.407(a)(6)	Peak Power Excursion	PASS	Meet the requirement of limit.
15.407(a/1/2/3)	Peak Power Spectral Density	PASS	Meet the requirement of limit.
15.407(g)	Frequency Stability	PASS	Meet the requirement of limit.
15.203	Antenna Requirement	PASS	No antenna connector is used.

2.1 MEASUREMENT UNCERTAINTY

Where relevant, the following measurement uncertainty levels have been estimated for tests performed on the EUT as specified in CISPR 16-4-2:

MEASUREMENT	FREQUENCY	UNCERTAINTY
Conducted emissions	9kHz~30MHz	2.44 dB
Radiated emissions	30MHz ~ 200MHz	2.93 dB
	200MHz ~1000MHz	2.95 dB
	1GHz ~ 18GHz	2.26 dB
	18GHz ~ 40GHz	1.94 dB

This uncertainty represents an expanded uncertainty expressed at approximately the 95% confidence level using a coverage factor of $k = 2$.



3. GENERAL INFORMATION

3.1 GENERAL DESCRIPTION OF EUT

EUT	Wireless HDMI Receiver (refer to note as below)
MODEL NO.	HB557 (refer to note as below)
FCC ID	T5U-HB557
POWER SUPPLY	5Vdc
MODULATION TYPE	OOK
MODULATION TECHNOLOGY	OFDM
TRANSFER RATE	60 Kbps
OPERATING FREQUENCY	5270 ~ 5310MHz, 5510 ~ 5670MHz
NUMBER OF CHANNEL	5270 ~ 5310MHz: 2 5510 ~ 5670MHz: 3
OUTPUT POWER	20.9mW for 5270 ~ 5310MHz 20.9mW for 5510 ~ 5670MHz
ANTENNA TYPE	Printed antenna with 3.4dBi gain for 5310MHz Printed antenna with 3.5dBi gain for 5550MHz
ANTENNA CONNECTOR	NA
I/O PORTS	HDMI, USB port
DATA CABLE	HDMI cable 1m, HDMI cable 0.5m, USB splitter cable 0.4m, USB cable 0.5m
ACCESSORY DEVICES	Adapter

NOTE:

1. This report is prepared for FCC class II permissive change. The difference compared with the original report is adding frequency band from 5.27 to 5.31GHz and 5.51 to 5.67GHz by software.
2. All models are electrically identical, different model name, product name & brand name are for marketing purpose

BRAND	PRODUCT NAME	MODELNAME
QMI	Wireless HDMI Receiver	HB557
HP	TV Adaptor	HSTNN-QR02

3. The EUT is a Wireless HDMI Receiver. The test data are separated into following test reports.

	TEST STANDARD	REFERENCE REPORT
WLAN 802.11a	FCC Part 15, Subpart E (Section 15.407)	RF990714C11A
WLAN 802.11a (For DFS report)		RF990714C11A-1

4. The EUT provides one completed transmitter and five receivers.
5. The EUT was powered by the following adapter:

BRAND:	HON KWANG
MODEL:	HK-R110-A05
INPUT:	100-240Vac, 50/60Hz, 0.5A
OUTPUT:	5Vdc, 2A
POWER LINE:	1.8m non-shielded cable without core

6. The above EUT information was declared by manufacturer and for more detailed features description, please refer to the manufacturer's specifications or user's manual.

3.2 DESCRIPTION OF TEST MODES

Operated in 5270 ~ 5310MHz

2 channels are provided as below:

CHANNEL	FREQUENCY	CHANNEL	FREQUENCY
54	5270 MHz	62	5310 MHz

Operated in 5510 ~ 5670MHz

3 channels re provided as below:

CHANNEL	FREQUENCY	CHANNEL	FREQUENCY
102	5510 MHz	134	5670 MHz
110	5550 MHz		

3.2.1 CONFIGURATION OF SYSTEM UNDER TEST

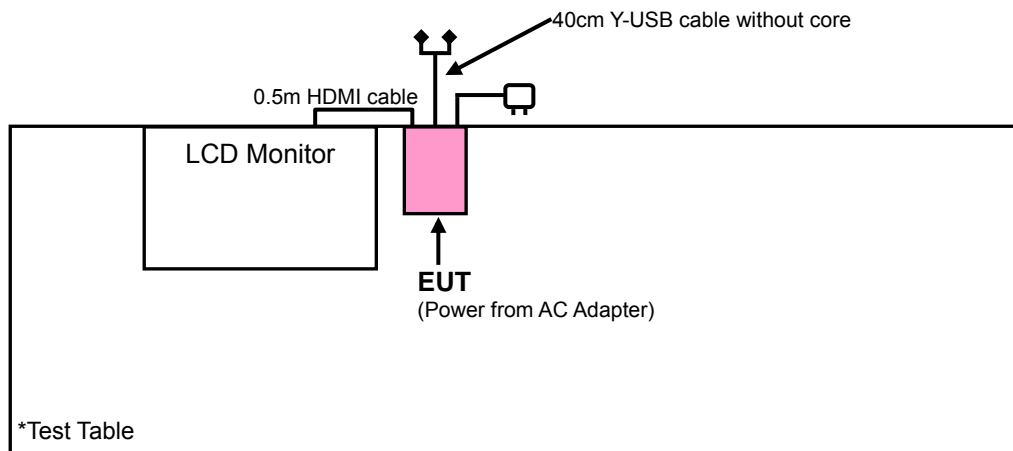

3.2.2 TEST MODE APPLICABILITY AND TESTED CHANNEL DETAIL

EUT CONFIGURE MODE	APPLICABLE TO				DESCRIPTION
	RE≥1G	RE<1G	PLC	APCM	
-	√	√	√	√	-

Where **RE≥1G**: Radiated Emission above 1GHz **RE<1G**: Radiated Emission below 1GHz
PLC: Power Line Conducted Emission **APCM**: Antenna Port Conducted Measurement

RADIATED EMISSION TEST (ABOVE 1GHz):

- Pre-Scan has been conducted to determine the worst-case mode from all possible combinations between available modulations, XYZ axis and antenna ports (if EUT with antenna diversity architecture).
- Following channel(s) was (were) selected for the final test as listed below.

FREQ. BAND (MHz)	AVAILABLE CHANNEL	TESTED CHANNEL	MODULATION TECHNOLOGY	MODULATION TYPE	DATA RATE (kbps)	AXIS
5270-5310	54 to 62	54, 62	OFDM	OOK	60	Z
5510-5670	102 to 134	102, 110, 134	OFDM	OOK	60	Z

RADIATED EMISSION TEST (BELOW 1GHz):

- Pre-Scan has been conducted to determine the worst-case mode from all possible combinations between available modulations, data rates and antenna ports (if EUT with antenna diversity architecture).
- Following channel(s) was (were) selected for the final test as listed below.

FREQ. BAND (MHz)	AVAILABLE CHANNEL	TESTED CHANNEL	MODULATION TECHNOLOGY	MODULATION TYPE	DATA RATE (kbps)	AXIS
5270-5310	54 to 62	62	OFDM	OOK	60	Z
5510-5670	102 to 134	110	OFDM	OOK	60	Z

POWER LINE CONDUCTED EMISSION TEST:

- Pre-Scan has been conducted to determine the worst-case mode from all possible combinations between available modulations, data rates and antenna ports (if EUT with antenna diversity architecture).
- Following channel(s) was (were) selected for the final test as listed below.

FREQ. BAND (MHz)	AVAILABLE CHANNEL	TESTED CHANNEL	MODULATION TECHNOLOGY	MODULATION TYPE	DATA RATE (kbps)
5270-5310	54 to 62	62	OFDM	OOK	60
5510-5670	102 to 134	110	OFDM	OOK	60

BANDEDGE MEASUREMENT:

- Pre-Scan has been conducted to determine the worst-case mode from all possible combinations between available modulations, data rates and antenna ports (if EUT with antenna diversity architecture).
- Following channel(s) was (were) selected for the final test as listed below.

FREQ. BAND (MHz)	AVAILABLE CHANNEL	TESTED CHANNEL	MODULATION TECHNOLOGY	MODULATION TYPE	DATA RATE (kbps)
5270-5310	54 to 62	54, 62	OFDM	OOK	60
5510-5670	102 to 134	102, 134	OFDM	OOK	60

ANTENNA PORT CONDUCTED MEASUREMENT:

- This item includes all test value of each mode, but only includes spectrum plot of worst value of each mode.
- Pre-Scan has been conducted to determine the worst-case mode from all possible combinations between available modulations, data rates and antenna ports (if EUT with antenna diversity architecture).
- Following channel(s) was (were) selected for the final test as listed below.

FREQ. BAND (MHz)	AVAILABLE CHANNEL	TESTED CHANNEL	MODULATION TECHNOLOGY	MODULATION TYPE	DATA RATE (kbps)
5270-5310	54 to 62	54, 62	OFDM	OOK	60
5510-5670	102 to 134	102, 110, 134	OFDM	OOK	60

TEST CONDITION:

APPLICABLE TO	ENVIRONMENTAL CONDITIONS	INPUT POWER (SYSTEM)	TESTED BY
RE≥1G	25deg. C, 65%RH, 1013 hPa	120Vac, 60Hz	Sun Lin
RE<1G	25deg. C, 65%RH, 1008 hPa	120Vac, 60Hz	Brad Wu
PLC	28deg. C, 68%RH, 1015 hPa	120Vac, 60Hz	Sun Lin
APCM	25deg. C, 65%RH, 1006 hPa	120Vac, 60Hz	Brad Wu

3.3 GENERAL DESCRIPTION OF APPLIED STANDARDS

The EUT is a RF Product. According to the specifications of the manufacturer, it must comply with the requirements of the following standards:

FCC Part 15, Subpart E (15.407)
ANSI C63.4-2003

All test items have been performed and recorded as per the above standards.

NOTE: The EUT is also considered as a kind of computer peripheral, because the connection to computer is necessary for typical use. It has been verified to comply with the requirements of FCC Part 15, Subpart B, Class B (DoC). The test report has been issued separately.

3.4 DESCRIPTION OF SUPPORT UNITS

The EUT has been tested as an independent unit together with other necessary accessories or support units. The following support units or accessories were used to form a representative test configuration during the tests.

NO.	PRODUCT	BRAND	MODEL NO.	SERIAL NO.	FCC ID
1	LCD MONITOR	DELL	2408FPb	CN-0G293H-74261 -874-237S-A00	FCC DoC Approved

NO.	SIGNAL CABLE DESCRIPTION OF THE ABOVE SUPPORT UNITS
1	0.5m HDMI cable without core

NOTE: All power cords of the above support units are non shielded (1.8m).

4. TEST TYPES AND RESULTS

4.1 RADIATED EMISSION MEASUREMENT

4.1.1 LIMITS OF RADIATED EMISSION MEASUREMENT

Emissions radiated outside of the specified bands, shall be according to the general radiated limits in 15.209 as following:

FREQUENCIES (MHz)	FIELD STRENGTH (microvolts/meter)	MEASUREMENT DISTANCE (meters)
0.009 ~ 0.490	2400/F(kHz)	300
0.490 ~ 1.705	24000/F(kHz)	30
1.705 ~ 30.0	30	30
30 ~ 88	100	3
88 ~ 216	150	3
216 ~ 960	200	3
Above 960	500	3

NOTE:

1. The lower limit shall apply at the transition frequencies.
2. Emission level (dBuV/m) = 20 log Emission level (uV/m).
3. As shown in 15.35(b), for frequencies above 1000MHz, the field strength limits are based on average detector, however, the peak field strength of any emission shall not exceed the maximum permitted average limits, specified above by more than 20dB under any condition of modulation.

4.1.2 LIMITS OF UNWANTED EMISSION OUT OF THE RESTRICTED BANDS

FREQUENCIES (MHz)	EIRP LIMIT (dBm)	EQUIVALENT FIELD STRENGTH AT 3m (dBμV/m) *NOTE 3
	PK	PK
5270 ~ 5310	-27	68.3
5510 ~ 5670	-27	68.3

NOTE: The following formula is used to convert the equipment isotropic radiated power (eirp) to field strength:

$$E = \frac{1000000\sqrt{30P}}{3} \mu\text{V/m, where P is the eirp (Watts).}$$

4.1.3 TEST INSTRUMENTS

DESCRIPTION & MANUFACTURER	MODEL NO.	SERIAL NO.	DATE OF CALIBRATION	DUE DATE OF CALIBRATION
Test Receiver ROHDE & SCHWARZ	ESIB7	100188	Dec. 21, 2009	Dec. 20, 2010
Spectrum Analyzer ROHDE & SCHWARZ	FSP40	100041	Jul. 09, 2010	Jul. 08, 2011
BILOG Antenna SCHWARZBECK	VULB9168	9168-156	Apr. 30, 2010	Apr. 29, 2011
HORN Antenna SCHWARZBECK	BBHA 9120 D	9120D-209	Aug. 02, 2010	Aug. 01, 2011
HORN Antenna SCHWARZBECK	BBHA 9170	BBHA9170242	Dec. 25, 2009	Dec. 24, 2010
Preamplifier Agilent	8449B	3008A01910	Sep. 09, 2010	Sep. 08, 2011
Preamplifier Agilent	8447D	2944A10638	Dec. 21, 2009	Dec. 20, 2010
RF signal cable HUBER+SUHNNER	SUCOFLEX 104	238141/4	May 14, 2010	May 13, 2011
RF signal cable HUBER+SUHNNER	SUCOFLEX 104	12738/6	May 14, 2010	May 13, 2011
Software	ADT_Radiated_ V7.6.15.9.2	NA	NA	NA
Antenna Tower EMCO	2070/2080	512.835.4684	NA	NA
Turn Table EMCO	2087-2.03	NA	NA	NA
Antenna Tower & Turn Table Controller EMCO	2090	NA	NA	NA
26GHz ~ 40GHz Amplifier	EM26400	07026401	Jul. 20, 2010	Jul. 19, 2011

- NOTE:**
1. The calibration interval of the above test instruments is 12 months and the calibrations are traceable to NML/ROC and NIST/USA.
 2. The test was performed in HwaYa Chamber 9.
 3. The horn antenna and HP preamplifier (model: 8449B) are used only for the measurement of emission frequency above 1GHz if tested.
 4. The FCC Site Registration No. is 460141.
 5. The IC Site Registration No. is IC 7450F-4.

4.1.4 TEST PROCEDURES

- a. The EUT was placed on the top of a rotating table 0.8 meters above the ground at a 3 meter semi-anechoic chamber. The table was rotated 360 degrees to determine the position of the highest radiation.
- b. The EUT was set 3 meters away from the interference-receiving antenna, which was mounted on the top of a variable-height antenna tower.
- c. The antenna is a broadband antenna, and its height is varied from one meter to four meters above the ground to determine the maximum value of the field strength. Both horizontal and vertical polarizations of the antenna are set to make the measurement.
- d. For each suspected emission, the EUT was arranged to its worst case and then the antenna was tuned to heights from 1 meter to 4 meters and the rotatable table was turned from 0 degrees to 360 degrees to find the maximum reading.
- e. The test-receiver system was set to Peak Detect Function and Specified Bandwidth with Maximum Hold Mode.
- f. If the emission level of the EUT in peak mode was 10dB lower than the limit specified, then testing could be stopped and the peak values of the EUT would be reported. Otherwise the emissions that did not have 10dB margin would be re-tested one by one using peak, quasi-peak or average method as specified and then reported in a data sheet.

NOTE:

1. The resolution bandwidth and video bandwidth of test receiver/spectrum analyzer is 120kHz for Peak detection (PK) and Quasi-peak detection (QP) at frequency below 1GHz.
2. The resolution bandwidth of test receiver/spectrum analyzer is 1MHz and video bandwidth is 3MHz for Peak detection at frequency above 1GHz.
3. The resolution bandwidth of test receiver/spectrum analyzer is 1MHz and the video bandwidth is 10Hz for Average detection (AV) at frequency above 1GHz.
4. All modes of operation were investigated and the worst-case emissions are reported.

4.1.5 DEVIATION FROM TEST STANDARD

No deviation.

4.1.6 TEST SETUP

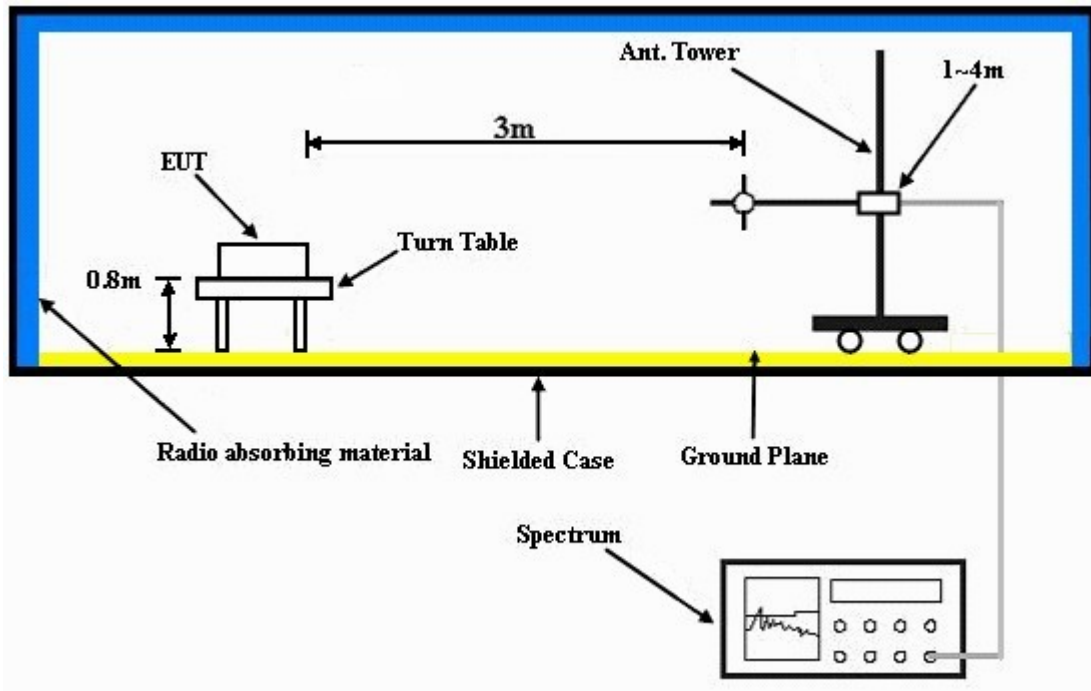

For the actual test configuration, please refer to the attached file (Test Setup Photo).

4.1.7 EUT OPERATING CONDITION

- a. Placed the EUT on the testing table & connected with LCD monitor via HDMI cable.
- b. Test laptop pc connected with EUT via console cable and ran a test program to control EUT to transmit at specific frequency and power level continuously.
- c. When EUT worked at test mode, test laptop pc disconnected with EUT and removed from the test table.

4.1.8 TEST RESULTS

EUT TEST CONDITION		MEASUREMENT DETAIL	
CHANNEL	Channel 54	FREQUENCY RANGE	1 ~ 40GHz
INPUT POWER (SYSTEM)	120Vac, 60 Hz	DETECTOR FUNCTION	Peak (PK) Average (AV)
ENVIRONMENTAL CONDITIONS	25deg. C, 65%RH 1013 hPa	TESTED BY	Sun Lin

ANTENNA POLARITY & TEST DISTANCE: HORIZONTAL AT 3 M								
NO.	FREQ. (MHz)	EMISSION LEVEL (dBuV/m)	LIMIT (dBuV/m)	MARGIN (dB)	ANTENNA HEIGHT (m)	TABLE ANGLE (Degree)	RAW VALUE (dBuV)	CORRECTION FACTOR (dB/m)
1	5150.00	46.5 PK	74.0	-27.5	1.00 H	326	7.50	39.00
2	5150.00	34.4 AV	54.0	-19.6	1.00 H	326	-4.60	39.00
3	*5270.00	105.6 PK			1.00 H	326	66.40	39.20
4	*5270.00	94.5 AV			1.00 H	326	55.30	39.20
5	#10540.00	56.1 PK	68.3	-12.2	1.23 H	35	7.00	49.10
ANTENNA POLARITY & TEST DISTANCE: VERTICAL AT 3 M								
NO.	FREQ. (MHz)	EMISSION LEVEL (dBuV/m)	LIMIT (dBuV/m)	MARGIN (dB)	ANTENNA HEIGHT (m)	TABLE ANGLE (Degree)	RAW VALUE (dBuV)	CORRECTION FACTOR (dB/m)
1	5150.00	43.1 PK	74.0	-30.9	1.02 V	45	4.10	39.00
2	5150.00	31.0 AV	54.0	-23.0	1.02 V	45	-8.00	39.00
3	*5270.00	100.7 PK			1.02 V	45	61.50	39.20
4	*5270.00	90.5 AV			1.02 V	45	51.30	39.20
5	#10540.00	56.8 PK	68.3	-11.5	1.07 V	278	7.70	49.10

- REMARKS:**
1. Emission level (dBuV/m) = Raw Value (dBuV) + Correction Factor (dB/m).
 2. Correction Factor (dB/m) = Antenna Factor (dB/m) + Cable Factor (dB).
 3. The other emission levels were very low against the limit.
 4. Margin value = Emission level – Limit value.
 5. “ * “: Fundamental frequency.
 6. “#“: The radiated frequency is out the restricted band.



A D T

EUT TEST CONDITION		MEASUREMENT DETAIL	
CHANNEL	Channel 62	FREQUENCY RANGE	1 ~ 40GHz
INPUT POWER (SYSTEM)	120Vac, 60 Hz	DETECTOR FUNCTION	Peak (PK) Average (AV)
ENVIRONMENTAL CONDITIONS	25deg. C, 65%RH 1013 hPa	TESTED BY	Sun Lin

ANTENNA POLARITY & TEST DISTANCE: HORIZONTAL AT 3 M								
NO.	FREQ. (MHz)	EMISSION LEVEL (dBuV/m)	LIMIT (dBuV/m)	MARGIN (dB)	ANTENNA HEIGHT (m)	TABLE ANGLE (Degree)	RAW VALUE (dBuV)	CORRECTION FACTOR (dB/m)
1	*5310.00	107.1 PK			1.00 H	335	67.90	39.20
2	*5310.00	96.9 AV			1.00 H	335	57.70	39.20
3	5350.00	67.1 PK	74.0	-6.9	1.00 H	334	27.80	39.30
4	5350.00	48.3 AV	54.0	-5.7	1.00 H	334	9.00	39.30
5	10620.00	57.1 PK	74.0	-16.9	1.08 H	265	7.80	49.30
6	10620.00	45.0 AV	54.0	-9.0	1.08 H	265	-4.30	49.30
ANTENNA POLARITY & TEST DISTANCE: VERTICAL AT 3 M								
NO.	FREQ. (MHz)	EMISSION LEVEL (dBuV/m)	LIMIT (dBuV/m)	MARGIN (dB)	ANTENNA HEIGHT (m)	TABLE ANGLE (Degree)	RAW VALUE (dBuV)	CORRECTION FACTOR (dB/m)
1	*5310.00	102.1 PK			1.29 V	112	62.90	39.20
2	*5310.00	91.5 AV			1.29 V	112	52.30	39.20
3	5350.00	61.2 PK	74.0	-12.8	1.28 V	112	21.90	39.30
4	5350.00	42.6 AV	54.0	-11.4	1.28 V	112	3.30	39.30
5	10620.00	55.9 PK	74.0	-18.1	1.37 V	322	6.60	49.30
6	10620.00	44.8 AV	54.0	-9.2	1.37 V	322	-4.50	49.30

- REMARKS:**
1. Emission level (dBuV/m) = Raw Value (dBuV) + Correction Factor (dB/m).
 2. Correction Factor (dB/m) = Antenna Factor (dB/m) + Cable Factor (dB).
 3. The other emission levels were very low against the limit.
 4. Margin value = Emission level – Limit value.
 5. “ * “: Fundamental frequency.



A D T

EUT TEST CONDITION		MEASUREMENT DETAIL	
CHANNEL	Channel 102	FREQUENCY RANGE	1 ~ 40GHz
INPUT POWER (SYSTEM)	120Vac, 60 Hz	DETECTOR FUNCTION	Peak (PK) Average (AV)
ENVIRONMENTAL CONDITIONS	25deg. C, 65%RH 1013 hPa	TESTED BY	Sun Lin

ANTENNA POLARITY & TEST DISTANCE: HORIZONTAL AT 3 M								
NO.	FREQ. (MHz)	EMISSION LEVEL (dBuV/m)	LIMIT (dBuV/m)	MARGIN (dB)	ANTENNA HEIGHT (m)	TABLE ANGLE (Degree)	RAW VALUE (dBuV)	CORRECTION FACTOR (dB/m)
1	5460.00	65.3 PK	74.0	-8.7	1.00 H	350	25.90	39.40
2	5460.00	44.9 AV	54.0	-9.1	1.00 H	350	5.50	39.40
3	#5470.00	67.3 PK	68.3	-1.0	1.00 H	350	27.90	39.40
4	*5510.00	105.0 PK			1.00 H	336	65.50	39.50
5	*5510.00	95.7 AV			1.00 H	336	56.20	39.50
6	11020.00	58.3 PK	74.0	-15.7	1.00 H	25	8.40	49.90
7	11020.00	48.7 AV	54.0	-5.3	1.00 H	25	-1.20	49.90
ANTENNA POLARITY & TEST DISTANCE: VERTICAL AT 3 M								
NO.	FREQ. (MHz)	EMISSION LEVEL (dBuV/m)	LIMIT (dBuV/m)	MARGIN (dB)	ANTENNA HEIGHT (m)	TABLE ANGLE (Degree)	RAW VALUE (dBuV)	CORRECTION FACTOR (dB/m)
1	5460.00	61.9 PK	74.0	-12.1	1.00 V	33	22.50	39.40
2	5460.00	42.9 AV	54.0	-11.1	1.00 V	33	3.50	39.40
3	#5470.00	65.4 PK	68.3	-2.9	1.00 V	33	26.00	39.40
4	*5510.00	101.2 PK			1.00 V	29	61.70	39.50
5	*5510.00	91.1 AV			1.00 V	29	51.60	39.50
6	11020.00	58.2 PK	74.0	-15.8	1.60 V	19	8.30	49.90
7	11020.00	46.1 AV	54.0	-7.9	1.60 V	19	-3.80	49.90

- REMARKS:**
1. Emission level (dBuV/m) = Raw Value (dBuV) + Correction Factor (dB/m).
 2. Correction Factor (dB/m) = Antenna Factor (dB/m) + Cable Factor (dB).
 3. The other emission levels were very low against the limit.
 4. Margin value = Emission level – Limit value.
 5. “ * “: Fundamental frequency.
 6. "#":The radiated frequency is out the restricted band.



A D T

EUT TEST CONDITION		MEASUREMENT DETAIL	
CHANNEL	Channel 110	FREQUENCY RANGE	1 ~ 40GHz
INPUT POWER (SYSTEM)	120Vac, 60 Hz	DETECTOR FUNCTION	Peak (PK) Average (AV)
ENVIRONMENTAL CONDITIONS	25deg. C, 65%RH 1013 hPa	TESTED BY	Sun Lin

ANTENNA POLARITY & TEST DISTANCE: HORIZONTAL AT 3 M								
NO.	FREQ. (MHz)	EMISSION LEVEL (dBuV/m)	LIMIT (dBuV/m)	MARGIN (dB)	ANTENNA HEIGHT (m)	TABLE ANGLE (Degree)	RAW VALUE (dBuV)	CORRECTION FACTOR (dB/m)
1	*5550.00	105.6 PK			1.00 H	357	66.00	39.60
2	*5550.00	96.3 AV			1.00 H	357	56.70	39.60
3	11100.00	59.2 PK	74.0	-14.8	1.12 H	57	9.20	50.00
4	11100.00	48.6 AV	54.0	-5.4	1.12 H	57	-1.40	50.00
ANTENNA POLARITY & TEST DISTANCE: VERTICAL AT 3 M								
NO.	FREQ. (MHz)	EMISSION LEVEL (dBuV/m)	LIMIT (dBuV/m)	MARGIN (dB)	ANTENNA HEIGHT (m)	TABLE ANGLE (Degree)	RAW VALUE (dBuV)	CORRECTION FACTOR (dB/m)
1	*5550.00	102.2 PK			1.07 V	36	62.60	39.60
2	*5550.00	92.3 AV			1.07 V	36	52.70	39.60
3	11100.00	57.7 PK	74.0	-16.3	1.58 V	23	7.70	50.00
4	11100.00	45.8 AV	54.0	-8.2	1.58 V	23	-4.20	50.00

- REMARKS:**
1. Emission level (dBuV/m) = Raw Value (dBuV) + Correction Factor (dB/m).
 2. Correction Factor (dB/m) = Antenna Factor (dB/m) + Cable Factor (dB).
 3. The other emission levels were very low against the limit.
 4. “ * “: Fundamental frequency.
 5. Margin value = Emission level – Limit value.



A D T

EUT TEST CONDITION		MEASUREMENT DETAIL	
CHANNEL	Channel 134	FREQUENCY RANGE	1 ~ 40GHz
INPUT POWER (SYSTEM)	120Vac, 60 Hz	DETECTOR FUNCTION	Peak (PK) Average (AV)
ENVIRONMENTAL CONDITIONS	25deg. C, 65%RH 1013 hPa	TESTED BY	Sun Lin

ANTENNA POLARITY & TEST DISTANCE: HORIZONTAL AT 3 M								
NO.	FREQ. (MHz)	EMISSION LEVEL (dBuV/m)	LIMIT (dBuV/m)	MARGIN (dB)	ANTENNA HEIGHT (m)	TABLE ANGLE (Degree)	RAW VALUE (dBuV)	CORRECTION FACTOR (dB/m)
1	*5670.00	105.7 PK			1.44 H	130	65.80	39.90
2	*5670.00	95.5 AV			1.44 H	130	55.60	39.90
3	#5725.00	59.9 PK	68.3	-8.4	1.44 H	133	19.90	40.00
4	11340.00	59.3 PK	74.0	-14.7	1.08 H	58	9.00	50.30
5	11340.00	48.3 AV	54.0	-5.7	1.08 H	58	-2.00	50.30
ANTENNA POLARITY & TEST DISTANCE: VERTICAL AT 3 M								
NO.	FREQ. (MHz)	EMISSION LEVEL (dBuV/m)	LIMIT (dBuV/m)	MARGIN (dB)	ANTENNA HEIGHT (m)	TABLE ANGLE (Degree)	RAW VALUE (dBuV)	CORRECTION FACTOR (dB/m)
1	*5670.00	101.7 PK			1.03 V	257	61.80	39.90
2	*5670.00	91.8 AV			1.03 V	257	51.90	39.90
3	#5725.00	56.8 PK	68.3	-11.5	1.03 V	253	16.80	40.00
4	11340.00	56.8 PK	74.0	-17.2	1.63 V	25	6.50	50.30
5	11340.00	45.2 AV	54.0	-8.8	1.63 V	25	-5.10	50.30

- REMARKS:**
1. Emission level (dBuV/m) = Raw Value (dBuV) + Correction Factor (dB/m).
 2. Correction Factor (dB/m) = Antenna Factor (dB/m) + Cable Factor (dB).
 3. The other emission levels were very low against the limit.
 4. Margin value = Emission level – Limit value.
 5. “ * “: Fundamental frequency.
 6. “#“: The radiated frequency is out the restricted band.



A D T

BELOW 1GHz WORST-CASE DATA :

EUT TEST CONDITION		MEASUREMENT DETAIL	
CHANNEL	Channel 62	FREQUENCY RANGE	Below 1000MHz
INPUT POWER (SYSTEM)	120Vac, 60 Hz	DETECTOR FUNCTION	Quasi-Peak
ENVIRONMENTAL CONDITIONS	25deg. C, 65%RH 1008 hPa	TESTED BY	Brad Wu

ANTENNA POLARITY & TEST DISTANCE: HORIZONTAL AT 3 M								
NO.	FREQ. (MHz)	EMISSION LEVEL (dBuV/m)	LIMIT (dBuV/m)	MARGIN (dB)	ANTENNA HEIGHT (m)	TABLE ANGLE (Degree)	RAW VALUE (dBuV)	CORRECTION FACTOR (dB/m)
1	131.00	38.0 QP	43.5	-5.5	2.00 H	145	25.80	12.20
2	249.60	36.7 QP	46.0	-9.3	1.00 H	67	23.80	12.90
3	340.99	33.5 QP	46.0	-12.5	1.50 H	181	18.80	14.70
4	399.31	31.6 QP	46.0	-14.4	2.00 H	175	15.50	16.10
5	733.73	37.0 QP	46.0	-9.0	1.00 H	223	13.40	23.60
6	930.11	33.0 QP	46.0	-13.0	1.00 H	346	6.60	26.40
ANTENNA POLARITY & TEST DISTANCE: VERTICAL AT 3 M								
NO.	FREQ. (MHz)	EMISSION LEVEL (dBuV/m)	LIMIT (dBuV/m)	MARGIN (dB)	ANTENNA HEIGHT (m)	TABLE ANGLE (Degree)	RAW VALUE (dBuV)	CORRECTION FACTOR (dB/m)
1	31.84	36.4 QP	40.0	-3.6	1.50 V	10	24.10	12.30
2	82.40	35.8 QP	40.0	-4.2	1.00 V	193	27.40	8.40
3	127.11	37.0 QP	43.5	-6.5	1.00 V	259	24.90	12.10
4	372.09	33.2 QP	46.0	-12.8	1.50 V	358	17.80	15.40
5	467.36	34.0 QP	46.0	-12.0	1.00 V	349	15.70	18.30
6	665.68	36.8 QP	46.0	-9.2	1.50 V	274	14.30	22.50

- REMARKS:**
1. Emission level (dBuV/m) = Raw Value (dBuV) + Correction Factor (dB/m).
 2. Correction Factor (dB/m) = Antenna Factor (dB/m) + Cable Factor (dB).
 3. The other emission levels were very low against the limit.
 4. Margin value = Emission level – Limit value.



A D T

EUT TEST CONDITION		MEASUREMENT DETAIL	
CHANNEL	Channel 110	FREQUENCY RANGE	Below 1000MHz
INPUT POWER (SYSTEM)	120Vac, 60 Hz	DETECTOR FUNCTION	Quasi-Peak
ENVIRONMENTAL CONDITIONS	25deg. C, 65%RH 1008 hPa	TESTED BY	Brad Wu

ANTENNA POLARITY & TEST DISTANCE: HORIZONTAL AT 3 M								
NO.	FREQ. (MHz)	EMISSION LEVEL (dBuV/m)	LIMIT (dBuV/m)	MARGIN (dB)	ANTENNA HEIGHT (m)	TABLE ANGLE (Degree)	RAW VALUE (dBuV)	CORRECTION FACTOR (dB/m)
1	134.89	38.9 QP	43.5	-4.6	2.00 H	166	26.50	12.40
2	249.60	35.9 QP	46.0	-10.1	1.00 H	346	23.00	12.90
3	475.14	31.4 QP	46.0	-14.6	2.00 H	10	12.90	18.50
4	665.68	32.6 QP	46.0	-13.4	1.00 H	355	10.10	22.50
5	731.79	35.1 QP	46.0	-10.9	1.00 H	340	11.50	23.60
6	867.89	32.6 QP	46.0	-13.4	1.00 H	10	6.70	25.90
ANTENNA POLARITY & TEST DISTANCE: VERTICAL AT 3 M								
NO.	FREQ. (MHz)	EMISSION LEVEL (dBuV/m)	LIMIT (dBuV/m)	MARGIN (dB)	ANTENNA HEIGHT (m)	TABLE ANGLE (Degree)	RAW VALUE (dBuV)	CORRECTION FACTOR (dB/m)
1	30.00	36.4 QP	40.0	-3.6	2.00 V	148	24.10	12.30
2	82.40	36.2 QP	40.0	-3.8	2.00 V	10	27.80	8.40
3	115.45	38.6 QP	43.5	-4.9	1.00 V	10	27.40	11.20
4	467.36	34.0 QP	46.0	-12.0	1.00 V	193	15.70	18.30
5	568.47	32.3 QP	46.0	-13.7	1.50 V	343	11.10	21.20
6	867.89	33.2 QP	46.0	-12.8	1.00 V	307	7.30	25.90

- REMARKS:**
1. Emission level (dBuV/m) = Raw Value (dBuV) + Correction Factor (dB/m).
 2. Correction Factor (dB/m) = Antenna Factor (dB/m) + Cable Factor (dB).
 3. The other emission levels were very low against the limit.
 4. Margin value = Emission level – Limit value.

4.2 CONDUCTED EMISSION MEASUREMENT

4.2.1 LIMITS OF CONDUCTED EMISSION MEASUREMENT

FREQUENCY OF EMISSION (MHz)	CONDUCTED LIMIT (dB μ V)	
	Quasi-peak	Average
0.15 ~ 0.5	66 to 56	56 to 46
0.5 ~ 5	56	46
5 ~ 30	60	50

- NOTE:** 1. The lower limit shall apply at the transition frequencies.
 2. The limit decreases in line with the logarithm of the frequency in the range of 0.15 to 0.50MHz.
 3. All emanations from a class A/B digital device or system, including any network of conductors and apparatus connected thereto, shall not exceed the level of field strengths specified above.

4.2.2 TEST INSTRUMENTS

DESCRIPTION & MANUFACTURER	MODEL NO.	SERIAL NO.	DATE OF CALIBRATION	DUE DATE OF CALIBRATION
Test Receiver ROHDE & SCHWARZ	ESCS30	100289	Nov. 23, 2009	Nov. 22, 2010
RF signal cable Woken	5D-FB	Cable-HYCO2-01	Dec. 31, 2009	Dec. 30, 2010
LISN ROHDE & SCHWARZ	ESH2-Z5	100100	Dec. 25, 2009	Dec. 24, 2010
LISN ROHDE & SCHWARZ	ESH3-Z5	100311	Jul. 08, 2010	Jul. 07, 2011
Software ADT	ADT_Cond_ V7.3.7	NA	NA	NA

- NOTE:** 1. The calibration interval of the above test instruments is 12 months and the calibrations are traceable to NML/ROC and NIST/USA.
 2. The test was performed in HwaYa Shielded Room 2.
 3. The VCCI Site Registration No. is C-2047.

4.2.3 TEST PROCEDURES

- a. The EUT was placed 0.4 meters from the conducting wall of the shielded room with EUT being connected to the power mains through a line impedance stabilization network (LISN). Other support units were connected to the power mains through another LISN. The two LISNs provide 50 ohm/ 50uH of coupling impedance for the measuring instrument.
- b. Both lines of the power mains connected to the EUT were checked for maximum conducted interference.
- c. The frequency range from 150kHz to 30MHz was searched. Emission levels under (Limit - 20dB) was not recorded.

4.2.4 DEVIATION FROM TEST STANDARD

No deviation.

4.2.5 TEST SETUP

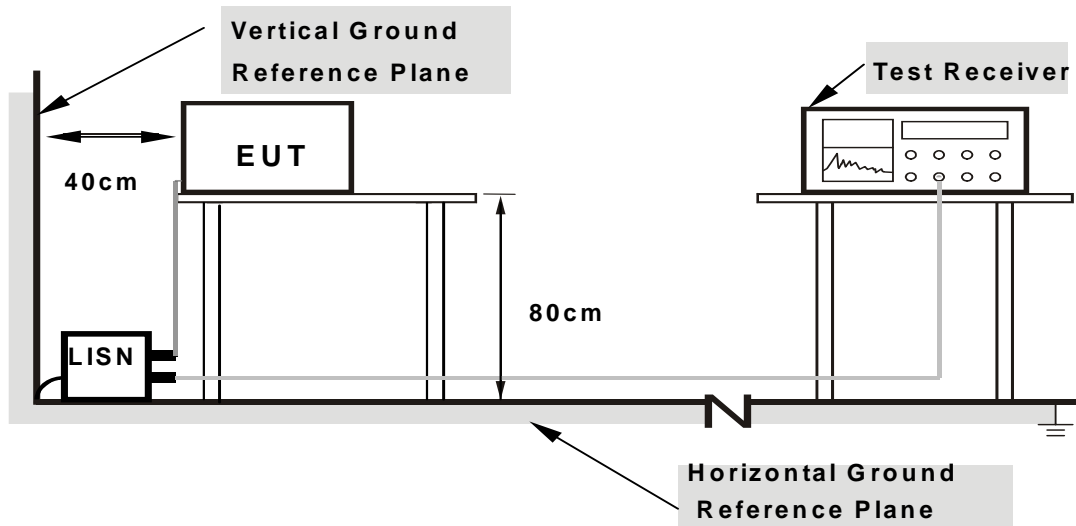

Note: 1. Support units were connected to second LISN.

2. Both of LISNs (AMN) are 80 cm from EUT and at least 80 cm from other units and other metal planes

For the actual test configuration, please refer to the attached file (Test Setup Photo).

4.2.6 EUT OPERATING CONDITIONS

Same as 4.1.6.

4.2.7 TEST RESULTS

CONDUCTED WORST-CASE DATA :

CHANNEL	Channel 62	PHASE	Line 1
6dB BANDWIDTH	9kHz		

No	Freq. [MHz]	Corr. Factor (dB)	Reading Value		Emission Level		Limit		Margin	
			[dB (uV)]		[dB (uV)]		[dB (uV)]		(dB)	
			Q.P.	AV.	Q.P.	AV.	Q.P.	AV.	Q.P.	AV.
1	0.267	0.17	35.23	-	35.40	-	61.20	51.20	-25.81	-
2	0.361	0.18	42.24	-	42.42	-	58.71	48.71	-16.29	-
3	0.513	0.19	33.62	-	33.81	-	56.00	46.00	-22.19	-
4	1.215	0.25	32.04	-	32.29	-	56.00	46.00	-23.71	-
5	1.918	0.30	31.16	-	31.46	-	56.00	46.00	-24.54	-
6	3.285	0.34	28.08	-	28.42	-	56.00	46.00	-27.58	-

- REMARKS:**
1. Q.P. and AV. are abbreviations of quasi-peak and average individually.
 2. "-": The Quasi-peak reading value also meets average limit and measurement with the average detector is unnecessary.
 3. The emission levels of other frequencies were very low against the limit.
 4. Margin value = Emission level - Limit value
 5. Correction factor = Insertion loss + Cable loss
 6. Emission Level = Correction Factor + Reading Value.

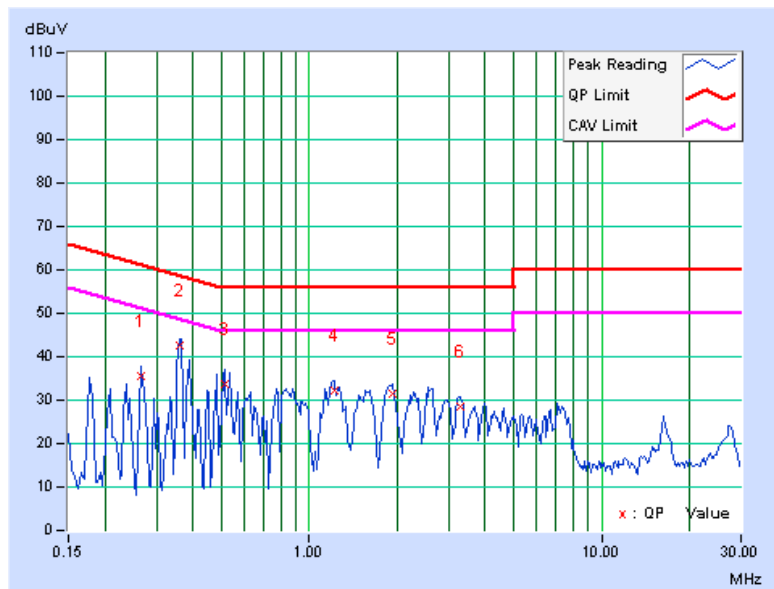



A D T

CHANNEL	Channel 62	PHASE	Line 2
6dB BANDWIDTH	9kHz		

No	Freq. [MHz]	Corr. Factor (dB)	Reading Value		Emission Level		Limit		Margin	
			[dB (uV)]		[dB (uV)]		[dB (uV)]		(dB)	
			Q.P.	AV.	Q.P.	AV.	Q.P.	AV.	Q.P.	AV.
1	0.353	0.15	42.30	-	42.45	-	58.89	48.89	-16.44	-
2	0.509	0.17	33.24	-	33.41	-	56.00	46.00	-22.59	-
3	0.888	0.21	30.63	-	30.84	-	56.00	46.00	-25.16	-
4	1.219	0.24	30.38	-	30.62	-	56.00	46.00	-25.38	-
5	1.938	0.30	29.82	-	30.12	-	56.00	46.00	-25.88	-
6	2.637	0.32	29.25	-	29.57	-	56.00	46.00	-26.43	-

- REMARKS:**
1. Q.P. and AV. are abbreviations of quasi-peak and average individually.
 2. "-": The Quasi-peak reading value also meets average limit and measurement with the average detector is unnecessary.
 3. The emission levels of other frequencies were very low against the limit.
 4. Margin value = Emission level - Limit value
 5. Correction factor = Insertion loss + Cable loss
 6. Emission Level = Correction Factor + Reading Value.

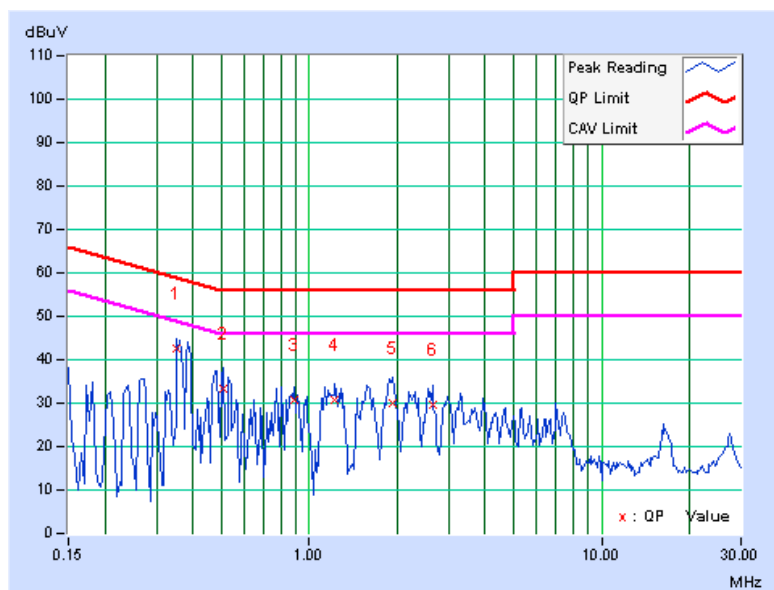

CHANNEL	Channel 110	PHASE	Line 1
6dB BANDWIDTH	9kHz		

No	Freq. [MHz]	Corr. Factor (dB)	Reading Value		Emission Level		Limit		Margin	
			[dB (uV)]		[dB (uV)]		[dB (uV)]		(dB)	
			Q.P.	AV.	Q.P.	AV.	Q.P.	AV.	Q.P.	AV.
1	0.365	0.18	35.00	-	35.18	-	58.62	48.62	-23.44	-
2	0.533	0.19	35.95	-	36.14	-	56.00	46.00	-19.86	-
3	0.841	0.22	28.96	-	29.18	-	56.00	46.00	-26.82	-
4	1.191	0.25	32.10	-	32.35	-	56.00	46.00	-23.65	-
5	1.945	0.31	30.90	-	31.21	-	56.00	46.00	-24.79	-
6	2.633	0.32	30.68	-	31.00	-	56.00	46.00	-25.00	-

- REMARKS:**
1. Q.P. and AV. are abbreviations of quasi-peak and average individually.
 2. "-": The Quasi-peak reading value also meets average limit and measurement with the average detector is unnecessary.
 3. The emission levels of other frequencies were very low against the limit.
 4. Margin value = Emission level - Limit value
 5. Correction factor = Insertion loss + Cable loss
 6. Emission Level = Correction Factor + Reading Value.

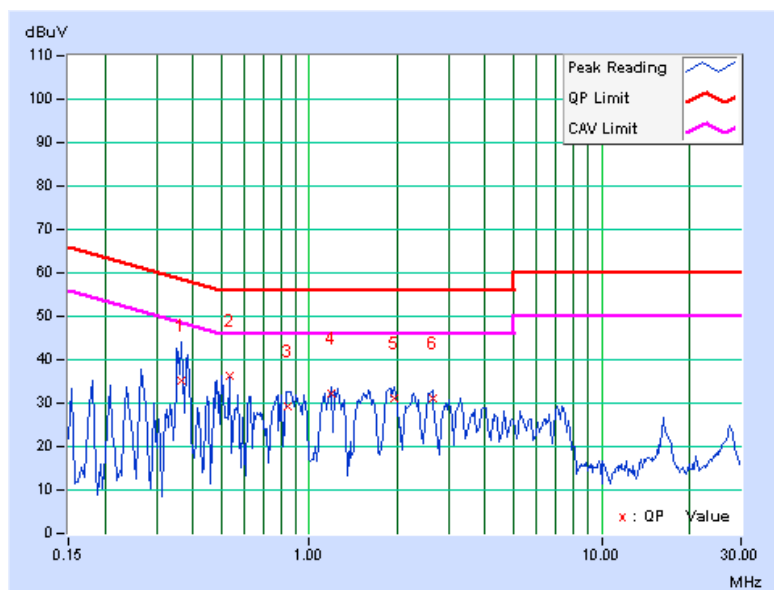

CHANNEL	Channel 110	PHASE	Line 2
6dB BANDWIDTH	9kHz		

No	Freq. [MHz]	Corr. Factor (dB)	Reading Value		Emission Level		Limit		Margin	
			[dB (uV)]		[dB (uV)]		[dB (uV)]		(dB)	
			Q.P.	AV.	Q.P.	AV.	Q.P.	AV.	Q.P.	AV.
1	0.384	0.16	41.73	-	41.89	-	58.18	48.18	-16.30	-
2	0.502	0.17	36.70	-	36.87	-	56.00	46.00	-19.13	-
3	0.857	0.21	31.69	-	31.90	-	56.00	46.00	-24.10	-
4	1.203	0.24	30.68	-	30.92	-	56.00	46.00	-25.08	-
5	1.867	0.29	30.12	-	30.41	-	56.00	46.00	-25.59	-
6	2.633	0.32	29.33	-	29.65	-	56.00	46.00	-26.35	-

- REMARKS:**
1. Q.P. and AV. are abbreviations of quasi-peak and average individually.
 2. "-": The Quasi-peak reading value also meets average limit and measurement with the average detector is unnecessary.
 3. The emission levels of other frequencies were very low against the limit.
 4. Margin value = Emission level - Limit value
 5. Correction factor = Insertion loss + Cable loss
 6. Emission Level = Correction Factor + Reading Value.

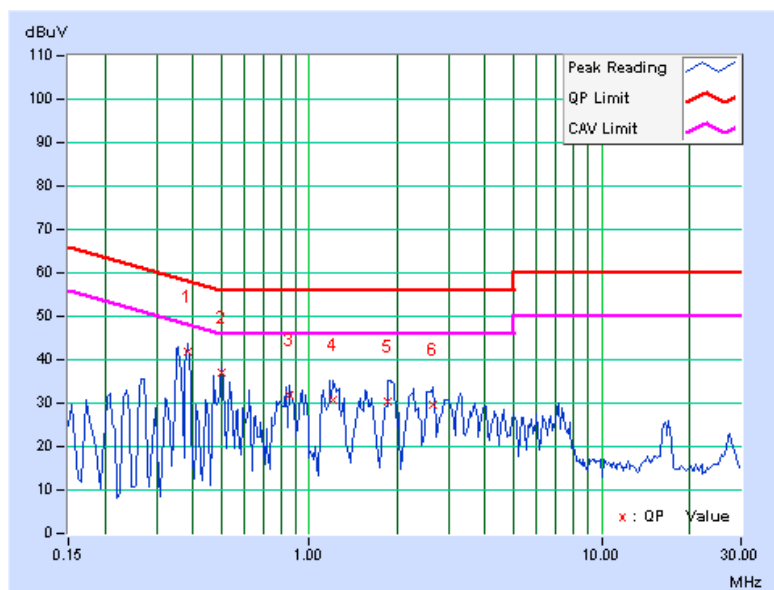

4.3 MAXIMUM CONDUCTED OUTPUT POWER MEASUREMENT

4.3.1 LIMITS OF MAXIMUM CONDUCTED OUTPUT POWER MEASUREMENT

FREQUENCY BAND	LIMIT
5.27 ~ 5.31GHz	The lesser of 250mW (24dBm) or 11dBm + 10logB
5.51 ~ 5.67GHz	The lesser of 250mW (24dBm) or 11dBm + 10logB

NOTE: Where B is the 26dB emission bandwidth in MHz.

4.3.2 TEST INSTRUMENTS

FOR POWER OUTPUT MEASUREMENT

DESCRIPTION & MANUFACTURER	MODEL NO.	SERIAL NO.	DATE OF CALIBRATION	DUE DATE OF CALIBRATION
High Speed Peak Power Meter	ML2495A	0842014	Apr. 21, 2010	Apr. 20, 2011
Power Sensor	MA2411B	0738404	Apr. 21, 2010	Apr. 20, 2011

Note:

1. The calibration interval of the above test instruments is 12 months and the calibrations are traceable to NML/ROC and NIST/USA.
2. Measurement Bandwidth of ML2495A is 65MHz greater than 26dB bandwidth of emission.

FOR 26dB OCCUPIED BANDWIDTH

DESCRIPTION & MANUFACTURER	MODEL NO.	SERIAL NO.	DATE OF CALIBRATION	DUE DATE OF CALIBRATION
R&S SPECTRUM ANALYZER	FSP40	100039	Jan. 11, 2010	Jan. 10, 2011

NOTE: The calibration interval of the above test instruments is 12 months and the calibrations are traceable to NML/ROC and NIST/USA.

4.3.3 TEST PROCEDURE

FOR POWER OUTPUT MEASUREMENT

A power sensor was used on the output port of the EUT. A power meter was used to read the response of the power sensor. Record the power level.

FOR 26dB OCCUPIED BANDWIDTH

The transmitter output was connected to the spectrum analyzer through an attenuator. The bandwidth of the fundamental frequency was measured by spectrum analyzer with 300kHz RBW and 1MHz VBW. The 26dB bandwidth is defined as the total spectrum the power of which is higher than peak power minus 26dB.

4.3.4 DEVIATION FROM TEST STANDARD

No deviation.

4.3.5 TEST SETUP

FOR POWER OUTPUT MEASUREMENT

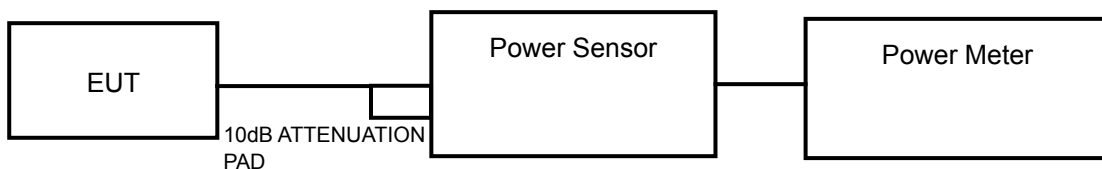

FOR 26dB OCCUPIED BANDWIDTH



4.3.6 EUT OPERATING CONDITIONS

The software provided by client to enable the EUT under transmission condition continuously at specific channel frequencies individually.



A D T

4.3.7 TEST RESULTS

FOR POWER OUTPUT MEASUREMENT:

CHAN.	CHANNEL FREQUENCY (MHz)	POWER OUTPUT (mW)	POWER OUTPUT (dBm)	POWER LIMIT (dBm)	PASS/FAIL
54	5270	20.4	13.1	24	PASS
62	5310	20.9	13.2	24	PASS
102	5510	15.8	12.0	24	PASS
110	5550	20.9	13.2	24	PASS
134	5670	20.0	13.0	24	PASS

26dB OCCUPIED BANDWIDTH:

CHANNEL	CHANNEL FREQUENCY (MHz)	26dBc OCCUPIED BANDWIDTH (MHz)	PASS / FAIL
54	5270	42.87	PASS
62	5310	43.00	PASS
102	5510	42.79	PASS
110	5550	42.89	PASS
134	5670	42.97	PASS

CH 62

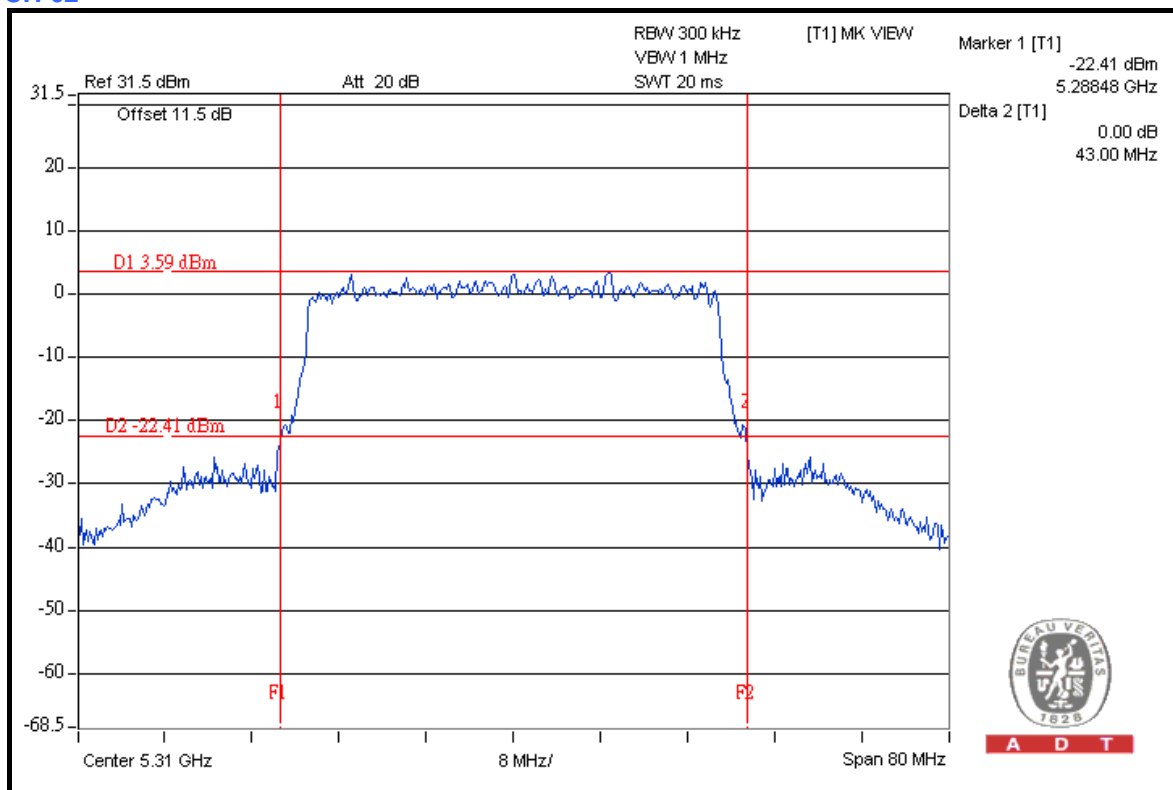

4.4 PEAK POWER EXCURSION MEASUREMENT

4.4.1 LIMITS OF PEAK POWER EXCURSION MEASUREMENT

FREQUENCY BAND	LIMIT
5.27 ~ 5.31GHz	13dB
5.51 ~ 5.67GHz	13dB

4.4.2 TEST INSTRUMENTS

DESCRIPTION & MANUFACTURER	MODEL NO.	SERIAL NO.	DATE OF CALIBRATION	DUE DATE OF CALIBRATION
R&S SPECTRUM ANALYZER	FSP40	100039	Jan. 11, 2010	Jan. 10, 2011

NOTE: The calibration interval of the above test instruments is 12 months and the calibrations are traceable to NML/ROC and NIST/USA.

4.4.3 TEST PROCEDURE

- a. The transmitter output was connected to the spectrum analyzer.
- b. Set the spectrum bandwidth span to view the entire spectrum.
- c. Using peak detector and Max-hold function for Trace 1 (RB = 1MHz, VB = 3MHz) and 2 (RB = 1MHz, VB = 300kHz).
- d. The differences between Trace1 and Trace 2 in any 1MHz band at f1 to f2 range were recorded and showed to another trace.

4.4.4 DEVIATION FROM TEST STANDARD

No deviation.

4.4.5 TEST SETUP

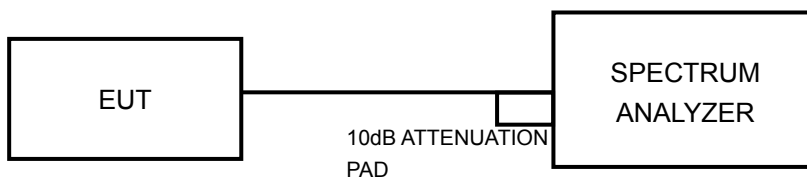

4.4.6 EUT OPERATING CONDITIONS

The software provided by client to enable the EUT under transmission condition continuously at specific channel frequencies individually.



A D T

4.4.7 TEST RESULTS

CHANNEL	CHANNEL FREQUENCY (MHz)	PEAK POWER EXCURSION (dB)	PEAK to AVERAGE EXCURSION LIMIT (dB)	PASS/FAIL
54	5270	7.63	13	PASS
62	5310	7.91	13	PASS
102	5510	7.28	13	PASS
110	5550	8.37	13	PASS
134	5670	7.90	13	PASS



A D T

CH 110

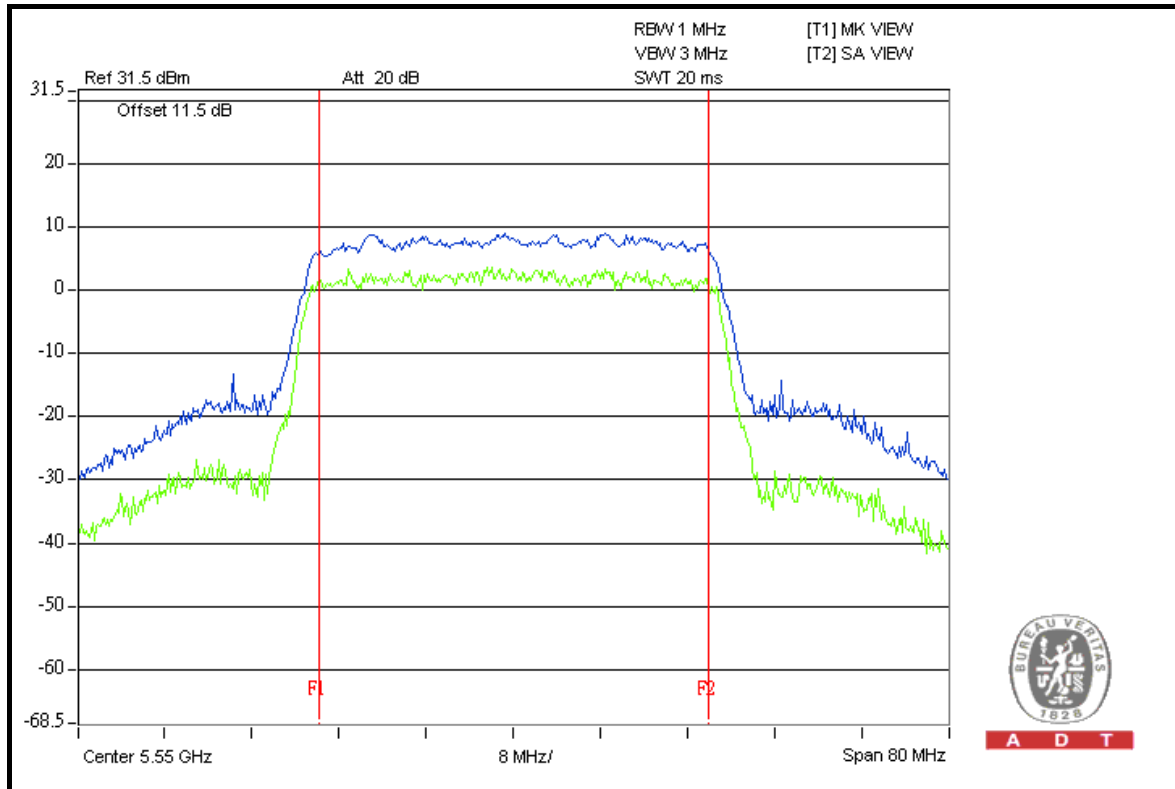

A D T

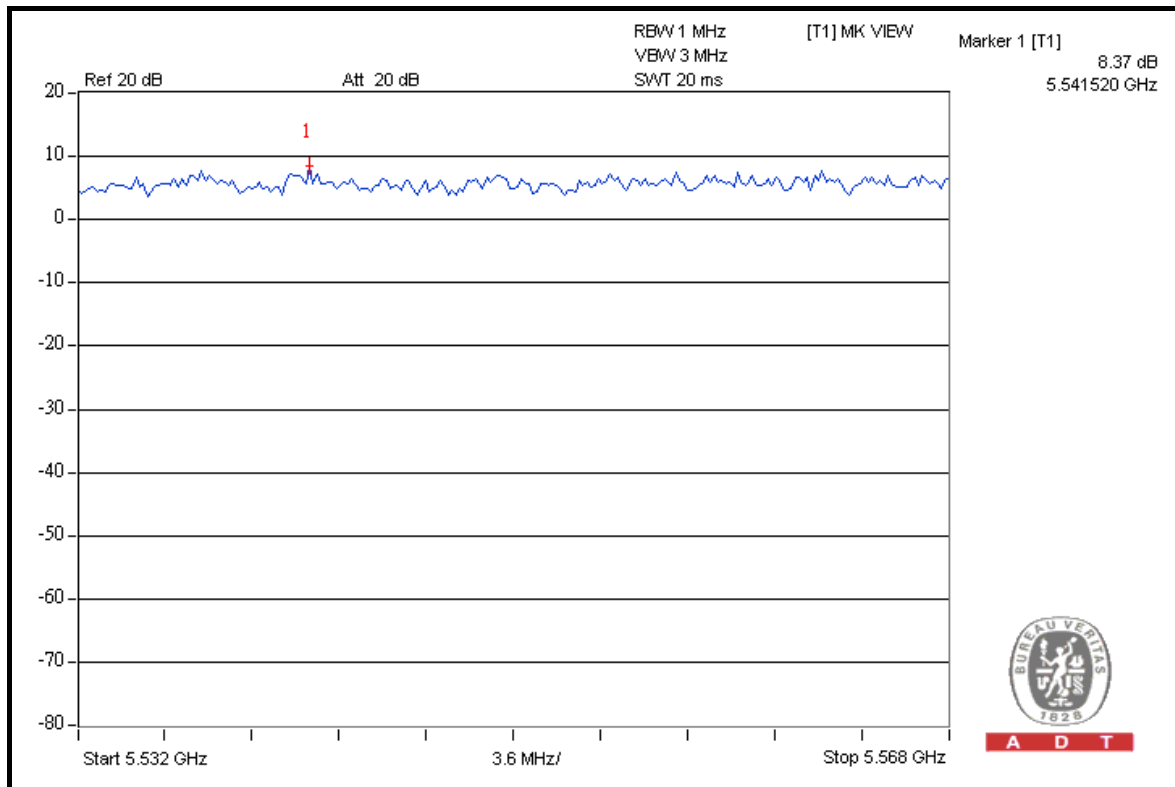

A D T

4.5 PEAK POWER SPECTRAL DENSITY MEASUREMENT

4.5.1 LIMITS OF PEAK POWER SPECTRAL DENSITY MEASUREMENT

FREQUENCY BAND	LIMIT
5.27 ~ 5.31GHz	11dBm
5.51 ~ 5.67GHz	11dBm

4.5.2 TEST INSTRUMENTS

DESCRIPTION & MANUFACTURER	MODEL NO.	SERIAL NO.	DATE OF CALIBRATION	DUE DATE OF CALIBRATION
R&S SPECTRUM ANALYZER	FSP40	100039	Jan. 11, 2010	Jan. 10, 2011

NOTE: The calibration interval of the above test instruments is 12 months and the calibrations are traceable to NML/ROC and NIST/USA.

4.5.3 TEST PROCEDURES

- a. The transmitter output was connected to the spectrum analyzer.
- b. Set RBW = 1MHz, VBW = 3MHz. The PPSD is the highest level found across the emission in any 1MHz band.

4.5.4 DEVIATION FROM TEST STANDARD

No deviation.

4.5.5 TEST SETUP

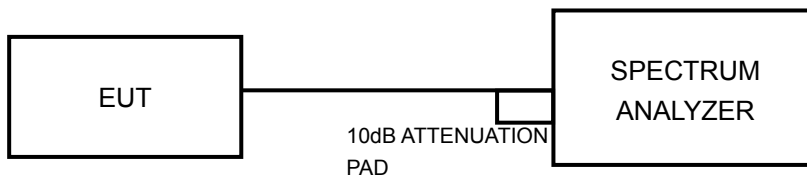

4.5.6 EUT OPERATING CONDITIONS

Same as 4.3.6.



A D T

4.5.7 TEST RESULTS

CHANNEL	CHANNEL FREQUENCY (MHz)	RF POWER LEVEL IN 3 kHz BW (dBm)	MAXIMUM LIMIT (dBm)	PASS/FAIL
54	5270	-2.31	11	PASS
62	5310	-2.21	11	PASS
102	5510	-3.36	11	PASS
110	5550	-2.16	11	PASS
134	5670	-2.39	11	PASS

CH 110

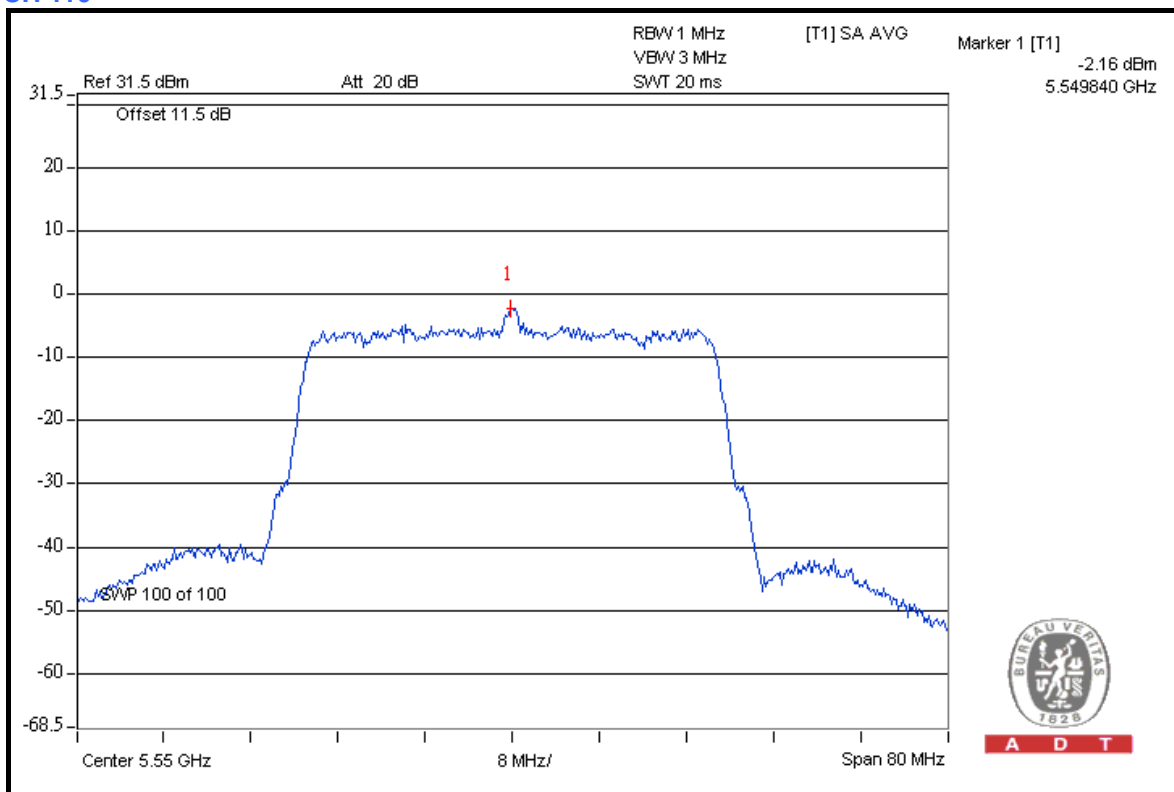

4.6 FREQUENCY STABILITY

4.6.1 LIMITS OF FREQUENCY STABILITY MEASUREMENT

The frequency tolerance of the carrier signal shall be maintained within the band of operation frequency over a temperature variation of –30 degrees to 50 degrees C at normal supply voltage, and for a variation in the primary supply voltage from 85% to 115% of the rated supply voltage at a temperature of 20 degrees C.

4.6.2 TEST INSTRUMENTS

DESCRIPTION & MANUFACTURER	MODEL NO.	SERIAL NO.	DATE OF CALIBRATION	DUE DATE OF CALIBRATION
R&S SPECTRUM ANALYZER	FSP40	100039	Jan. 11, 2010	Jan. 10, 2011
WIT STANDARD TEMPERATURE AND HUMIDITY CHAMBER	TH-4S-C	W981030	Jun. 28, 2010	Jun. 27, 2011

NOTE: The calibration interval of the above test instruments is 12 months and the calibrations are traceable to NML/ROC and NIST/USA.

4.6.3 TEST PROCEDURE

- a. The EUT was placed inside the environmental test chamber and powered by nominal DC voltage.
- b. Turn the EUT on and couple its output to a spectrum analyzer.
- c. Turn the EUT off and set the chamber to the highest temperature specified.
- d. Allow sufficient time (approximately 30 min) for the temperature of the chamber to stabilize, turn the EUT on and measure the operating frequency after 2, 5, and 10 minutes.
- e. Repeat step 2 and 3 with the temperature chamber set to the lowest temperature.
- f. The test chamber was allowed to stabilize at +20 degree C for a minimum of 30 minutes. The supply voltage was then adjusted on the EUT from 85% to 115% and the frequency record.

4.6.4 DEVIATION FROM TEST STANDARD

No deviation.

4.6.5 TEST SETUP

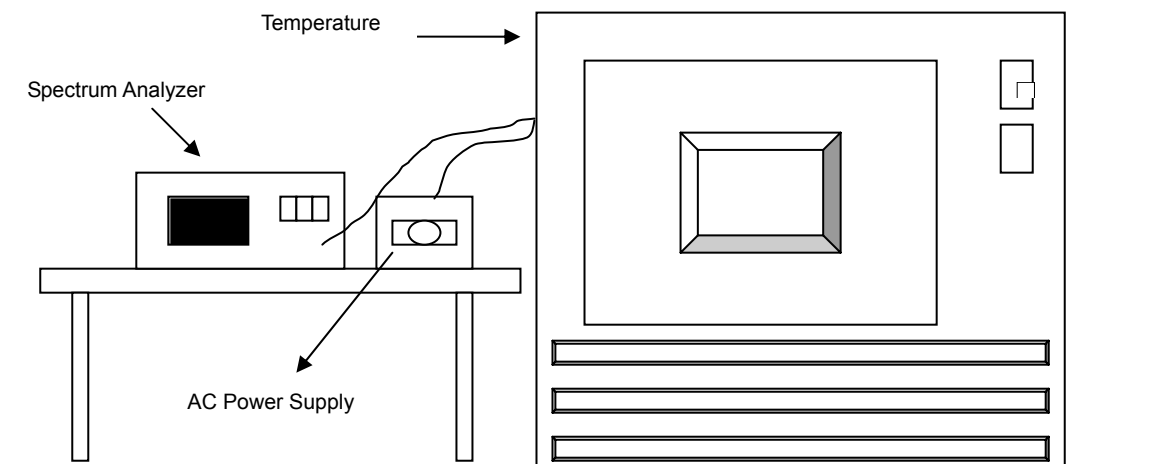

4.6.6 EUT OPERATING CONDITION

Same as Item 4.1.6.

4.6.7 TEST RESULTS

FREQUENCY STABILITY VERSUS TEMP.									
OPERATING FREQUENCY: 5310MHz									
TEMP. (°C)	POWER SUPPLY (Vac)	0 MINUTE		2 MINUTE		5 MINUTE		10 MINUTE	
		Measured Frequency (MHz)	Frequency Drift (ppm)	Measured Frequency (MHz)	Frequency Drift (ppm)	Measured Frequency (MHz)	Frequency Drift (ppm)	Measured Frequency (MHz)	Frequency Drift (ppm)
50	110.0	5309.988739	-2.121	5309.988630	-2.141	5309.988679	-2.132	5309.988486	-2.168
40	110.0	5309.988573	-2.152	5309.988609	-2.145	5309.988166	-2.229	5309.988515	-2.163
30	110.0	5309.990237	-1.839	5309.990579	-1.774	5309.989795	-1.922	5309.989842	-1.913
20	110.0	5309.991735	-1.556	5309.992077	-1.492	5309.991476	-1.605	5309.992004	-1.506
10	110.0	5309.993329	-1.256	5309.993753	-1.176	5309.993225	-1.276	5309.993583	-1.208
0	110.0	5309.990914	-1.711	5309.990742	-1.744	5309.991145	-1.668	5309.990971	-1.700
-10	110.0	5309.990257	-1.835	5309.990471	-1.795	5309.990311	-1.825	5309.990195	-1.847
-20	110.0	5309.989302	-2.015	5309.989427	-1.991	5309.988776	-2.114	5309.989109	-2.051
-30	110.0	5309.987689	-2.318	5309.987921	-2.275	5309.988053	-2.250	5309.988119	-2.237

FREQUENCY STABILITY VERSUS VOLTAGE									
OPERATING FREQUENCY: 5310MHz									
TEMP. (°C)	POWER SUPPLY (Vac)	0 MINUTE		2 MINUTE		5 MINUTE		10 MINUTE	
		Measured Frequency (MHz)	Frequency Drift (ppm)	Measured Frequency (MHz)	Frequency Drift (ppm)	Measured Frequency (MHz)	Frequency Drift (ppm)	Measured Frequency (MHz)	Frequency Drift (ppm)
20	93.5	5309.991739	-1.556	5309.991977	-1.511	5309.991899	-1.526	5309.991622	-1.578
	110.0	5309.991735	-1.556	5309.992077	-1.492	5309.991476	-1.605	5309.992004	-1.506
	126.5	5309.992103	-1.487	5309.992238	-1.462	5309.991614	-1.579	5309.991979	-1.511

4.7 BAND EDGES MEASUREMENT

4.7.1 TEST INSTRUMENTS

DESCRIPTION & MANUFACTURER	MODEL NO.	SERIAL NO.	DATE OF CALIBRATION	DUE DATE OF CALIBRATION
R&S SPECTRUM ANALYZER	FSP40	100039	Jan. 11, 2010	Jan. 10, 2011

NOTE: The calibration interval of the above test instruments is 12 months and the calibrations are traceable to NML/ROC and NIST/USA.

4.7.2 TEST PROCEDURE

The transmitter output was connected to the spectrum analyzer via a low lose cable. Set both RBW and VBW of spectrum analyzer to 1MHz and 3MHz with suitable frequency span including 200MHz bandwidth from band edge. The band edges was measured and recorded.

The spectrum plots (Peak RBW = 1MHz, VBW = 3MHz; Average RBW = 1MHz, VBW = 10Hz) are attached on the following pages.

4.7.3 EUT OPERATING CONDITION

The software provided by client to enable the EUT under transmission condition continuously at specific channel frequencies individually.

4.7.4 TEST RESULTS

For signals in the restricted bands above and below the 5.27 to 5.31GHz and 5.51 to 5.67GHz allocated band a measurement was made of the amplitude of the spurious emissions with respect to the intentional signals. The relative amplitude, in dBc, was applied to the average and peak field strength of the intentional signal made on the OATS to calculate the field strength of the unintentional signals.

The spectrum plots (Peak RBW = 1MHz, VBW = 3MHz) are attached on the following pages.

FOR 5270-5310MHz BAND:

RESTRICT BAND (4500 ~ 5150 MHz)

FREQUENCY (MHz)	FUNDAMENTAL EMISSION (dBuV/m)	DELTA (dB)	MAXIMUM FIELD STRENGTH IN RESTRICT BAND (dBuV/m)	LIMIT (dBuV/m)
5270.00 (PK)	105.6	53.40	52.20	74.00
5270.00 (AV)	94.5	56.07	38.43	54.00

RESTRICT BAND (5350 ~ 5460 MHz)

FREQUENCY (MHz)	FUNDAMENTAL EMISSION (dBuV/m)	DELTA (dB)	MAXIMUM FIELD STRENGTH IN RESTRICT BAND (dBuV/m)	LIMIT (dBuV/m)
5310.00 (PK)	107.1	39.28	67.82	74.00
5310.00 (AV)	96.9	48.11	48.79	54.00

NOTE:

- Delta = Amplitude between the peak of the fundamental and the peak of the band edge emission. Please check following 3 pages.
- Maximum field strength in restrict band = Fundamental emission – Delta.



A D T

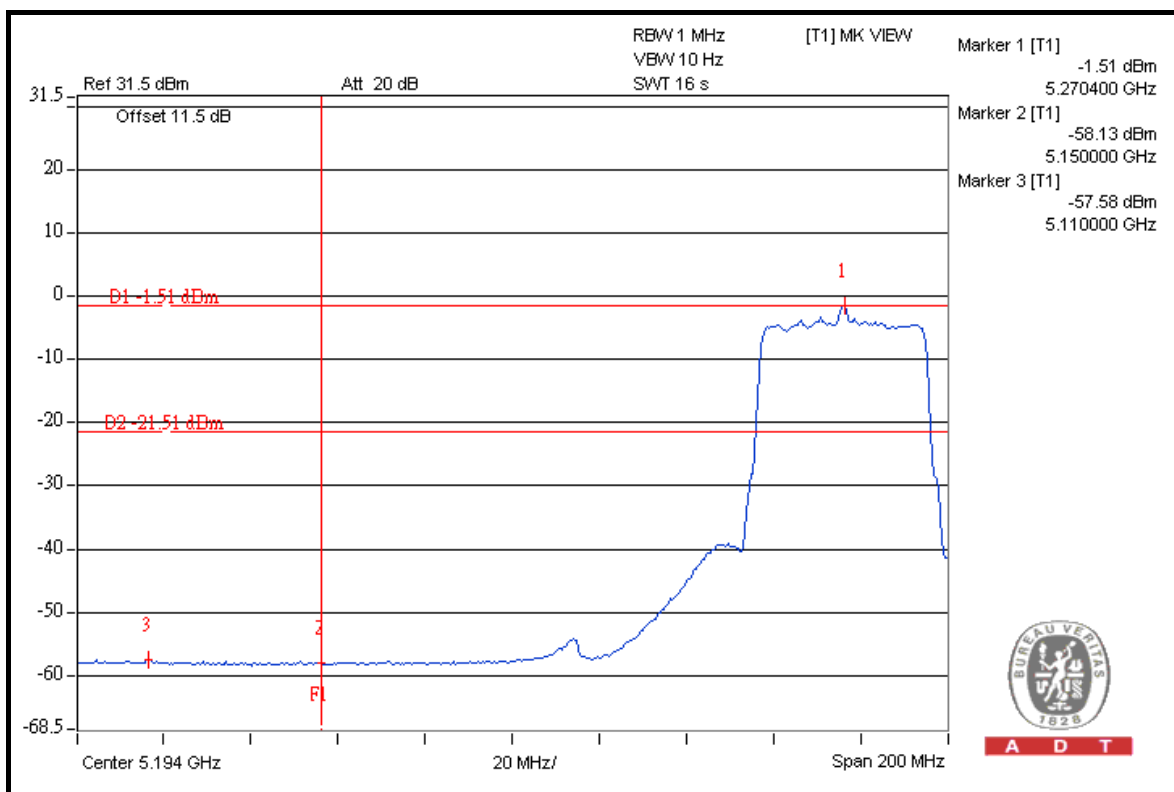
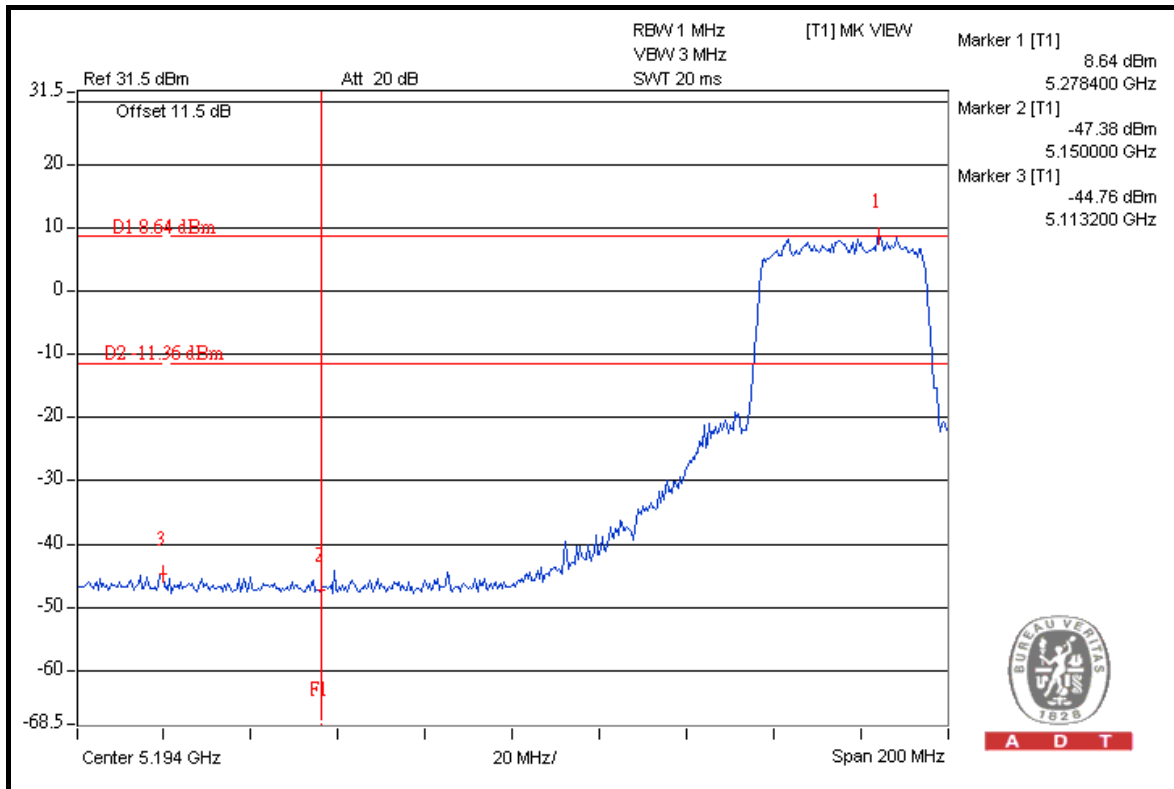



A D T

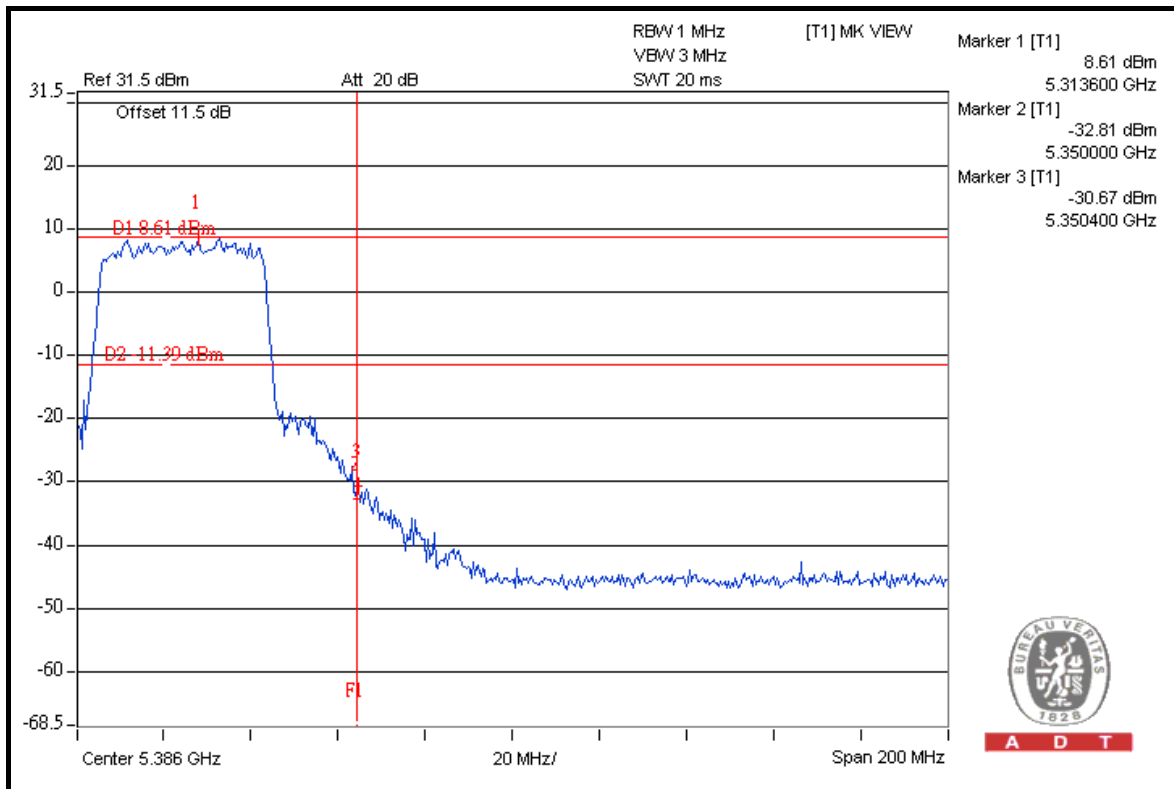
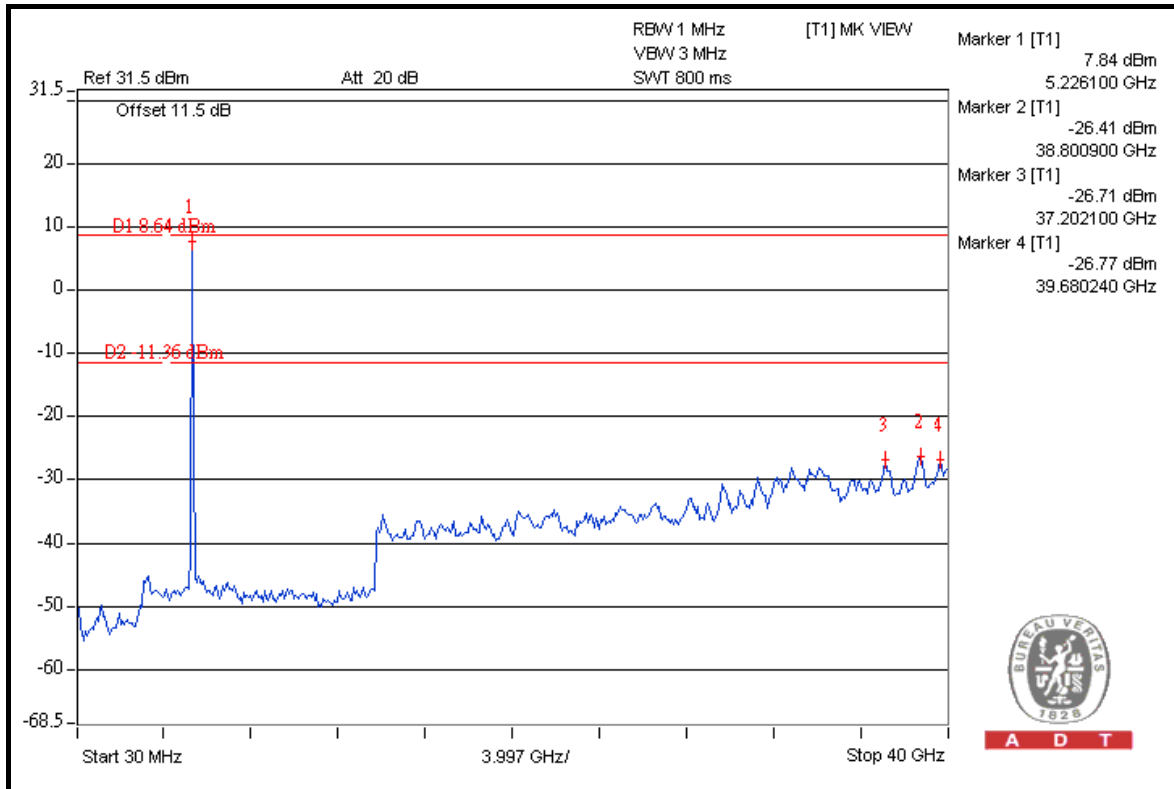



A D T

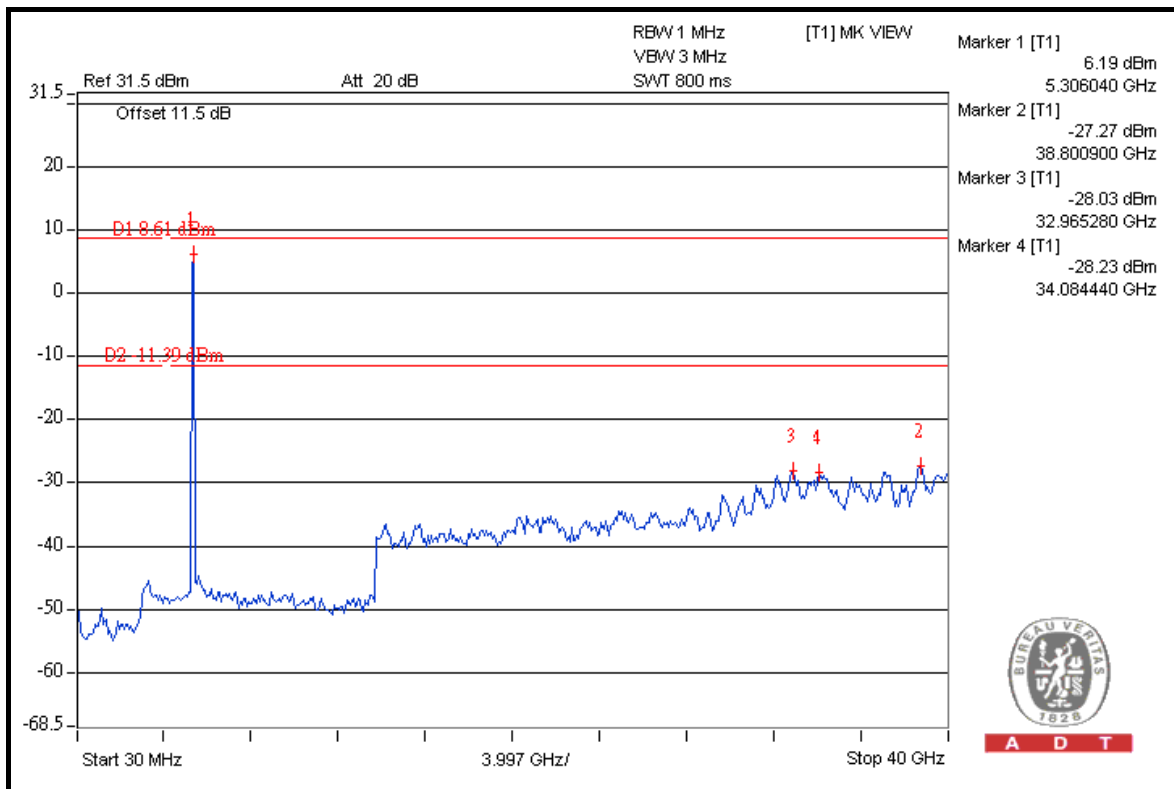
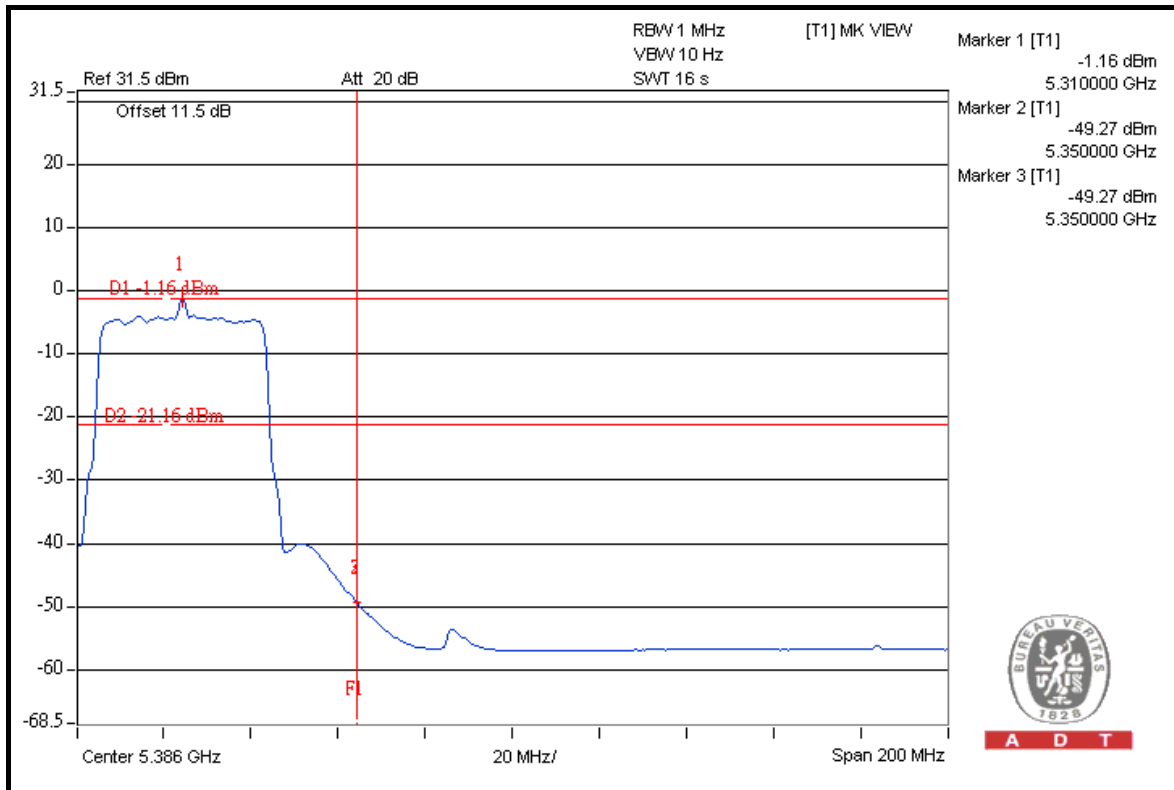

FOR 5510-5670MHz BAND:

5510MHz

RESTRICT BAND (5350 ~ 5460 MHz)

FREQUENCY (MHz)	FUNDAMENTAL EMISSION (dBuV/m)	DELTA (dB)	MAXIMUM FIELD STRENGTH IN RESTRICT BAND (dBuV/m)	LIMIT (dBuV/m)
5510.00 (PK)	105.0	45.76	59.24	74.00
5510.00 (AV)	95.7	52.91	42.79	54.00

FREQUENCY BAND (5460 ~ 5470 MHz)

FREQUENCY (MHz)	FUNDAMENTAL EMISSION (dBuV/m)	DELTA (dB)	MAXIMUM FIELD STRENGTH (dBuV/m)	LIMIT (dBuV/m)
5510.00 (PK)	105.0	38.75	66.25	68.30

5670MHz

ABOVE 5725 MHz

FREQUENCY (MHz)	FUNDAMENTAL EMISSION (dBuV/m)	DELTA (dB)	MAXIMUM FIELD STRENGTH (dBuV/m)	LIMIT (dBuV/m)
5670.00 (PK)	105.7	47.85	57.85	68.30

NOTE:

1. Delta = Amplitude between the peak of the fundamental and the peak of the band edge emission. Please check following 3 pages.
2. Maximum field strength in restrict band = Fundamental emission – Delta.



A D T

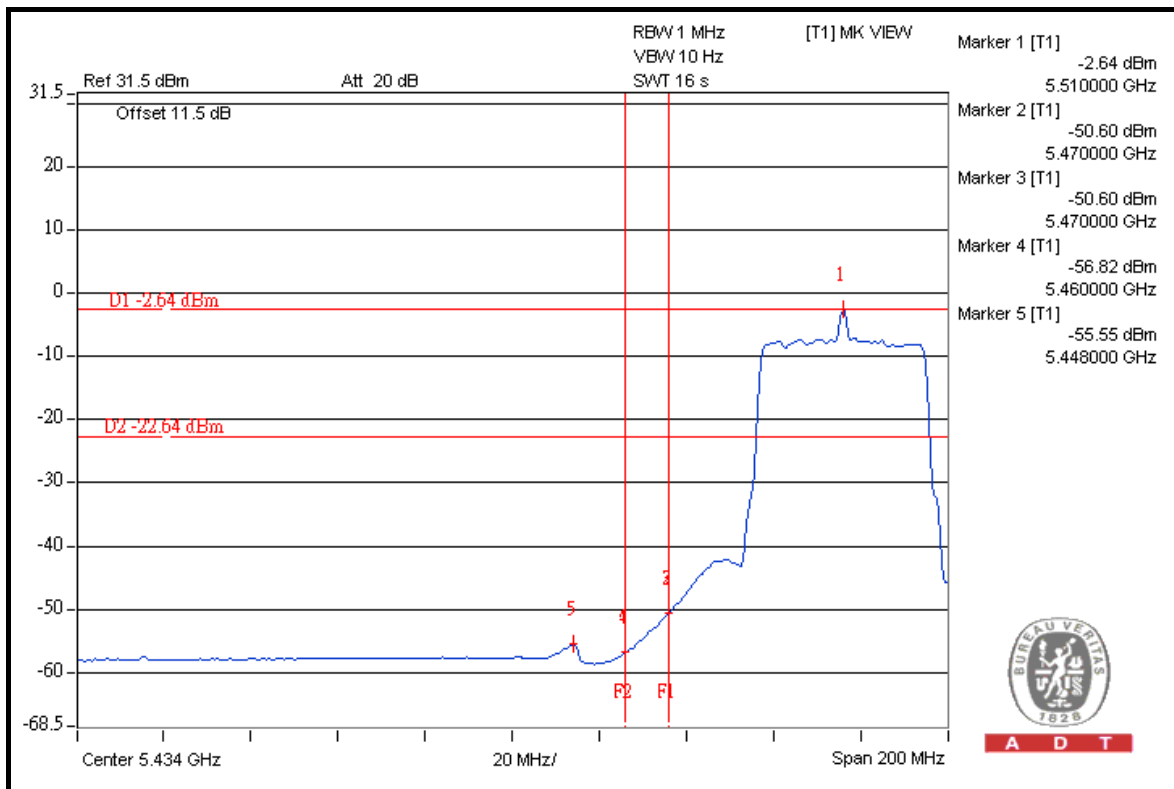
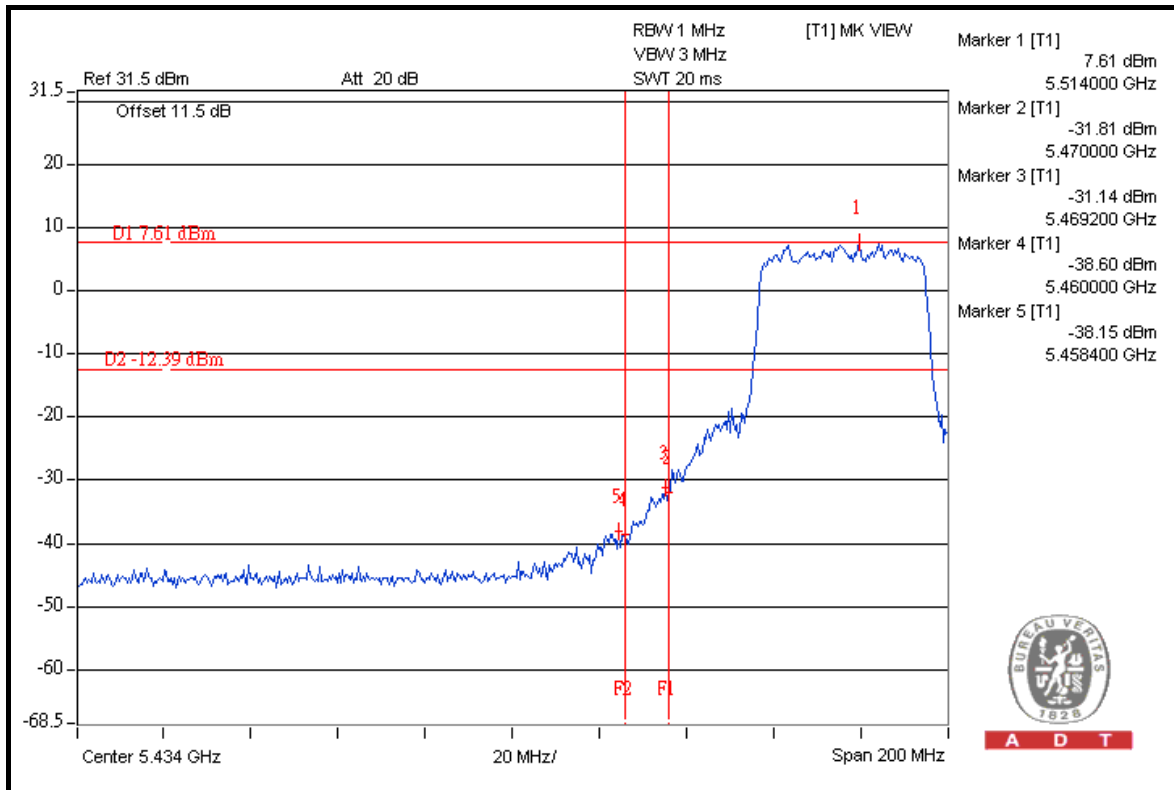



A D T

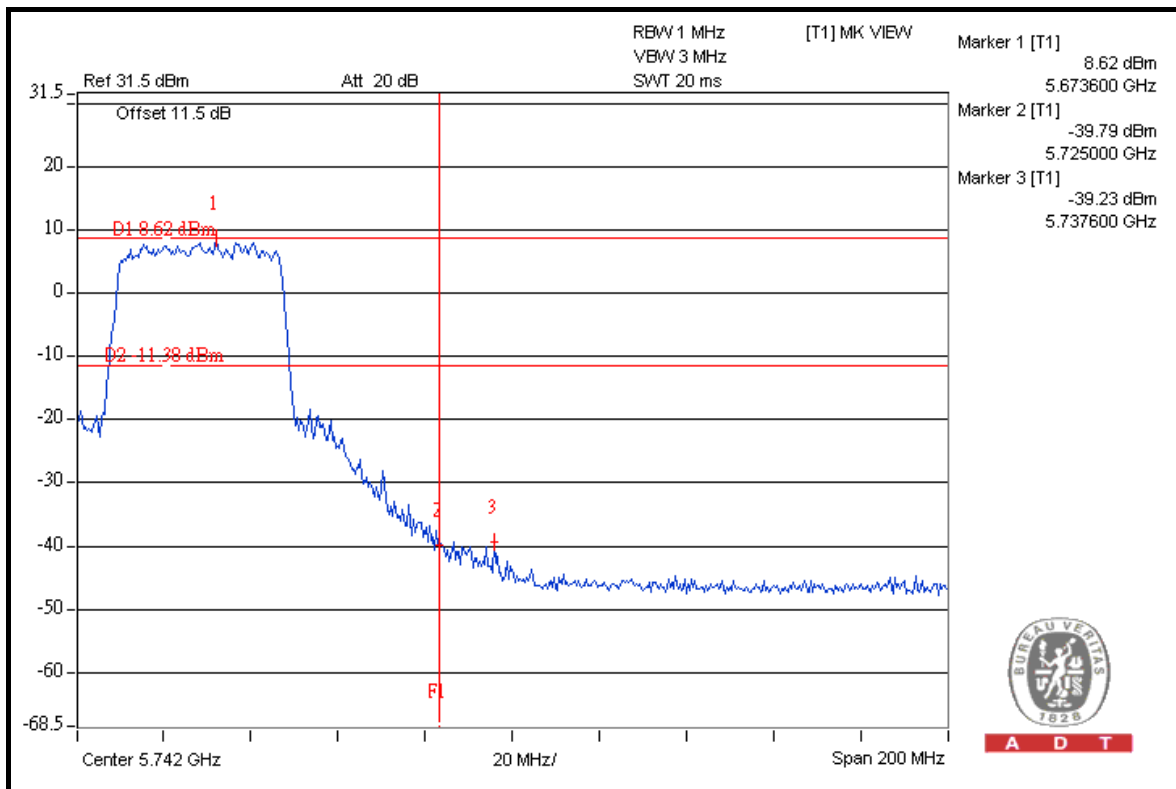
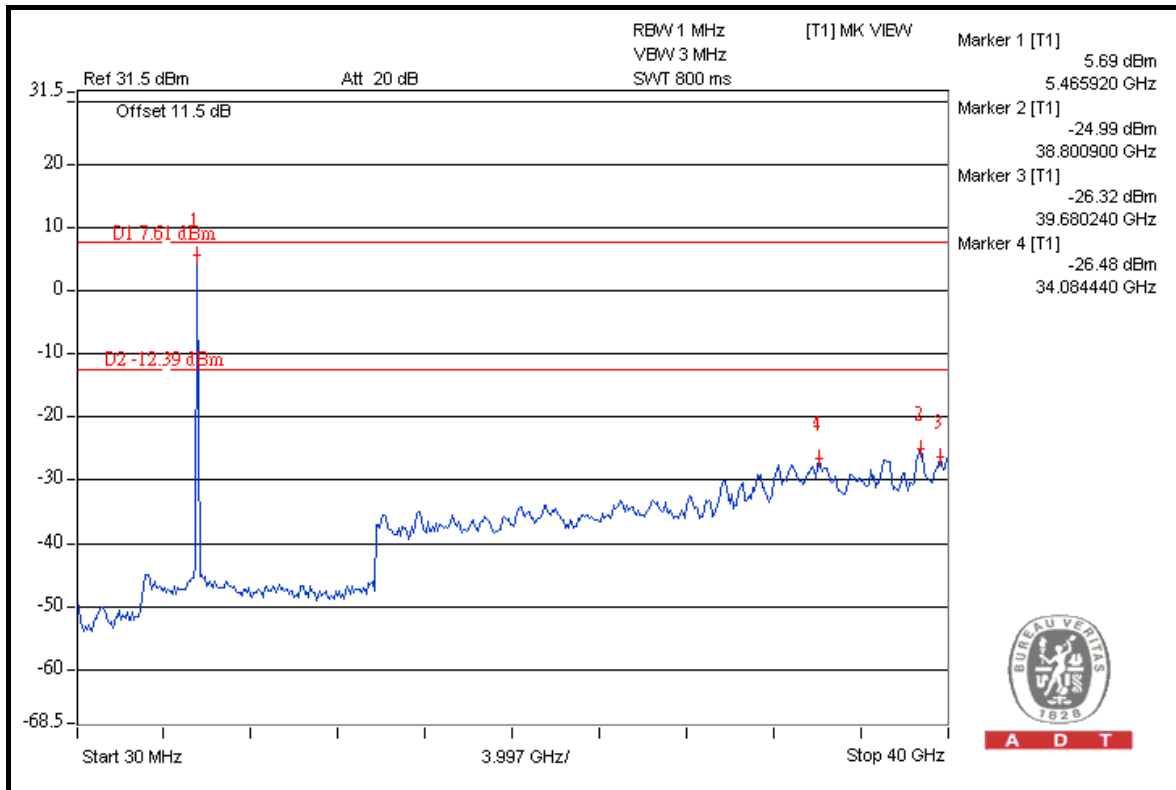



A D T

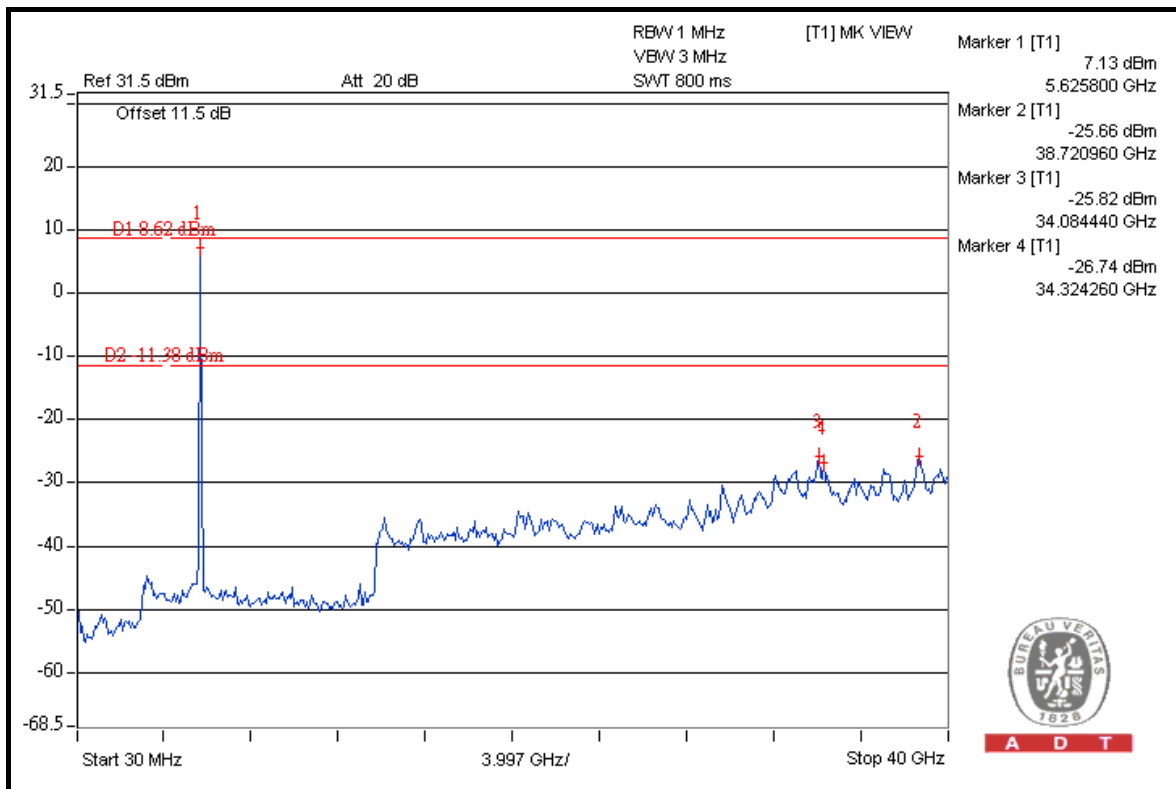
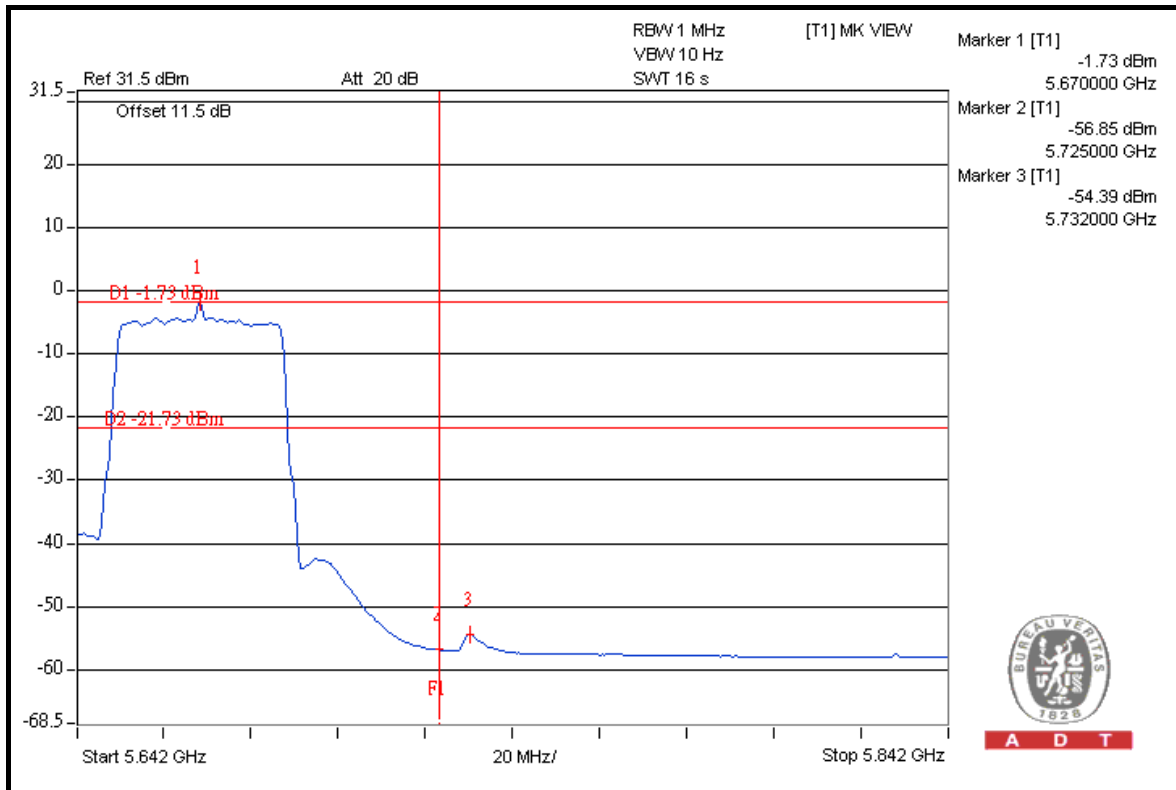

5. PHOTOGRAPHS OF THE TEST CONFIGURATION

Please refer to the attached file (Test Setup Photo).



6. INFORMATION ON THE TESTING LABORATORIES

We, Bureau Veritas Consumer Products Services (H.K.) Ltd., Taoyuan Branch, were founded in 1988 to provide our best service in EMC, Radio, Telecom and Safety consultation. Our laboratories are accredited and approved according to ISO/IEC 17025.

Copies of accreditation certificates of our laboratories obtained from approval agencies can be downloaded from our web site:
www.adt.com.tw/index.5/phtml. If you have any comments, please feel free to contact us at the following:

Linko EMC/RF Lab:

Tel: 886-2-26052180

Fax: 886-2-26051924

Hsin Chu EMC/RF Lab:

Tel: 886-3-5935343

Fax: 886-3-5935342

Hwa Ya EMC/RF/Safety Telecom Lab:

Tel: 886-3-3183232

Fax: 886-3-3185050

Web Site: www.adt.com.tw

The address and road map of all our labs can be found in our web site also.

7. APPENDIX A - MODIFICATIONS RECORDERS FOR ENGINEERING CHANGES TO THE EUT BY THE LAB

No any modifications are made to the EUT by the lab during the test.

---END---