



**FCC CFR47 PART 15 SUBPART E
INDUSTRY CANADA RSS-210 ISSUE 7
CERTIFICATION TEST REPORT**

**FOR
802.11ag/Draft 802.11n WLAN PCI-E Mini Card**

**MODEL NUMBER: BCM94322MC
FCC ID: QDS-BRCM1036
IC: 4324A-BRCM1036**

REPORT NUMBER: 07U11529-2A

ISSUE DATE: February 7, 2008

Prepared for

**BROADCOM CORPORATION
190 MATHILDA PLACE
SUNNYVALE, CA 94086, USA**

Prepared by

**COMPLIANCE CERTIFICATION SERVICES
47173 BENICIA STREET
FREMONT, CA 94538, U.S.A.
TEL: (510) 771-1000
FAX: (510) 661-0888**



NVLAP LAB CODE 200065-0

Revision History

<u>Rev.</u>	<u>Issue Date</u>	<u>Revisions</u>	<u>Revised By</u>
--	1-26-08	Initial Issue	Hsin Fu Shih
A	2-7-08	Corrected some typos. changed frequency from 5690 to 5670 MHz.	Hsin Fu Shih

TABLE OF CONTENTS

1. ATTESTATION OF TEST RESULTS	7
2. TEST METHODOLOGY	8
3. FACILITIES AND ACCREDITATION	8
4. CALIBRATION AND UNCERTAINTY	8
4.1. <i>MEASURING INSTRUMENT CALIBRATION</i>	8
4.2. <i>MEASUREMENT UNCERTAINTY</i>	8
5. EQUIPMENT UNDER TEST	9
5.1. <i>DESCRIPTION OF EUT</i>	9
5.2. <i>MAXIMUM OUTPUT POWER</i>	9
5.3. <i>DESCRIPTION OF AVAILABLE ANTENNAS</i>	10
5.4. <i>SOFTWARE AND FIRMWARE</i>	10
5.5. <i>WORST-CASE CONFIGURATION AND MODE</i>	10
5.6. <i>DESCRIPTION OF TEST SETUP</i>	11
6. TEST AND MEASUREMENT EQUIPMENT	13
7. ANTENNA PORT TEST RESULTS FOR THE 5.15–5.25 GHZ	14
7.1. <i>802.11a MODE</i>	14
7.1.1. 26 dB and 99% BANDWIDTH	14
7.1.2. OUTPUT POWER	16
7.1.3. PEAK POWER SPECTRAL DENSITY.....	19
7.1.4. PEAK EXCURSION	22
7.1.5. CONDUCTED SPURIOUS EMISSIONS.....	25
7.2. <i>802.11n HT20 MODE</i>	27
7.2.1. 26 dB and 99% BANDWIDTH	27
7.2.2. OUTPUT POWER	29
7.2.3. PEAK POWER SPECTRAL DENSITY.....	39
7.2.4. PEAK EXCURSION	44
7.2.5. CONDUCTED SPURIOUS EMISSIONS.....	49
7.3. <i>802.11n HT40 MODE</i>	51
7.3.1. 26 dB and 99% BANDWIDTH	51
7.3.2. OUTPUT POWER	53
7.3.3. PEAK POWER SPECTRAL DENSITY.....	59
7.3.4. PEAK EXCURSION	62

7.3.5. CONDUCTED SPURIOUS EMISSIONS..... 65

8. ANTENNA PORT TEST RESULTS FOR THE 5.25–5.35 GHZ..... 67

8.1. 802.11a MODE..... 67

8.1.1. 26 dB and 99% BANDWIDTH 67

8.1.2. OUTPUT POWER 69

8.1.3. PEAK POWER SPECTRAL DENSITY..... 72

8.1.4. PEAK EXCURSION 75

8.1.5. CONDUCTED SPURIOUS EMISSIONS..... 78

8.2. 802.11n HT20 MODE..... 81

8.2.1. 26 dB and 99% BANDWIDTH 81

8.2.2. OUTPUT POWER 84

8.2.3. PEAK POWER SPECTRAL DENSITY..... 92

8.2.4. PEAK EXCURSION 96

8.2.5. CONDUCTED SPURIOUS EMISSIONS..... 101

8.3. 802.11n HT40 MODE..... 105

8.3.1. 26 dB and 99% BANDWIDTH 105

8.3.2. OUTPUT POWER 107

8.3.3. PEAK POWER SPECTRAL DENSITY..... 111

8.3.4. PEAK EXCURSION 113

8.3.5. CONDUCTED SPURIOUS EMISSIONS..... 116

9. ANTENNA PORT TEST RESULTS FOR THE BAND 5.47–5.725 GHZ..... 119

9.1. 802.11a MODE..... 119

9.1.1. 26 dB and 99% BANDWIDTH 119

9.1.2. OUTPUT POWER 122

9.1.3. PEAK POWER SPECTRAL DENSITY..... 125

9.1.4. PEAK EXCURSION 128

9.1.5. CONDUCTED SPURIOUS EMISSIONS..... 131

9.2. 802.11n HT20 MODE..... 135

9.2.1. 26 dB and 99% BANDWIDTH 135

9.2.2. OUTPUT POWER 138

9.2.3. PEAK POWER SPECTRAL DENSITY..... 148

9.2.4. PEAK EXCURSION 153

9.2.5. CONDUCTED SPURIOUS EMISSIONS..... 158

9.3. 802.11n HT40 MODE..... 162

9.3.1. 26 dB and 99% BANDWIDTH 162

9.3.2.	OUTPUT POWER	165
9.3.3.	PEAK POWER SPECTRAL DENSITY	171
9.3.4.	PEAK EXCURSION	174
9.3.5.	CONDUCTED SPURIOUS EMISSIONS.....	179
10.	RADIATED TEST RESULTS.....	183
10.1.	LIMITS AND PROCEDURE	183
10.2.	TRANSMITTER ABOVE 1 GHZ FOR THE BAND 5.15–5.25 GHZ	184
10.2.1.	802.11a MODE.....	184
10.2.2.	802.11n HT20 MODE	188
10.2.3.	802.11n HT40 MODE	192
10.3.	TRANSMITTER ABOVE 1 GHZ FOR THE BAND 5.25–5.35 GHZ	196
10.3.1.	802.11a MODE.....	196
10.3.2.	802.11n HT20 MODE	200
10.3.3.	802.11n HT40 MODE	204
10.4.	TRANSMITTER ABOVE 1 GHZ FOR 5.47–5.725 GHZ BAND.....	208
10.4.1.	802.11a MODE.....	208
10.4.2.	802.11n HT20 MODE	213
10.4.3.	802.11n HT40 MODE	218
10.5.	RECEIVER ABOVE 1 GHZ	223
10.5.1.	20 MHz BANDWIDTH	223
10.5.2.	40 MHz BANDWIDTH	224
10.6.	WORST-CASE BELOW 1 GHZ.....	225
11.	DYNAMIC FREQUENCY SELECTION	227
11.1.	OVERVIEW.....	227
11.1.1.	LIMITS.....	227
11.1.2.	TEST AND MEASUREMENT SYSTEM.....	232
11.1.3.	SETUP OF EUT	235
11.1.4.	DESCRIPTION OF EUT	237
11.2.	RESULTS FOR 20 MHz BANDWIDTH	239
11.2.1.	TEST CHANNEL	239
11.2.2.	PLOTS OF RADAR WAVEFORM AND WLAN TRAFFIC.....	239
11.2.3.	MOVE AND CLOSING TIME.....	241
11.2.4.	SLAVE NON-OCCUPANCY.....	246
11.3.	RESULTS FOR 40 MHz BANDWIDTH.....	248
11.3.1.	TEST CHANNEL	248

11.3.2.	PLOTS OF RADAR WAVEFORM AND WLAN TRAFFIC	248
11.3.3.	MOVE AND CLOSING TIME.....	250
11.3.4.	SLAVE NON-OCCUPANCY.....	255
12.	AC POWER LINE CONDUCTED EMISSIONS	257
13.	MAXIMUM PERMISSIBLE EXPOSURE	260
14.	SETUP PHOTOS	264

1. ATTESTATION OF TEST RESULTS

COMPANY NAME: BROADCOM CORPORATION
190 MATHILDA PLACE
SUNNYVALE, CA 94086, USA

EUT DESCRIPTION: 802.11ag / Draft 802n WLAN PCI-E MINI CARD

MODEL: BCM94322MC

SERIAL NUMBER: P208 _S/N 194

DATE TESTED: DECEMBER 09 to JANUARY 23, 2008

APPLICABLE STANDARDS	
STANDARD	TEST RESULTS
CFR 47 Part 15 Subpart E	No Non-Compliance Noted
RSS-210 Issue 7 Annex 9 and RSS-GEN Issue 2	No Non-Compliance Noted

Compliance Certification Services, Inc. tested the above equipment in accordance with the requirements set forth in the above standards. The test results show that the equipment tested is capable of demonstrating compliance with the requirements as documented in this report.

Note: The results documented in this report apply only to the tested sample, under the conditions and modes of operation as described herein. This document may not be altered or revised in any way unless done so by Compliance Certification Services and all revisions are duly noted in the revisions section. Any alteration of this document not carried out by Compliance Certification Services will constitute fraud and shall nullify the document. No part of this report may be used to claim product certification, approval, or endorsement by NVLAP, NIST, or any government agency.

Approved & Released For CCS By:

Tested By:

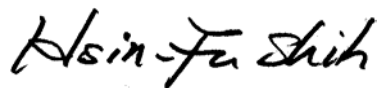

HSIN FU SHIH
EMC SUPERVISOR
COMPLIANCE CERTIFICATION SERVICES

VIEN TRAN
EMC ENGINEER
COMPLIANCE CERTIFICATION SERVICES

2. TEST METHODOLOGY

The tests documented in this report were performed in accordance with ANSI C63.4-2003, FCC CFR 47 Part 2, FCC CFR 47 Part 15, FCC MO&O 06-96, RSS-GEN Issue 2, and RSS-210 Issue 7.

3. FACILITIES AND ACCREDITATION

The test sites and measurement facilities used to collect data are located at 47173 Benicia Street, Fremont, California, USA.

CCS is accredited by NVLAP, Laboratory Code 200065-0. The full scope of accreditation can be viewed at <http://www.ccsemc.com>.

4. CALIBRATION AND UNCERTAINTY

4.1. MEASURING INSTRUMENT CALIBRATION

The measuring equipment utilized to perform the tests documented in this report has been calibrated in accordance with the manufacturer's recommendations, and is traceable to recognized national standards.

4.2. MEASUREMENT UNCERTAINTY

Where relevant, the following measurement uncertainty levels have been estimated for tests performed on the apparatus:

PARAMETER	UNCERTAINTY
Power Line Conducted Emission	+/- 2.3 dB
Radiated Emission	+/- 3.4 dB

Uncertainty figures are valid to a confidence level of 95%.

5. EQUIPMENT UNDER TEST

5.1. DESCRIPTION OF EUT

The EUT is an 802.11ag/Draft 802.11n Wireless LAN transceiver card and manufactured by Broadcom. Model number is BCM94322MC.

5.2. MAXIMUM OUTPUT POWER

The transmitter has a maximum conducted output power as follows:

5150 to 5250 MHz Authorized Band					
Frequency Range (MHz)	Mode	Peak Power Chain 0 (dBm)	Peak Power Chain 1 (dBm)	Total Peak Power (dBm)	Output Power (mW)
5180 - 5240	802.11a Legacy	N/A	N/A	14.33	27.10
5180 - 5240	802.11n 20MHz SISO	covered by the worst case 802.11a Legacy testing			
5190 - 5230	802.11n 40MHz SISO	N/A	N/A	N/A	N/A
5180 - 5240	802.11a CDD Mode	covered by the worst case 802.11n 20 MHz CDD			
Power with Antenna Array Gain up to 6 dBi					
5180 - 5240	802.11n 20MHz CDD	10.20	10.14	13.18	20.80
5190 - 5230	802.11n 40MHz CDD	12.12	12.26	15.20	33.12
Power with Antenna Array Gain up to 8.61 dBi					
5180 - 5240	802.11n 20MHz CDD	8.35	8.14	11.26	13.36
5190 - 5230	802.11n 40MHz CDD	11.19	11.33	14.27	26.74

5250 - 5350 MHz Authorized Band

Frequency Range (MHz)	Mode	Peak Power Chain 0 (dBm)	Peak Power Chain 1 (dBm)	Total Peak Power (dBm)	Output Power (mW)
5260 - 5320	802.11a Legacy	N/A	N/A	17.80	60.26
5260 - 5320	802.11n 20MHz SISO	covered by the worst case 802.11a Legacy testing			
5270 -5310	802.11n 40MHz SISO	N/A	N/A	N/A	N/A
5260 - 5320	802.11a CDD Mode	covered by the worst case 802.11n 20 MHz CDD			
Power with Antenna Array Gain up to 6 dBi					
5260 - 5320	802.11n 20MHz CDD	16.20	16.16	19.19	82.99
5270 -5310	802.11n 40MHz CDD	17.19	17.28	20.25	105.82
Power with Antenna Array Gain up to 8.61 dBi					
5260 - 5320	802.11n 20MHz CDD	15.29	15.17	18.24	66.69
5270 -5310	802.11n 40MHz CDD	17.19	17.28	20.25	105.82

5470 - 5725 MHz Authorized Band

Frequency Range (MHz)	Mode	Peak Power Chain 0 (dBm)	Peak Power Chain 1 (dBm)	Total Peak Power (dBm)	Output Power (mW)
5500 - 5700	802.11a Legacy	N/A	N/A	18.15	65.31
5500 - 5700	802.11n 20MHz SISO	covered by the worst case 802.11a Legacy testing			
5510 - 5670	802.11n 40MHz SISO	N/A	N/A	N/A	N/A
5500 - 5700	802.11a CDD Mode	covered by the worst case 802.11n 20 MHz CDD			
Power with Antenna Array Gain up to 6 dBi					
5500 - 5700	802.11n 20MHz CDD	17.30	17.14	20.23	105.46
5510 - 5670	802.11n 40MHz CDD	18.83	18.88	21.87	153.65
Power with Antenna Array Gain up to 7.21 dBi					
5500 - 5700	802.11n 20MHz CDD	16.48	16.11	19.31	85.30
5510 - 5670	802.11n 40MHz CDD	18.83	18.88	21.87	153.65

5.3. DESCRIPTION OF AVAILABLE ANTENNAS

The radio utilizes a stamped metal antenna (Hitachi, HMT05/HFT17-DL07), with a maximum gains as table below,

Band	Ant Main	Ant Aux	$10^{(Ant\ Main /10)}$	$10^{(Ant\ Aux/10)}$	$10^{(ant\ main/10)+10^{(ant\ aux/10)}}$	$10 \cdot \log[10^{(ant\ main/10)+10^{(ant\ aux/10)}}]$ (dBm)
5.15-5.25GHz	5.60	5.60	3.631	3.631	7.262	8.610
5.25-5.35GHz	5.60	5.60	3.631	3.631	7.262	8.610
5.4-5.725GHz	4.20	4.20	2.630	2.630	5.261	7.210

5.4. SOFTWARE AND FIRMWARE

The EUT driver software installed during testing was BCMWL5, rev. 4.170.63.0.

The test utility software used during testing was wl_tool, rev. 4.170 RC63.0.

5.5. WORST-CASE CONFIGURATION AND MODE

The worst-case data rate for each mode is determined to be as follows, based on preliminary tests of the chipset utilized in this radio.

All final tests in the 802.11a mode were made at 6 Mb/s.

All final tests in the 802.11n HT20 mode were made at MCS0.

All final tests in the 802.11n HT40 mode were made at MCS0.

For radiated emissions below 1 GHz the worst-case configuration is determined to be the mode and channel with the highest output power.

5.6. DESCRIPTION OF TEST SETUP

SUPPORT EQUIPMENT

PERIPHERAL SUPPORT EQUIPMENT LIST				
Description	Manufacturer	Model	Serial Number	FCC ID
Laptop	Dell	Inspiron 1526	CN-0SE2C2-70166-77L-0011	DoC
AC Adapter	Dell	HP-0Q065B83	CN-0N2765-7890-421-0063	DoC

I/O CABLES

I/O CABLE LIST						
Cable No.	Port	# of Identical Ports	Connector Type	Cable Type	Cable Length	Remarks
1	AC	1	AC	Unshielded	1.2 m	N/A
2	DC	1	DC	Unshielded	1.2 m	N/A

TEST SETUP

The EUT is installed in a host laptop computer via Express card to MiniPCI-E adapter boards during the tests. Test software exercised the radio card.

SETUP DIAGRAM FOR TESTS

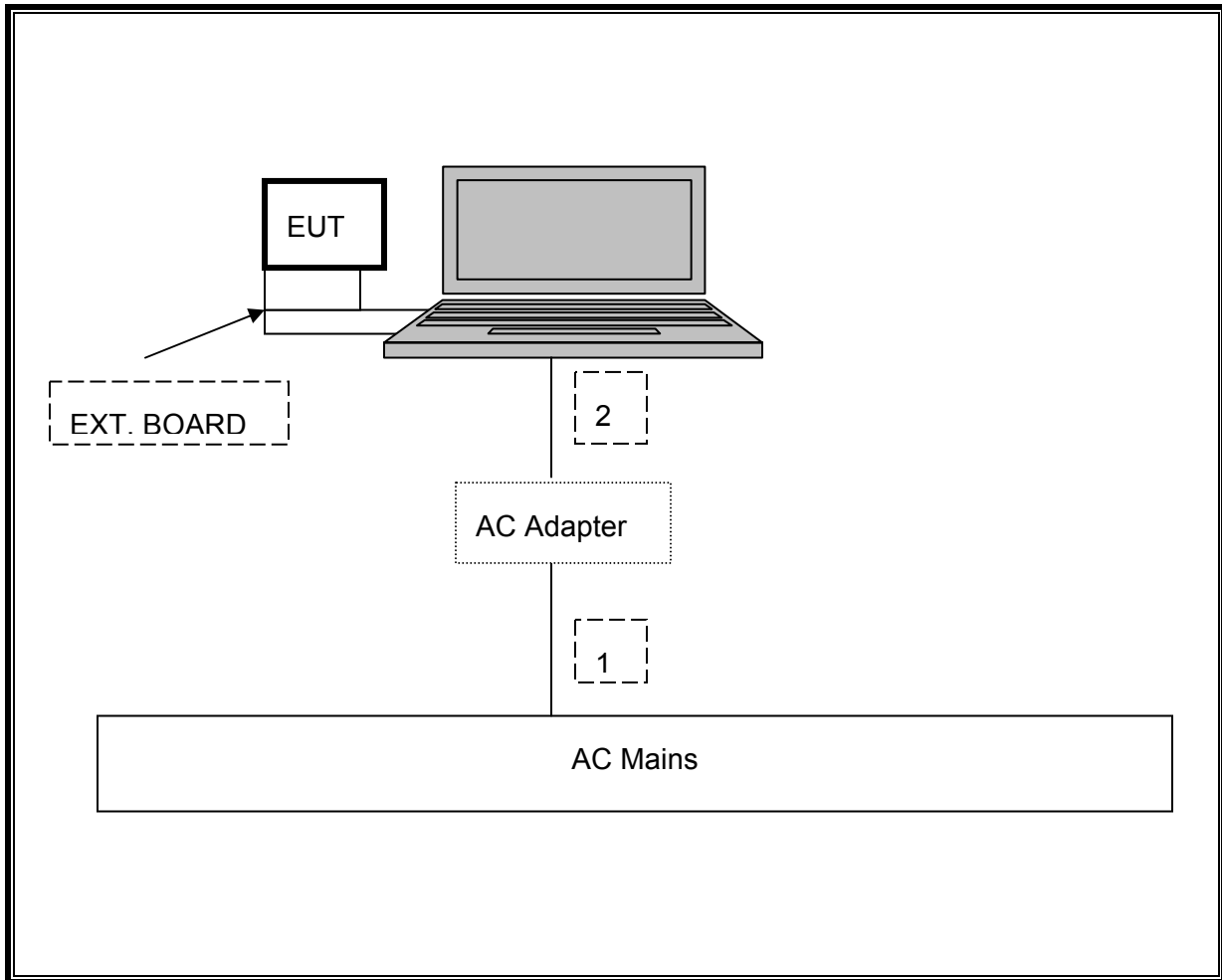

6. TEST AND MEASUREMENT EQUIPMENT

The following test and measurement equipment was utilized for the tests documented in this report:

TEST EQUIPMENT LIST					
Description	Manufacturer	Model	Asset	Cal Date	Cal Due
EMI Receiver, 2.9 GHz	Agilent / HP	8542E	C00957	2/6/2007	6/12/2008
RF Filter Section, 2.9 GHz	Agilent / HP	85420E	C00958	2/6/2007	6/12/2008
Preamplifier, 1300 MHz	Agilent / HP	8447D	C00885	5/9/2007	5/9/2008
LISN, 30 MHz	FCC	LISN-50/250-25-2	N02625	10/25/2007	10/25/2008
LISN, 10 kHz ~ 30 MHz	Solar	8012-50-R-24-BNC	N02481	10/25/2007	10/25/2008
EMI Test Receiver, 30 MHz	R & S	ESHS 20	N02396	10/16/2006	1/27/2008
Spectrum Analyzer, 44 GHz	Agilent / HP	E4446A	C01012	5/2/2006	8/7/2008
Antenna, Horn, 18 GHz	ETS	3117	C01006	4/15/2007	4/15/08
Preamplifier, 26.5 GHz	Agilent / HP	8449B	C01052	8/3/2007	8/3/08
Antenna, Bilog, 2 GHz	Sunol Sciences	JB1	C01011	10/13/2007	10/13/08
Peak Power Meter	Agilent / HP	E4416A	C00963	02/14/07	12/02/08
Peak / Average Power Sensor	Agilent	E9327A	C00964	02/14/07	12/02/08
Antenna, Horn 26 ~ 40 GHz	ARA	MWH-2640/B	C01009	4/13/2008	4/13/2008
4.0 GHz High Pass Filter	Micro Tronics	HPM13351	N/A	N/A	N/A
2.4 - 2.5 Reject Filter	Micro Tronics	BRM50702	N/A	N/A	N/A
7.6 GHz High Pass Filter	Micro Tronics	HPM13350	N/A	N/A	N/A
5.75 - 5.8 Reject Filter	Micro Tronics	BRC13192	N/A	N/A	N/A

7. ANTENNA PORT TEST RESULTS FOR THE 5.15–5.25 GHZ

7.1. 802.11a MODE

7.1.1. 26 dB and 99% BANDWIDTH

LIMITS

None; for reporting purposes only.

TEST PROCEDURE

The transmitter output is connected to the spectrum analyzer. The RBW is set to 1% to 3% of the measured bandwidth. The VBW is set to 3 times the RBW. The sweep time is coupled. The spectrum analyzer internal bandwidth function is utilized.

RESULTS

Channel	Frequency (MHz)	26 dB Bandwidth (MHz)	99% Bandwidth (MHz)
Low	5180	19.092	16.4858
Middle	5200	19.155	16.5105
High	5240	19.384	16.5475

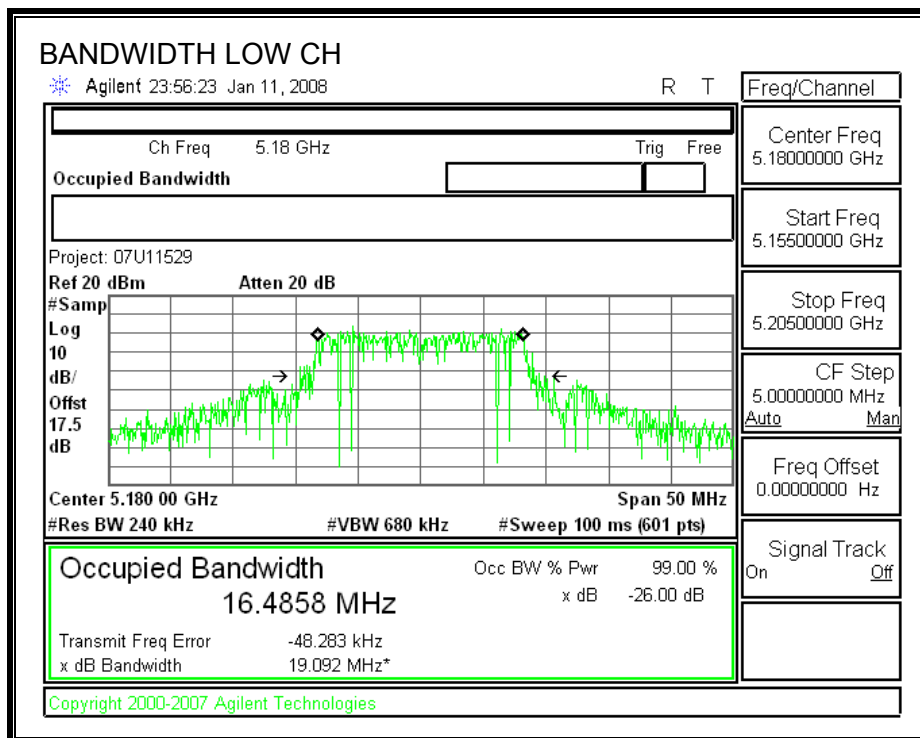

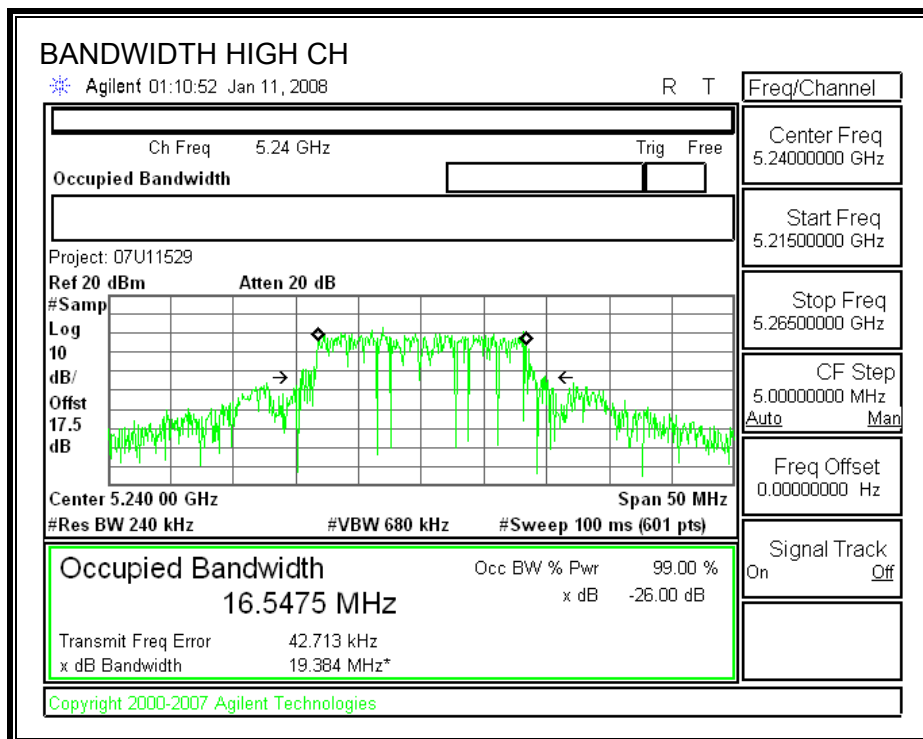
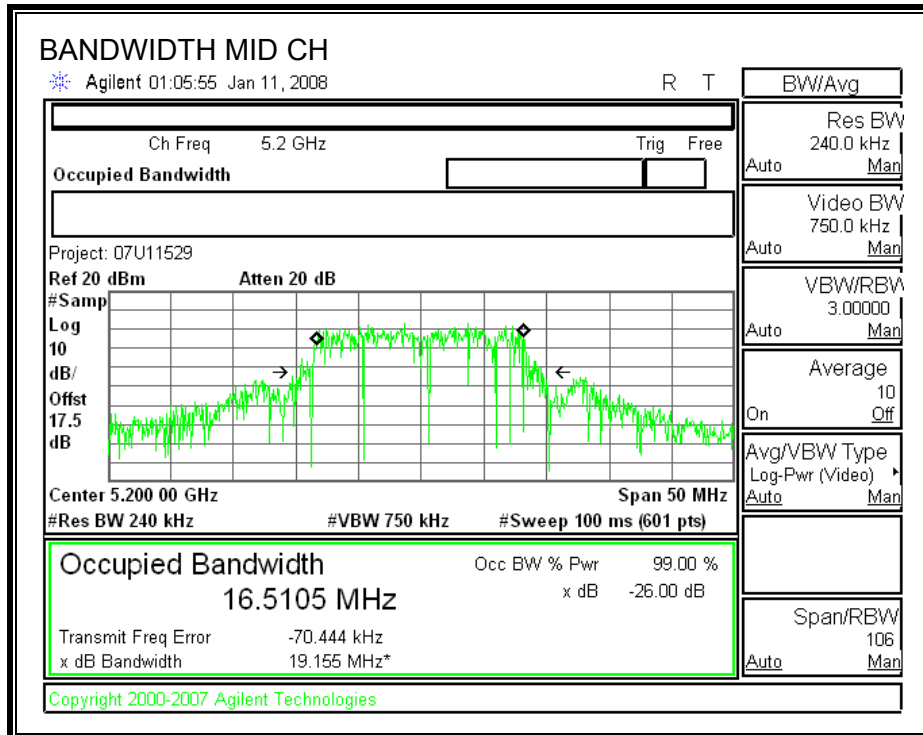

7.1.2. OUTPUT POWER

LIMITS

FCC §15.407 (a) (1) & IC RSS-210 A9.2 (1)

For the 5.15-5.25 GHz band, the maximum conducted output power over the frequency band of operation shall not exceed the lesser of 50 mW or 4 dBm + 10 log B, where B is the 26-dB emission bandwidth in MHz. If transmitting antennas of directional gain greater than 6 dBi are used, both the peak transmit power and the peak power spectral density shall be reduced by the amount in dB that the directional gain of the antenna exceeds 6 dBi.

TEST PROCEDURE

The test is performed in accordance with FCC Public Notice: APPENDIX A Guidelines for Assessing Unlicensed National Information Infrastructure (U-NII) Devices – Part 15, Subpart E, August 2002.

The transmitter output operates continuously therefore Method # 1 is used.

RESULTS

Limit

Channel	Frequency (MHz)	Fixed Limit (dBm)	B (MHz)	4 + 10 Log B Limit (dBm)	Antenna Gain (dBi)	Limit (dBm)
Low	5180	17	16.4858	16.17	5.60	16.17
Mid	5200	17	16.5105	16.18	5.60	16.18
High	5240	17	16.5475	16.19	5.60	16.19

Results

Channel	Frequency (MHz)	Power (dBm)	Limit (dBm)	Margin (dB)
Low	5180	14.33	16.17	-1.84
Mid	5200	14.13	16.18	-2.05
High	5240	14.14	16.19	-2.05

OUTPUT POWER

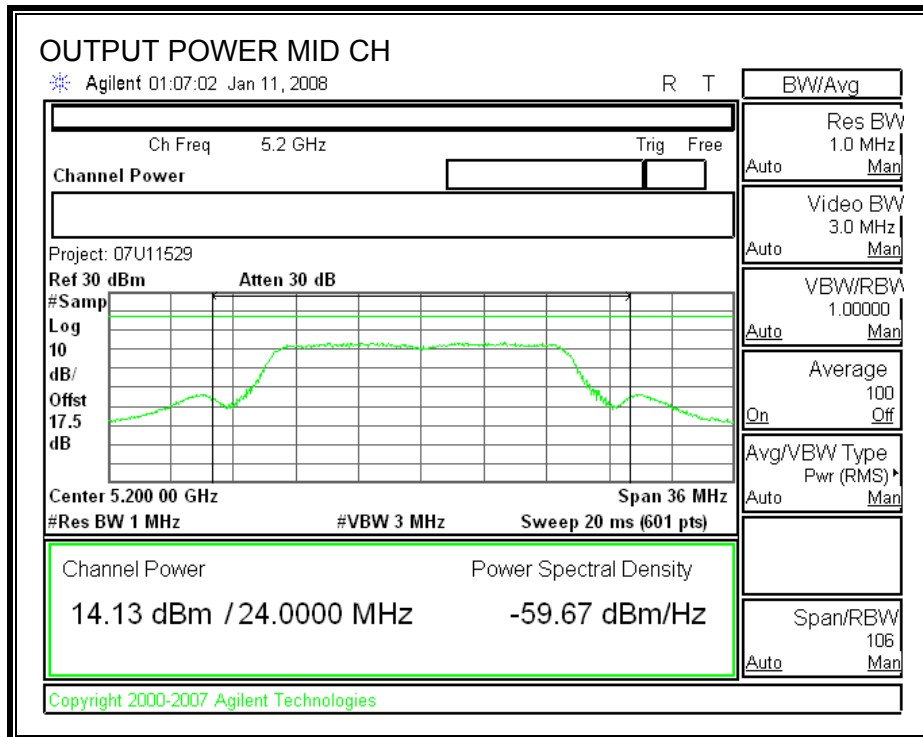
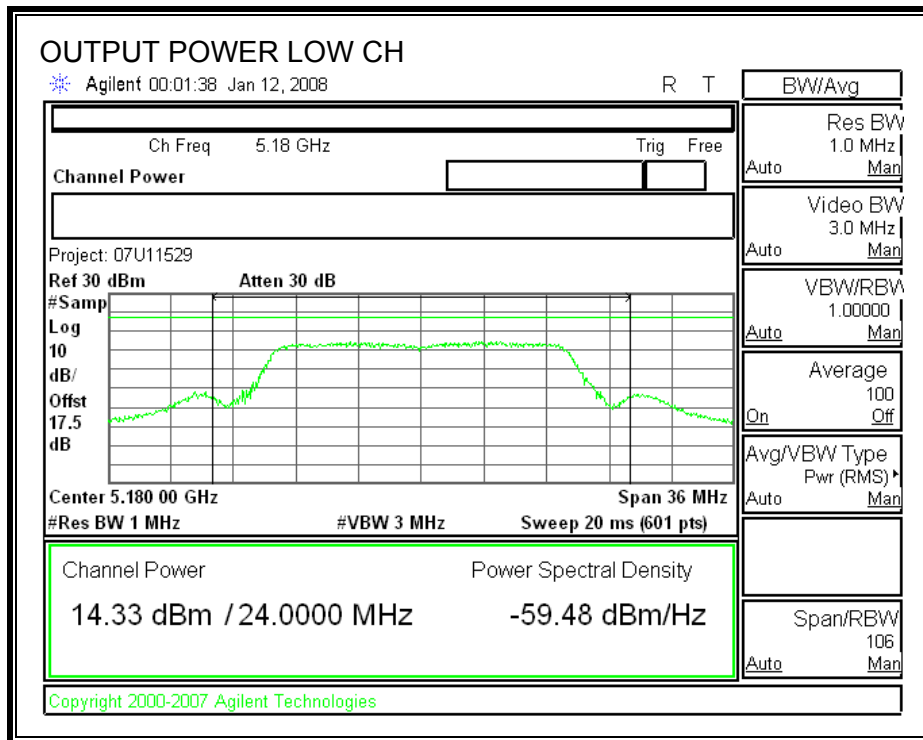

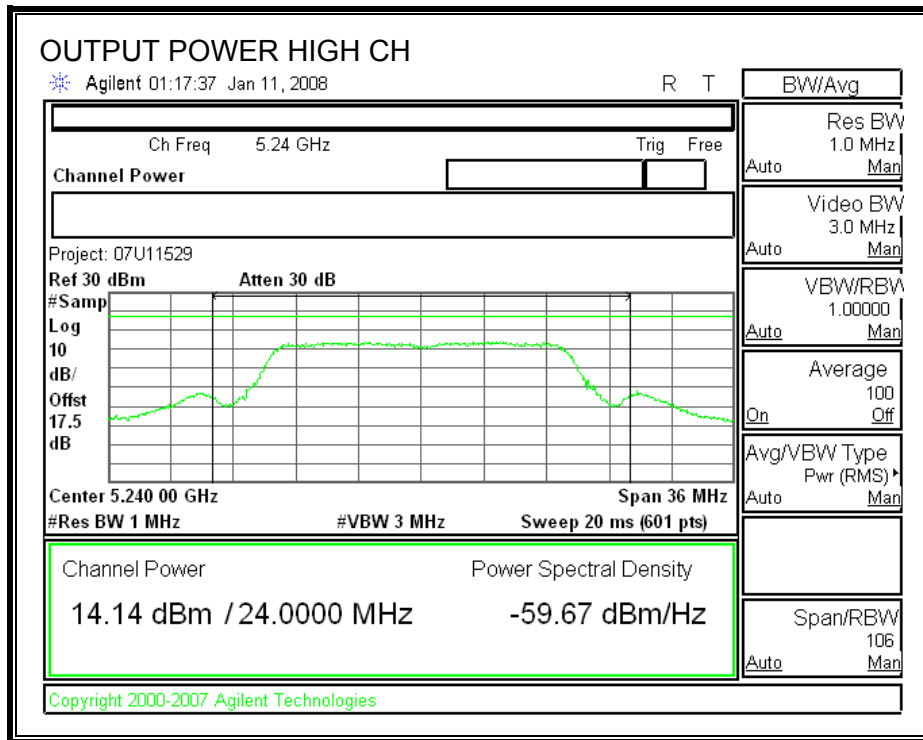

7.1.3. PEAK POWER SPECTRAL DENSITY

LIMITS

FCC §15.407 (a) (1) & IC RSS-210 A9.2 (1)

For the 5.15-5.25 GHz band, the peak power spectral density shall not exceed 4 dBm in any 1 MHz band. If transmitting antennas of directional gain greater than 6 dBi are used, both the peak transmit power and the peak power spectral density shall be reduced by the amount in dB that the directional gain of the antenna exceeds 6 dBi.

The maximum antenna gain is less than or equal to 6 dBi, therefore the limit is 4 dBm.

TEST PROCEDURE

The test is performed in accordance with FCC Public Notice: APPENDIX A Guidelines for Assessing Unlicensed National Information Infrastructure (U-NII) Devices – Part 15, Subpart E, August 2002. PPSD method #2 was used.

RESULTS

Channel	Frequency (MHz)	PPSD (dBm)	Limit (dBm)	Margin (dB)
Low	5180	3.881	4	-0.12
Middle	5200	3.228	4	-0.77
High	5240	3.775	4	-0.23

POWER SPECTRAL DENSITY

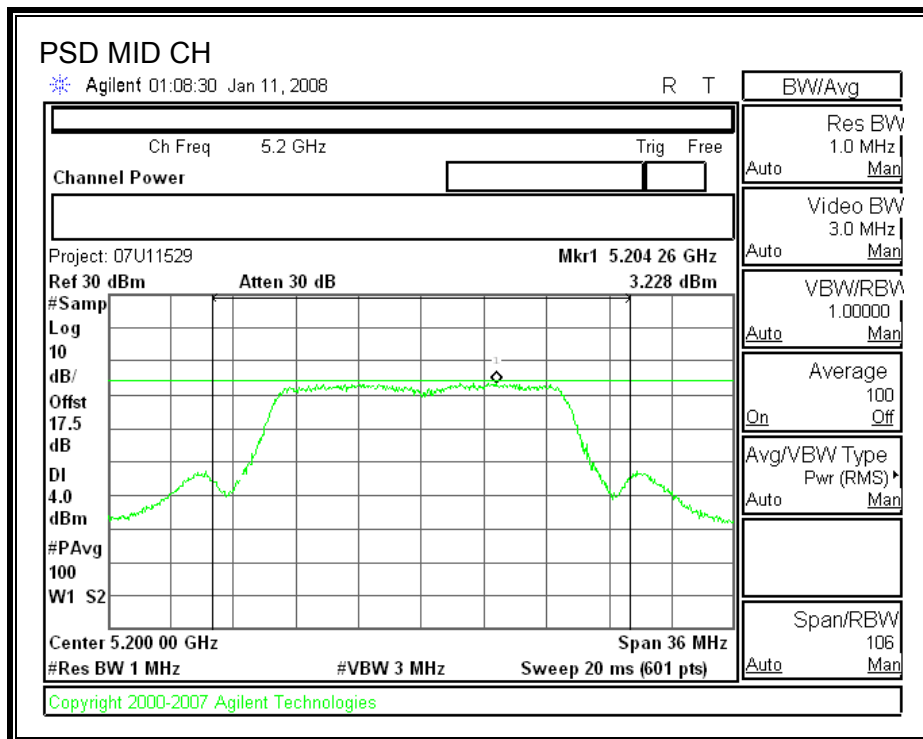
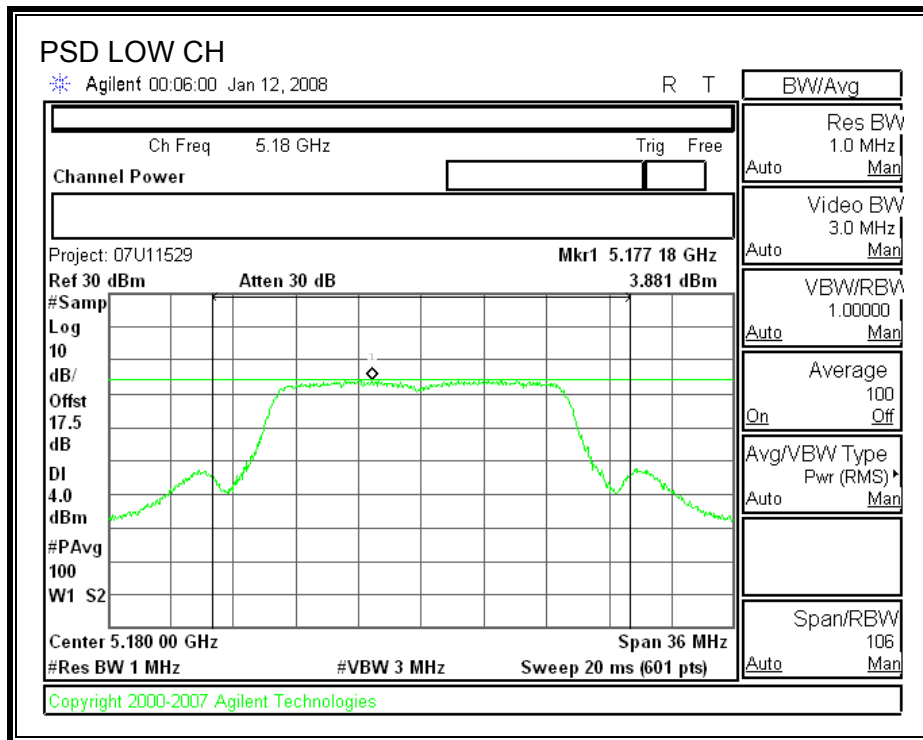

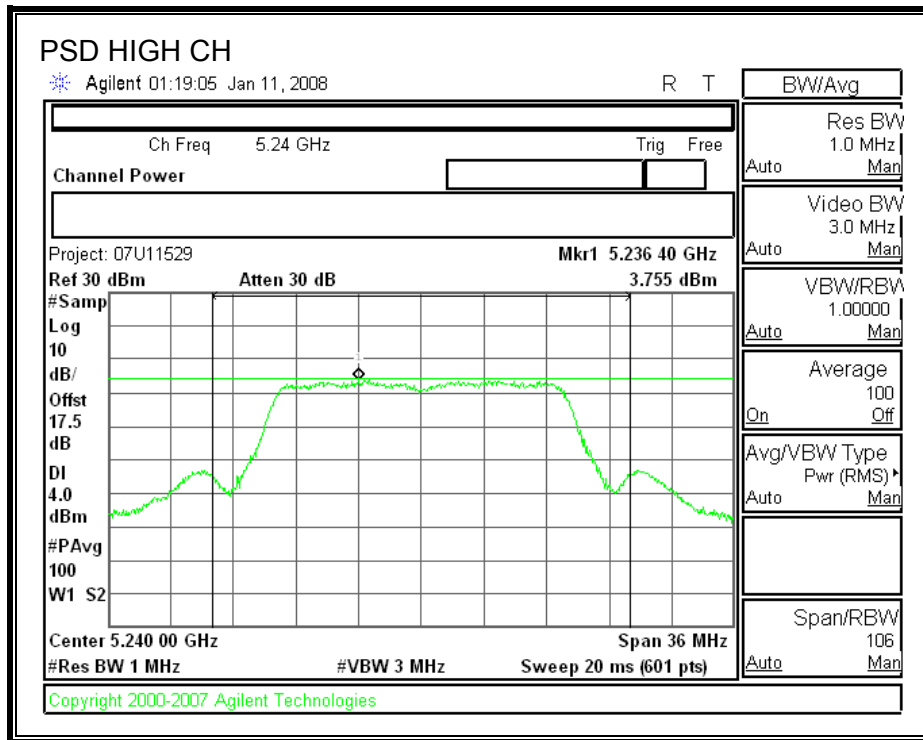

7.1.4. PEAK EXCURSION

LIMITS

FCC §15.407 (a) (6)

The ratio of the peak excursion of the modulation envelope (measured using a peak hold function) to the peak transmit power (measured as specified above) shall not exceed 13 dB across any 1 MHz bandwidth or the emission bandwidth whichever is less.

TEST PROCEDURE

The test is performed in accordance with FCC Public Notice: APPENDIX A Guidelines for Assessing Unlicensed National Information Infrastructure (U-NII) Devices – Part 15, Subpart E, August 2002.

Since Method # 1 was used for peak power measurements, Method # 1 settings are used for the second PPSD trace.

RESULTS

Channel	Frequency (MHz)	Peak Excursion (dB)	Limit (dB)	Margin (dB)
Low	5180	9.97	13	-3.03
Middle	5200	10.46	13	-2.54
High	5240	9.11	13	-3.89

PEAK EXCURSION

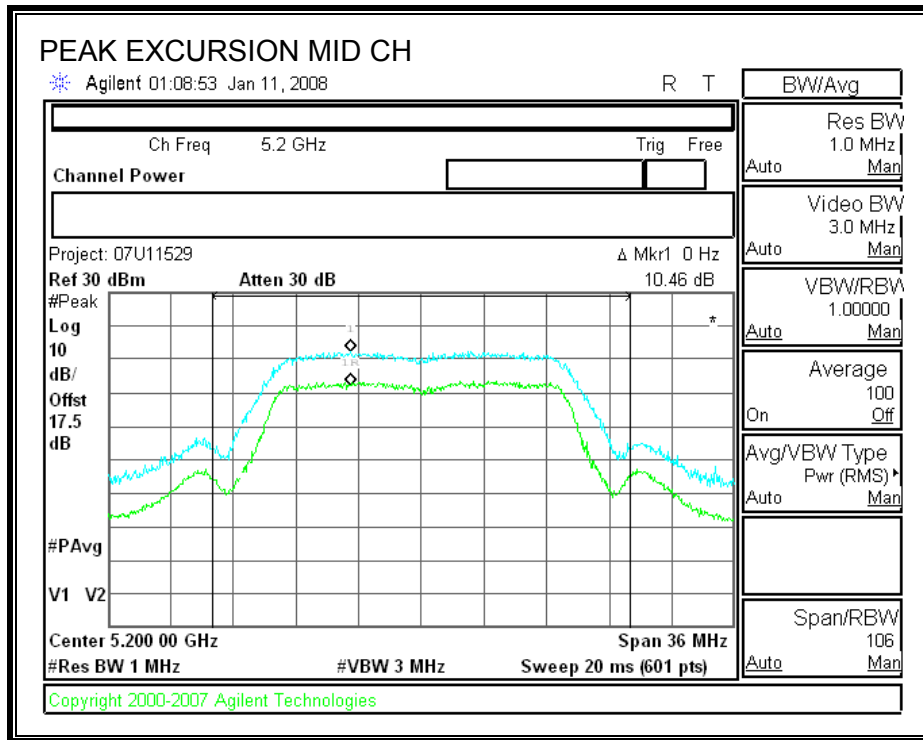
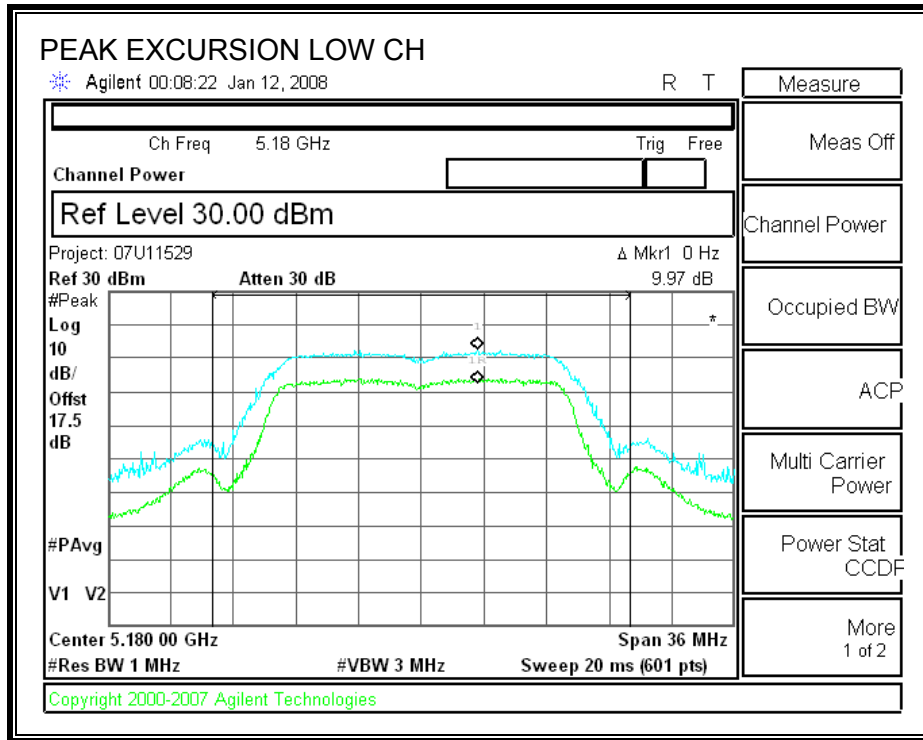

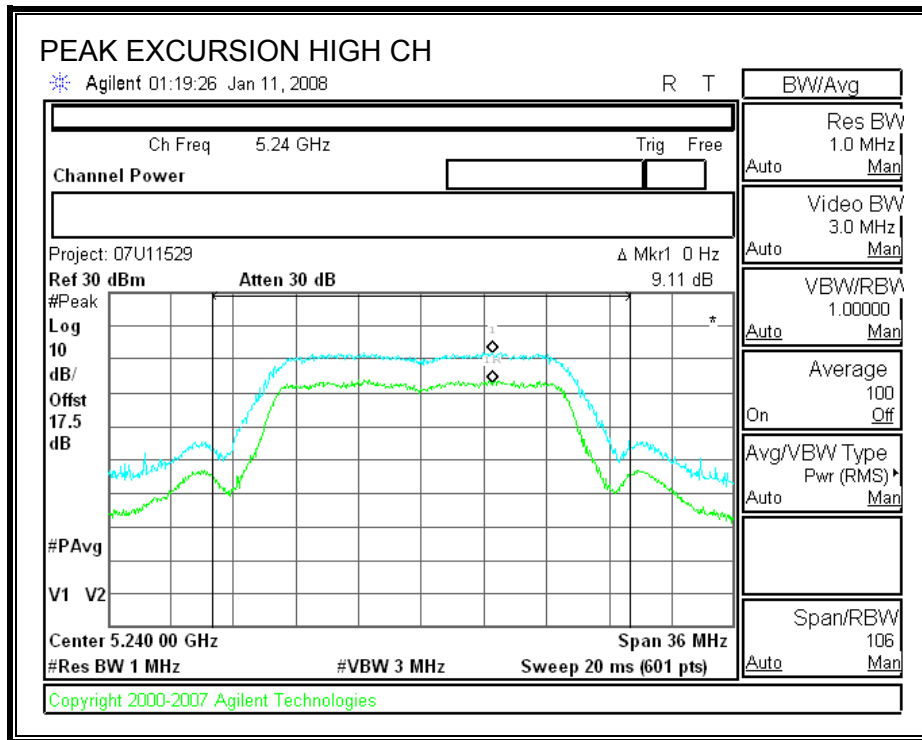

7.1.5. CONDUCTED SPURIOUS EMISSIONS

LIMITS

FCC §15.407 (b) (1) & IC RSS-210 A9.3 (1)

For transmitters operating in the 5.15-5.25 GHz band: all emissions outside of the 5.15-5.35 GHz band shall not exceed an EIRP of -27 dBm / MHz.

Limit line = -27 - EUT Antenna Gain

TEST PROCEDURE

Conducted RF measurements of the transmitter output are made to confirm that the EUT antenna port conducted emissions meet the specified limit and to identify any spurious signals that require further investigation or measurements on the radiated emissions site.

The transmitter output is connected to the spectrum analyzer. The resolution bandwidth is set to 1 MHz. The video bandwidth is set to 1 MHz. Peak detection measurements are compared to the average EIRP limit, adjusted for the maximum antenna gain. If necessary, additional average detection measurements are made.

Measurements are made over the 30 MHz to 40 GHz range with the transmitter set to the lowest, middle, and highest channels.

RESULTS

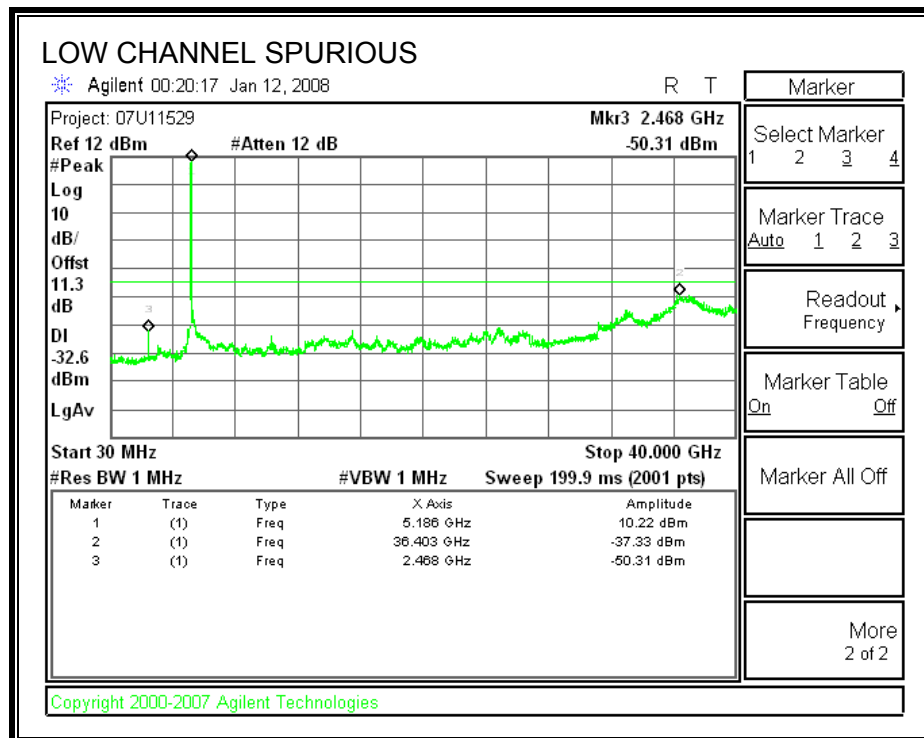

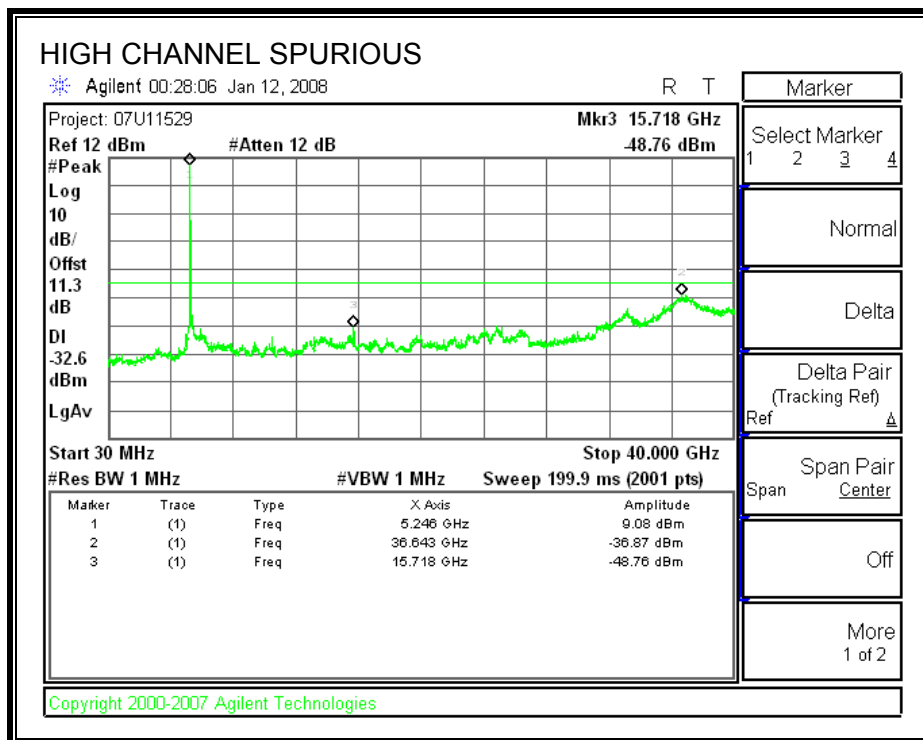
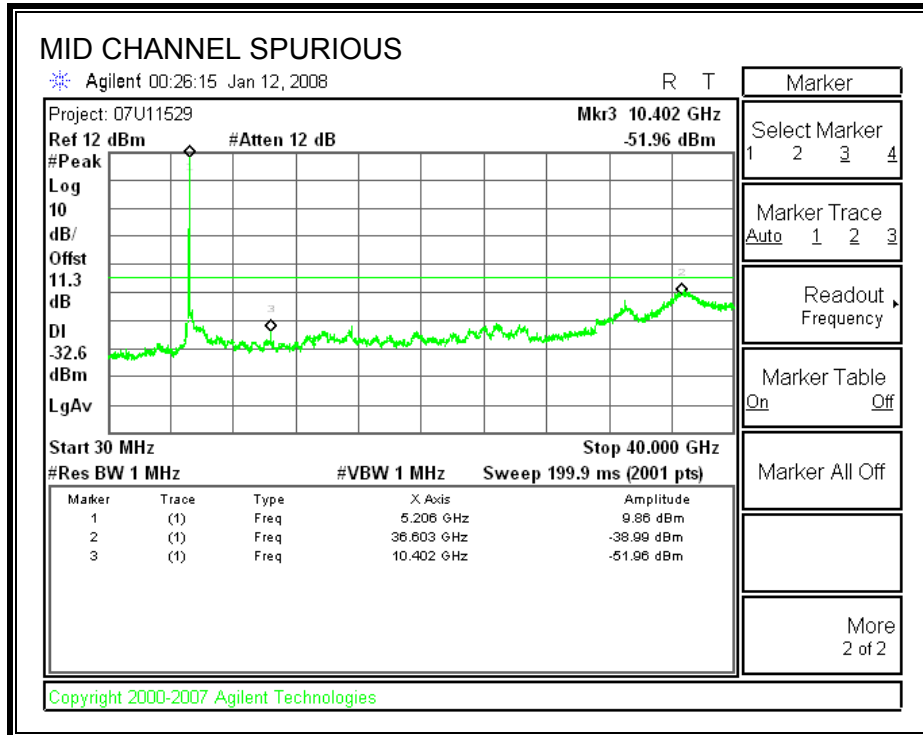

7.2. 802.11n HT20 MODE

7.2.1. 26 dB and 99% BANDWIDTH

LIMITS

None; for reporting purposes only.

TEST PROCEDURE

The transmitter outputs are connected to the spectrum analyzer. The RBW is set to 1% to 3% of the measured bandwidth. The VBW is set to 3 times the RBW. The sweep time is coupled. The spectrum analyzer internal bandwidth function is utilized.

RESULTS

Channel	Frequency (MHz)	26 dB Bandwidth (MHz)	99% Bandwidth (MHz)
Low	5180	19.744	17.4872
Middle	5200	19.406	17.6707
High	5240	19.335	16.4073

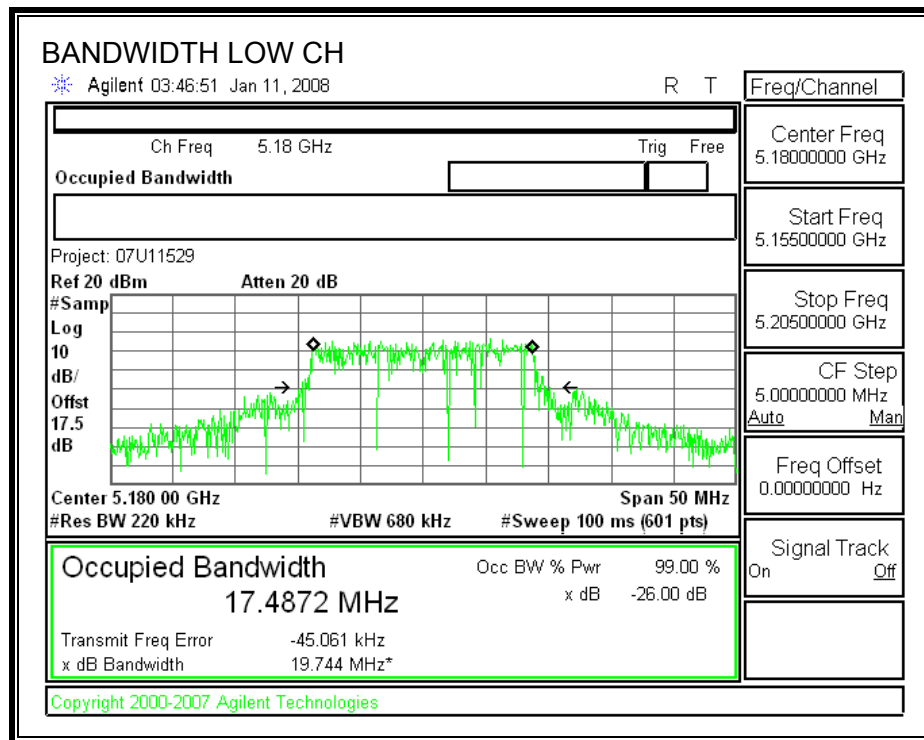

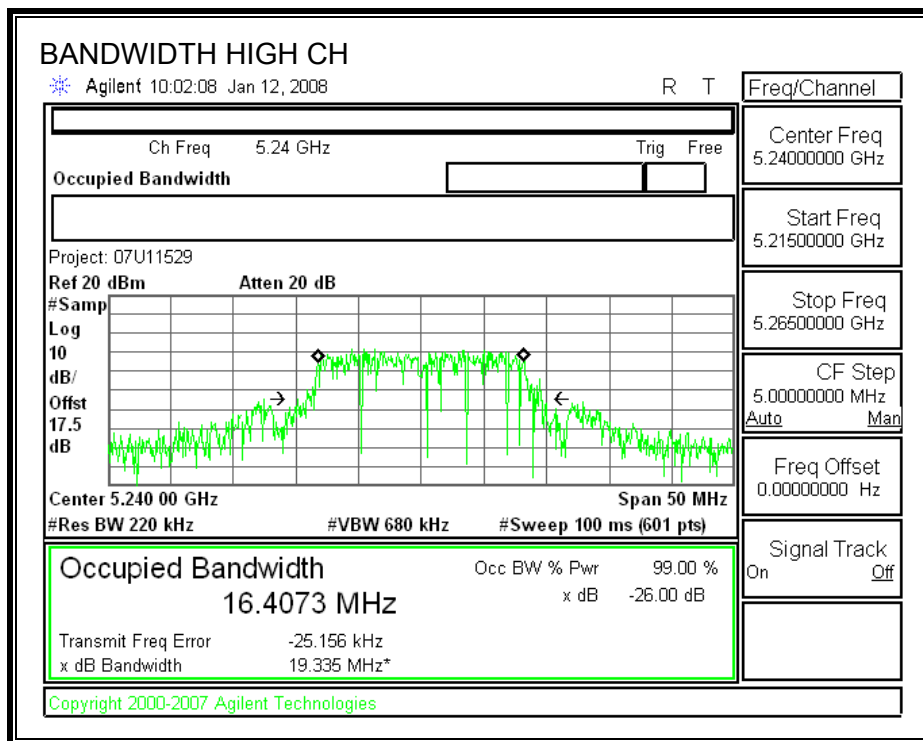
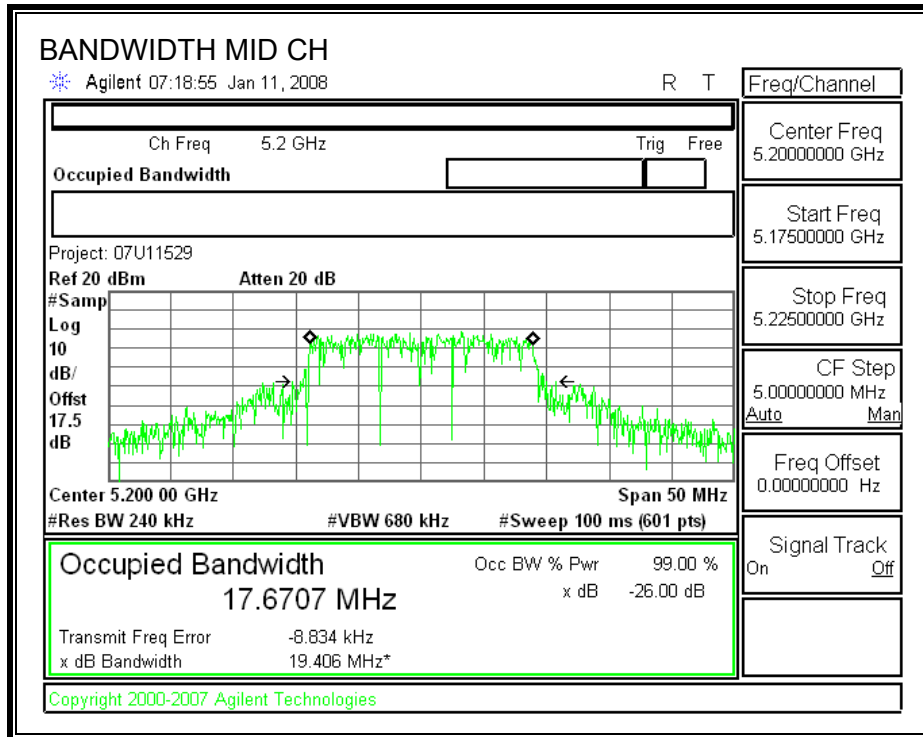

7.2.2. OUTPUT POWER

LIMITS

FCC §15.407 (a) (1)

IC RSS-210 A9.2 (1)

For the 5.15-5.25 GHz band, the maximum conducted output power over the frequency band of operation shall not exceed the lesser of 50 mW or 4 dBm + 10 log B, where B is the 26-dB emission bandwidth in MHz. If transmitting antennas of directional gain greater than 6 dBi are used, both the peak transmit power and the peak power spectral density shall be reduced by the amount in dB that the directional gain of the antenna exceeds 6 dBi.

TEST PROCEDURE

The test is performed in accordance with FCC Public Notice: APPENDIX A Guidelines for Assessing Unlicensed National Information Infrastructure (U-NII) Devices – Part 15, Subpart E, August 2002.

The transmitter output operates continuously therefore Method # 1 is used.

RESULTS

6 dBi Antenna Gain

Limit

Channel	Frequency (MHz)	Fixed Limit (dBm)	B (MHz)	4 + 10 Log B Limit (dBm)	Antenna Gain (dBi)	Limit (dBm)
Low	5180	17	19.744	16.95	6.00	16.95
Mid	5200	17	19.406	16.88	6.00	16.88
High	5240	17	19.335	16.86	6.00	16.86

Individual Chain Results

Channel	Frequency (MHz)	Chain 0 Power (dBm)	Chain 1 Power (dBm)	Total Power (dBm)	Limit (dBm)	Margin (dB)
Low	5180	10.20	10.14	13.18	16.95	-3.77
Mid	5200	10.16	10.06	13.12	16.88	-3.76
High	5240	10.14	10.13	13.15	16.86	-3.72

8.61 dBi Antenna Gain

Limit

Channel	Frequency (MHz)	Fixed Limit (dBm)	B (MHz)	4 + 10 Log B Limit (dBm)	Antenna Gain (dBi)	Limit (dBm)
Low	5180	17	19.744	16.95	8.61	14.34
Mid	5200	17	19.406	16.88	8.61	14.27
High	5240	17	19.335	16.86	8.61	14.25

Individual Chain Results

Channel	Frequency (MHz)	Chain 1 Power (dBm)	Chain 2 Power (dBm)	Total Power (dBm)	Limit (dBm)	Margin (dB)
Low	5180	8.35	8.14	11.26	14.34	-5.99
Mid	5200	8.24	8.16	11.21	14.27	-6.03
High	5240	8.20	8.13	11.18	14.25	-6.05

CHAIN 0 OUTPUT POWER With 6 dBi antenna gain

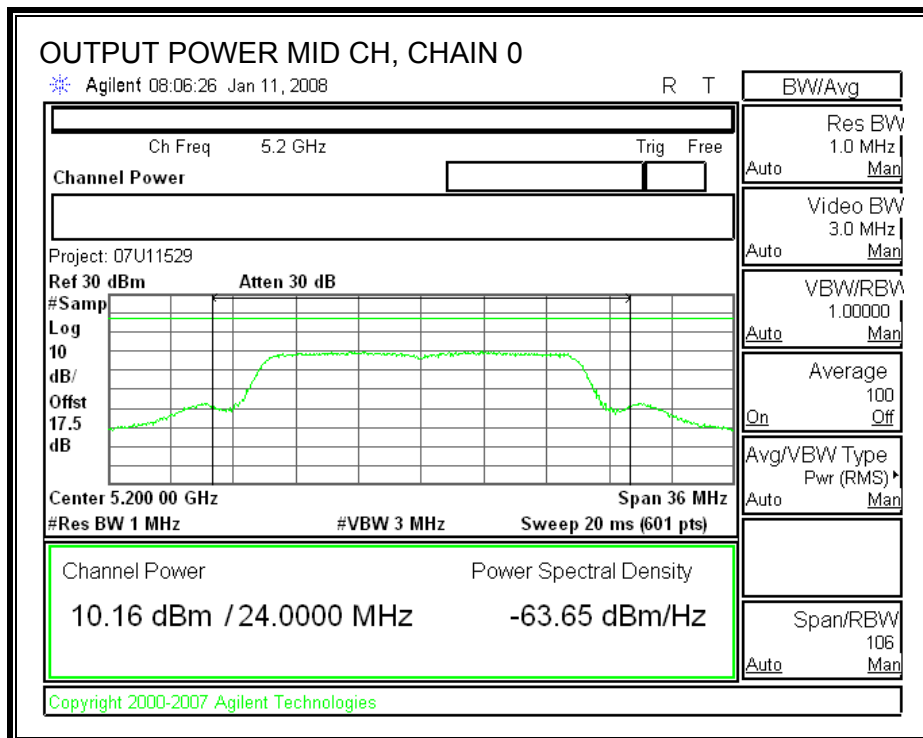
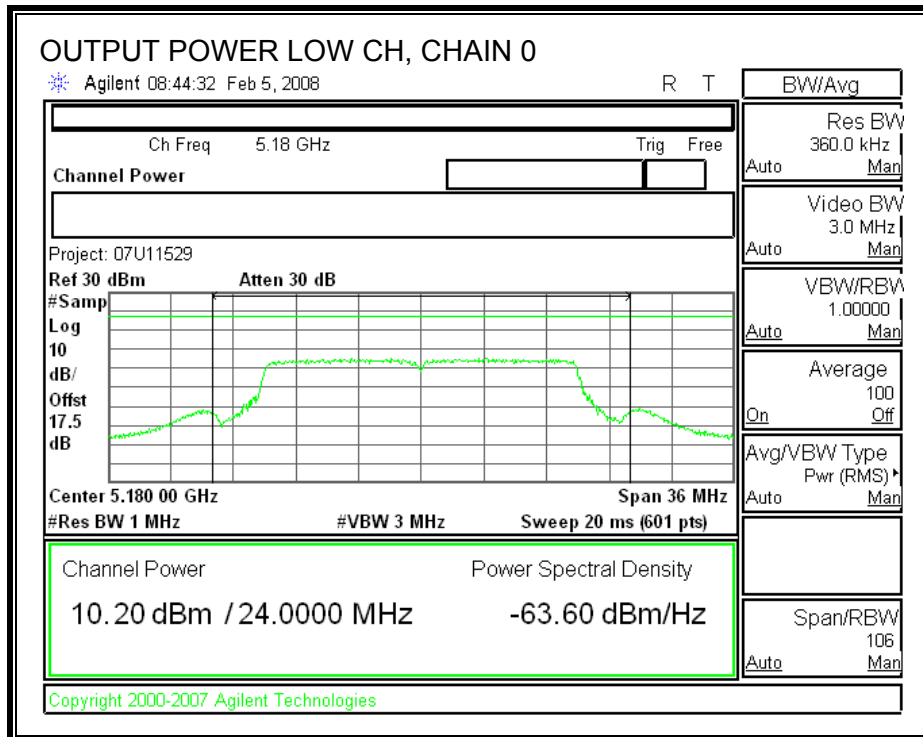

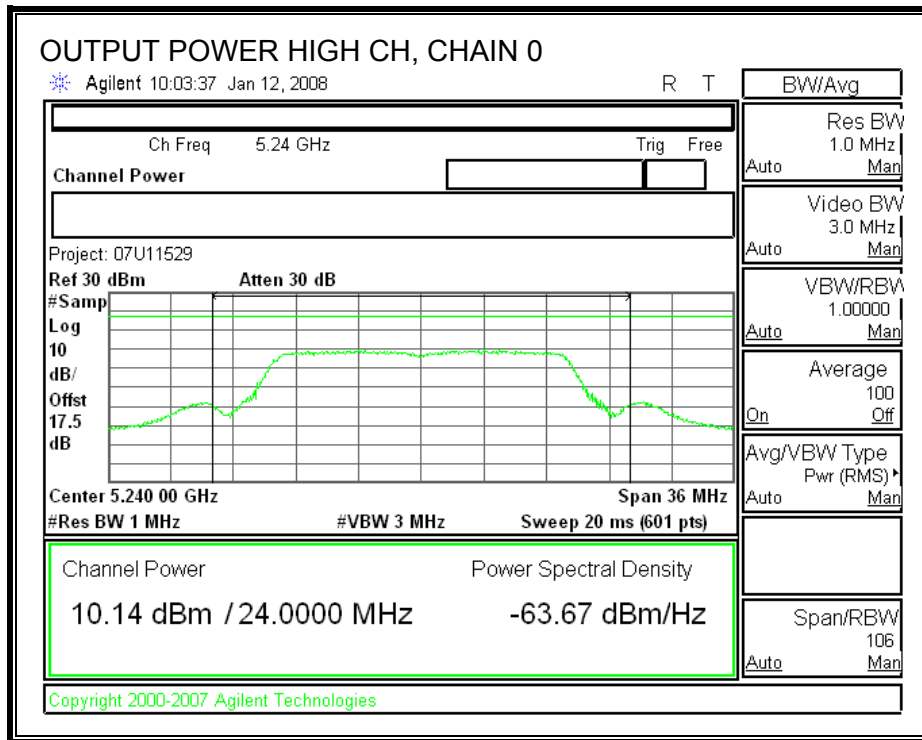

CHAIN 1 OUTPUT POWER with 6 dBi Antenna Gain

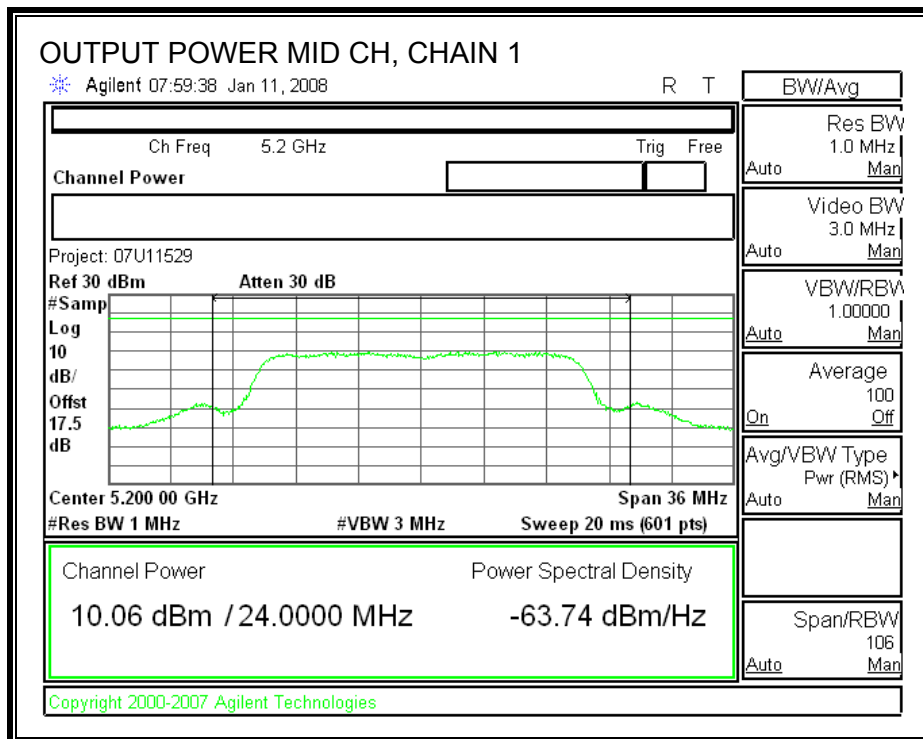
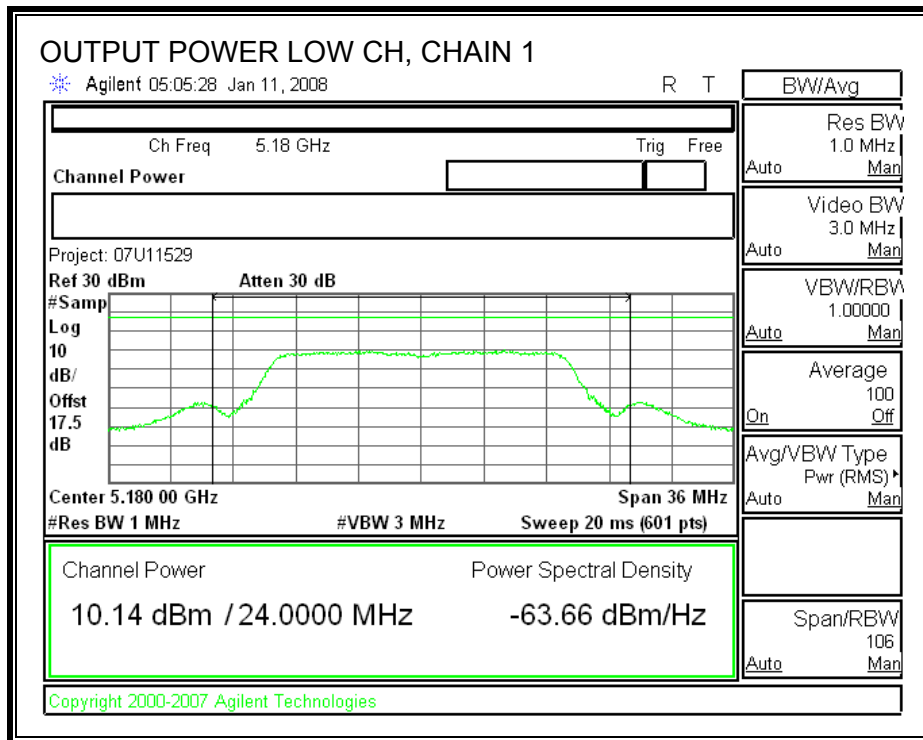

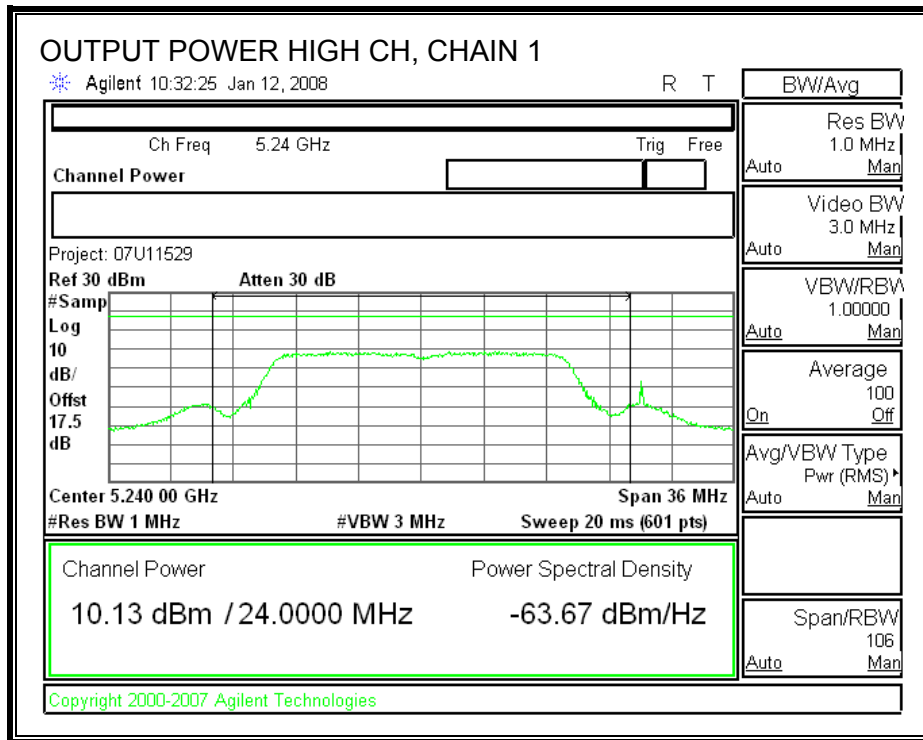

CHAIN 0 OUTPUT POWER with 8.61 dBi Antenna Gain

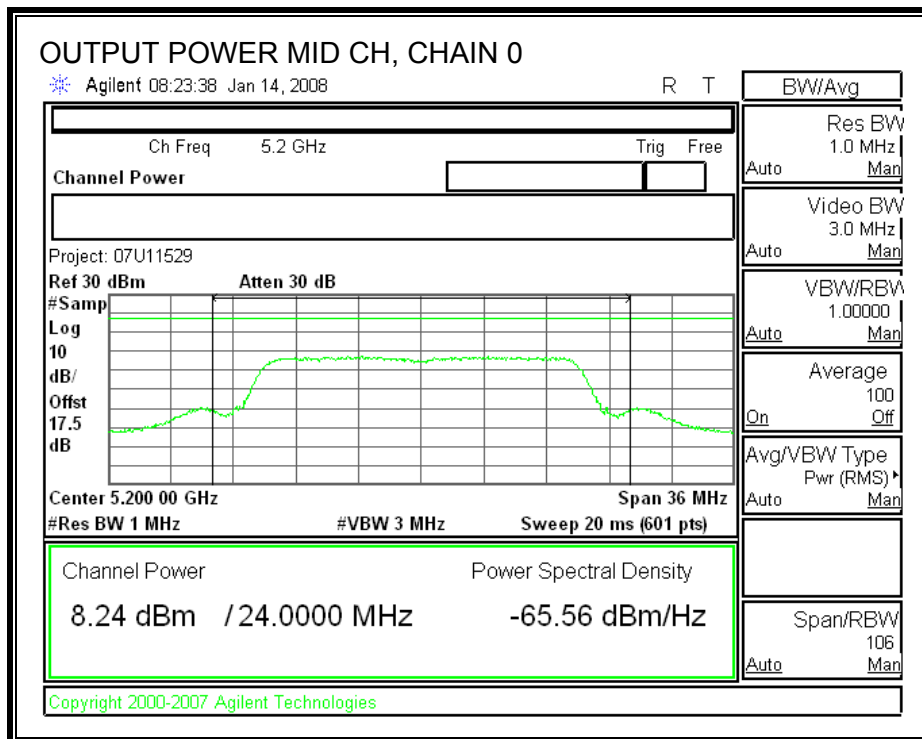
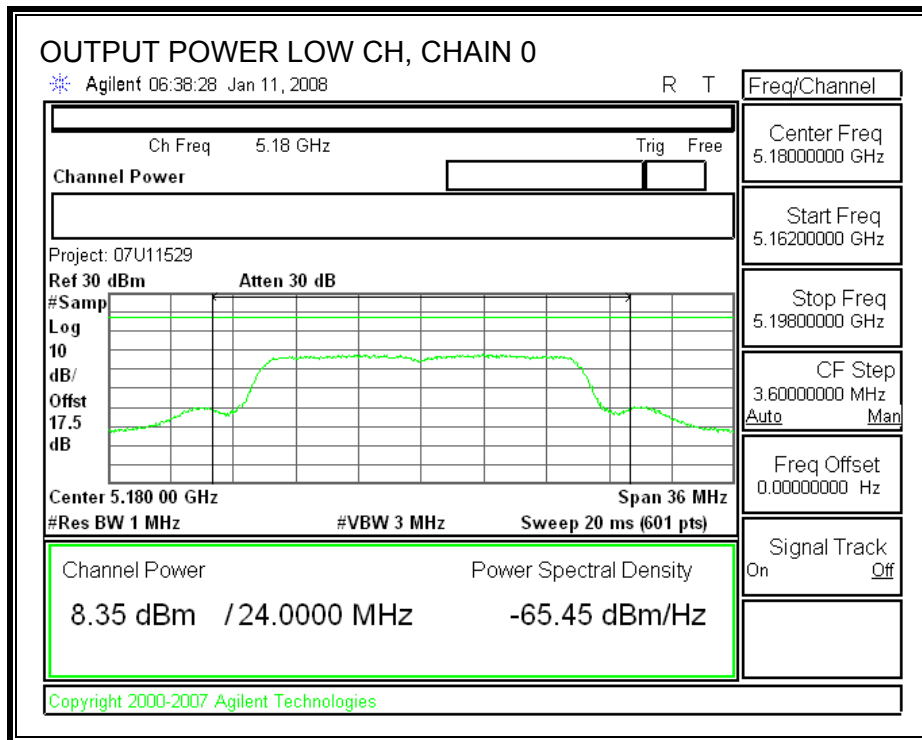

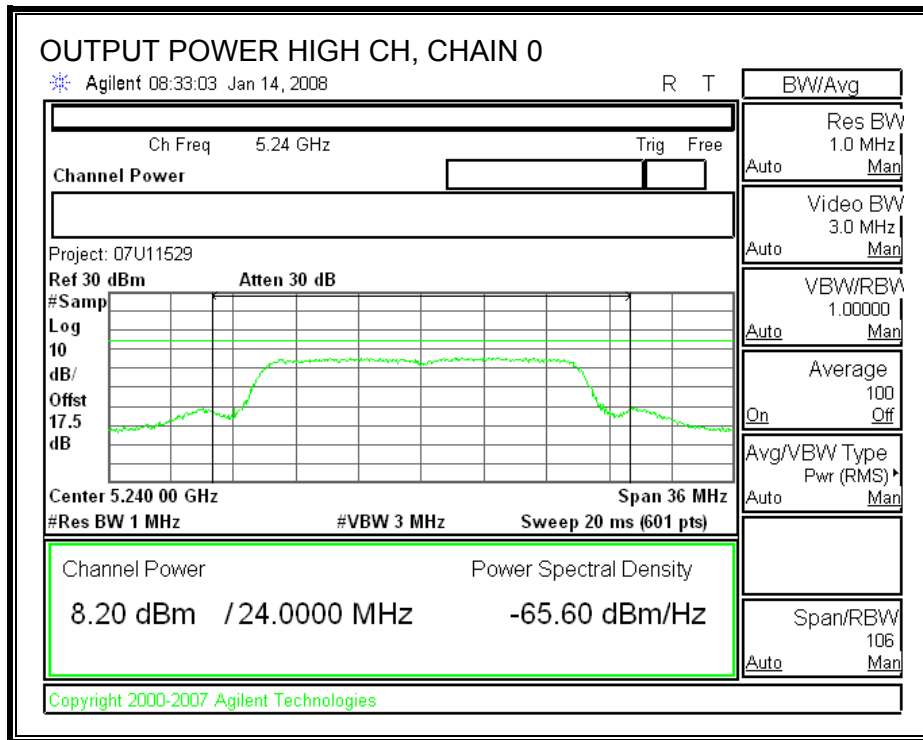

CHAIN 1 OUTPUT POWER with 8.61 dBi Antenna Gain

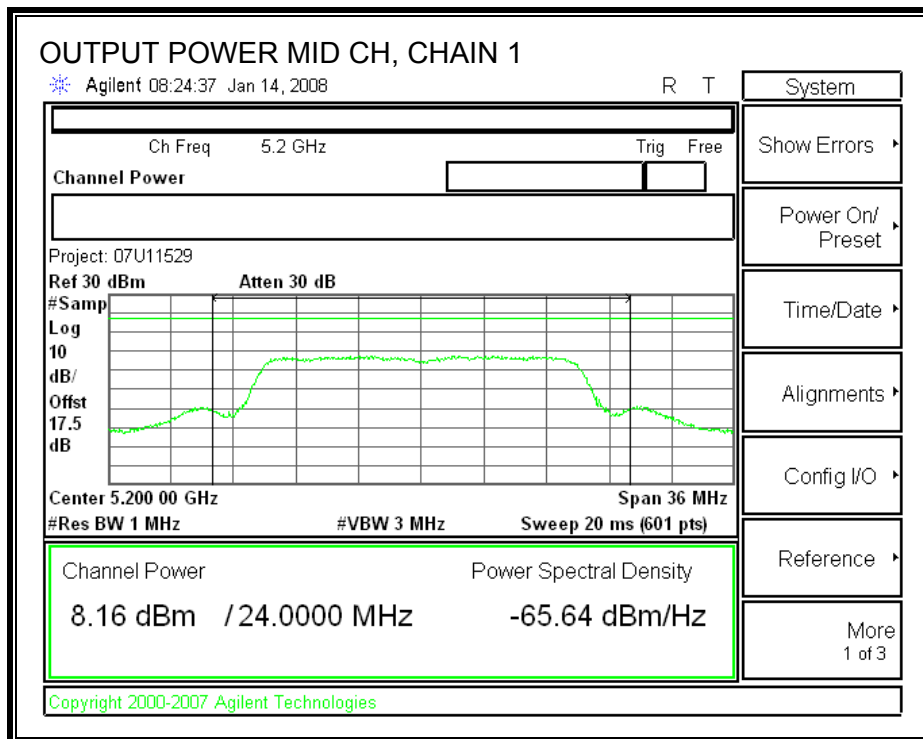
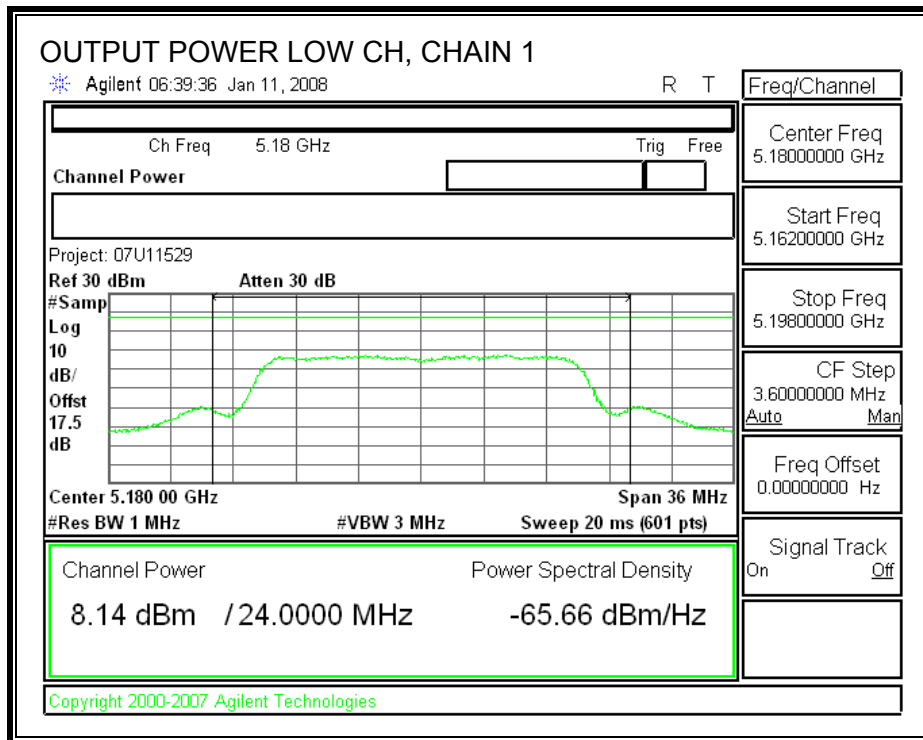

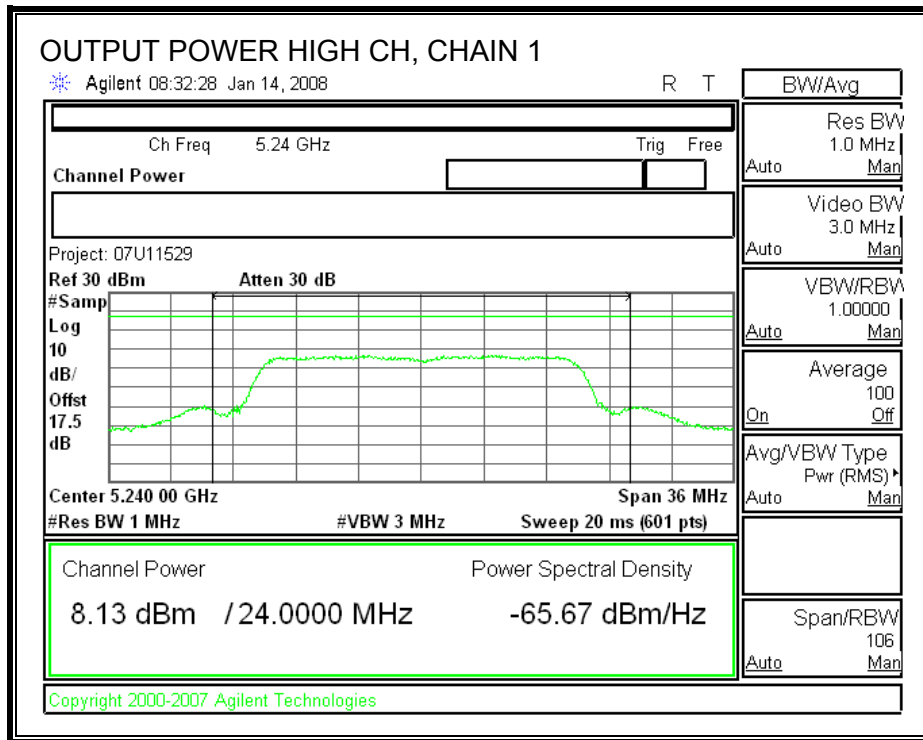

7.2.3. PEAK POWER SPECTRAL DENSITY

LIMITS

FCC §15.407 (a) (1)

IC RSS-210 A9.2 (1)

For the 5.15-5.25 GHz band, the peak power spectral density shall not exceed 4 dBm in any 1 MHz band. If transmitting antennas of directional gain greater than 6 dBi are used, both the peak transmit power and the peak power spectral density shall be reduced by the amount in dB that the directional gain of the antenna exceeds 6 dBi.

The maximum antenna gain is less than or equal to 6 dBi, therefore the limit is 4 dBm.

The maximum antenna gain is 8.61 dBi, therefore the limit is 1.39 dBm.

TEST PROCEDURE

The test is performed in accordance with FCC Public Notice: APPENDIX A Guidelines for Assessing Unlicensed National Information Infrastructure (U-NII) Devices – Part 15, Subpart E, August 2002. PPSD method #2 was used.

RESULTS (COMBINER IS WORST-CASE)

6dBi Antenna Gain

Channel	Frequency (MHz)	PPSD With Combiner (dBm)	Limit (dBm)	Margin (dB)
Low	5180	3.456	4.00	-0.54
Middle	5200	3.820	4.00	-0.18
High	5240	3.668	4.00	-0.33

8.61dBi Antenna Gain

Channel	Frequency (MHz)	PPSD With Combiner (dBm)	Limit (dBm)	Margin (dB)
Low	5180	1.243	1.39	-0.15
Middle	5200	1.223	1.39	-0.17
High	5240	1.245	1.39	-0.15

POWER SPECTRAL DENSITY WITH COMBINER (With 6 dBi Antenna Gain)

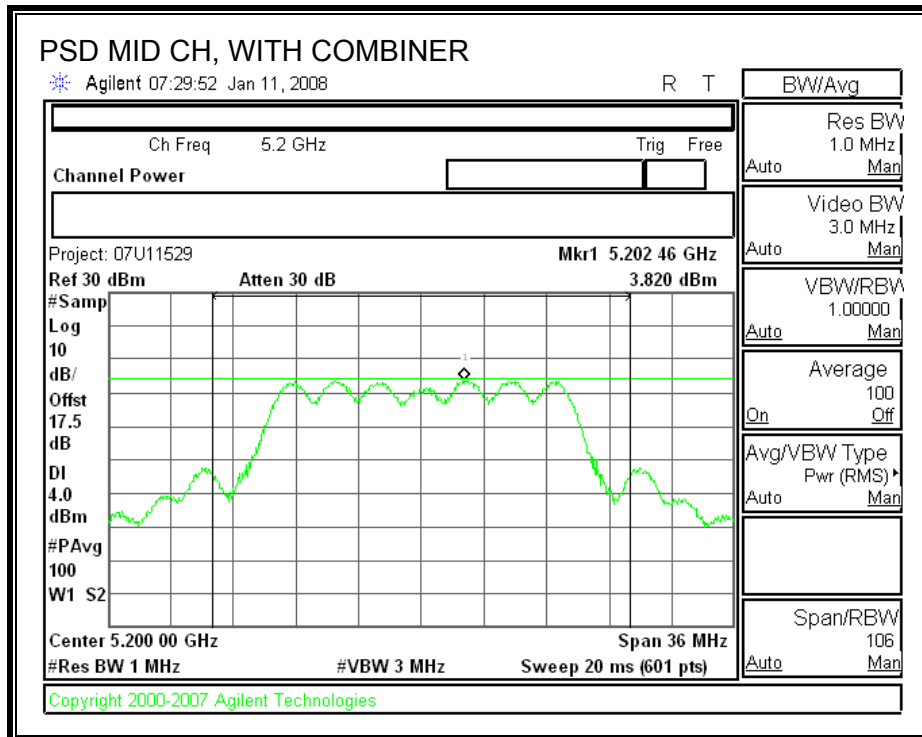
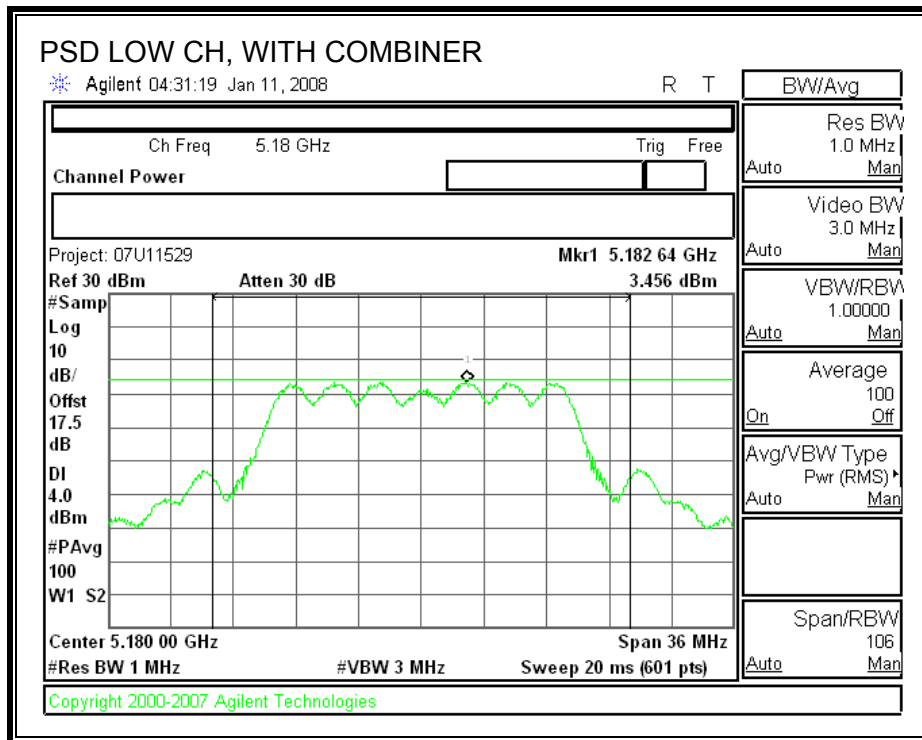

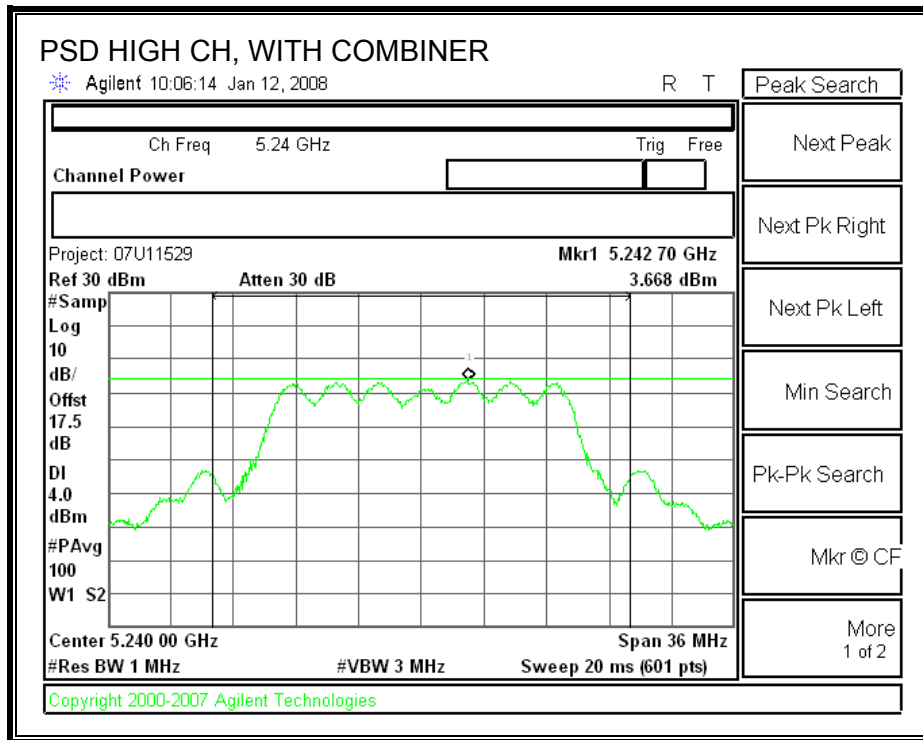

POWER SPECTRAL DENSITY WITH COMBINER (With 8.61 dBi Antenna Gain)

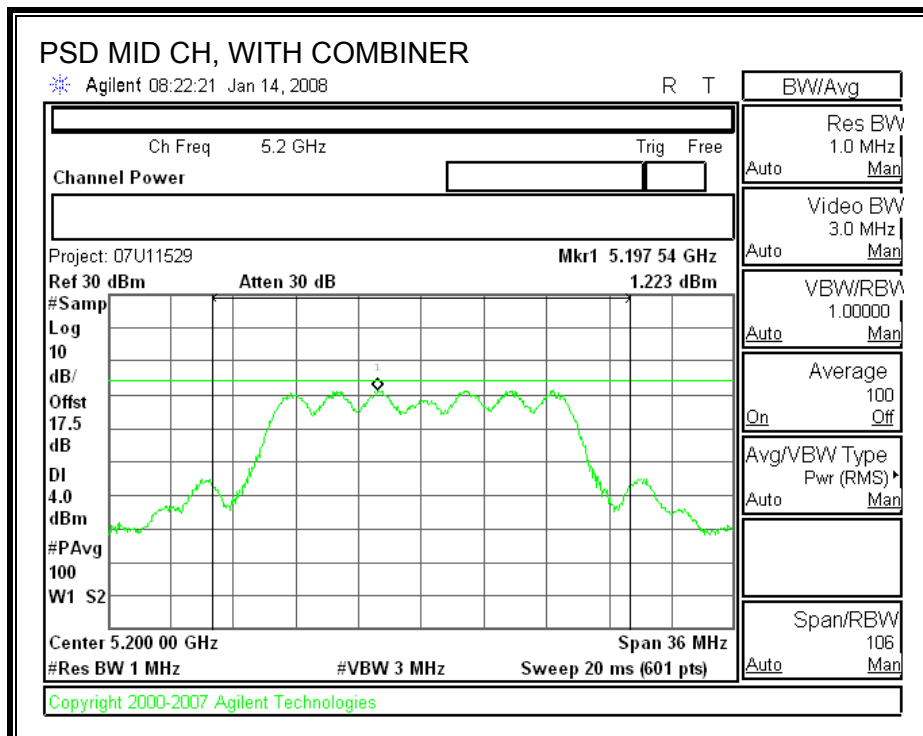
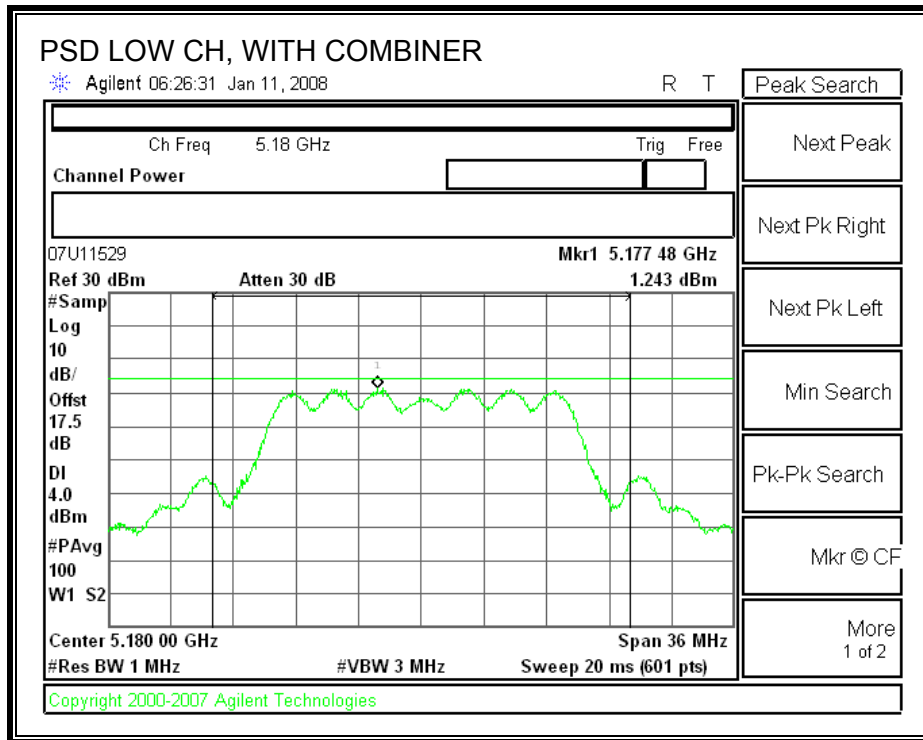

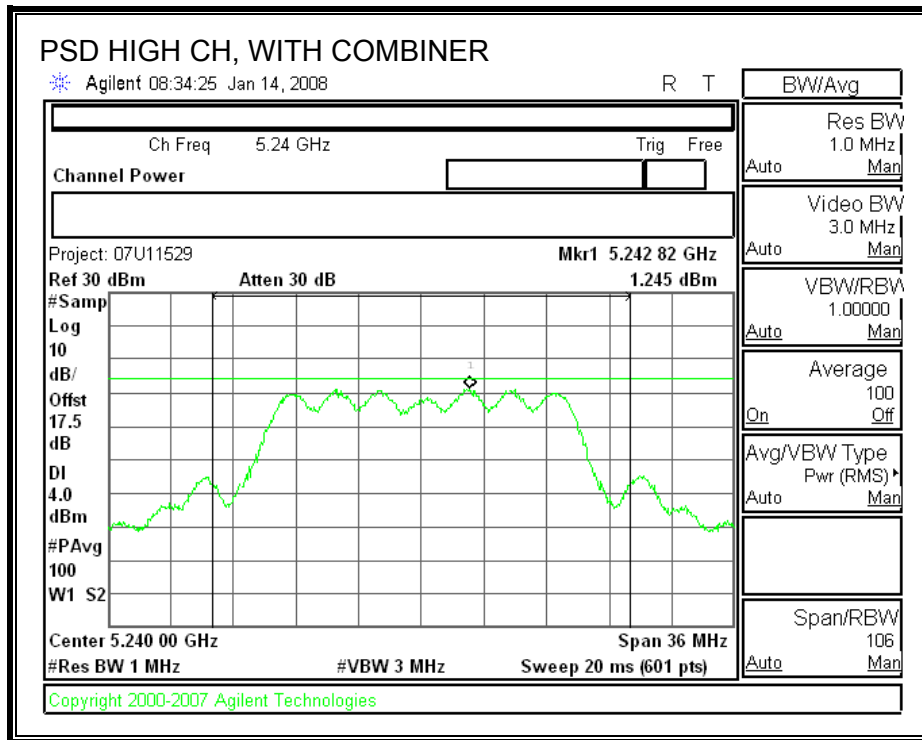

7.2.4. PEAK EXCURSION

LIMITS

FCC §15.407 (a) (6)

The ratio of the peak excursion of the modulation envelope (measured using a peak hold function) to the peak transmit power (measured as specified above) shall not exceed 13 dB across any 1 MHz bandwidth or the emission bandwidth whichever is less.

TEST PROCEDURE

The transmitter outputs are connected to the spectrum analyzer.

The test is performed in accordance with FCC Public Notice: APPENDIX A Guidelines for Assessing Unlicensed National Information Infrastructure (U-NII) Devices – Part 15, Subpart E, August 2002.

Since Method # 1 was used for peak power measurements, Method # 1 settings are used for the second PPSD trace.

RESULTS

Chain 1

Channel	Frequency (MHz)	Peak Excursion (dB)	Limit (dB)	Margin (dB)
Low	5180	8.97	13	-4.03
Middle	5200	8.30	13	-4.70
High	5240	9.33	13	-3.67

Chain 2

Channel	Frequency (MHz)	Peak Excursion (dB)	Limit (dB)	Margin (dB)
Low	5180	9.96	13	-3.04
Middle	5200	10.12	13	-2.88
High	5240	10.52	13	-2.48

PEAK EXCURSION (CHAIN 0)

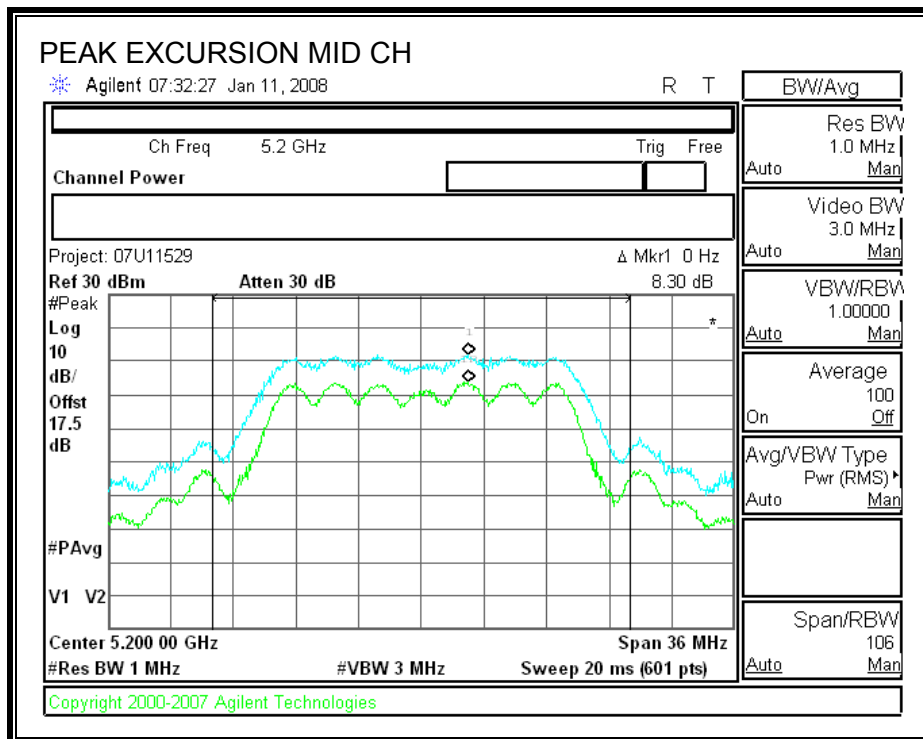
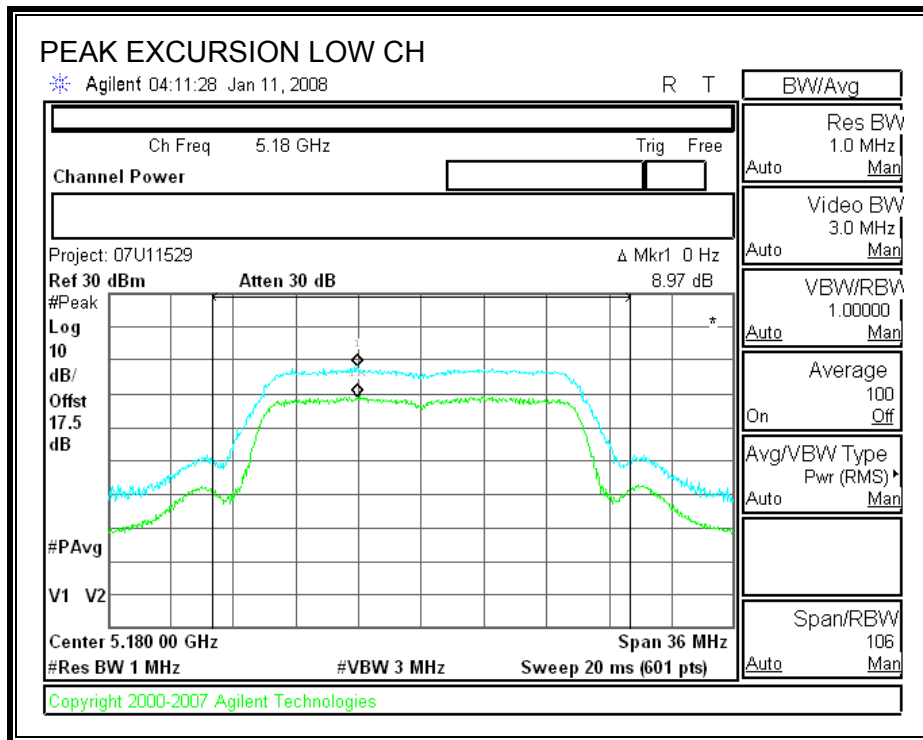

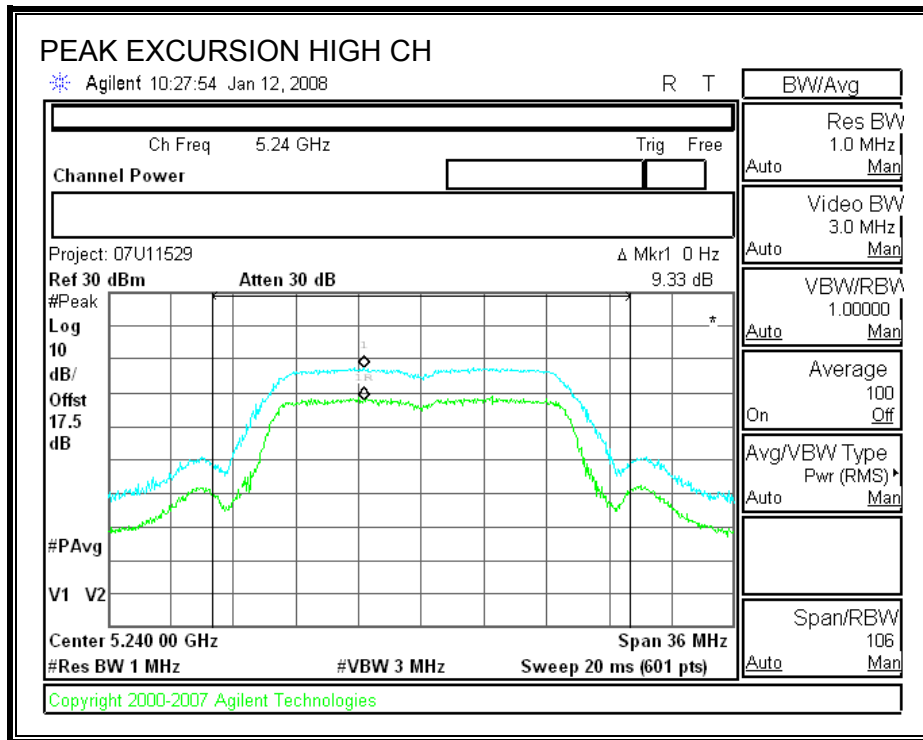

PEAK EXCURSION (CHAIN 1)

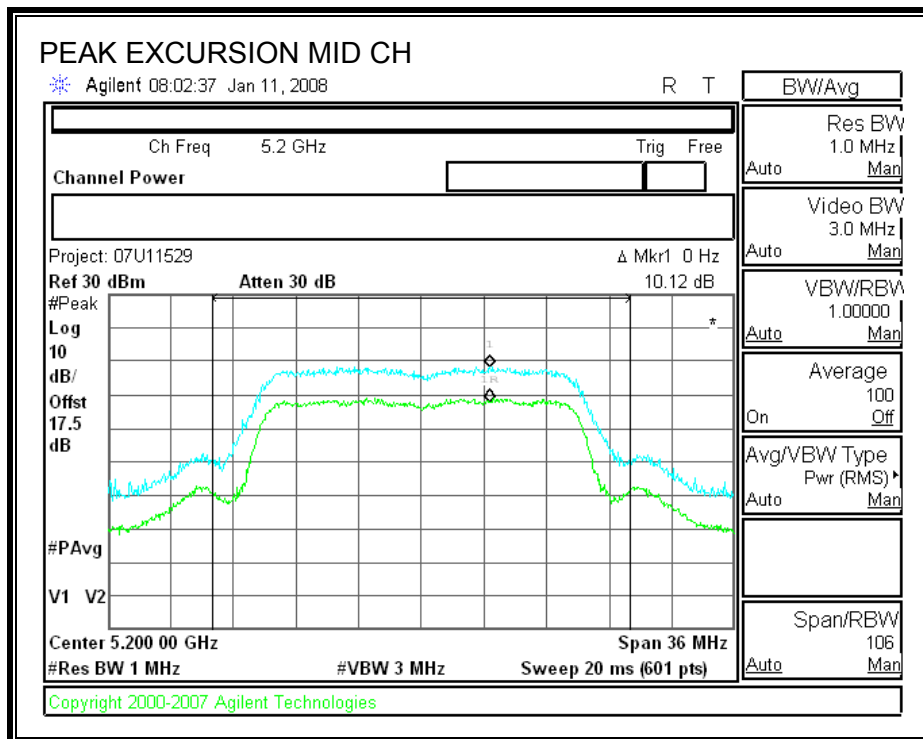
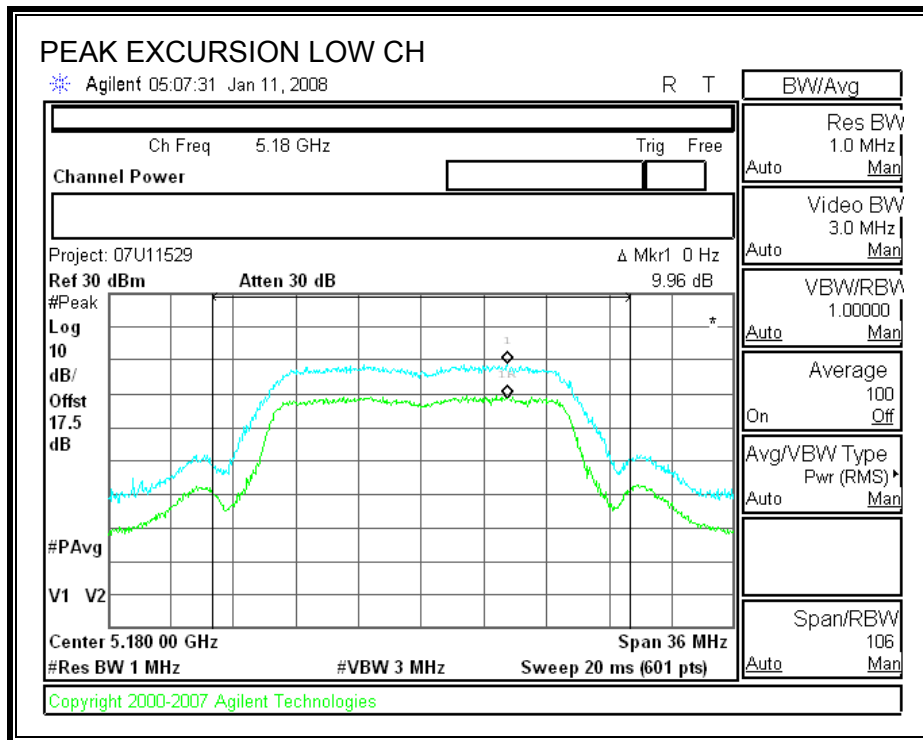

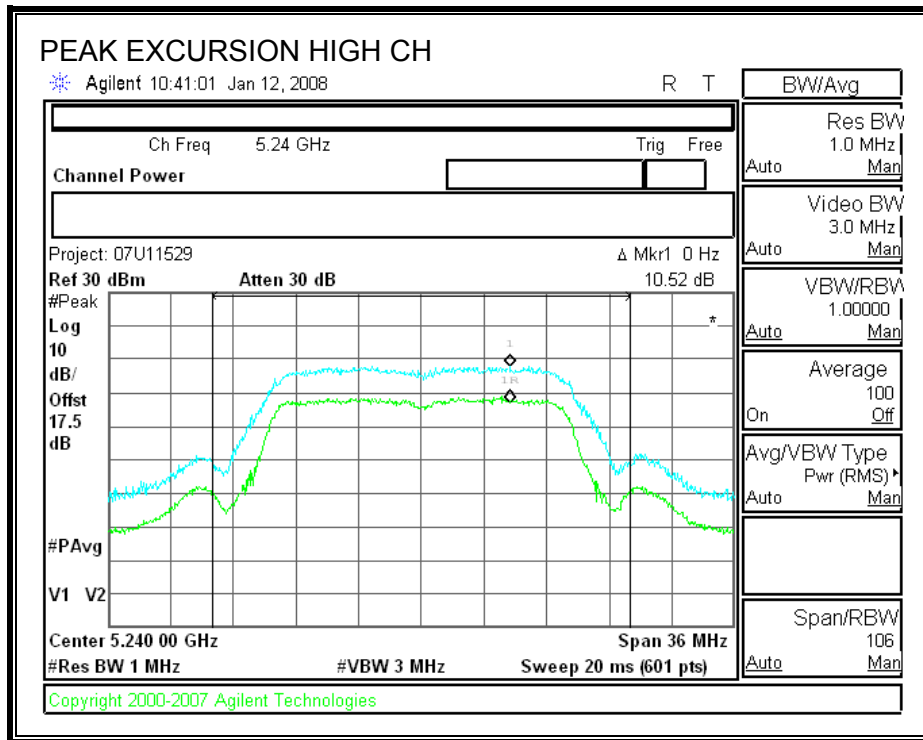

7.2.5. CONDUCTED SPURIOUS EMISSIONS

LIMITS

FCC §15.407 (b) (1)

IC RSS-210 A9.3 (1)

For transmitters operating in the 5.15-5.25 GHz band: all emissions outside of the 5.15-5.35 GHz band shall not exceed an EIRP of -27 dBm / MHz.

Limit line = -27 - EUT Antenna Gain

TEST PROCEDURE

Conducted RF measurements of the transmitter output are made to confirm that the EUT antenna port conducted emissions meet the specified limit and to identify any spurious signals that require further investigation or measurements on the radiated emissions site.

The transmitter output is connected to the spectrum analyzer. The resolution bandwidth is set to 1 MHz. The video bandwidth is set to 1 MHz. Peak detection measurements are compared to the average EIRP limit, adjusted for the maximum antenna gain. If necessary, additional average detection measurements are made.

Measurements are made over the 30 MHz to 40 GHz range with the transmitter set to the lowest, middle, and highest channels.

RESULTS

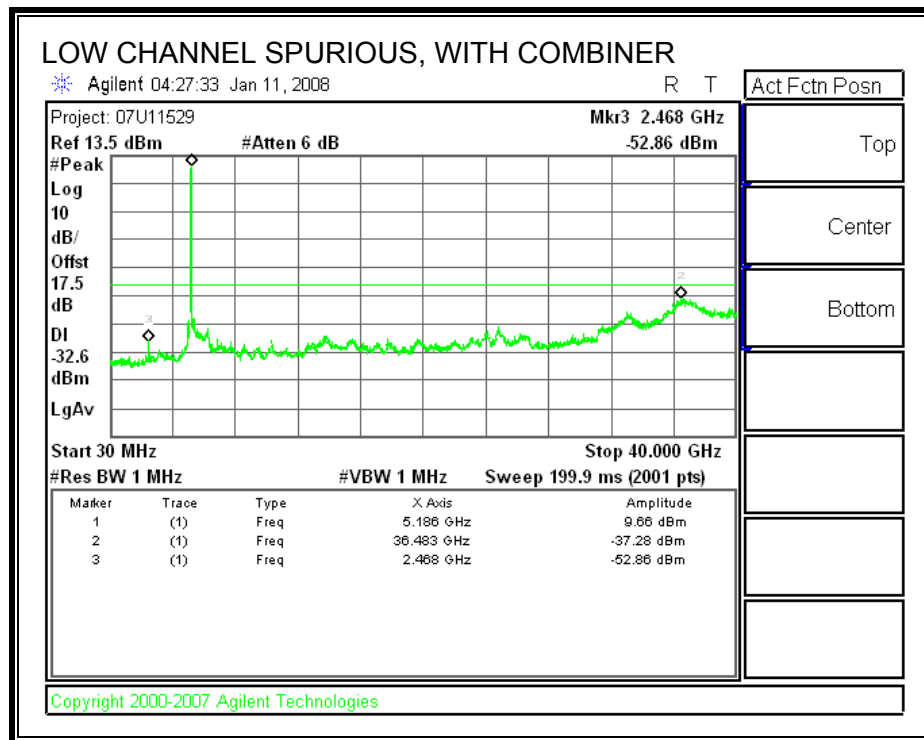

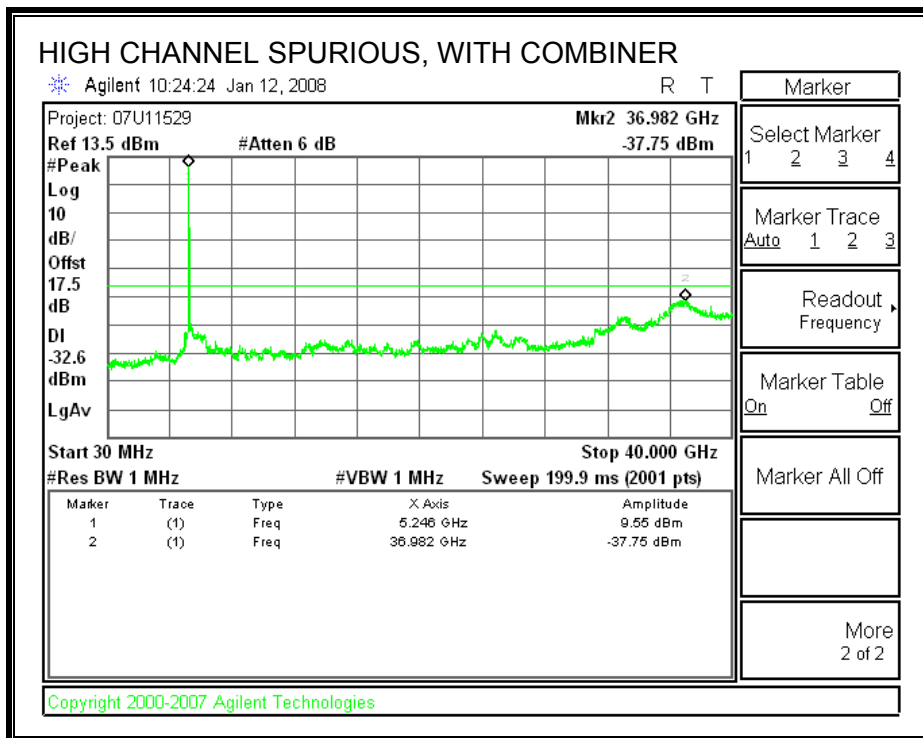
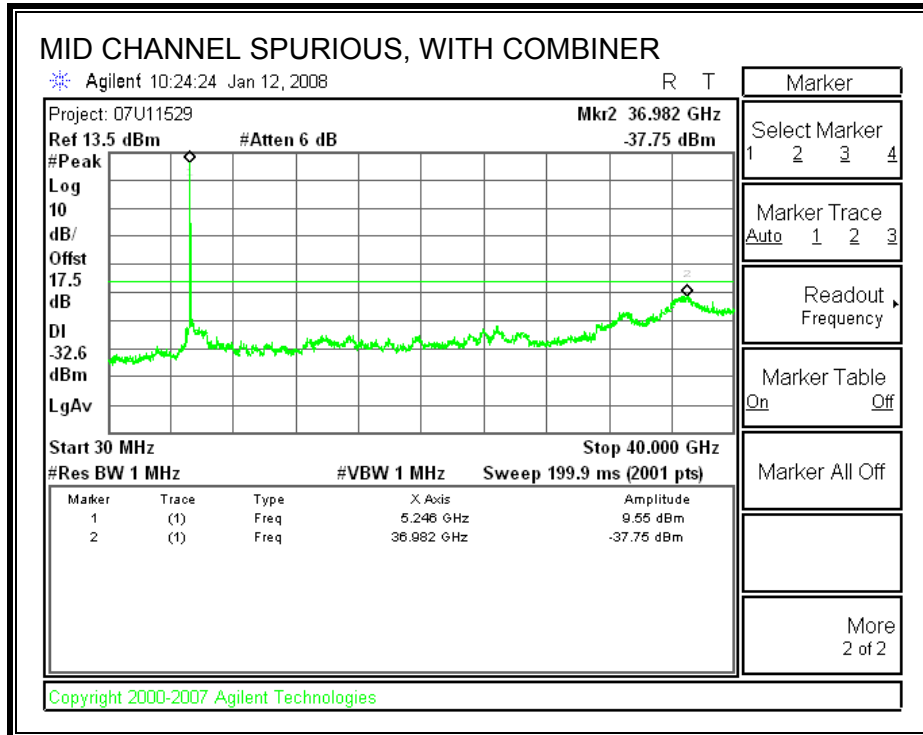

7.3. 802.11n HT40 MODE

7.3.1. 26 dB and 99% BANDWIDTH

LIMITS

None; for reporting purposes only.

TEST PROCEDURE

The transmitter outputs are connected to the spectrum analyzer via a combiner. The RBW is set to 1% to 3% of the measured bandwidth. The VBW is set to 3 times the RBW. The sweep time is coupled. The spectrum analyzer internal bandwidth function is utilized.

RESULTS

Channel	Frequency (MHz)	26 dB Bandwidth (MHz)	99% Bandwidth (MHz)
Low	5190	38.531	36.2652
High	5230	38.322	36.1421

26 dB and 99% BANDWIDTH

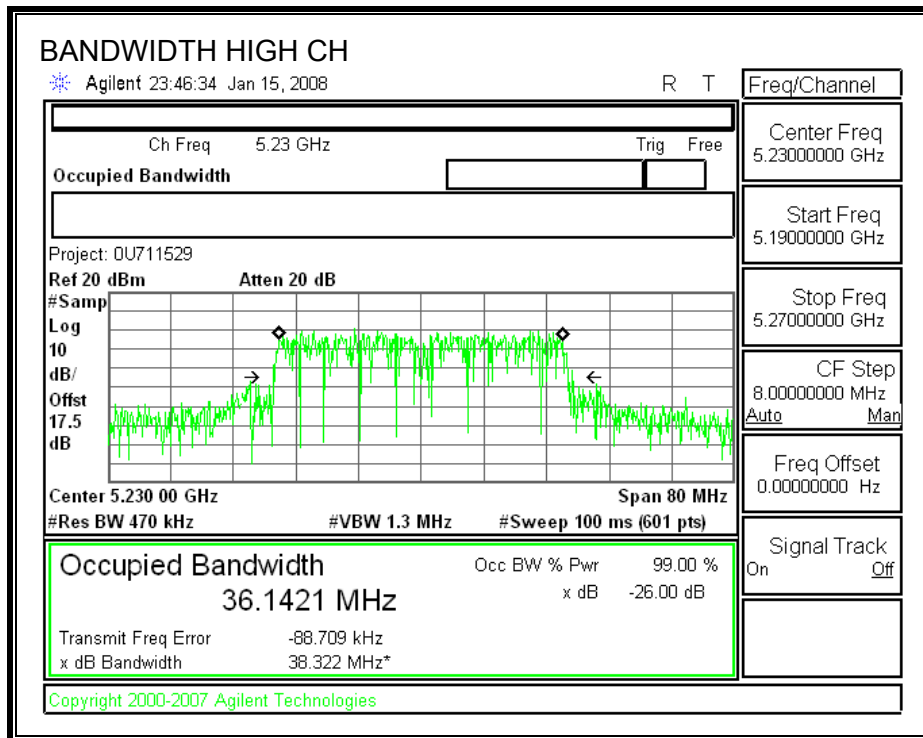
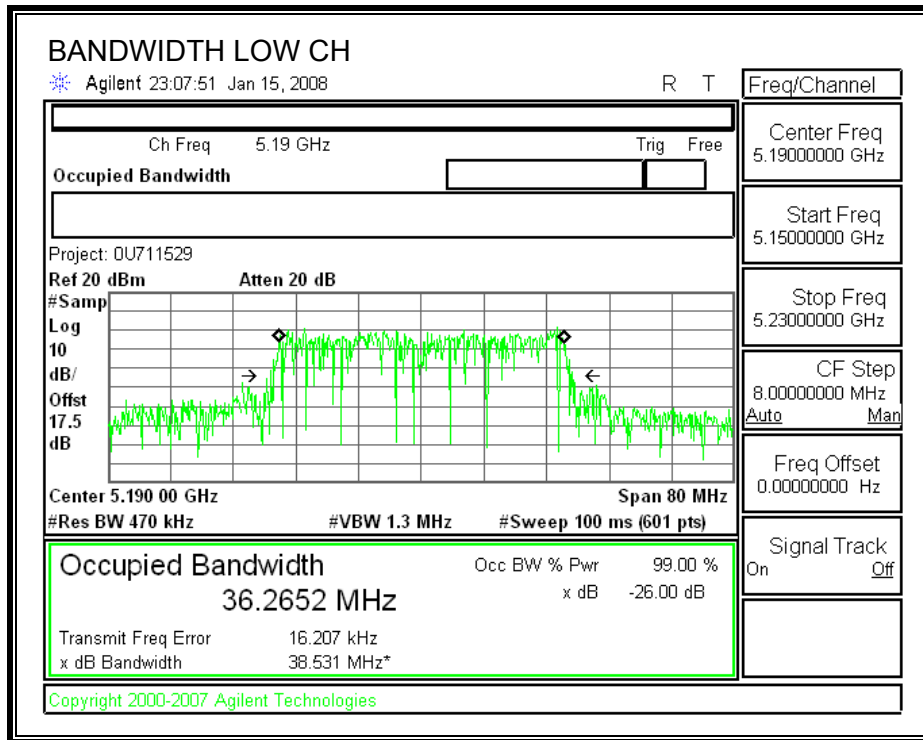

7.3.2. OUTPUT POWER

LIMITS

FCC §15.407 (a) (1)

IC RSS-210 A9.2 (1)

For the 5.15-5.25 GHz band, the maximum conducted output power over the frequency band of operation shall not exceed the lesser of 50 mW or $4 \text{ dBm} + 10 \log B$, where B is the 26-dB emission bandwidth in MHz. If transmitting antennas of directional gain greater than 6 dBi are used, both the peak transmit power and the peak power spectral density shall be reduced by the amount in dB that the directional gain of the antenna exceeds 6 dBi.

TEST PROCEDURE

The test is performed in accordance with FCC Public Notice: APPENDIX A Guidelines for Assessing Unlicensed National Information Infrastructure (U-NII) Devices – Part 15, Subpart E, August 2002.

The transmitter output operates continuously therefore Method # 1 is used.

RESULTS

6dBi Antenna Gain

Limit

Channel	Frequency (MHz)	Fixed Limit (dBm)	B (MHz)	4 + 10 Log B Limit (dBm)	Antenna Gain (dBi)	Limit (dBm)
Low	5190	17	38.531	19.86	6.00	17.00
High	5230	17	38.322	19.83	6.00	17.00

Individual Chain Results

Channel	Frequency (MHz)	Chain 0 Power (dBm)	Chain 1 Power (dBm)	Total Power (dBm)	Limit (dBm)	Margin (dB)
Low	5190	12.07	12.31	15.20	17.00	-1.80
High	5230	12.12	12.26	15.20	17.00	-1.80

8.61dBi Antenna Gain

Limit

Channel	Frequency (MHz)	Fixed Limit (dBm)	B (MHz)	4 + 10 Log B Limit (dBm)	Antenna Gain (dBi)	Limit (dBm)
Low	5190	17	38.531	19.86	8.61	14.39
High	5230	17	38.322	19.83	8.61	14.39

Individual Chain Results

Channel	Frequency (MHz)	Chain 0 Power (dBm)	Chain 1 Power (dBm)	Total Power (dBm)	Limit (dBm)	Margin (dB)
Low	5190	11.03	11.27	14.16	14.39	-0.23
High	5230	11.19	11.33	14.27	14.39	-0.12

CHAIN 0 OUTPUT POWER (With 6 dBi Antenna Gain)

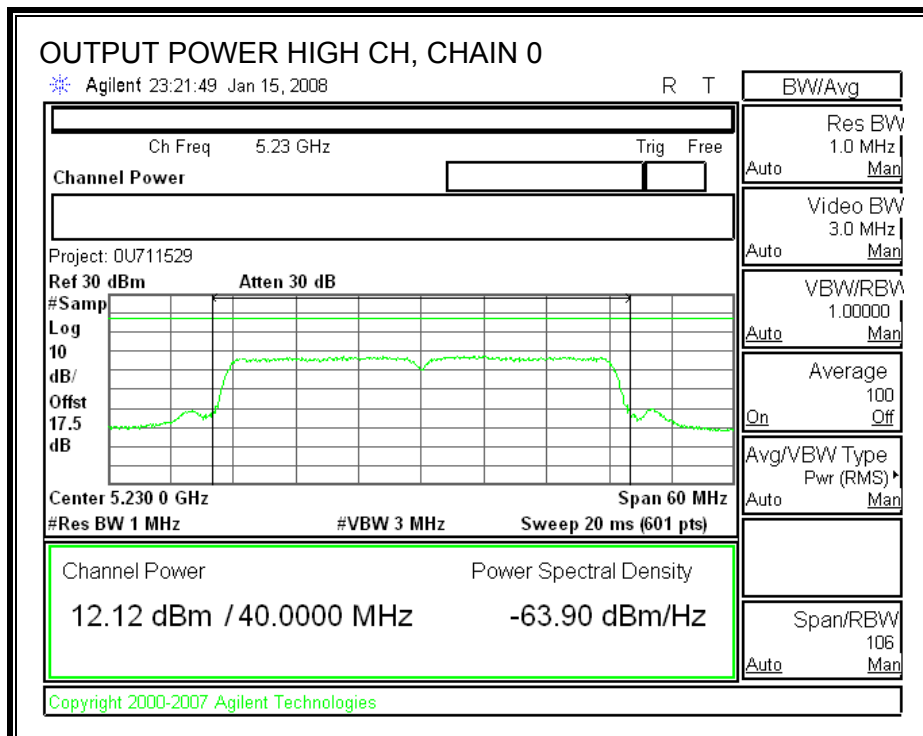
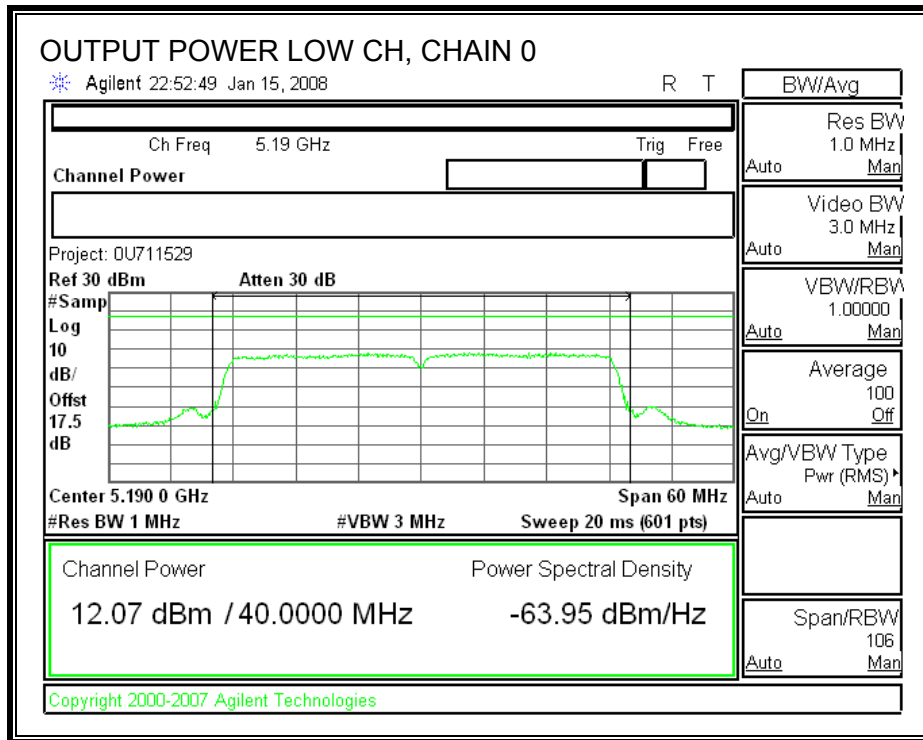

CHAIN 1 OUTPUT POWER (With 6 dBi Antenna Gain)

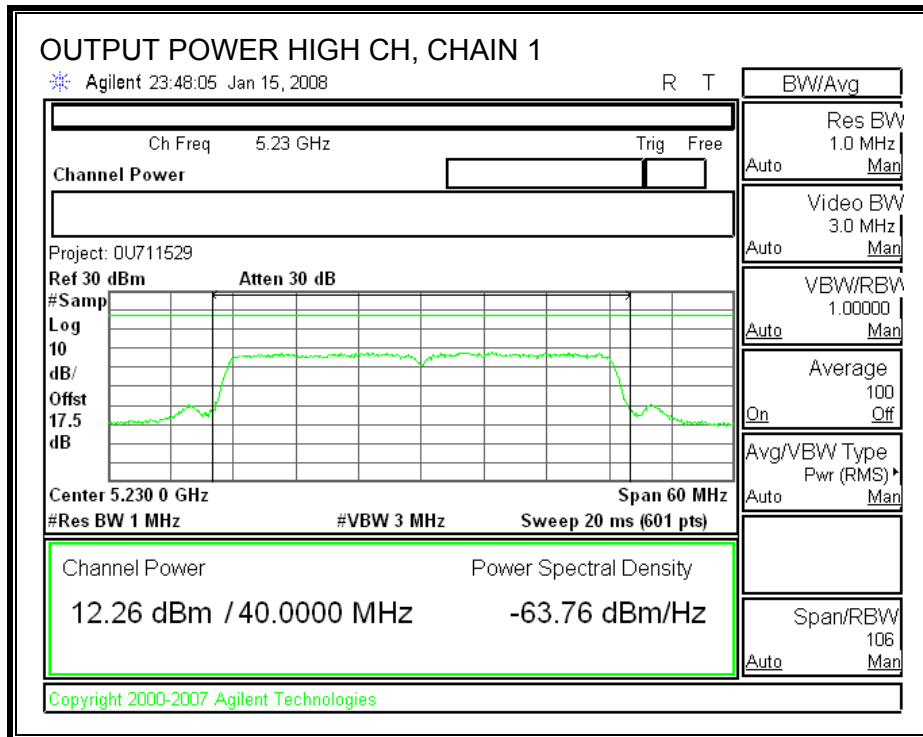
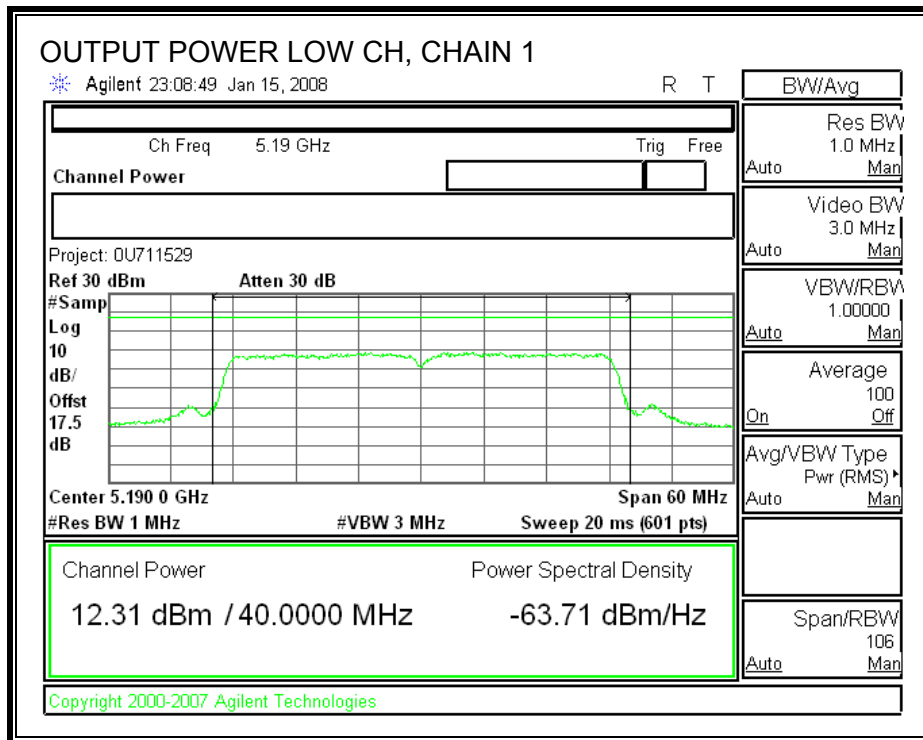

CHAIN 0 OUTPUT POWER (With 8.61 dBi Antenna Gain)

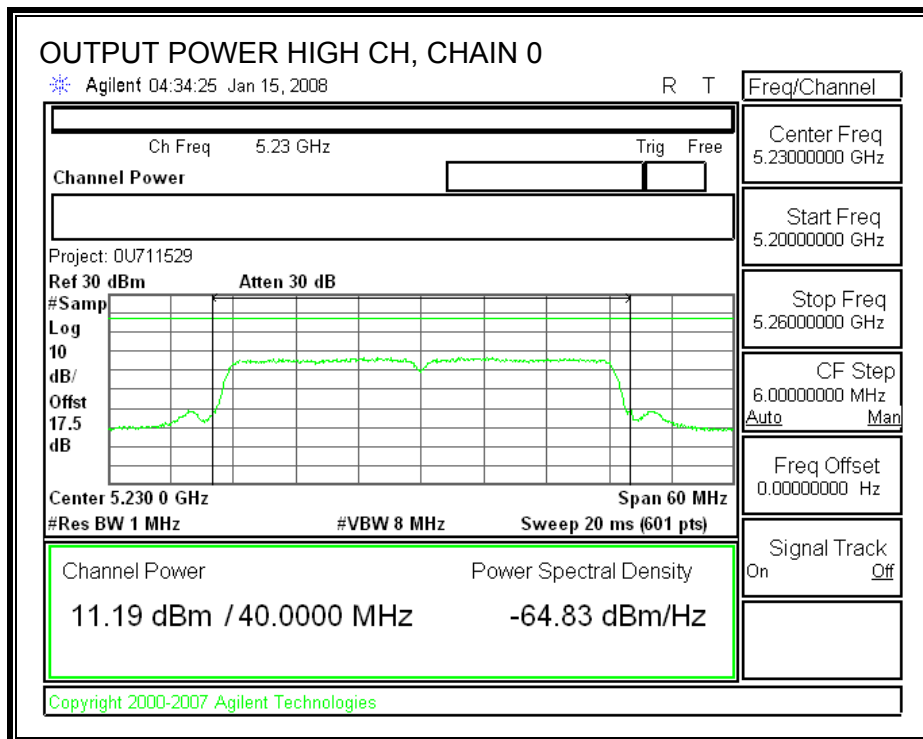
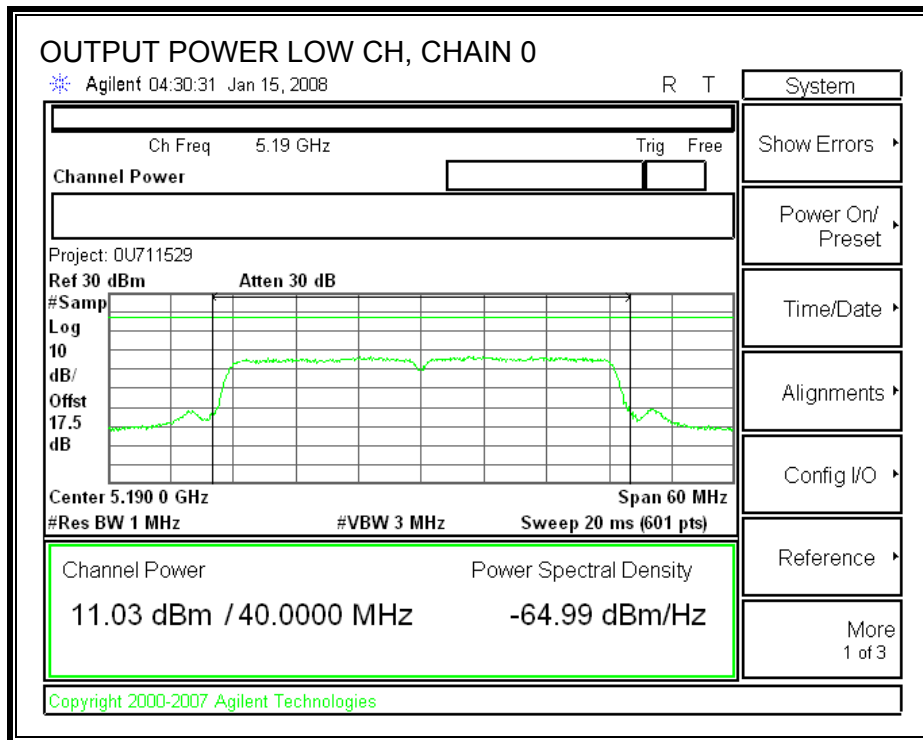

CHAIN 1 OUTPUT POWER (With 8.61 dBi Antenna Gain)

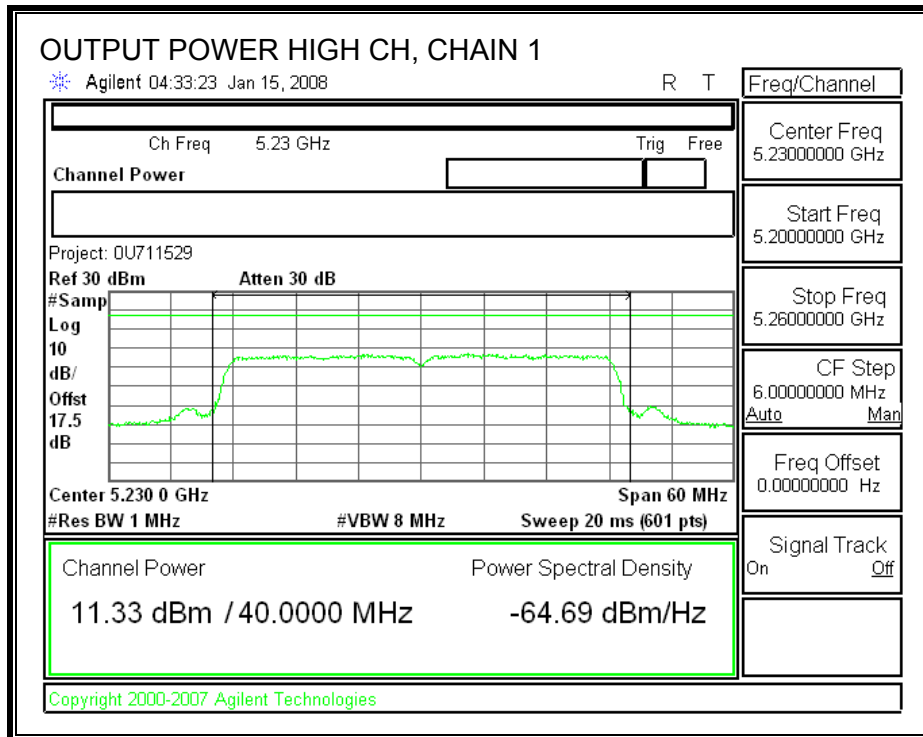
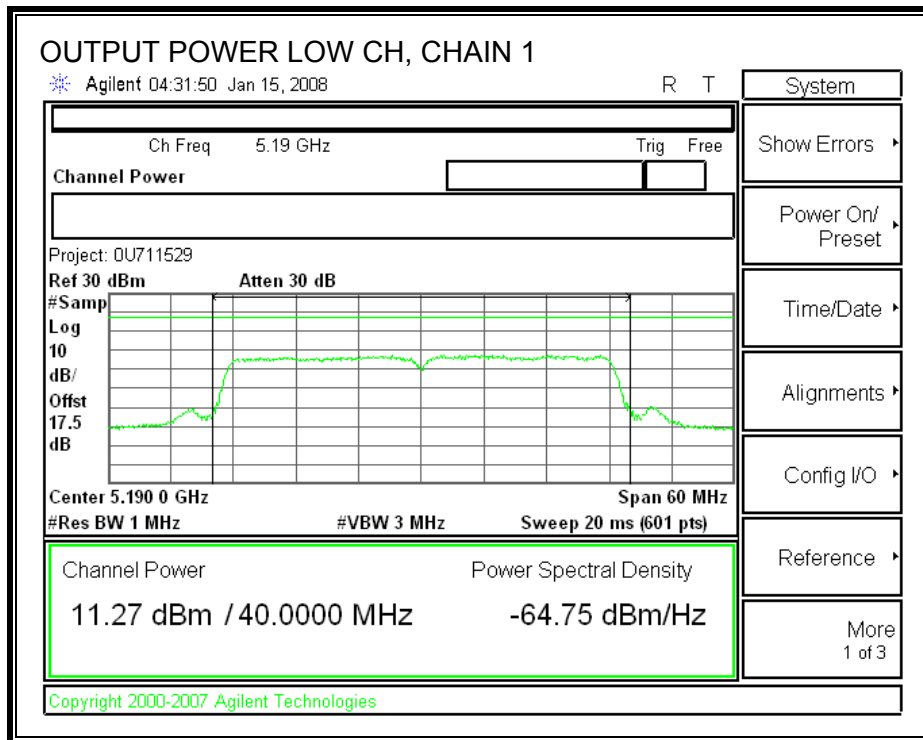

7.3.3. PEAK POWER SPECTRAL DENSITY

LIMITS

FCC §15.407 (a) (1)

IC RSS-210 A9.2 (1)

For the 5.15-5.25 GHz band, the peak power spectral density shall not exceed 4 dBm in any 1 MHz band. If transmitting antennas of directional gain greater than 6 dBi are used, both the peak transmit power and the peak power spectral density shall be reduced by the amount in dB that the directional gain of the antenna exceeds 6 dBi.

The maximum antenna gain is less than or equal to 6 dBi, therefore the limit is 4 dBm.

The maximum antenna gain is 8.61 dBi, therefore the limit is 1.39 dBm.

TEST PROCEDURE

The test is performed in accordance with FCC Public Notice: APPENDIX A Guidelines for Assessing Unlicensed National Information Infrastructure (U-NII) Devices – Part 15, Subpart E, August 2002. PPSD method #2 was used.

RESULTS

6dBi Antenna Gain

Channel	Frequency (MHz)	PPSD With Combiner (dBm)	Limit (dBm)	Margin (dB)
Low	5190	2.221	4	-1.78
High	5230	2.204	4	-1.80

8.61dBi Antenna Gain

Channel	Frequency (MHz)	PPSD With Combiner (dBm)	Limit (dBm)	Margin (dB)
Low	5190	1.113	1.39	-0.28
High	5230	1.005	1.39	-0.39

POWER SPECTRAL DENSITY WITH COMBINER (6 dBi Antenna Gain)

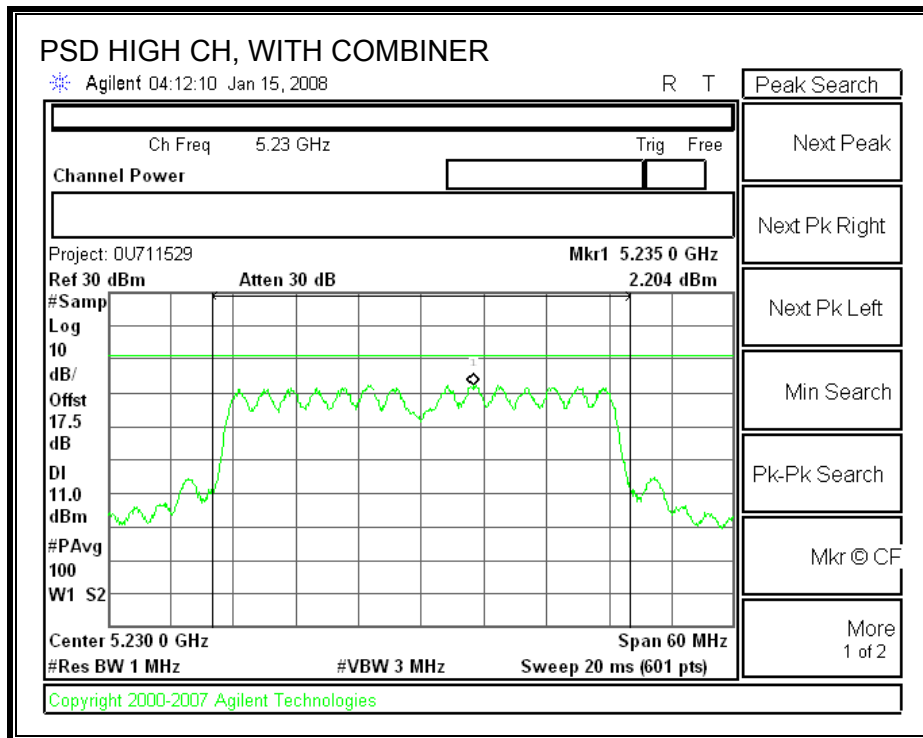
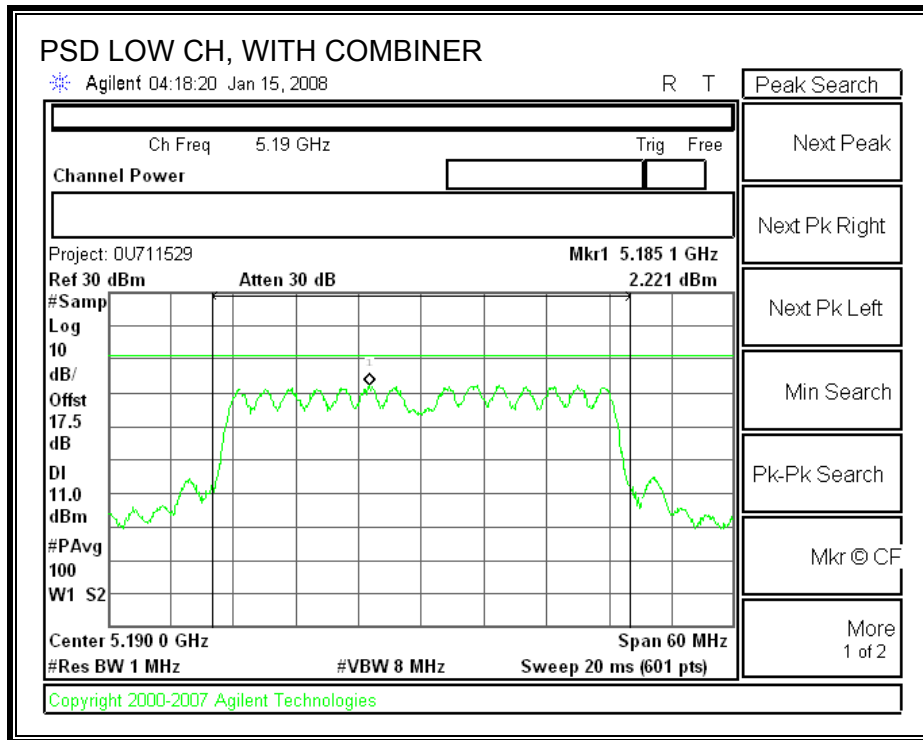

POWER SPECTRAL DENSITY WITH COMBINER (8.61 dBi Antenna Gain)

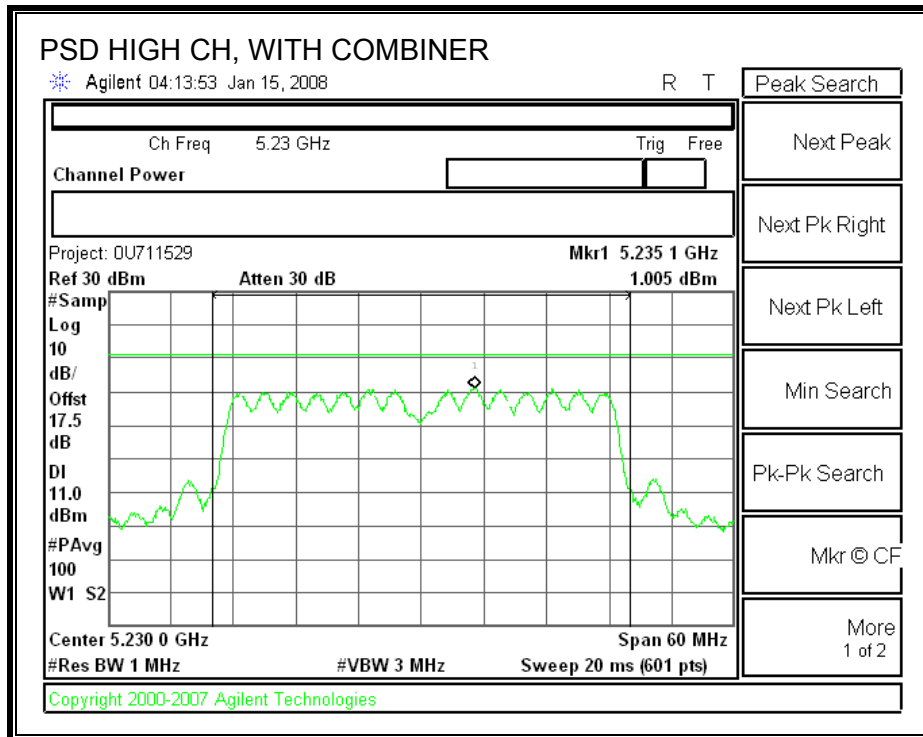
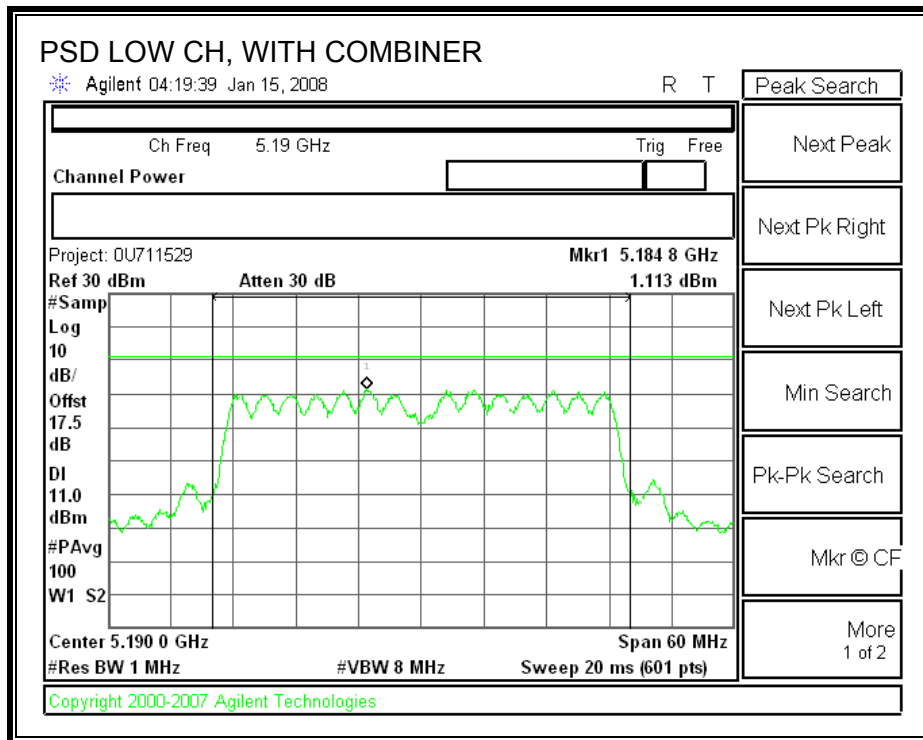

7.3.4. PEAK EXCURSION

LIMITS

FCC §15.407 (a) (6)

The ratio of the peak excursion of the modulation envelope (measured using a peak hold function) to the peak transmit power (measured as specified above) shall not exceed 13 dB across any 1 MHz bandwidth or the emission bandwidth whichever is less.

TEST PROCEDURE

The transmitter outputs are connected to the spectrum analyzer via a combiner.

The test is performed in accordance with FCC Public Notice: APPENDIX A Guidelines for Assessing Unlicensed National Information Infrastructure (U-NII) Devices – Part 15, Subpart E, August 2002.

Since Method # 1 was used for peak power measurements, Method # 1 settings are used for the second PPSD trace.

RESULTS

CHAIN 0

Channel	Frequency (MHz)	Peak Excursion (dB)	Limit (dB)	Margin (dB)
Low	5190	11.90	13	-1.10
High	5230	10.30	13	-2.70

CHAIN 1

Channel	Frequency (MHz)	Peak Excursion (dB)	Limit (dB)	Margin (dB)
Low	5190	10.79	13	-2.21
High	5230	10.25	13	-2.75

PEAK EXCURSION (CHAIN 0)

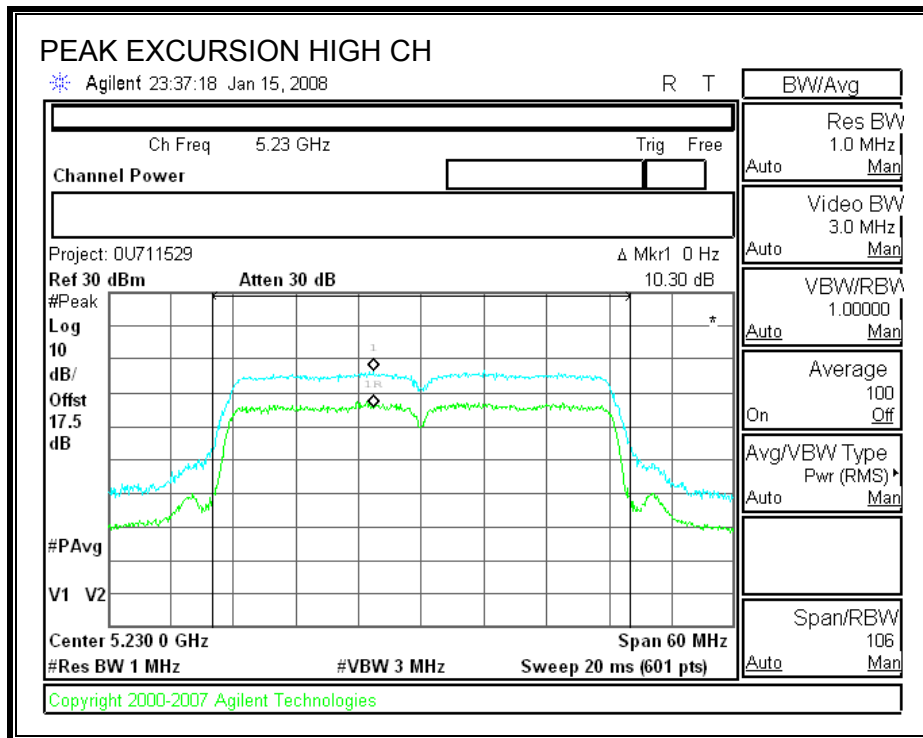
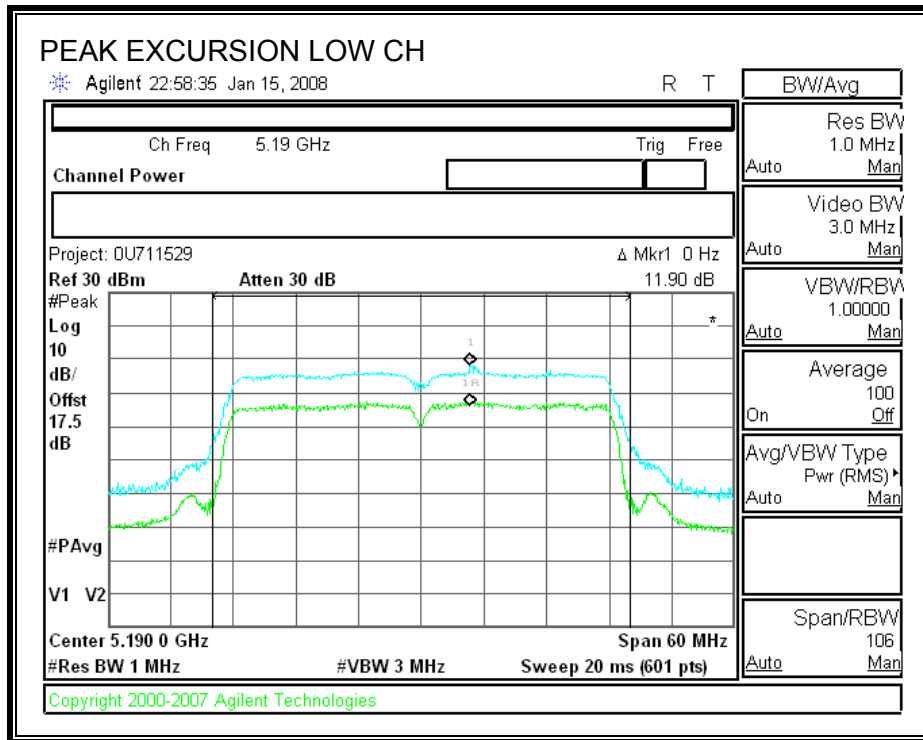

PEAK EXCURSION (CHAIN 1)

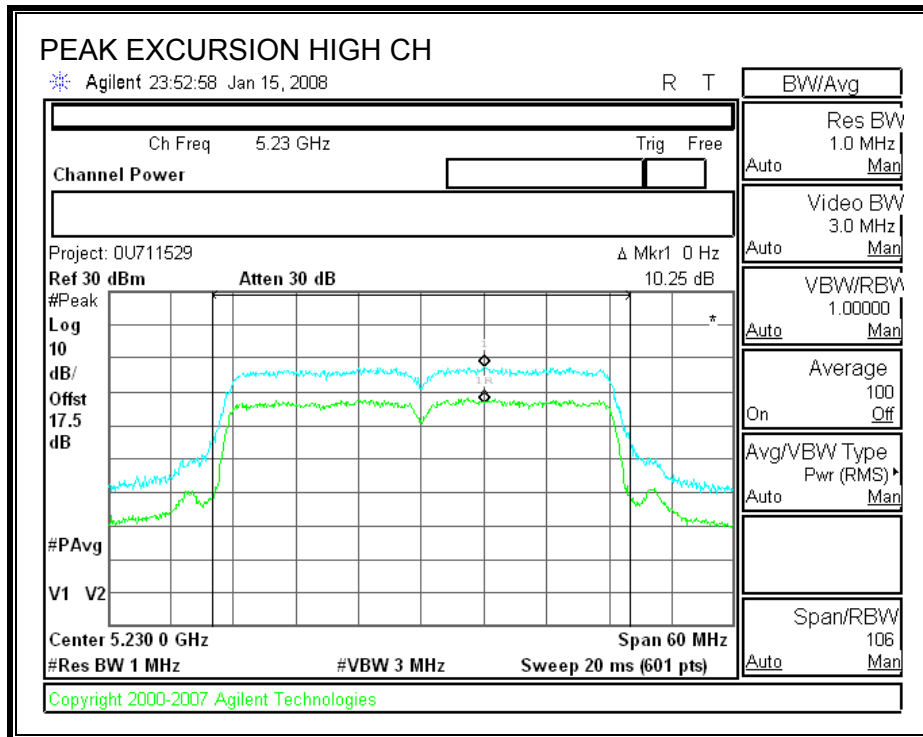
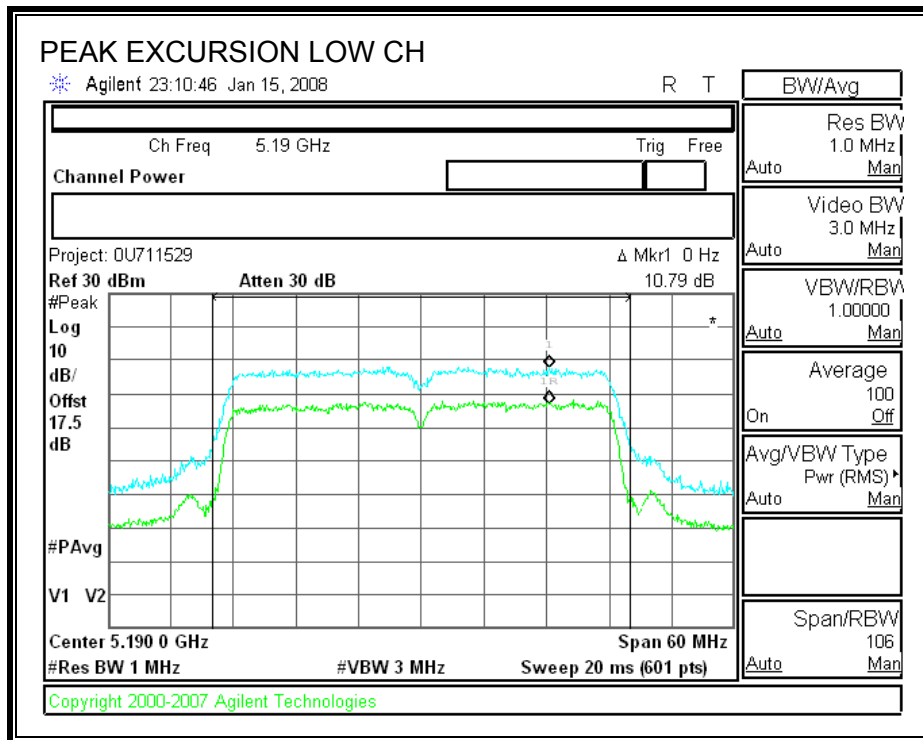

7.3.5. CONDUCTED SPURIOUS EMISSIONS

LIMITS

FCC §15.407 (b) (1)

IC RSS-210 A9.3 (1)

For transmitters operating in the 5.15-5.25 GHz band: all emissions outside of the 5.15-5.35 GHz band shall not exceed an EIRP of -27 dBm / MHz.

Limit line = -27 - EUT Antenna Gain

TEST PROCEDURE

Conducted RF measurements of the transmitter output are made to confirm that the EUT antenna port conducted emissions meet the specified limit and to identify any spurious signals that require further investigation or measurements on the radiated emissions site.

The transmitter output is connected to the spectrum analyzer. The resolution bandwidth is set to 1 MHz. The video bandwidth is set to 1 MHz. Peak detection measurements are compared to the average EIRP limit, adjusted for the maximum antenna gain. If necessary, additional average detection measurements are made.

Measurements are made over the 30 MHz to 40 GHz range with the transmitter set to the lowest, middle, and highest channels.

RESULTS

SPURIOUS EMISSIONS WITH COMBINER

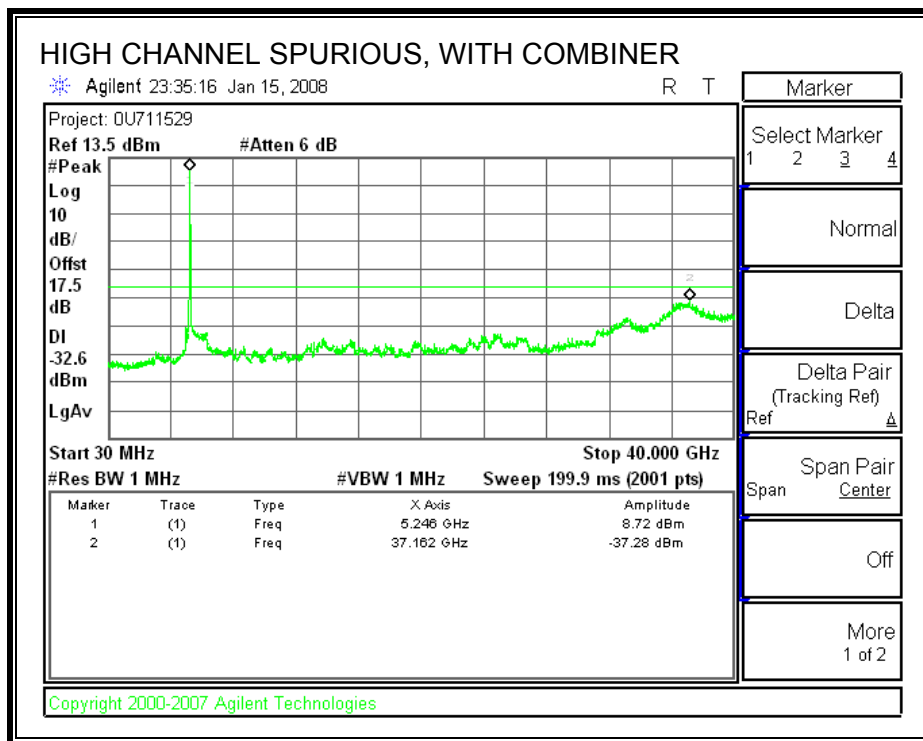
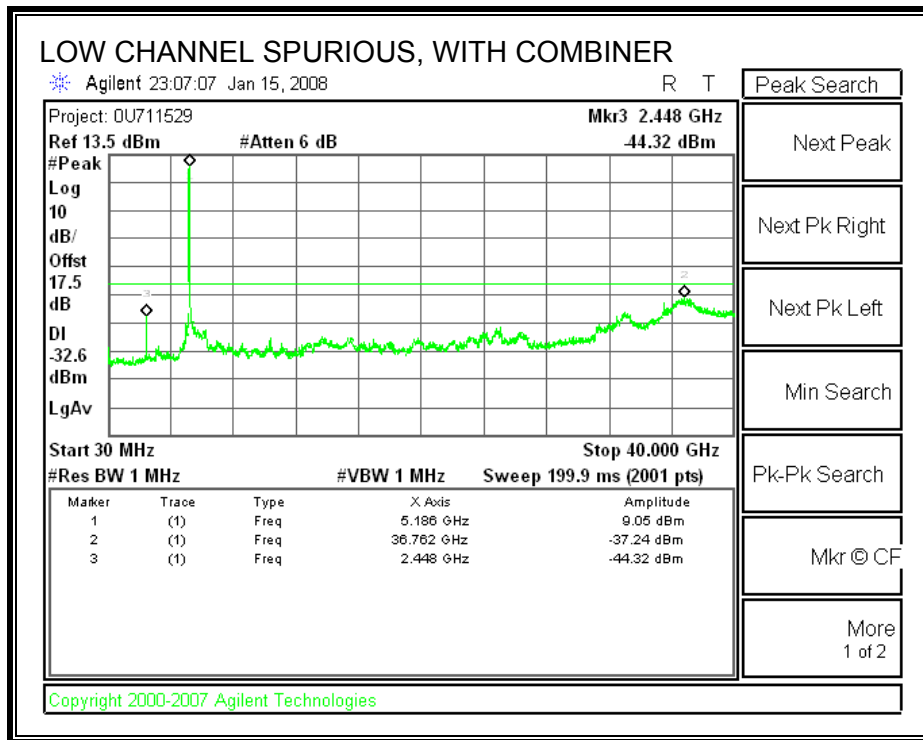

8. ANTENNA PORT TEST RESULTS FOR THE 5.25–5.35 GHZ

8.1. 802.11a MODE

8.1.1. 26 dB and 99% BANDWIDTH

LIMITS

None; for reporting purposes only.

TEST PROCEDURE

The transmitter output is connected to the spectrum analyzer. The RBW is set to 1% to 3% of the measured bandwidth. The VBW is set to 3 times the RBW. The sweep time is coupled. The spectrum analyzer internal bandwidth function is utilized.

RESULTS

Channel	Frequency (MHz)	26 dB Bandwidth (MHz)	99% Bandwidth (MHz)
Low	5260	23.422	16.4938
Middle	5300	22.991	16.5078
High	5320	22.527	16.4531

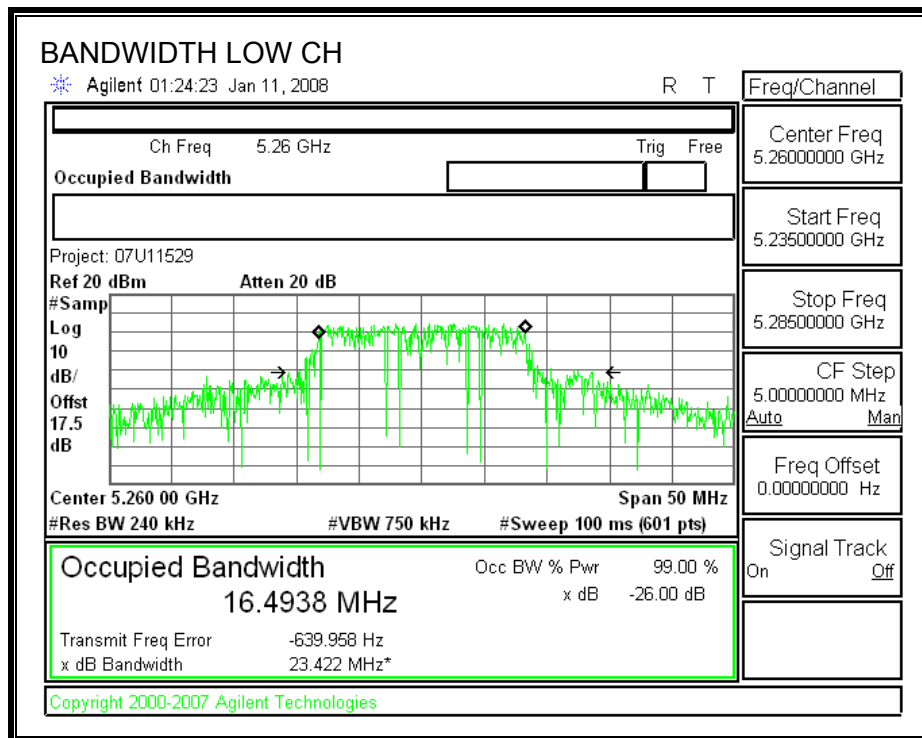

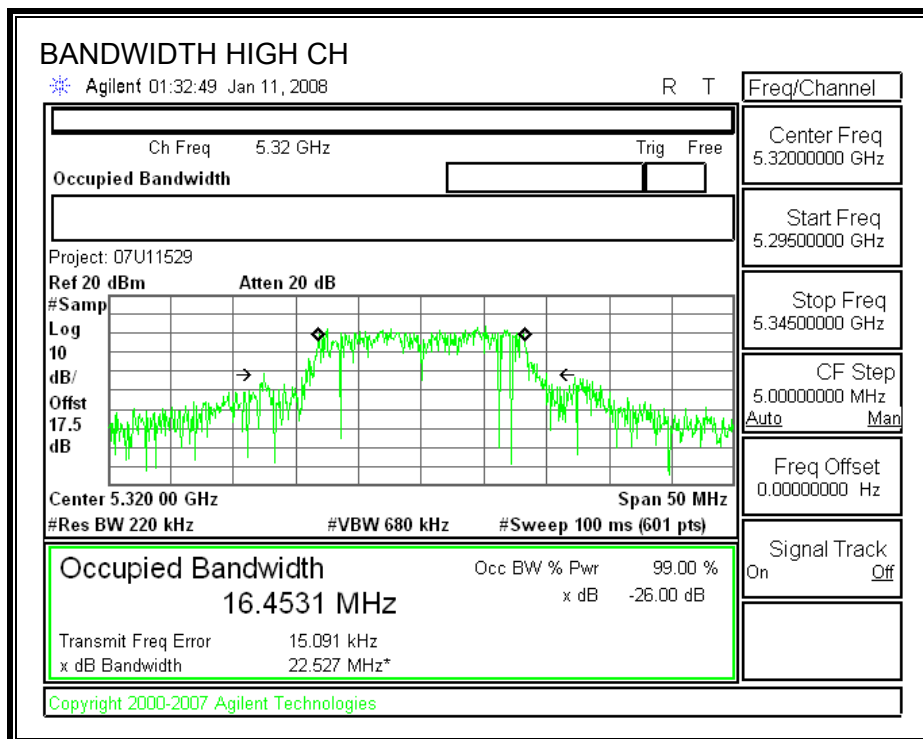
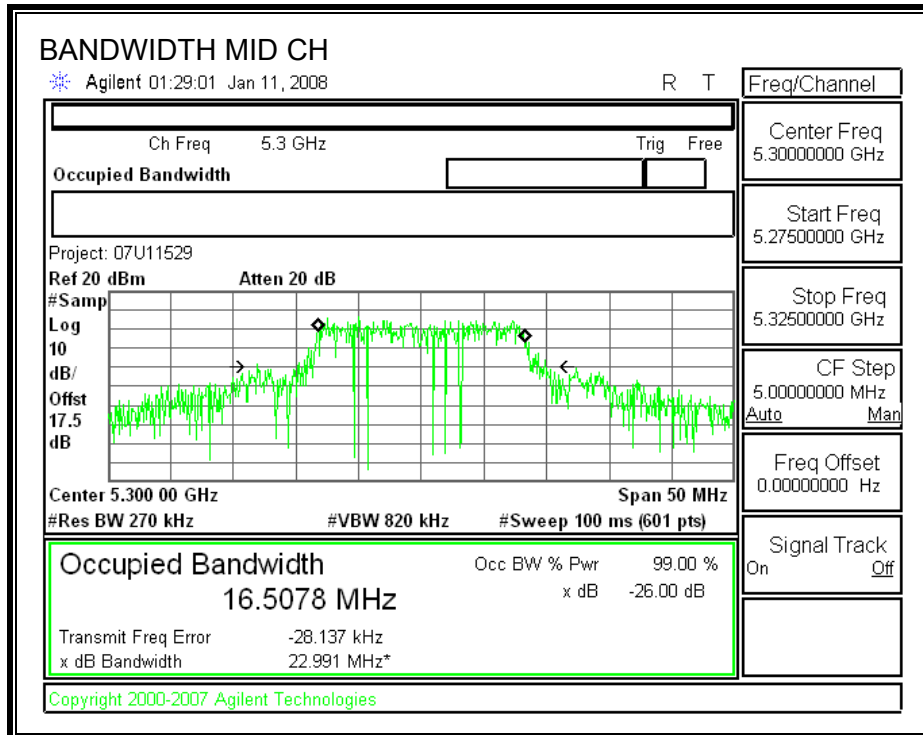

8.1.2. OUTPUT POWER

LIMITS

FCC §15.407 (a) (2)

IC RSS-210 A9.2 (2)

For the 5.25-5.35 GHz band, the maximum conducted output power over the frequency band of operation shall not exceed the lesser of 250 mW or 11 dBm + 10 log B, where B is the 26-dB emission bandwidth in MHz. If transmitting antennas of directional gain greater than 6 dBi are used, both the peak transmit power and the peak power spectral density shall be reduced by the amount in dB that the directional gain of the antenna exceeds 6 dBi.

TEST PROCEDURE

The test is performed in accordance with FCC Public Notice: APPENDIX A Guidelines for Assessing Unlicensed National Information Infrastructure (U-NII) Devices – Part 15, Subpart E, August 2002.

The transmitter output operates continuously therefore Method # 1 is used.

RESULTS

Limit

Channel	Frequency (MHz)	Fixed Limit (dBm)	B (MHz)	11 + 10 Log B Limit (dBm)	Antenna Gain (dBi)	Limit (dBm)
Low	5260	24	16.4938	23.17	5.60	23.17
Mid	5300	24	16.5078	23.18	5.60	23.18
High	5320	24	16.4531	23.16	5.60	23.16

Results

Channel	Frequency (MHz)	Power (dBm)	Limit (dBm)	Margin (dB)
Low	5260	17.63	23.17	-5.54
Mid	5300	17.80	23.18	-5.38
High	5320	15.53	23.16	-7.63

OUTPUT POWER

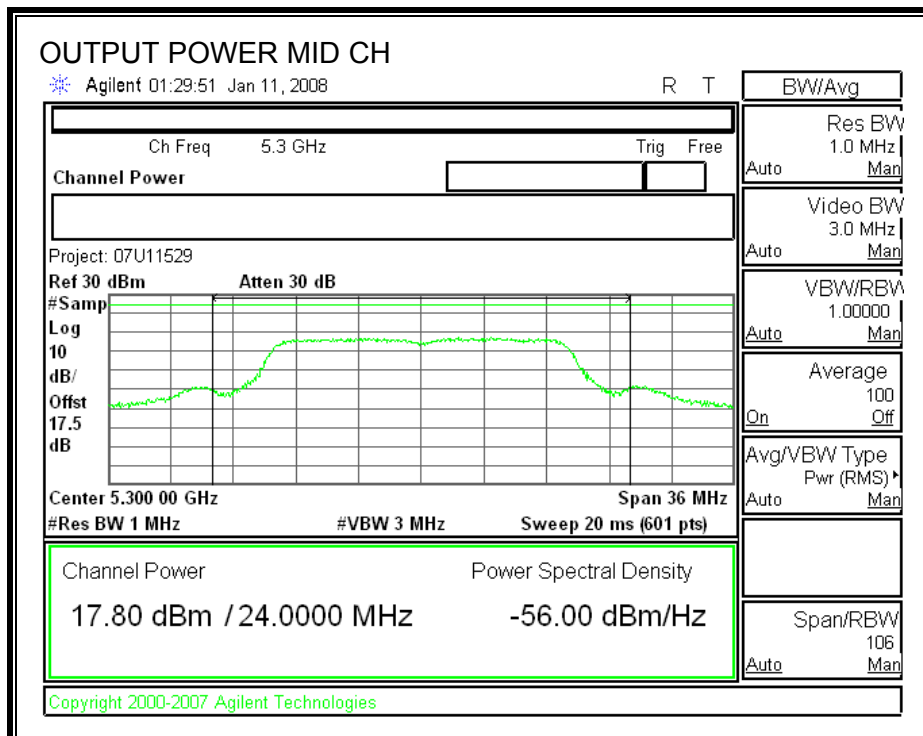
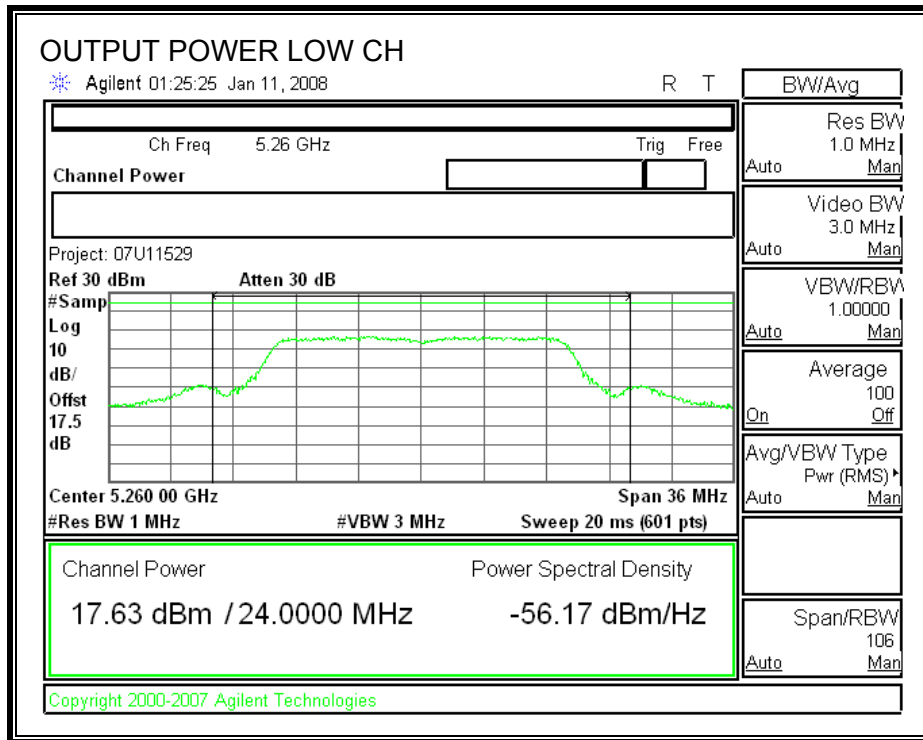

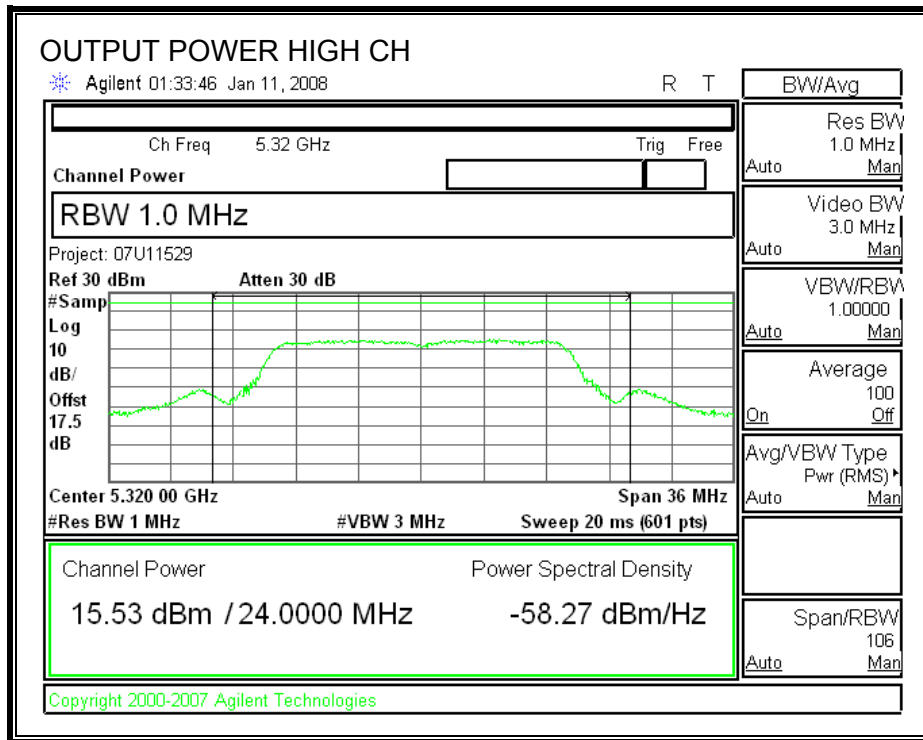

8.1.3. PEAK POWER SPECTRAL DENSITY

LIMITS

FCC §15.407 (a) (2)

IC RSS-210 A9.2 (2)

For the 5.25–5.35 GHz band, the peak power spectral density shall not exceed 11 dBm in any 1 MHz band. If transmitting antennas of directional gain greater than 6 dBi are used, both the peak transmit power and the peak power spectral density shall be reduced by the amount in dB that the directional gain of the antenna exceeds 6 dBi.

The maximum antenna gain is less than or equal to 6 dBi, therefore the limit is 11 dBm.

TEST PROCEDURE

The test is performed in accordance with FCC Public Notice: APPENDIX A Guidelines for Assessing Unlicensed National Information Infrastructure (U-NII) Devices – Part 15, Subpart E, August 2002. PPSD method #2 was used.

RESULTS

Channel	Frequency (MHz)	PPSD (dBm)	Limit (dBm)	Margin (dB)
Low	5260	6.70	11	-4.30
Middle	5300	7.18	11	-3.82
High	5320	5.08	11	-5.92

POWER SPECTRAL DENSITY

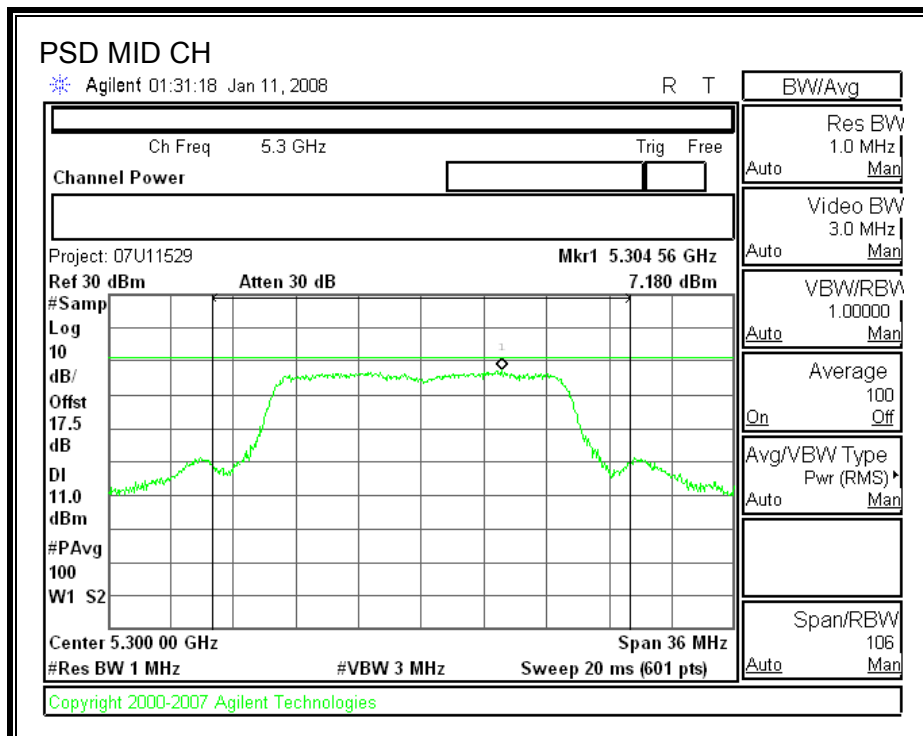
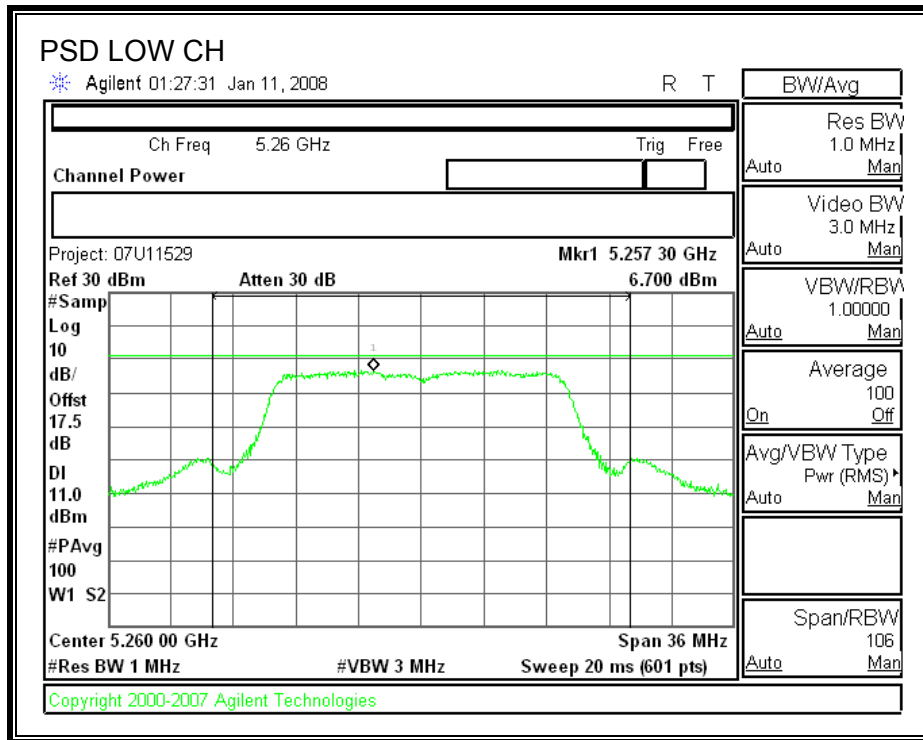

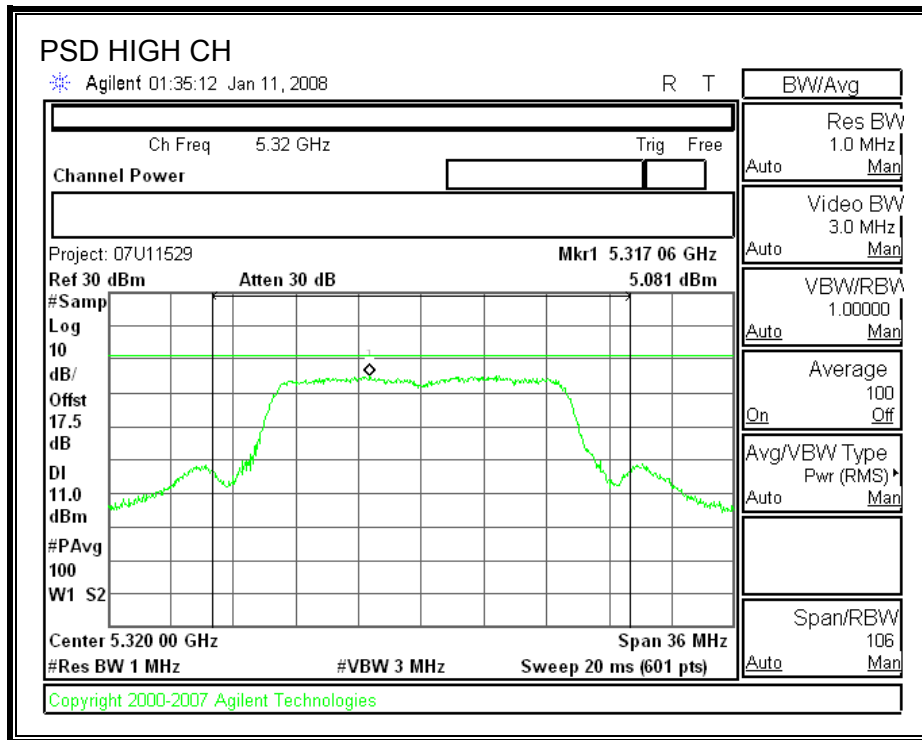

8.1.4. PEAK EXCURSION

LIMITS

FCC §15.407 (a) (6)

The ratio of the peak excursion of the modulation envelope (measured using a peak hold function) to the peak transmit power (measured as specified above) shall not exceed 13 dB across any 1 MHz bandwidth or the emission bandwidth whichever is less.

TEST PROCEDURE

The test is performed in accordance with FCC Public Notice: APPENDIX A Guidelines for Assessing Unlicensed National Information Infrastructure (U-NII) Devices – Part 15, Subpart E, August 2002.

Since Method # 1 was used for peak power measurements, Method # 1 settings are used for the second PPSD trace.

RESULTS

Channel	Frequency (MHz)	Peak Excursion (dB)	Limit (dB)	Margin (dB)
Low	5260	10.96	13	-2.04
Middle	5300	10.81	13	-2.19
High	5320	10.03	13	-2.97

PEAK EXCURSION

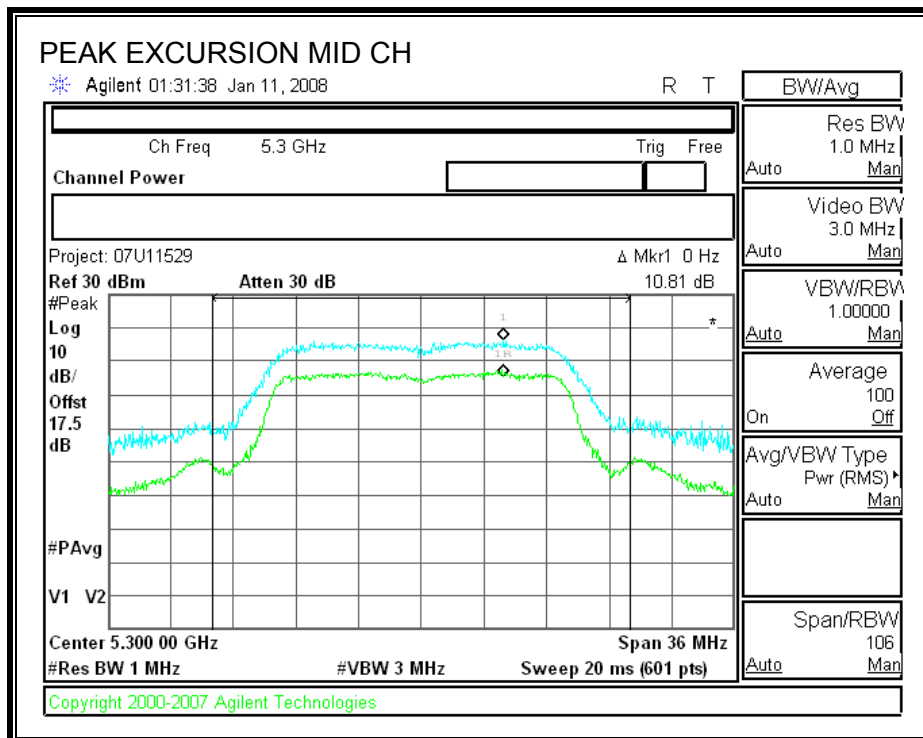
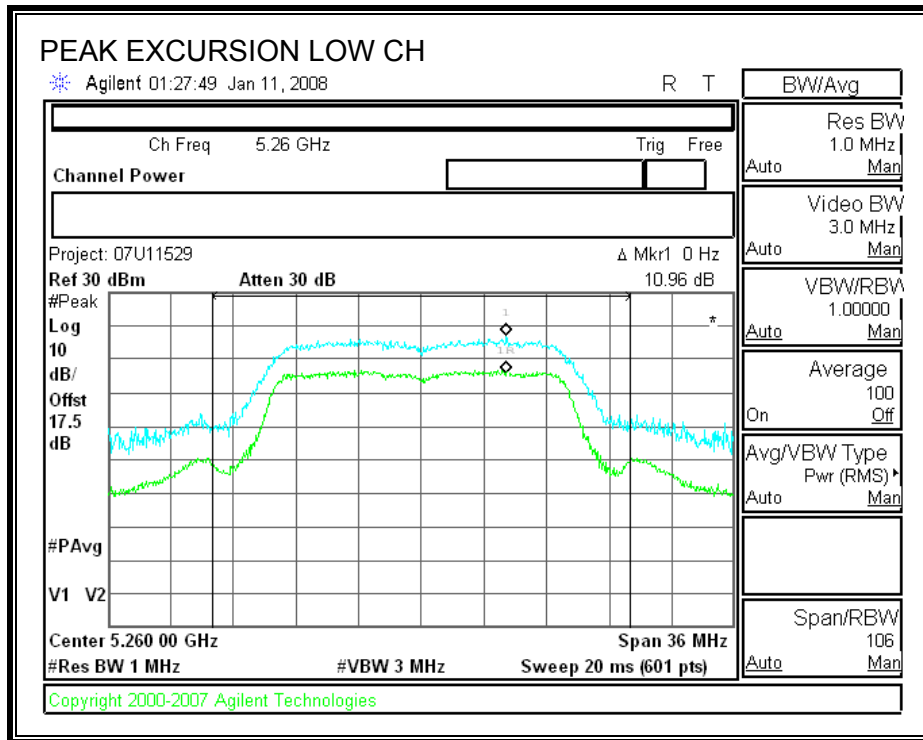

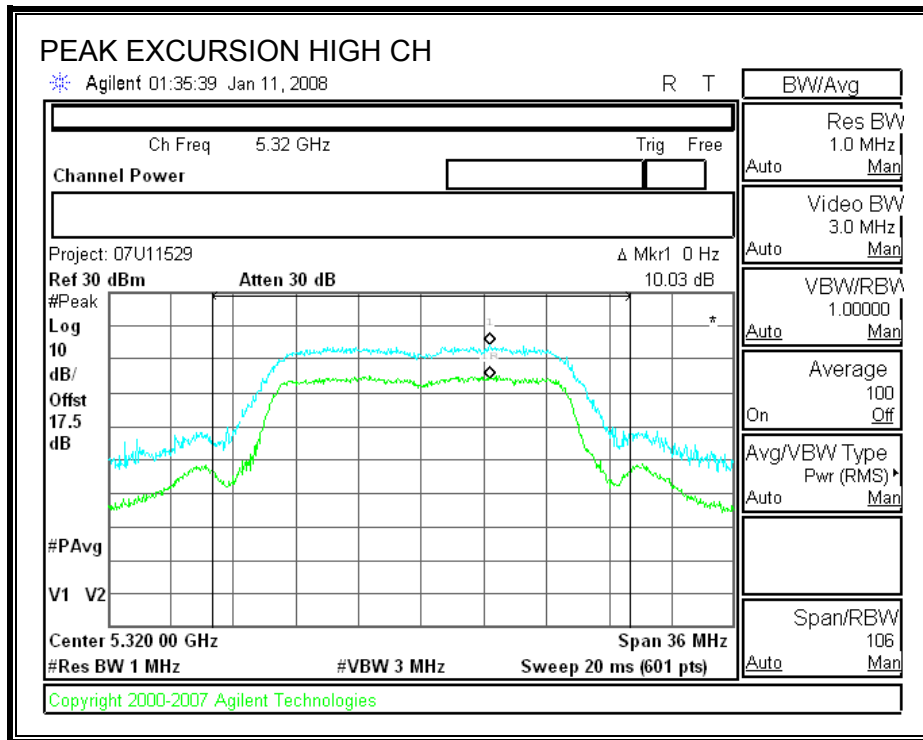

8.1.5. CONDUCTED SPURIOUS EMISSIONS

LIMITS

FCC §15.407 (b) (2)

IC RSS-210 A9.3 (2)

For transmitters operating in the 5.25-5.35 GHz band: all emissions outside of the 5.25-5.35 GHz band shall not exceed an EIRP of -27 dBm / MHz.

Devices operating in the 5.25-5.35 GHz band that generate emissions in the 5.15-5.25 GHz band must meet all applicable technical requirements for operation in the 5.15-5.25 GHz band (including indoor use) or alternatively meet an out-of-band emission EIRP limit of -27 dBm/MHz in the 5.15-5.25 GHz band.

Limit line = -27 - EUT Antenna Gain

TEST PROCEDURE

Conducted RF measurements of the transmitter output are made to confirm that the EUT antenna port conducted emissions meet the specified limit and to identify any spurious signals that require further investigation or measurements on the radiated emissions site.

The transmitter output is connected to the spectrum analyzer. The resolution bandwidth is set to 1 MHz. The video bandwidth is set to 1 MHz. Peak detection measurements are compared to the average EIRP limit, adjusted for the maximum antenna gain. If necessary, additional average detection measurements are made.

Measurements are made over the 30 MHz to 40 GHz range with the transmitter set to the lowest, middle, and highest channels.

RESULTS

SPURIOUS EMISSIONS

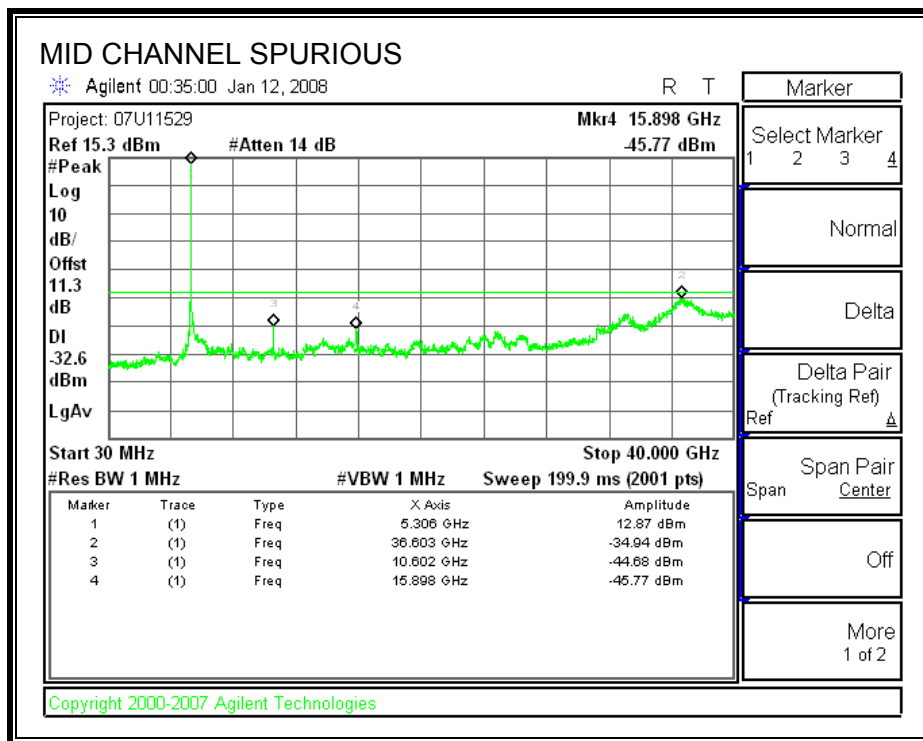
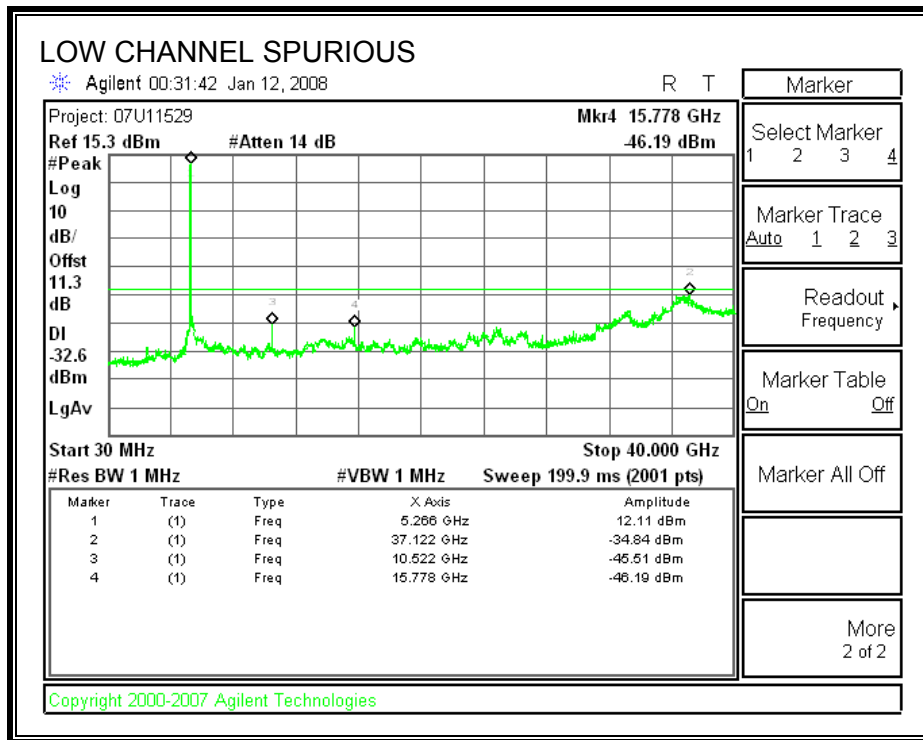

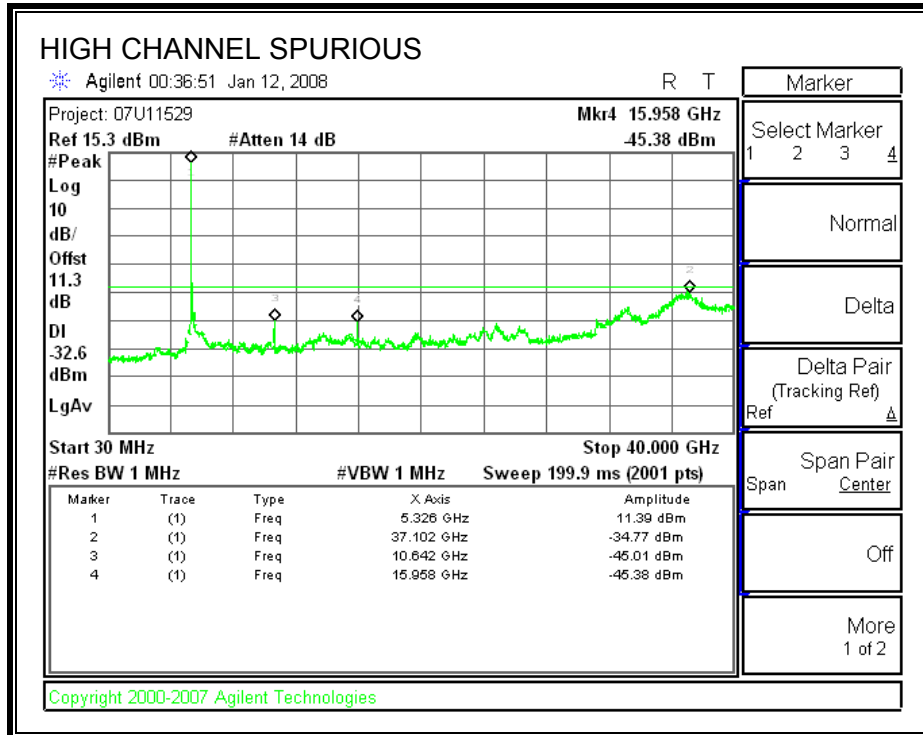

8.2. 802.11n HT20 MODE

8.2.1. 26 dB and 99% BANDWIDTH

LIMITS

None; for reporting purposes only.

TEST PROCEDURE

The transmitter outputs are connected to the spectrum analyzer. The RBW is set to 1% to 3% of the measured bandwidth. The VBW is set to 3 times the RBW. The sweep time is coupled. The spectrum analyzer internal bandwidth function is utilized.

RESULTS

Channel	Frequency (MHz)	26 dB Bandwidth (MHz)	99% Bandwidth (MHz)
Low	5260	19.655	17.6679
Middle	5300	19.251	17.7197
High	5320	20.648	17.7148

26 dB and 99% BANDWIDTH

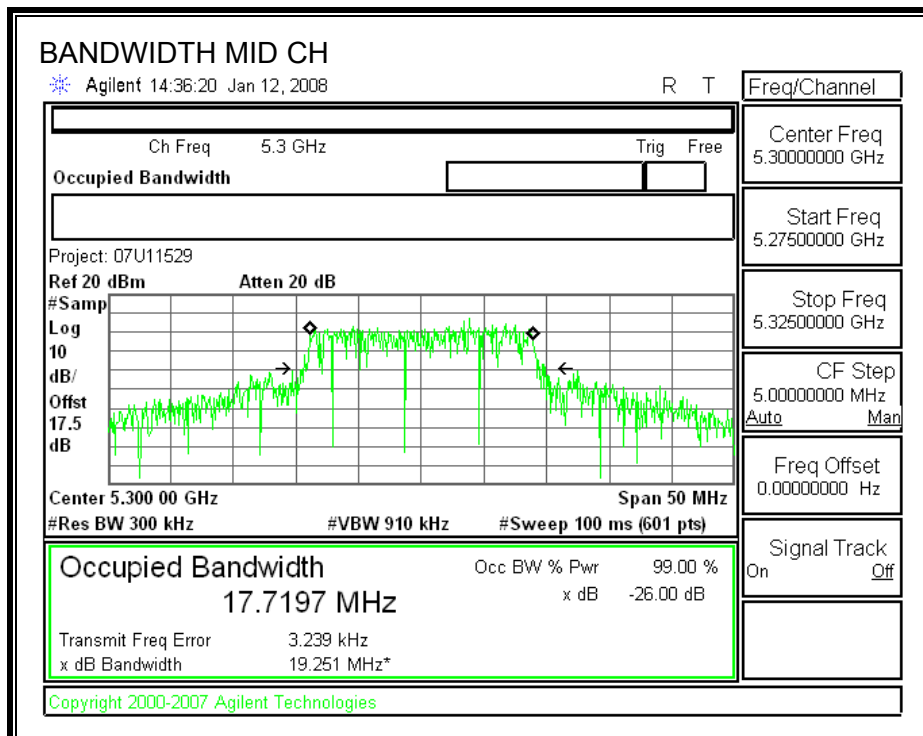
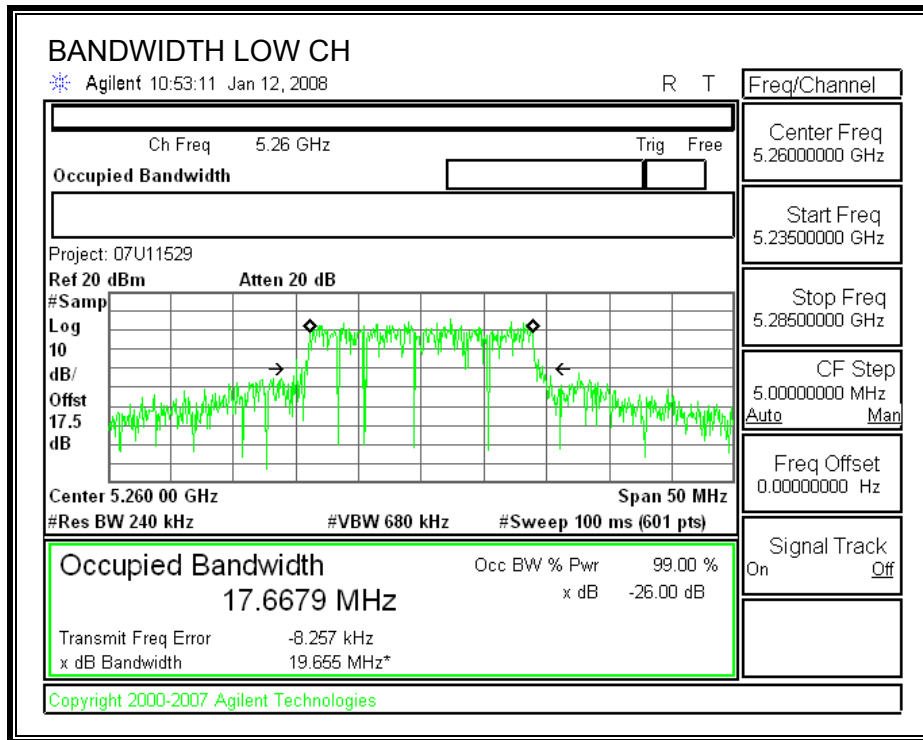

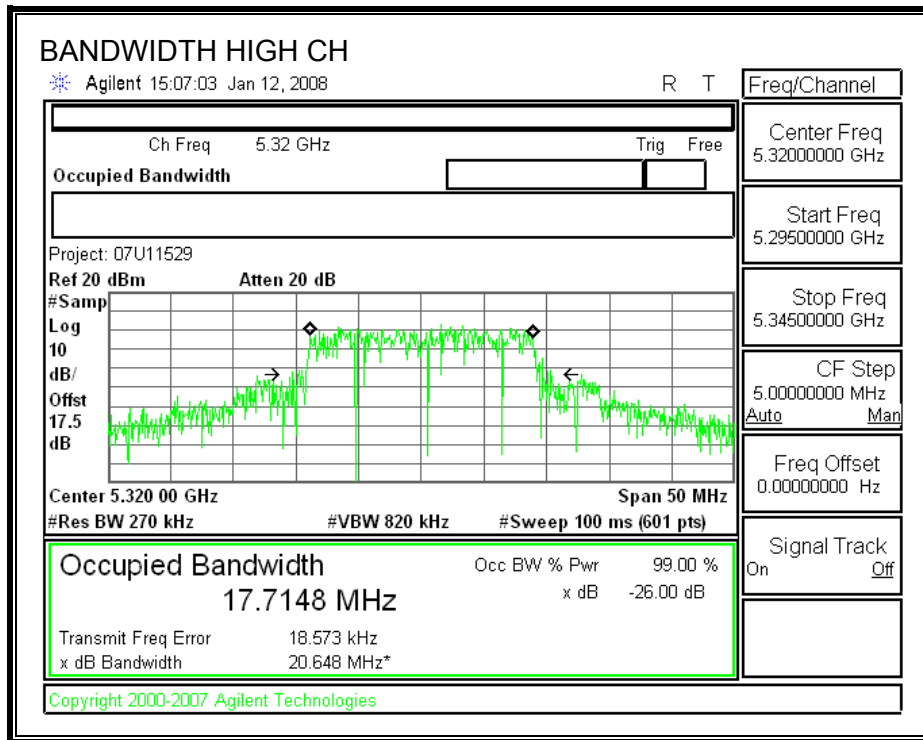

8.2.2. OUTPUT POWER

LIMITS

FCC §15.407 (a) (2)

IC RSS-210 A9.2 (2)

For the 5.25-5.35 GHz band, the maximum conducted output power over the frequency band of operation shall not exceed the lesser of 250 mW or $11 \text{ dBm} + 10 \log B$, where B is the 26-dB emission bandwidth in MHz. If transmitting antennas of directional gain greater than 6 dBi are used, both the peak transmit power and the peak power spectral density shall be reduced by the amount in dB that the directional gain of the antenna exceeds 6 dBi.

TEST PROCEDURE

The test is performed in accordance with FCC Public Notice: APPENDIX A Guidelines for Assessing Unlicensed National Information Infrastructure (U-NII) Devices – Part 15, Subpart E, August 2002.

The transmitter output operates continuously therefore Method # 1 is used.

RESULTS

6dBi antenna Gain

Limit

Channel	Frequency (MHz)	Fixed Limit (dBm)	B (MHz)	11 + 10 Log B Limit (dBm)	Antenna Gain (dBi)	Limit (dBm)
Low	5260	24	19.655	23.93	6.00	23.93
Mid	5300	24	19.251	23.84	6.00	23.84
High	5320	24	20.648	24.15	6.00	24.00

Individual Chain Results

Channel	Frequency (MHz)	Chain 0 Power (dBm)	Chain 1 Power (dBm)	Total Power (dBm)	Limit (dBm)	Margin (dB)
Low	5260	16.20	16.16	19.19	23.93	-4.74
Mid	5300	16.13	16.00	19.08	23.84	-4.77
High	5320	14.38	14.36	17.38	24.00	-6.62

8.61dBi antenna Gain

Note:

High channel still meets the Peak Power and PPSD limits of high antenna gain. It utilizes the same power level for all antennas; and the power data of high channel in table below is from 6dBi data.

Limit

Channel	Frequency (MHz)	Fixed Limit (dBm)	B (MHz)	11 + 10 Log B Limit (dBm)	Antenna Gain (dBi)	Limit (dBm)
Low	5260	24	19.655	23.93	6.00	23.93
Mid	5300	24	19.251	23.84	6.00	23.84
High	5320	24	20.648	24.15	6.00	24.00

Individual Chain Results

Channel	Frequency (MHz)	Chain 0 Power (dBm)	Chain 1 Power (dBm)	Total Power (dBm)	Limit (dBm)	Margin (dB)
Low	5260	15.29	15.17	18.24	23.93	-5.69
Mid	5300	15.24	15.25	18.26	23.84	-5.59
High	5320	14.38	14.36	17.38	24.00	-6.62

CHAIN 0 OUTPUT POWER (6 dBi Antenna Gain)

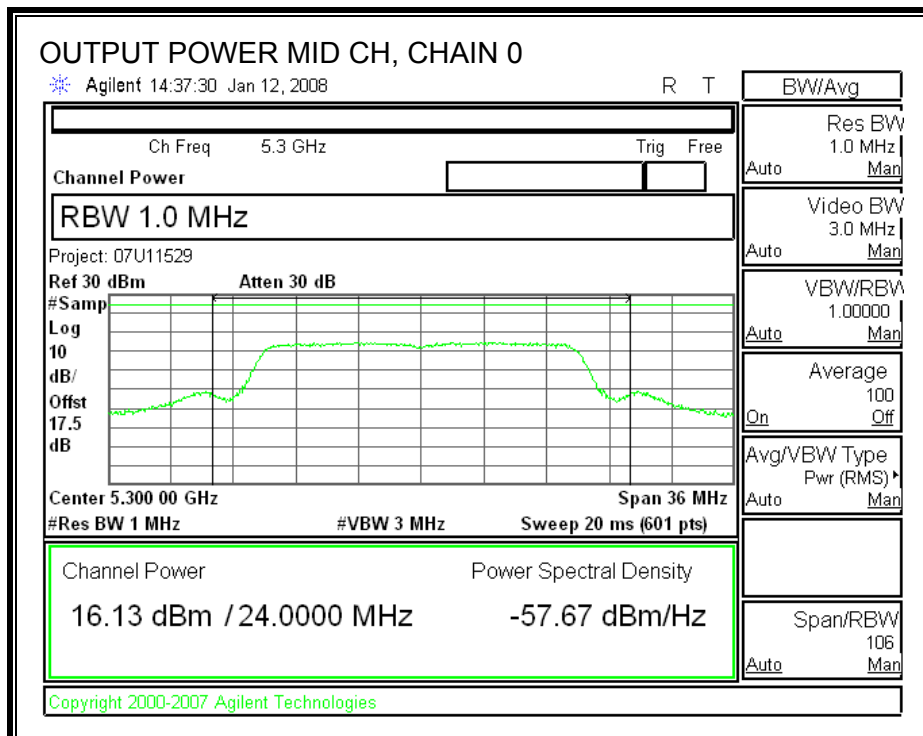
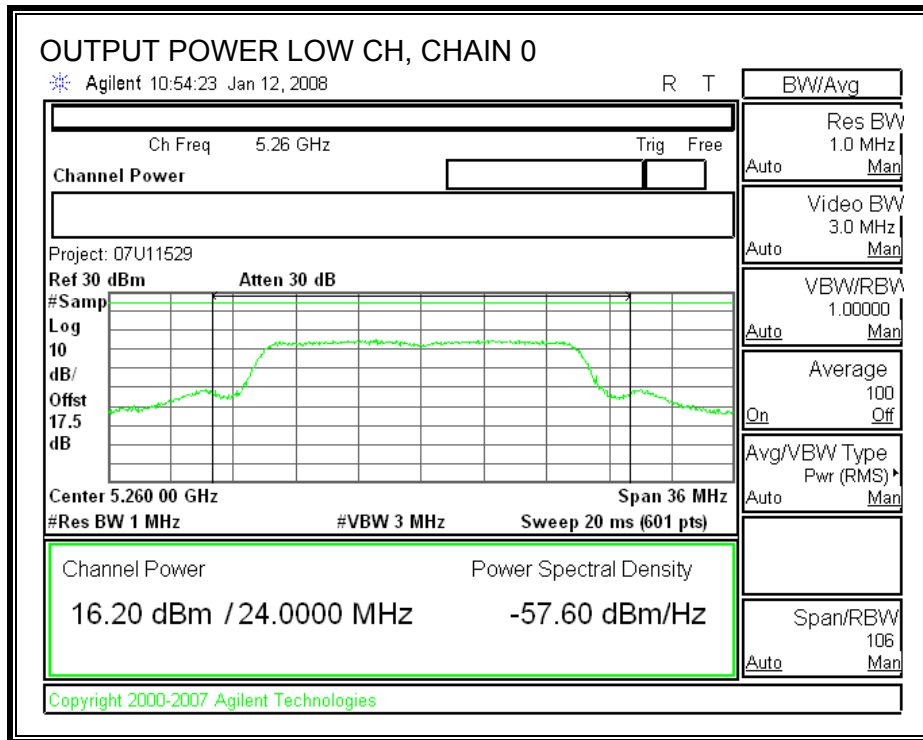

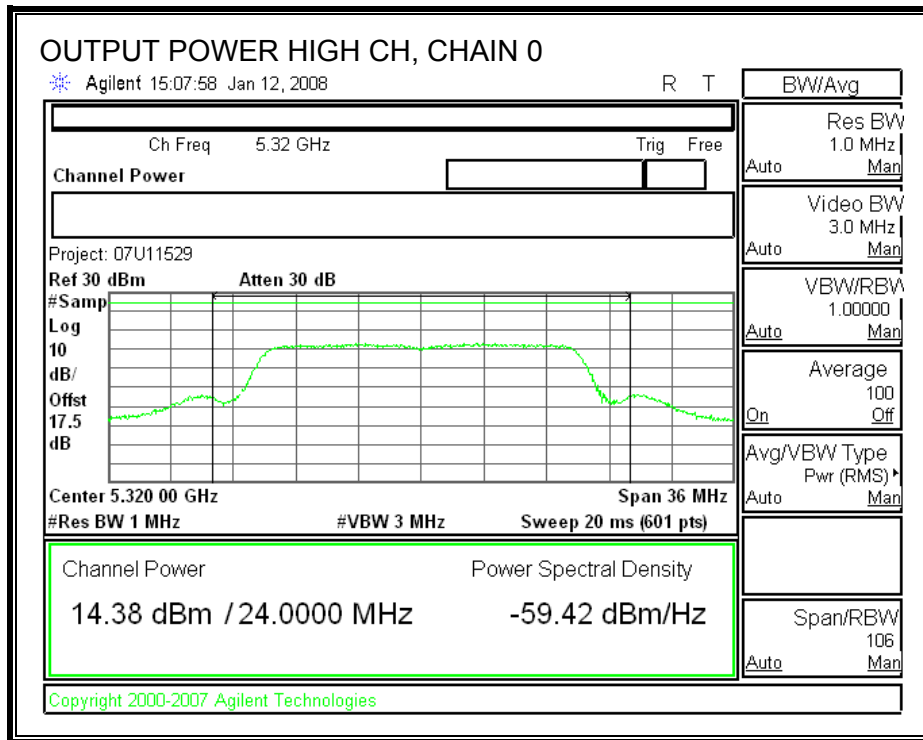

CHAIN 1 OUTPUT POWER (6 dBi Antenna Gain)

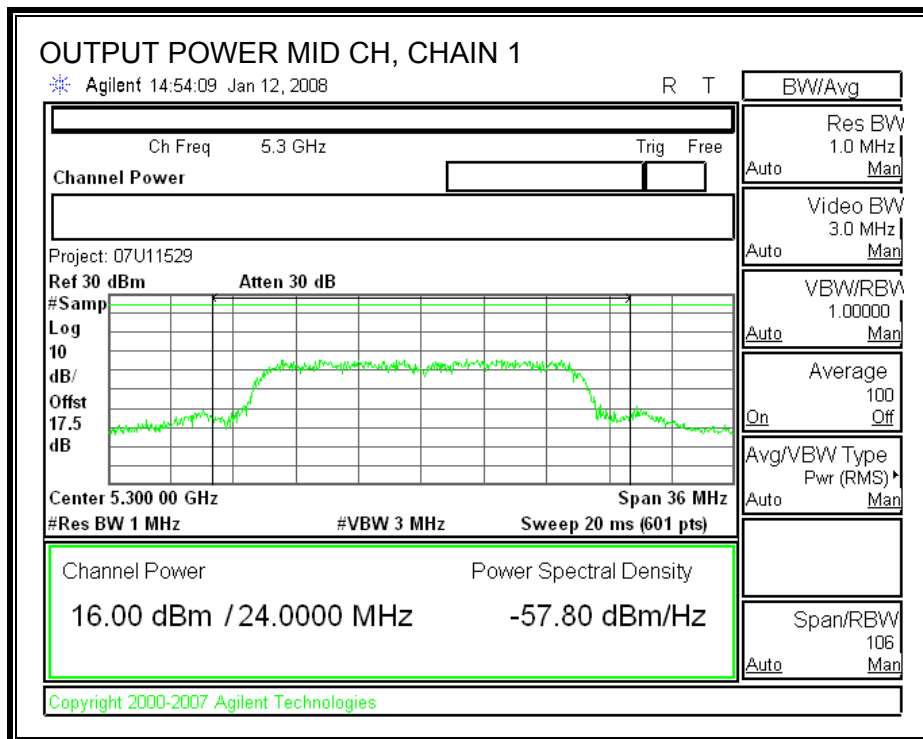
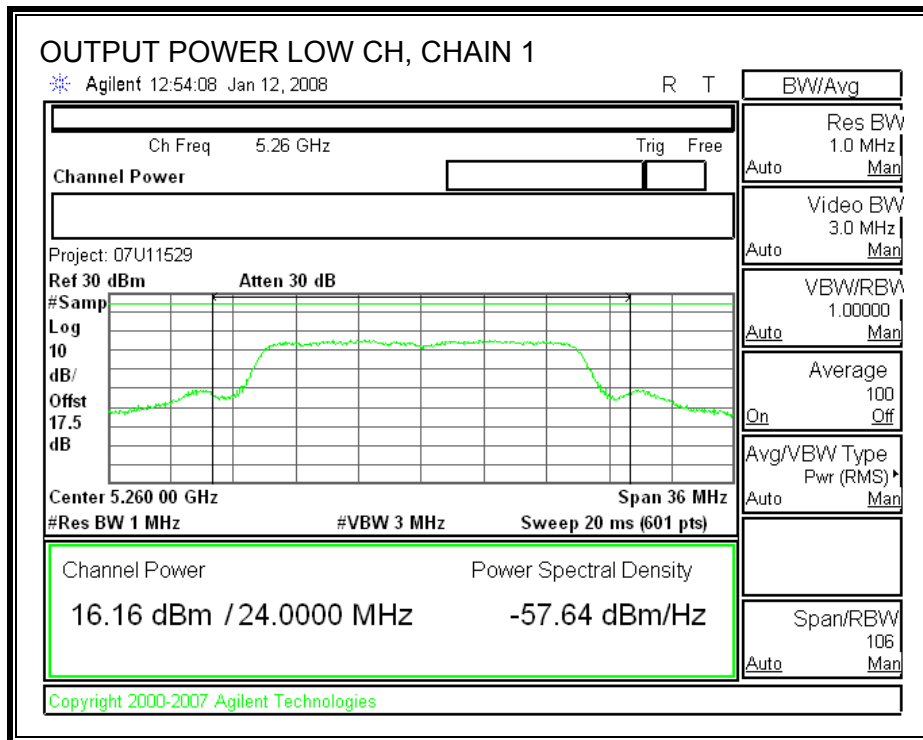

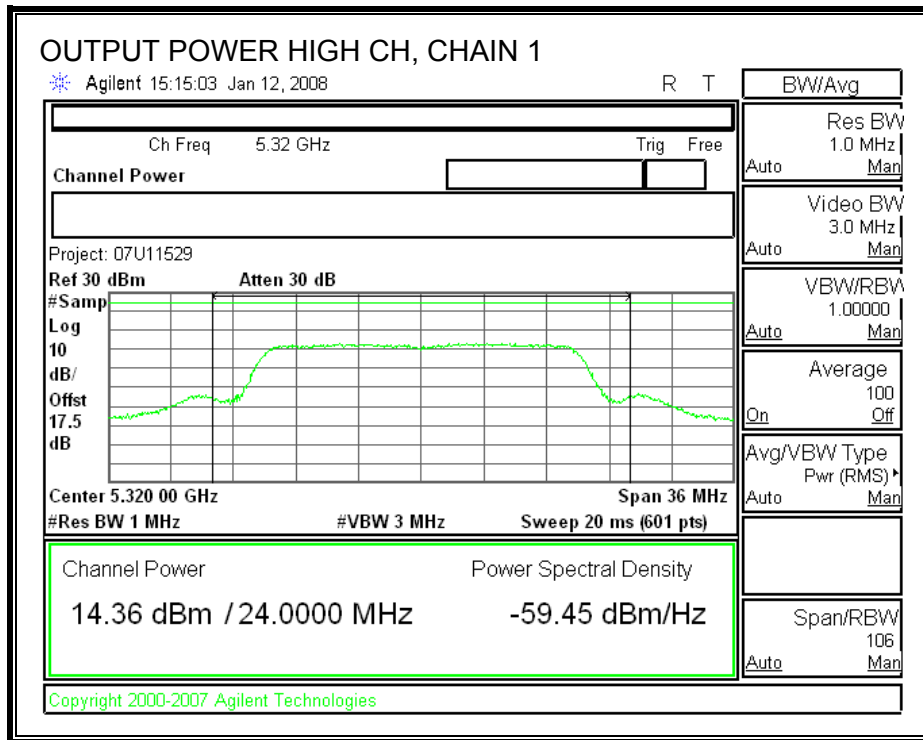

CHAIN 0 OUTPUT POWER (8.61 dBi Antenna Gain)

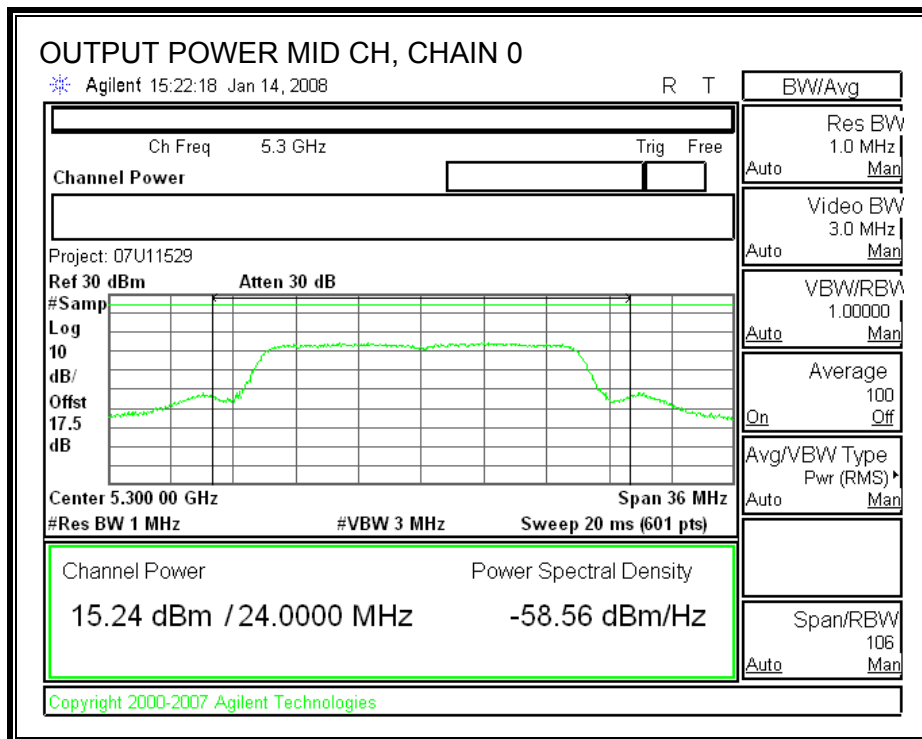
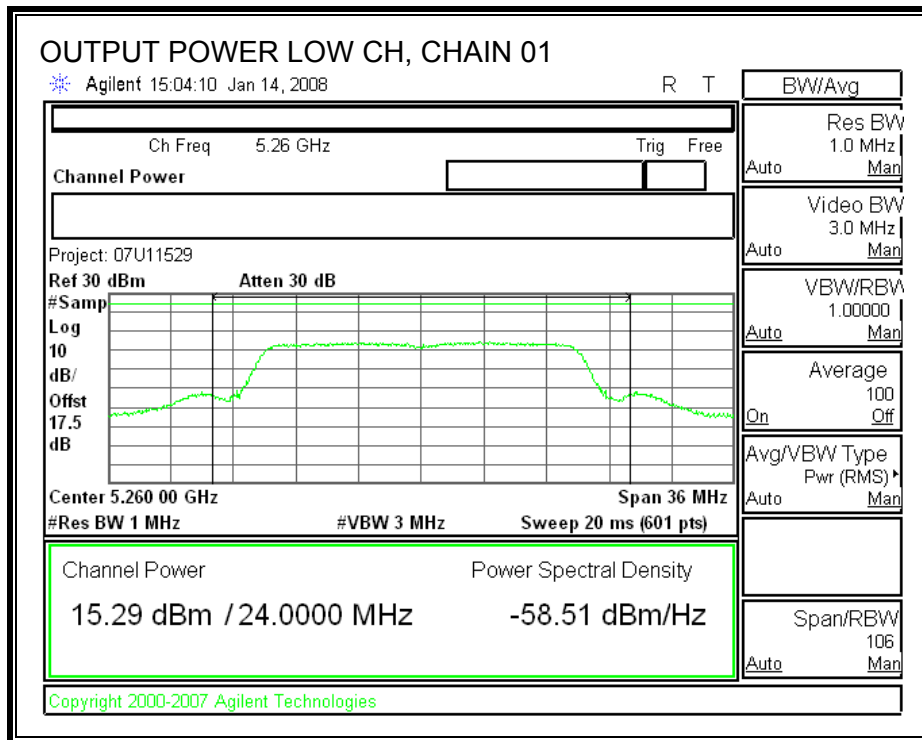

CHAIN 1 OUTPUT POWER (8.61 dBi Antenna Gain)

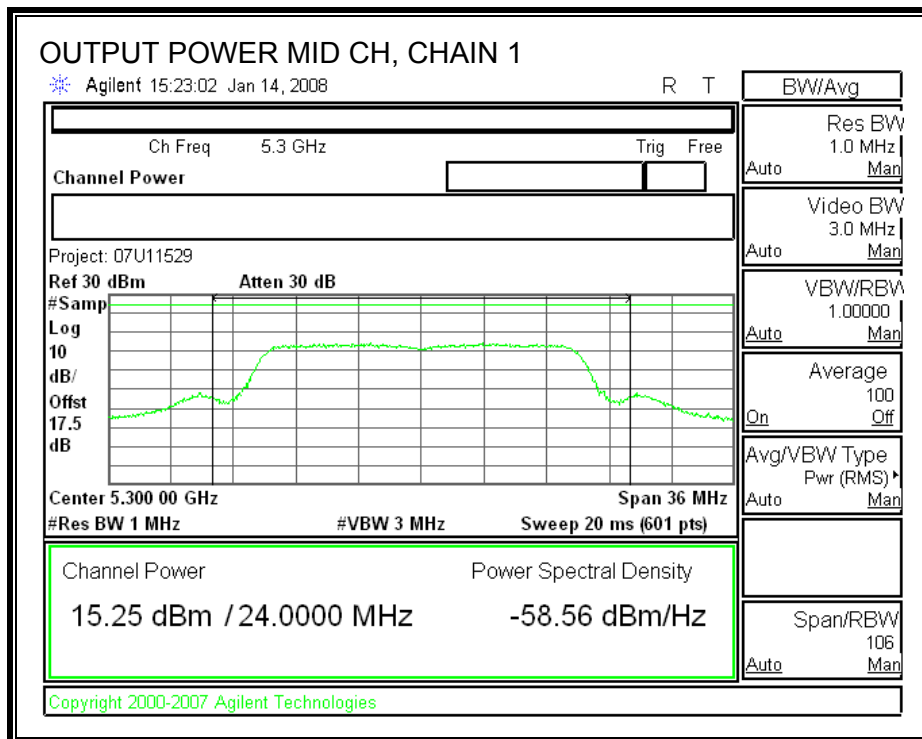
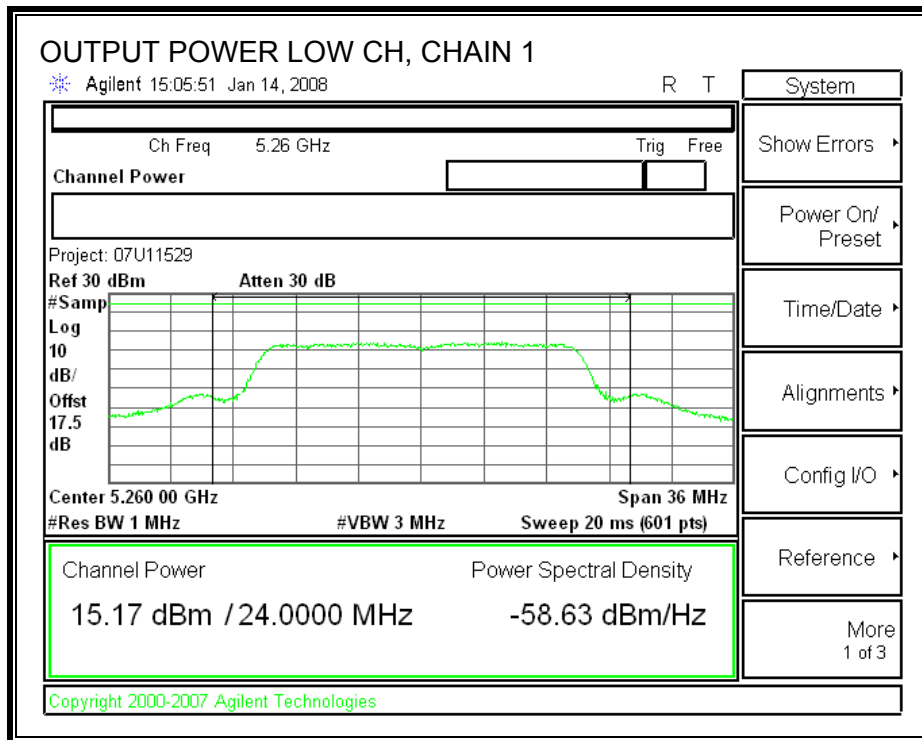

8.2.3. PEAK POWER SPECTRAL DENSITY

LIMITS

FCC §15.407 (a) (2)

IC RSS-210 A9.2 (2)

For the 5.25-5.35 GHz band, the peak power spectral density shall not exceed 11 dBm in any 1 MHz band. If transmitting antennas of directional gain greater than 6 dBi are used, both the peak transmit power and the peak power spectral density shall be reduced by the amount in dB that the directional gain of the antenna exceeds 6 dBi.

The maximum antenna gain is less than or equal to 6 dBi, therefore the limit is 11 dBm.

The maximum antenna gain is 8.61 dBi, therefore the limit is 8.39 dBm.

TEST PROCEDURE

The test is performed in accordance with FCC Public Notice: APPENDIX A Guidelines for Assessing Unlicensed National Information Infrastructure (U-NII) Devices – Part 15, Subpart E, August 2002. PPSD method #2 was used.

RESULTS

6d Bi Antenna Gain

Channel	Frequency (MHz)	PPSD With Combiner (dBm)	Limit (dBm)	Margin (dB)
Low	5260	9.328	11.00	-1.67
Middle	5300	9.345	11.00	-1.66
High	5320	7.200	11.00	-3.80

8.61d Bi Antenna Gain

Note: High channel still meets the PPSD limit of high antenna gain. It utilizes the same power level for all antennas; 8.61dBi data below only show differences for low and mid channels.

Channel	Frequency (MHz)	PPSD With Combiner (dBm)	Limit (dBm)	Margin (dB)
Low	5260	8.322	8.39	-0.07
Middle	5300	8.266	8.39	-0.12

POWER SPECTRAL DENSITY WITH COMBINER (6 dBi Antenna Gain)

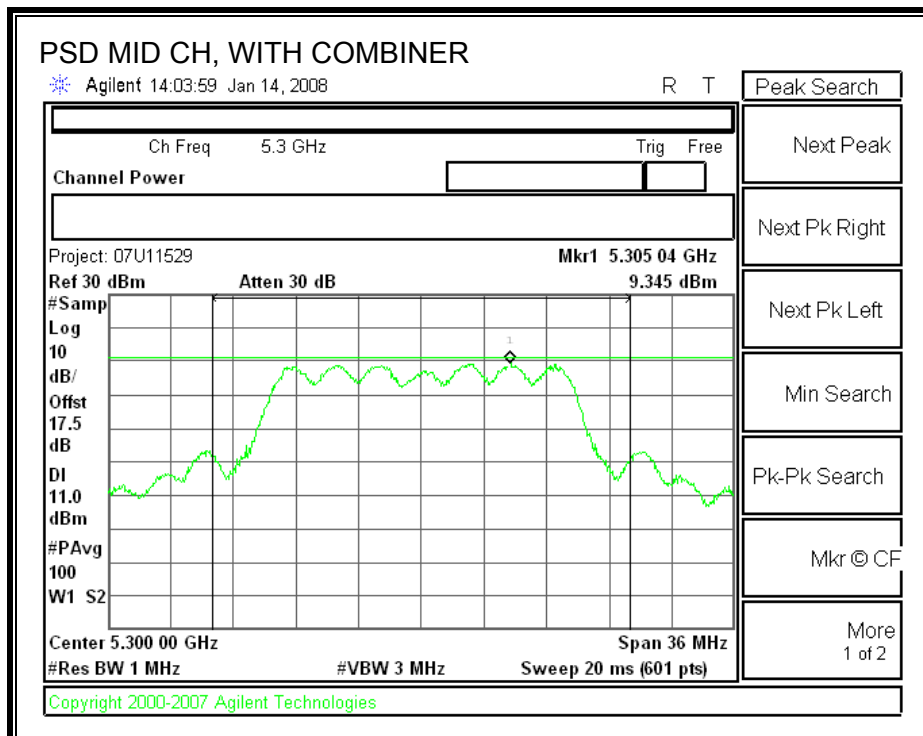
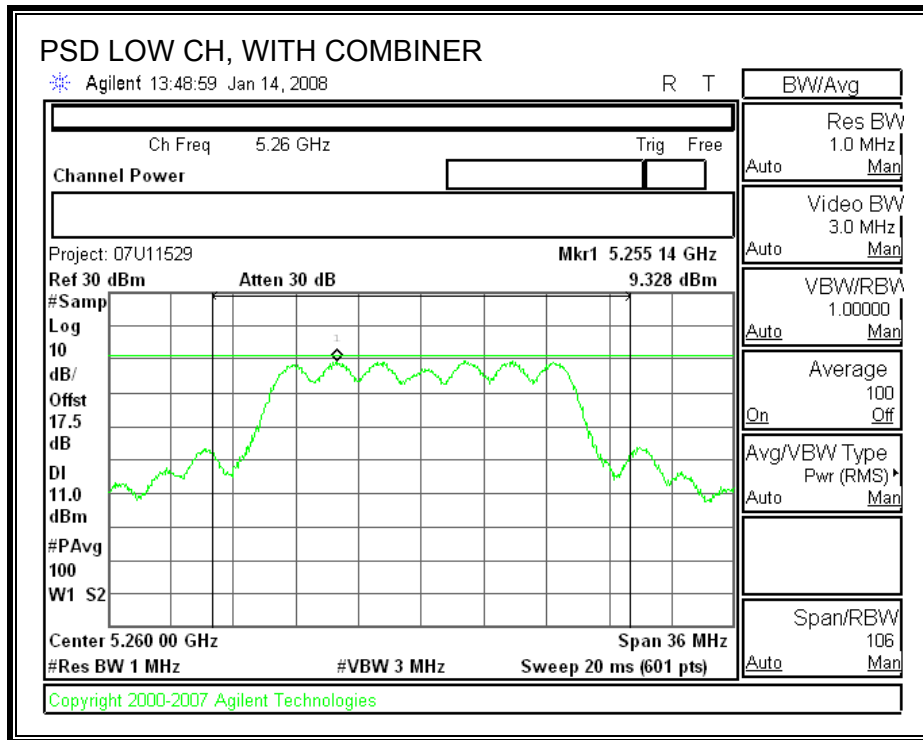

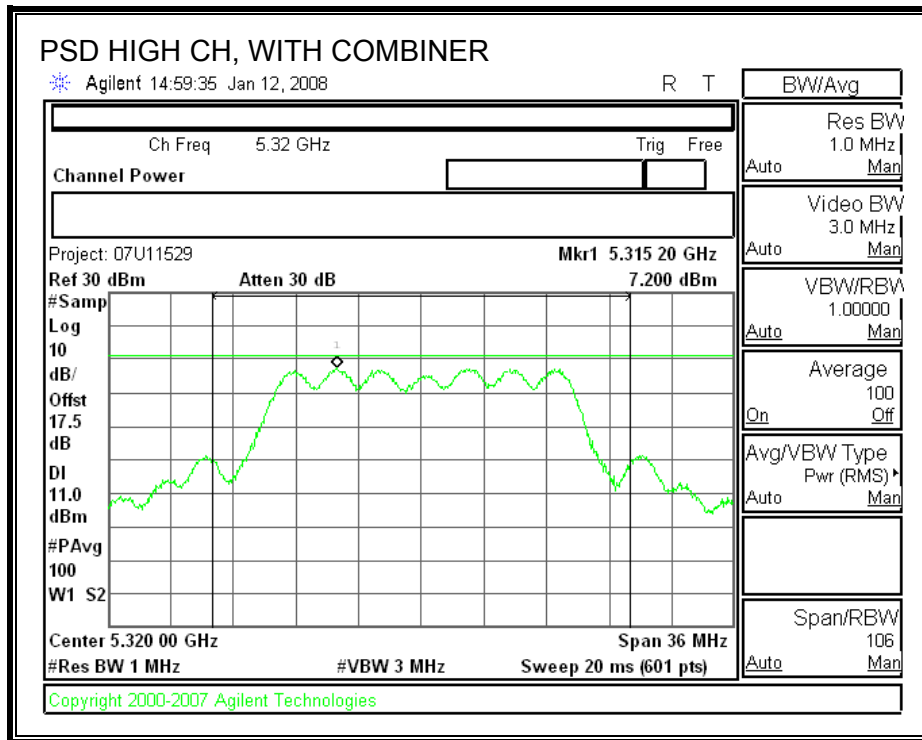

POWER SPECTRAL DENSITY WITH COMBINER (8.61 dBi Antenna Gain)

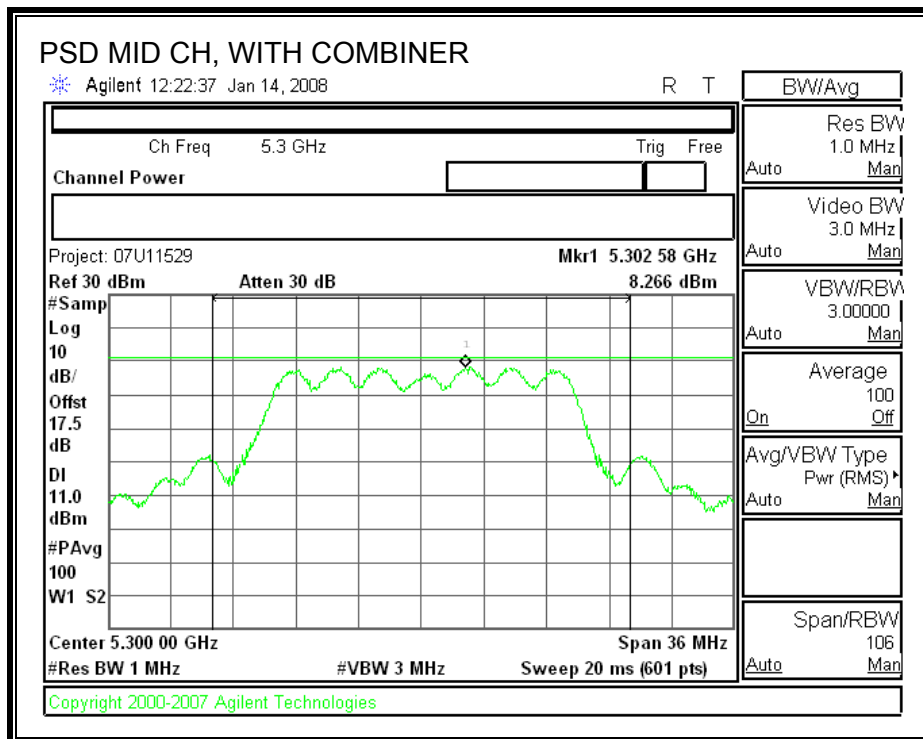
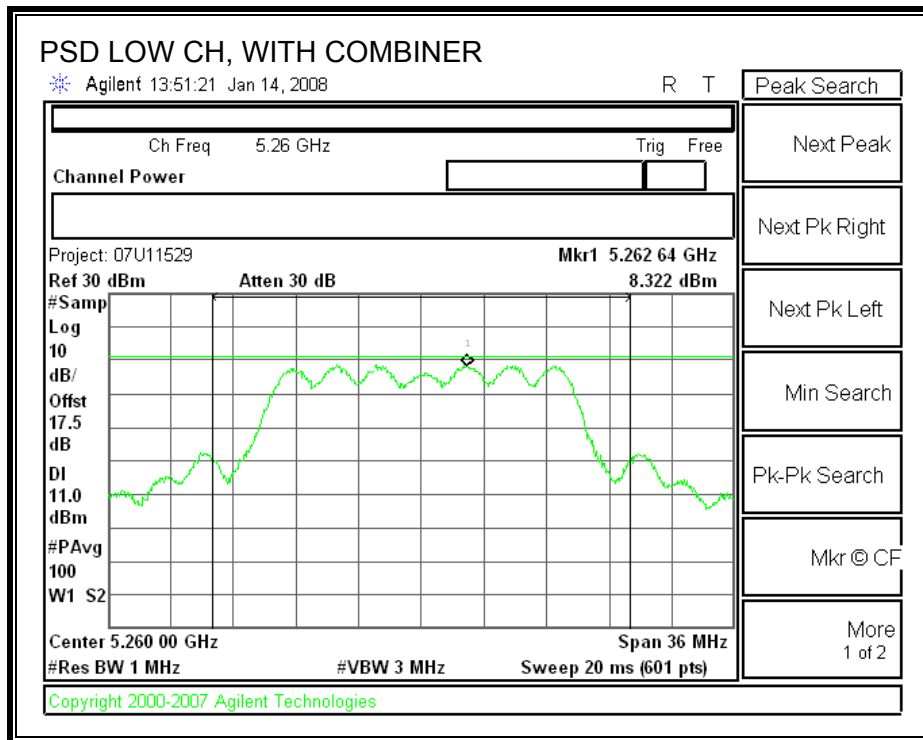

8.2.4. PEAK EXCURSION

LIMITS

FCC §15.407 (a) (6)

The ratio of the peak excursion of the modulation envelope (measured using a peak hold function) to the peak transmit power (measured as specified above) shall not exceed 13 dB across any 1 MHz bandwidth or the emission bandwidth whichever is less.

TEST PROCEDURE

The transmitter outputs are connected to the spectrum analyzer.

The test is performed in accordance with FCC Public Notice: APPENDIX A Guidelines for Assessing Unlicensed National Information Infrastructure (U-NII) Devices – Part 15, Subpart E, August 2002.

Since Method # 1 was used for peak power measurements, Method # 1 settings are used for the second PPSD trace.

RESULTS

Chain 1

Channel	Frequency (MHz)	Peak Excursion (dB)	Limit (dB)	Margin (dB)
Low	5260	8.93	13	-4.07
Middle	5300	9.90	13	-3.10
High	5320	11.24	13	-1.76

Chain 2

Channel	Frequency (MHz)	Peak Excursion (dB)	Limit (dB)	Margin (dB)
Low	5260	9.82	13	-3.18
Middle	5300	10.47	13	-2.53
High	5320	10.30	13	-2.70

PEAK EXCURSION (CHAIN 0)

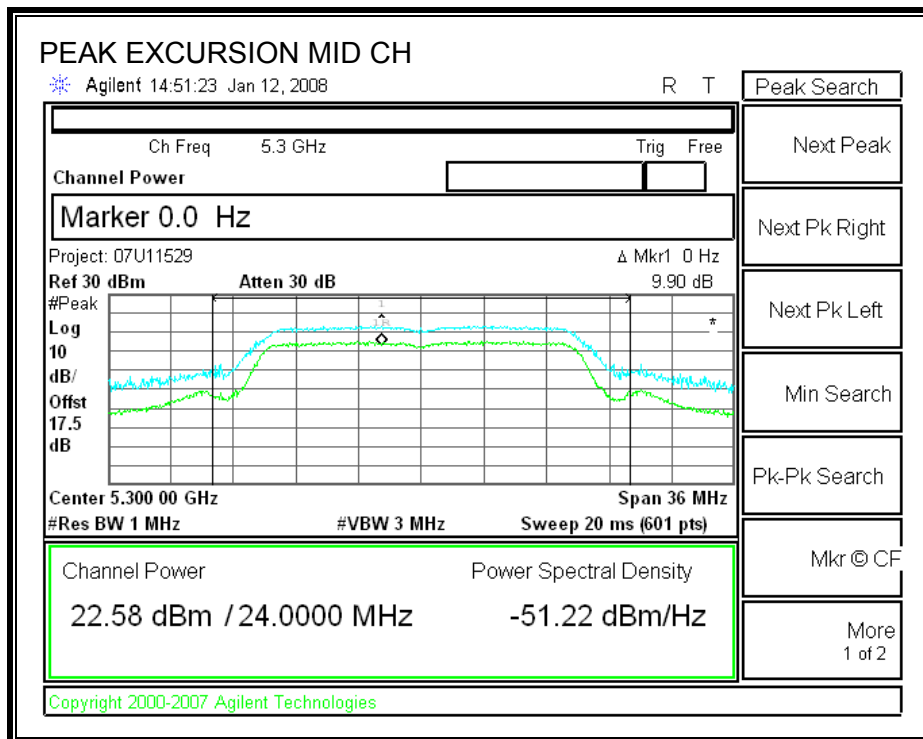
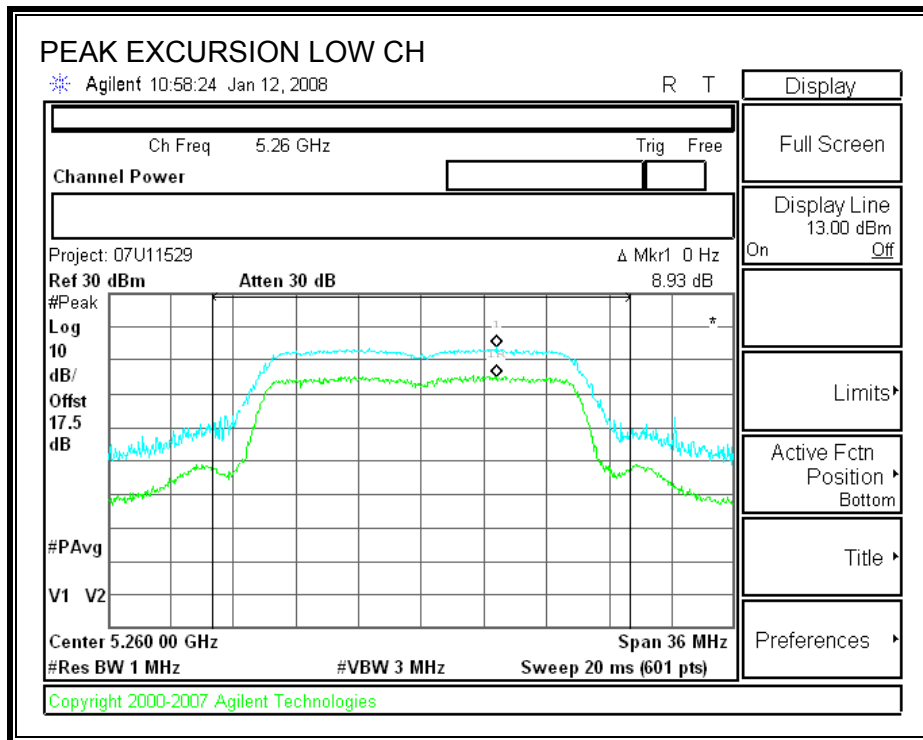

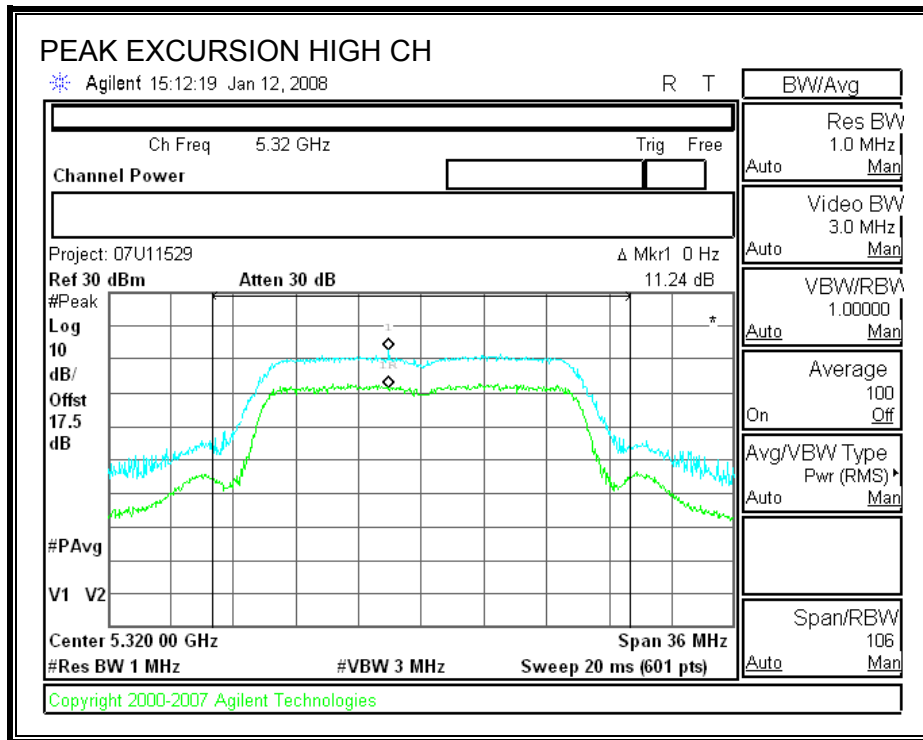

PEAK EXCURSION (CHAIN 1)

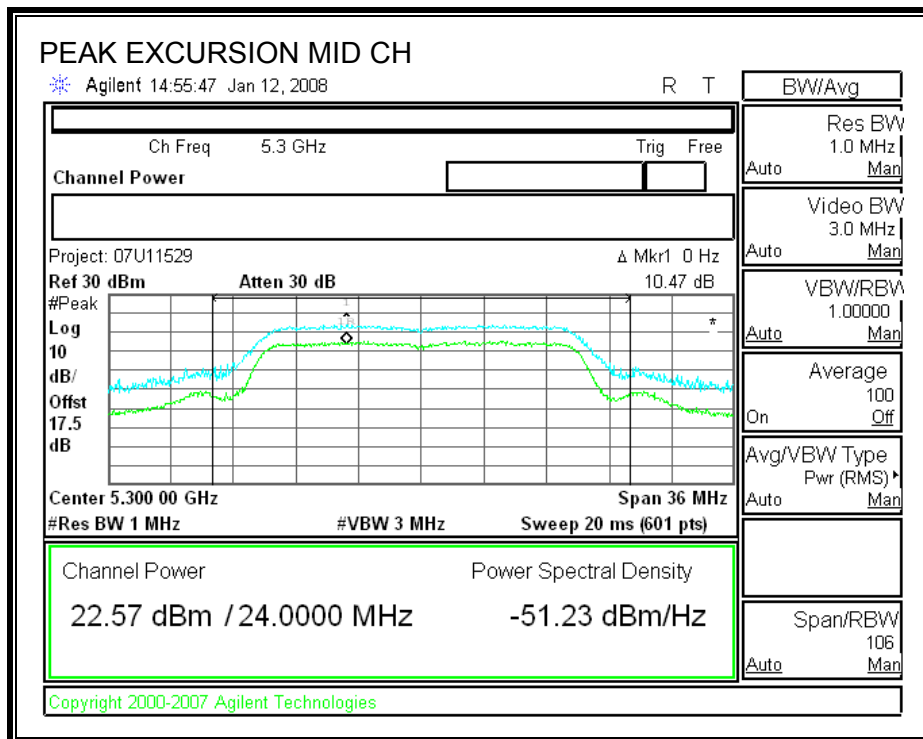
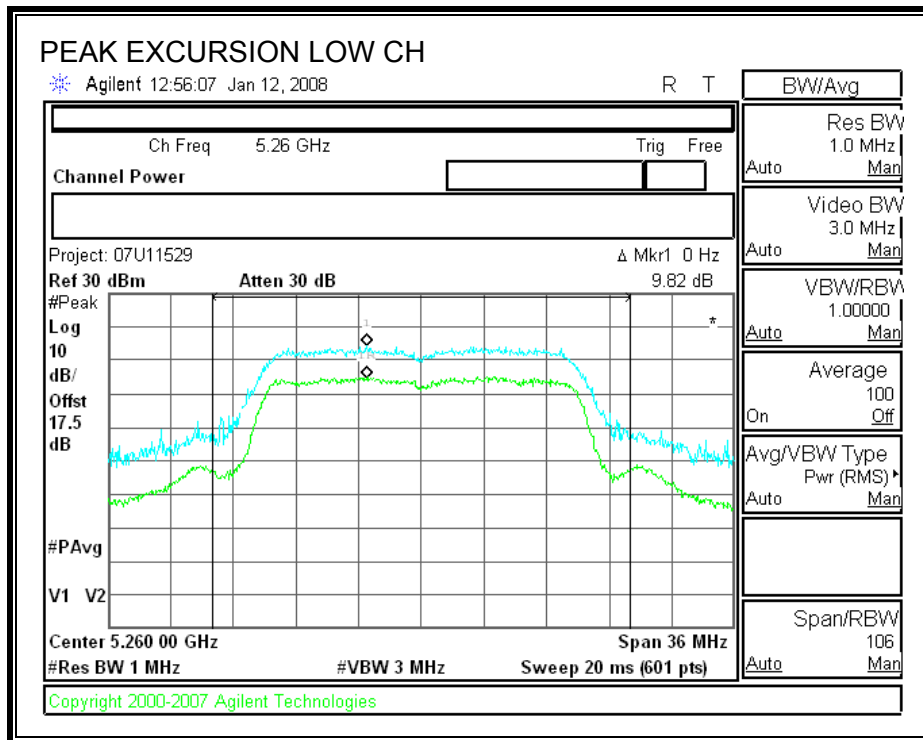

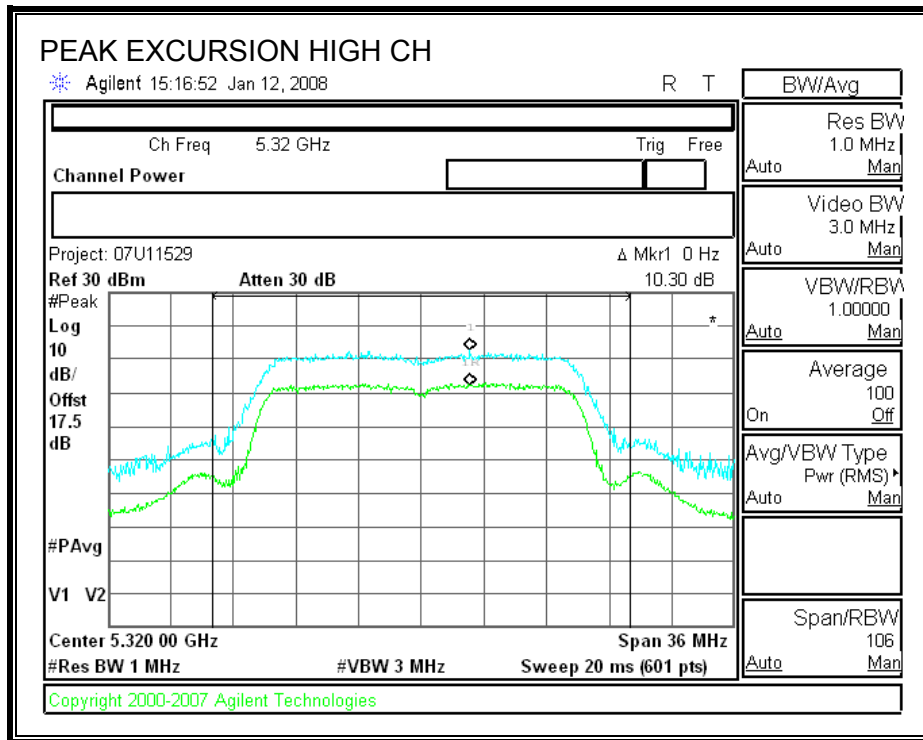

8.2.5. CONDUCTED SPURIOUS EMISSIONS

LIMITS

FCC §15.407 (b) (2)

IC RSS-210 A9.3 (2)

For transmitters operating in the 5.25-5.35 GHz band: all emissions outside of the 5.25-5.35 GHz band shall not exceed an EIRP of -27 dBm / MHz.

Devices operating in the 5.25-5.35 GHz band that generate emissions in the 5.15-5.25 GHz band must meet all applicable technical requirements for operation in the 5.15-5.25 GHz band (including indoor use) or alternatively meet an out-of-band emission EIRP limit of -27 dBm/MHz in the 5.15-5.25 GHz band.

Limit line = -27 - EUT Antenna Gain

TEST PROCEDURE

Conducted RF measurements of the transmitter output are made to confirm that the EUT antenna port conducted emissions meet the specified limit and to identify any spurious signals that require further investigation or measurements on the radiated emissions site.

The transmitter output is connected to the spectrum analyzer. The resolution bandwidth is set to 1 MHz. The video bandwidth is set to 1 MHz. Peak detection measurements are compared to the average EIRP limit, adjusted for the maximum antenna gain. If necessary, additional average detection measurements are made.

Measurements are made over the 30 MHz to 40 GHz range with the transmitter set to the lowest, middle, and highest channels.

RESULTS

SPURIOUS EMISSIONS WITH COMBINER

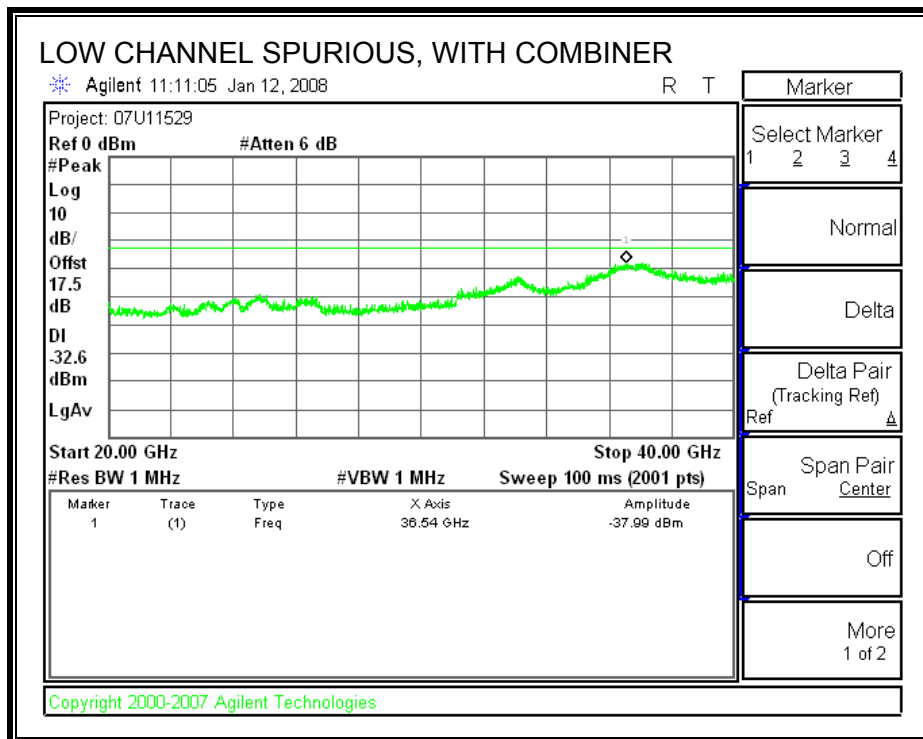
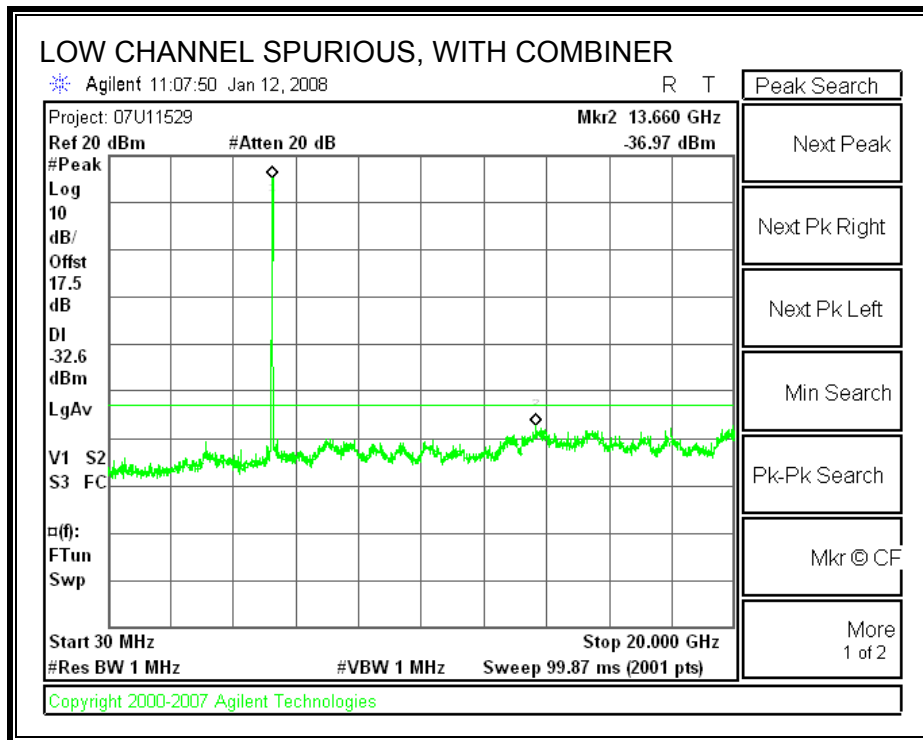

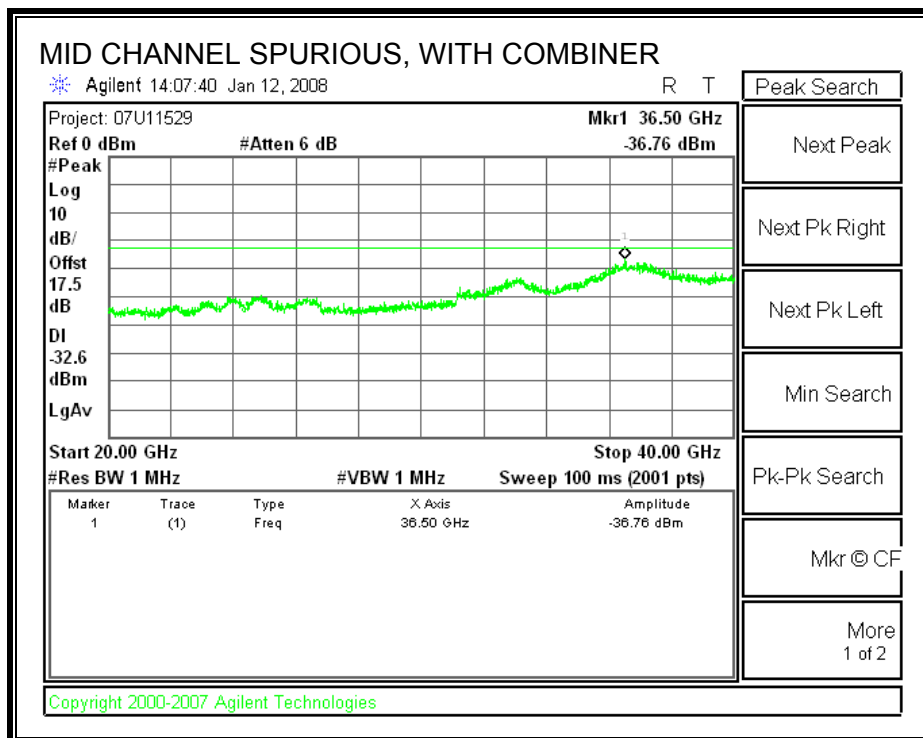
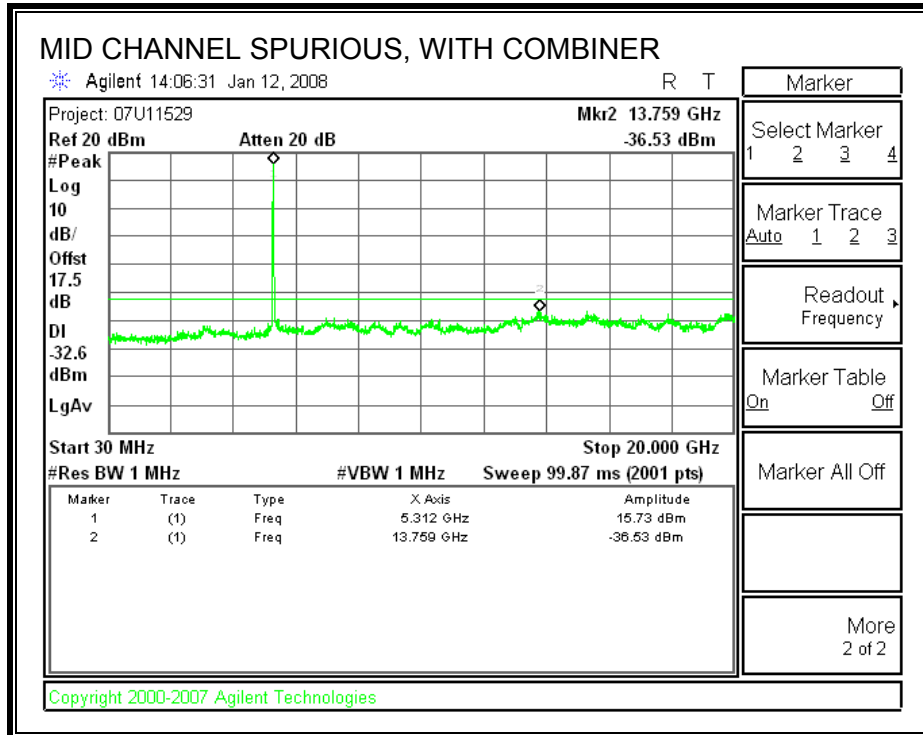

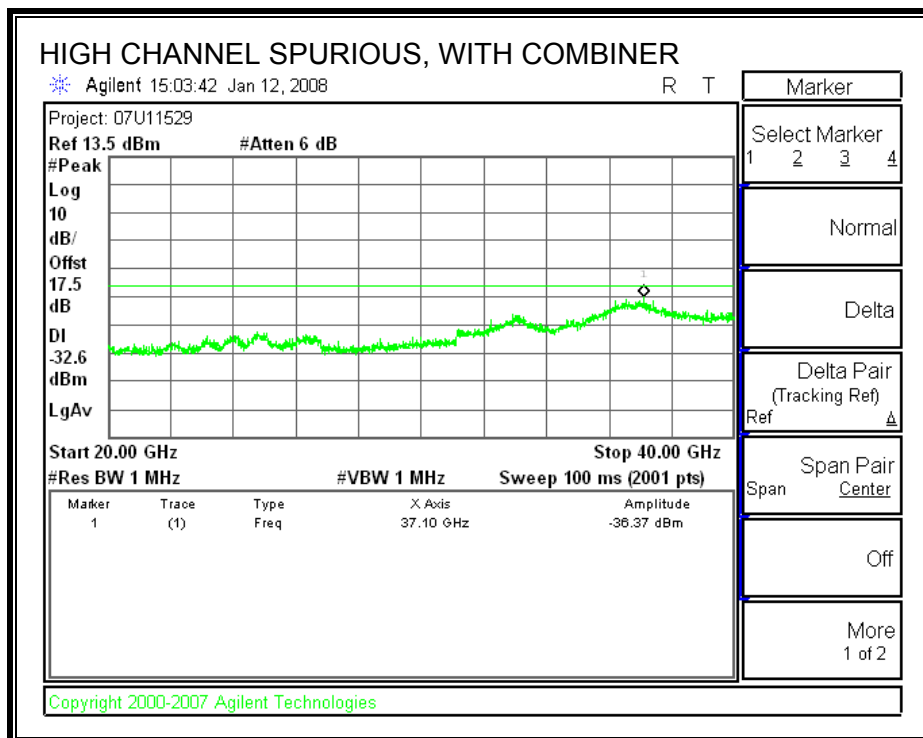
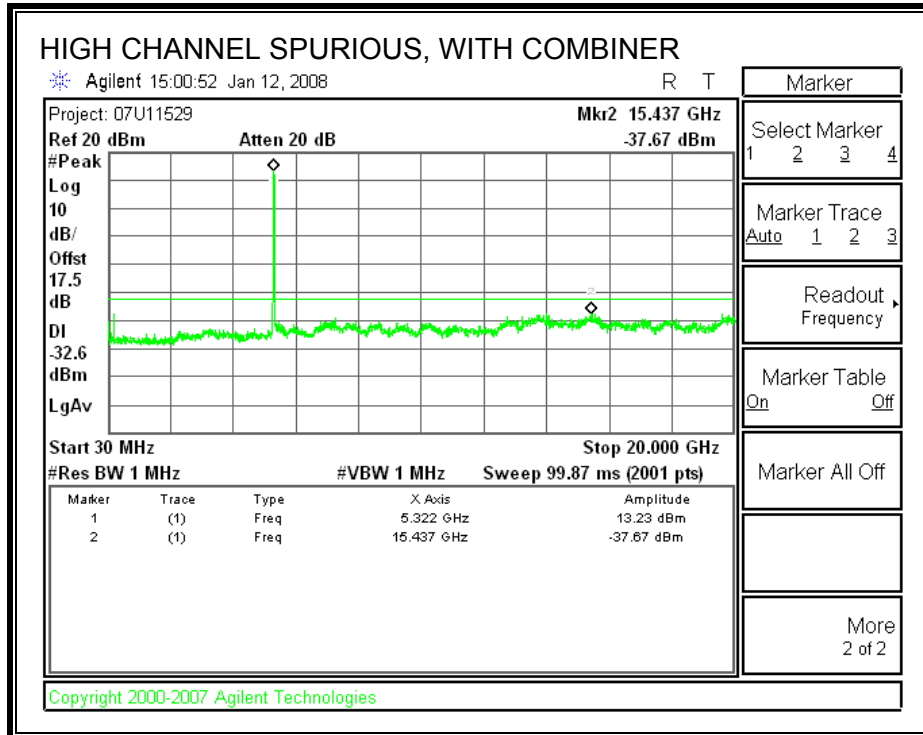

8.3. 802.11n HT40 MODE

8.3.1. 26 dB and 99% BANDWIDTH

LIMITS

None; for reporting purposes only.

TEST PROCEDURE

The transmitter outputs are connected to the spectrum analyzer via a combiner. The RBW is set to 1% to 3% of the measured bandwidth. The VBW is set to 3 times the RBW. The sweep time is coupled. The spectrum analyzer internal bandwidth function is utilized.

RESULTS

Channel	Frequency (MHz)	26 dB Bandwidth (MHz)	99% Bandwidth (MHz)
Middle	5270	38.728	36.2103
High	5310	38.540	36.1414

26 dB and 99% BANDWIDTH

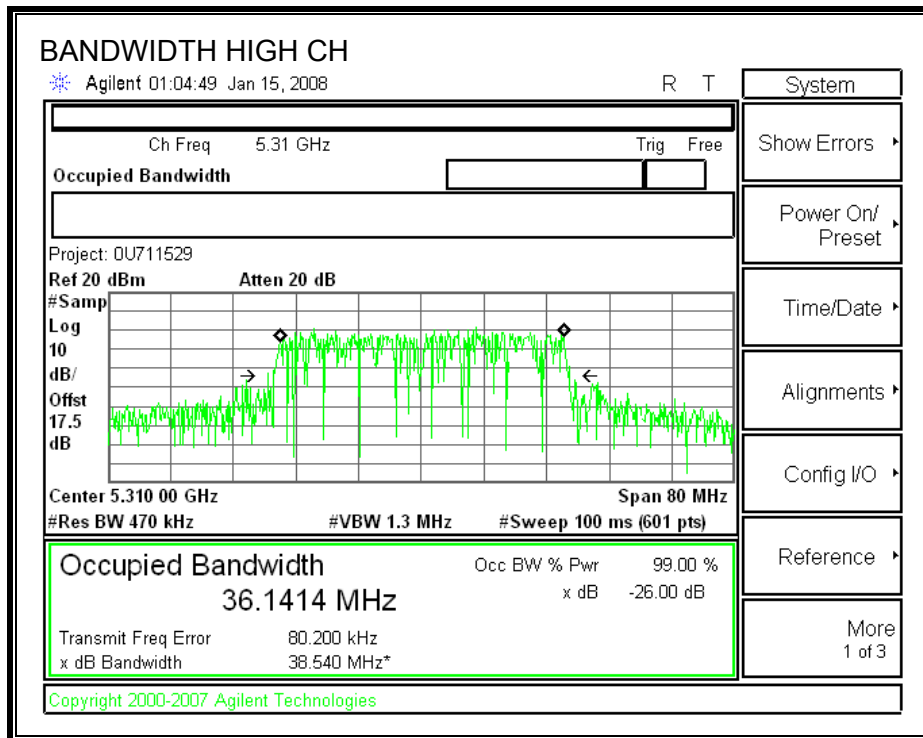
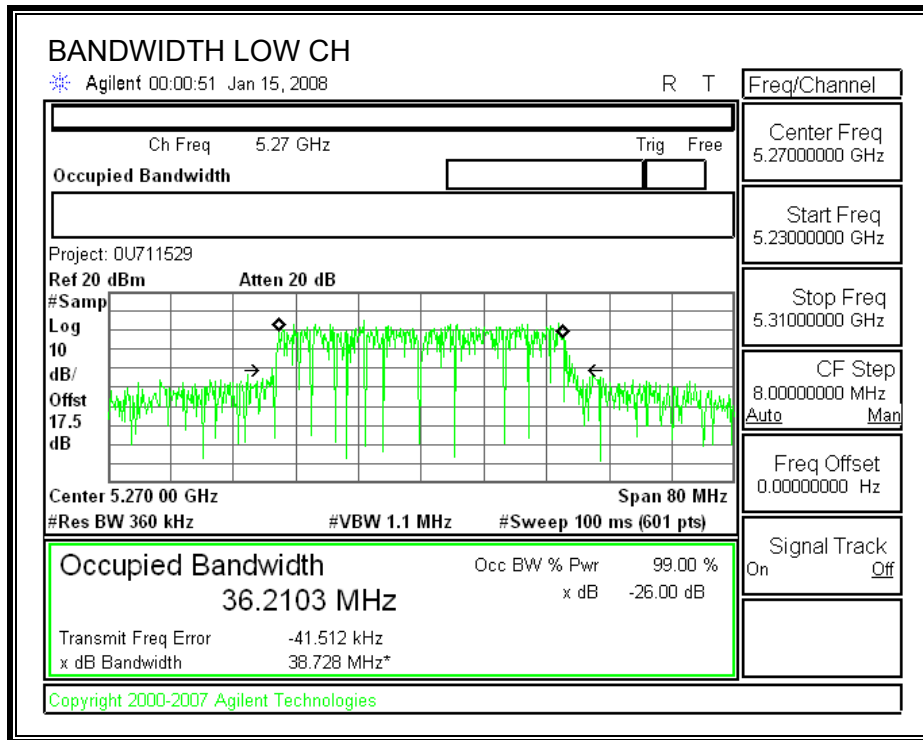

8.3.2. OUTPUT POWER

LIMITS

FCC §15.407 (a) (2)

IC RSS-210 A9.2 (2)

For the 5.25-5.35 GHz band, the maximum conducted output power over the frequency band of operation shall not exceed the lesser of 250 mW or $11 \text{ dBm} + 10 \log B$, where B is the 26-dB emission bandwidth in MHz. If transmitting antennas of directional gain greater than 6 dBi are used, both the peak transmit power and the peak power spectral density shall be reduced by the amount in dB that the directional gain of the antenna exceeds 6 dBi.

TEST PROCEDURE

The test is performed in accordance with FCC Public Notice: APPENDIX A Guidelines for Assessing Unlicensed National Information Infrastructure (U-NII) Devices – Part 15, Subpart E, August 2002.

The transmitter output operates continuously therefore Method # 1 is used.

RESULTS

6dBi Antenna Gain

Limit

Channel	Frequency (MHz)	Fixed Limit (dBm)	B (MHz)	11 + 10 Log B Limit (dBm)	Antenna Gain (dBi)	Limit (dBm)
Low	5270	24	38.728	26.88	6.00	24.00
High	5310	24	38.540	26.86	6.00	24.00

Individual Chain Results

Channel	Frequency (MHz)	Chain 0 Power (dBm)	Chain 1 Power (dBm)	Total Power (dBm)	Limit (dBm)	Margin (dB)
Low	5270	17.19	17.28	20.25	24.00	-3.75
High	5310	12.51	12.73	15.63	24.00	-8.37

8.61dBi Antenna Gain

Low & high channels still meet the Peak Power and PPSD limits of high antenna gain. These channels utilize the same power level for all antennas. The channel power data in table below is from 6dBi data.

Limit

Channel	Frequency (MHz)	Fixed Limit (dBm)	B (MHz)	11 + 10 Log B Limit (dBm)	Antenna Gain (dBi)	Limit (dBm)
Low	5270	24	38.728	26.88	8.61	21.39
High	5310	24	38.540	26.86	8.61	21.39

Individual Chain Results

Channel	Frequency (MHz)	Chain 1 Power (dBm)	Chain 2 Power (dBm)	Total Power (dBm)	Limit (dBm)	Margin (dB)
Low	5270	17.19	17.28	20.25	21.39	-1.14
High	5310	12.51	12.73	15.63	21.39	-5.76

CHAIN 0 OUTPUT POWER (6dBi & 8.61dBi Antenna Gains)

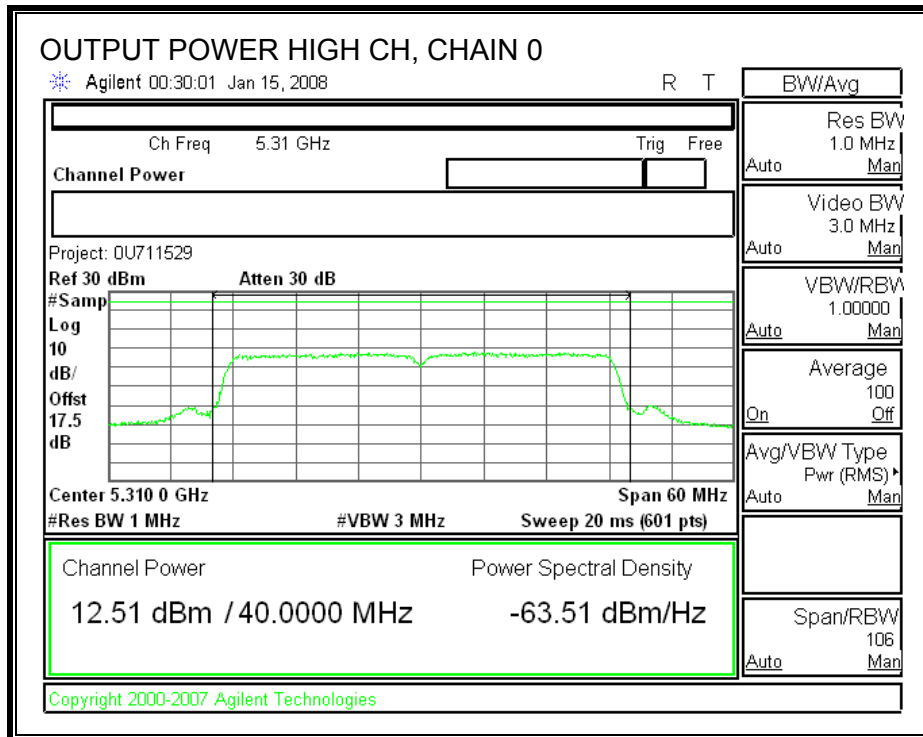
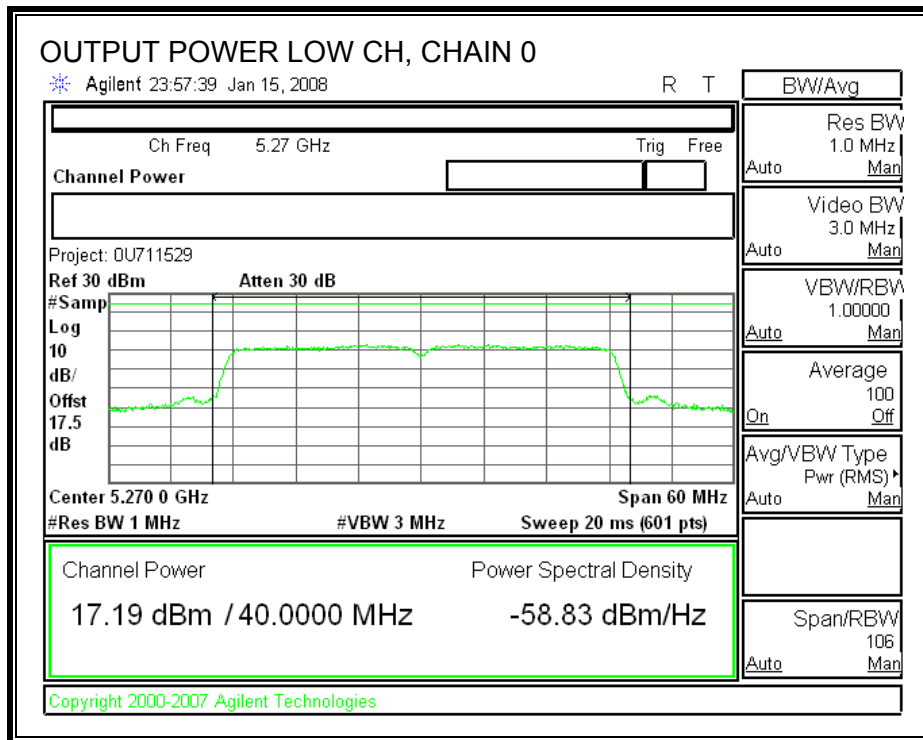

CHAIN 1 OUTPUT POWER (6dBi & 8.61dBi Antenna Gains)

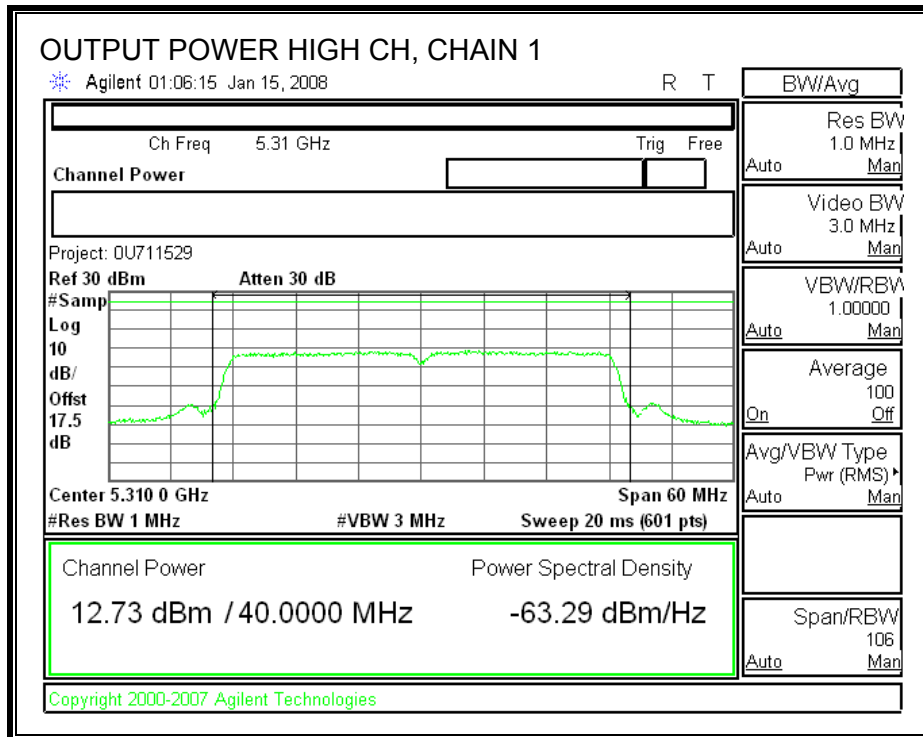
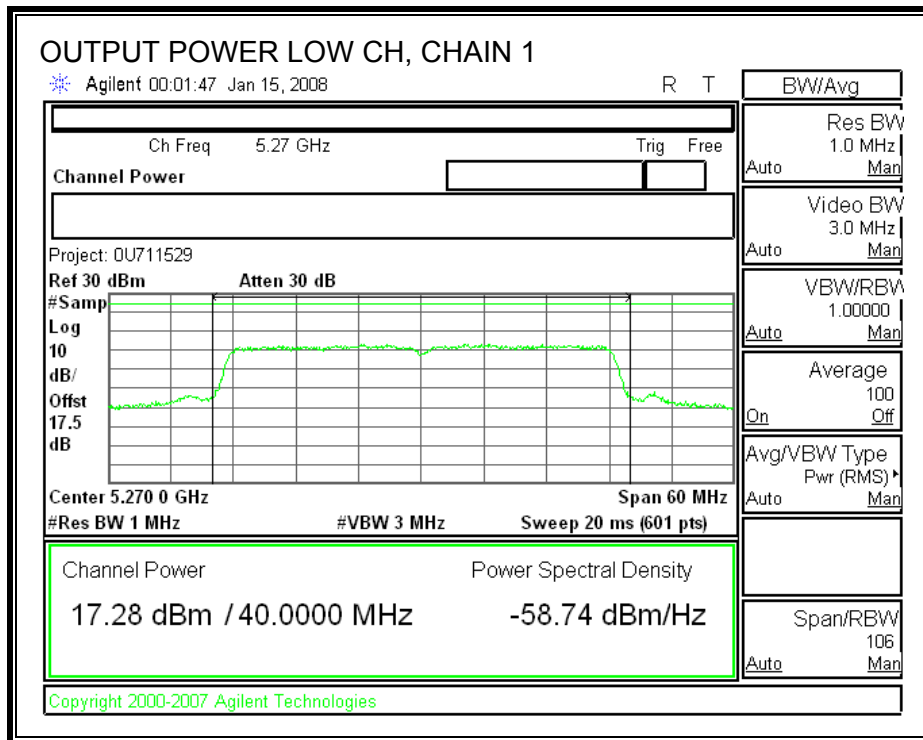

8.3.3. PEAK POWER SPECTRAL DENSITY

LIMITS

FCC §15.407 (a) (2)

IC RSS-210 A9.2 (2)

For the 5.25-5.35 GHz band, the peak power spectral density shall not exceed 11 dBm in any 1 MHz band. If transmitting antennas of directional gain greater than 6 dBi are used, both the peak transmit power and the peak power spectral density shall be reduced by the amount in dB that the directional gain of the antenna exceeds 6 dBi.

The maximum antenna gain is less than or equal to 6 dBi, therefore the limit is 11 dBm.

The maximum antenna gain is 8.61 dBi, therefore the limit is 8.39 dBm.

TEST PROCEDURE

The test is performed in accordance with FCC Public Notice: APPENDIX A Guidelines for Assessing Unlicensed National Information Infrastructure (U-NII) Devices – Part 15, Subpart E, August 2002. PPSD method #2 was used.

RESULTS

6dBi Antenna Gain

Channel	Frequency (MHz)	PPSD With Combiner (dBm)	Limit (dBm)	Margin (dB)
Low	5270	7.486	11	-3.51
High	5310	3.050	11	-7.95

8.61dBi Antenna Gain

Low & high channels still meet the PPSD limit of high antenna gain. These channels utilize the same power level for all antennas, 8.61dBi data in table below is from 6dBi data.

Channel	Frequency (MHz)	PPSD With Combiner (dBm)	Limit (dBm)	Margin (dB)
Low	5270	7.486	8.39	-0.90
High	5310	3.050	8.39	-5.34

POWER SPECTRAL DENSITY WITH COMBINER (6dBi & 8.61dBi Antenna Gains)

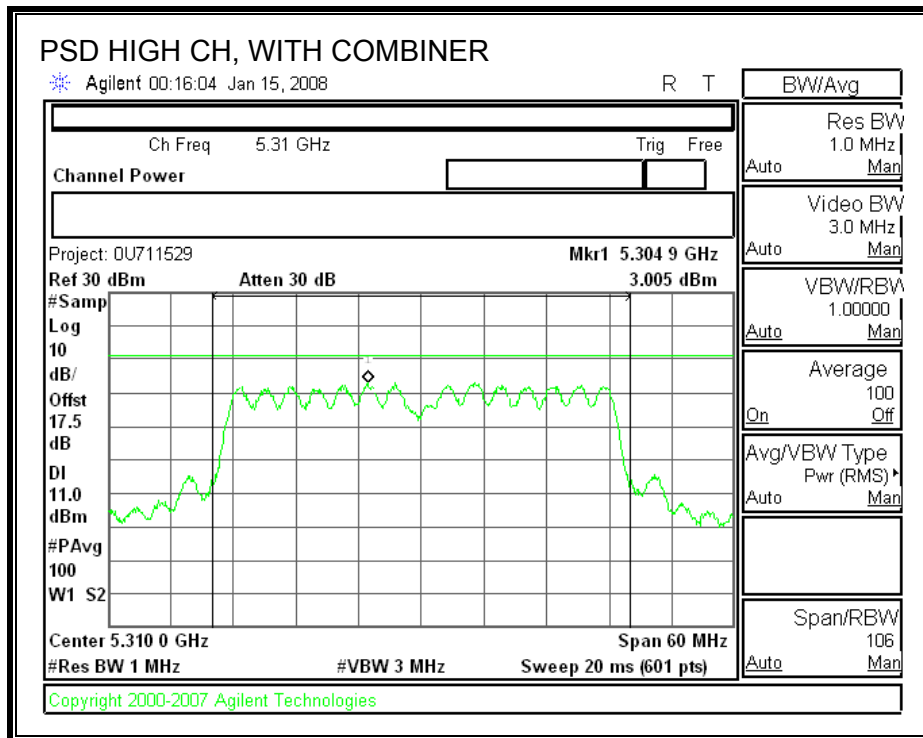
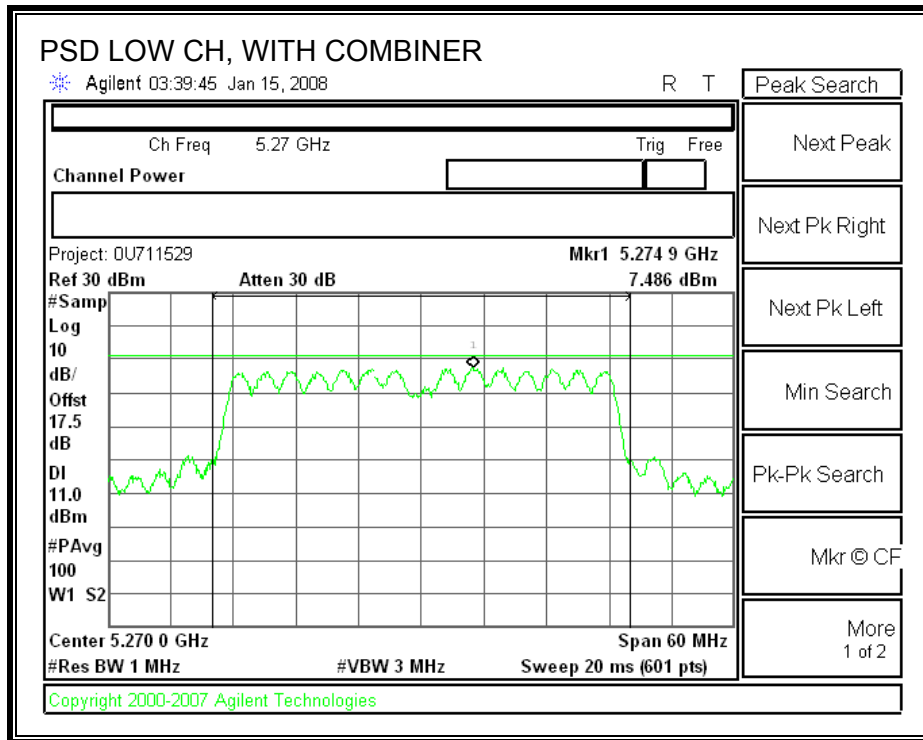

8.3.4. PEAK EXCURSION

LIMITS

FCC §15.407 (a) (6)

The ratio of the peak excursion of the modulation envelope (measured using a peak hold function) to the peak transmit power (measured as specified above) shall not exceed 13 dB across any 1 MHz bandwidth or the emission bandwidth whichever is less.

TEST PROCEDURE

The transmitter outputs are connected to the spectrum analyzer via a combiner.

The test is performed in accordance with FCC Public Notice: APPENDIX A Guidelines for Assessing Unlicensed National Information Infrastructure (U-NII) Devices – Part 15, Subpart E, August 2002.

Since Method # 1 was used for peak power measurements, Method # 1 settings are used for the second PPSD trace.

RESULTS

CHAIN 1

Channel	Frequency (MHz)	Peak Excursion (dB)	Limit (dB)	Margin (dB)
Low	5270	11.97	13	-1.03
High	5310	10.91	13	-2.09

CHAIN 2

Channel	Frequency (MHz)	Peak Excursion (dB)	Limit (dB)	Margin (dB)
Low	5270	11.00	13	-2.00
High	5310	10.42	13	-2.58

PEAK EXCURSION (CHAIN 0)

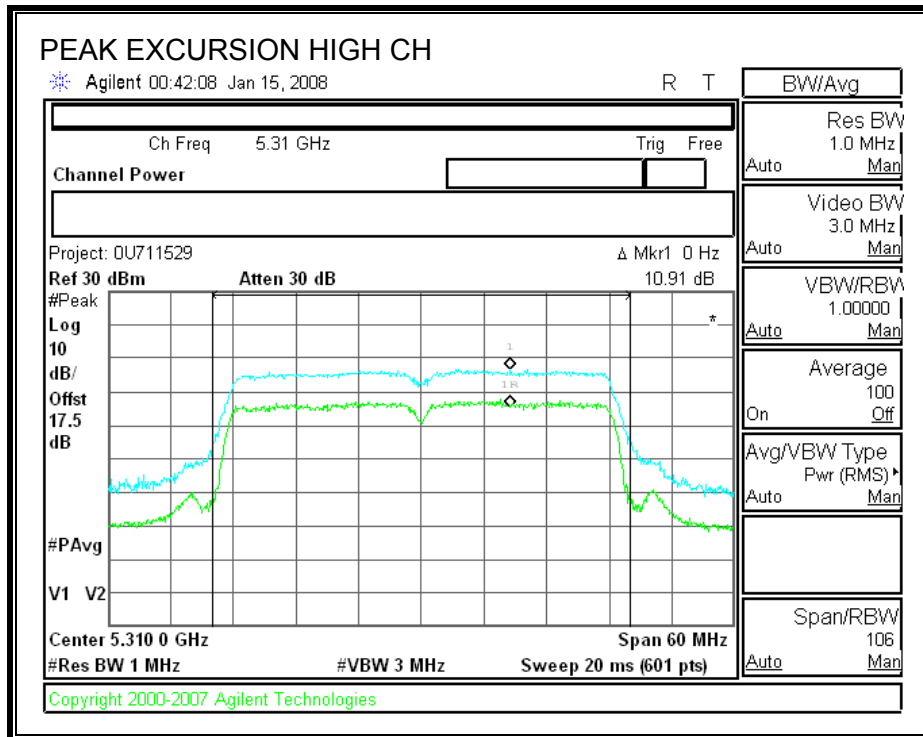
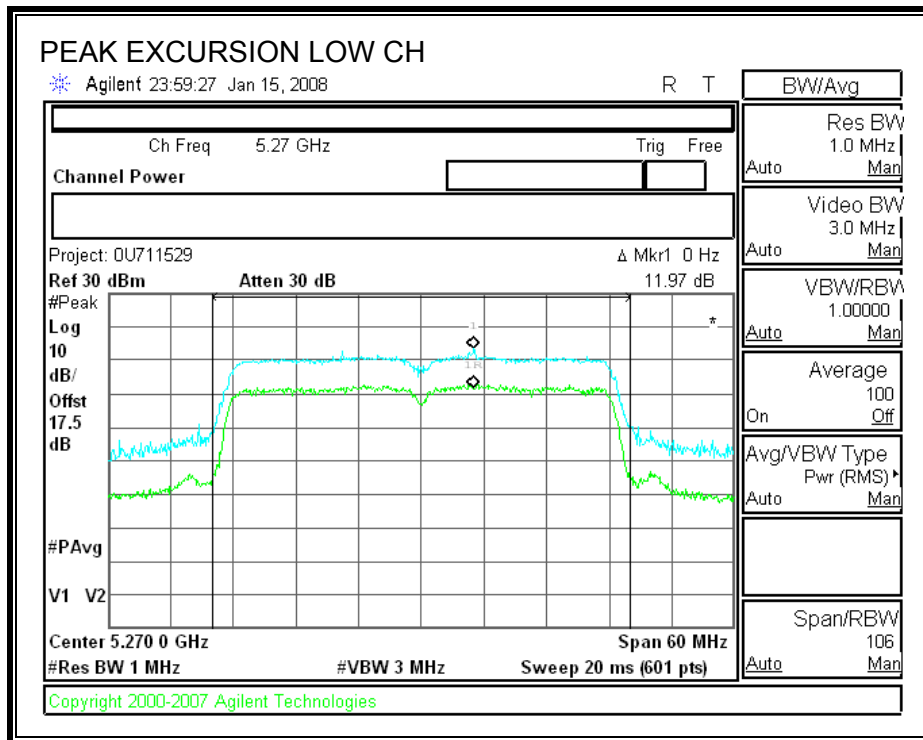

PEAK EXCURSION (CHAIN 1)

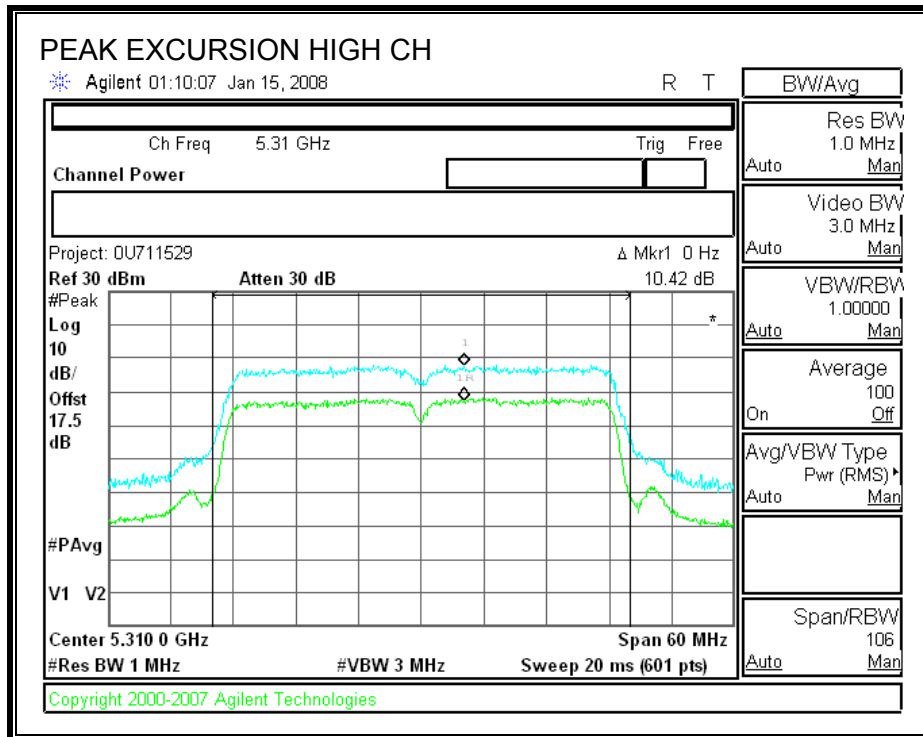
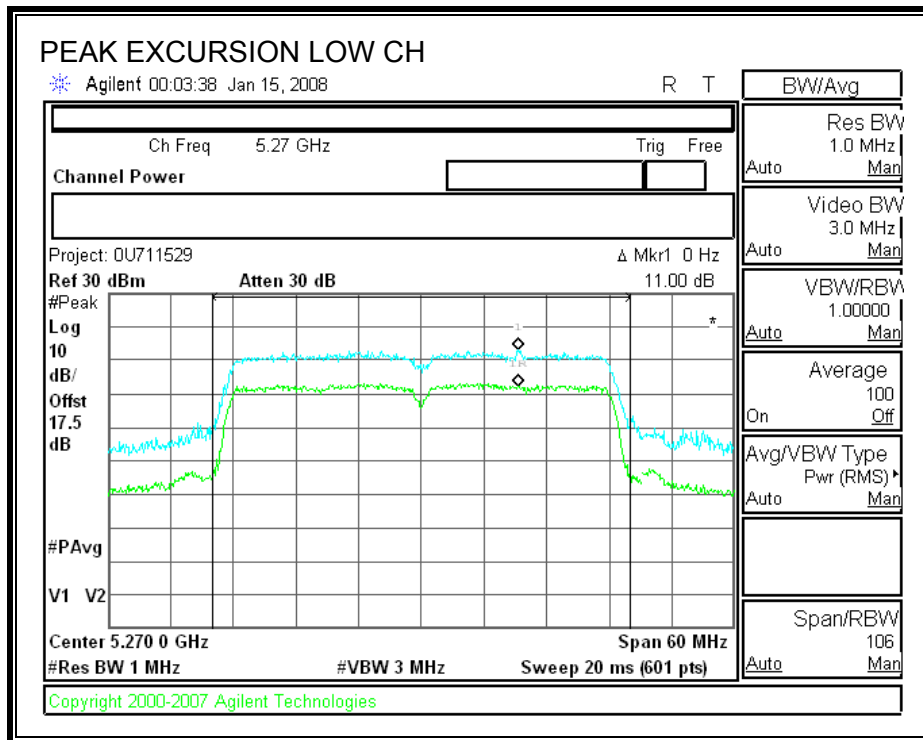

8.3.5. CONDUCTED SPURIOUS EMISSIONS

LIMITS

FCC §15.407 (b) (2)

IC RSS-210 A9.3 (2)

For transmitters operating in the 5.25-5.35 GHz band: all emissions outside of the 5.25-5.35 GHz band shall not exceed an EIRP of -27 dBm / MHz.

Devices operating in the 5.25-5.35 GHz band that generate emissions in the 5.15-5.25 GHz band must meet all applicable technical requirements for operation in the 5.15-5.25 GHz band (including indoor use) or alternatively meet an out-of-band emission EIRP limit of -27 dBm/MHz in the 5.15-5.25 GHz band.

Limit line = -27 - EUT Antenna Gain

TEST PROCEDURE

Conducted RF measurements of the transmitter output are made to confirm that the EUT antenna port conducted emissions meet the specified limit and to identify any spurious signals that require further investigation or measurements on the radiated emissions site.

The transmitter output is connected to the spectrum analyzer. The resolution bandwidth is set to 1 MHz. The video bandwidth is set to 1 MHz. Peak detection measurements are compared to the average EIRP limit, adjusted for the maximum antenna gain. If necessary, additional average detection measurements are made.

Measurements are made over the 30 MHz to 40 GHz range with the transmitter set to the lowest, middle, and highest channels.

RESULTS

SPURIOUS EMISSIONS WITH COMBINER

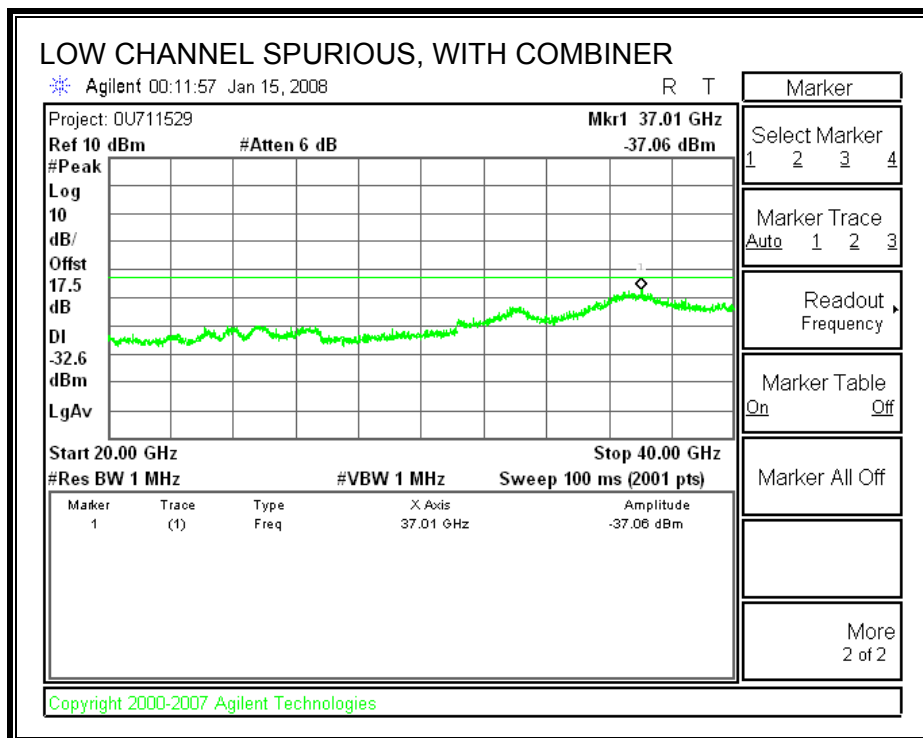
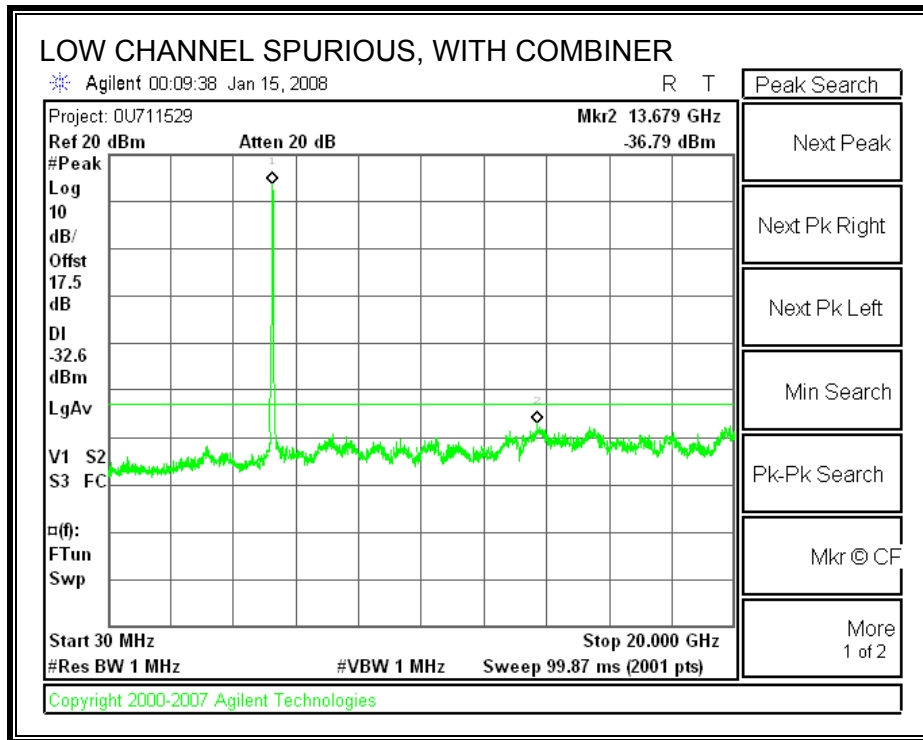

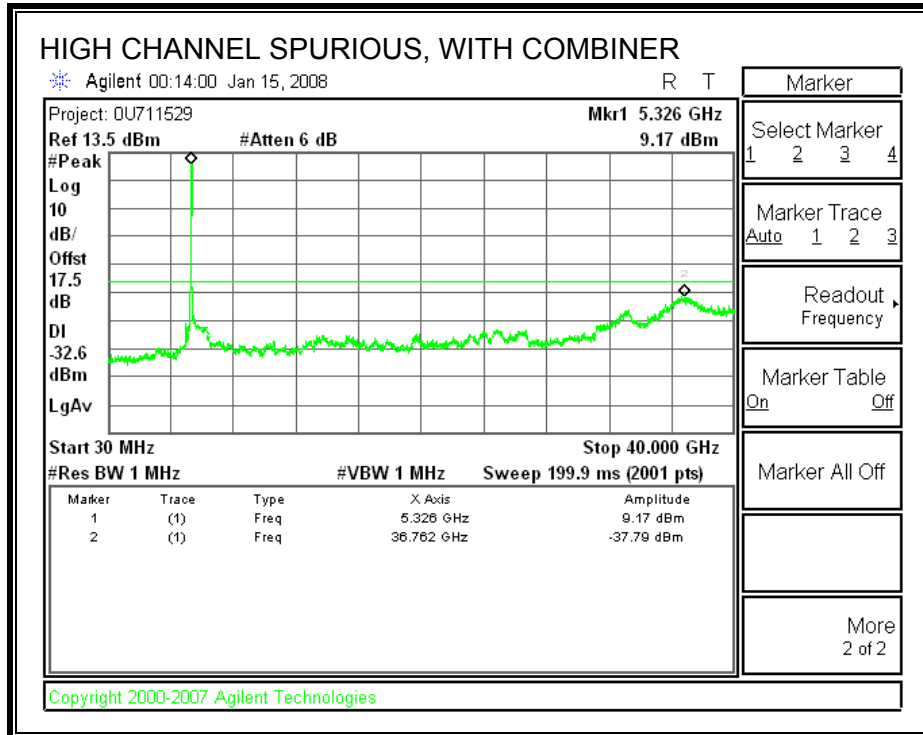

9. ANTENNA PORT TEST RESULTS FOR THE BAND 5.47–5.725 GHZ

9.1. 802.11a MODE

9.1.1. 26 dB and 99% BANDWIDTH

LIMITS

None; for reporting purposes only.

TEST PROCEDURE

The transmitter output is connected to the spectrum analyzer. The RBW is set to 1% to 3% of the measured bandwidth. The VBW is set to 3 times the RBW. The sweep time is coupled. The spectrum analyzer internal bandwidth function is utilized.

RESULTS

Frequency (MHz)	26 dB Bandwidth (MHz)	99% Bandwidth (MHz)
5500	19.221	16.6231
5600	23.467	16.6043
5700	27.564	16.9636

26 dB and 99% BANDWIDTH

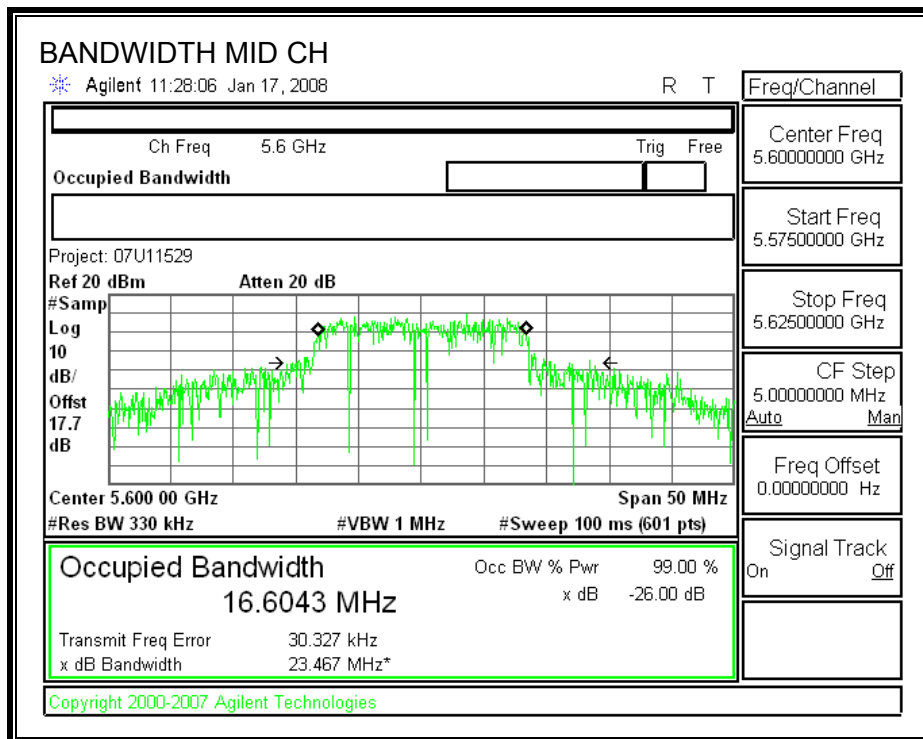
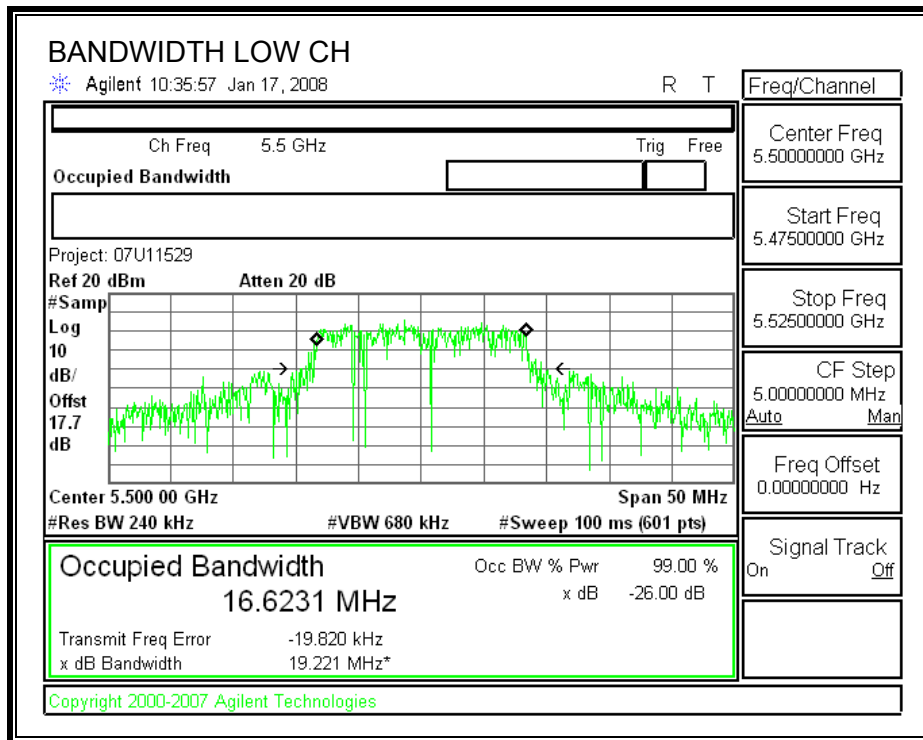

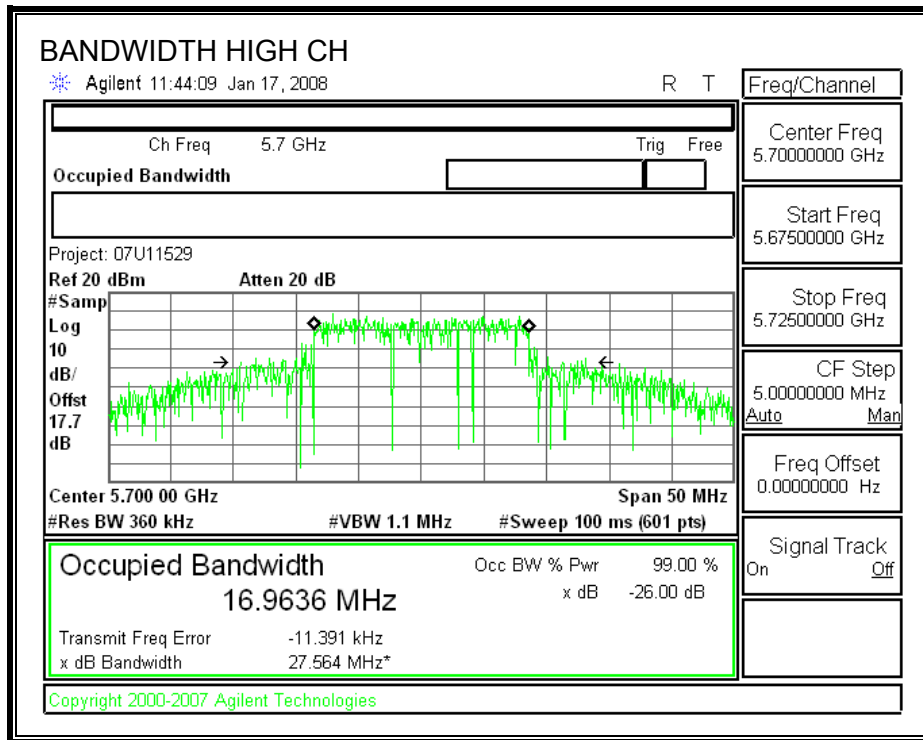

9.1.2. OUTPUT POWER

LIMITS

FCC §15.407 (a) (2)

IC RSS-210 A9.2 (2)

For the 5.47-5.725 GHz band, the maximum conducted output power over the frequency band of operation shall not exceed the lesser of 250 mW or $11 \text{ dBm} + 10 \log B$, where B is the 26-dB emission bandwidth in MHz. If transmitting antennas of directional gain greater than 6 dBi are used, both the peak transmit power and the peak power spectral density shall be reduced by the amount in dB that the directional gain of the antenna exceeds 6 dBi.

TEST PROCEDURE

The test is performed in accordance with FCC Public Notice: APPENDIX A Guidelines for Assessing Unlicensed National Information Infrastructure (U-NII) Devices – Part 15, Subpart E, August 2002.

The transmitter output operates continuously therefore Method # 1 is used.

RESULTS

Limit

Channel	Frequency (MHz)	Fixed Limit (dBm)	B (MHz)	11 + 10 Log B Limit (dBm)	Antenna Gain (dBi)	Limit (dBm)
Low	5500	24	19.221	23.84	4.20	23.84
Mid	5600	24	23.467	24.70	4.20	24.00
High	5700	24	27.564	25.40	4.20	24.00

Results

Channel	Frequency (MHz)	Power (dBm)	Limit (dBm)	Margin (dB)
Low	5500	17.26	23.84	-6.58
Mid	5600	17.69	24.00	-6.31
High	5700	18.15	24.00	-5.85

OUTPUT POWER

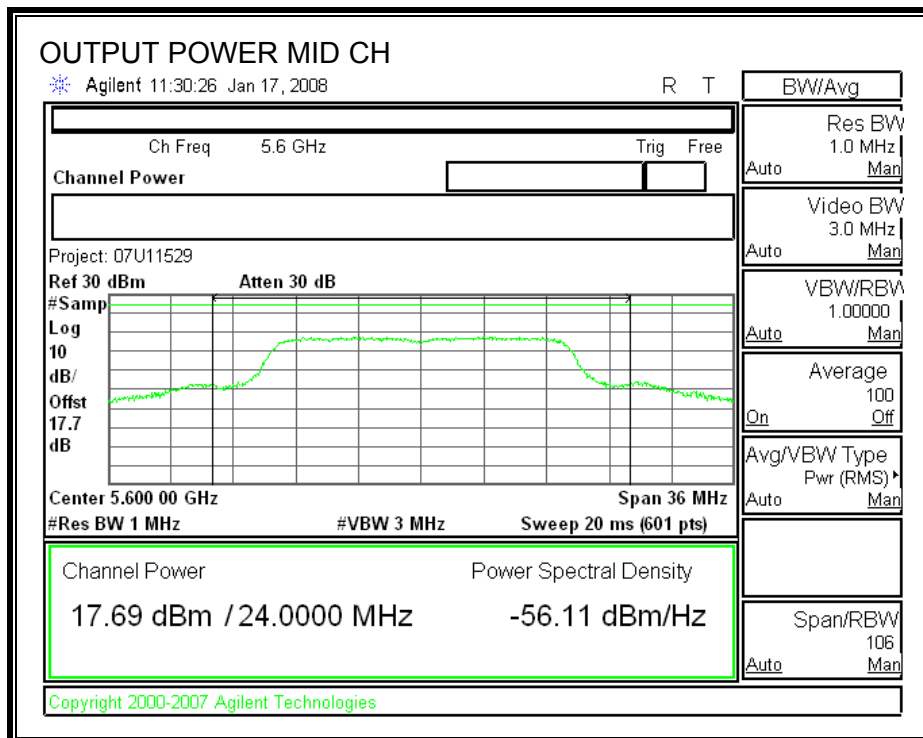
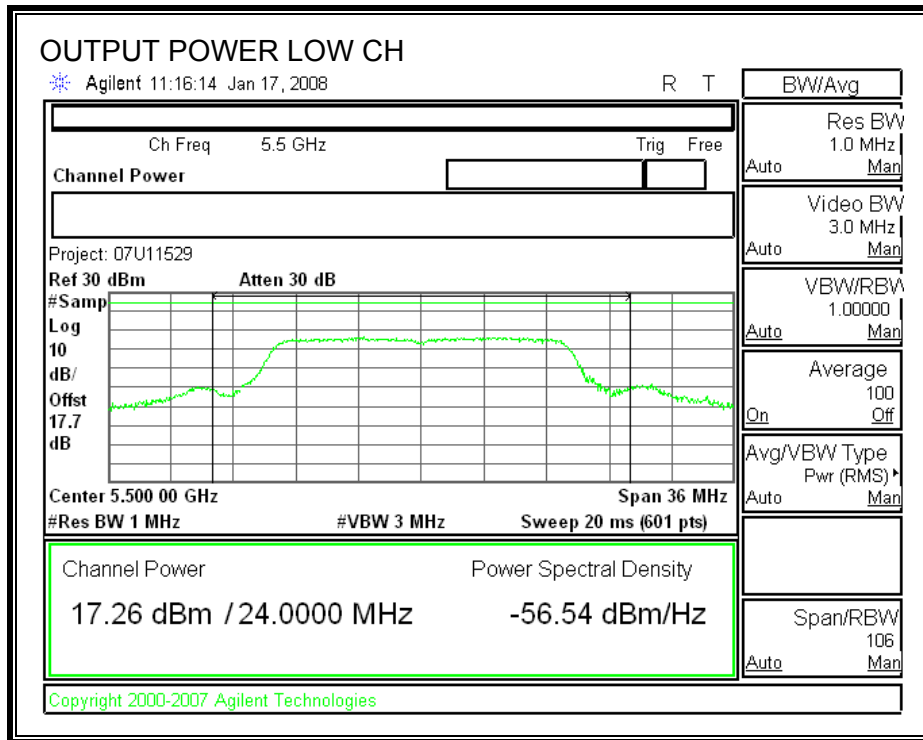

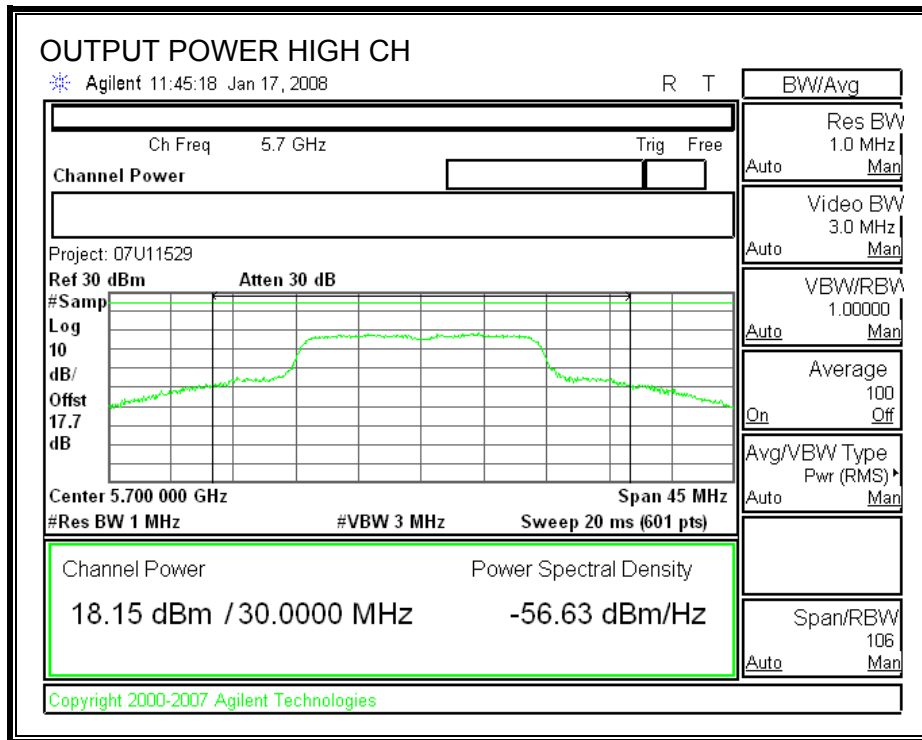

9.1.3. PEAK POWER SPECTRAL DENSITY

LIMITS

FCC §15.407 (a) (2)

IC RSS-210 A9.2 (2)

For the 5.47-5.725 GHz band, the peak power spectral density shall not exceed 11 dBm in any 1 MHz band. If transmitting antennas of directional gain greater than 6 dBi are used, both the peak transmit power and the peak power spectral density shall be reduced by the amount in dB that the directional gain of the antenna exceeds 6 dBi.

The maximum antenna gain is less than or equal to 6 dBi, therefore the limit is 11 dBm.

TEST PROCEDURE

The test is performed in accordance with FCC Public Notice: APPENDIX A Guidelines for Assessing Unlicensed National Information Infrastructure (U-NII) Devices – Part 15, Subpart E, August 2002. PPSD method #2 was used.

RESULTS

Channel	Frequency (MHz)	PPSD (dBm)	Limit (dBm)	Margin (dB)
Low	5500	6.688	11	-4.31
Middle	5600	7.410	11	-3.59
High	5700	8.162	11	-2.84

POWER SPECTRAL DENSITY

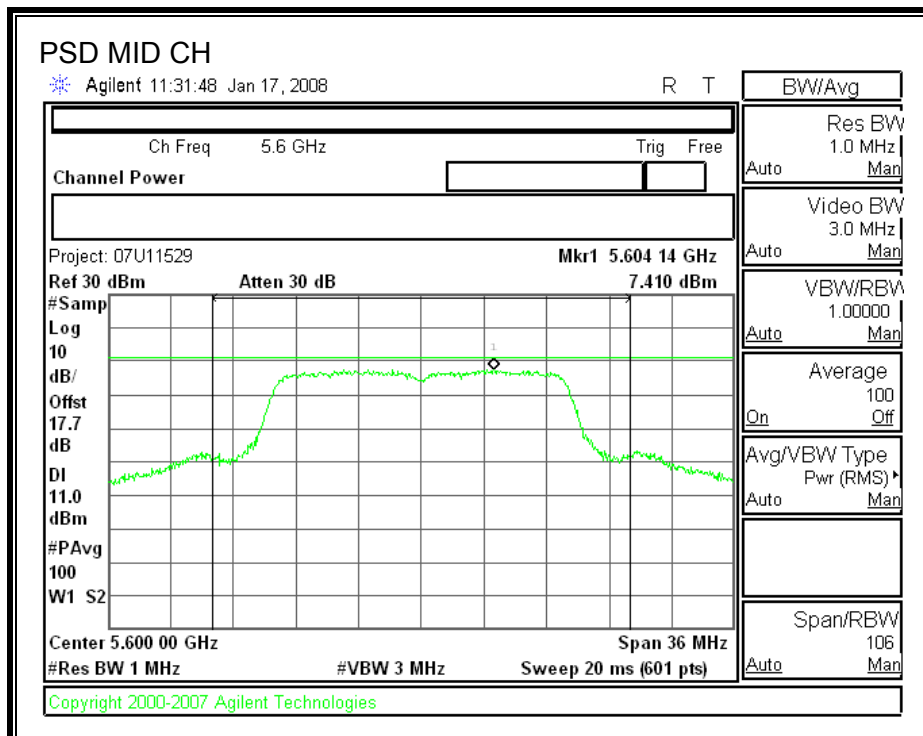
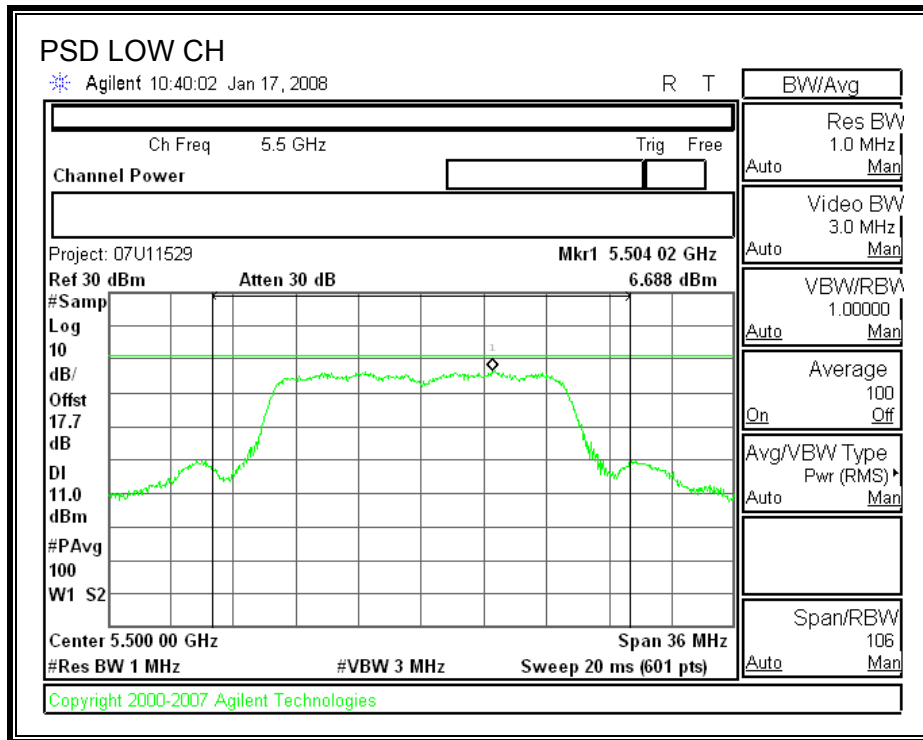

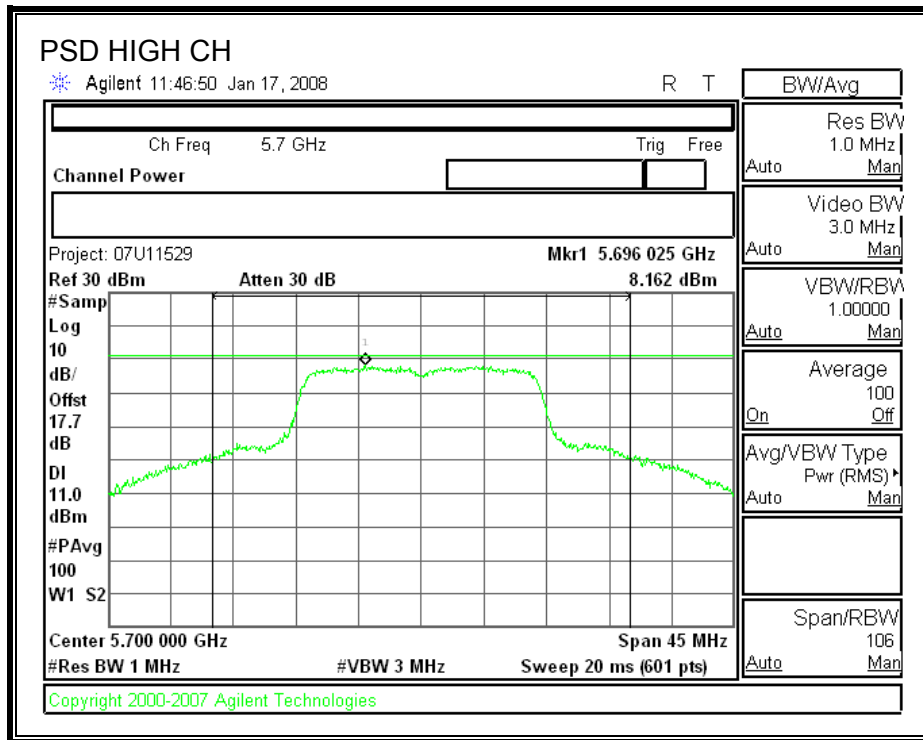

9.1.4. PEAK EXCURSION

LIMITS

FCC §15.407 (a) (6)

The ratio of the peak excursion of the modulation envelope (measured using a peak hold function) to the peak transmit power (measured as specified above) shall not exceed 13 dB across any 1 MHz bandwidth or the emission bandwidth whichever is less.

TEST PROCEDURE

The test is performed in accordance with FCC Public Notice: APPENDIX A Guidelines for Assessing Unlicensed National Information Infrastructure (U-NII) Devices – Part 15, Subpart E, August 2002.

Since Method # 1 was used for peak power measurements, Method # 1 settings are used for the second PPSD trace.

RESULTS

Channel	Frequency (MHz)	Peak Excursion (dB)	Limit (dB)	Margin (dB)
Low	5500	10.22	13	-2.78
Middle	5600	9.90	13	-3.10
High	5700	9.00	13	-4.00

PEAK EXCURSION

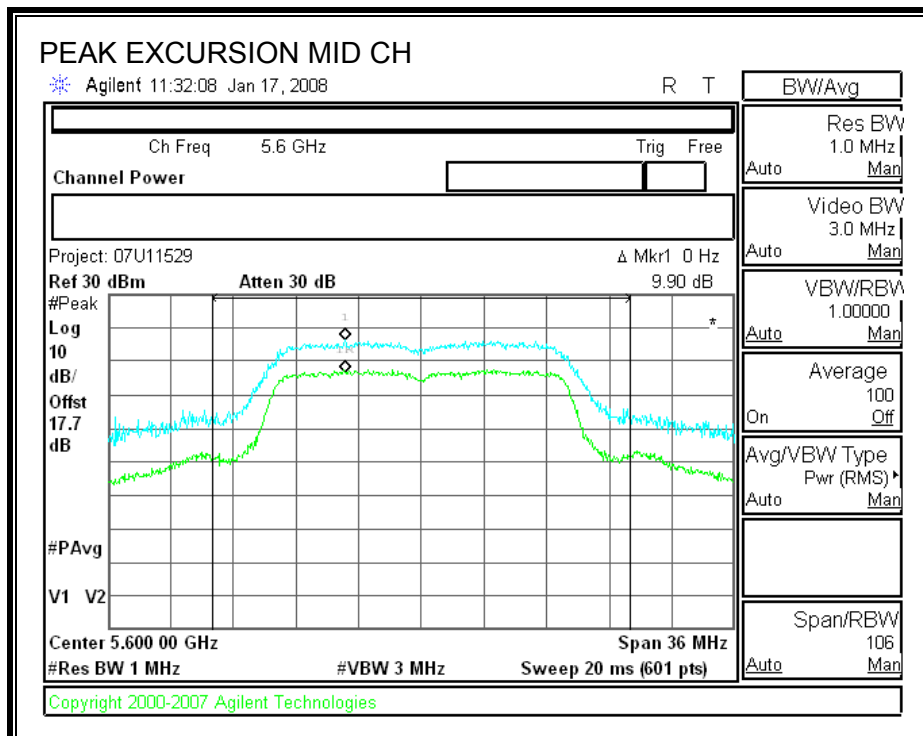
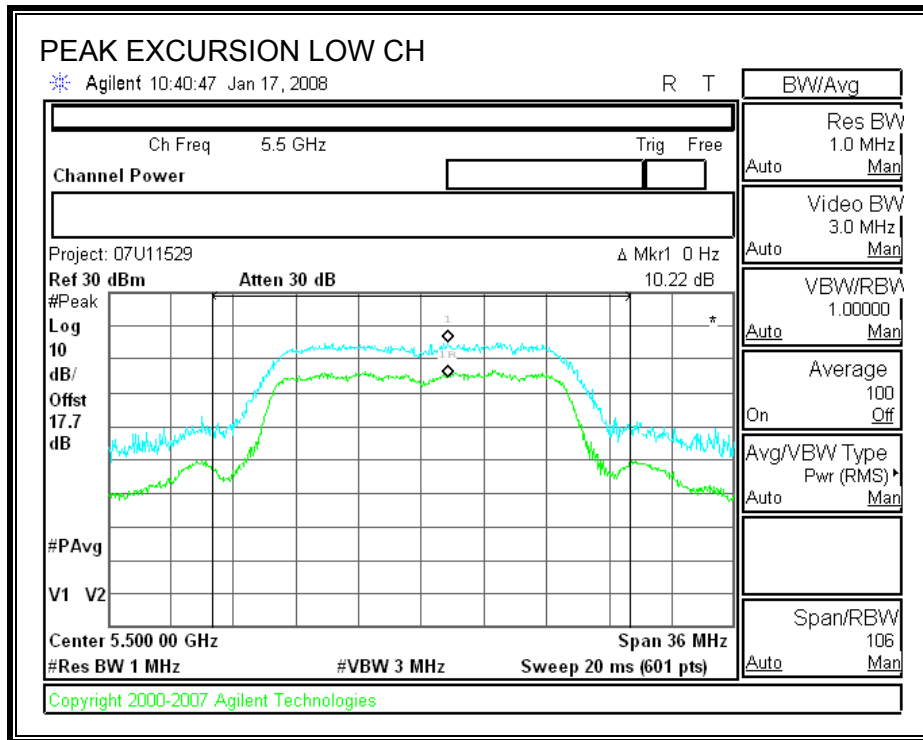

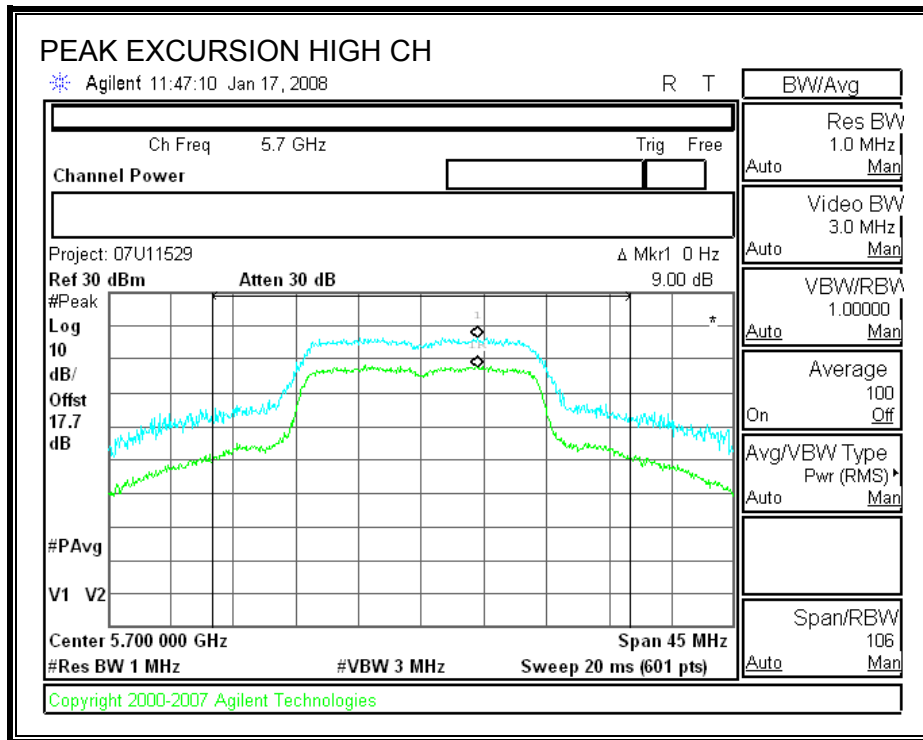

9.1.5. CONDUCTED SPURIOUS EMISSIONS

LIMITS

FCC §15.407 (b) (3)

IC RSS-210 A9.3 (3)

For transmitters operating in the 5.47-5.725 GHz band: all emissions outside of the 5.47-5.725 GHz band shall not exceed an EIRP of -27 dBm / MHz.

Limit line = -27 - EUT Antenna Gain

TEST PROCEDURE

Conducted RF measurements of the transmitter output are made to confirm that the EUT antenna port conducted emissions meet the specified limit and to identify any spurious signals that require further investigation or measurements on the radiated emissions site.

The transmitter output is connected to the spectrum analyzer. The resolution bandwidth is set to 1 MHz. The video bandwidth is set to 1 MHz. Peak detection measurements are compared to the average EIRP limit, adjusted for the maximum antenna gain. If necessary, additional average detection measurements are made.

Measurements are made over the 30 MHz to 40 GHz range with the transmitter set to the lowest, middle, and highest channels.

RESULTS

SPURIOUS EMISSIONS

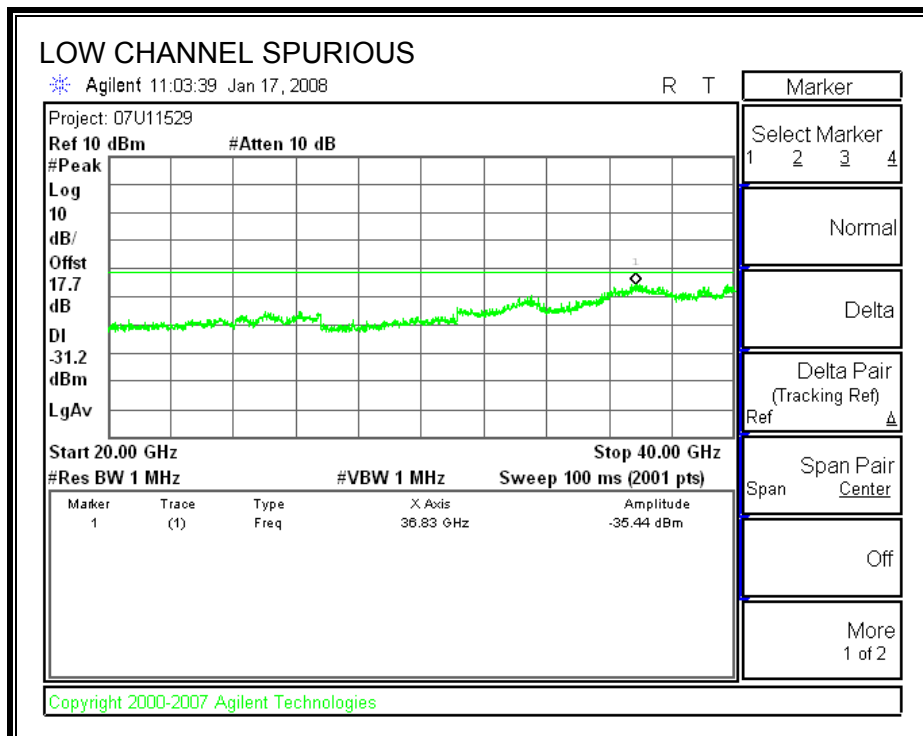
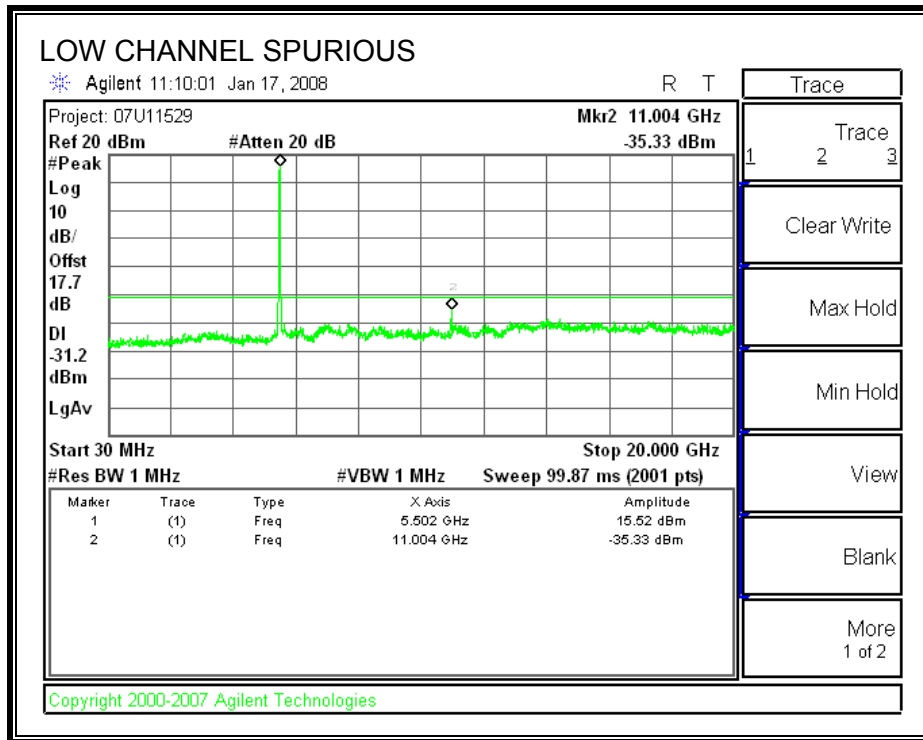

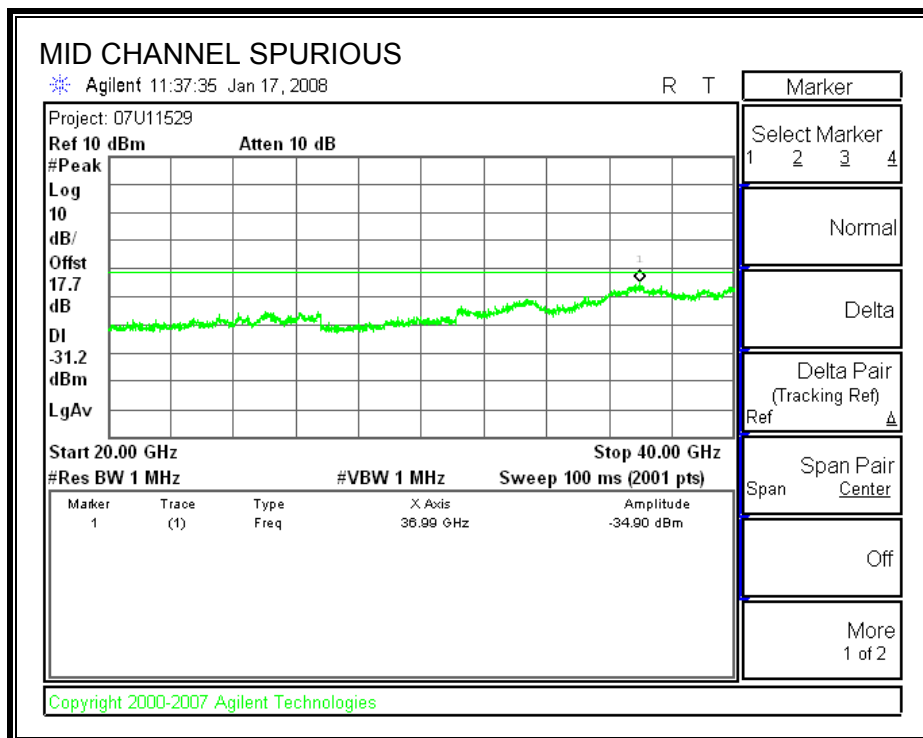
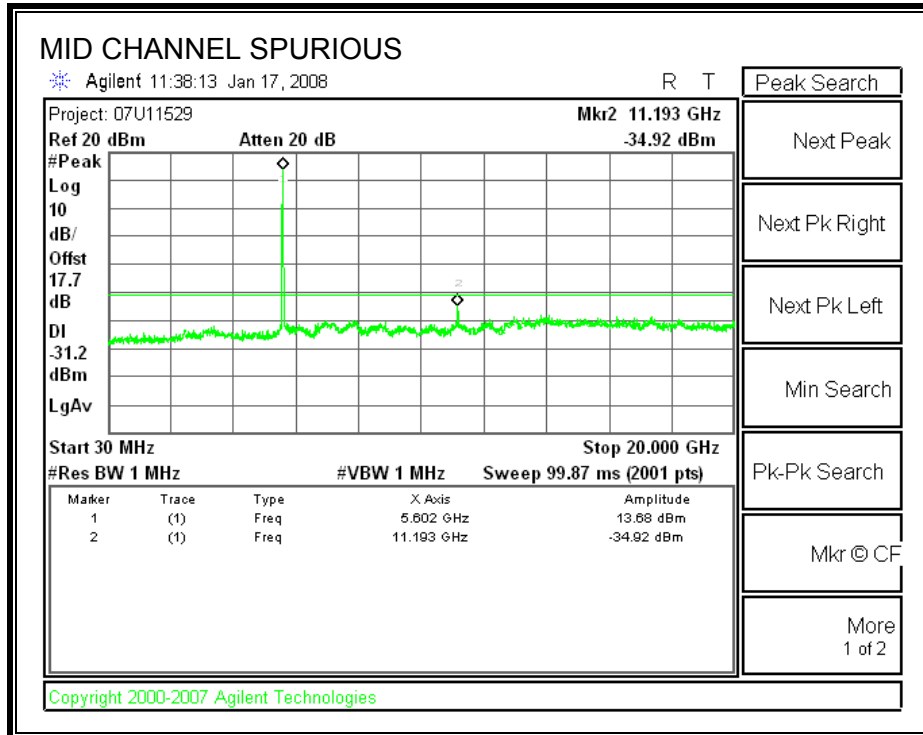

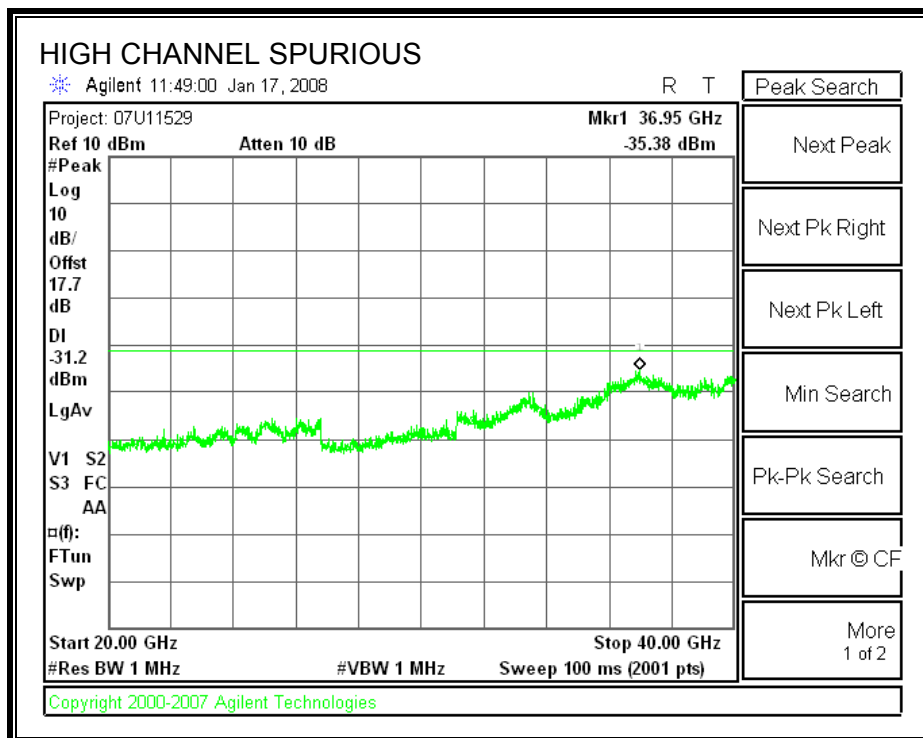
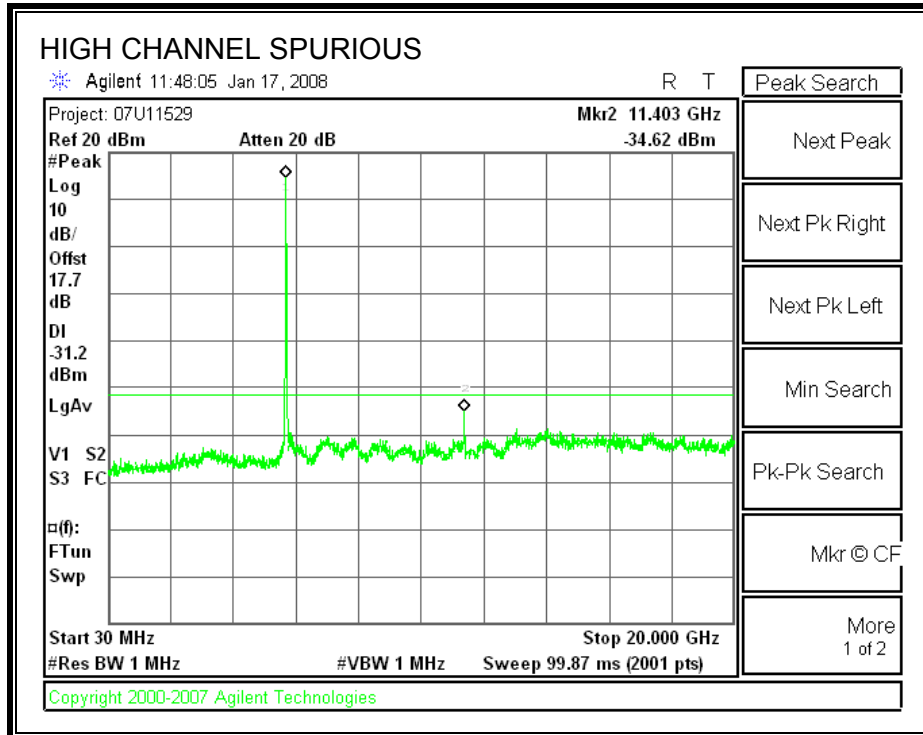

9.2. 802.11n HT20 MODE

9.2.1. 26 dB and 99% BANDWIDTH

LIMITS

None; for reporting purposes only.

TEST PROCEDURE

The transmitter outputs are connected to the spectrum analyzer via a combiner. The RBW is set to 1% to 3% of the measured bandwidth. The VBW is set to 3 times the RBW. The sweep time is coupled. The spectrum analyzer internal bandwidth function is utilized.

RESULTS

Channel	Frequency (MHz)	26 dB Bandwidth (MHz)	99% Bandwidth (MHz)
Low	5500	22.130	16.490
Middle	5600	27.550	17.760
High	5700	29.503	17.860

26 dB and 99% BANDWIDTH

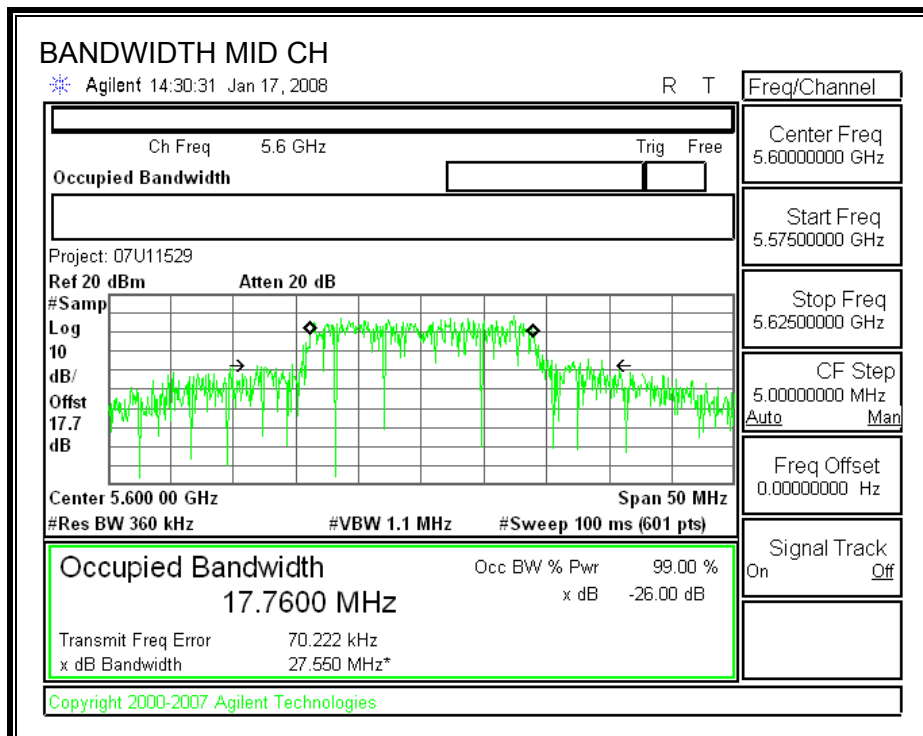
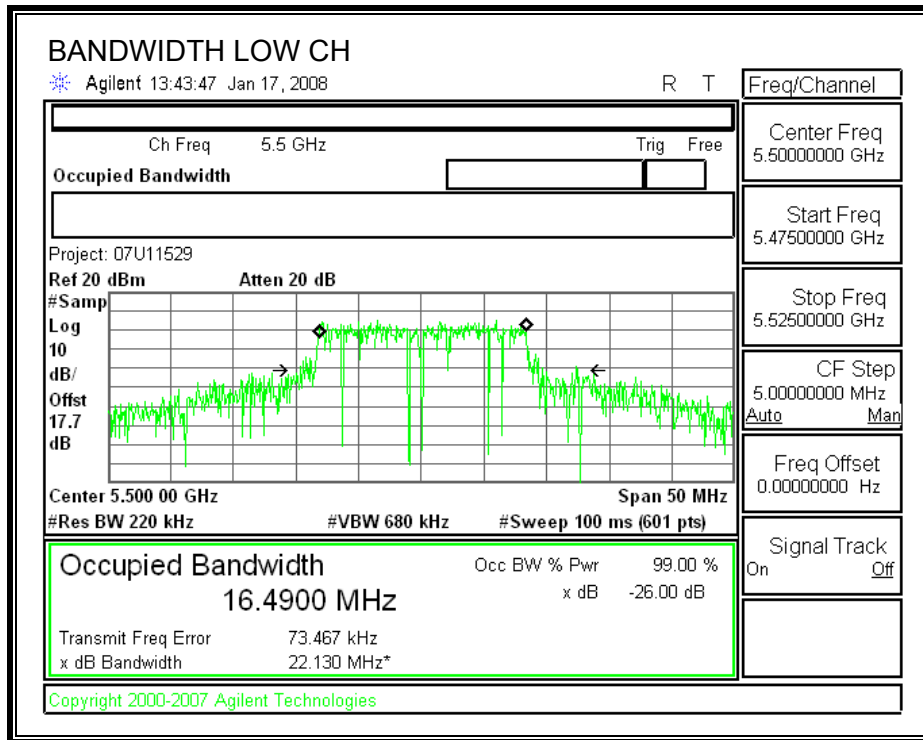

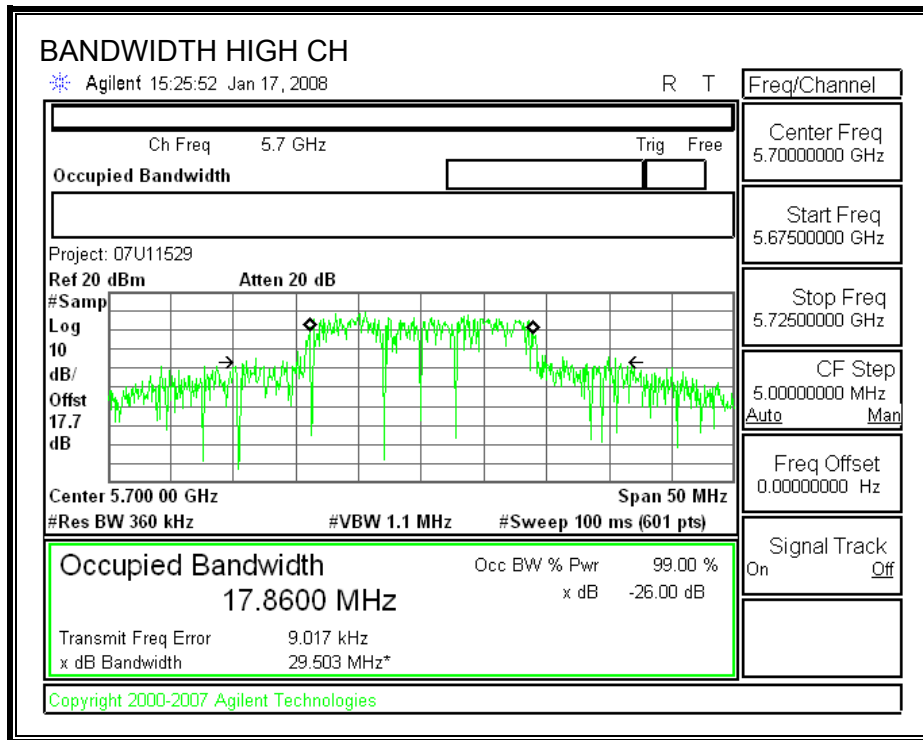

9.2.2. OUTPUT POWER

LIMITS

FCC §15.407 (a) (2)

IC RSS-210 A9.2 (2)

For the 5.47-5.725 GHz band, the maximum conducted output power over the frequency band of operation shall not exceed the lesser of 250 mW or $11 \text{ dBm} + 10 \log B$, where B is the 26-dB emission bandwidth in MHz. If transmitting antennas of directional gain greater than 6 dBi are used, both the peak transmit power and the peak power spectral density shall be reduced by the amount in dB that the directional gain of the antenna exceeds 6 dBi.

TEST PROCEDURE

The test is performed in accordance with FCC Public Notice: APPENDIX A Guidelines for Assessing Unlicensed National Information Infrastructure (U-NII) Devices – Part 15, Subpart E, August 2002.

The transmitter output operates continuously therefore Method # 1 is used.

RESULTS

6dBi Antenna Gain

Limit

Channel	Frequency (MHz)	Fixed Limit (dBm)	B (MHz)	11 + 10 Log B Limit (dBm)	Antenna Gain (dBi)	Limit (dBm)
Low	5500	24	22.130	24.45	6.00	24.00
Mid	5600	24	27.550	25.40	6.00	24.00
High	5700	24	29.503	25.70	6.00	24.00

Individual Chain Results

Channel	Frequency (MHz)	Chain 0 Power (dBm)	1 Power (dBm)	Total Power (dBm)	Limit (dBm)	Margin (dB)
Low	5500	16.60	16.61	19.62	24.00	-4.38
Mid	5600	17.29	17.13	20.22	24.00	-3.78
High	5700	17.30	17.14	20.23	24.00	-3.77

7.21dBi Antenna Gain

Limit

Channel	Frequency (MHz)	Fixed Limit (dBm)	B (MHz)	11 + 10 Log B Limit (dBm)	Antenna Gain (dBi)	Limit (dBm)
Low	5500	24	22.130	24.45	7.21	22.79
Mid	5600	24	27.550	25.40	7.21	22.79
High	5700	24	29.503	25.70	7.21	22.79

Individual Chain Results

Channel	Frequency (MHz)	Chain 1 Power (dBm)	Chain 2 Power (dBm)	Total Power (dBm)	Limit (dBm)	Margin (dB)
Low	5500	16.34	16.11	19.24	22.79	-3.55
Mid	5600	16.43	16.03	19.24	22.79	-3.55
High	5700	16.48	16.11	19.31	22.79	-3.48

CHAIN 0 OUTPUT POWER (6 dBi Antenna Gain)

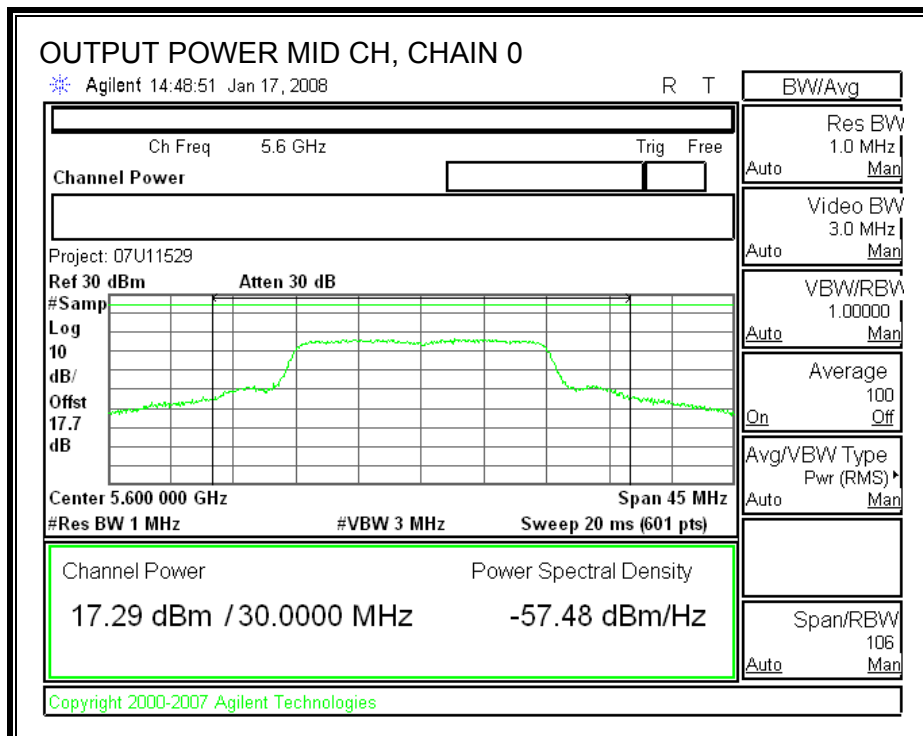
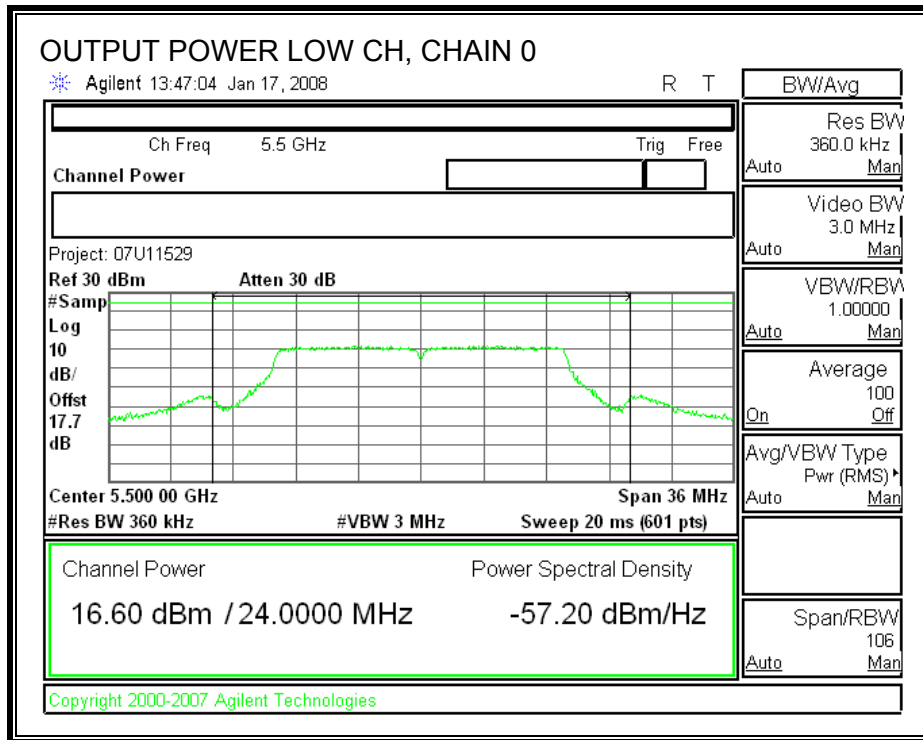

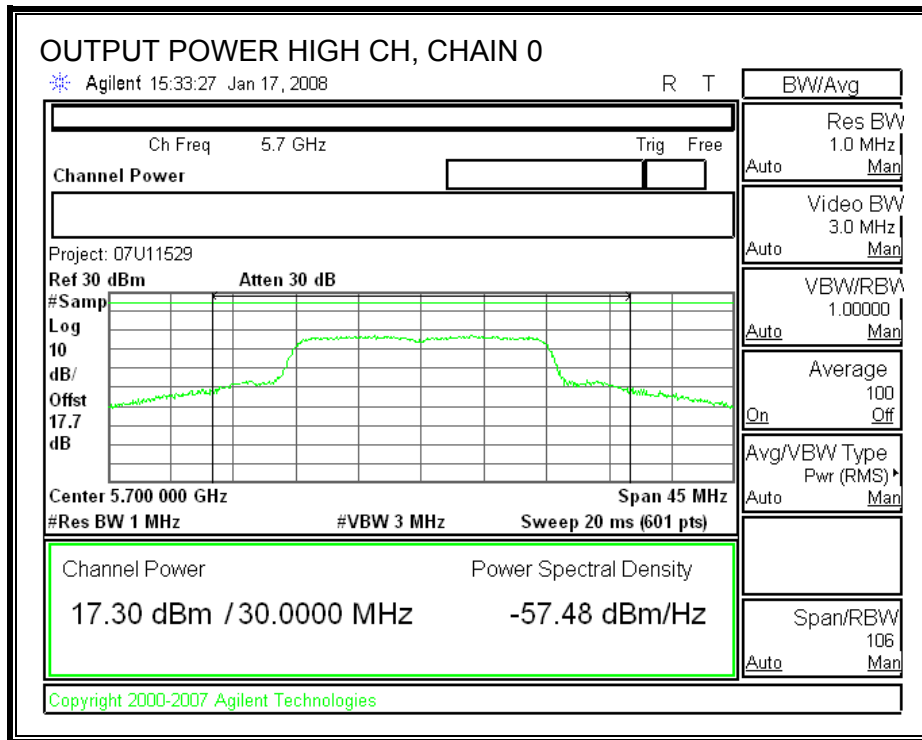

CHAIN 1 OUTPUT POWER (6 dBi Antenna Gain)

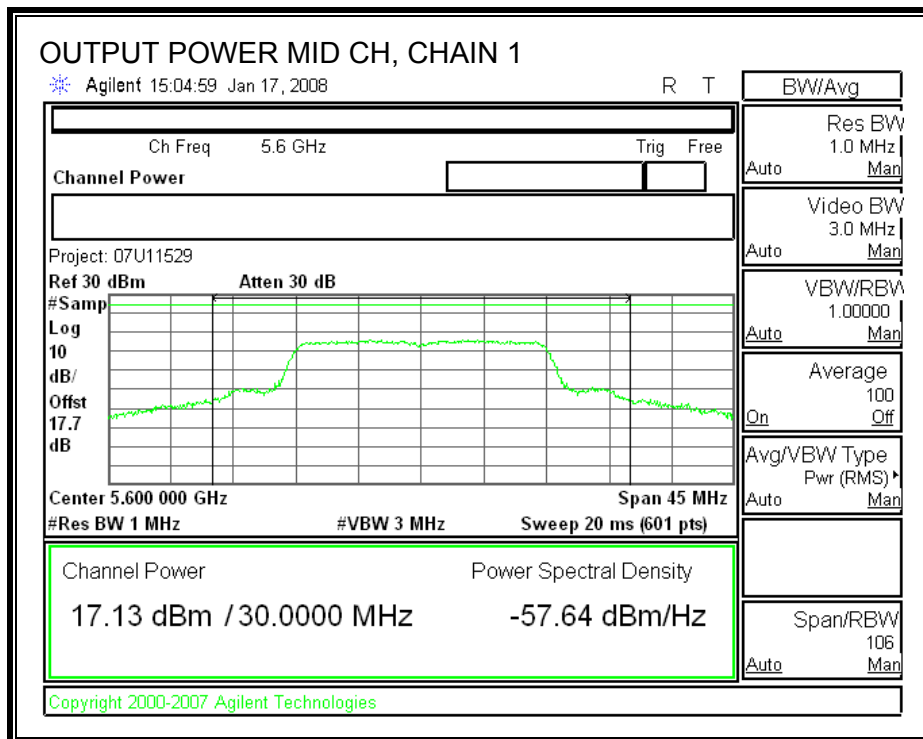
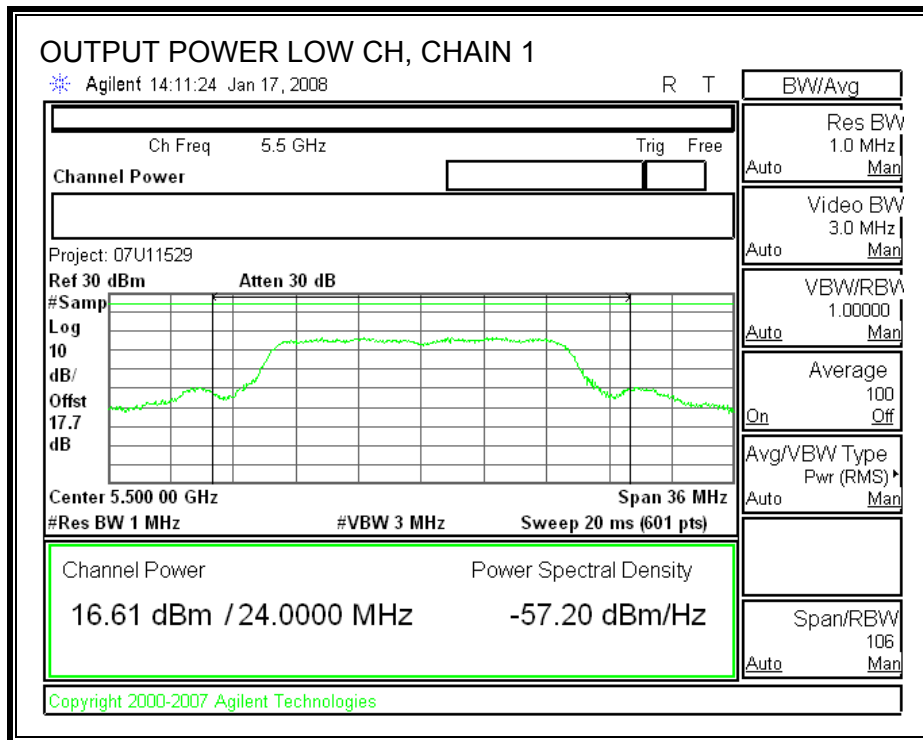

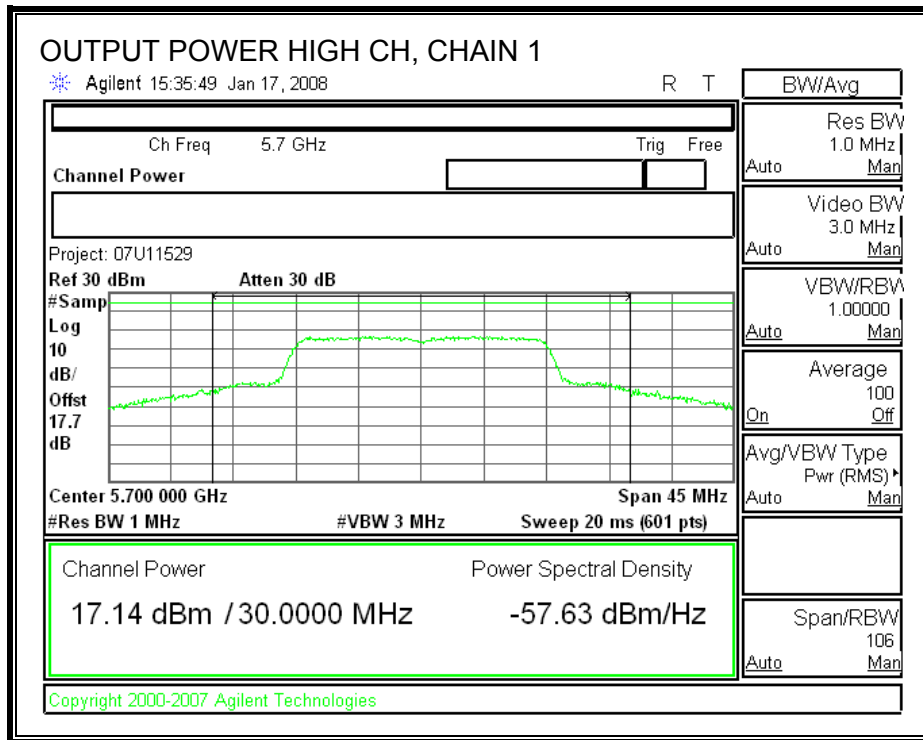

CHAIN 0 OUTPUT POWER (7.21 dBi Antenna Gain)

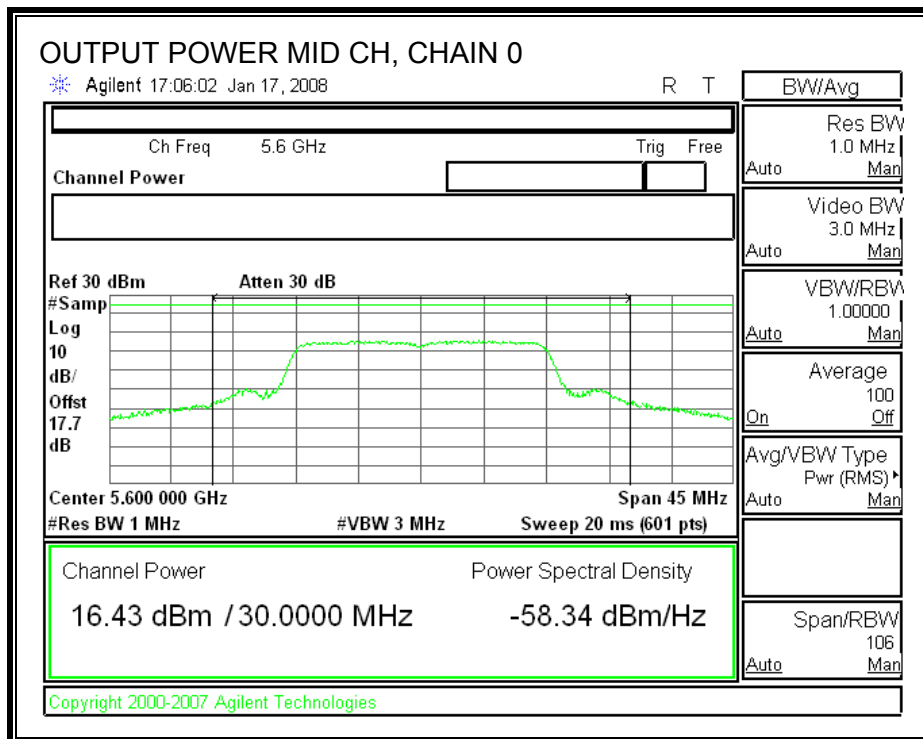
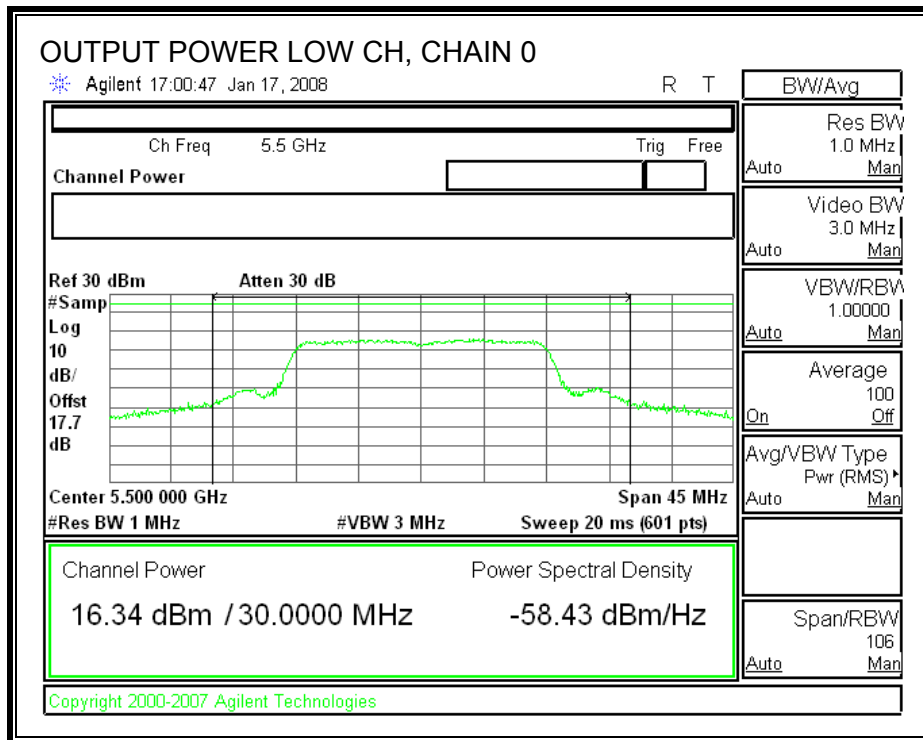

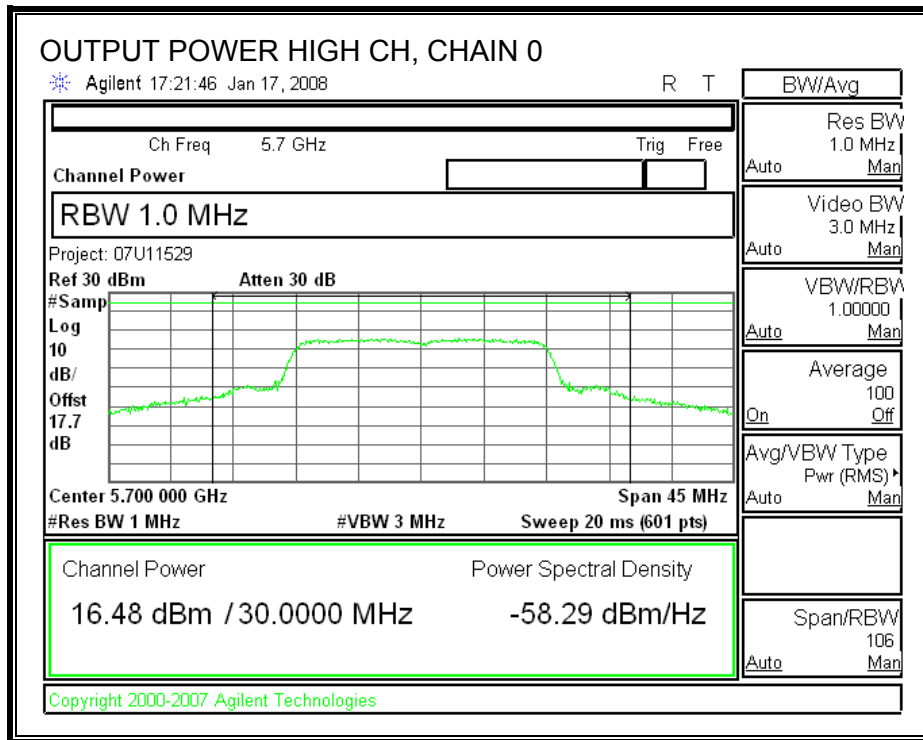

CHAIN 1 OUTPUT POWER (7.21 dBi Antenna Gain)

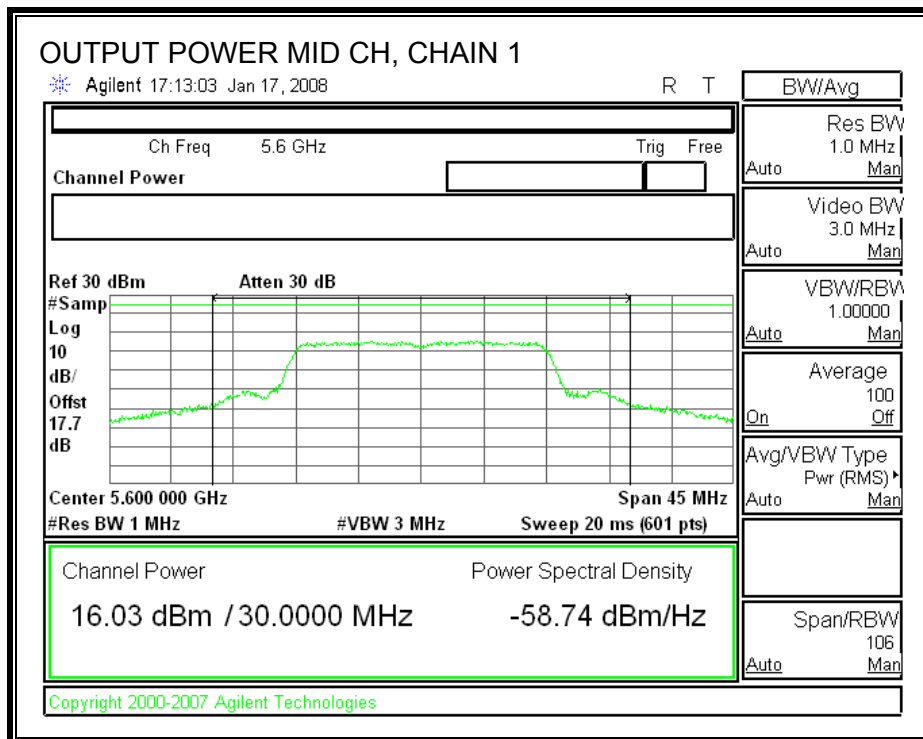
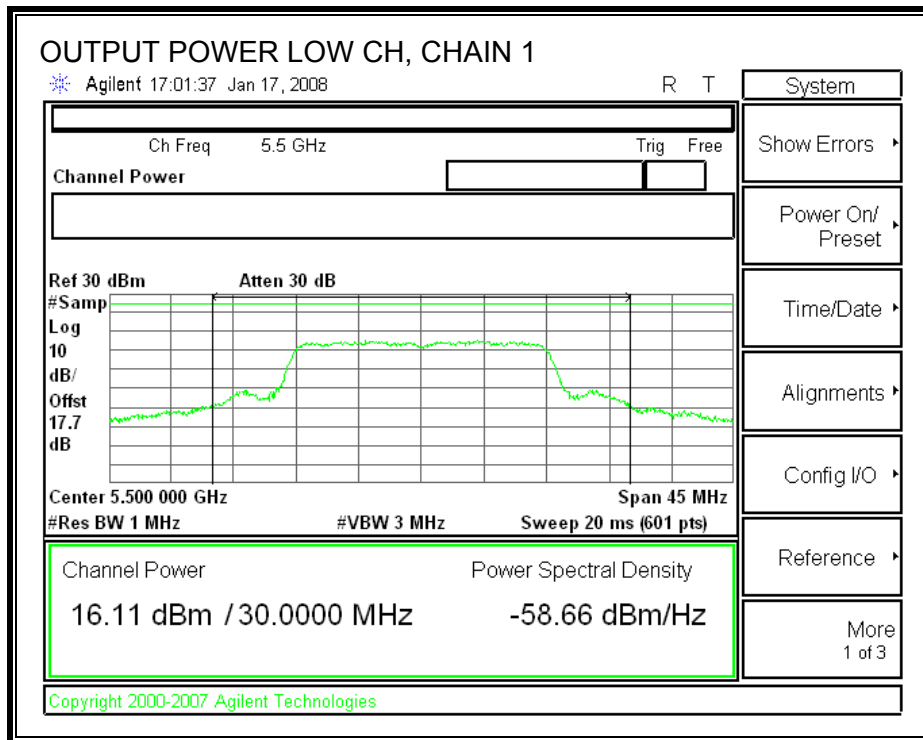

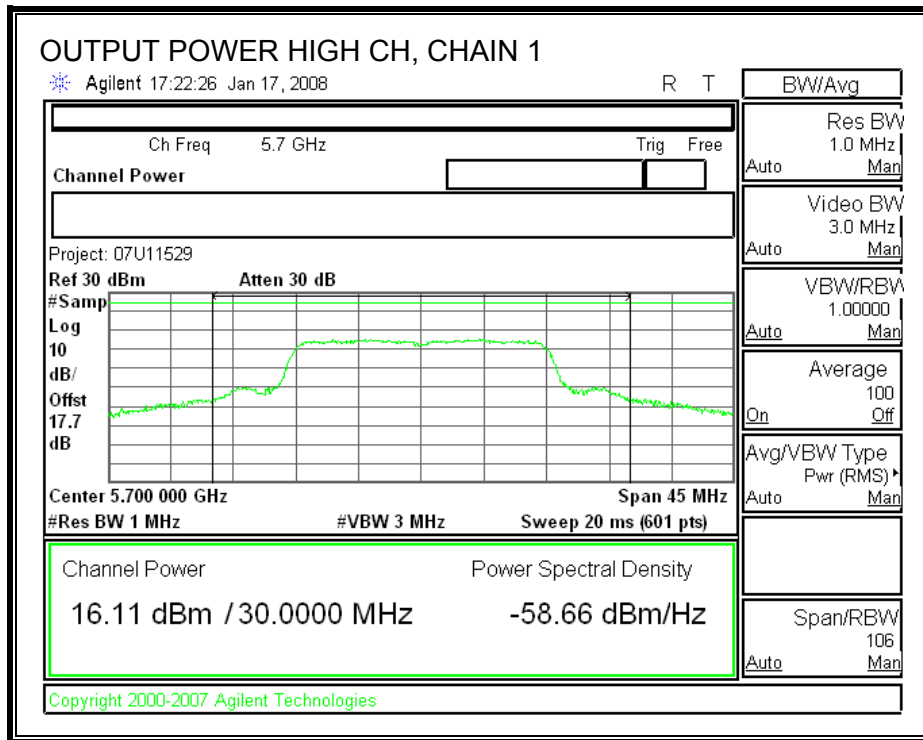

9.2.3. PEAK POWER SPECTRAL DENSITY

LIMITS

FCC §15.407 (a) (2)

IC RSS-210 A9.2 (2)

For the 5.47-5.725 GHz band, the peak power spectral density shall not exceed 11 dBm in any 1 MHz band. If transmitting antennas of directional gain greater than 6 dBi are used, both the peak transmit power and the peak power spectral density shall be reduced by the amount in dB that the directional gain of the antenna exceeds 6 dBi.

The maximum antenna gain is less than or equal to 6 dBi, therefore the limit is 11 dBm.

The maximum antenna gain is 7.21 dBi, therefore the limit is 9.79 dBm.

TEST PROCEDURE

The test is performed in accordance with FCC Public Notice: APPENDIX A Guidelines for Assessing Unlicensed National Information Infrastructure (U-NII) Devices – Part 15, Subpart E, August 2002. PPSD method #2 was used.

RESULTS

6dBi Antenna Gain

Channel	Frequency (MHz)	PPSD With Combiner (dBm)	Limit (dBm)	Margin (dB)
Low	5500	9.997	11	-1.00
Middle	5600	10.588	11	-0.41
High	5700	10.584	11	-0.42

7.21dBi Antenna Gain

Channel	Frequency (MHz)	PPSD With Combiner (dBm)	Limit (dBm)	Margin (dB)
Low	5500	9.554	9.79	-0.24
Middle	5600	9.521	9.79	-0.27
High	5700	9.539	9.79	-0.25

POWER SPECTRAL DENSITY WITH COMBINER (6 dBi Antenna Gain)

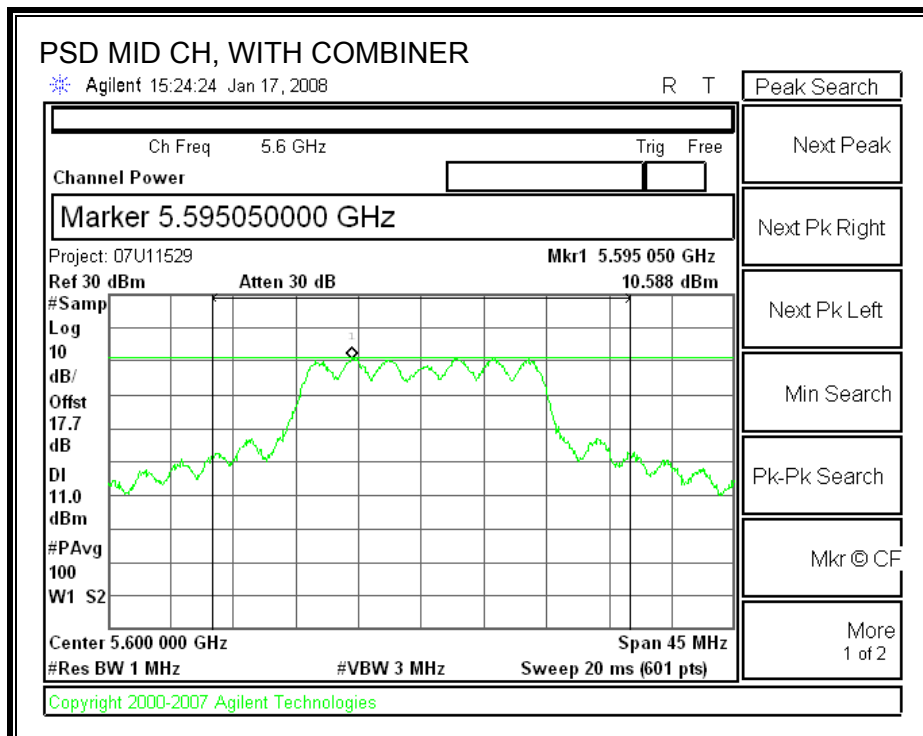
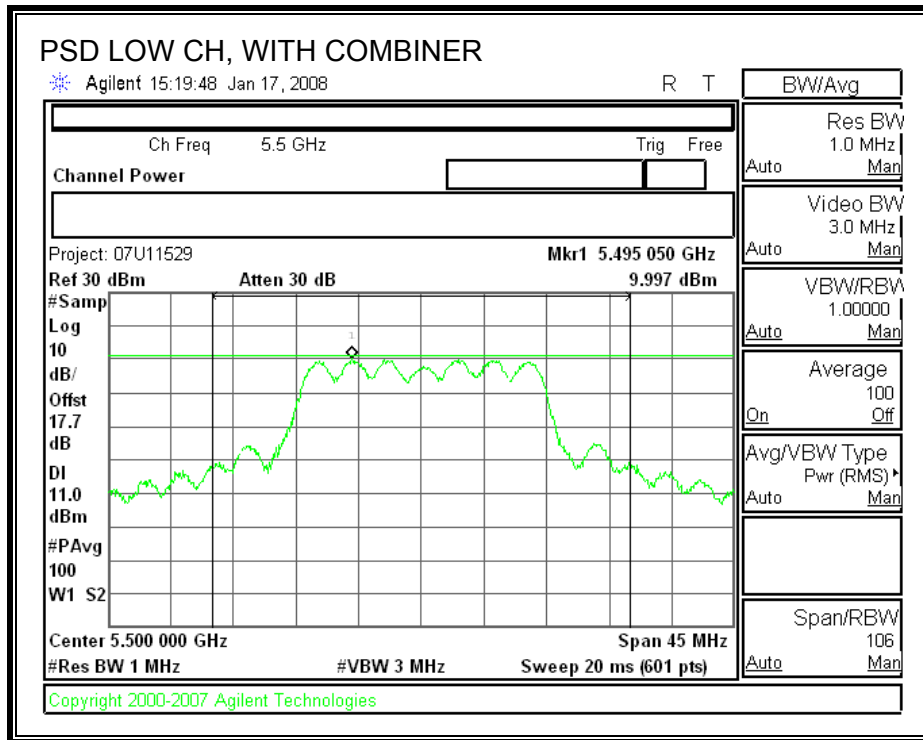

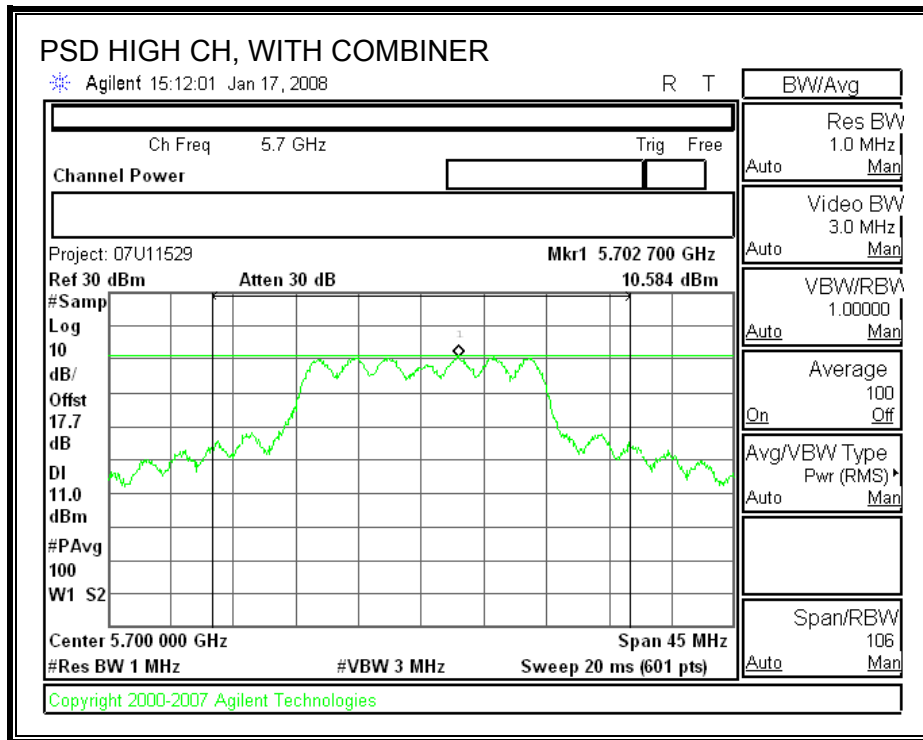

POWER SPECTRAL DENSITY WITH COMBINER (7.21 dBi Antenna Gain)

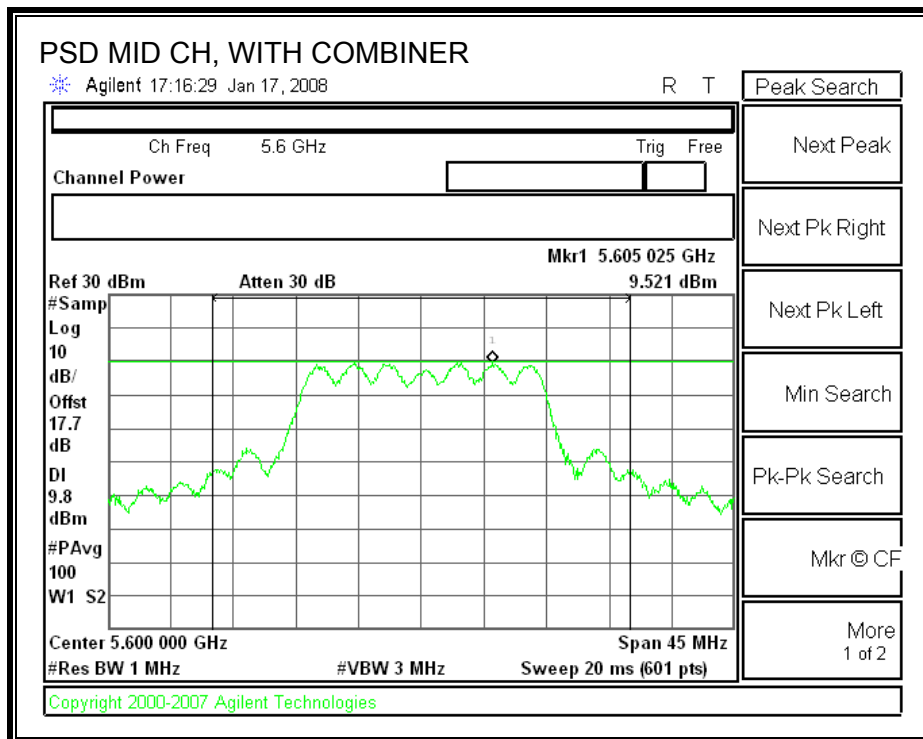
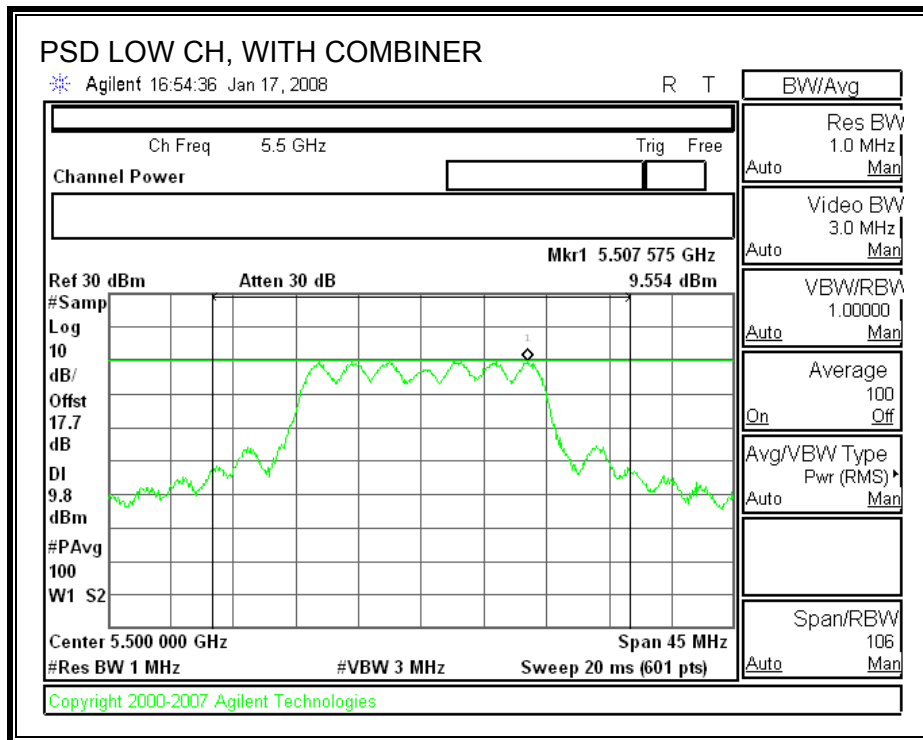

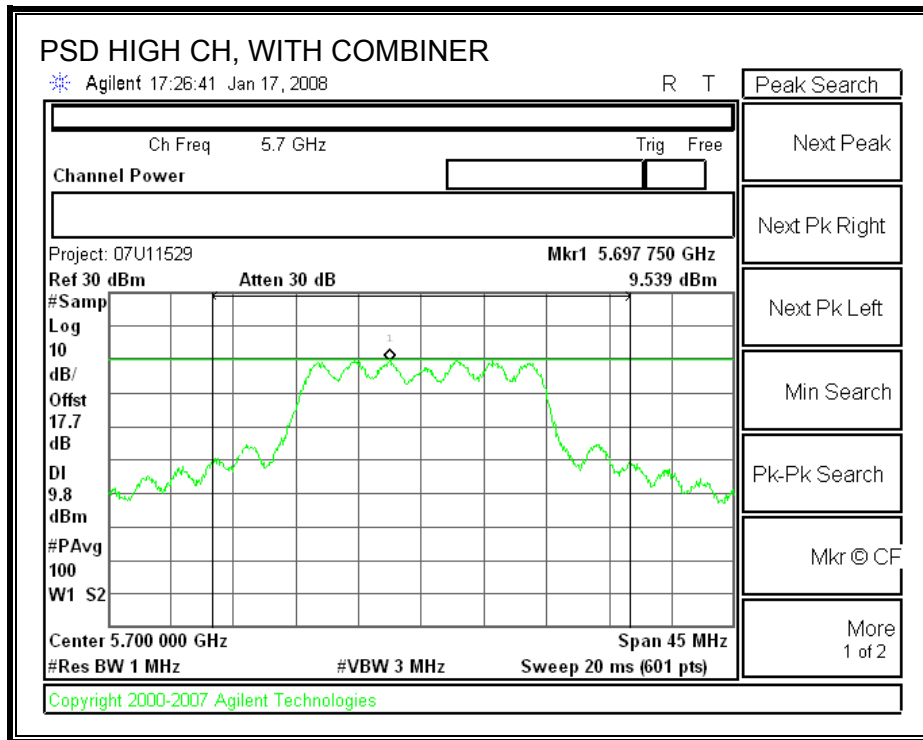

9.2.4. PEAK EXCURSION

LIMITS

FCC §15.407 (a) (6)

The ratio of the peak excursion of the modulation envelope (measured using a peak hold function) to the peak transmit power (measured as specified above) shall not exceed 13 dB across any 1 MHz bandwidth or the emission bandwidth whichever is less.

TEST PROCEDURE

The transmitter outputs are connected to the spectrum analyzer via a combiner.

The test is performed in accordance with FCC Public Notice: APPENDIX A Guidelines for Assessing Unlicensed National Information Infrastructure (U-NII) Devices – Part 15, Subpart E, August 2002.

Since Method # 1 was used for peak power measurements, Method # 1 settings are used for the second PPSD trace.

RESULTS

Chain 1

Channel	Frequency (MHz)	Peak Excursion (dB)	Limit (dB)	Margin (dB)
Low	5500	10.04	13	-2.96
Middle	5600	8.99	13	-4.01
High	5700	9.33	13	-3.67

Chain 2

Channel	Frequency (MHz)	Peak Excursion (dB)	Limit (dB)	Margin (dB)
Low	5500	9.21	13	-3.79
Middle	5600	10.96	13	-2.04
High	5700	10.21	13	-2.79

PEAK EXCURSION (CHAIN 0)

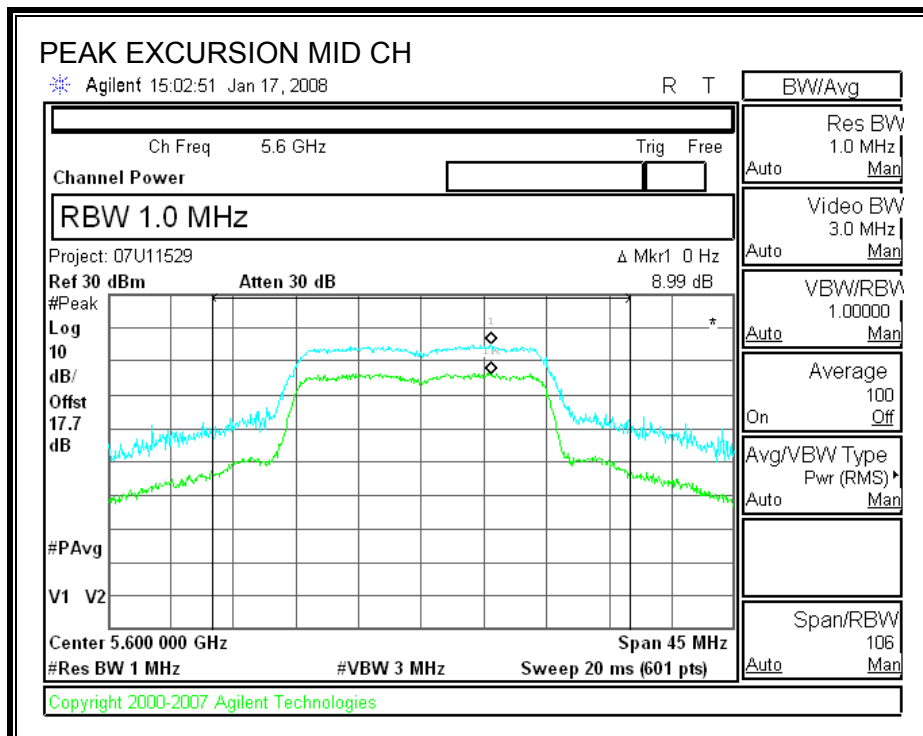
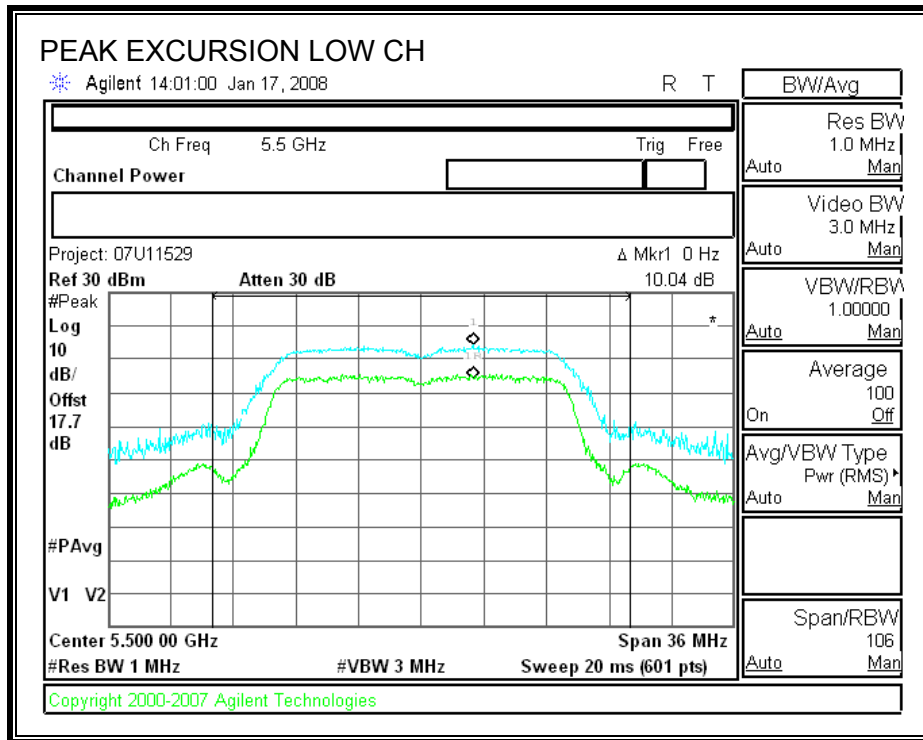

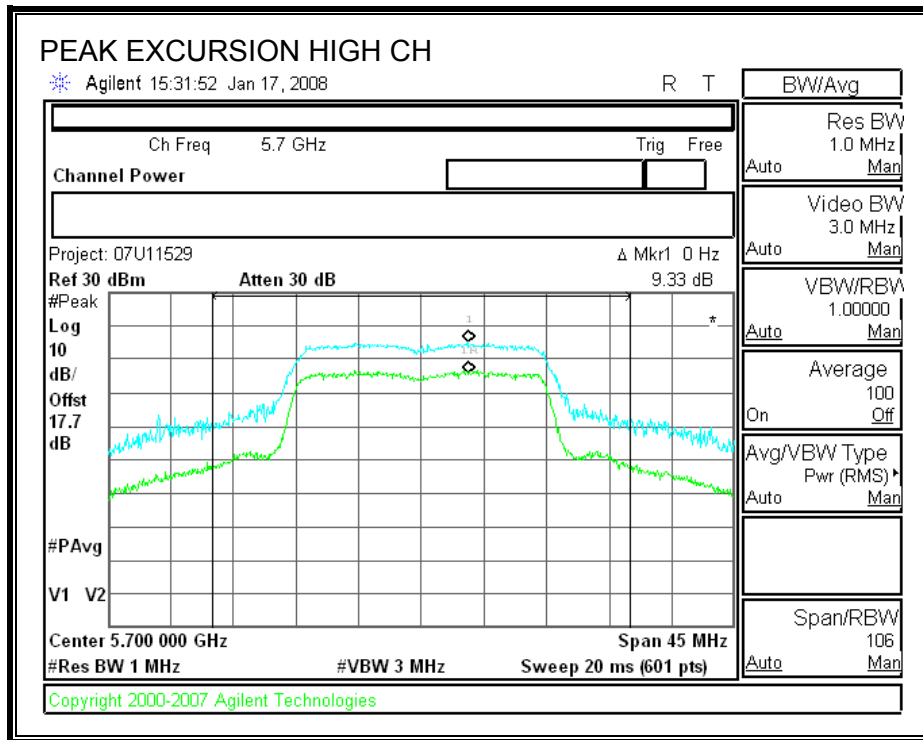

PEAK EXCURSION (CHAIN 1)

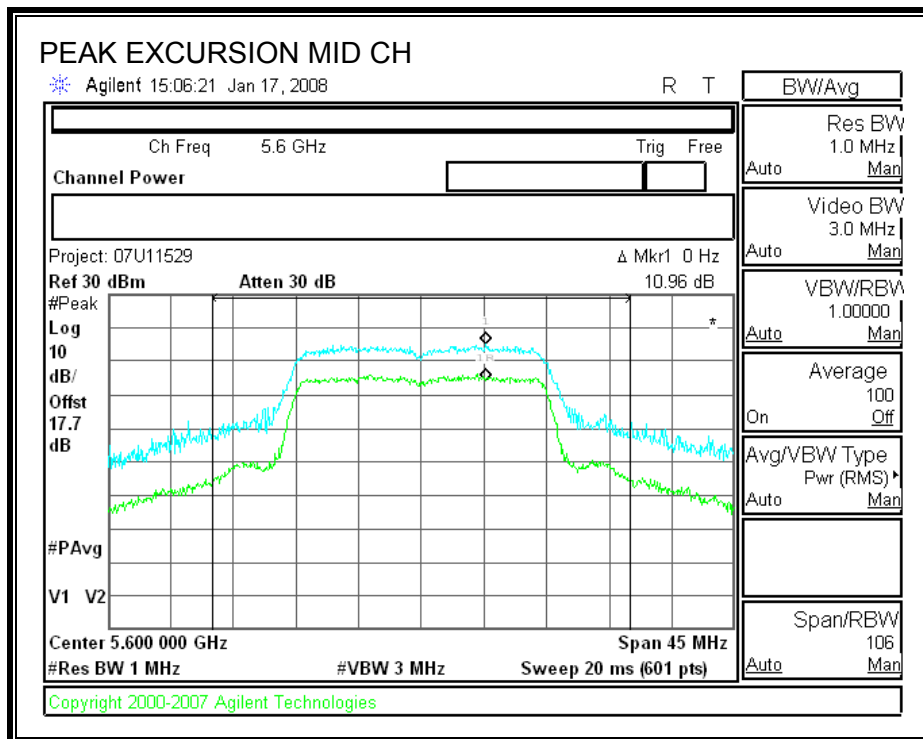
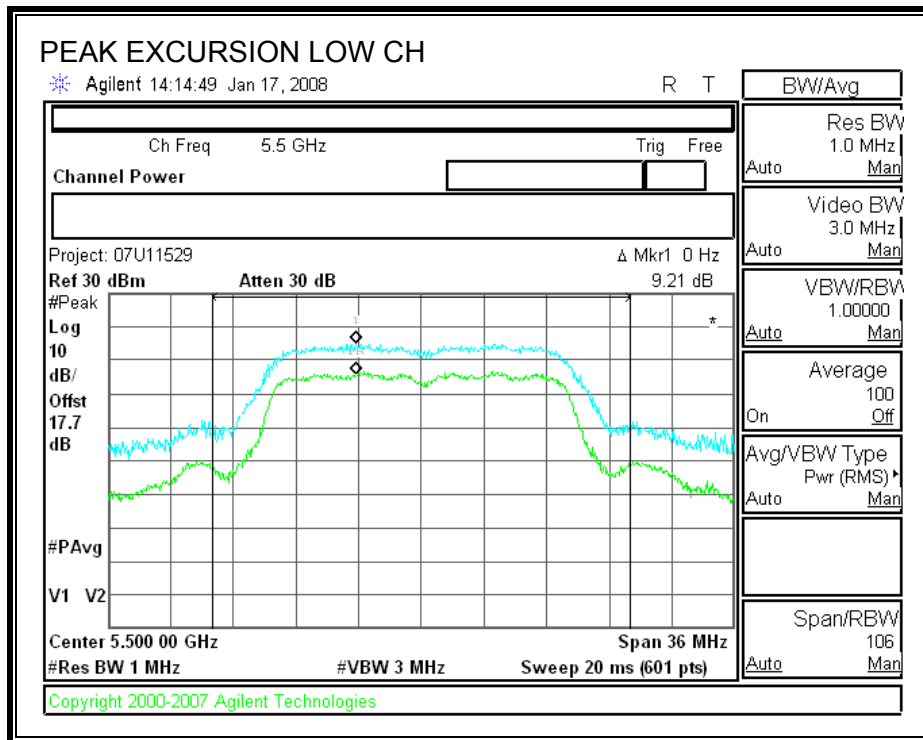

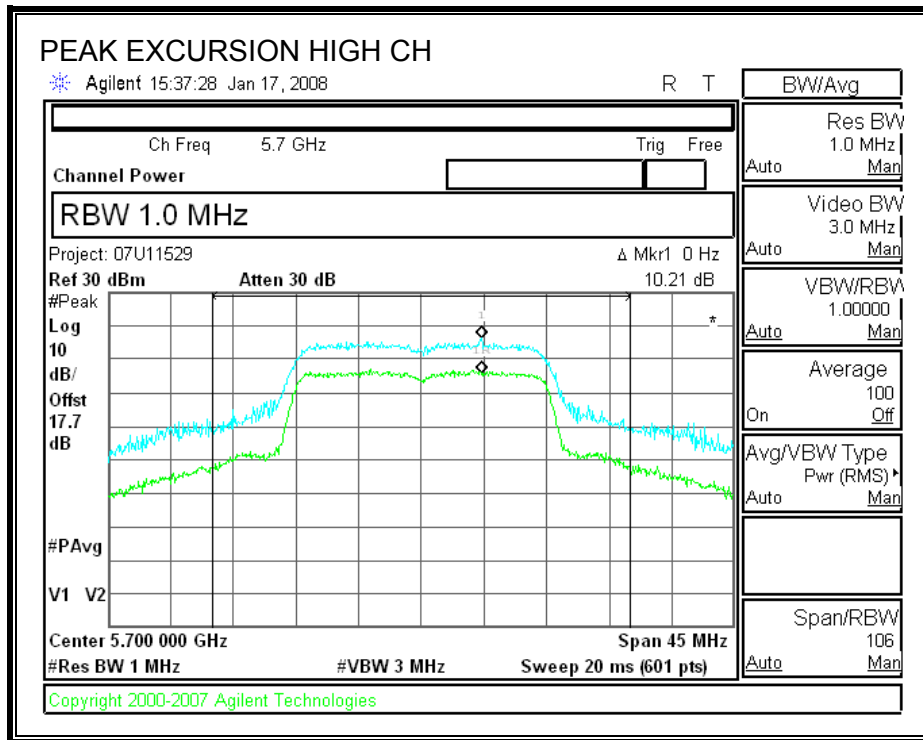

9.2.5. CONDUCTED SPURIOUS EMISSIONS

LIMITS

FCC §15.407 (b) (3)

IC RSS-210 A9.3 (3)

For transmitters operating in the 5.47-5.725 GHz band: all emissions outside of the 5.47-5.725 GHz band shall not exceed an EIRP of -27 dBm / MHz.

TEST PROCEDURE

Conducted RF measurements of the transmitter output are made to confirm that the EUT antenna port conducted emissions meet the specified limit and to identify any spurious signals that require further investigation or measurements on the radiated emissions site.

The transmitter output is connected to the spectrum analyzer. The resolution bandwidth is set to 1 MHz. The video bandwidth is set to 1 MHz. Peak detection measurements are compared to the average EIRP limit, adjusted for the maximum antenna gain. If necessary, additional average detection measurements are made.

Measurements are made over the 30 MHz to 40 GHz range with the transmitter set to the lowest, middle, and highest channels.

RESULTS

SPURIOUS EMISSIONS WITH COMBINER

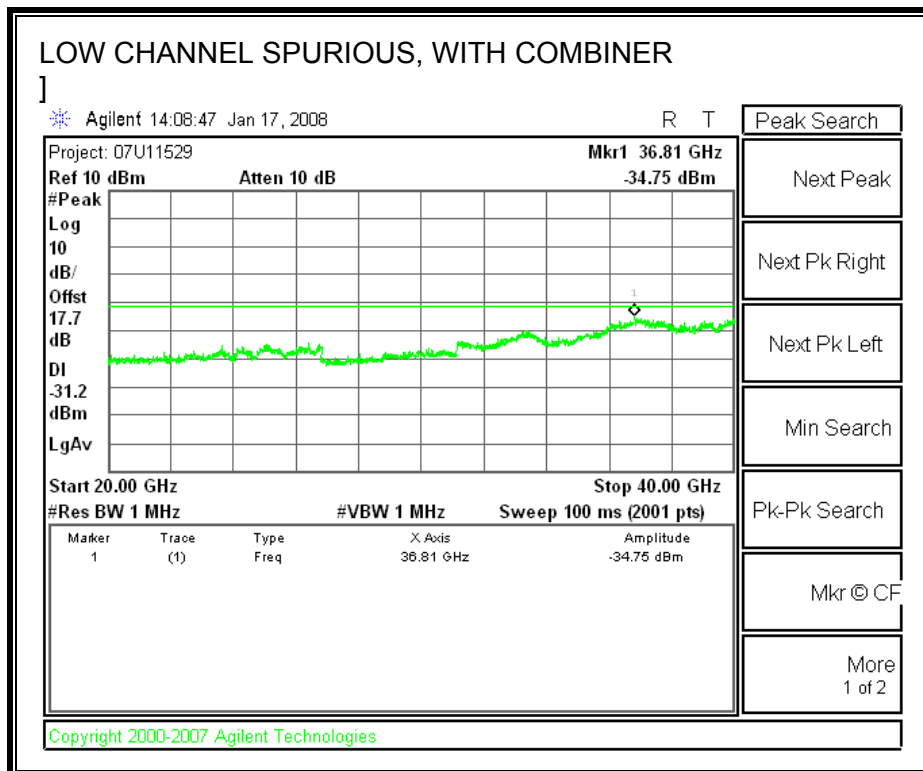
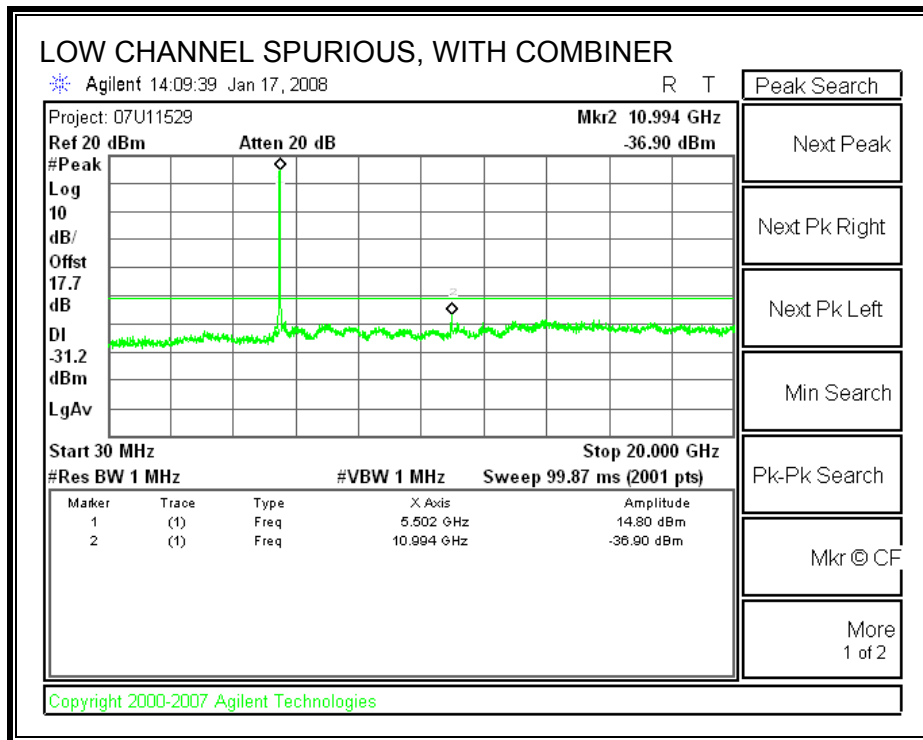

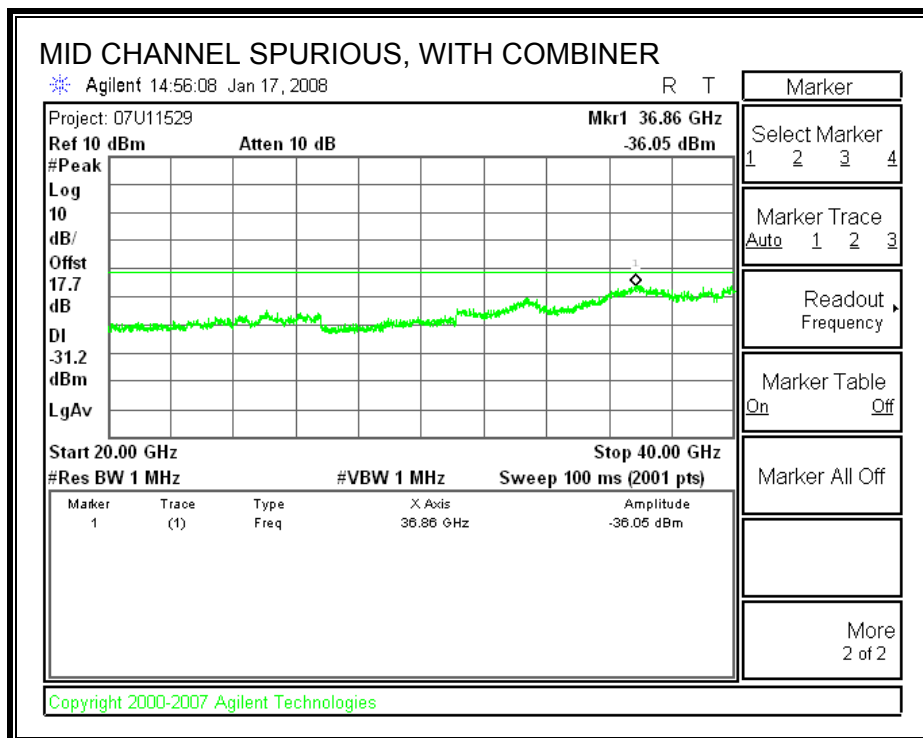
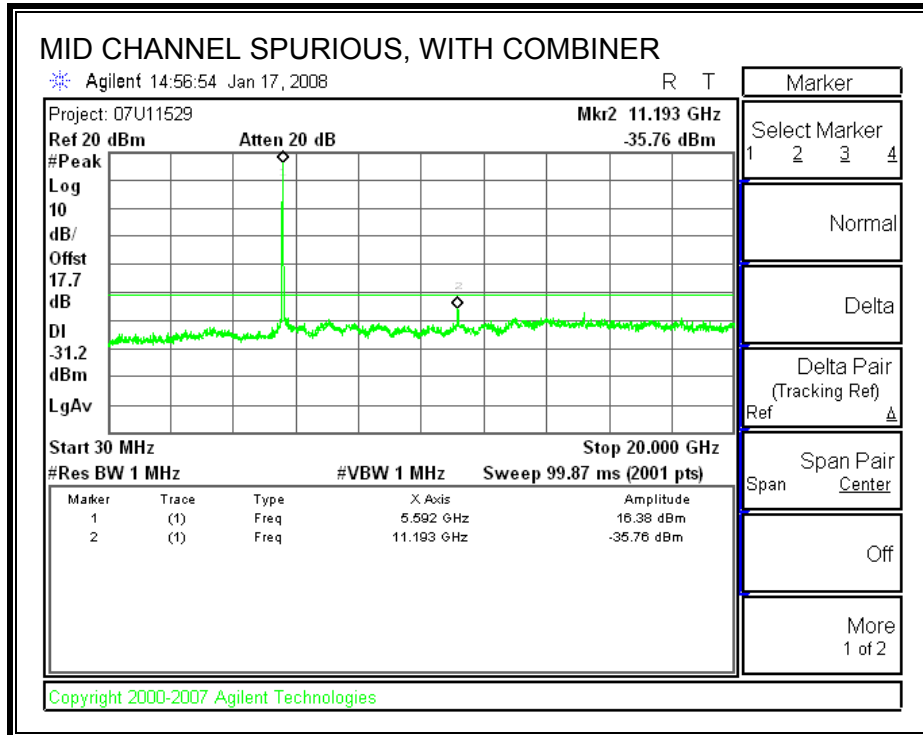

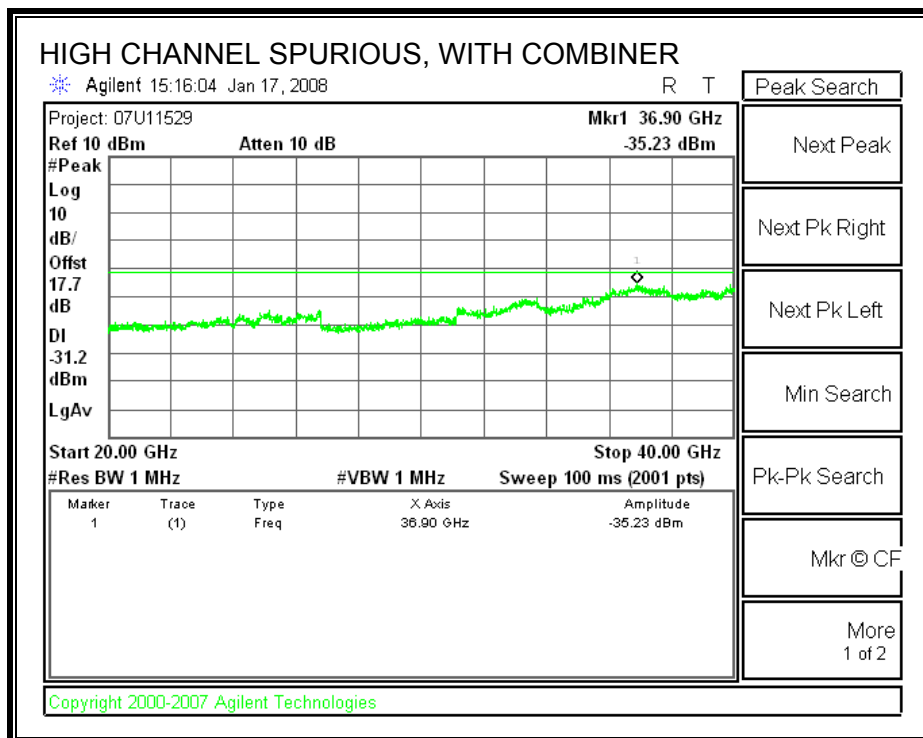
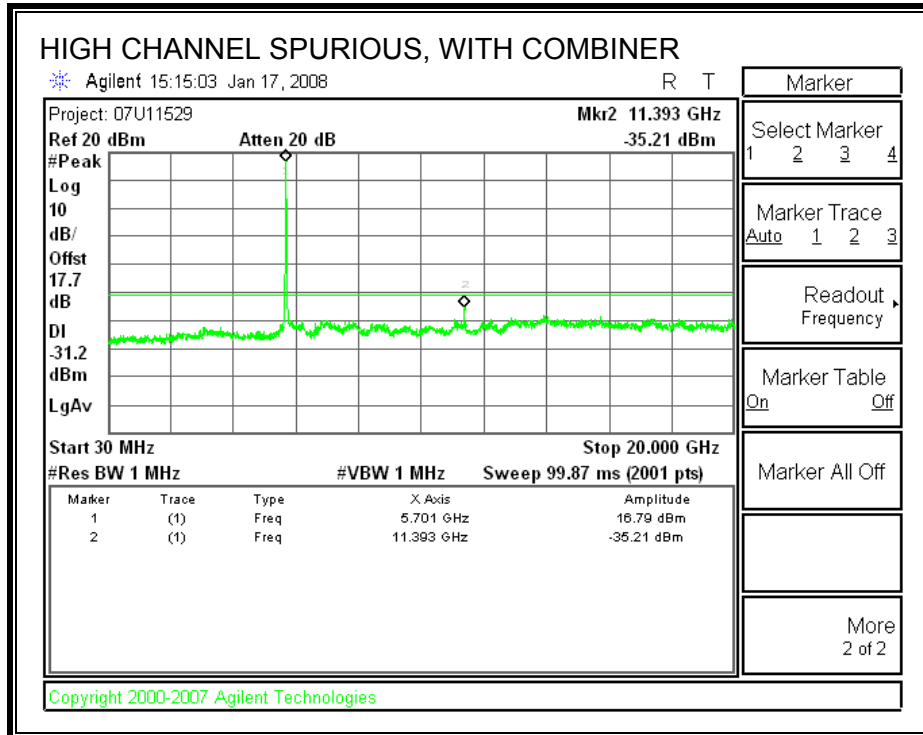

9.3. 802.11n HT40 MODE

9.3.1. 26 dB and 99% BANDWIDTH

LIMITS

None; for reporting purposes only.

TEST PROCEDURE

The transmitter outputs are connected to the spectrum analyzer via a combiner. The RBW is set to 1% to 3% of the measured bandwidth. The VBW is set to 3 times the RBW. The sweep time is coupled. The spectrum analyzer internal bandwidth function is utilized.

RESULTS

Channel	Frequency (MHz)	26 dB Bandwidth (MHz)	99% Bandwidth (MHz)
Low	5510	38.144	36.0471
Middle	5590	70.696	36.7352
High	5670	69.461	36.7225

26 dB and 99% BANDWIDTH

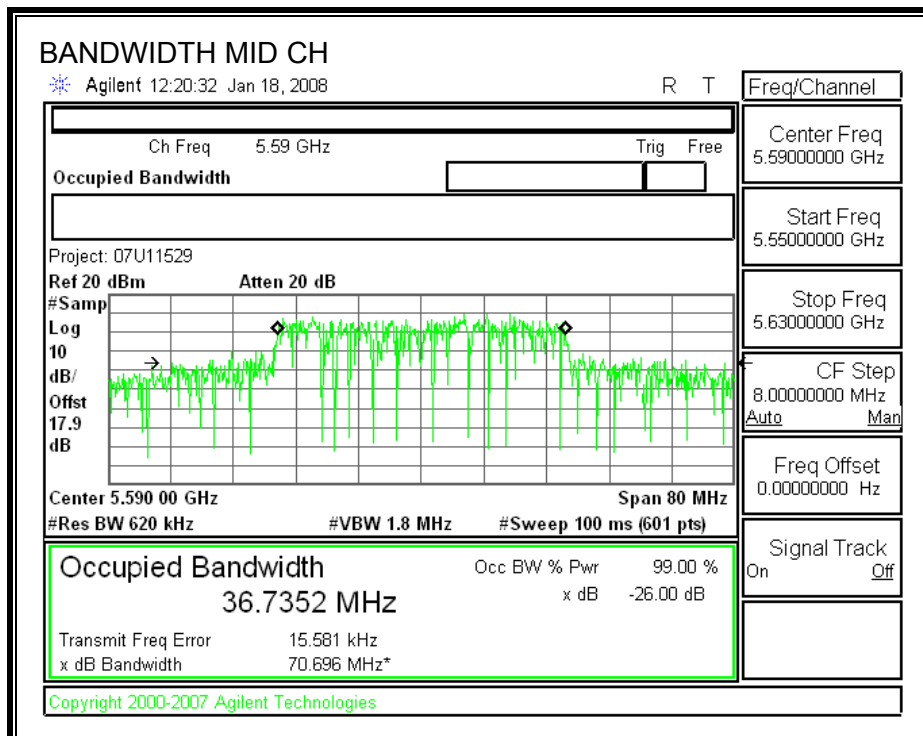
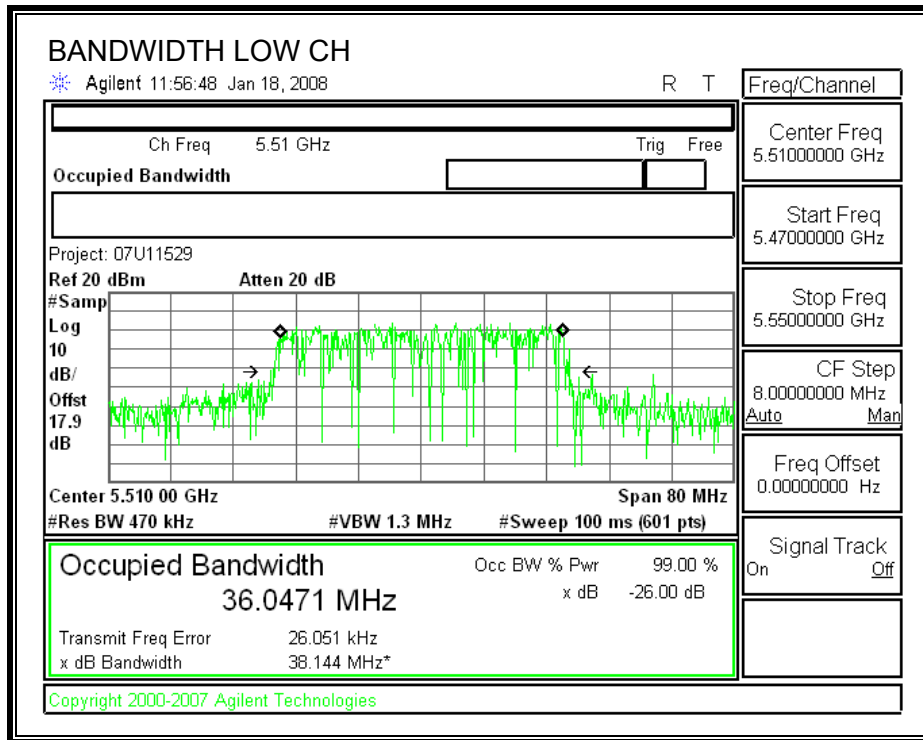

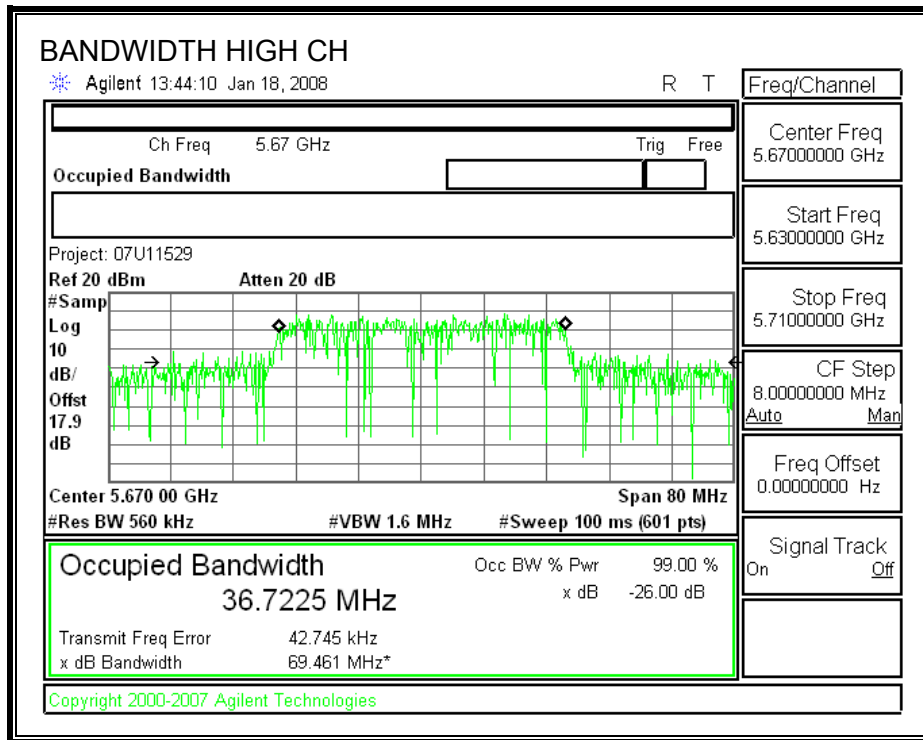

9.3.2. OUTPUT POWER

LIMITS

FCC §15.407 (a) (2)

IC RSS-210 A9.2 (2)

For the 5.47-5.725 GHz band, the maximum conducted output power over the frequency band of operation shall not exceed the lesser of 250 mW or $11 \text{ dBm} + 10 \log B$, where B is the 26-dB emission bandwidth in MHz. If transmitting antennas of directional gain greater than 6 dBi are used, both the peak transmit power and the peak power spectral density shall be reduced by the amount in dB that the directional gain of the antenna exceeds 6 dBi.

TEST PROCEDURE

The test is performed in accordance with FCC Public Notice: APPENDIX A Guidelines for Assessing Unlicensed National Information Infrastructure (U-NII) Devices – Part 15, Subpart E, August 2002.

The transmitter output operates continuously therefore Method # 1 is used.

RESULTS

6dBi Antenna Gain

Limit

Channel	Frequency (MHz)	Fixed Limit (dBm)	B (MHz)	11 + 10 Log B Limit (dBm)	Antenna Gain (dBi)	Limit (dBm)
Low	5510	24	38.144	26.81	6.00	24.00
Mid	5590	24	70.696	29.49	6.00	24.00
High	5670	24	69.461	29.42	6.00	24.00

Individual Chain Results

Channel	Frequency (MHz)	Chain 0 Power (dBm)	Chain 1 Power (dBm)	Total Power (dBm)	Limit (dBm)	Margin (dB)
Low	5510	15.61	15.60	18.62	24.00	-5.38
Mid	5590	18.83	18.88	21.87	24.00	-2.13
High	5670	18.69	18.70	21.71	24.00	-2.29

7.21dBi Antenna Gain

Note: Low, mid & high channels still meet the Peak Power and PSD limits of high antenna gain. These channels utilize the same power level for all antennas. The channel power data in table below is from 6dBi data

Limit

Channel	Frequency (MHz)	Fixed Limit (dBm)	B (MHz)	11 + 10 Log B Limit (dBm)	Antenna Gain (dBi)	Limit (dBm)
Low	5510	24	38.144	26.81	7.21	22.79
Mid	5590	24	70.696	29.49	7.21	22.79
High	5670	24	69.461	29.42	7.21	22.79

Individual Chain Results

Channel	Frequency (MHz)	Chain 1 Power (dBm)	Chain 2 Power (dBm)	Total Power (dBm)	Limit (dBm)	Margin (dB)
Low	5510	15.61	15.60	18.62	22.79	-4.17
Mid	5590	18.83	18.88	21.87	22.79	-0.92
High	5670	18.69	18.70	21.71	22.79	-1.08

CHAIN 0 OUTPUT POWER (6dBi & 7.21dBi Antenna Gains)

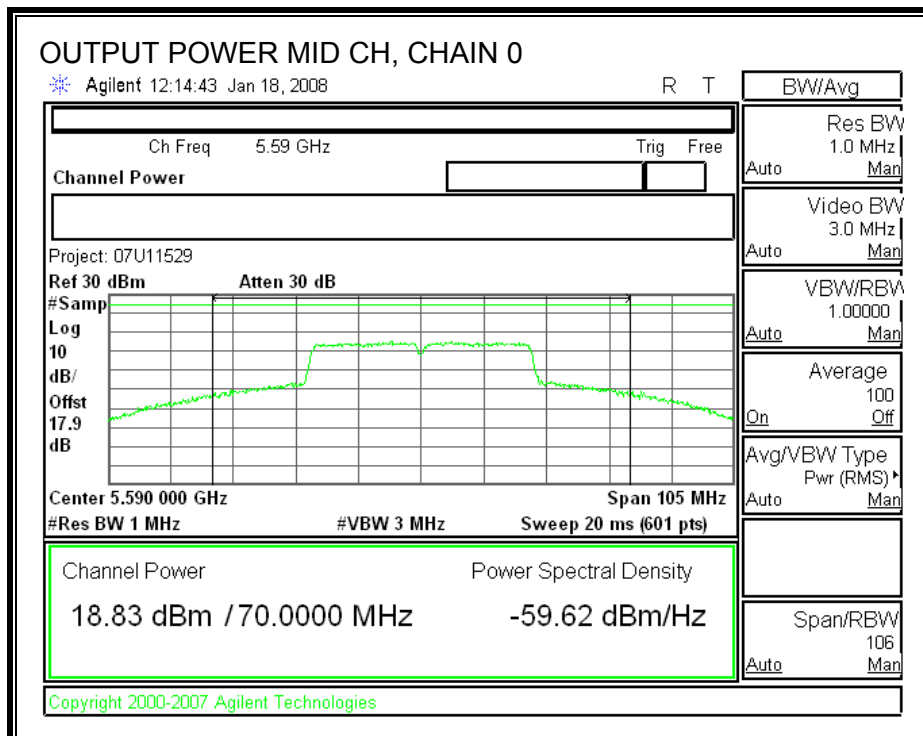
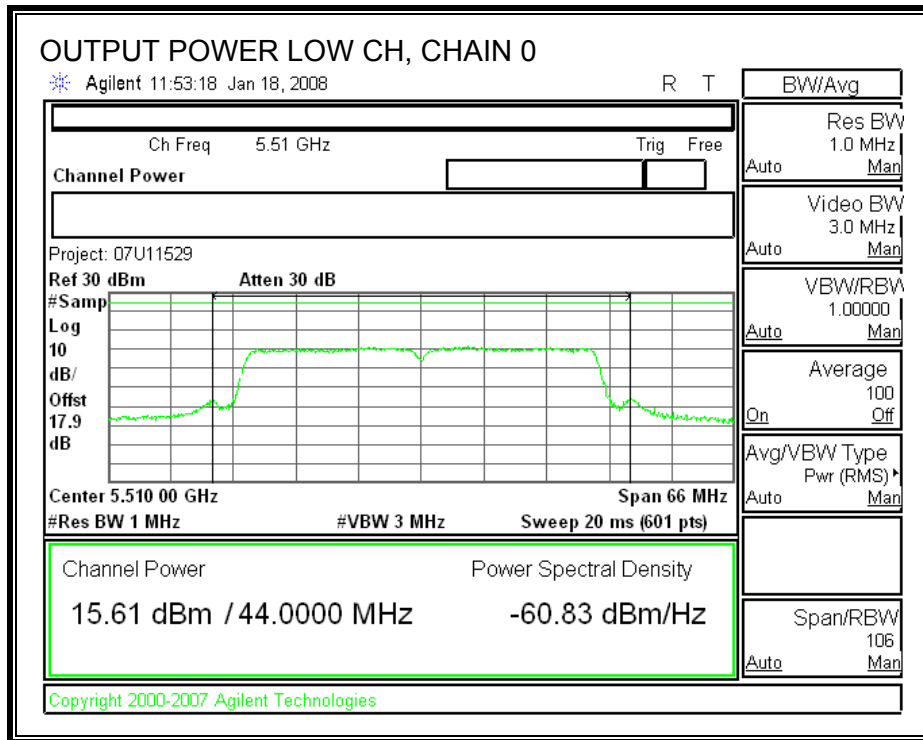

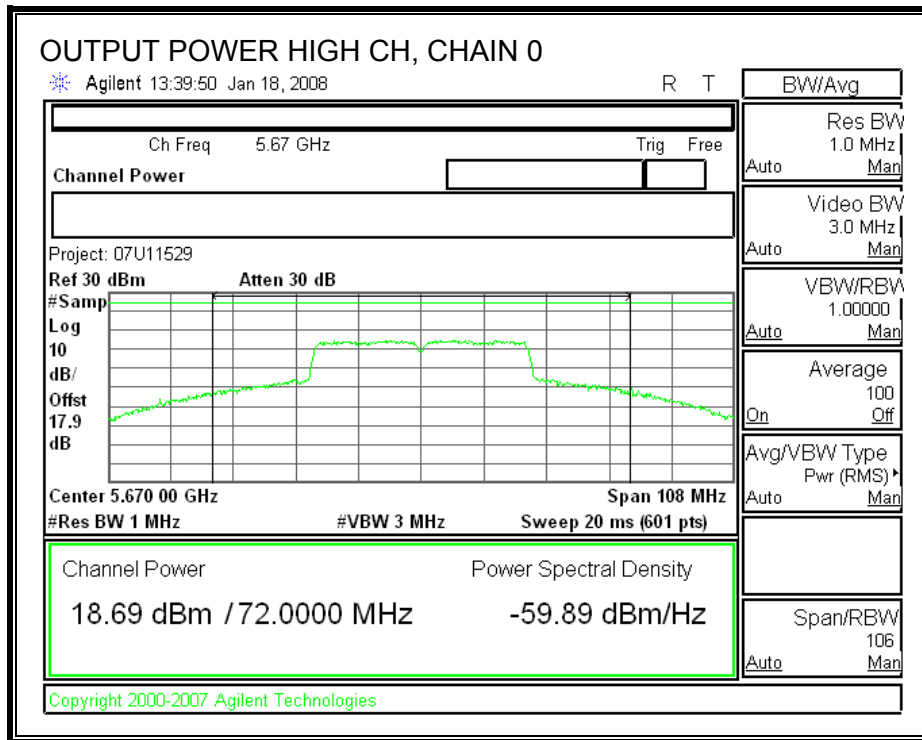

CHAIN 1 OUTPUT POWER (6dBi & 7.21dBi Antenna Gains)

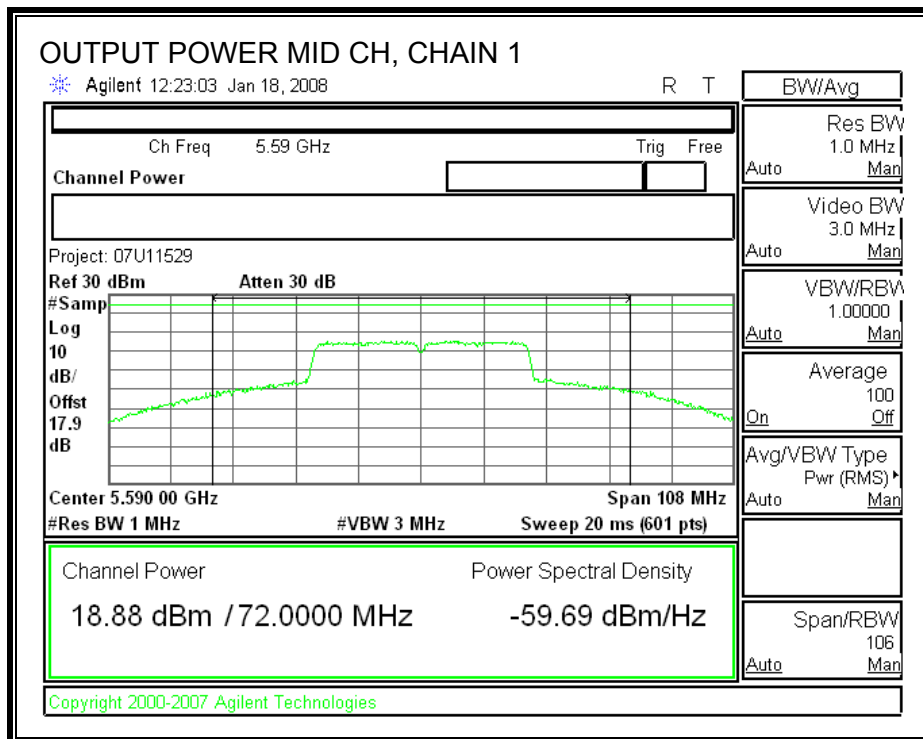
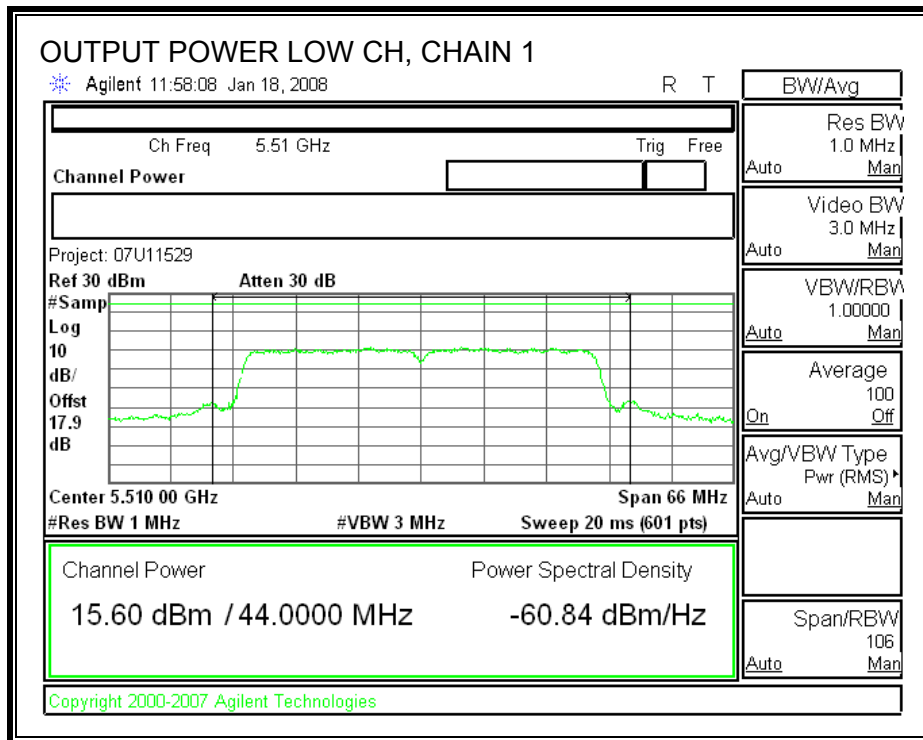

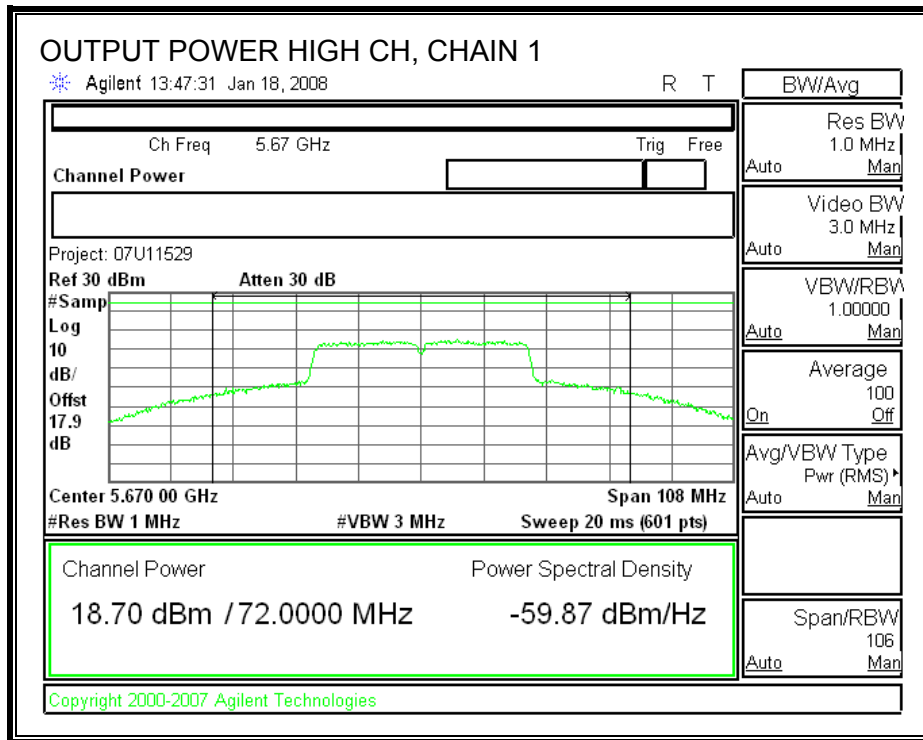

9.3.3. PEAK POWER SPECTRAL DENSITY

LIMITS

FCC §15.407 (a) (2)

IC RSS-210 A9.2 (2)

For the 5.47-5.725 GHz band, the peak power spectral density shall not exceed 11 dBm in any 1 MHz band. If transmitting antennas of directional gain greater than 6 dBi are used, both the peak transmit power and the peak power spectral density shall be reduced by the amount in dB that the directional gain of the antenna exceeds 6 dBi.

The maximum antenna gain is less than or equal to 6 dBi, therefore the limit is 11 dBm.

The maximum antenna gain is 7.21 dBi, therefore the limit is 9.79 dBm.

TEST PROCEDURE

The test is performed in accordance with FCC Public Notice: APPENDIX A Guidelines for Assessing Unlicensed National Information Infrastructure (U-NII) Devices – Part 15, Subpart E, August 2002. PPSD method #2 was used.

RESULTS

6dBi Antenna Gain

Channel	Frequency (MHz)	PPSD With Combiner (dBm)	Limit (dBm)	Margin (dB)
Low	5510	4.780	11	-6.22
Middle	5590	8.836	11	-2.16
High	5670	8.857	11	-2.14

7.21dBi Antenna Gain

Note: The Low, mid & high channels still meet the PPSD limits of high antenna gain. These channels utilize the same power level for all antennas. The channel power data in table below is from 6dBi data

Channel	Frequency (MHz)	PPSD With Combiner (dBm)	Limit (dBm)	Margin (dB)
Low	5510	4.78	9.79	-5.01
Middle	5590	8.84	9.79	-0.95
High	5670	8.86	9.79	-0.93

POWER SPECTRAL DENSITY WITH COMBINER (6dBi & 7.21dBi Antenna Gains)

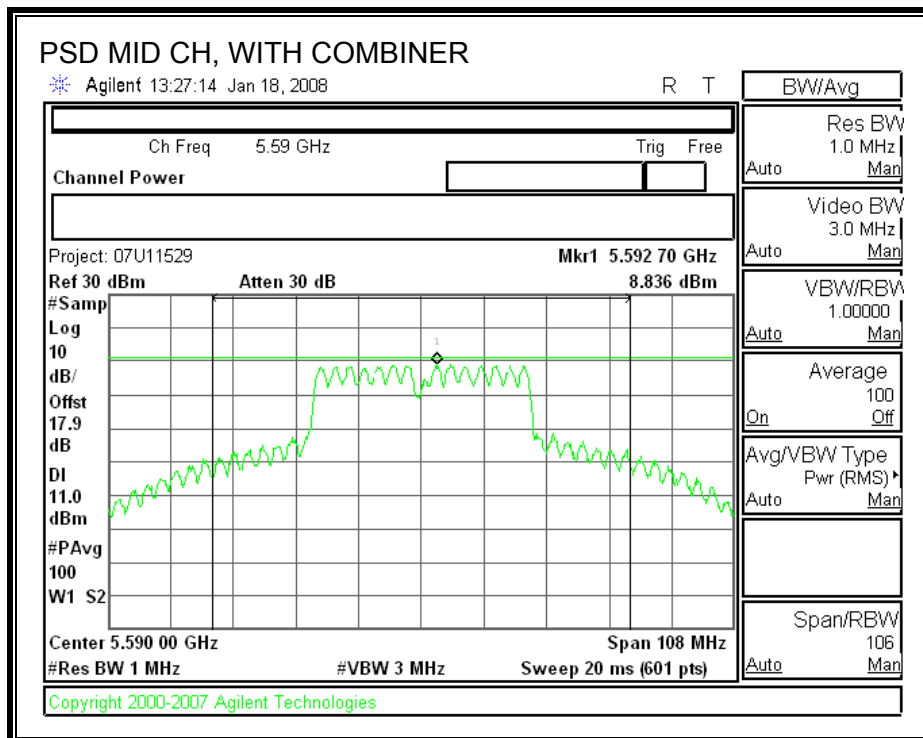
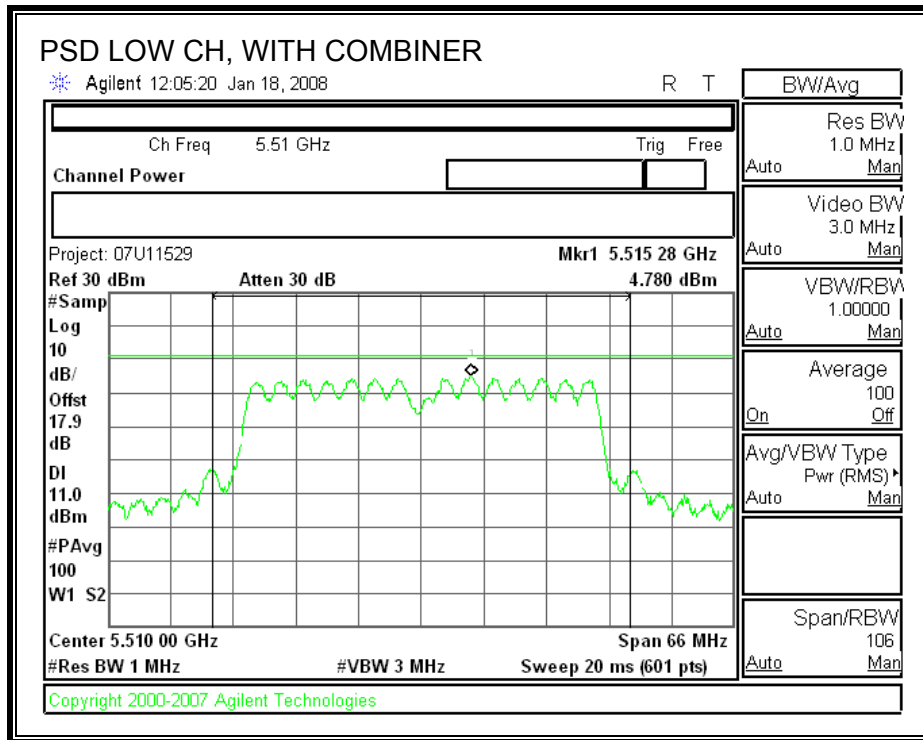

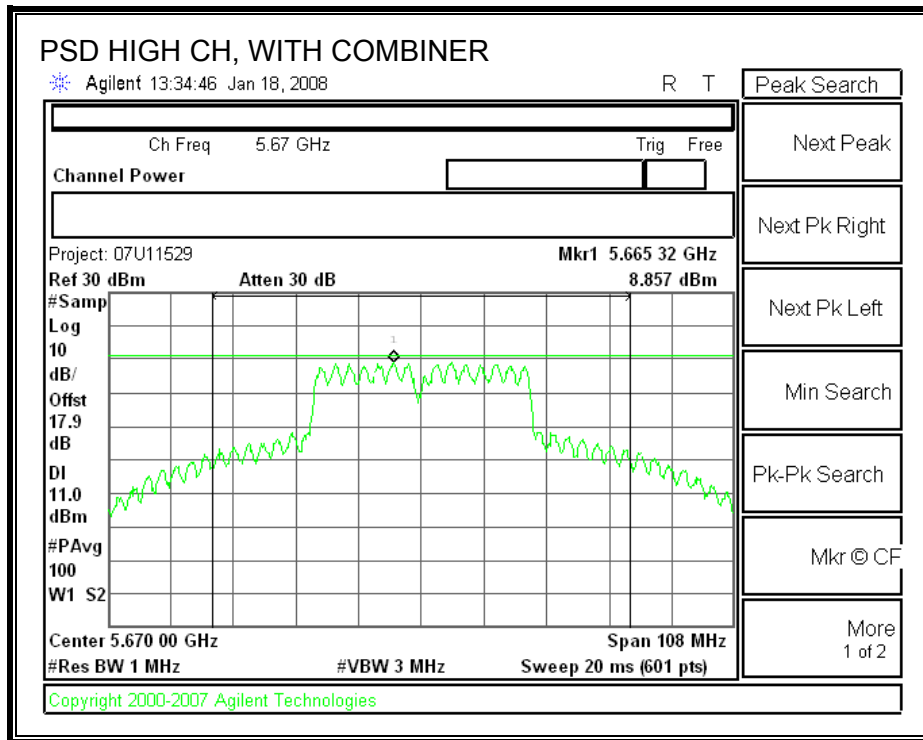

9.3.4. PEAK EXCURSION

LIMITS

FCC §15.407 (a) (6)

The ratio of the peak excursion of the modulation envelope (measured using a peak hold function) to the peak transmit power (measured as specified above) shall not exceed 13 dB across any 1 MHz bandwidth or the emission bandwidth whichever is less.

TEST PROCEDURE

The transmitter outputs are connected to the spectrum analyzer via a combiner.

The test is performed in accordance with FCC Public Notice: APPENDIX A Guidelines for Assessing Unlicensed National Information Infrastructure (U-NII) Devices – Part 15, Subpart E, August 2002.

Since Method # 1 was used for peak power measurements, Method # 1 settings are used for the second PPSD trace.

RESULTS

Chain 1

Channel	Frequency (MHz)	Peak Excursion (dB)	Limit (dB)	Margin (dB)
Low	5510	10.76	13	-2.24
Middle	5590	9.88	13	-3.12
High	5670	10.14	13	-2.86

Chain 2

Channel	Frequency (MHz)	Peak Excursion (dB)	Limit (dB)	Margin (dB)
Low	5510	10.01	13	-2.99
Middle	5590	11.15	13	-1.85
High	5670	11.18	13	-1.82

PEAK EXCURSION (CHAIN 0)

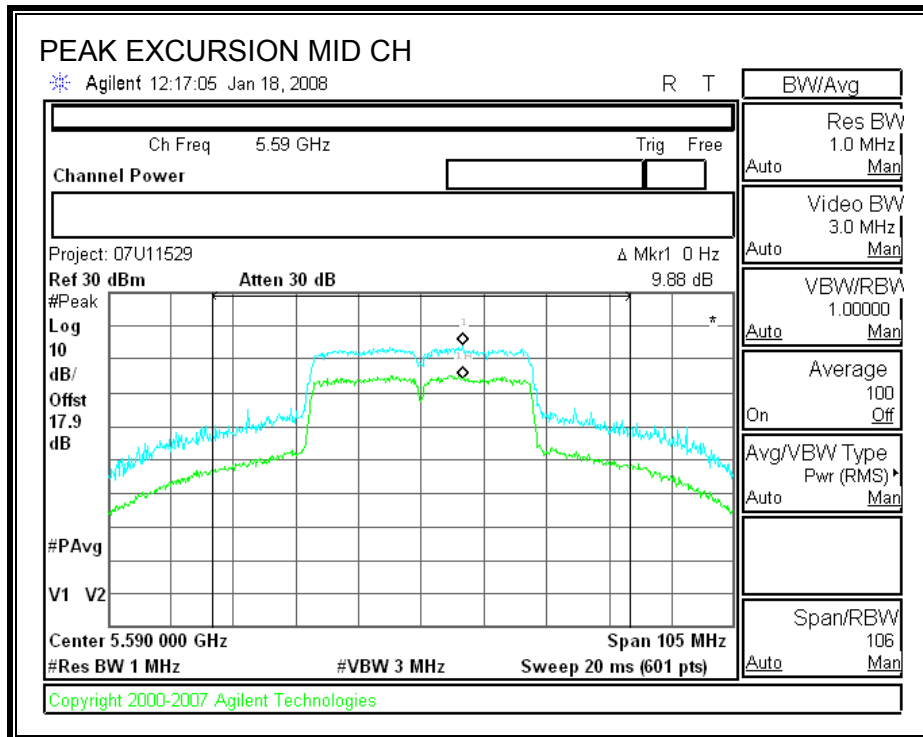
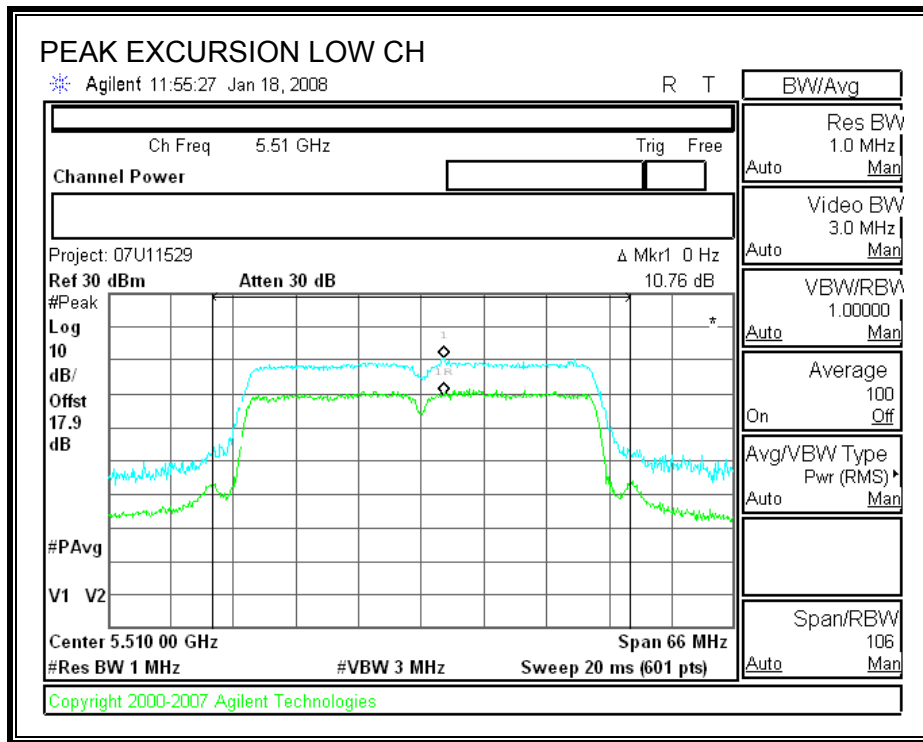

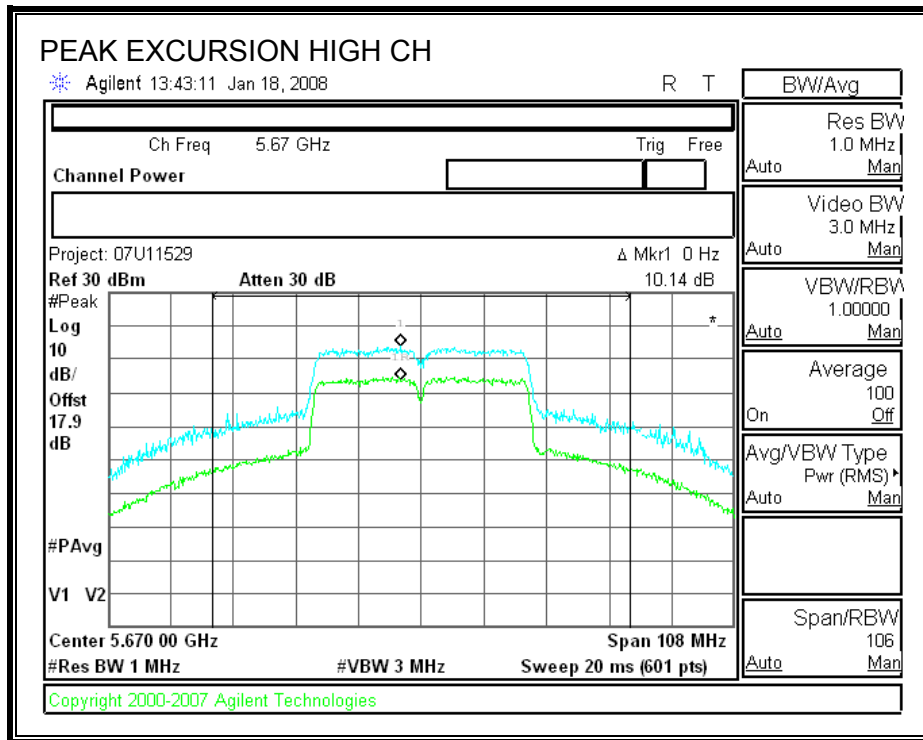

PEAK EXCURSION (CHAIN 1)

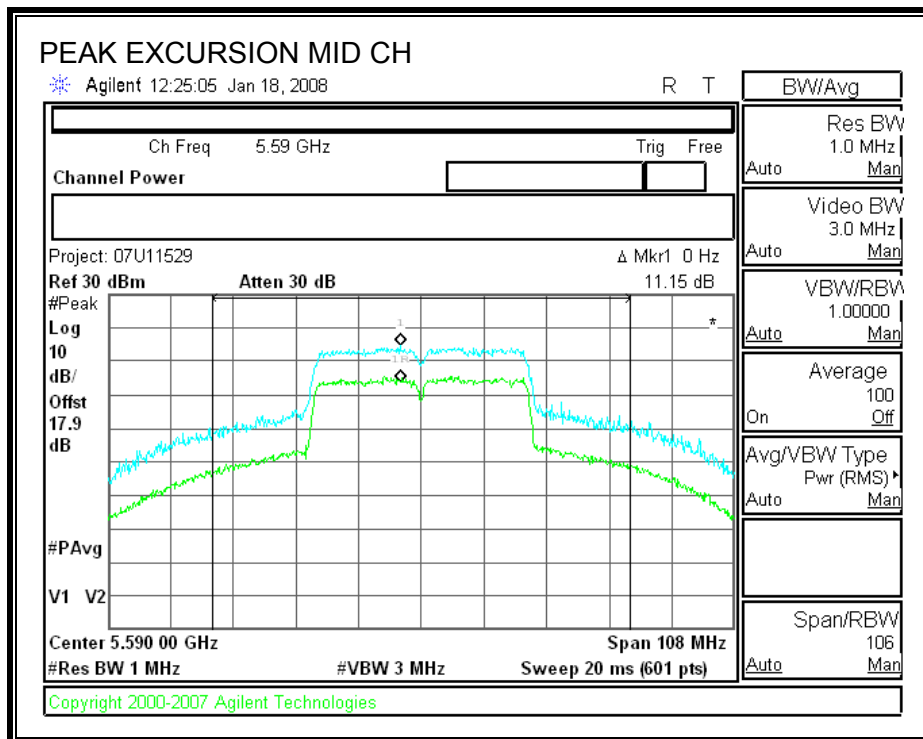
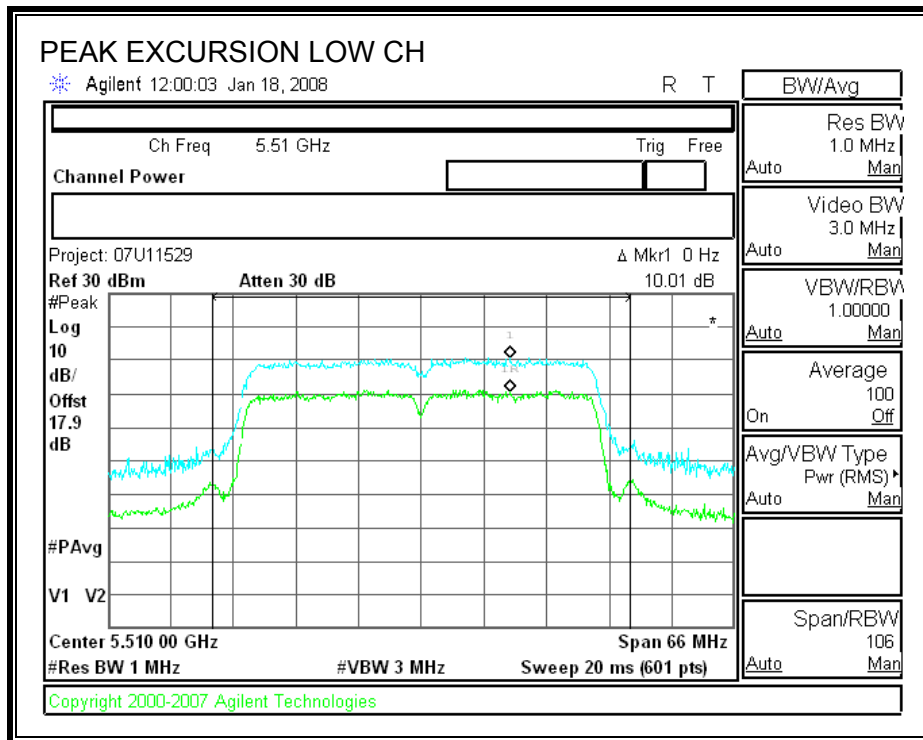

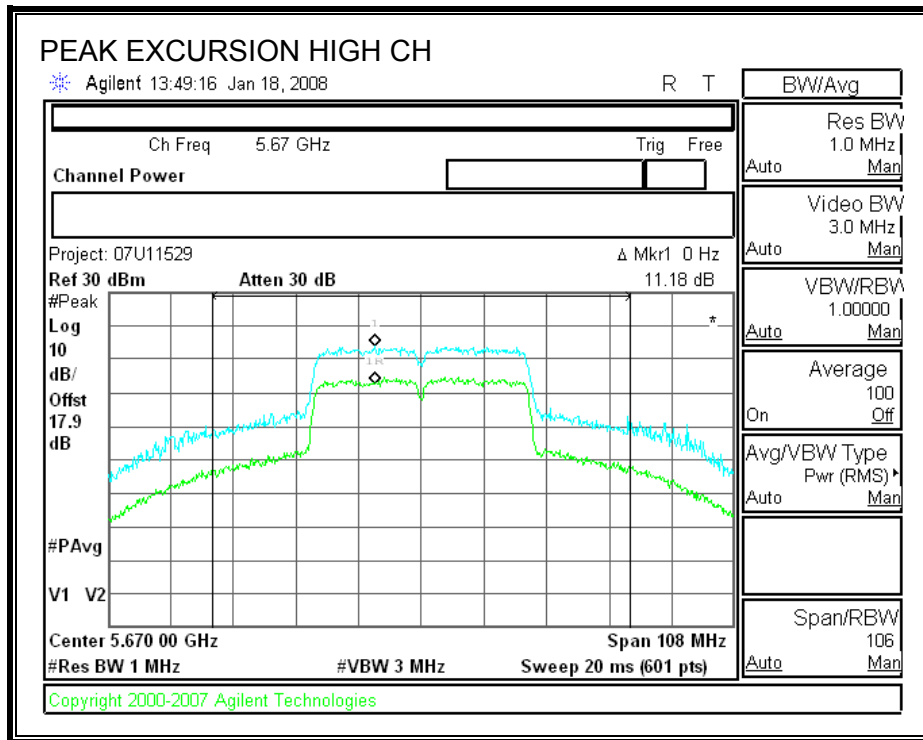

9.3.5. CONDUCTED SPURIOUS EMISSIONS

LIMITS

FCC §15.407 (b) (3)

IC RSS-210 A9.3 (3)

For transmitters operating in the 5.47-5.725 GHz band: all emissions outside of the 5.47-5.725 GHz band shall not exceed an EIRP of -27 dBm / MHz.

Limit line = -27 - EUT Antenna Gain

TEST PROCEDURE

Conducted RF measurements of the transmitter output are made to confirm that the EUT antenna port conducted emissions meet the specified limit and to identify any spurious signals that require further investigation or measurements on the radiated emissions site.

The transmitter output is connected to the spectrum analyzer. The resolution bandwidth is set to 1 MHz. The video bandwidth is set to 1 MHz. Peak detection measurements are compared to the average EIRP limit, adjusted for the maximum antenna gain. If necessary, additional average detection measurements are made.

Measurements are made over the 30 MHz to 40 GHz range with the transmitter set to the lowest, middle, and highest channels.

RESULTS

SPURIOUS EMISSIONS WITH COMBINER

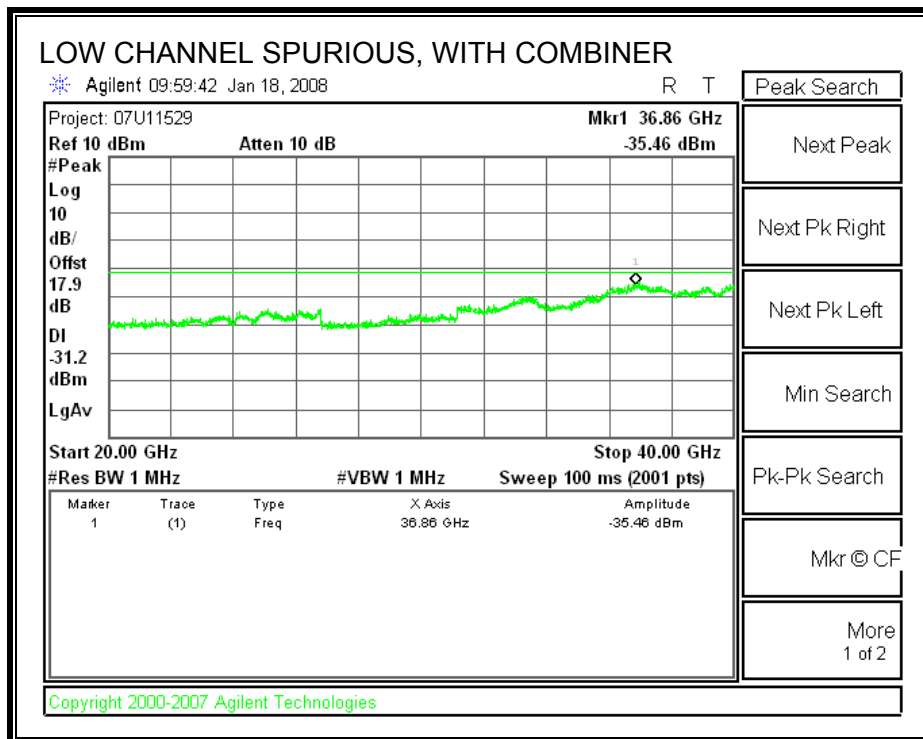
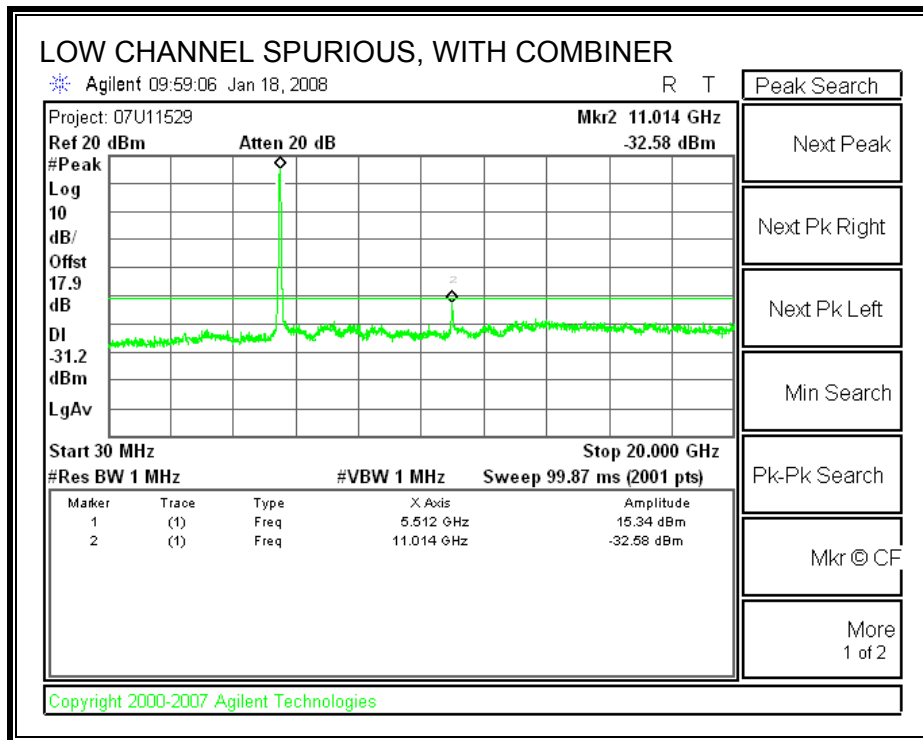

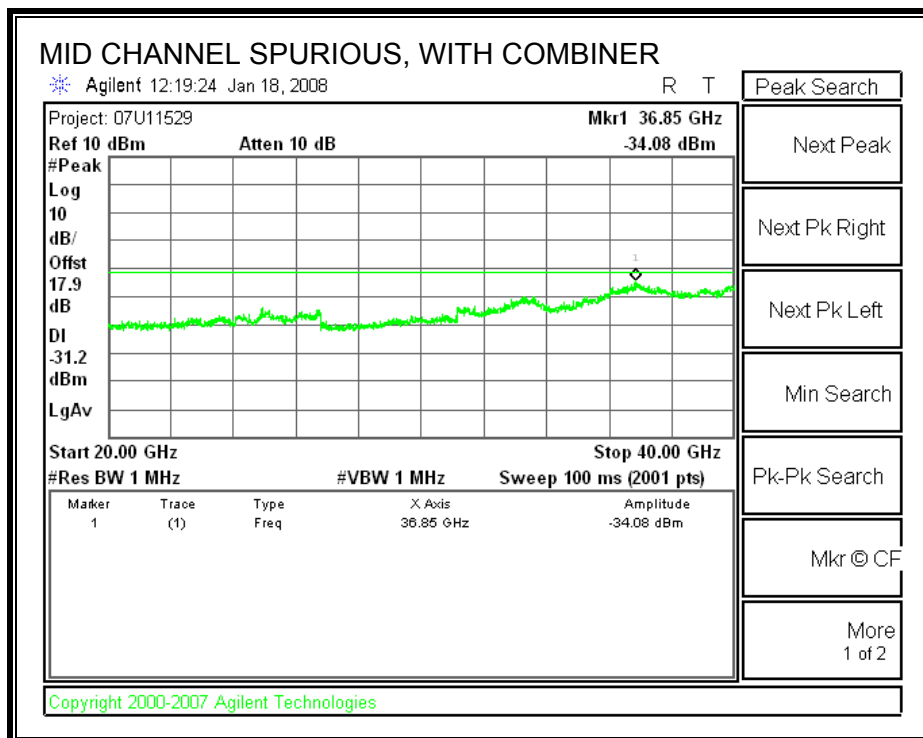
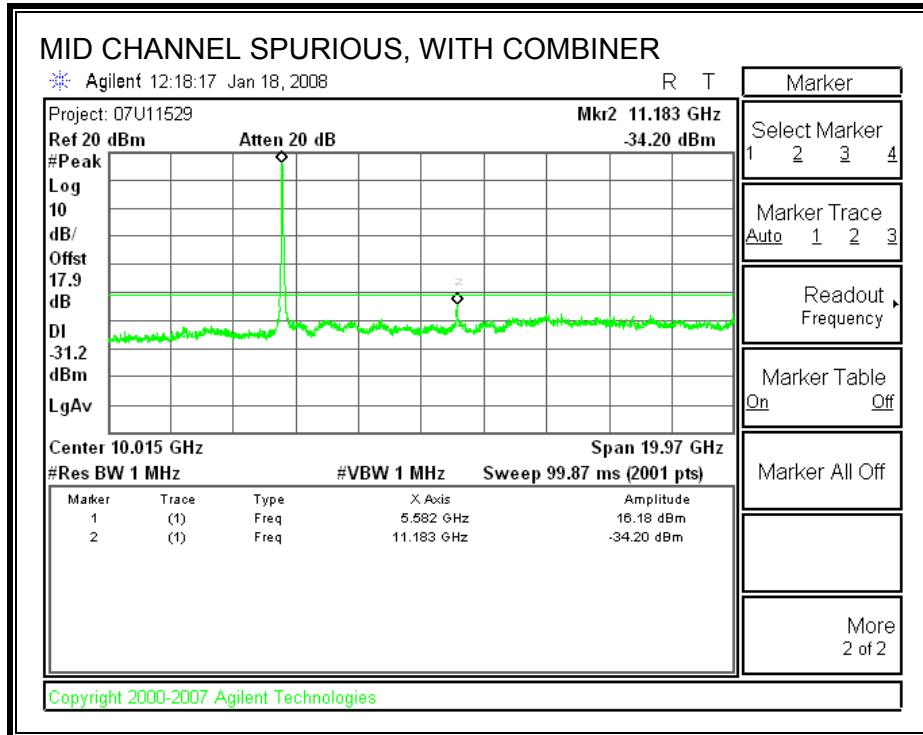

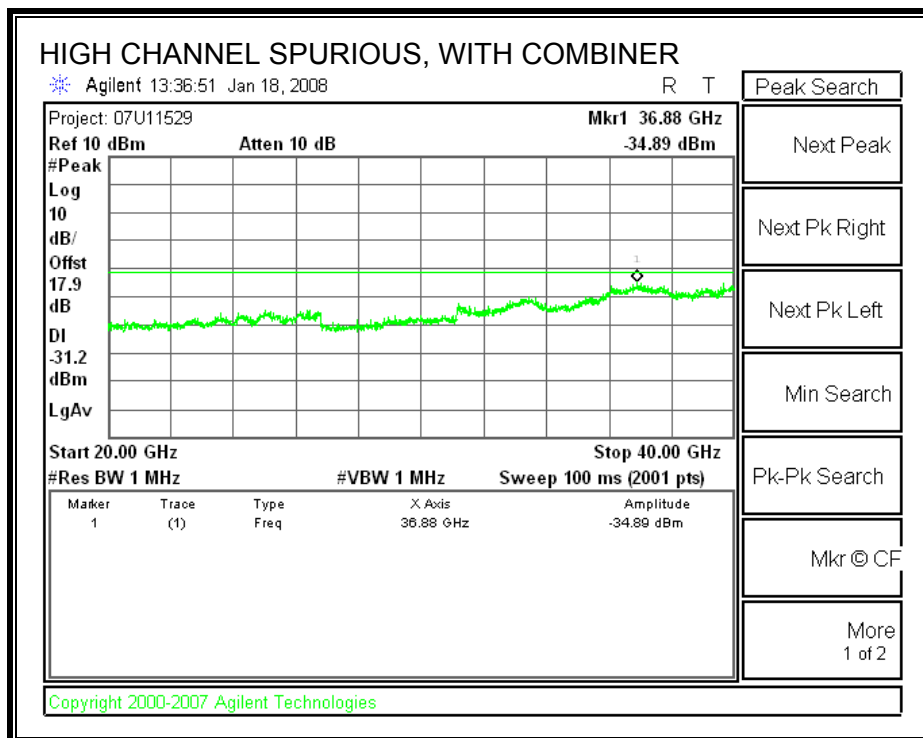
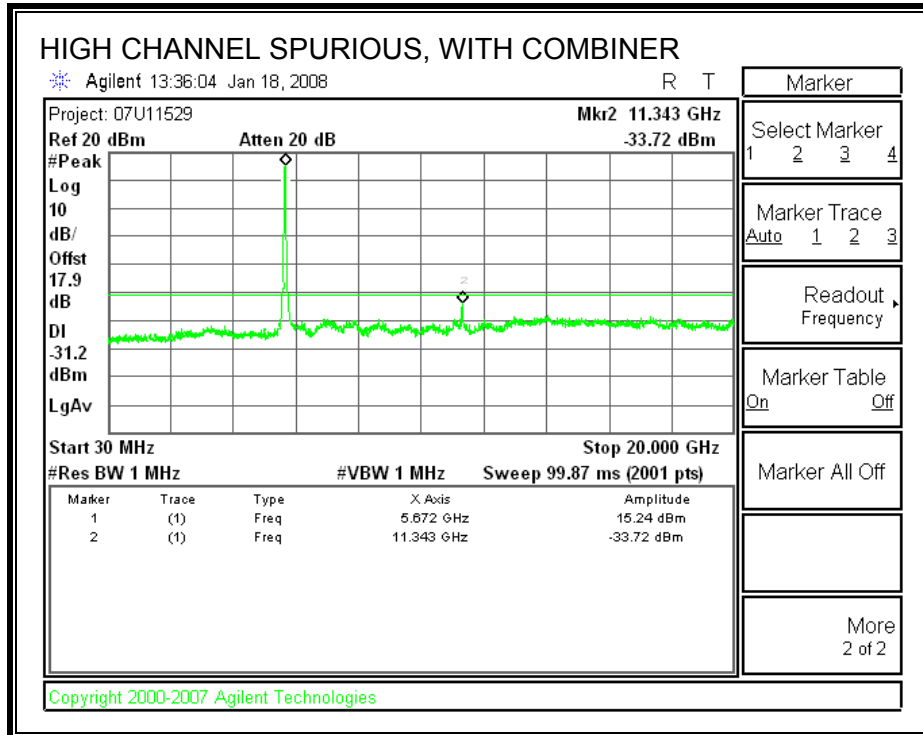

10. RADIATED TEST RESULTS

10.1. LIMITS AND PROCEDURE

LIMITS

FCC §15.205 and §15.209

IC RSS-210 Clause 2.6 (Transmitter)

IC RSS-GEN Clause 6 (Receiver)

Frequency Range (MHz)	Field Strength Limit ($\mu\text{V}/\text{m}$) at 3 m	Field Strength Limit (dB $\mu\text{V}/\text{m}$) at 3 m
30 - 88	100	40
88 - 216	150	43.5
216 - 960	200	46
Above 960	500	54

TEST PROCEDURE

The EUT is placed on a non-conducting table 80 cm above the ground plane. The antenna to EUT distance is 3 meters. The EUT is configured in accordance with ANSI C63.4. The EUT is set to transmit in a continuous mode.

For measurements below 1 GHz the resolution bandwidth is set to 100 kHz for peak detection measurements or 120 kHz for quasi-peak detection measurements. Peak detection is used unless otherwise noted as quasi-peak.

For measurements above 1 GHz the resolution bandwidth is set to 1 MHz, then the video bandwidth is set to 1 MHz for peak measurements and 10 Hz for average measurements.

The spectrum from 30 MHz to 40 GHz is investigated with the transmitter set to the lowest, middle, and highest channels in the 5 GHz band.

The frequency range of interest is monitored at a fixed antenna height and EUT azimuth. The EUT is rotated through 360 degrees to maximize emissions received. The antenna is scanned from 1 to 4 meters above the ground plane to further maximize the emission. Measurements are made with the antenna polarized in both the vertical and the horizontal positions.

10.2. TRANSMITTER ABOVE 1 GHZ FOR THE BAND 5.15–5.25 GHZ

10.2.1. 802.11a MODE

RESTRICTED BANDEDGE (LOW CHANNEL, HORIZONTAL)

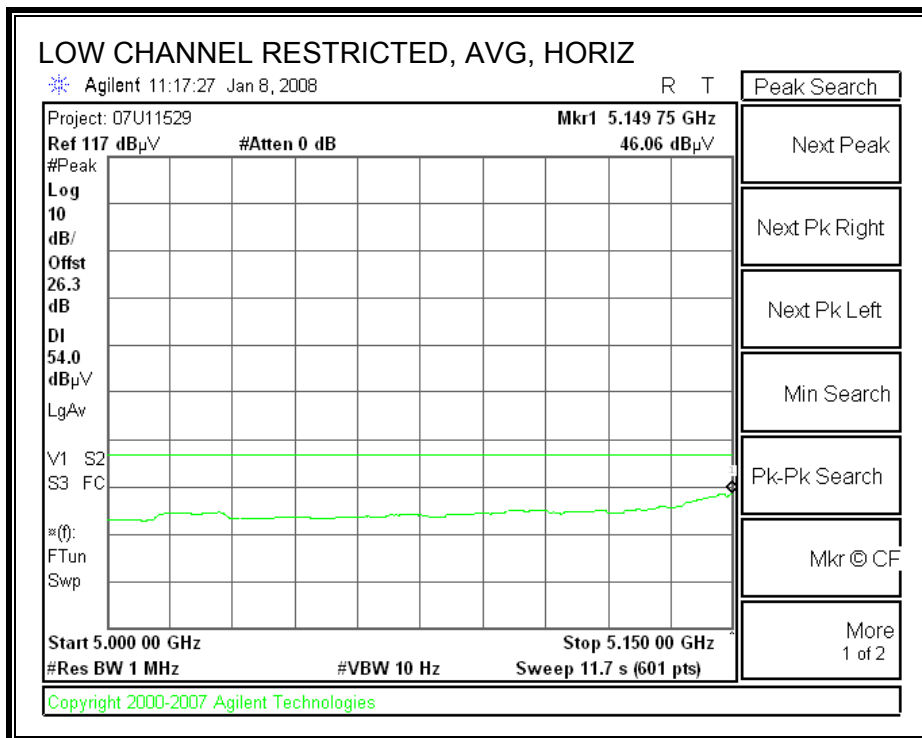
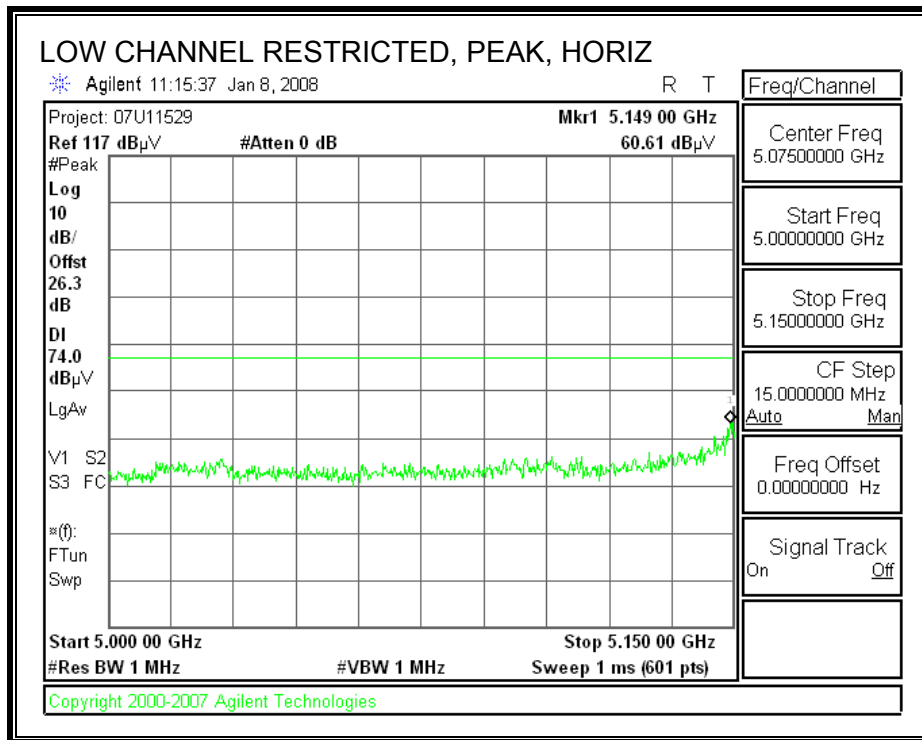

RESTRICTED BANDEDGE (LOW CHANNEL, VERTICAL)

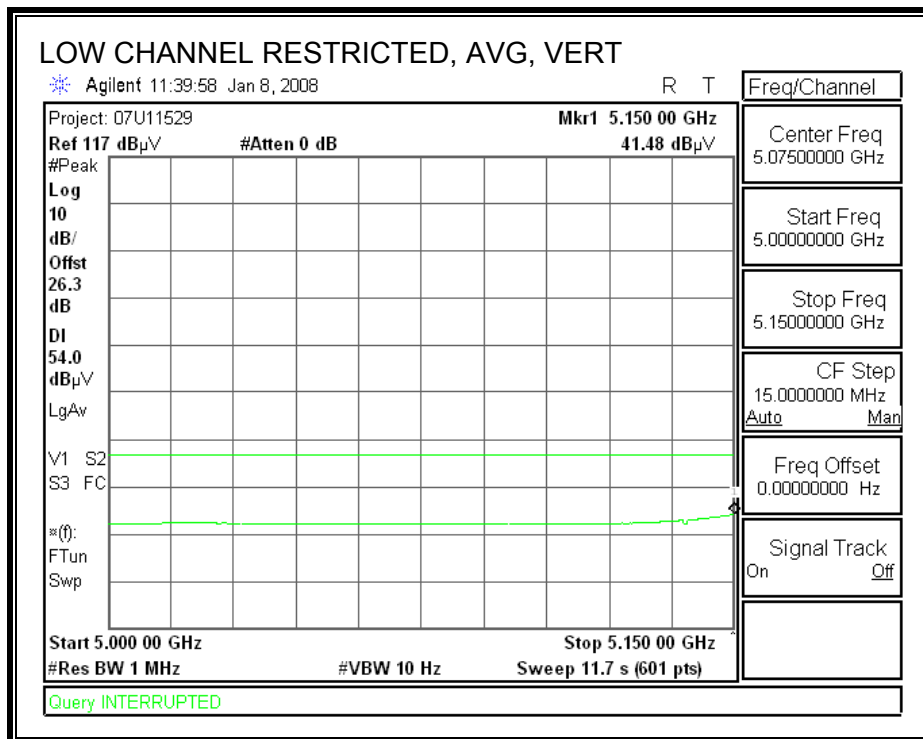
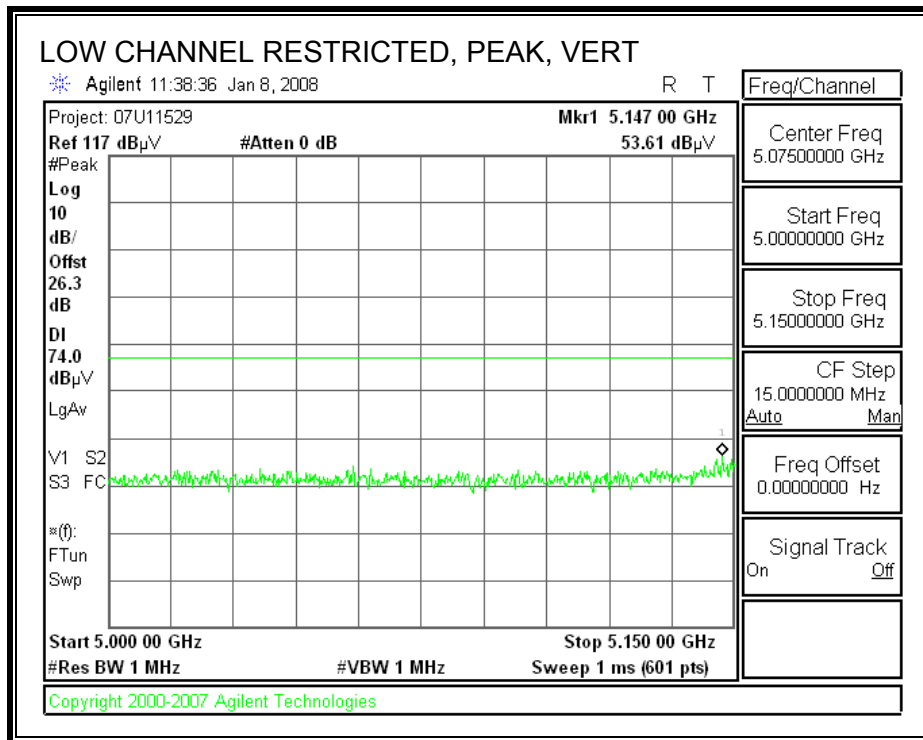

AUTHORIZED BANDEDGE (HIGH CHANNEL)

The EUT passes Conducted Spurious test; therefore this test is not performed.

HARMONICS AND SPURIOUS EMISSIONS

High Frequency Measurement
 Compliance Certification Services, Fremont 3m Chamber

Company: Broadcom
 Project #: 07U11529
 Date: 01/09/2008
 Test Engineer: Vien Tran
 Configuration: EUT with 5.6dBi Antenna
 Mode: Tx 5.2 GHz_5150-5250 MHz_11a Legacy

Test Equipment:

Horn 1-18GHz T60; S/N: 2238 @3m	Pre-amplifier 1-26GHz T34 HP 8449B	Pre-amplifier 26-40GHz	Horn > 18GHz	Limit FCC 15.205
Hi Frequency Cables				
2 foot cable	3 foot cable Vien 187215002	12 foot cable Ninous 208946002	HPF HPF_7.6GHz	Reject Filter

Peak Measurements
 RBW=VBW=1MHz
 Average Measurements
 RBW=1MHz ; VBW=10Hz

f GHz	Dist (m)	Read Pk dBuV	Read Avg dBuV	AF dB/m	CL dB	Amp dB	D Corr dB	Filtr dB	Peak dBuV/m	Avg dBuV/m	Pk Lim dBuV/m	Avg Lim dBuV/m	Pk Mar dB	Avg Mar dB	Notes (V/H)
LOW CHANNEL, 5180 MHz															
15.540	3.0	50.4	40.8	38.0	5.1	-32.2	0.0	0.7	62.0	52.4	74	54	-12.0	-1.6	H
15.540	3.0	49.6	39.0	38.0	5.1	-32.2	0.0	0.7	61.2	50.6	74	54	-12.8	-3.4	V
MID CHANNEL, 5200 MHz															
15.600	3.0	50.9	41.1	38.0	5.1	-32.2	0.0	0.7	62.5	52.7	74	54	-11.5	-1.3	H
15.600	3.0	49.8	39.1	38.0	5.1	-32.2	0.0	0.7	61.4	50.7	74	54	-12.6	-3.3	V
HI CHANNEL, 5240 MHz															
15.720	3.0	51.3	41.5	37.9	5.1	-32.2	0.0	0.7	62.9	53.1	74	54	-11.1	-0.9	H
15.720	3.0	49.9	39.4	37.9	5.1	-32.2	0.0	0.7	61.5	51.0	74	54	-12.5	-3.0	H

No other emissions were detected above system noise floor

f	Measurement Frequency	Amp	Preamp Gain	Avg Lim	Average Field Strength Limit
Dist	Distance to Antenna	D Corr	Distance Correct to 3 meters	Pk Lim	Peak Field Strength Limit
Read	Analyzer Reading	Avg	Average Field Strength @ 3 m	Avg Mar	Margin vs. Average Limit
AF	Antenna Factor	Peak	Calculated Peak Field Strength	Pk Mar	Margin vs. Peak Limit
CL	Cable Loss	HPF	High Pass Filter		

10.2.2. 802.11n HT20 MODE

RESTRICTED BANDEDGE (LOW CHANNEL, HORIZONTAL)

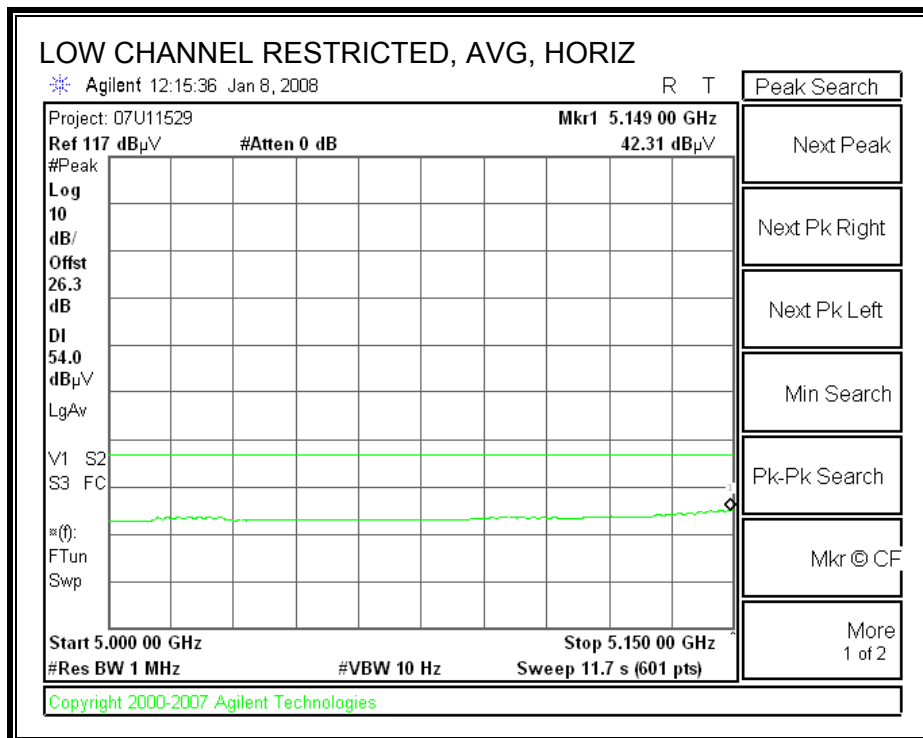
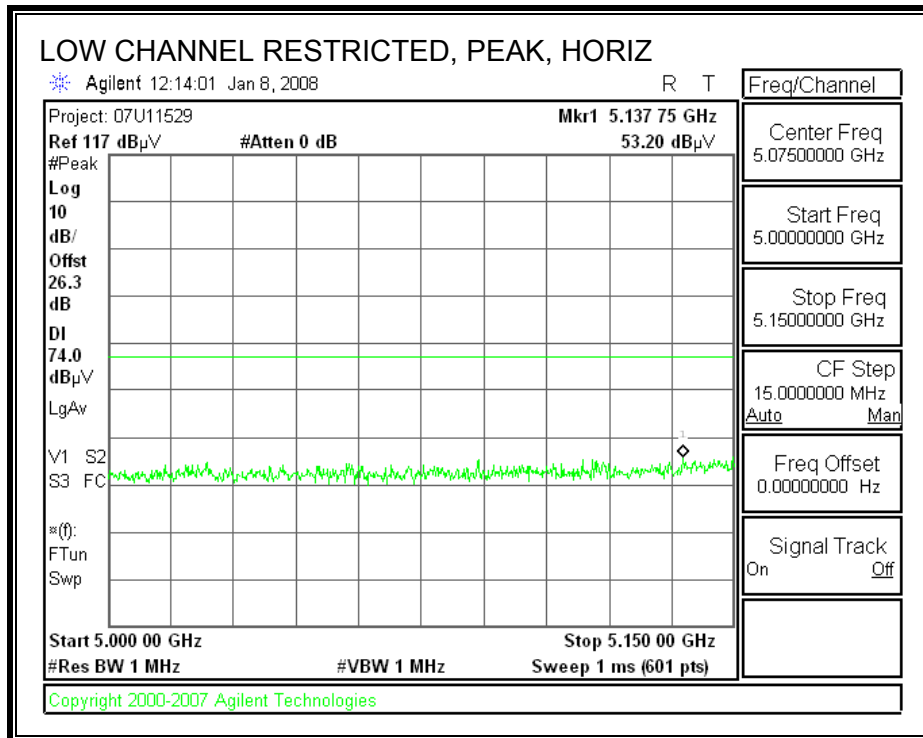

RESTRICTED BANDEDGE (LOW CHANNEL, VERTICAL)

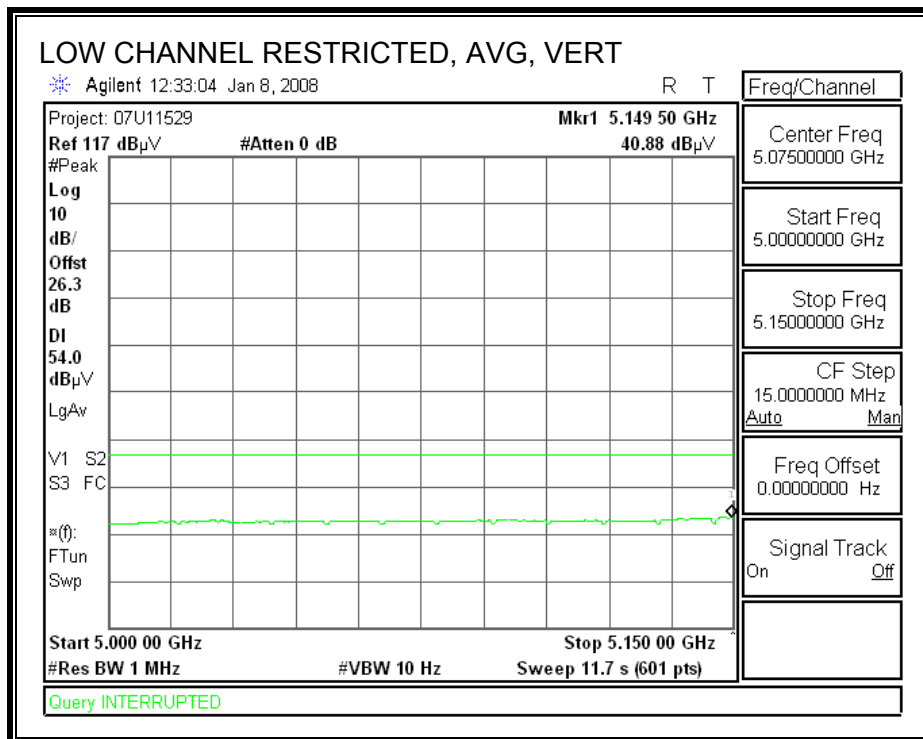
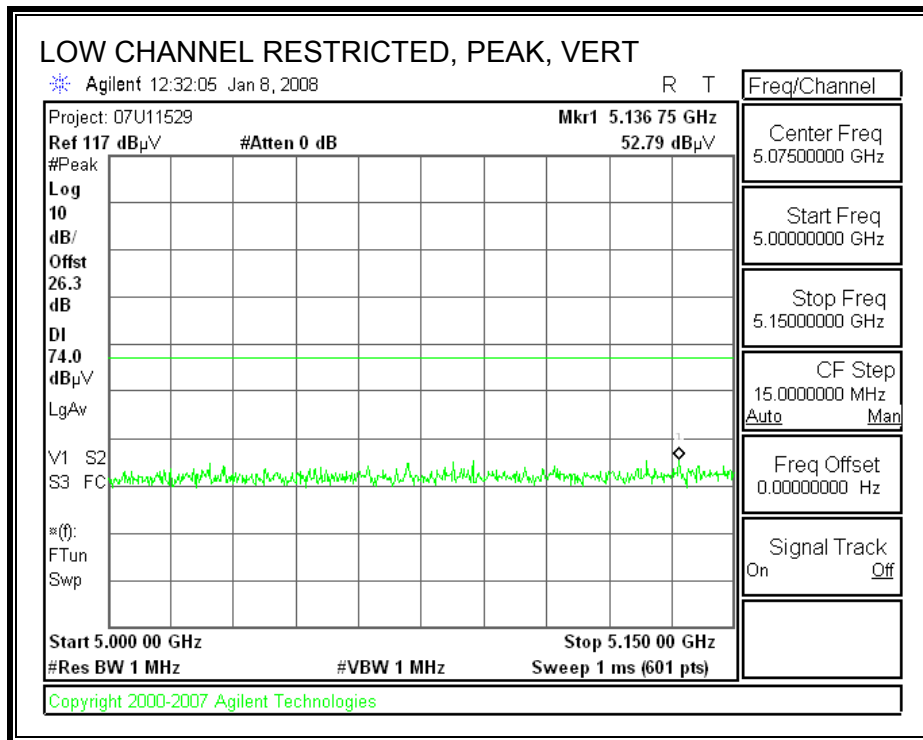

AUTHORIZED BANDEDGE (HIGH CHANNEL)

The EUT passes Conducted Spurious test; therefore this test is not performed.

HARMONICS AND SPURIOUS EMISSIONS

High Frequency Measurement
 Compliance Certification Services

Company: Broadcom
 Project #: 07U11529
 Date: 01/09/08
 Test Engineer: Vien Tran
 Configuration: EUT with 5.6dBi Antenna
 Mode: Tx 5.2 GHz Band_5150-5250 MHz_11n 20MHz CDD

Test Equipment:

Horn 1-18GHz	Pre-amplifier 1-26GHz	Pre-amplifier 26-40GHz	Horn > 18GHz	Limit
T60; S/N: 2238 @3m	T34 HP 8449B			FCC 15.205

Hi Frequency Cables

2 foot cable	3 foot cable	12 foot cable	HPF	Reject Filter	
	Vien 187215002	Ninous 208946002	HPF_7.6GHz		Peak Measurements RBW=VBW=1MHz Average Measurements RBW=1MHz ; VBW=10Hz

f GHz	Dist (m)	Read Pk dBuV	Read Avg dBuV	AF dB/m	CL dB	Amp dB	D Corr dB	Filtr dB	Peak dBuV/m	Avg dBuV/m	Pk Lim dBuV/m	Avg Lim dBuV/m	Pk Mar dB	Avg Mar dB	Notes (V/H)
LOW CHANNEL, 5180 MHz															
15.540	3.0	50.3	39.6	38.0	5.1	-32.2	0.0	0.7	61.9	51.2	74	54	-12.1	-2.8	H
15.540	3.0	49.7	38.8	38.0	5.1	-32.2	0.0	0.7	61.3	50.4	74	54	-12.7	-3.6	V
MID CHANNEL, 5200 MHz															
15.600	3.0	51.1	40.8	38.0	5.1	-32.2	0.0	0.7	62.7	52.4	74	54	-11.3	-1.6	H
15.600	3.0	49.6	39.3	38.0	5.1	-32.2	0.0	0.7	61.2	50.9	74	54	-12.8	-3.1	V
HI CHANNEL, 5240 MHz															
15.720	3.0	51.4	41.2	37.9	5.1	-32.2	0.0	0.7	63.0	52.8	74	54	-11.0	-1.2	V
15.720	3.0	50.0	39.6	37.9	5.1	-32.2	0.0	0.7	61.6	51.2	74	54	-12.4	-2.8	V

No other emissions were detected above system noise floor

f	Measurement Frequency	Amp	Preamp Gain	Avg Lim	Average Field Strength Limit
Dist	Distance to Antenna	D Corr	Distance Correct to 3 meters	Pk Lim	Peak Field Strength Limit
Read	Analyzer Reading	Avg	Average Field Strength @ 3 m	Avg Mar	Margin vs. Average Limit
AF	Antenna Factor	Peak	Calculated Peak Field Strength	Pk Mar	Margin vs. Peak Limit
CL	Cable Loss	HPF	High Pass Filter		

10.2.3. 802.11n HT40 MODE

RESTRICTED BANDEDGE (LOW CHANNEL, HORIZONTAL)

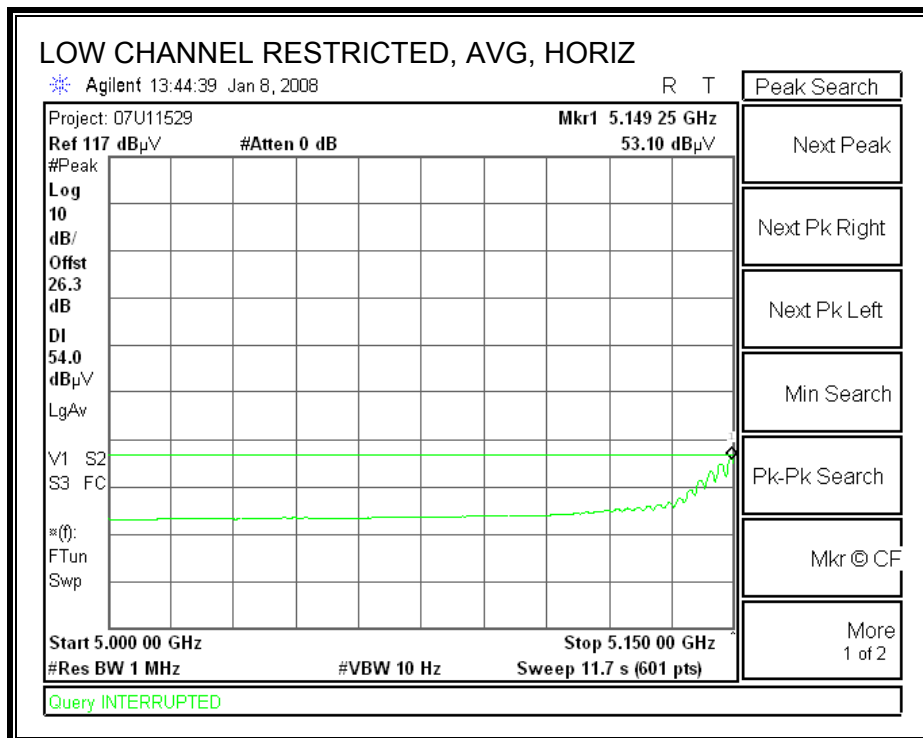
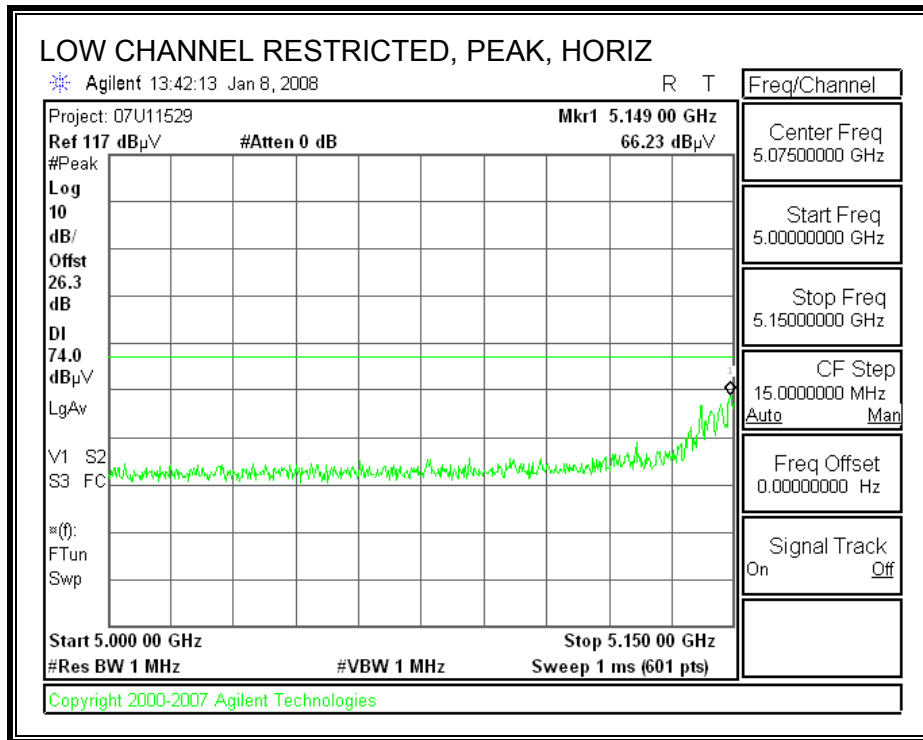

RESTRICTED BANDEDGE (LOW CHANNEL, VERTICAL)

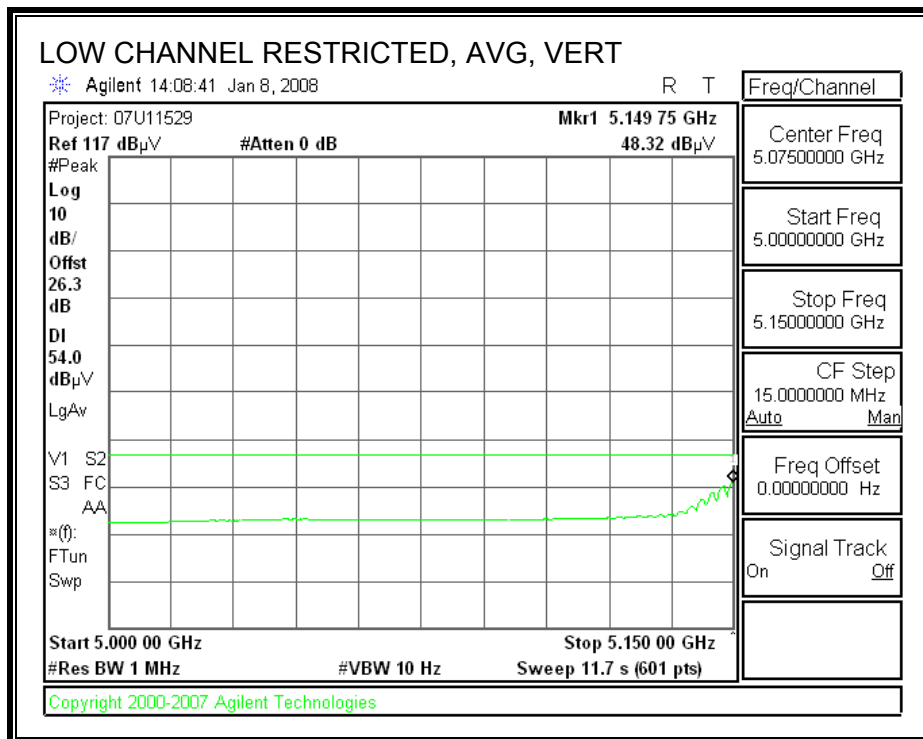
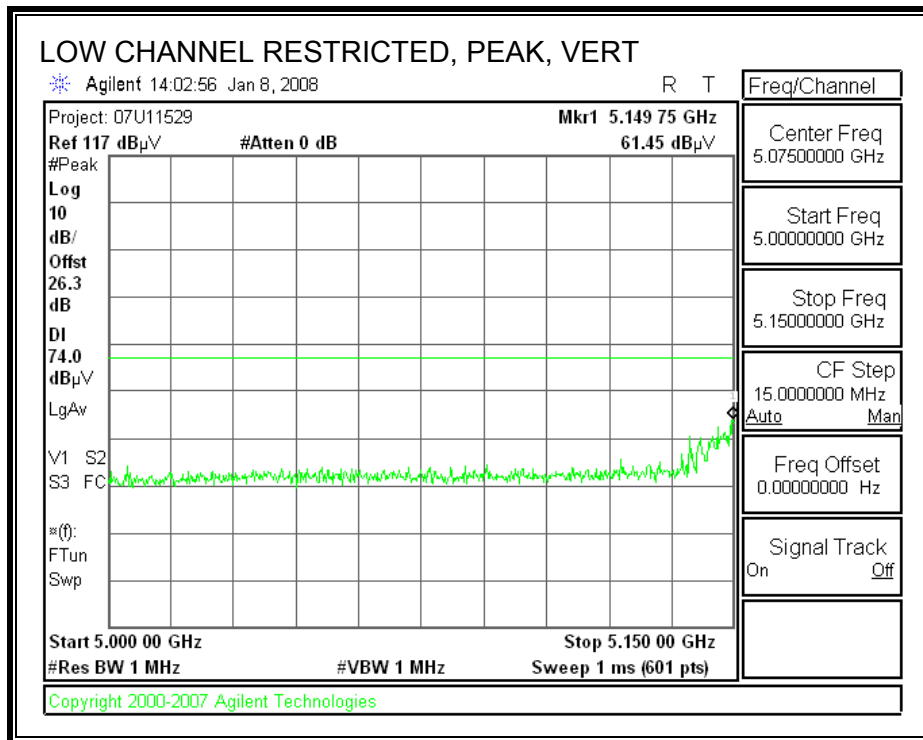

AUTHORIZED BANDEDGE (HIGH CHANNEL)

The EUT passes Conducted Spurious test; therefore this test is not performed.

HARMONICS AND SPURIOUS EMISSIONS

High Frequency Measurement
 Compliance Certification Services, Fremont 3m Chamber

Company: Broadcom
 Project #: 07U11529
 Date: 01/09/08
 Test Engineer: Vien Tran
 Configuration: EUT with 5.6dBi Antenna
 Mode: Tx 5.2 GHz Band_5150-5250MHz_11n 40MHz CDD

Test Equipment:

Horn 1-18GHz	Pre-amplifier 1-26GHz	Pre-amplifier 26-40GHz	Horn > 18GHz	Limit
T60; S/N: 2238 @3m	T34 HP 8449B			FCC 15.205

Hi Frequency Cables

2 foot cable	3 foot cable	12 foot cable	HPF	Reject Filter	
	Vien 187215002	Ninous 208946002	HPF_7.6GHz		Peak Measurements RBW=VBW=1MHz Average Measurements RBW=1MHz ; VBW=10Hz

f GHz	Dist (m)	Read Pk dBuV	Read Avg dBuV	AF dB/m	CL dB	Amp dB	D Corr dB	Filtr dB	Peak dBuV/m	Avg dBuV/m	Pk Lim dBuV/m	Avg Lim dBuV/m	Pk Mar dB	Avg Mar dB	Notes (V/H)
LOW CHANNEL, 5190 MHz															
15.570	3.0	50.7	39.9	38.0	5.1	-32.2	0.0	0.7	62.3	51.5	74	54	-11.7	-2.5	H
15.570	3.0	47.5	37.8	38.0	5.1	-32.2	0.0	0.7	59.1	49.4	74	54	-14.9	-4.6	V
MID CHANNEL, 5230 MHz															
15.960	3.0	51.1	40.3	37.8	5.2	-32.1	0.0	0.7	62.7	52.0	74	54	-11.3	-2.0	H
15.960	3.0	48.4	38.7	37.8	5.2	-32.1	0.0	0.7	60.0	50.3	74	54	-14.0	-3.7	V

No other emissions were detected above system noise floor

f	Measurement Frequency	Amp	Preamp Gain	Avg Lim	Average Field Strength Limit
Dist	Distance to Antenna	D Corr	Distance Correct to 3 meters	Pk Lim	Peak Field Strength Limit
Read	Analyzer Reading	Avg	Average Field Strength @ 3 m	Avg Mar	Margin vs. Average Limit
AF	Antenna Factor	Peak	Calculated Peak Field Strength	Pk Mar	Margin vs. Peak Limit
CL	Cable Loss	HPF	High Pass Filter		

10.3. TRANSMITTER ABOVE 1 GHZ FOR THE BAND 5.25–5.35 GHZ

10.3.1. 802.11a MODE

AUTHORIZED BANDEDGE (LOW CHANNEL)

The EUT passes Conducted Spurious test; therefore this test is not performed.

RESTRICTED BANDEDGE (HIGH CHANNEL, HORIZONTAL)

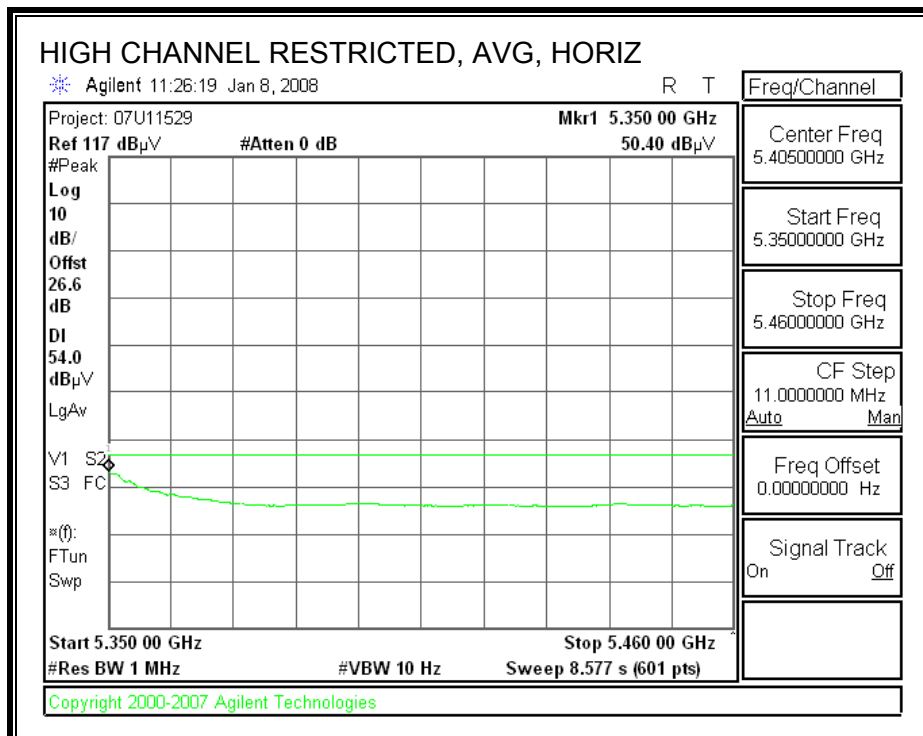
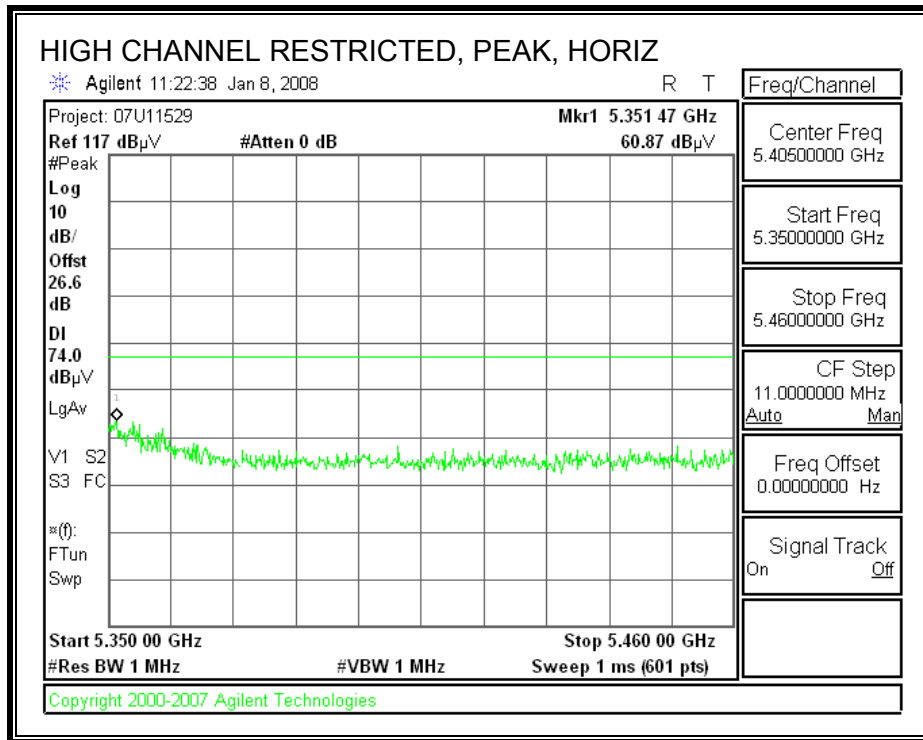

RESTRICTED BANDEDGE (HIGH CHANNEL, VERTICAL)

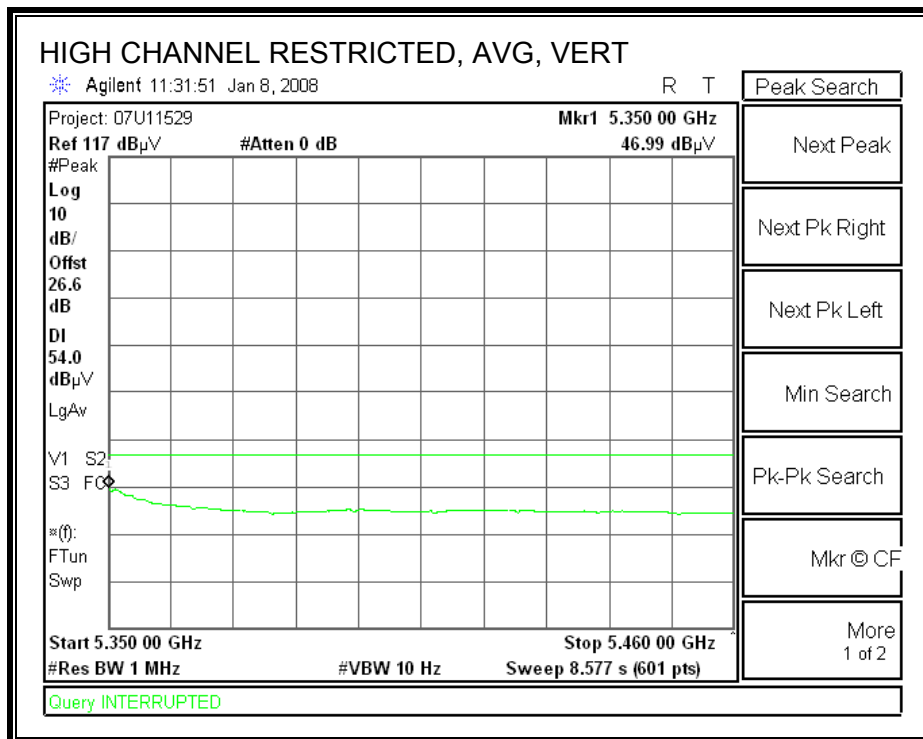
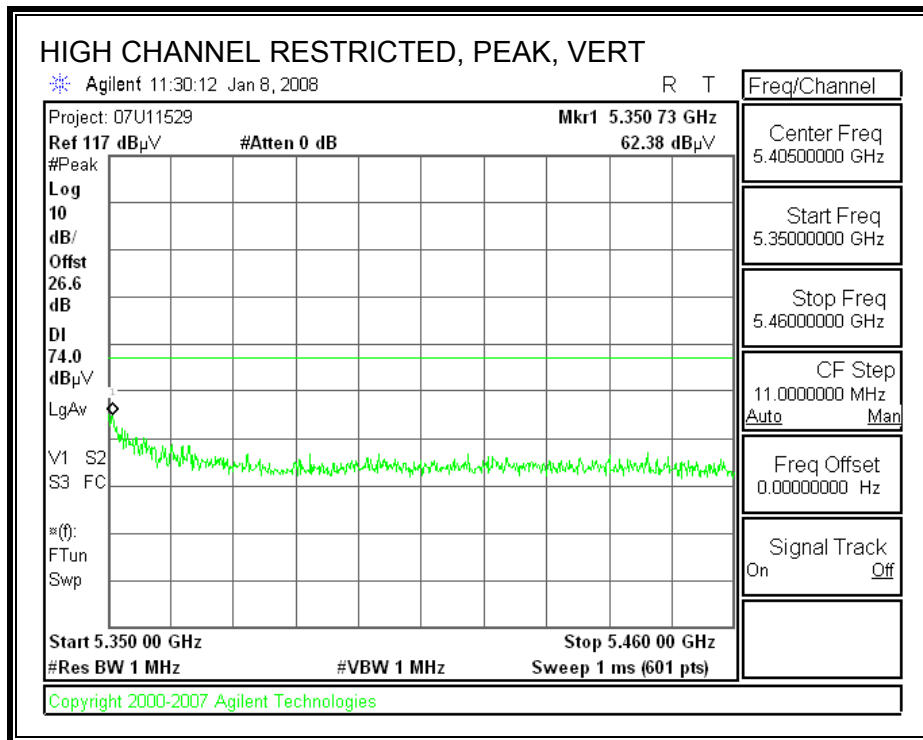

HARMONICS AND SPURIOUS EMISSIONS

High Frequency Measurement Compliance Certification Services, Fremont 3m Chamber																
Company: Broadcom Project #: 07U11529 Date: 01/09/2008 Test Engineer: Vien Tran Configuration: EUT with 5.6dBi Antenna Mode: Tx 5.2 GHz Band_5250-5350 MHz_11a Legacy																
Test Equipment:																
Horn 1-18GHz			Pre-amplifier 1-26GHz			Pre-amplifier 26-40GHz			Horn > 18GHz			Limit				
T60; S/N: 2238 @3m			T34 HP 8449B									FCC 15.205				
Hi Frequency Cables																
2 foot cable			3 foot cable			12 foot cable			HPF		Reject Filter		Peak Measurements RBW=VBW=1MHz Average Measurements RBW=1MHz ; VBW=10Hz			
			Vien 187215002			Ninous 208946002			HPF_7.6GHz							
f GHz	Dist (m)	Read Pk dBuV	Read Avg dBuV	AF dB/m	CL dB	Amp dB	D Corr dB	Filtr dB	Peak dBuV/m	Avg dBuV/m	Pk Lim dBuV/m	Avg Lim dBuV/m	Pk Mar dB	Avg Mar dB	Notes (V/H)	
LOW CHANNEL, 5260 MHz																
15.780	3.0	50.4	40.2	37.9	5.1	-32.2	0.0	0.7	62.0	51.8	74	54	-12.0	-2.2	H	
15.780	3.0	49.6	39.0	37.9	5.1	-32.2	0.0	0.7	61.2	50.6	74	54	-12.8	-3.4	V	
MID CHANNEL, 5300 MHz																
10.600	3.0	46.3	33.8	37.4	3.9	-32.6	0.0	0.8	55.8	43.3	74	54	-18.2	-10.7	H	
15.900	3.0	51.1	41.3	37.9	5.2	-32.1	0.0	0.7	62.7	52.9	74	54	-11.3	-1.1	H	
10.600	3.0	43.4	32.2	37.4	3.9	-32.6	0.0	0.8	52.9	41.7	74	54	-21.1	-12.3	V	
15.900	3.0	48.5	39.5	37.9	5.2	-32.1	0.0	0.7	60.1	51.1	74	54	-13.9	-2.9	V	
HI CHANNEL, 5320 MHz																
10.640	3.0	44.5	32.5	37.3	3.9	-32.6	0.0	0.8	54.0	42.0	74	54	-20.0	-12.0	H	
15.960	3.0	50.4	41.1	37.8	5.2	-32.1	0.0	0.7	62.0	52.7	74	54	-12.0	-1.3	H	
10.640	3.0	43.3	31.6	37.3	3.9	-32.6	0.0	0.8	52.8	41.1	74	54	-21.2	-12.9	V	
15.960	3.0	49.3	39.4	37.8	5.2	-32.1	0.0	0.7	60.9	51.0	74	54	-13.1	-3.0	V	
No other emissions were detected above system noise floor																
f	Measurement Frequency					Amp	Preamp Gain					Avg Lim	Average Field Strength Limit			
Dist	Distance to Antenna					D Corr	Distance Correct to 3 meters					Pk Lim	Peak Field Strength Limit			
Read	Analyzer Reading					Avg	Average Field Strength @ 3 m					Avg Mar	Margin vs. Average Limit			
AF	Antenna Factor					Peak	Calculated Peak Field Strength					Pk Mar	Margin vs. Peak Limit			
CL	Cable Loss					HPF	High Pass Filter									

10.3.2. 802.11n HT20 MODE

AUTHORIZED BANDEDGE (LOW CHANNEL)

The EUT passes Conducted Spurious test; therefore this test is not performed.

RESTRICTED BANDEDGE (HIGH CHANNEL, HORIZONTAL)

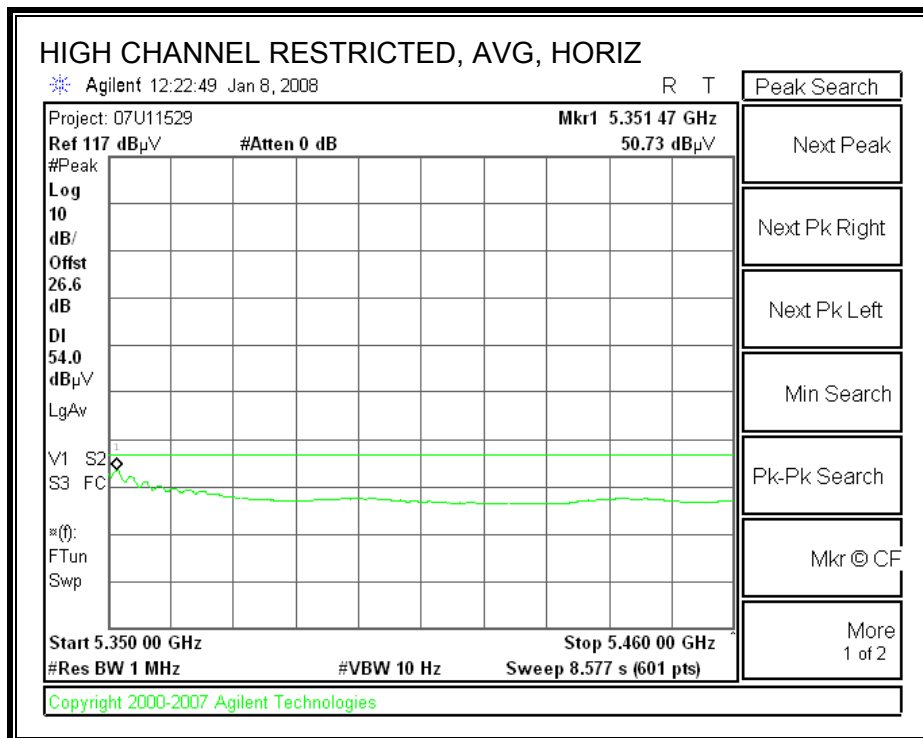
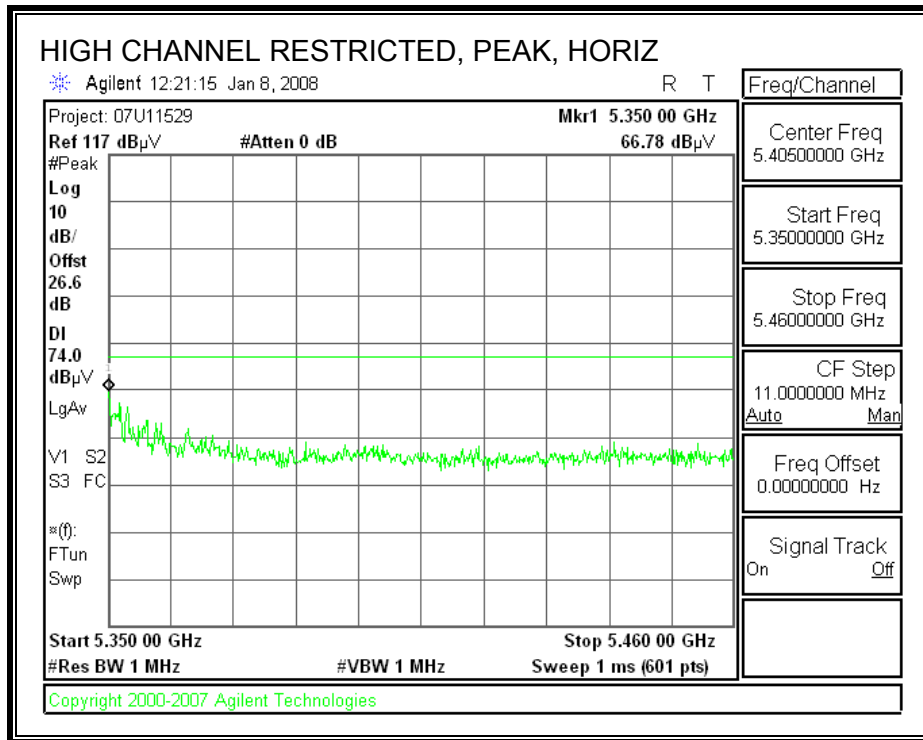

RESTRICTED BANDEDGE (HIGH CHANNEL, VERTICAL)

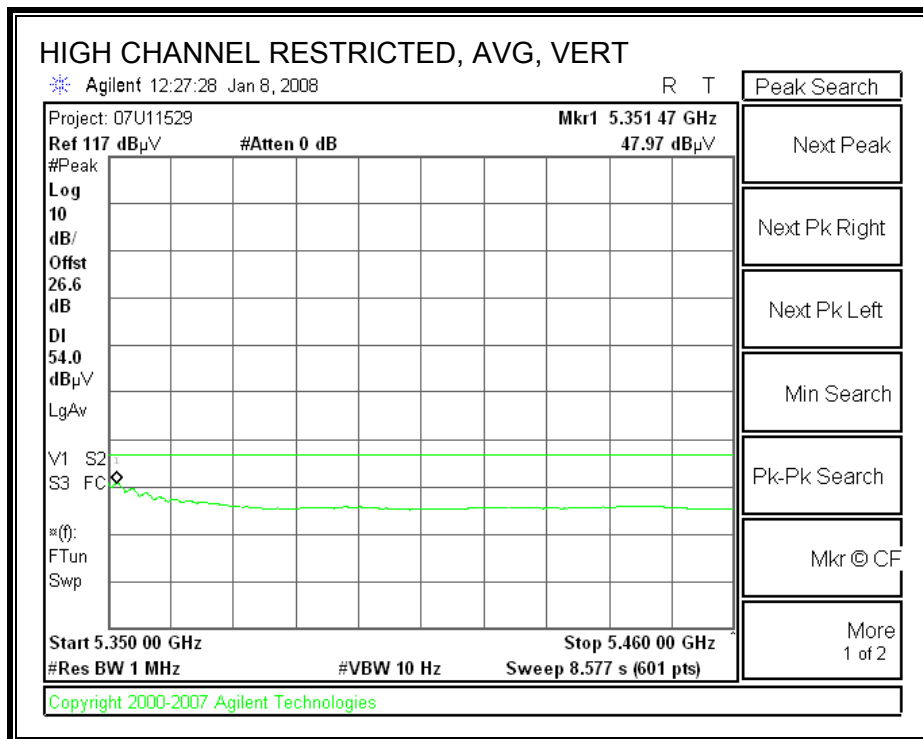
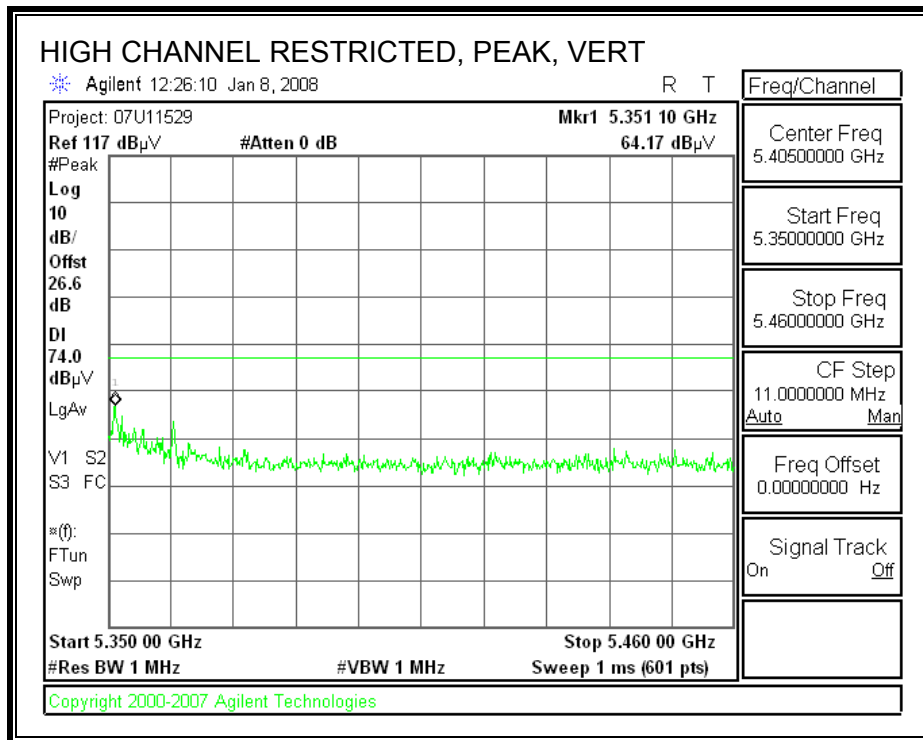

HARMONICS AND SPURIOUS EMISSIONS

High Frequency Measurement Compliance Certification Services, Fremont 3m Chamber																
Company: Broadcom Project #: 07U11529 Date: 01/09/08 Test Engineer: Vien Tran Configuration: EUT with 5.6dBi Antenna Mode: Tx 5.2 GHz Band_5250-5350 MHz_11n 20MHz CDD																
Test Equipment:																
Horn 1-18GHz			Pre-amplifier 1-26GHz			Pre-amplifier 26-40GHz			Horn > 18GHz			Limit				
T60; S/N: 2238 @3m			T34 HP 8449B									FCC 15.205				
Hi Frequency Cables																
2 foot cable			3 foot cable			12 foot cable			HPF		Reject Filter					
			Vien 187215002			Ninous 208946002			HPF_7.6GHz				Peak Measurements RBW=VBW=1MHz Average Measurements RBW=1MHz ; VBW=10Hz			
f GHz	Dist (m)	Read Pk dBuV	Read Avg dBuV	AF dB/m	CL dB	Amp dB	D Corr dB	Filtr dB	Peak dBuV/m	Avg dBuV/m	Pk Lim dBuV/m	Avg Lim dBuV/m	Pk Mar dB	Avg Mar dB	Notes (V/H)	
LOW CHANNEL, 5260 MHz																
15.780	3.0	51.4	39.9	37.9	5.1	-32.2	0.0	0.7	63.0	51.5	74	54	-11.0	-2.5	H	
15.780	3.0	49.6	38.9	37.9	5.1	-32.2	0.0	0.7	61.2	50.5	74	54	-12.8	-3.5	V	
MID CHANNEL, 5300 MHz																
10.600	3.0	46.5	33.7	37.4	3.9	-32.6	0.0	0.8	56.0	43.2	74	54	-18.0	-10.8	H	
15.780	3.0	51.5	40.9	37.9	5.1	-32.2	0.0	0.7	63.1	52.5	74	54	-10.9	-1.5	H	
10.600	3.0	43.1	32.1	37.4	3.9	-32.6	0.0	0.8	52.6	41.6	74	54	-21.4	-12.4	V	
15.780	3.0	48.5	39.5	37.9	5.1	-32.2	0.0	0.7	60.1	51.1	74	54	-13.9	-2.9	V	
HI CHANNEL, 5320 MHz																
10.640	3.0	44.3	33.0	37.3	3.9	-32.6	0.0	0.8	53.8	42.5	74	54	-20.2	-11.5	H	
15.960	3.0	50.9	40.4	37.8	5.2	-32.1	0.0	0.7	62.5	52.0	74	54	-11.5	-2.0	H	
10.640	3.0	43.9	32.3	37.3	3.9	-32.6	0.0	0.8	53.4	41.8	74	54	-20.6	-12.2	V	
15.960	3.0	49.4	38.8	37.8	5.2	-32.1	0.0	0.7	61.0	50.4	74	54	-13.0	-3.6	V	
No other emissions were detected above system noise floor																
f	Measurement Frequency					Amp	Preamp Gain					Avg Lim	Average Field Strength Limit			
Dist	Distance to Antenna					D Corr	Distance Correct to 3 meters					Pk Lim	Peak Field Strength Limit			
Read	Analyzer Reading					Avg	Average Field Strength @ 3 m					Avg Mar	Margin vs. Average Limit			
AF	Antenna Factor					Peak	Calculated Peak Field Strength					Pk Mar	Margin vs. Peak Limit			
CL	Cable Loss					HPF	High Pass Filter									

10.3.3. 802.11n HT40 MODE

AUTHORIZED BANDEDGE (LOW CHANNEL)

The EUT passes Conducted Spurious test; therefore this test is not performed.

RESTRICTED BANDEDGE (HIGH CHANNEL, HORIZONTAL)

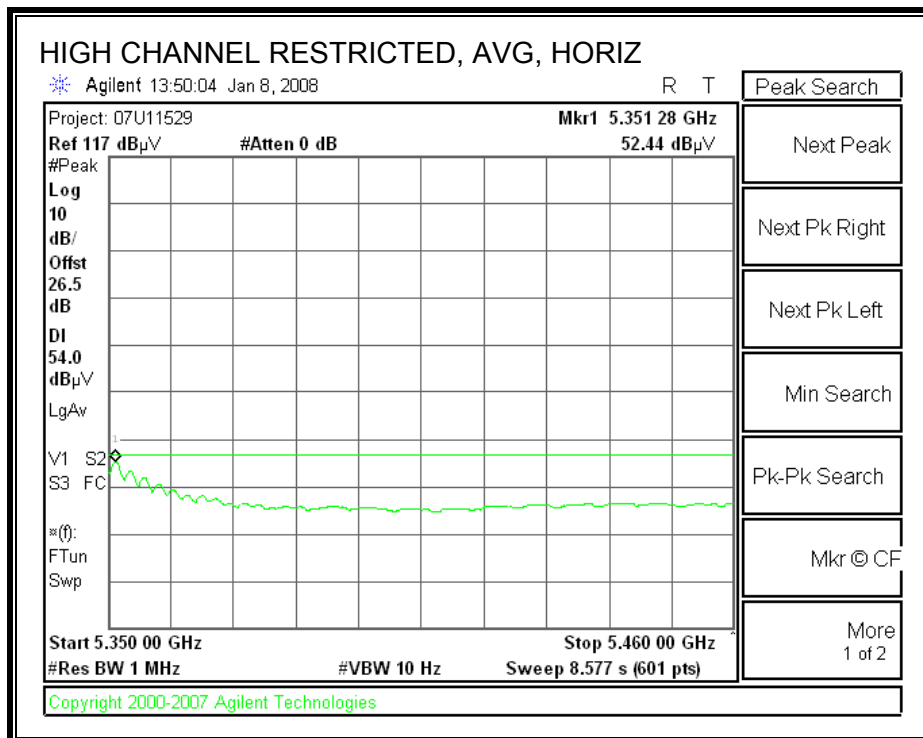
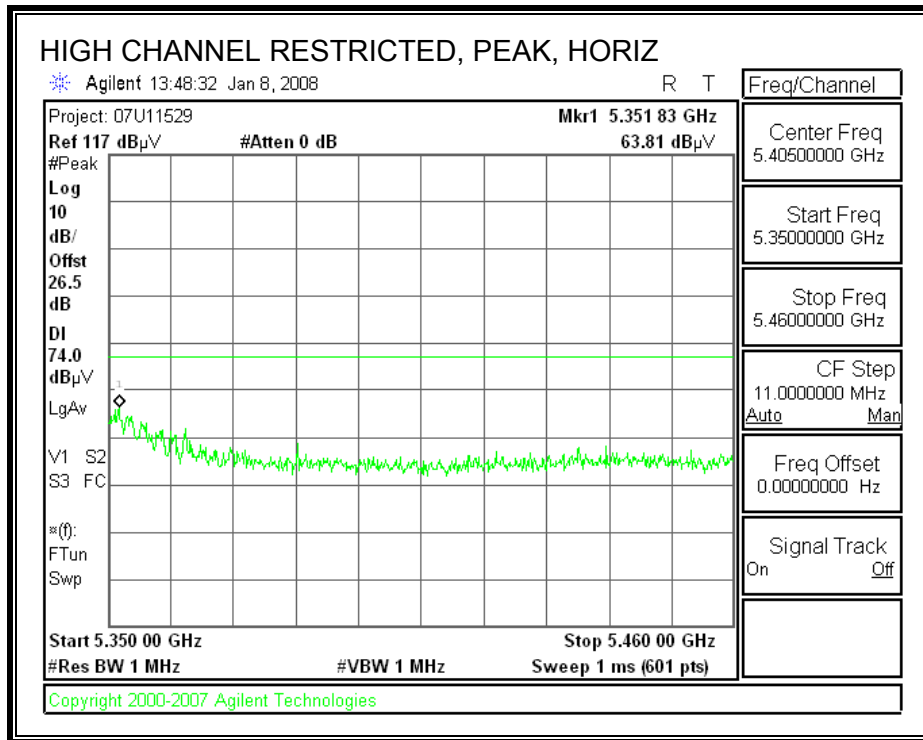

RESTRICTED BANDEDGE (HIGH CHANNEL, VERTICAL)

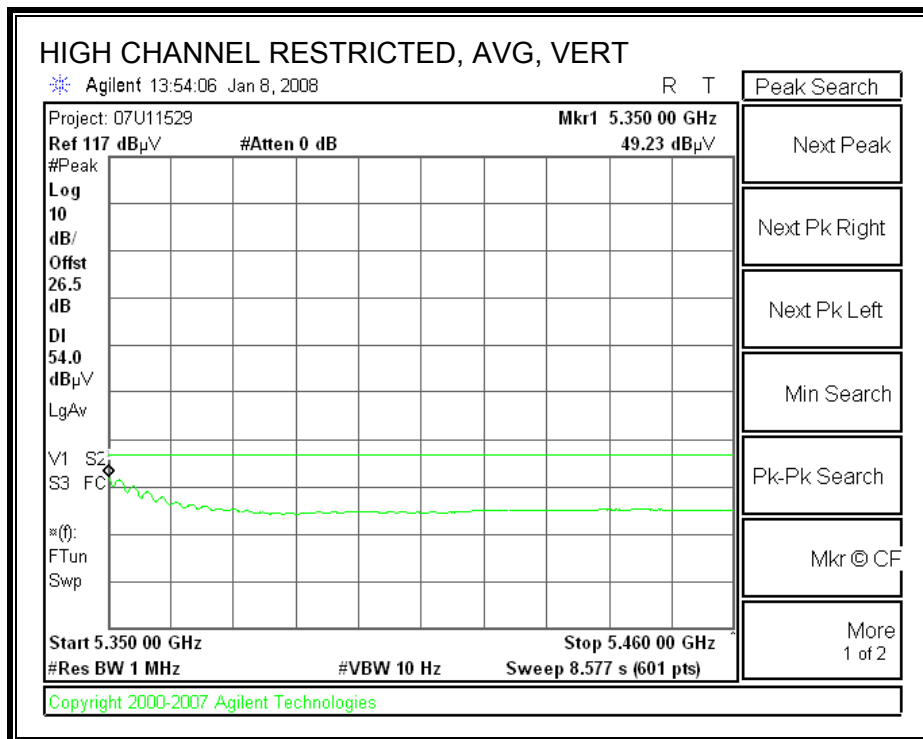
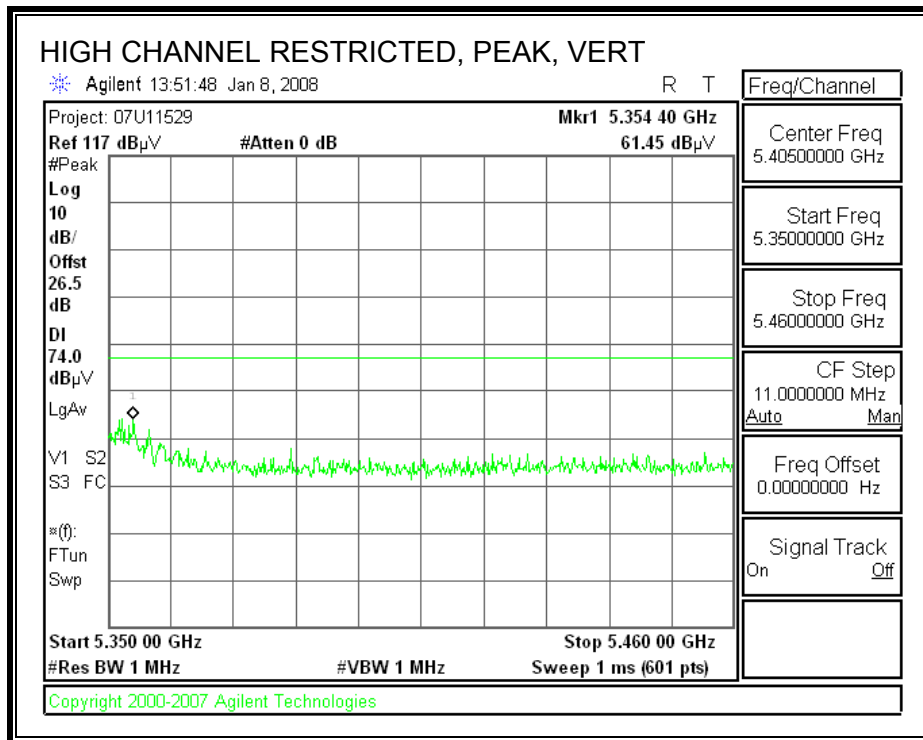

HARMONICS AND SPURIOUS EMISSIONS

High Frequency Measurement
 Compliance Certification Services, Fremont 3m Chamber

Company: Broadcom
 Project #: 07U11529
 Date: 01/09/08
 Test Engineer: Vien Tran
 Configuration: EUT with 5.6dBi Antenna
 Mode: Tx 5.2 GHz Band_5250-5350MHz_1In 40MHz CDD

Test Equipment:

Horn 1-18GHz T60; S/N: 2238 @3m	Pre-amplifier 1-26GHz T34 HP 8449B	Pre-amplifier 26-40GHz	Horn > 18GHz	Limit FCC 15.205
------------------------------------	---------------------------------------	------------------------	--------------	---------------------

Hi Frequency Cables

2 foot cable	3 foot cable Vien 187215002	12 foot cable Ninous 208946002	HPF HPF_7.6GHz	Reject Filter	Peak Measurements RBW=VBW=1MHz Average Measurements RBW=1MHz ; VBW=10Hz
--------------	--------------------------------	-----------------------------------	-------------------	---------------	--

f GHz	Dist (m)	Read Pk dBuV	Read Avg dBuV	AF dB/m	CL dB	Amp dB	D Corr dB	Fltr dB	Peak dBuV/m	Avg dBuV/m	Pk Lim dBuV/m	Avg Lim dBuV/m	Pk Mar dB	Avg Mar dB	Notes (V/H)
LOW CHANNEL, 5270 MHz															
15.810	3.0	51.6	40.9	37.9	5.2	-32.2	0.0	0.7	63.2	52.5	74	54	-10.8	-1.5	H
15.810	3.0	50.7	40.0	37.9	5.2	-32.2	0.0	0.7	62.3	51.6	74	54	-11.7	-2.4	V
HI CHANNEL, 5310 MHz															
10.620	3.0	47.3	37.3	37.4	3.9	-32.6	0.0	0.8	56.8	46.8	74	54	-17.2	-7.2	H
15.930	3.0	50.8	40.4	37.8	5.2	-32.1	0.0	0.7	62.4	52.0	74	54	-11.6	-2.0	H
10.620	3.0	46.8	36.6	37.4	3.9	-32.6	0.0	0.8	56.3	46.1	74	54	-17.7	-7.9	V
15.930	3.0	49.6	38.7	37.8	5.2	-32.1	0.0	0.7	61.2	50.3	74	54	-12.8	-3.7	V

No other emissions were detected above system noise floor

f	Measurement Frequency	Amp	Preamp Gain	Avg Lim	Average Field Strength Limit
Dist	Distance to Antenna	D Corr	Distance Correct to 3 meters	Pk Lim	Peak Field Strength Limit
Read	Analyzer Reading	Avg	Average Field Strength @ 3 m	Avg Mar	Margin vs. Average Limit
AF	Antenna Factor	Peak	Calculated Peak Field Strength	Pk Mar	Margin vs. Peak Limit
CL	Cable Loss	HPF	High Pass Filter		

10.4. TRANSMITTER ABOVE 1 GHZ FOR 5.47–5.725 GHZ BAND

10.4.1. 802.11a MODE

RESTRICTED BANDEDGE (LOW CHANNEL, HORIZONTAL)

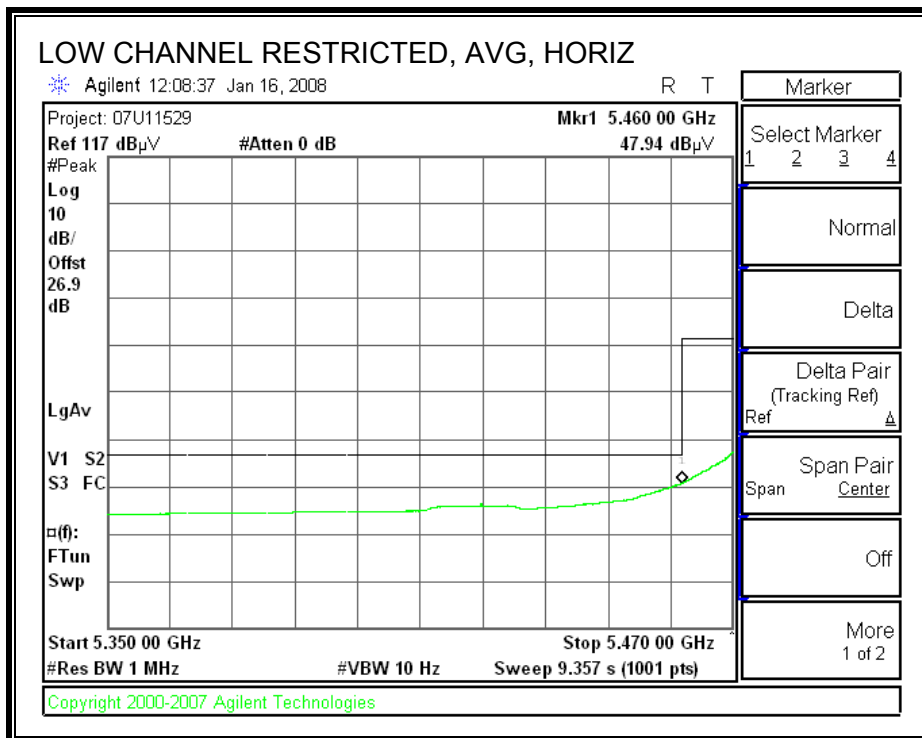
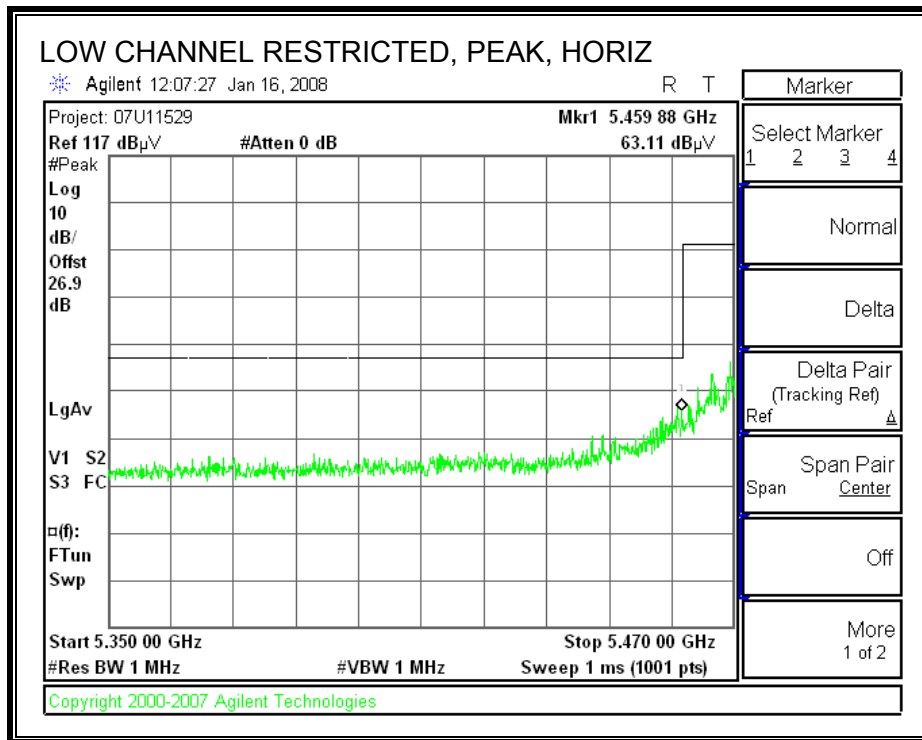

RESTRICTED BANDEDGE (LOW CHANNEL, VERTICAL)

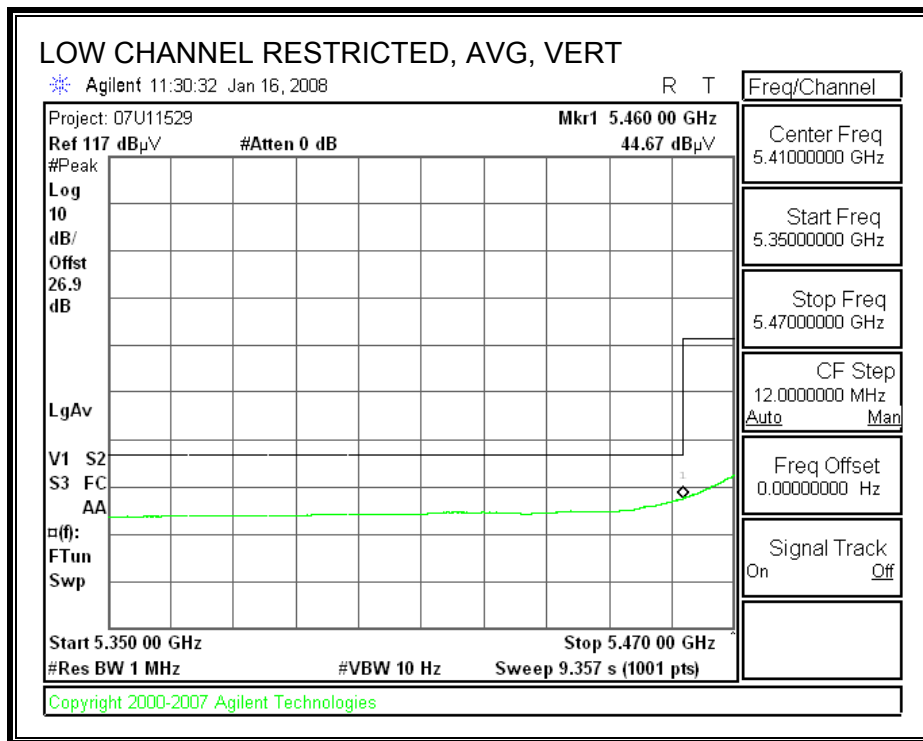
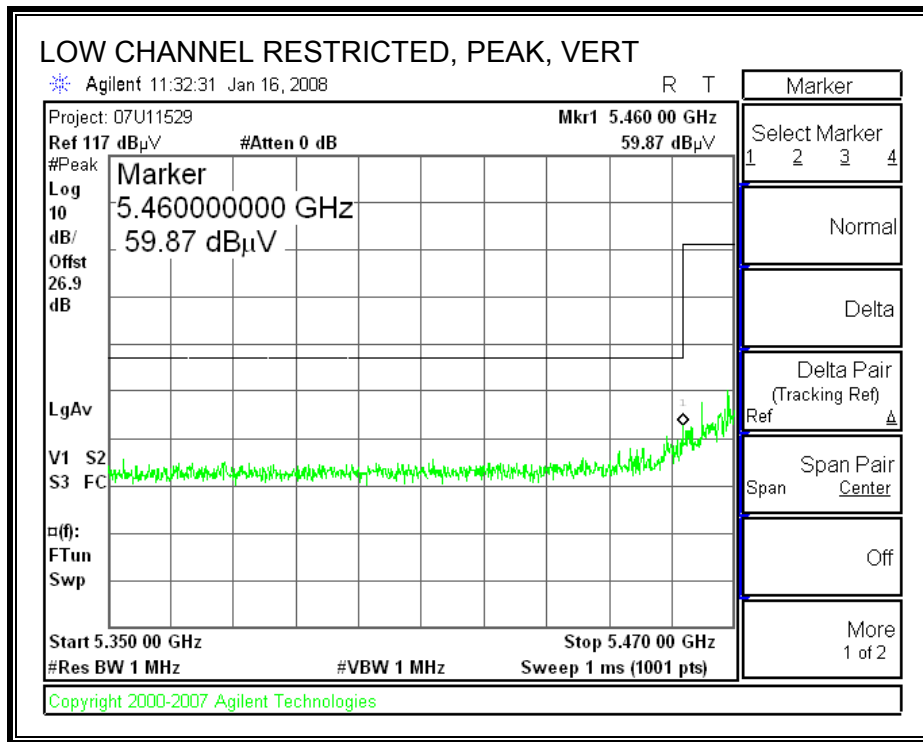

AUTHORIZED BANDEDGE (HIGH CHANNEL, HORIZONTAL)

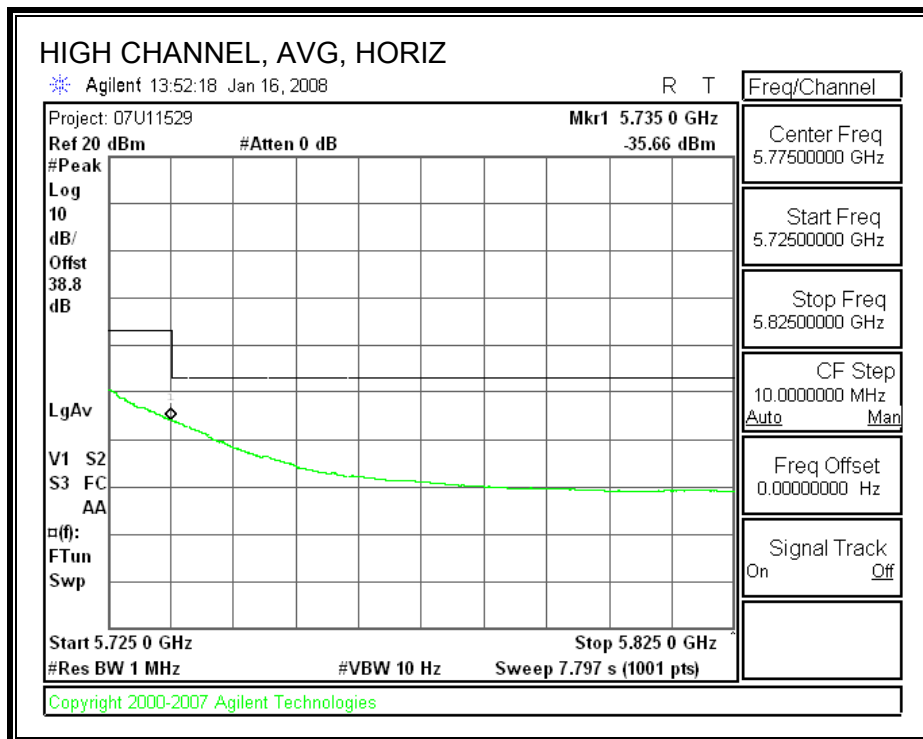
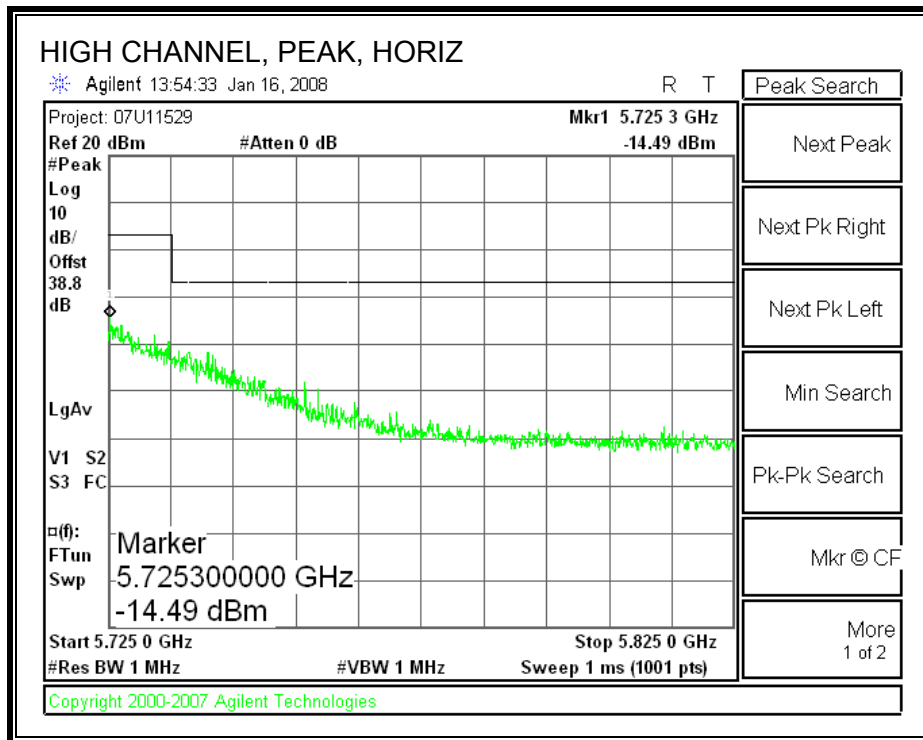

AUTHORIZED BANDEDGE (HIGH CHANNEL, VERTICAL)

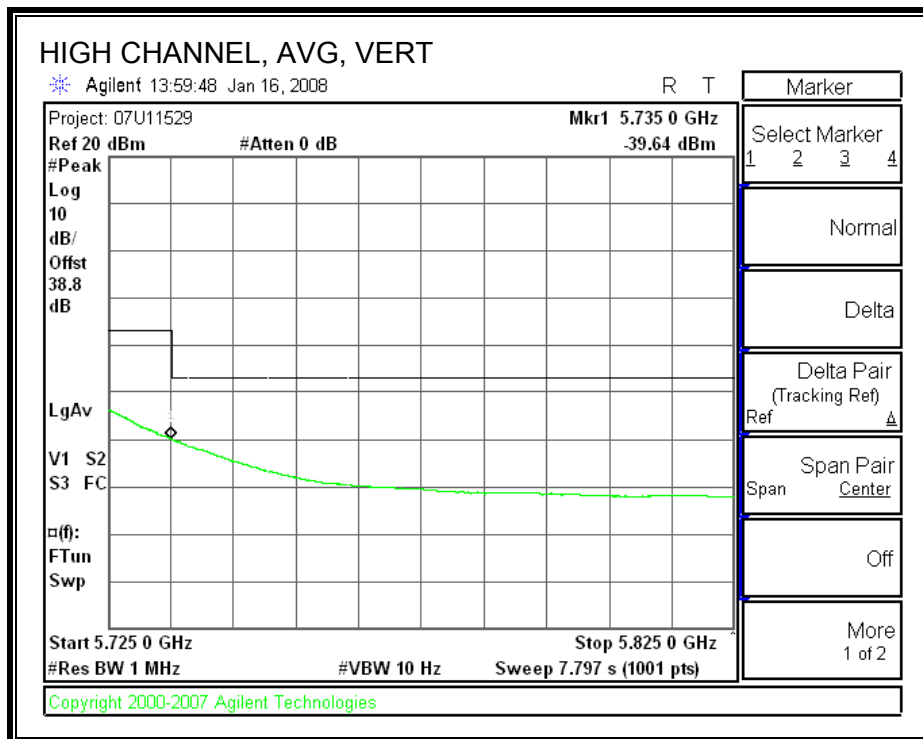
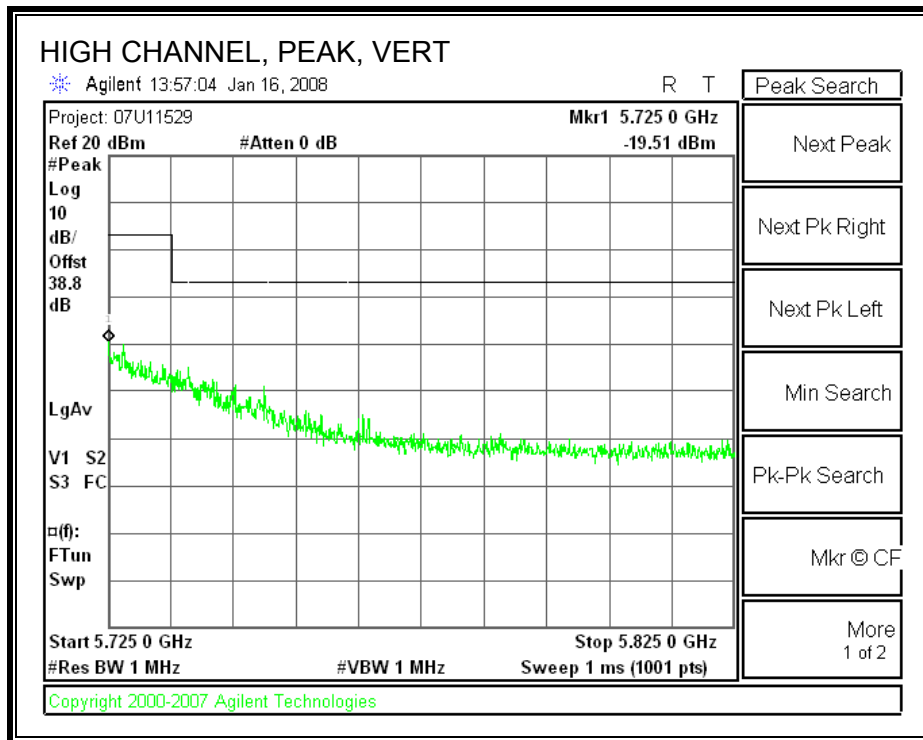

HARMONICS AND SPURIOUS EMISSIONS

High Frequency Measurement
 Compliance Certification Services, Fremont 3m Chamber

Company: Broadcom
 Project #: 07U11529
 Date: 01/16/2008
 Test Engineer: Vien Tran
 Configuration: EUT with 4.2dBi Antenna
 Mode: Tx 5.6 GHz Band_11a Legacy

Test Equipment:

Horn 1-18GHz T60; S/N: 2238 @3m	Pre-amplifier 1-26GHz T34 HP 8449B	Pre-amplifier 26-40GHz	Horn > 18GHz	Limit FCC 15.205
------------------------------------	---------------------------------------	------------------------	--------------	---------------------

Hi Frequency Cables

2 foot cable	3 foot cable Vien 187215002	12 foot cable Ninous 208946002	HPF HPF_7.6GHz	Reject Filter	Peak Measurements RBW=VBW=1MHz Average Measurements RBW=1MHz ; VBW=10Hz
--------------	--------------------------------	-----------------------------------	-------------------	---------------	--

f GHz	Dist (m)	Read Pk dBuV	Read Avg. dBuV	AF dB/m	CL dB	Amp dB	D Corr dB	Filtr dB	Peak dBuV/m	Avg dBuV/m	Pk Lim dBuV/m	Avg Lim dBuV/m	Pk Mar dB	Avg Mar dB	Notes (V/H)
LOW CHANNEL, 5500 MHz															
11.000	3.0	56.6	44.3	37.3	3.9	-32.6	0.0	0.7	66.0	53.7	74	54	-8.0	-0.3	H
11.000	3.0	55.2	43.4	37.3	3.9	-32.6	0.0	0.7	64.6	52.8	74	54	-9.4	-1.2	V
MID CHANNEL, 5600 MHz															
11.200	3.0	55.9	43.6	37.3	3.9	-32.6	0.0	0.7	65.4	53.1	74	54	-8.6	-0.9	H
11.200	3.0	54.4	42.6	37.3	3.9	-32.6	0.0	0.7	63.9	52.1	74	54	-10.1	-1.9	V
HI CHANNEL, 5700 MHz															
11.400	3.0	51.9	40.6	37.4	3.9	-32.5	0.0	0.7	61.4	50.1	74	54	-12.6	-3.9	H
11.400	3.0	53.8	42.5	37.4	3.9	-32.5	0.0	0.7	63.3	52.0	74	54	-10.7	-2.0	V

No other emissions were detected above system noise floor

f	Measurement Frequency	Amp	Preamp Gain	Avg Lim	Average Field Strength Limit
Dist	Distance to Antenna	D Corr	Distance Correct to 3 meters	Pk Lim	Peak Field Strength Limit
Read	Analyzer Reading	Avg	Average Field Strength @ 3 m	Avg Mar	Margin vs. Average Limit
AF	Antenna Factor	Peak	Calculated Peak Field Strength	Pk Mar	Margin vs. Peak Limit
CL	Cable Loss	HPF	High Pass Filter		

10.4.2. 802.11n HT20 MODE
RESTRICTED BANDEDGE (LOW CHANNEL, HORIZONTAL)

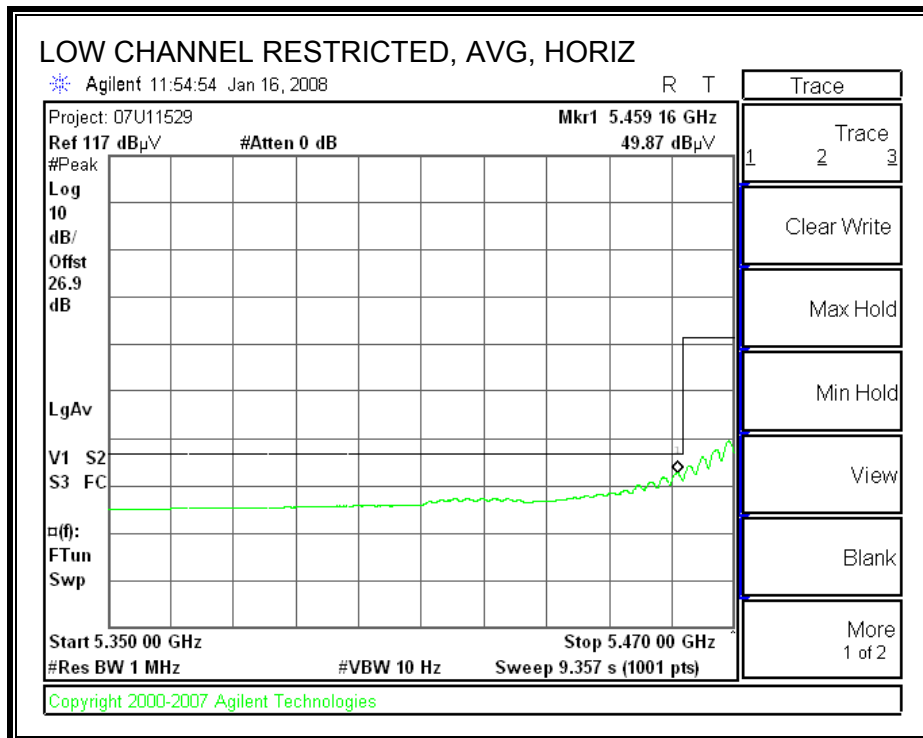
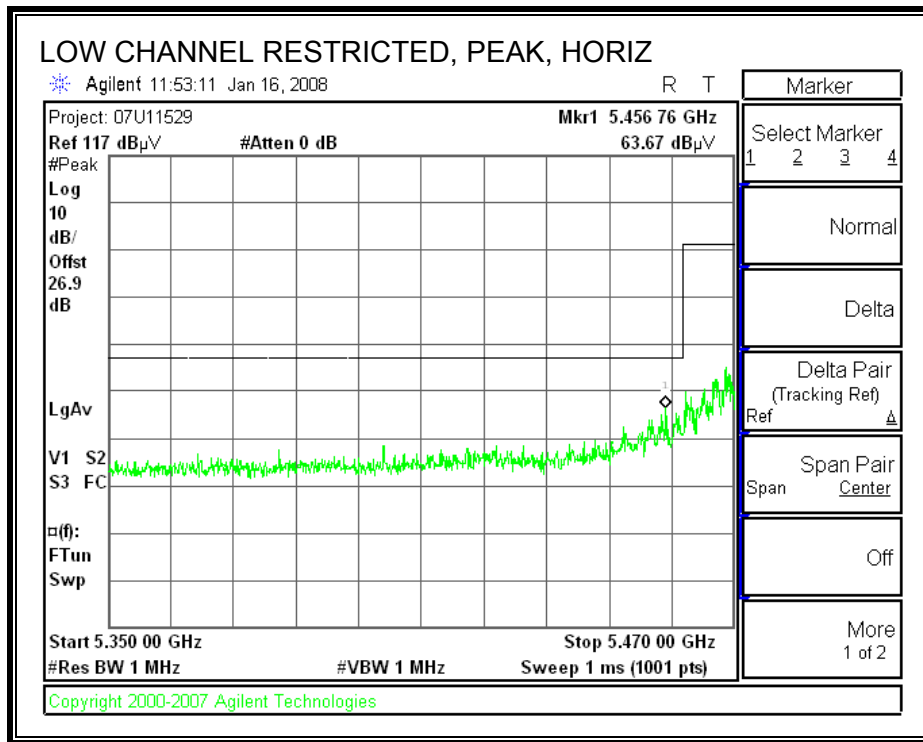

RESTRICTED BANDEDGE (LOW CHANNEL, VERTICAL)

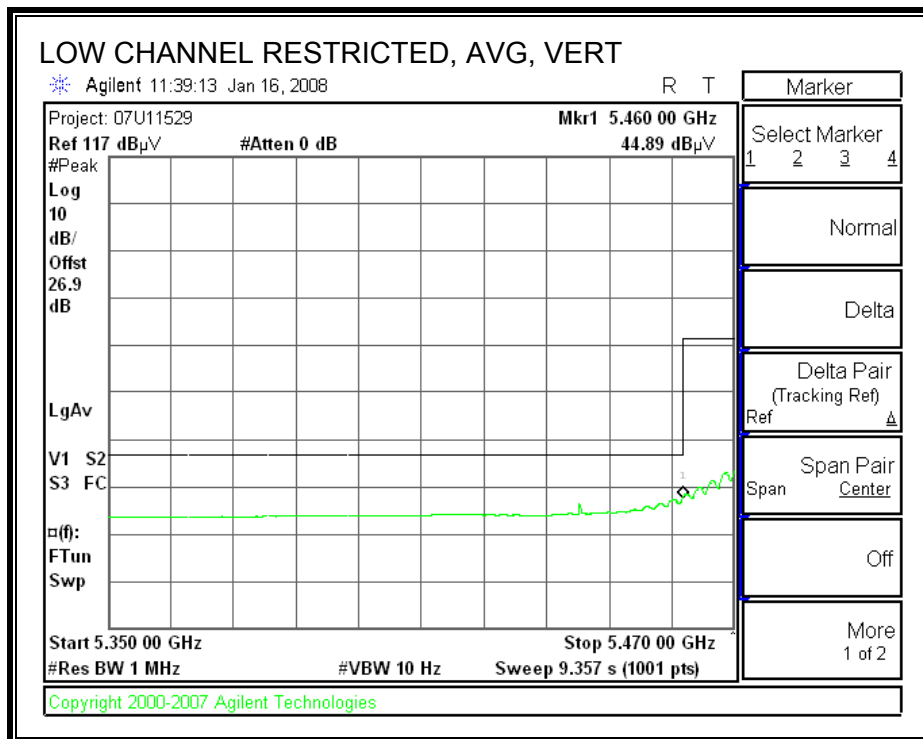
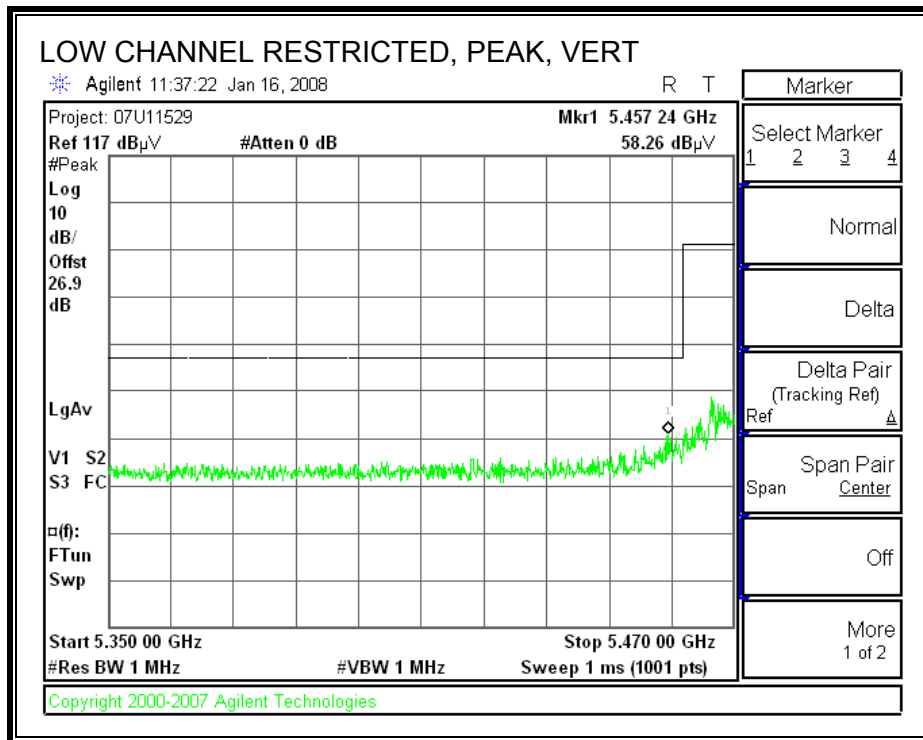

AUTHORIZED BANDEDGE (HIGH CHANNEL, HORIZONTAL)

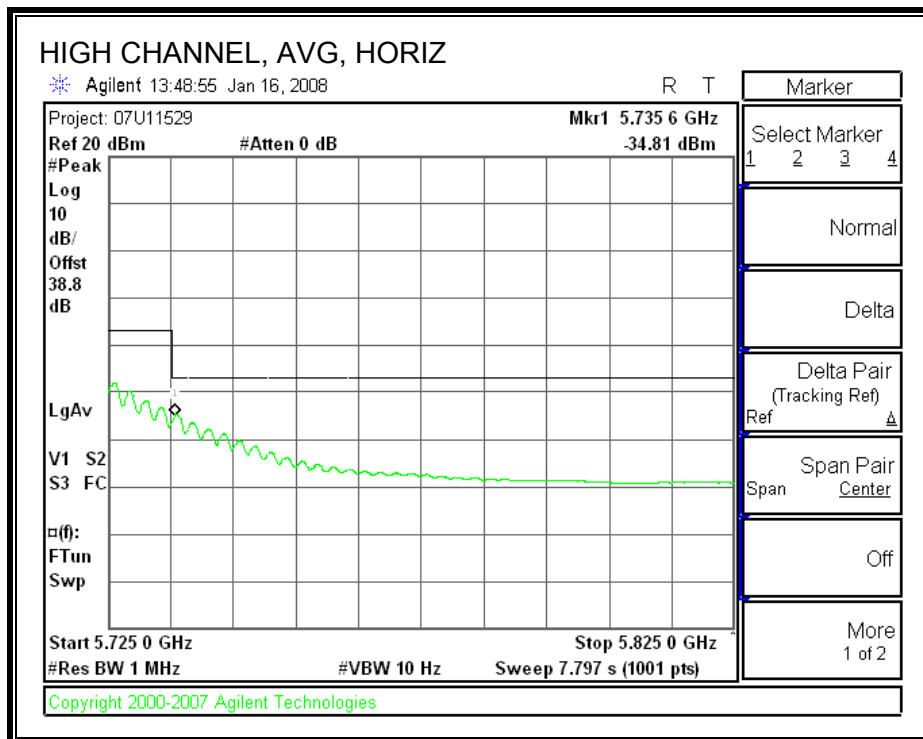
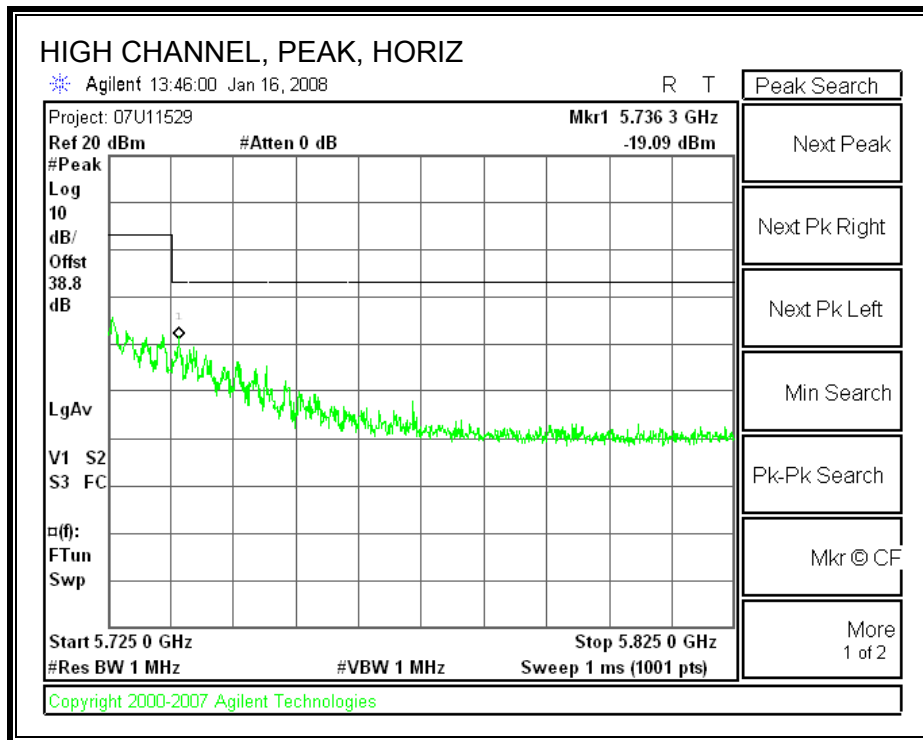

AUTHORIZED BANDEDGE (HIGH CHANNEL, VERTICAL)

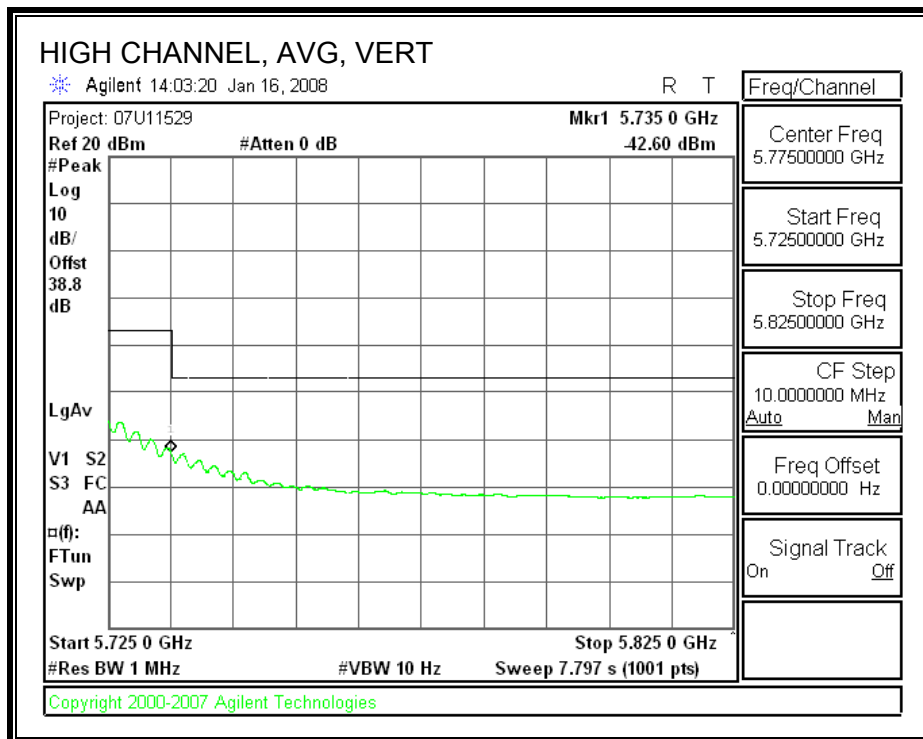
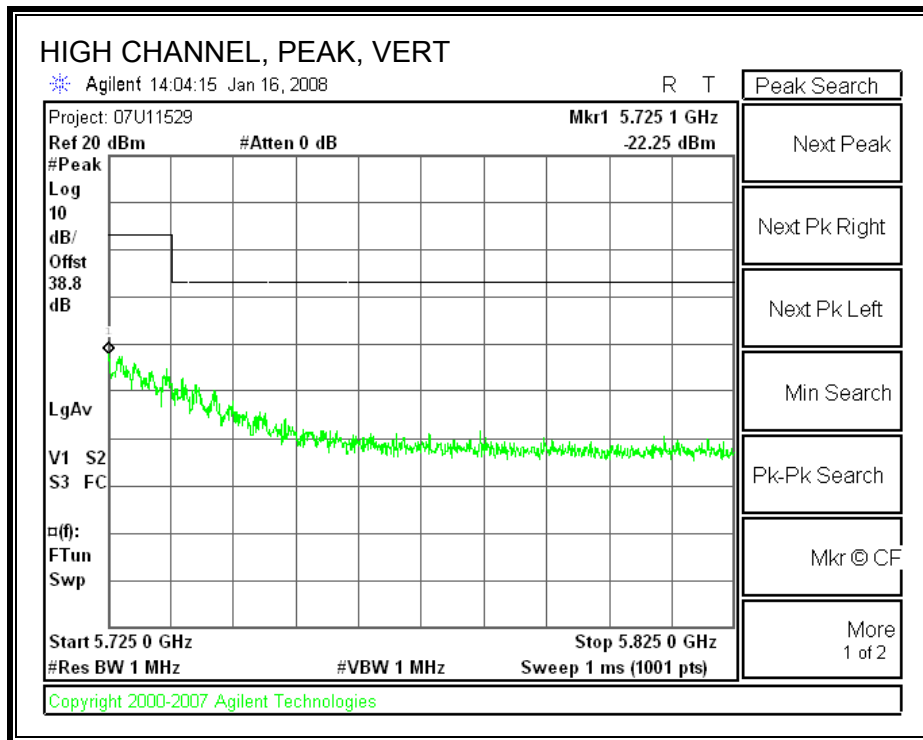

HARMONICS AND SPURIOUS EMISSIONS

High Frequency Measurement
 Compliance Certification Services, Fremont 3m Chamber

Company: Broadcom
 Project #: 07U11529
 Date: 01/16/2008
 Test Engineer: Vien Tran
 Configuration: EUT with 4.2dBi Antenna
 Mode: Tx 5.6 GHz Band_1In 20 MHz

Test Equipment:

Horn 1-18GHz T60; S/N: 2238 @3m	Pre-amplifier 1-26GHz T34 HP 8449B	Pre-amplifier 26-40GHz	Horn > 18GHz	Limit FCC 15.205
------------------------------------	---------------------------------------	------------------------	--------------	---------------------

Hi Frequency Cables

2 foot cable	3 foot cable Vien 187215002	12 foot cable Ninous 208946002	HPF HPF_7.6GHz	Reject Filter	Peak Measurements RBW=VBW=1MHz Average Measurements RBW=1MHz ; VBW=10Hz
--------------	--------------------------------	-----------------------------------	-------------------	---------------	--

f GHz	Dist (m)	Read Pk dBuV	Read Avg dBuV	AF dB/m	CL dB	Amp dB	D Corr dB	Filtr dB	Peak dBuV/m	Avg dBuV/m	Pk Lim dBuV/m	Avg Lim dBuV/m	Pk Mar dB	Avg Mar dB	Notes (V/H)
LOW CHANNEL, 5500 MHz															
11.000	3.0	51.7	39.6	37.3	3.9	-32.6	0.0	0.7	61.1	49.0	74	54	-12.9	-5.0	H
11.000	3.0	53.8	41.7	37.3	3.9	-32.6	0.0	0.7	63.2	51.1	74	54	-10.8	-2.9	V
MID CHANNEL, 5600 MHz															
11.200	3.0	50.4	38.6	37.3	3.9	-32.6	0.0	0.7	59.9	48.1	74	54	-14.1	-5.9	H
11.200	3.0	51.3	39.9	37.3	3.9	-32.6	0.0	0.7	60.8	49.4	74	54	-13.2	-4.6	V
HI CHANNEL, 5700 MHz															
11.400	3.0	48.3	37.9	37.4	3.9	-32.5	0.0	0.7	57.8	47.4	74	54	-16.2	-6.6	H
11.400	3.0	51.2	39.7	37.4	3.9	-32.5	0.0	0.7	60.7	49.2	74	54	-13.3	-4.8	V

No other emissions were detected above system noise floor

f	Measurement Frequency	Amp	Preamp Gain	Avg Lim	Average Field Strength Limit
Dist	Distance to Antenna	D Corr	Distance Correct to 3 meters	Pk Lim	Peak Field Strength Limit
Read	Analyzer Reading	Avg	Average Field Strength @ 3 m	Avg Mar	Margin vs. Average Limit
AF	Antenna Factor	Peak	Calculated Peak Field Strength	Pk Mar	Margin vs. Peak Limit
CL	Cable Loss	HPF	High Pass Filter		

10.4.3. 802.11n HT40 MODE
RESTRICTED BANDEDGE (LOW CHANNEL, HORIZONTAL)

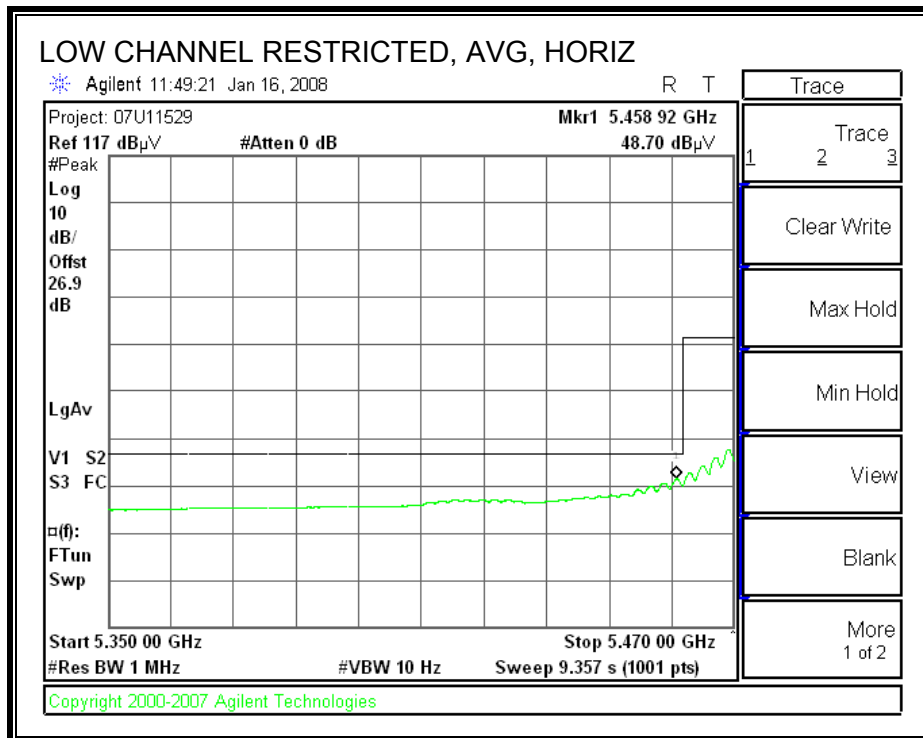
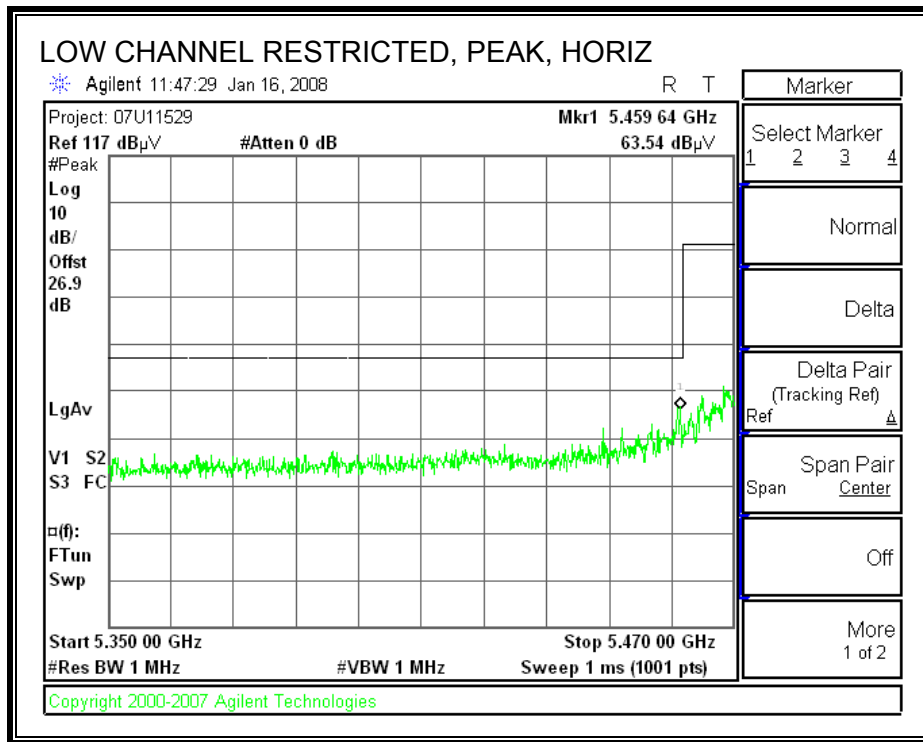

RESTRICTED BANDEDGE (LOW CHANNEL, VERTICAL)

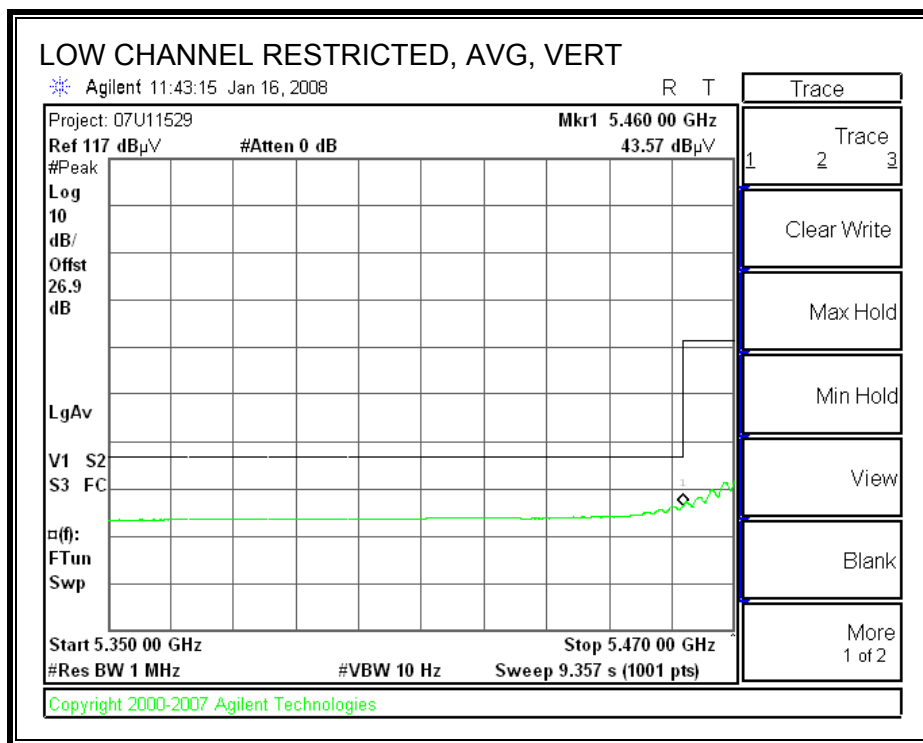
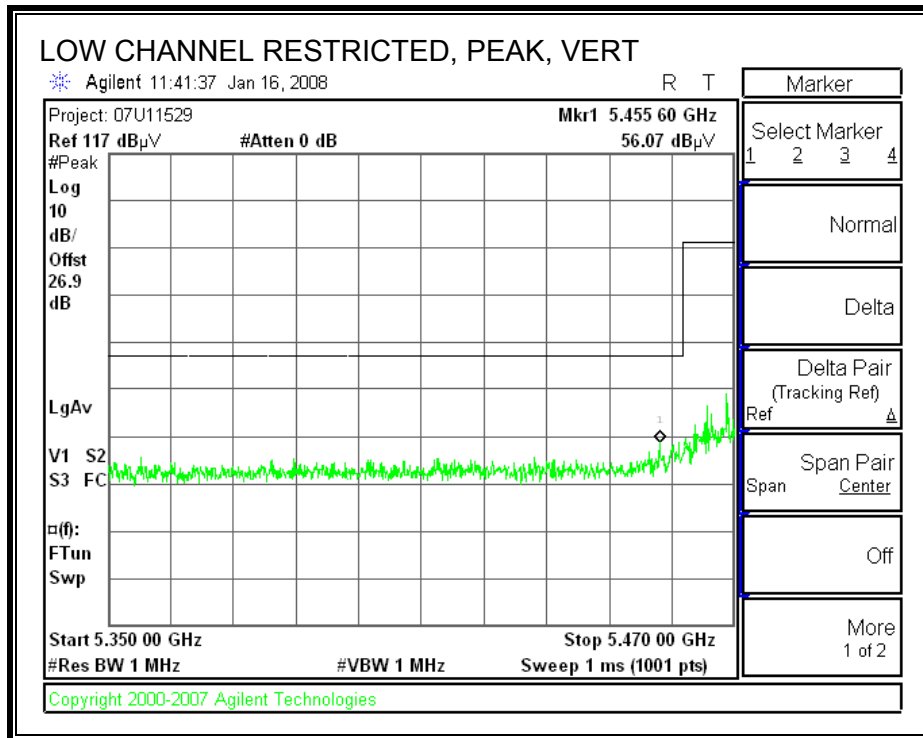

AUTHORIZED BANDEDGE (HIGH CHANNEL, HORIZONTAL)

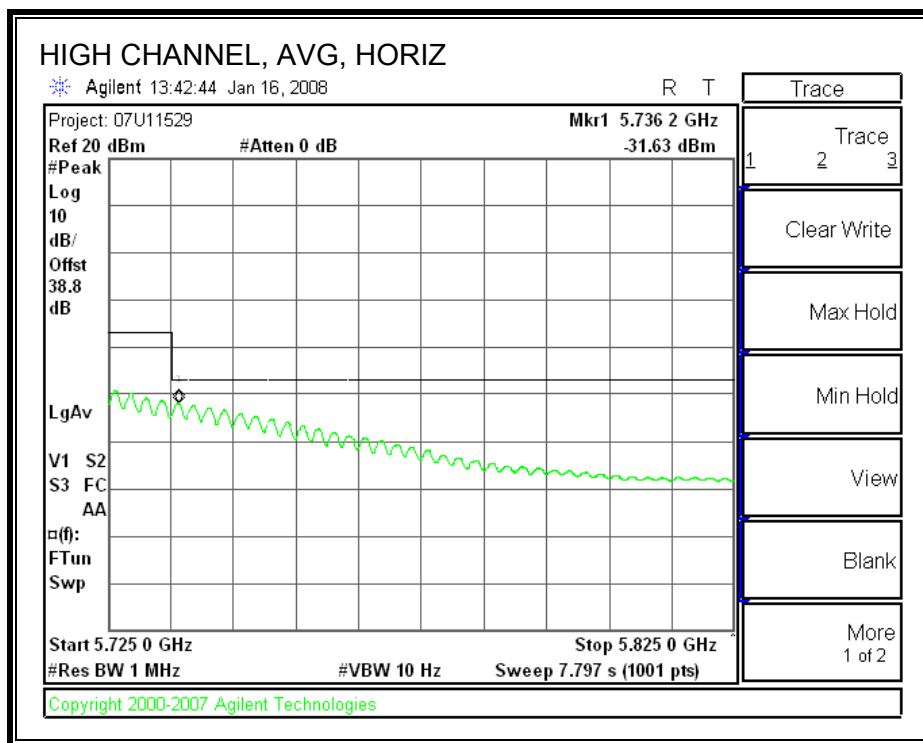
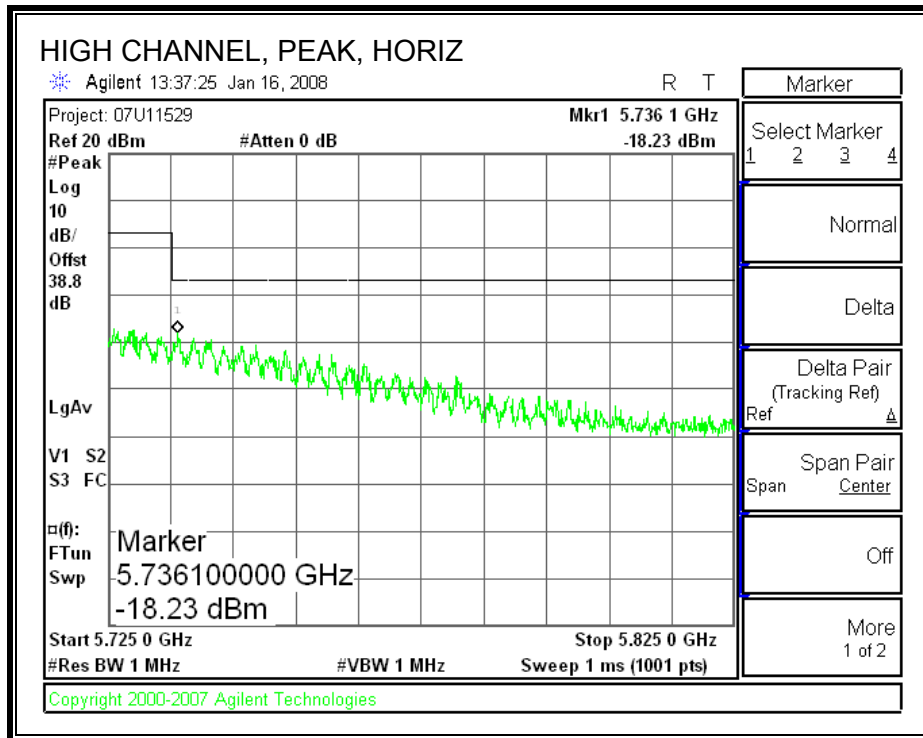

AUTHORIZED BANDEDGE (HIGH CHANNEL, VERTICAL)

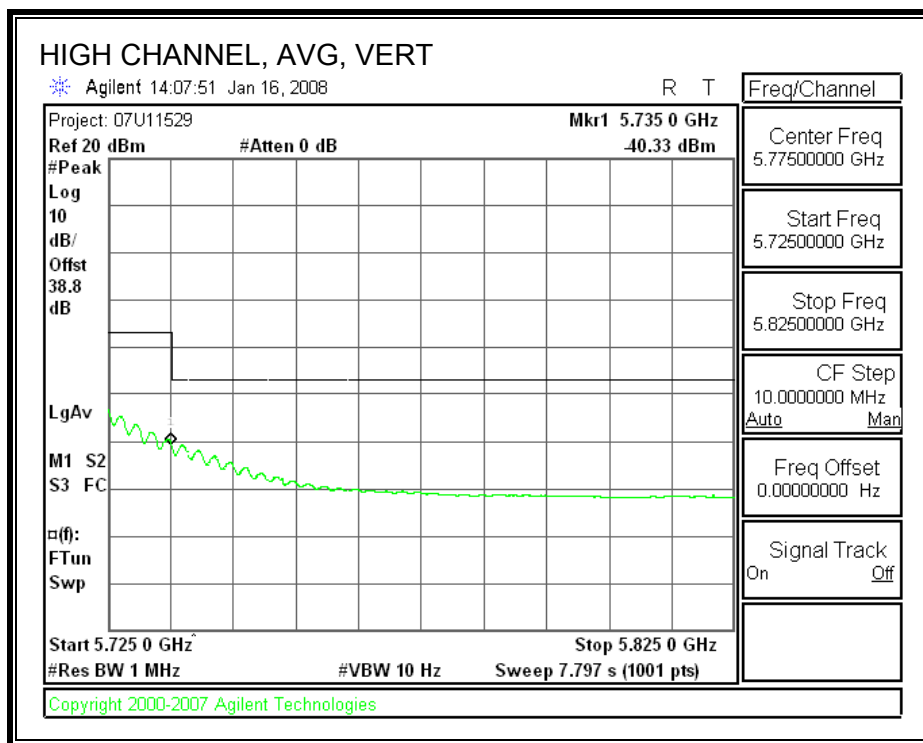
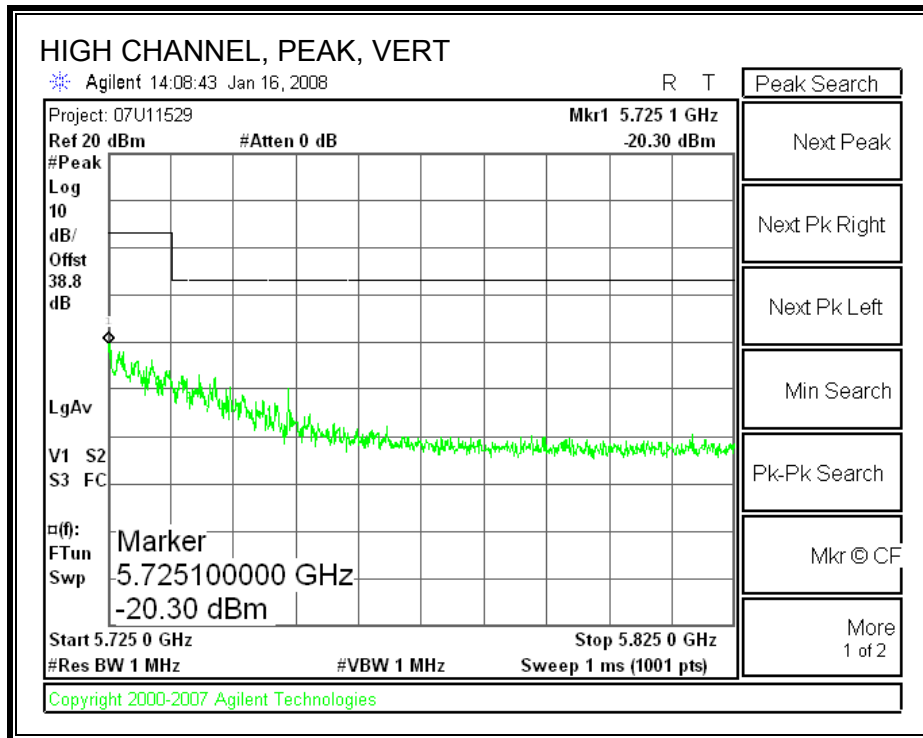

HARMONICS AND SPURIOUS EMISSIONS

High Frequency Measurement
 Compliance Certification Services, Fremont 3m Chamber

Company: Broadcom
 Project #: 07U11529
 Date: 01/16/2008
 Test Engineer: Vien Tran
 Configuration: EUT with 4.2dBi Antenna
 Mode: Tx 5.6 GHz Band_1In 40 MHz

Test Equipment:

Horn 1-18GHz T60; S/N: 2238 @3m	Pre-amplifier 1-26GHz T34 HP 8449B	Pre-amplifier 26-40GHz	Horn > 18GHz	Limit FCC 15.205
------------------------------------	---------------------------------------	------------------------	--------------	---------------------

Hi Frequency Cables

2 foot cable	3 foot cable Vien 187215002	12 foot cable Ninous 208946002	HPF HPF_7.6GHz	Reject Filter	Peak Measurements RBW=VBW=1MHz Average Measurements RBW=1MHz ; VBW=10Hz
--------------	--------------------------------	-----------------------------------	-------------------	---------------	--

f GHz	Dist (m)	Read Pk dBuV	Read Avg dBuV	AF dB/m	CL dB	Amp dB	D Corr dB	Filtr dB	Peak dBuV/m	Avg dBuV/m	Pk Lim dBuV/m	Avg Lim dBuV/m	Pk Mar dB	Avg Mar dB	Notes (V/H)
LOW CHANNEL, 5510 MHz															
11.020	3.0	51.7	39.5	37.3	3.9	-32.6	0.0	0.7	61.1	48.9	74	54	-12.9	-5.1	H
11.020	3.0	52.6	41.2	37.3	3.9	-32.6	0.0	0.7	62.0	50.6	74	54	-12.0	-3.4	V
MID CHANNEL, 5590 MHz															
11.180	3.0	41.1	38.8	37.3	3.9	-32.6	0.0	0.7	50.6	48.3	74	54	-23.4	-5.7	H
11.180	3.0	50.9	39.9	37.3	3.9	-32.6	0.0	0.7	60.4	49.4	74	54	-13.6	-4.6	V
HI CHANNEL, 5670 MHz															
11.340	3.0	48.3	37.3	37.4	3.9	-32.6	0.0	0.7	57.8	46.8	74	54	-16.2	-7.2	H
11.340	3.0	48.5	37.9	37.4	3.9	-32.6	0.0	0.7	58.0	47.4	74	54	-16.0	-6.6	V

No other emissions were detected above system noise floor

f	Measurement Frequency	Amp	Preamp Gain	Avg Lim	Average Field Strength Limit
Dist	Distance to Antenna	D Corr	Distance Correct to 3 meters	Pk Lim	Peak Field Strength Limit
Read	Analyzer Reading	Avg	Average Field Strength @ 3 m	Avg Mar	Margin vs. Average Limit
AF	Antenna Factor	Peak	Calculated Peak Field Strength	Pk Mar	Margin vs. Peak Limit
CL	Cable Loss	HPF	High Pass Filter		

10.5. RECEIVER ABOVE 1 GHZ

10.5.1. 20 MHz BANDWIDTH

High Frequency Measurement Compliance Certification Services																
Company: Broadcom Project #: 07U11529 Date: 12/20/2007 Test Engineer: Vien Tran Configuration: EUT with 3.9dBi Antenna Mode: Rx 5.2 GHz Band_20 MHz BW Worst-Case																
Test Equipment:																
Horn 1-18GHz			Pre-amplifier 1-26GHz			Pre-amplifier 26-40GHz			Horn > 18GHz			Limit				
T60; S/N: 2238 @3m			T34 HP 8449B									RX RSS 210				
Hi Frequency Cables																
2 foot cable			3 foot cable			12 foot cable			HPF		Reject Filter		Peak Measurements RBW=VBW=1MHz Average Measurements RBW=1MHz ; VBW=10Hz			
William 177079009						Ninous 208946002										
f GHz	Dist (m)	Read Pk dBuV	Read Avg dBuV	AF dB/m	CL dB	Amp dB	D Corr dB	Fltr dB	Peak dBuV/m	Avg dBuV/m	Pk Lim dBuV/m	Avg Lim dBuV/m	Pk Mar dB	Avg Mar dB	Notes (V/H)	
1.988	3.0	68.4	43.7	27.9	2.1	-36.9	0.0	0.0	61.5	36.8	74	54	-12.5	-17.2	H	
2.490	3.0	59.2	39.8	28.8	2.3	-36.3	0.0	0.0	54.1	34.6	74	54	-19.9	-19.4	H	
1.298	3.0	58.8	40.6	26.2	1.8	-37.8	0.0	0.0	48.9	30.7	74	54	-25.1	-23.3	H	
1.988	3.0	70.9	46.1	27.9	2.1	-36.9	0.0	0.0	64.0	39.2	74	54	-10.0	-14.8	V	
2.490	3.0	61.6	42.2	28.8	2.3	-36.3	0.0	0.0	56.5	37.1	74	54	-17.5	-16.9	V	
1.298	3.0	61.2	43.0	26.2	1.8	-37.8	0.0	0.0	51.3	33.1	74	54	-22.7	-20.9	V	
No other emissions were detected above sytem noise floor																
f	Measurement Frequency					Amp	Preamp Gain					Avg Lim	Average Field Strength Limit			
Dist	Distance to Antenna					D Corr	Distance Correct to 3 meters					Pk Lim	Peak Field Strength Limit			
Read	Analyzer Reading					Avg	Average Field Strength @ 3 m					Avg Mar	Margin vs. Average Limit			
AF	Antenna Factor					Peak	Calculated Peak Field Strength					Pk Mar	Margin vs. Peak Limit			
CL	Cable Loss					HPF	High Pass Filter									

10.5.2. 40 MHz BANDWIDTH

High Frequency Measurement
 Compliance Certification Services

Company: Broadcom
 Project #: 07U11529
 Date: 12/20/2007
 Test Engineer: Vien Tran
 Configuration: EUT with 3.9dBi Antenna
 Mode: Rx 5.2 GHz Band_40 MHz BW Worst-Case

Test Equipment:

Horn 1-18GHz T60; S/N: 2238 @3m	Pre-amplifer 1-26GHz T34 HP 8449B	Pre-amplifer 26-40GHz	Horn > 18GHz	Limit RX RSS 210
------------------------------------	--------------------------------------	-----------------------	--------------	---------------------

Hi Frequency Cables

2 foot cable William 177079009	3 foot cable	12 foot cable Ninous 208946002	HPF	Reject Filter	Peak Measurements RBW=VBW=1MHz Average Measurements RBW=1MHz ; VBW=10Hz
-----------------------------------	--------------	-----------------------------------	-----	---------------	--

f GHz	Dist (m)	Read Pk dBuV	Read Avg. dBuV	AF dB/m	CL dB	Amp dB	D Corr dB	Ftr dB	Peak dBuV/m	Avg dBuV/m	Pk Lim dBuV/m	Avg Lim dBuV/m	Pk Mar dB	Avg Mar dB	Notes (V/H)
1.988	3.0	67.0	41.1	27.9	2.1	-36.9	0.0	0.0	60.1	34.2	74	54	-13.9	-19.8	H
2.490	3.0	61.1	44.2	28.8	2.3	-36.3	0.0	0.0	56.0	39.1	74	54	-18.0	-14.9	H
1.298	3.0	59.4	45.3	26.2	1.8	-37.8	0.0	0.0	49.5	35.4	74	54	-24.5	-18.6	H
1.988	3.0	72.0	41.9	27.9	2.1	-36.9	0.0	0.0	65.1	35.0	74	54	-8.9	-19.0	V
2.490	3.0	63.3	47.4	28.8	2.3	-36.3	0.0	0.0	58.2	42.3	74	54	-15.8	-11.7	V
1.298	3.0	53.4	37.3	26.2	1.8	-37.8	0.0	0.0	43.5	27.4	74	54	-30.5	-26.6	V

No other emissions were detected above sytem noise floor

f	Measurement Frequency	Amp	Preamp Gain	Avg Lim	Average Field Strength Limit
Dist	Distance to Antenna	D Corr	Distance Correct to 3 meters	Pk Lim	Peak Field Strength Limit
Read	Analyzer Reading	Avg	Average Field Strength @ 3 m	Avg Mar	Margin vs. Average Limit
AF	Antenna Factor	Peak	Calculated Peak Field Strength	Pk Mar	Margin vs. Peak Limit
CL	Cable Loss	HPF	High Pass Filter		

10.6. WORST-CASE BELOW 1 GHz

SPURIOUS EMISSIONS 30 TO 1000 MHz (WORST-CASE CONFIGURATION, HORIZONTAL)

HORIZONTAL DATA



Compliance Certification Services
47173 Benicia Street
Fremont, CA 94538
Tel: (510) 771-1000
Fax: (510) 661-0888

Data#: 20 File#: 30-1000M.EMI Date: 01-09-2008 Time: 13:06:04

Condition: FCC CLASS-B HORIZONTAL
Test Operator: Vien Tran
Project # : 07U11529
Company : Broadcom
Config : EUT on extended card
Mode : Tx, 5 GHz Band (worst case)
Target : FCC CLASS B

Page: 1

	Freq	Read Level	Factor	Level	Limit Line	Over Limit	Remark
	MHz	dBuV	dB	dBuV/m	dBuV/m	dB	
1	138.640	48.75	-13.21	35.53	43.50	-7.97	Peak
2	342.340	53.09	-11.22	41.87	46.00	-4.13	Peak
3	455.830	46.73	-8.40	38.33	46.00	-7.67	Peak
4	633.340	44.44	-4.77	39.67	46.00	-6.33	Peak
5	906.880	40.22	-1.05	39.17	46.00	-6.83	Peak

SPURIOUS EMISSIONS 30 TO 1000 MHz (WORST-CASE CONFIGURATION, VERTICAL)

VERTICAL DATA



Compliance Certification Services
47173 Benicia Street
Fremont, CA 94538
Tel: (510) 771-1000
Fax: (510) 661-0888

Data#: 22 File#: 30-1000M.EMI Date: 01-09-2008 Time: 12:56:01

Condition: FCC CLASS-B VERTICAL
Test Operator: Vien Tran
Project # : 07U11529
Company : Broadcom
Config : EUT on extended card
Mode : Tx, 5 GHz Band (worst case)
Target : FCC CLASS B

Page: 1

	Freq	Read Level	Factor	Level	Limit Line	Over Limit	Remark
	MHz	dBuV	dB	dBuV/m	dBuV/m	dB	
1	124.090	43.57	-13.05	30.52	43.50	-12.98	Peak
2	148.340	44.20	-13.74	30.46	43.50	-13.04	Peak
3	368.530	44.55	-10.59	33.96	46.00	-12.04	Peak
4	552.830	46.73	-6.30	40.43	46.00	-5.57	Peak
5	906.880	40.03	-1.05	38.98	46.00	-7.02	Peak

11. DYNAMIC FREQUENCY SELECTION

11.1. OVERVIEW

11.1.1. LIMITS

INDUSTRY CANADA

IC RSS-210 is closely harmonized with FCC Part 15 DFS rules. The deviations are as follows:

RSS-210 Issue 7 A9.4 (b) (ii) **Channel Availability Check Time:** ...

Additional requirements for the band 5600-5650 MHz: Until further notice, devices subject to this Section shall not be capable of transmitting in the band 5600-5650 MHz, so that Environment Canada weather radars operating in this band are protected.

RSS-210 Issue 7 A9.4 (b) (iv) **Channel closing time:** the maximum channel closing time is 260 ms.

FCC

§15.407 (h) and FCC 06-96 APPENDIX "COMPLIANCE MEASUREMENT PROCEDURES FOR UNLICENSED-NATIONAL INFORMATION INFRASTRUCTURE DEVICES OPERATING IN THE 5250-5350 MHz AND 5470-5725 MHz BANDS INCORPORATING DYNAMIC FREQUENCY SELECTION".

Table 1: Applicability of DFS requirements prior to use of a channel

Requirement	Operational Mode		
	Master	Client (without radar detection)	Client (with radar detection)
Non-Occupancy Period	Yes	Not required	Yes
DFS Detection Threshold	Yes	Not required	Yes
Channel Availability Check Time	Yes	Not required	Not required
Uniform Spreading	Yes	Not required	Not required

Table 2: Applicability of DFS requirements during normal operation

Requirement	Operational Mode		
	Master	Client (without DFS)	Client (with DFS)
DFS Detection Threshold	Yes	Not required	Yes
Channel Closing Transmission Time	Yes	Yes	Yes
Channel Move Time	Yes	Yes	Yes

Table 3: Interference Threshold values, Master or Client incorporating In-Service Monitoring

Maximum Transmit Power	Value (see note)
≥ 200 milliwatt	-64 dBm
< 200 milliwatt	-62 dBm
<p>Note 1: This is the level at the input of the receiver assuming a 0 dBi receive antenna</p> <p>Note 2: Throughout these test procedures an additional 1 dB has been added to the amplitude of the test transmission waveforms to account for variations in measurement equipment. This will ensure that the test signal is at or above the detection threshold level to trigger a DFS response.</p>	

Table 4: DFS Response requirement values

Parameter	Value
<i>Non-occupancy period</i>	30 minutes
<i>Channel Availability Check Time</i>	60 seconds
<i>Channel Move Time</i>	10 seconds
<i>Channel Closing Transmission Time</i>	200 milliseconds + approx. 60 milliseconds over remaining 10 second period
<p>The instant that the <i>Channel Move Time</i> and the <i>Channel Closing Transmission Time</i> begins is as follows:</p> <p>For the Short pulse radar Test Signals this instant is the end of the <i>Burst</i>.</p> <p>For the Frequency Hopping radar Test Signal, this instant is the end of the last radar burst generated.</p> <p>For the Long Pulse radar Test Signal this instant is the end of the 12 second period defining the radar transmission.</p> <p>The Channel Closing Transmission Time is comprised of 200 milliseconds starting at the beginning of the Channel Move Time plus any additional intermittent control signals required to facilitate channel changes (an aggregate of approximately 60 milliseconds) during the remainder of the 10 second period. The aggregate duration of control signals will not count quiet periods in between transmissions.</p>	

Table 5 – Short Pulse Radar Test Waveforms

Radar Type	Pulse Width (Microseconds)	PRI (Microseconds)	Pulses	Minimum Percentage of Successful Detection	Minimum Trials
1	1	1428	18	60%	30
2	1-5	150-230	23-29	60%	30
3	6-10	200-500	16-18	60%	30
4	11-20	200-500	12-16	60%	30
Aggregate (Radar Types 1-4)				80%	120

Table 6 – Long Pulse Radar Test Signal

Radar Waveform	Bursts	Pulses per Burst	Pulse Width (µsec)	Chirp Width (MHz)	PRI (µsec)	Minimum Percentage of Successful Detection	Minimum Trials
5	8-20	1-3	50-100	5-20	1000-2000	80%	30

Table 7 – Frequency Hopping Radar Test Signal

Radar Waveform	Pulse Width (µsec)	PRI (µsec)	Burst Length (ms)	Pulses per Hop	Hopping Rate (kHz)	Minimum Percentage of Successful Detection	Minimum Trials
6	1	333	300	9	.333	70%	30

11.1.2. TEST AND MEASUREMENT SYSTEM

RADIATED METHOD SYSTEM BLOCK DIAGRAM

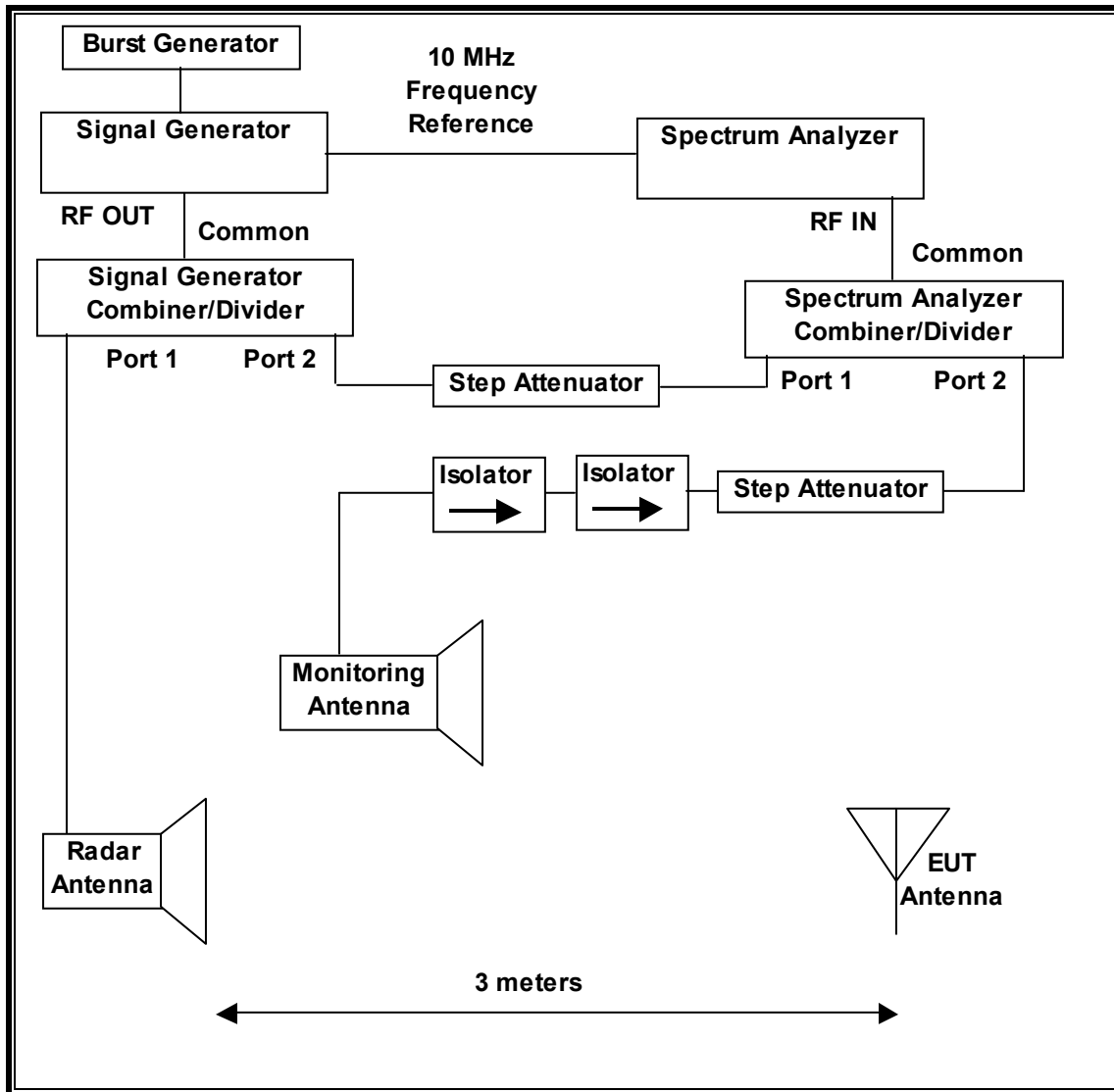

SYSTEM OVERVIEW

The short pulse and long pulse signal generating system utilizes the NTIA software. The Vector Signal Generator has been validated by the NTIA. The hopping signal generating system utilizes the CCS simulated hopping method and system, which has been validated by the DoD, FCC and NTIA. The software selects waveform parameters from within the bounds of the signal type on a random basis using uniform distribution.

The short pulse types 2, 3 and 4, and the long pulse type 5 parameters are randomized at run-time.

The hopping type 6 pulse parameters are fixed while the hopping sequence is based on the August 2005 NTIA Hopping Frequency List. The initial starting point randomized at run-time and each subsequent starting point is incremented by 475. Each frequency in the 100-length segment is compared to the boundaries of the EUT Detection Bandwidth and the software creates a hopping burst pattern in accordance with Section 7.4.1.3 Method #2 Simulated Frequency Hopping Radar Waveform Generating Subsystem of FCC 06-96 APPENDIX. The frequency of the signal generator is incremented in 1 MHz steps from F_L to F_H for each successive trial. This incremental sequence is repeated as required to generate a minimum of 30 total trials and to maintain a uniform frequency distribution over the entire Detection Bandwidth.

The signal monitoring equipment consists of a spectrum analyzer set to display 8001 bins on the horizontal axis. The time-domain resolution is 2 msec / bin with a 16 second sweep time, meeting the 10 second short pulse reporting criteria. The aggregate ON time is calculated by multiplying the number of bins above a threshold during a particular observation period by the dwell time per bin, with the analyzer set to peak detection and max hold.

Should multiple RF ports be utilized for the Master and/or Slave devices (for example, for diversity or MIMO implementations), additional combiner/dividers are inserted between the Master Combiner/Divider and the pad connected to the Master Device (and/or between the Slave Combiner/Divider and the pad connected to the Slave Device). Additional pads are utilized such that there is one pad at each RF port on each EUT.

SYSTEM CALIBRATION

A 50-ohm load is connected in place of the spectrum analyzer, and the spectrum analyzer is connected to a horn antenna via a coaxial cable, with the reference level offset set to (horn antenna gain – coaxial cable loss). The signal generator is set to CW mode. The amplitude of the signal generator is adjusted to yield a level of –64 dBm as measured on the spectrum analyzer.

Without changing any of the instrument settings, the spectrum analyzer is reconnected to the Common port of the Spectrum Analyzer Combiner/Divider. Measure the amplitude and calculate the difference from -64 dBm. Adjust the Reference Level Offset of the spectrum analyzer to this difference.

The spectrum analyzer displays the level of the signal generator as received at the antenna ports of the Master Device. The interference detection threshold may be varied from the calibrated value of -64 dBm and the spectrum analyzer will still indicate the level as received by the Master Device.

Set the signal generator to produce a radar waveform, trigger a burst manually and measure the level on the spectrum analyzer. Readjust the amplitude of the signal generator as required so that the peak level of the waveform is at a displayed level equal to the required or desired interference detection threshold. Separate signal generator amplitude settings are determined as required for each radar type.

ADJUSTMENT OF DISPLAYED TRAFFIC LEVEL

Establish a link between the Master and Slave, adjusting the distance between the units as needed to provide a suitable received level at the Master and Slave devices. Stream the video test file to generate WLAN traffic. Confirm that the WLAN traffic level, as displayed on the spectrum analyzer, is at lower amplitude than the radar detection threshold. For Master Device testing confirm that the displayed traffic does not include Slave Device traffic. For Slave Device testing confirm that the displayed traffic does not include Master Device traffic.

If a different setting of the Step Attenuators are required to meet the above conditions, perform a new System Calibration for the new Step Attenuator settings.

TEST AND MEASUREMENT EQUIPMENT

The following test and measurement equipment was utilized for the DFS tests documented in this report:

TEST EQUIPMENT LIST				
Description	Manufacturer	Model	Asset Number	Cal Due
Spectrum Analyzer, 44 GHz	Agilent / HP	E4446A	C00986	05/30/09
Vector Signal Generator 250kHz-20GHz	Agilent / HP	E8267C	C01066	11/16/2009

11.1.3. SETUP OF EUT

RADIATED METHOD EUT TEST SETUP

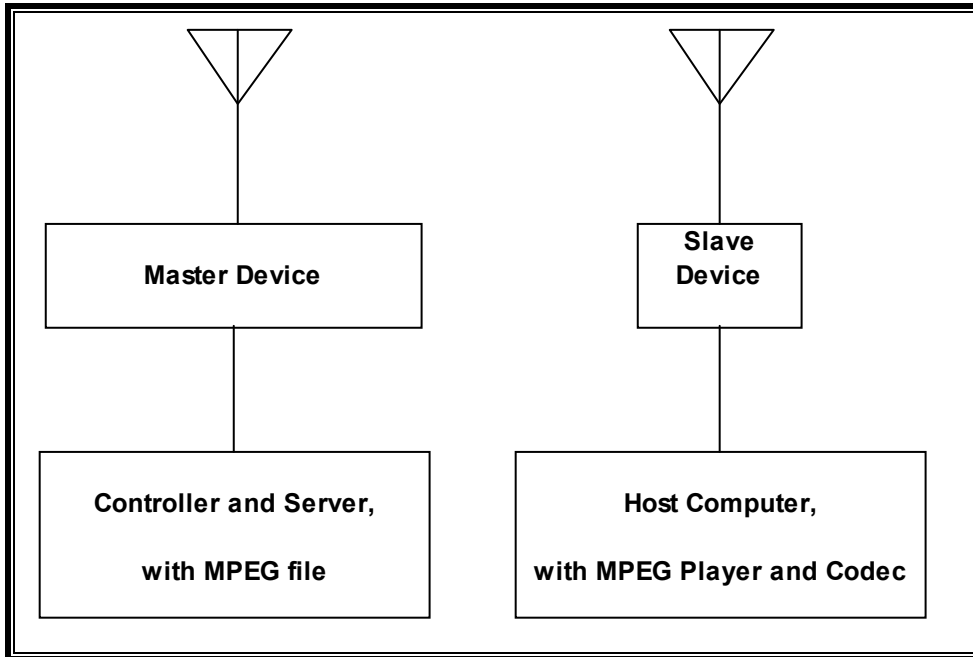

SUPPORT EQUIPMENT

The following support equipment was utilized for the 20 MHz bandwidth DFS tests documented in this report:

PERIPHERAL SUPPORT EQUIPMENT LIST				
Description	Manufacturer	Model	Serial Number	FCC ID
Laptop	DELL	Dell Inspiron 4150	CN-04P449-48643-2CH-2011	DoC
AC Adapter	DELL	ADP-70EB	TH-09364U-17971-248-8PDP	DoC
Laptop	Compaq	Presario 3000	CNU327025L	DoC
AC Adapter	Compaq	PA-1900-05H	3300371601	DoC
Access Point	CISCO	AIR-AP1242AG-A-K9	FTX1042B5E0	LDK102056
AC Adapter	Delta	ADP-18PB	PZT0628359656	DoC

The following support equipment was utilized for the 40 MHz bandwidth DFS tests documented in this report:

PERIPHERAL SUPPORT EQUIPMENT LIST				
Description	Manufacturer	Model	Serial Number	FCC ID
Laptop	HP	PA-1121-12HD	PPP017L	DoC
AC Adapter	HP	HP Pavilion zv6000	CND52904s1	DoC
Laptop	DELL	ADP-70EB	TH-09364U-17971-248-8PDP	DoC
AC Adapter	DELL	Dell Inspiron 4150	CN-04P449-48643-2CH-2011	DoC
Access Point	Broadcom	BCM94705LMP	Prototype	QDS-BRCM1025
AC Adapter	Bothhand	M1-10S05	R00031106975B	DoC

11.1.4. DESCRIPTION OF EUT

The EUT operates over the 5250-5350 MHz and 5470-5725 MHz ranges.

The EUT is a Slave Device without radar detection.

The highest power level within these bands is 28.86 dBm EIRP in the 5250-5350 MHz band and 29.08 dBm EIRP in the 5470-5725 MHz band based on the maximum array gain.

Each antenna assembly utilized with the EUT has a gain of 5.6 dBi for the 5250-5350 MHz band and 4.2 dBi in the 5470-5725 MHz band.

All antennas are integral. Two identical antennas are utilized to meet the MIMO transmit diversity operational requirements.

The EUT uses two transmitters, each connected to their respective antenna. The system is set up to perform radiated tests.

WLAN traffic is generated by streaming the video file TestFile.mp2 "6 ½ Magic Hours" from the Master to the Slave in full motion video mode using the media player with the V2.61 Codec package.

TPC is required since the maximum EIRP is greater than 500 mW (27 dBm).

The EUT utilizes the 802.11a / 802.11n architecture. Two nominal channel bandwidths, 20 MHz and 40 MHz, are implemented.

DESCRIPTION OF TPC FUNCTION

The power level can be reduced to a conducted level of 15 dBm, which yields a maximum EIRP of 23.6 dBm based on the maximum array gain, which is less than the 24 dBm EIRP limit for TPC level.

OVERVIEW OF MASTER DEVICE UTILIZED FOR 20 MHz BANDWIDTH TESTS WITH RESPECT TO §15.407 (h) REQUIREMENTS

The Master Device is a Cisco Access Point, FCC ID: LDK102056. The DFS software installed in the Master Device is revision 6.00.1. The minimum antenna gain for the Master Device is 3.5 dBi.

The rated output power of the Master unit is $> 23\text{dBm}$ (EIRP). Therefore the required interference threshold level is -64 dBm . After correction for antenna gain and procedural adjustments, the required conducted threshold at the antenna port is $-64 + 2 + 1 = -61\text{ dBm}$.

The calibrated conducted DFS Detection Threshold level is set to -64 dBm . The tested level is lower than the required level hence it provides margin to the limit.

OVERVIEW OF MASTER DEVICE UTILIZED FOR 40 MHz BANDWIDTH TESTS WITH RESPECT TO §15.407 (h) REQUIREMENTS

The Master Device is a Broadcom Access Point, FCC ID: QDS-BRCM1025. The DFS software installed in the Master Device is revision PO_4_100_22_2. The minimum antenna gain for the Master Device is 3 dBi.

The rated output power of the Master unit is $< 23\text{ dBm}$ (EIRP). Therefore the required interference threshold level is -62 dBm . After correction for antenna gain and procedural adjustments, the required conducted threshold at the antenna port is $-62 + 3 + 1 = -58\text{dBm}$.

The calibrated conducted DFS Detection Threshold level is set to -64 dBm . The tested level is lower than the required level hence it provides margin to the limit.

11.2. RESULTS FOR 20 MHz BANDWIDTH

11.2.1. TEST CHANNEL

All tests were performed at a channel center frequency of 5300 MHz. Measurements were performed using conducted test methods.

11.2.2. PLOTS OF RADAR WAVEFORM AND WLAN TRAFFIC

PLOTS OF RADAR WAVEFORM

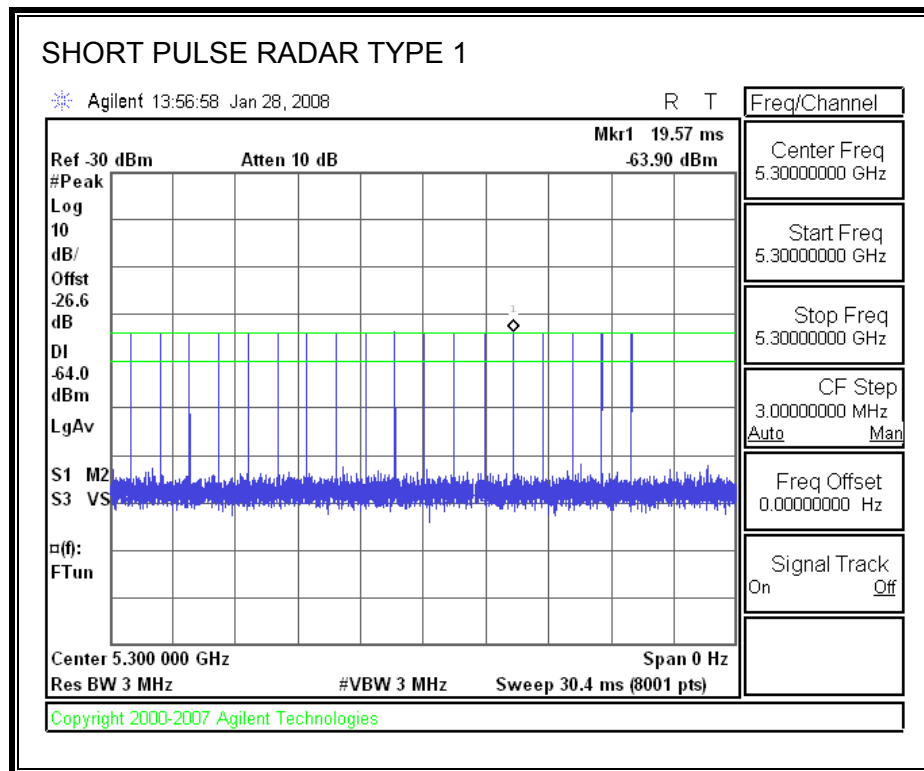

PLOT OF WLAN TRAFFIC

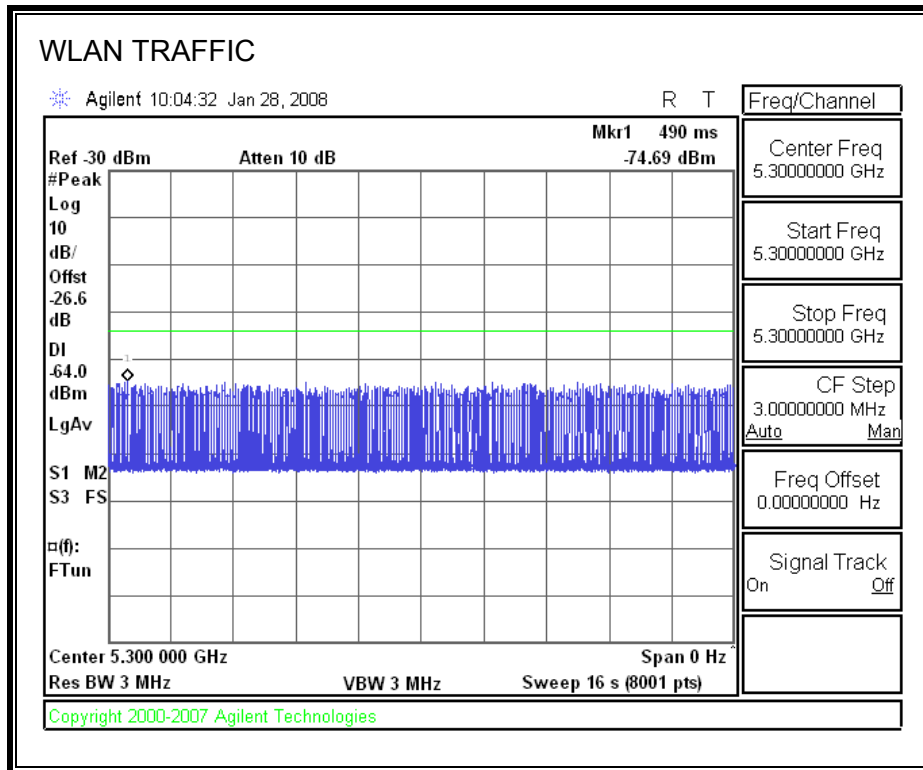

11.2.3. MOVE AND CLOSING TIME

REPORTING NOTES

The reference marker is set at the end of last radar pulse.

The delta marker is set at the end of the last WLAN transmission following the radar pulse. This delta is the channel move time.

The aggregate channel closing transmission time is calculated as follows:

Aggregate Transmission Time =

(Number of analyzer bins showing transmission) * (dwell time per bin)

The observation period over which the FCC aggregate time is calculated begins at (Reference Marker + 200 msec) and ends no earlier than (Reference Marker + 10 sec).

The observation period over which the IC aggregate time is calculated begins at (Reference Marker) and ends no earlier than (Reference Marker + 10 sec).

RESULTS

Agency	Channel Move Time (sec)	Limit (sec)
FCC / IC	3.9	10

Agency	Aggregate Channel Closing Transmission Time (msec)	Limit (msec)
FCC	56.0	60
IC	57.0	260

MOVE TIME

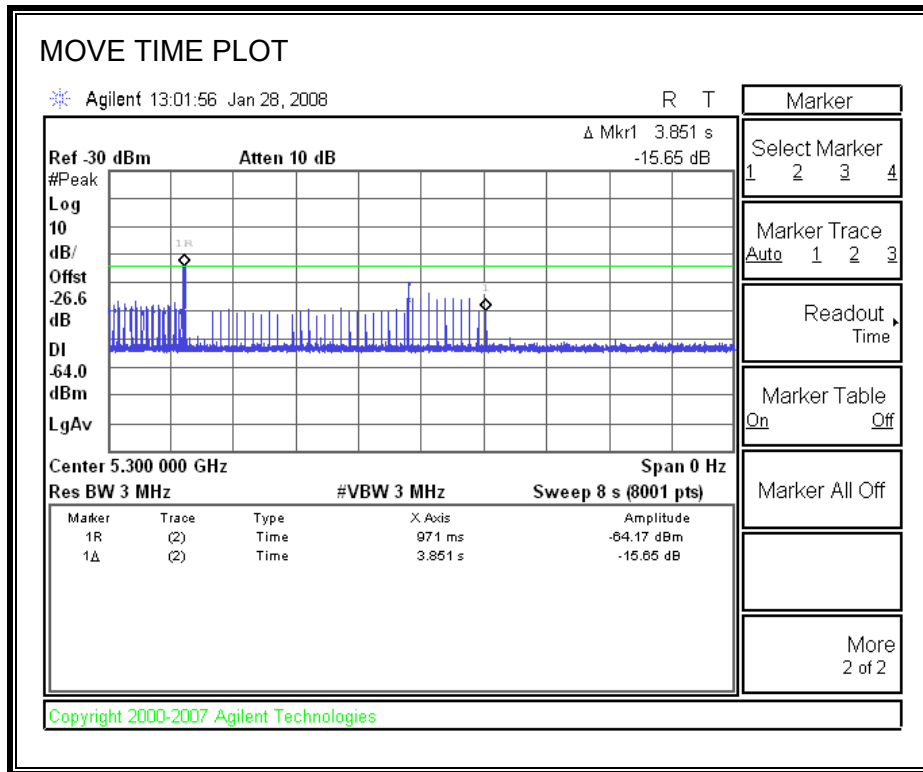

CHANNEL CLOSING TIME

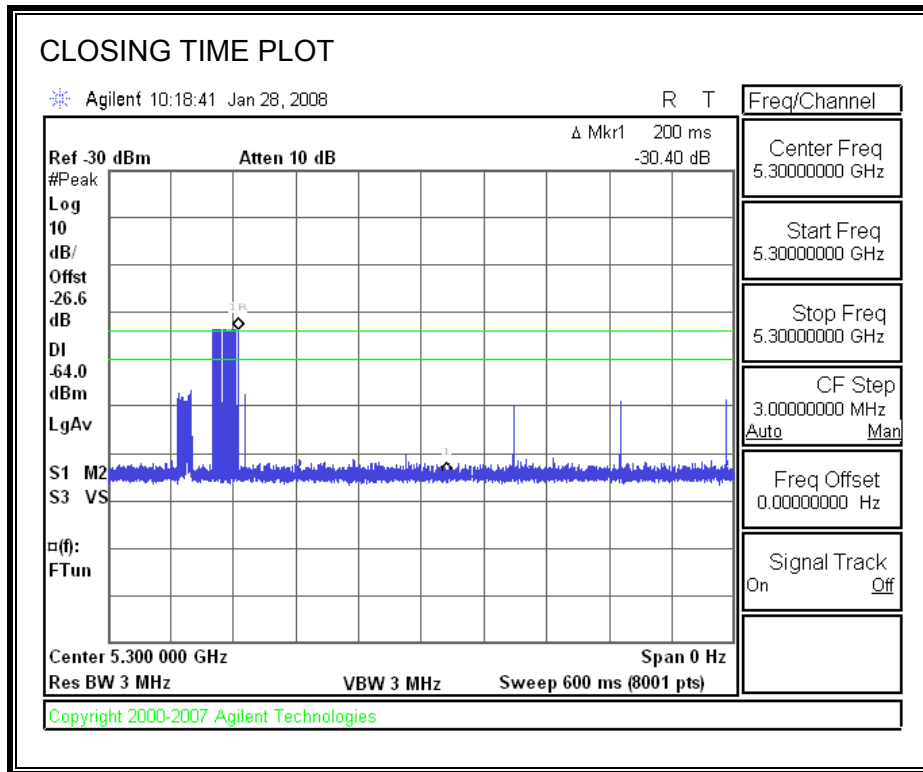

AGGREGATE CHANNEL CLOSING TRANSMISSION TIME

Only intermittent transmissions are observed during the FCC aggregate monitoring period.

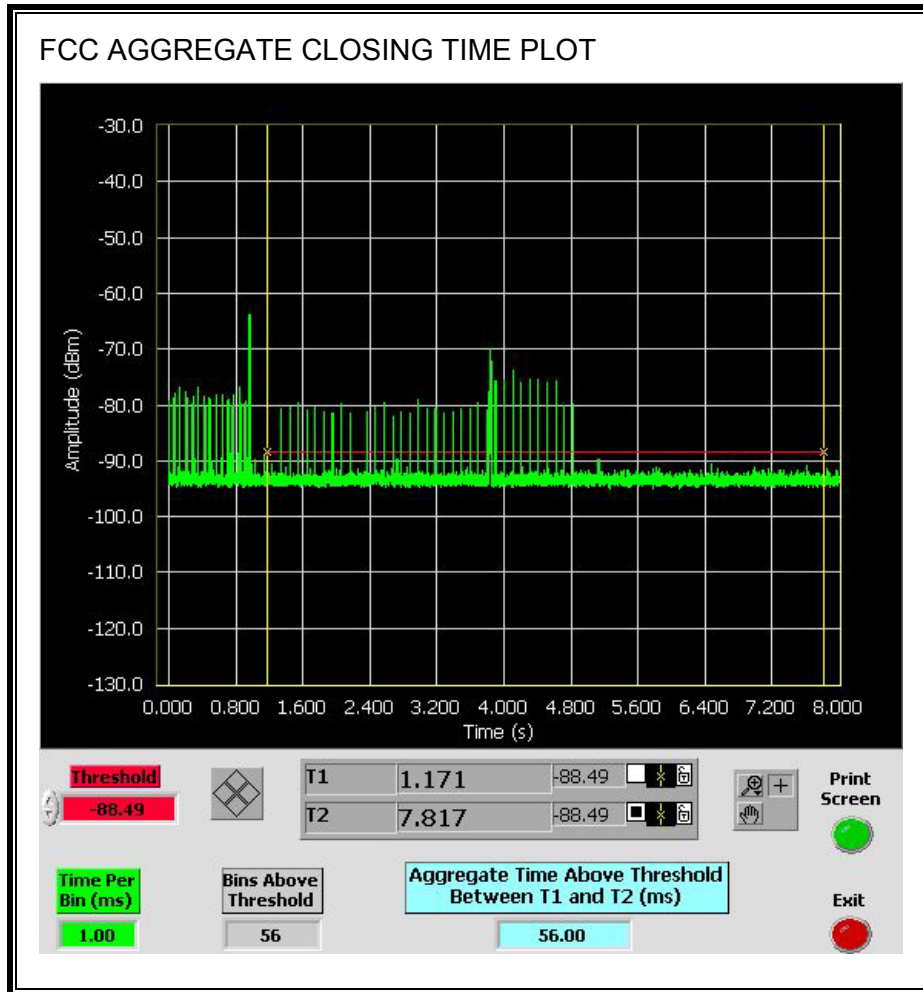

Only intermittent transmissions are observed during the IC aggregate monitoring period.

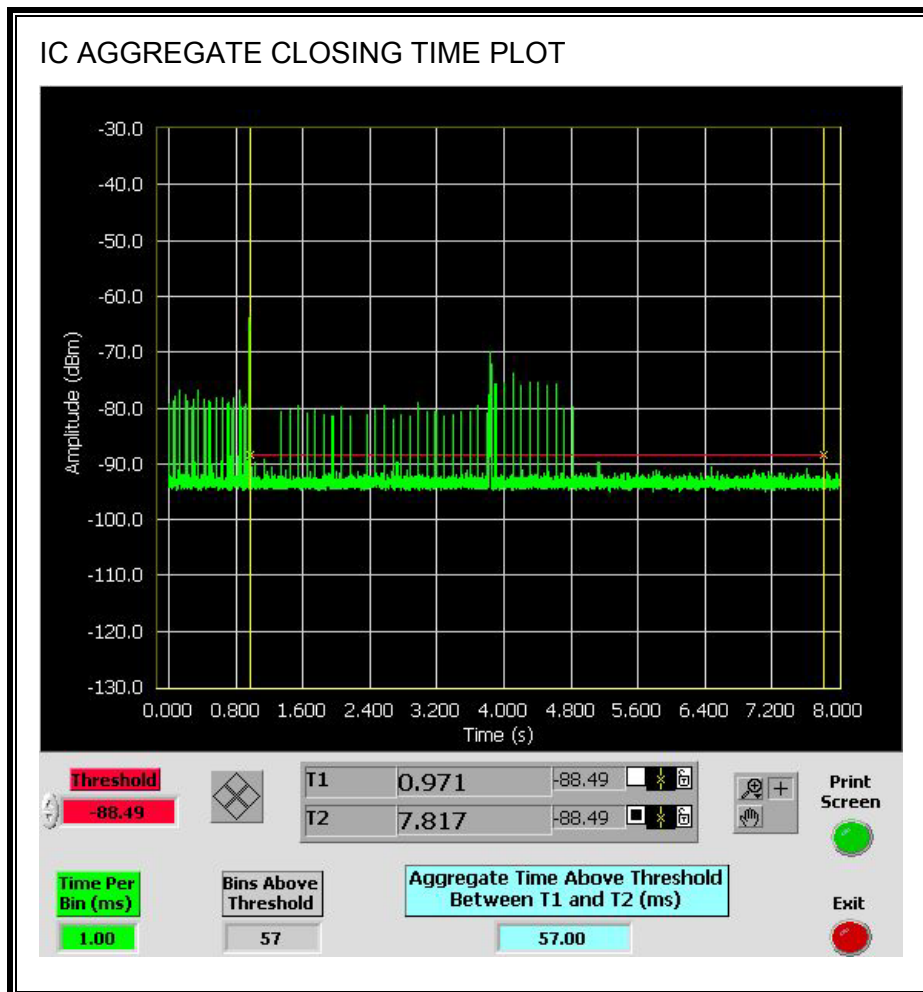

11.2.4. SLAVE NON-OCCUPANCY

TEST PROCEDURE

The spectrum analyzer is monitoring the emissions from the Slave.

The AP and Slave are linked in a 20 MHz bandwidth mode, with streaming video. The spectrum analyzer trace is started, then the radar is triggered, and the channel is monitored for > 30 minutes.

Then the AP is powered down. The spectrum analyzer trace is started, then the Slave is rebooted, and the channel is monitored for > 30 minutes.

ASSOCIATED TEST RESULTS

No EUT transmissions were observed on the test channel during the 30-minute observation time.

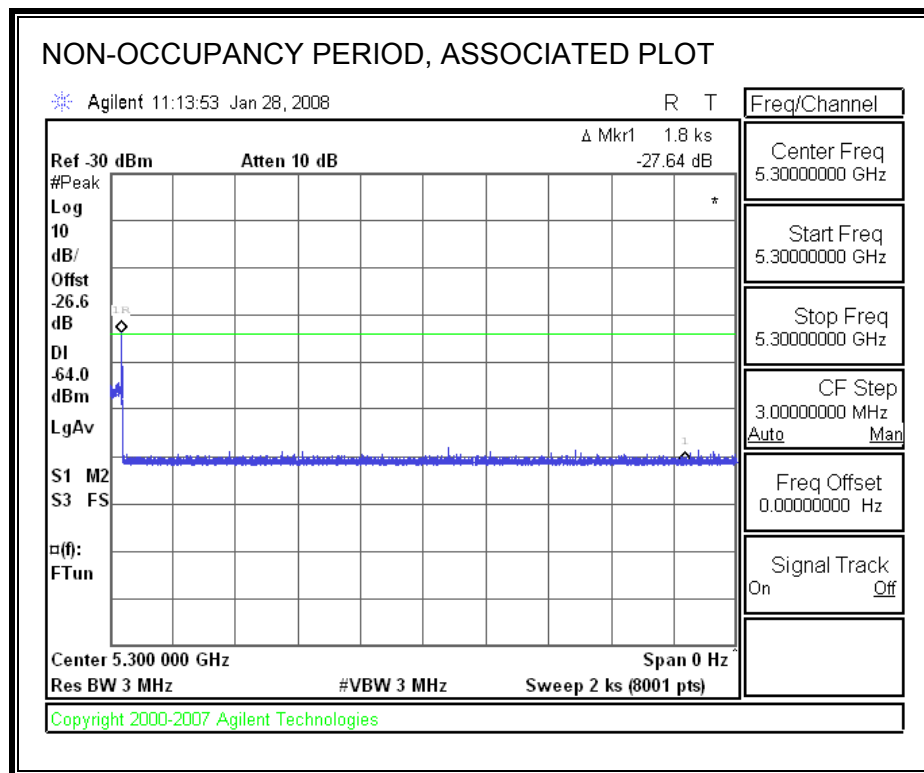

NON-ASSOCIATED TEST RESULTS

No EUT transmissions were observed on the test channel during the 30-minute observation time.

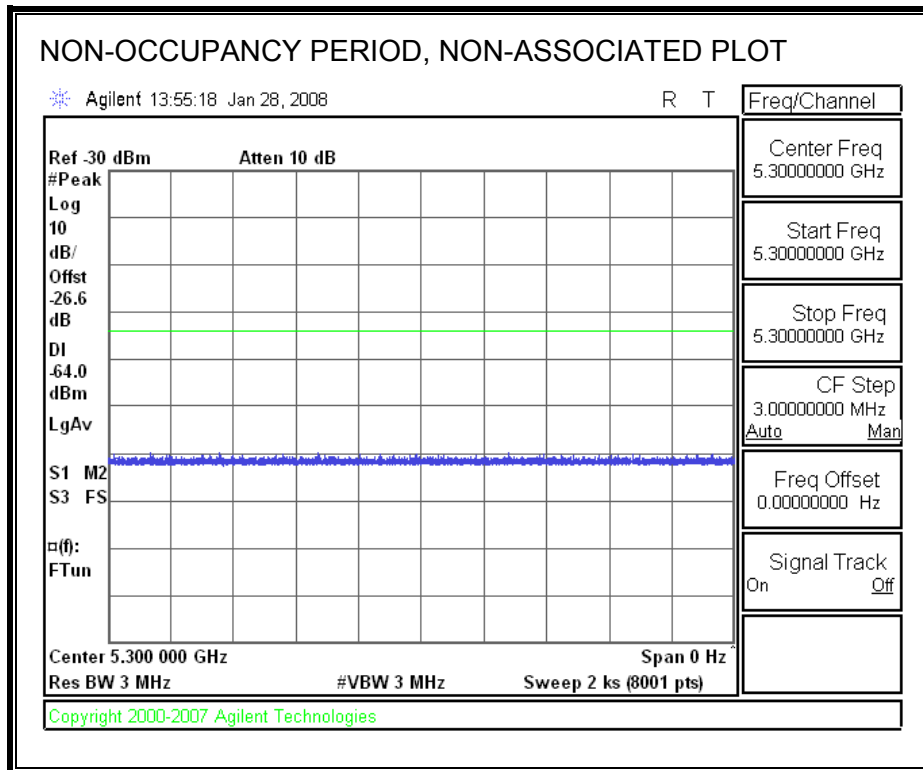

11.3. RESULTS FOR 40 MHz BANDWIDTH

11.3.1. TEST CHANNEL

All tests were performed at a channel center frequency of 5310 MHz. Measurements were performed using conducted test methods.

11.3.2. PLOTS OF RADAR WAVEFORM AND WLAN TRAFFIC

PLOTS OF RADAR WAVEFORM

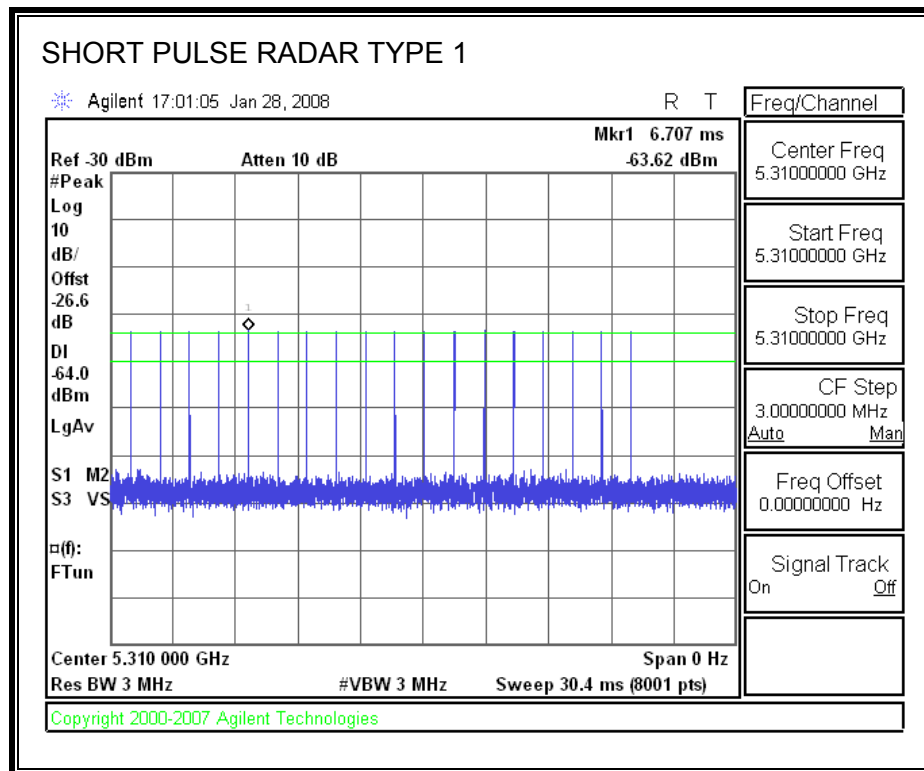

PLOT OF WLAN TRAFFIC

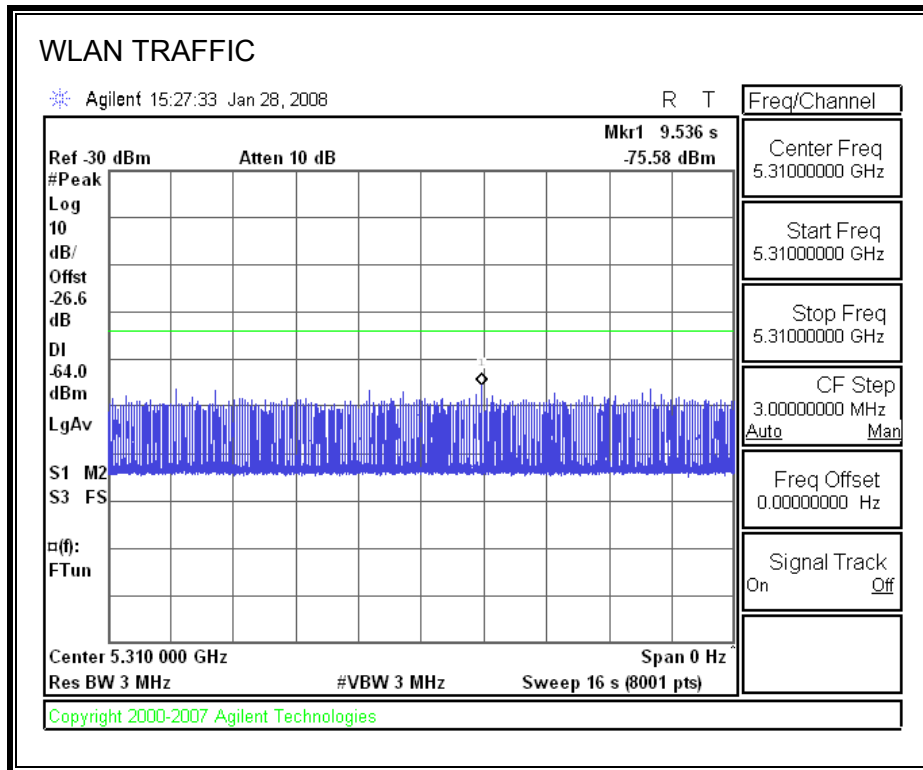

11.3.3. MOVE AND CLOSING TIME

REPORTING NOTES

The reference marker is set at the end of last radar pulse.

The delta marker is set at the end of the last WLAN transmission following the radar pulse. This delta is the channel move time.

The aggregate channel closing transmission time is calculated as follows:

Aggregate Transmission Time =
 (Number of analyzer bins showing transmission) * (dwell time per bin)

The observation period over which the FCC aggregate time is calculated begins at (Reference Marker + 200 msec) and ends no earlier than (Reference Marker + 10 sec).

The observation period over which the IC aggregate time is calculated begins at (Reference Marker) and ends no earlier than (Reference Marker + 10 sec).

RESULTS

Agency	Channel Move Time (sec)	Limit (sec)
FCC / IC	3.1	10

Agency	Aggregate Channel Closing Transmission Time (msec)	Limit (msec)
FCC	56.0	60
IC	72.0	260

MOVE TIME

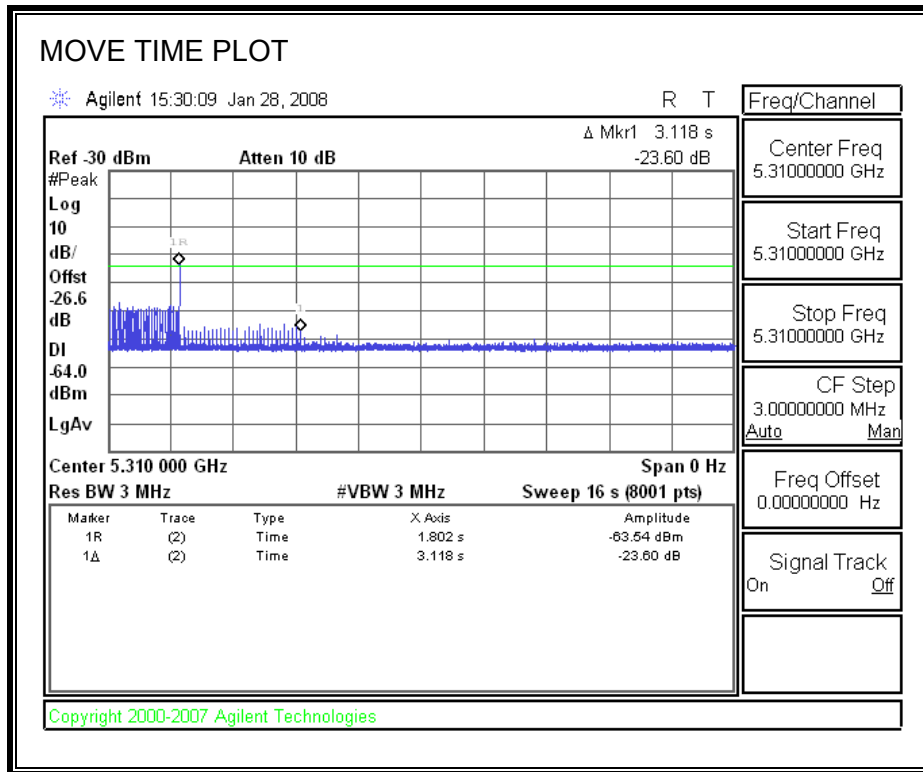

CHANNEL CLOSING TIME

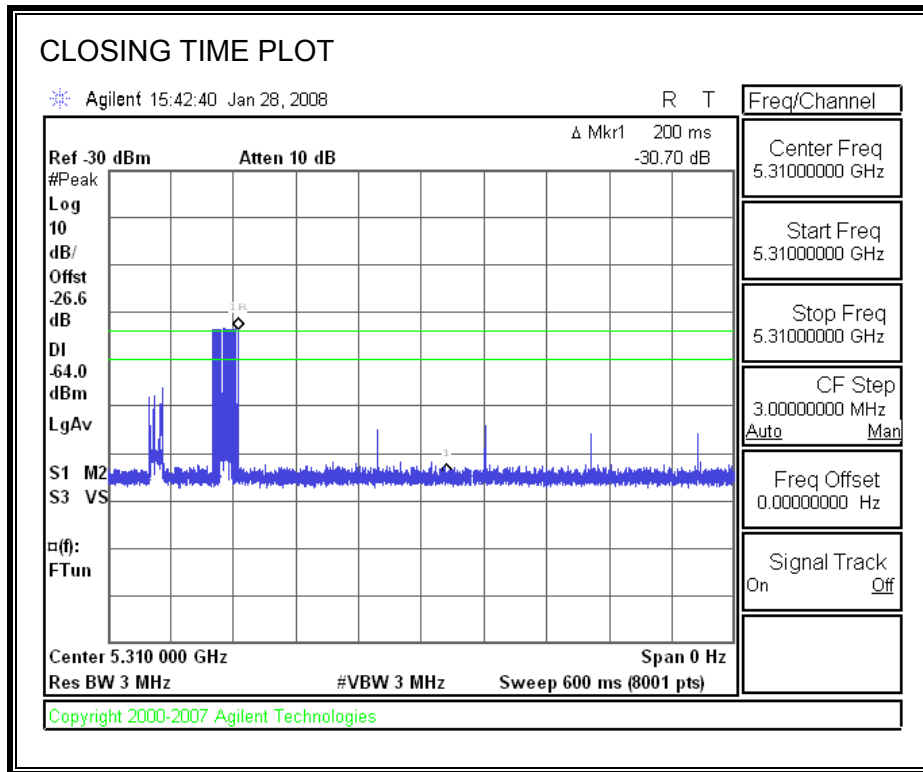

AGGREGATE CHANNEL CLOSING TRANSMISSION TIME

Only intermittent transmissions are observed during the FCC aggregate monitoring period.

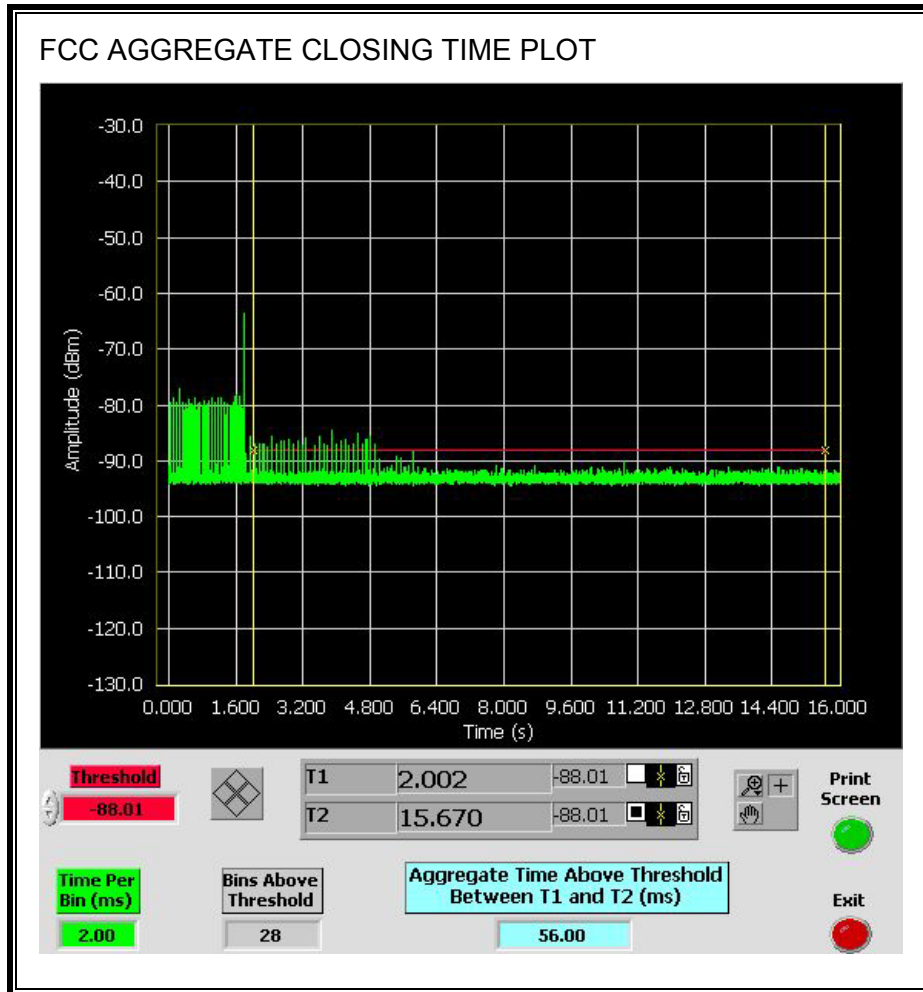

Only intermittent transmissions are observed during the IC aggregate monitoring period.

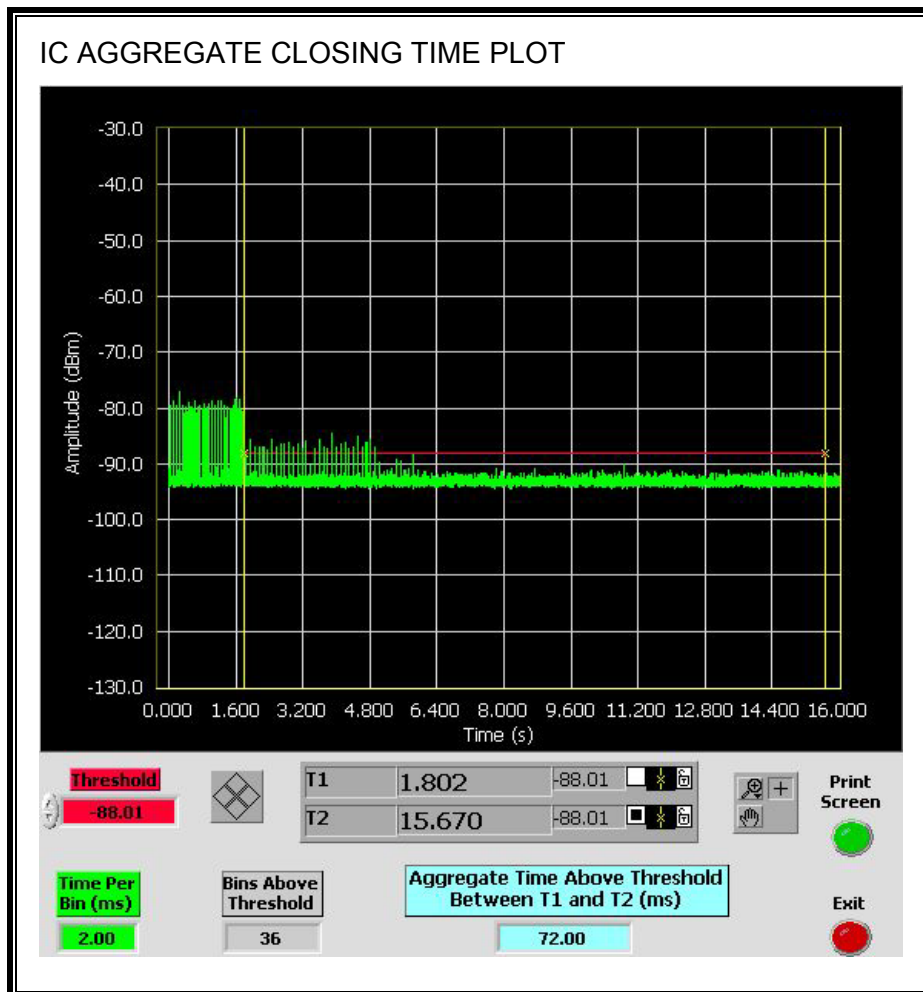

11.3.4. SLAVE NON-OCCUPANCY

TEST PROCEDURE

The spectrum analyzer is monitoring the emissions from the Slave.

The AP and Slave are linked in a 40 MHz bandwidth mode, with streaming video. The spectrum analyzer trace is started, then the radar is triggered, and the channel is monitored for > 30 minutes.

Then the AP is powered down. The spectrum analyzer trace is started, then the Slave is rebooted, and the channel is monitored for > 30 minutes.

ASSOCIATED TEST RESULTS

No EUT transmissions were observed on the test channel during the 30-minute observation time.

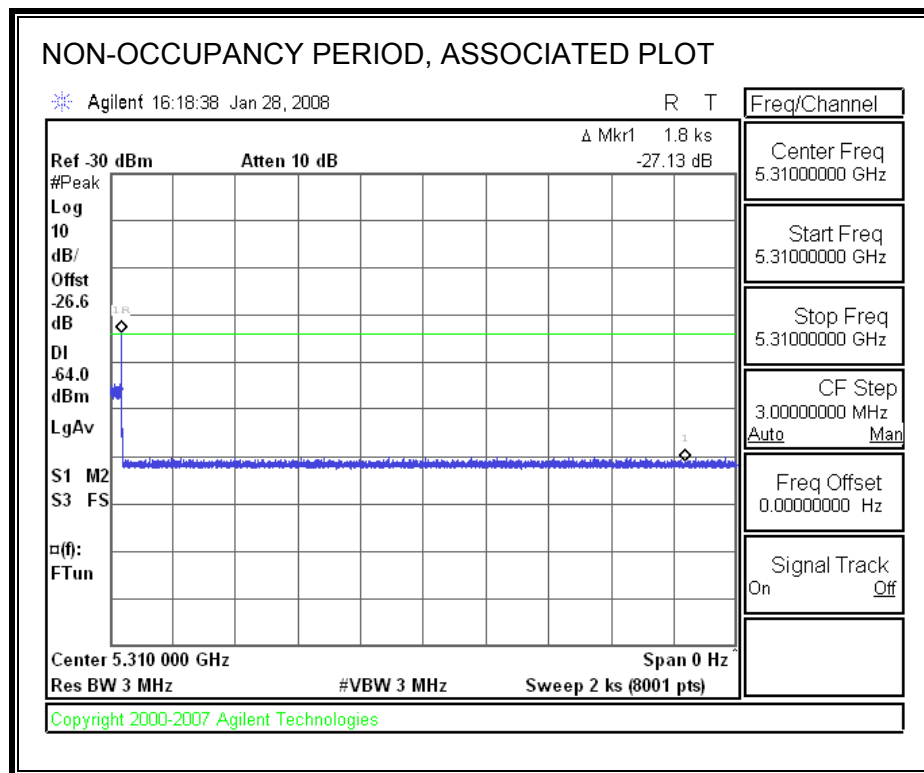

NON-ASSOCIATED TEST RESULTS

No EUT transmissions were observed on the test channel during the 30-minute observation time.

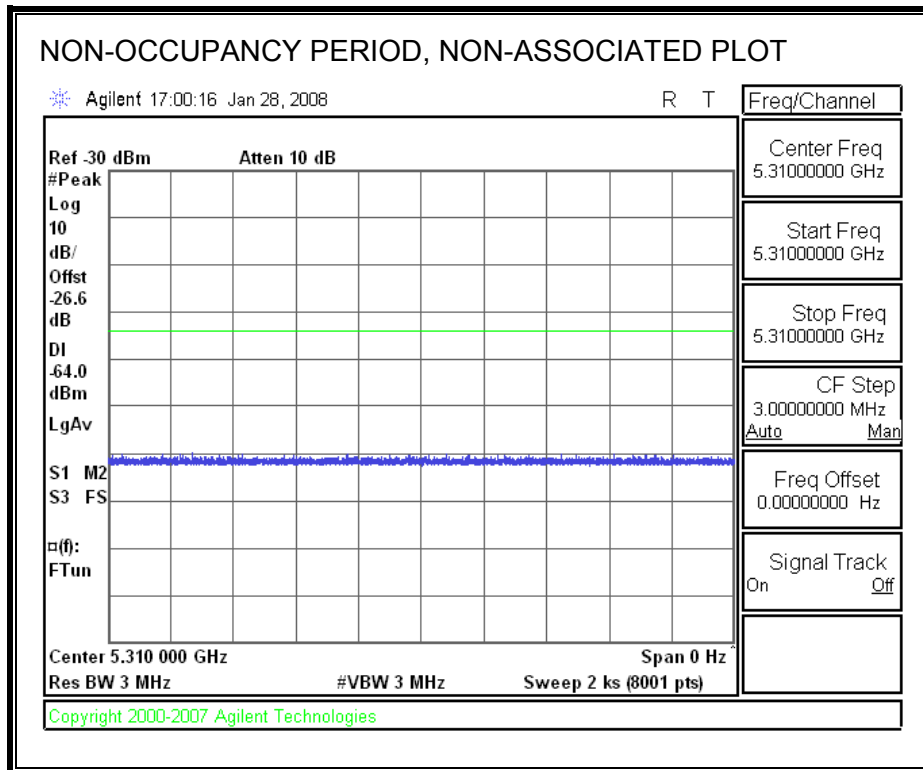

12. AC POWER LINE CONDUCTED EMISSIONS

LIMITS

FCC §15.207 (a)

RSS-Gen 7.2.2

Frequency of Emission (MHz)	Conducted Limit (dBuV)	
	Quasi-peak	Average
0.15-0.5	66 to 56*	56 to 46*
0.5-5	56	46
5-30	60	50

*Decreases with the logarithm of the frequency.

TEST PROCEDURE

The EUT is placed on a non-conducting table 40 cm from the vertical ground plane and 80 cm above the horizontal ground plane. The EUT is configured in accordance with ANSI C63.4.

The receiver is set to a resolution bandwidth of 9 kHz. Peak detection is used unless otherwise noted as quasi-peak or average.

Line conducted data is recorded for both NEUTRAL and HOT lines.

RESULTS

6 WORST EMISSIONS

CONDUCTED EMISSIONS DATA (115VAC 60Hz)									
Freq. (MHz)	Reading			Class (dB)	Limit		Margin		Remark L1 / L2
	PK (dBuV)	QP (dBuV)	AV (dBuV)		QP	AV	QP (dB)	AV (dB)	
0.17	55.90	--	47.70	0.00	65.01	55.01	-9.11	-7.31	L1
0.25	50.83	--	41.10	0.00	61.66	51.66	-10.83	-10.56	L1
0.34	48.18	--	43.10	0.00	59.23	49.23	-11.05	-6.13	L1
0.17	55.83	--	47.36	0.00	65.01	55.01	-9.18	-7.65	L2
0.25	51.98	--	43.03	0.00	61.66	51.66	-9.68	-8.63	L2
0.34	48.25	--	42.10	0.00	59.23	49.23	-10.98	-7.13	L2
6 Worst Data									

LINE 1 RESULTS



Compliance Certification Services
47173 Benicia Street
Fremont, CA 94538
Tel: (510) 771-1000
Fax: (510) 661-0888

Data#: 7 File#: 115V.EMI Date: 12-20-2007 Time: 13:33:18

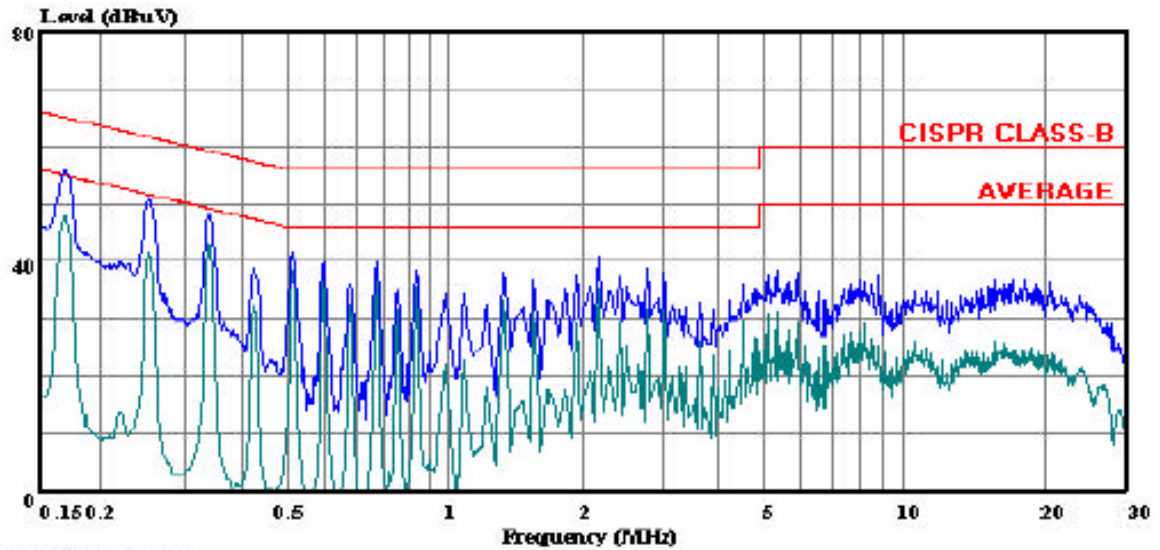

(Line Conduction)

Trace: 5

Ref Trace:

Condition: CISPR CLASS-B
Test Operator: Vien Tran
Project #: 07U11529
Company: Broadcom
Configuration: EUT & 3.9dBi antenna
Mode: Normal
Target: FCC Class B
Voltage: 115VAC/60Hz
L1: Peak (Blue); Average (Green)

LINE 2 RESULTS



Compliance Certification Services
47173 Benicia Street
Fremont, CA 94538
Tel: (510) 771-1000
Fax: (510) 661-0888

Data#: 14 File#: 115V.EMI Date: 12-20-2007 Time: 13:44:12

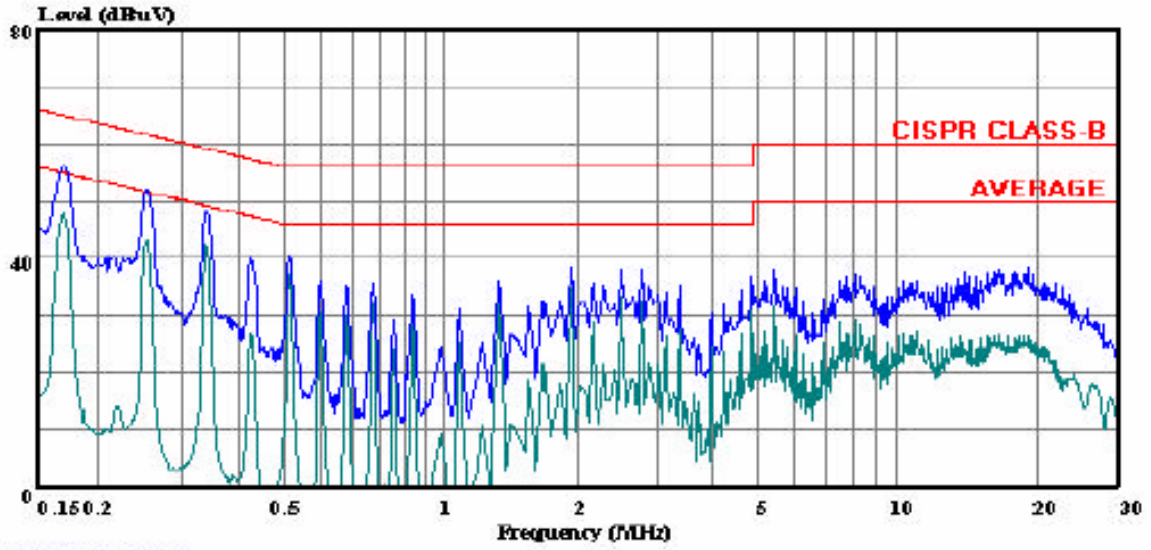

(Line Conduction)

Trace: 12

Ref Trace:

Condition: CISPR CLASS-B
Test Operator:: Vien Tran
Project #: : 07U11529
Company: : Broadcom
Configuration:: EUT & 3.9dBi antenna
Mode: : Normal
Target: : FCC Class B
Voltage: : 115VAC/60Hz
: L2: Peak (Blue); Average (Green)

13. MAXIMUM PERMISSIBLE EXPOSURE

FCC RULES

§1.1310 The criteria listed in Table 1 shall be used to evaluate the environmental impact of human exposure to radio-frequency (RF) radiation as specified in §1.1307(b), except in the case of portable devices which shall be evaluated according to the provisions of §2.1093 of this chapter.

TABLE 1—LIMITS FOR MAXIMUM PERMISSIBLE EXPOSURE (MPE)

Frequency range (MHz)	Electric field strength (V/m)	Magnetic field strength (A/m)	Power density (mW/cm ²)	Averaging time (minutes)
(A) Limits for Occupational/Controlled Exposures				
0.3–3.0	614	1.63	*(100)	6
3.0–30	1842/f	4.89/f	*(900/f ²)	6
30–300	61.4	0.163	1.0	6
300–1500	f/300	6
1500–100,000	5	6
(B) Limits for General Population/Uncontrolled Exposure				
0.3–1.34	614	1.63	*(100)	30
1.34–30	824/f	2.19/f	*(180/f ²)	30

IC RULES

IC Safety Code 6, Section 2.2.1 (a) A person other than an RF and microwave exposed worker shall not be exposed to electromagnetic radiation in a frequency band listed in Column 1 of Table 5, if the field strength exceeds the value given in Column 2 or 3 of Table 5, when averaged spatially and over time, or if the power density exceeds the value given in Column 4 of Table 5, when averaged spatially and over time.

TABLE 1—LIMITS FOR MAXIMUM PERMISSIBLE EXPOSURE (MPE)—Continued

Frequency range (MHz)	Electric field strength (V/m)	Magnetic field strength (A/m)	Power density (mW/cm ²)	Averaging time (minutes)
30–300	27.5	0.073	0.2	30
300–1500	f/1500	30
1500–100,000	1.0	30

f = frequency in MHz

* = Plane-wave equivalent power density

NOTE 1 TO TABLE 1: Occupational/controlled limits apply in situations in which persons are exposed as a consequence of their employment provided those persons are fully aware of the potential for exposure and can exercise control over their exposure. Limits for occupational/controlled exposure also apply in situations when an individual is transient through a location where occupational/controlled limits apply provided he or she is made aware of the potential for exposure.

NOTE 2 TO TABLE 1: General population/uncontrolled exposures apply in situations in which the general public may be exposed, or in which persons that are exposed as a consequence of their employment may not be fully aware of the potential for exposure or can not exercise control over their exposure.

Table 5
Exposure Limits for Persons Not Classed As RF and Microwave Ex-
posed Workers (Including the General Public)

1 Frequency (MHz)	2 Electric Field Strength; rms (V/m)	3 Magnetic Field Strength; rms (A/m)	4 Power Density (W/m ²)	5 Averaging Time (min)
0.003–1	280	2.19		6
1–10	280/ <i>f</i>	2.19/ <i>f</i>		6
10–30	28	2.19/ <i>f</i>		6
30–300	28	0.073	2*	6
300–1 500	1.585 <i>f</i> ^{0.5}	0.0042 <i>f</i> ^{0.5}	<i>f</i> /150	6
1 500–15 000	61.4	0.163	10	6
15 000–150 000	61.4	0.163	10	616 000 / <i>f</i> ^{1.2}
150 000–300 000	0.158 <i>f</i> ^{0.5}	4.21 x 10 ⁻⁴ <i>f</i> ^{0.5}	6.67 x 10 ⁻⁵ <i>f</i>	616 000 / <i>f</i> ^{1.2}

* Power density limit is applicable at frequencies greater than 100 MHz.

- Notes:**
1. Frequency, *f*, is in MHz.
 2. A power density of 10 W/m² is equivalent to 1 mW/cm².
 3. A magnetic field strength of 1 A/m corresponds to 1.257 microtesla (μT) or 12.57 milligauss (mG).

CALCULATIONS

Given

$$E = \sqrt{(30 * P * G) / d}$$

and

$$S = E^2 / 3770$$

where

E = Field Strength in Volts/meter

P = Power in Watts

G = Numeric antenna gain

d = Distance in meters

S = Power Density in milliwatts/square centimeter

Combining equations, rearranging the terms to express the distance as a function of the remaining variables, changing to units of Power to mW and Distance to cm, and substituting the logarithmic form of power and gain yields:

$$d = 0.282 * 10^{((P + G) / 20)} / \sqrt{S}$$

where

d = MPE distance in cm

P = Power in dBm

G = Antenna Gain in dBi

S = Power Density Limit in mW/cm²

Rearranging terms to calculate the power density at a specific distance yields

$$S = 0.0795 * 10^{((P + G) / 10)} / (d^2)$$

The power density in units of mW/cm² is converted to units of W/m² by multiplying by a factor of 10.

LIMITS

From FCC §1.1310 Table 1 (B), the maximum value of $S = 1.0 \text{ mW/cm}^2$

From IC Safety Code 6, Section 2.2 Table 5 Column 4, $S = 10 \text{ W/m}^2$

RESULTS

(MPE distance equals 20 cm)

Mode	Band	MPE Distance (cm)	Output Power (dBm)	Antenna Gain (dBi)	FCC Power Density (mW/cm ²)	IC Power Density (W/m ²)
WLAN	5 GHz	20.0	21.87	7.21	0.16	1.61