

Nemko Test Report: 126984-1TRFWL

Applicant: DAP Technologies
875 Charest Boulevard West,
suite 200,
Québec City, QC, Canada
G1N 2C9

Apparatus: Handheld computer 8900K series

FCC ID: T5M8900K2

In Accordance With: FCC Part 15 Subpart C, 15.247
FHSS System and Digitally Modulated Radiators
902–928 MHz, 2400–2483.5 MHz, 5725–5850 MHz

Authorized By: 
Kevin Ma, Wireless/EMC Specialist

Date: November 11, 2009

Total Number of Pages: 19

TABLE OF CONTENTS

Section 1 : Report Summary	3
Section 2 : Equipment Under Test.....	4
2.1 Identification of Equipment Under Test (EUT).....	4
2.2 Accessories	4
2.3 EUT Description.....	4
2.4 Technical Specifications of the EUT	5
2.5 EUT Setup diagram	5
2.6 Operation of the EUT during testing	5
2.7 Modifications incorporated in the EUT	5
Section 3 : Test Conditions.....	6
3.1 Specifications	6
3.2 Deviations From Laboratory Test Procedures	6
3.3 Test Environment	6
3.4 Measurement Uncertainty.....	6
3.5 Test Equipment.....	6
Section 4 : Results Summary	7
4.1 FCC Part 15 Subpart C : Test Results	7
Appendix A : Test Results.....	8
Clause 15.207(a) Powerline Conducted Emissions	8
Clause 15.209(a) Radiated Emissions within Restricted Bands	10
Clause 15.247(b)(3) Maximum peak output power of systems using digital modulation in the 902–928 MHz, 2400–2483.5 MHz and 5725–5850 MHz bands.....	14
Clause 15.247(b)(4) Maximum peak output power	14
Clause 15.247(d) Spurious Emissions Not in Restricted Bands	16
Appendix B : Setup Photographs	18
Appendix C : Block Diagram of Test Setups.....	19

Section 1 : Report Summary

These tests were conducted on a sample of the equipment for the purpose of demonstrating compliance with Part 15, Subpart C. Radiated tests were conducted in accordance with ANSI C63.4-2003.

The assessment summary is as follows:

Apparatus Assessed:	Handheld computer 8900K series
Specification:	FCC Part 15 Subpart C, 15.247 – Partial test
Compliance Status:	Complies
Exclusions:	None
Non-compliances:	None
Report Release History:	Original Release
Test Location:	Nemko Canada Inc. 303 River Road Ottawa, Ontario K1V 1H2
Registration Number:	176392 (3 m Semi-Anechoic Chamber)
Tests Performed By:	Andrey Adelberg, EMC/Wireless Specialist
Test Dates:	August–September 2009

Note that the results contained in this report relate only to the items tested and were obtained in the period between the date of initial receipt of samples and the date of issue of the report.

This test report has been completed in accordance with the requirements of ISO/IEC 17025. All results contain in this report are within Nemko Canada's ISO/IEC 17025 accreditation.

Nemko Canada Inc. authorizes the applicant to reproduce this report provided it is reproduced in its entirety and for use by the company's employees only.

Any use which a third party makes of this report, or any reliance on or decisions to be made based on it, are the responsibility of such third parties. Nemko Canada Inc. accepts no responsibility for damages, if any, suffered by any third party as a result of decisions made or actions based on this report.

Section 2 : Equipment Under Test

2.1 Identification of Equipment Under Test (EUT)

The following information identifies the EUT under test:

Type of Equipment:	Handheld computer 8900K series
Brand Name:	DAP, Kinysis
Model Number:	8900K2
Serial Number:	HN00007
Nemko Sample Number:	2
FCC ID:	T5M8900K2
Date of Receipt:	June 12, 2009

2.2 Accessories

The following information identifies accessories used to exercise the EUT during testing:

Description:	Docking station (Ethernet-USB host)
Brand Name:	DAP, Microflex
Model Name or Number:	CBCE840
Serial Number:	EH03401
Nemko Sample Number:	5
Connection Port:	Contact connection

Description:	AC adapter
Manufacturer:	Cincon Electronics Co., Ltd.
Model Name or Number:	TRG36A15
Serial Number:	36150-0000202
Nemko Sample Number:	10
Connection Port:	DC jack to the Ethernet-USB host

2.3 EUT Description

The EUT is a handheld computer with internal Bluetooth, GPRS and WiFi connectivity. The WiFi/BT and GPRS are restricted in software from operating simultaneously.

2.4 Technical Specifications of the EUT

Operating Band:	2400–2483.5 MHz
Operating Frequencies:	2412–2462 MHz
Modulation:	CCK; OFDM
Occupied Bandwidth:	10.1 MHz; 16.4 MHz
Channel Spacing:	20 MHz
Emission Designator:	G1D; W7D
Antenna Data:	Chip antenna 1 dBi
Power Supply Requirements:	120 VAC, 60 Hz

2.5 EUT Setup diagram

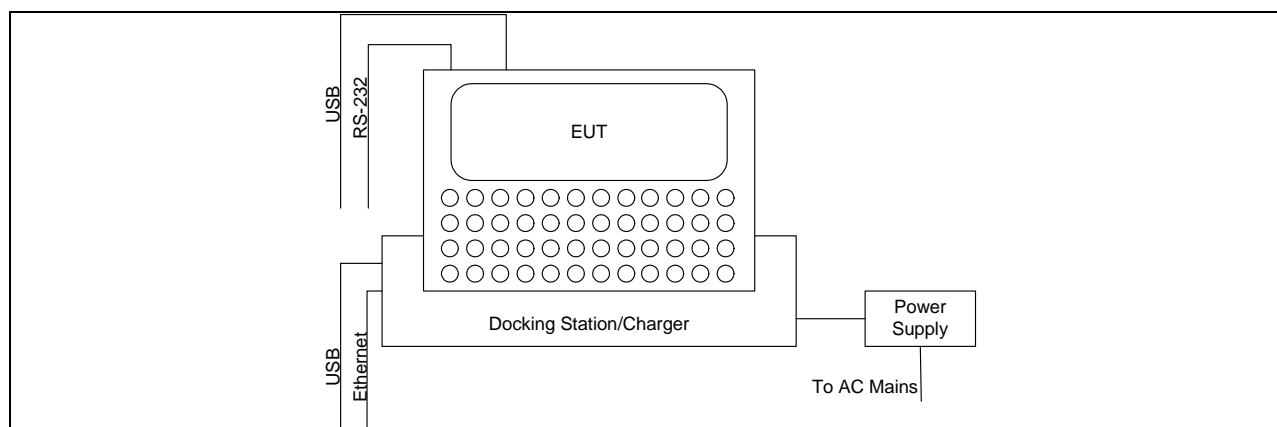

2.6 Operation of the EUT during testing

The EUT was operated using test software that would cause the EUT to transmit continuously.

2.7 Modifications incorporated in the EUT

There were no modifications performed to the EUT during this assessment.

Section 3 : Test Conditions

3.1 Specifications

The apparatus was assessed against the following specifications:

FCC Part 15 Subpart C, 15.247

FHSS System and Digitally Modulated Radiators
902–928 MHz, 2400–2483.5 MHz, 5725–5850 MHz

3.2 Deviations From Laboratory Test Procedures

No deviations were made from laboratory test procedures.

3.3 Test Environment

All tests were performed under the following environmental conditions:

Temperature range : 15–30 °C
Humidity range : 20–75 %
Pressure range : 86–106 kPa
Power supply range : ±5 % of rated voltages

3.4 Measurement Uncertainty

Nemko Canada measurement uncertainty has been calculated using guidance of UKAS LAB 34:2003 and TIA-603-B Nov 7, 2002. All calculations have been performed to provide a confidence level of 95 % and can be found in Nemko Canada document MU-003.

3.5 Test Equipment

Equipment	Manufacturer	Model No.	Asset/Serial No.	Cal. Date	Next Cal.
3 m EMI Test Chamber	TDK	SAC-3	FA002047	May 06/09	May 06/10
Receiver/Spectrum Analyzer	Rohde & Schwarz	ESU 26	FA002043	Dec. 16/08	Dec. 16/09
Bilog	Sunol	JB3	FA002108	Jan. 27/09	Jan. 27/10
Horn Antenna #2	EMCO	3115	FA000825	Jan. 21/09	Jan. 21/10
1 – 18 GHz Amplifier	JCA	JCA118-503	FA002091	Oct 2/08	Oct 2/09
LISN	Rohde & Schwarz	ENV216	FA002023	Sept. 08/09	Sept. 08/10
Horn 18 – 26.5 GHz	Electro-Metrics	SH-50/60-1	FA000479	COU	COU

COU – Calibrate on Use

NCR – No Calibration Required

Section 4 : Results Summary

This section contains the following:

FCC Part 15 Subpart C : Test Results

The column headed 'Required' indicates whether the associated clauses were invoked for the apparatus under test. The following abbreviations are used:

N No : not applicable / not relevant.

Y Yes : Mandatory i.e. the apparatus shall conform to these tests.

N/T Not Tested, mandatory but not assessed. (See Report Summary)

4.1 FCC Part 15 Subpart C : Test Results

Part 15	Test Description	Required	Result
15.31(e)	Variation of power supply	Y	PASS
15.207(a)	Powerline Conducted Emissions	Y	PASS
15.209(a)	Radiated Emissions within Restricted Bands	Y	PASS
15.247(a)(1)	Frequency hopping systems	N	
15.247(a)(1)(i)	Frequency hopping systems operating in the 902–928 MHz band	N	
15.247(a)(1)(ii)	Frequency hopping systems operating in the 5725–5850 MHz band	N	
15.247(a)(1)(iii)	Frequency hopping systems operating in the 2400–2483.5 MHz band	N	
15.247(a)(2)	Minimum 6 dB bandwidth	N/T*	
15.247(b)(1)	Maximum peak output power of Frequency hopping systems operating in the 2400–2483.5 MHz band and 5725–5850 MHz band	N	
15.247(b)(2)	Maximum peak output power of Frequency hopping systems operating in the 902–928 MHz band	N	
15.247(b)(3)	Maximum peak output power of systems using digital modulation in the 902–928 MHz, 2400–2483.5 MHz, and 5725–5850 MHz bands	Y	PASS
15.247(b)(4)	Maximum peak output power	Y	PASS
15.247(c)(1)	Fixed point-to-point Operation with directional antenna gains greater than 6 dBi	N	
15.247(c)(2)	Transmitters operating in the 2400–2483.5 MHz band that emit multiple directional beams	N	
15.247(d)	Radiated Emissions Not in Restricted Bands	Y	PASS
15.247(e)	Power Spectral Density for Digitally Modulated Devices	N/T*	
15.247(f)	Time of Occupancy for Hybrid Systems	N	

*-The EUT uses a pre-approved WiFi module. However the antennas are off the module therefore only partial tests were performed.



Appendix A : Test Results

Clause 15.207(a) Powerline Conducted Emissions

Frequency of Conducted limit (dB μ V)		
Emission (MHz)	Quasi-peak	Average
0.15–0.5	66 to 56*	56 to 46*
0.5–5	56	46
5–30	60	50

* Decreases with the logarithm of the frequency.

Test Results: Pass

Additional Observations:

All plots were obtained using a sweeping receiver with an IF of 9 kHz using a Peak and Average detector. The plots have been corrected with the cable loss and LISN loss to show compliance.

Phase

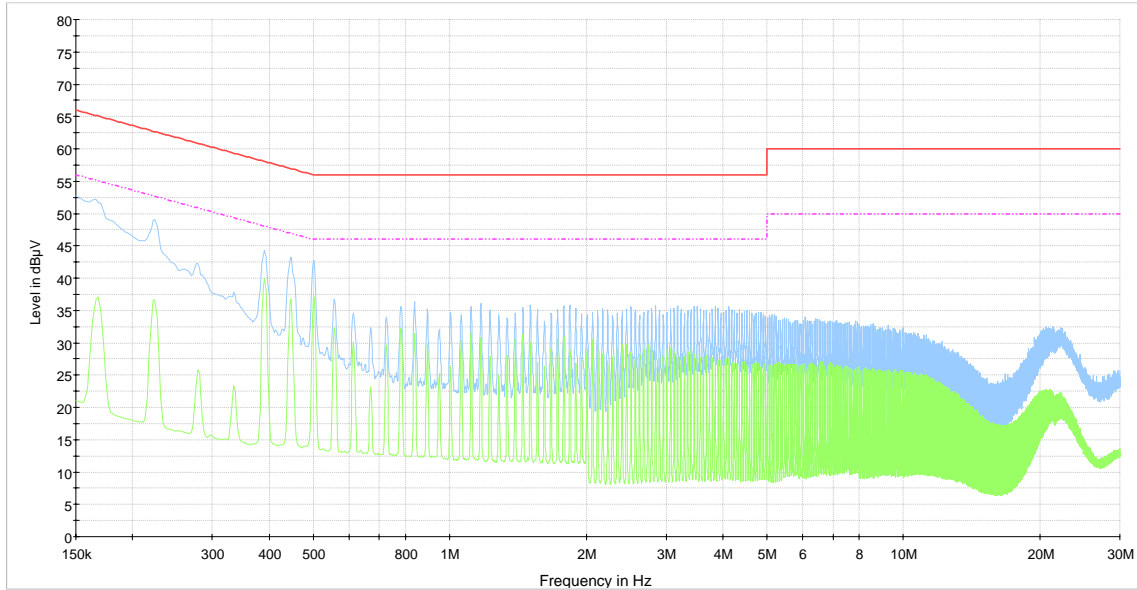

- 120VAC 60Hz Phase
- CISPR 22 Mains OP Class B Limit
- - - CISPR 22 Mains AV Class B Limit
- Preview Peak Detector
- Preview Average Detector

Neutral

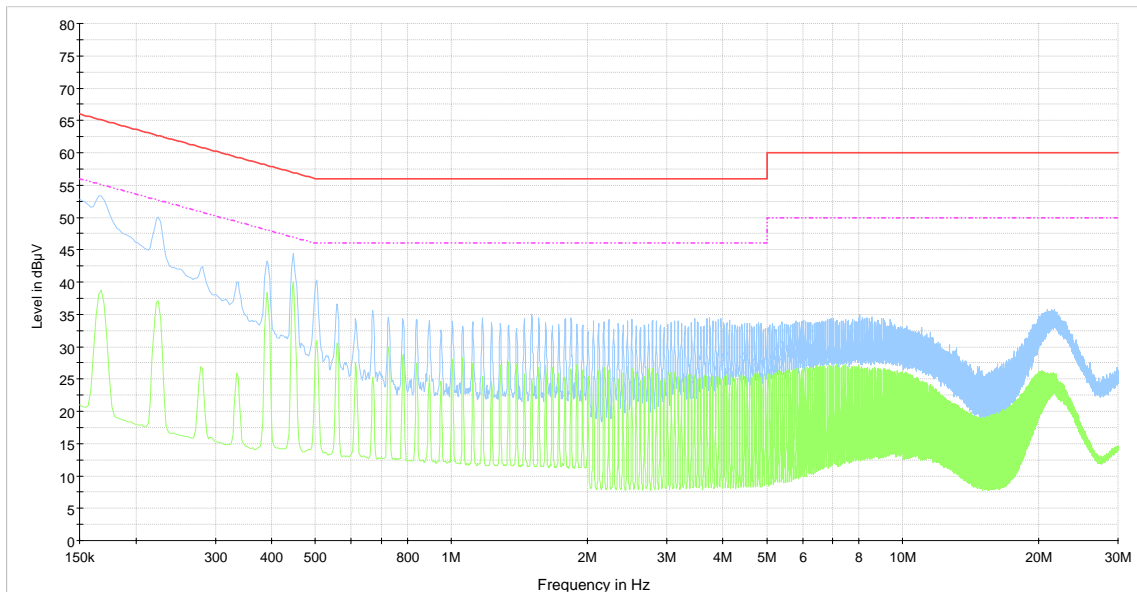

- 120VAC 60Hz Neutral
- CISPR 22 Mains OP Class B Limit
- - - CISPR 22 Mains AV Class B Limit
- Preview Peak Detector
- Preview Average Detector

Clause 15.209(a) Radiated Emissions within Restricted Bands

Except as provided elsewhere in this subpart, the emissions from an intentional radiator shall not exceed the field strength levels specified in the following table:

Frequency (MHz)	Field Strength		Measurement Distance (meters)
	(μ V/m)	(dB μ V/m)	
0.009–0.490	2400/F	67.6–20log(F)	300
0.490–1.705	24000/F	87.6–20log(F)	30
1.705–30.0	30	29.5	30
30–88	100	40.0	3
88–216	150	43.5	3
216–960	200	46.0	3
Above 960	500	54.0	3

Note: F = fundamental frequency in kHz

Test Results: Pass

Additional Observations:

These results apply to emissions found in the Restricted bands defined in FCC Part 15 Subpart C, 15.205.

The EUT was measured on three orthogonal axis.

The Emissions measured at a distance of 3 m and the spectrum was searched from 30 MHz to 25 GHz. Measurements were performed using a Peak detector with 1 MHz RBW / 1 MHz VBW for the Peak values and 1 MHz RBW / 10 Hz VBW for the Average values for the frequencies above 1 GHz. For the frequency below 1 GHz Quasi-Peak detector with 120 kHz RBW/300 kHz VBW was used.

Frequencies above 1 GHz:

Channel	Frequency, MHz	Pol.	Peak FS, dB μ V/m	Pk Limit, dB μ V/m	Pk Margin, dB
CCK modulation					
1	4824	H	52.17	74.00	21.83
1	4824	V	60.37	74.00	13.63
6	4872	H	56.10	74.00	17.90
6	4872	V	60.79	74.00	13.21
11	4924	H	56.92	74.00	17.08
11	4924	V	53.23	74.00	20.77
OFDM modulation					
1	4824	H	43.49	74.00	30.51
1	4824	V	51.69	74.00	22.31
6	4872	H	47.42	74.00	26.58
6	4872	V	52.11	74.00	21.89
11	4924	H	48.24	74.00	25.76
11	4924	V	44.55	74.00	29.45

Channel	Frequency, MHz	Pol.	Average FS, dB μ V/m	Avg Limit, dB μ V/m	Avg Margin, dB
CCK modulation					
1	4824	H	40.61	54.00	13.39
1	4824	V	48.81	54.00	5.19
6	4872	H	44.54	54.00	9.46
6	4872	V	49.23	54.00	4.77
11	4924	H	45.36	54.00	8.64
11	4924	V	41.67	54.00	12.33
OFDM modulation					
1	4824	H	31.93	54.00	22.07
1	4824	V	40.13	54.00	13.87
6	4872	H	35.86	54.00	18.14
6	4872	V	40.55	54.00	13.45
11	4924	H	36.68	54.00	17.32
11	4924	V	32.99	54.00	21.01

Note: Peak FS and Average FS values include antenna factor, cable losses and amplifier gain.

Frequencies below 1 GHz:

Frequency MHz	Quasi-Peak dB μ V/m	Polarity	Corr. dB	Margin dB	Limit dB μ V/m
124.890	32.9	V	15.4	10.6	43.5
166.620	37.6	V	13.5	5.9	43.5
168.270	36.7	V	13.5	6.8	43.5
169.230	34.7	V	13.4	8.8	43.5
999.690	47.3	H	26.6	6.7	54.0

Note: Correction factor includes antenna gain and cable loss.

**2.4835 GHz Band Edge
 CCK modulation:**

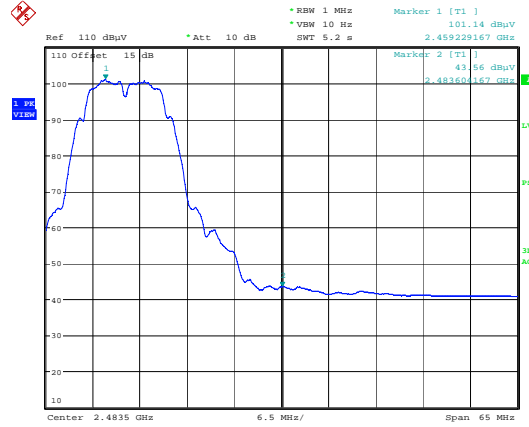
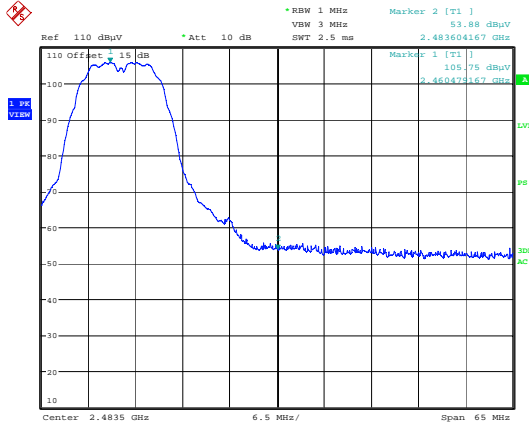

Date: 28.SEP.2009 14:51:43

Date: 28.SEP.2009 14:54:23

Frequency, MHz	Peak Field strength, dBμV/m	Limit, dBμV/m	Margin, dB
2483.5	53.88	74.00	20.12

Frequency, MHz	Average Field strength, dBμV/m	Limit, dBμV/m	Margin, dB
2483.5	43.56	54.00	10.44

**2.4835 GHz Band Edge
OFDM modulation:**

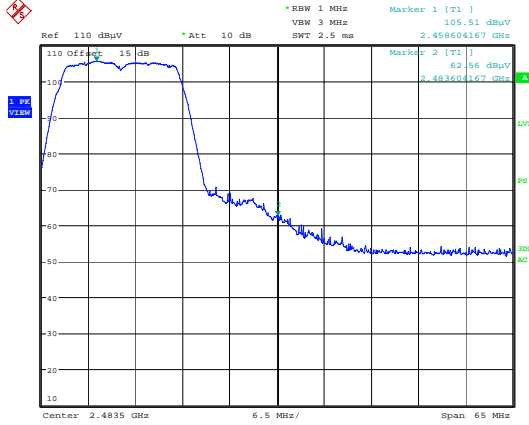

Date: 28.SEP.2009 14:45:24

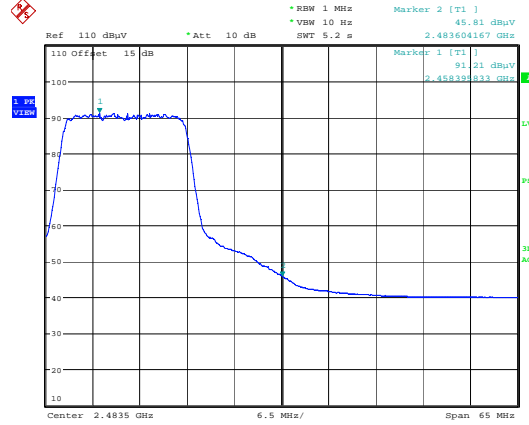

Date: 28.SEP.2009 14:44:15

Frequency, MHz	Peak Field strength, dB μ V/m	Limit, dB μ V/m	Margin, dB
2483.5	62.56	74.00	11.44

Frequency, MHz	Average Field strength, dB μ V/m	Limit, dB μ V/m	Margin, dB
2483.5	45.81	54.00	8.19

Clause 15.247(b)(3) Maximum peak output power of systems using digital modulation in the 902–928 MHz, 2400–2483.5 MHz and 5725–5850 MHz bands

For systems using digital modulation in the 902–928 MHz, 2400–2483.5 MHz, and 5725–5850 MHz bands: 1 W. As an alternative to a peak power measurement, compliance with the 1 W limit can be based on a measurement of the maximum conducted output power. Maximum Conducted Output Power is defined as the total transmit power delivered to all antennas and antenna elements averaged across all symbols in the signalling alphabet when the transmitter is operating at its maximum power control level. Power must be summed across all antennas and antenna elements. The average must not include any time intervals during which the transmitter is off or is transmitting at a reduced power level. If multiple modes of operation are possible (e.g., alternative modulation methods), the maximum conducted output power is the highest total transmit power occurring in any mode.

Clause 15.247(b)(4) Maximum peak output power

The conducted output power limit specified in paragraph (b) of this section is based on the use of antennas with directional gains that do not exceed 6 dBi. Except as shown in paragraph (c) of this section, if transmitting antennas of directional gain greater than 6 dBi are used, the conducted output power from the intentional radiator shall be reduced below the stated values in paragraphs (b)(1), (b)(2), and (b)(3) of this section, as appropriate, by the amount in dB that the directional gain of the antenna exceeds 6 dBi.

Test Results: Pass

Additional Observations:

The EUT was modified to perform the peak output power and average output power tests conducted.

Peak measurements were performed according to FCC DTS guidelines using power option 1, using spectrum analyzer with peak detector; the power was integrated across the emission band. RBW was used 100 kHz for CCK and 200 kHz for OFDM.

Average measurements were performed according to FCC DTS guidelines using method 3 of the power option 2.

The input voltage has been changed $\pm 15\%$ of nominal; no significant change in power reading was noticed.



Nemko Canada Inc.

Report Number: 126984-1TRFWL

Specification: FCC Part 15 Subpart C, 15.247

Peak Output Power:

Channel	Frequency MHz	Peak power dBm	Limit dBm	Margin dB
CCK modulation				
Low	2412	18.91	30.00	11.09
Mid	2437	18.44	30.00	11.56
High	2462	18.94	30.00	11.06
OFDM modulation				
Low	2412	18.41	30.00	11.59
Mid	2437	18.36	30.00	11.64
High	2462	18.33	30.00	11.67

Average Output Power:

Channel	Frequency MHz	Average power mW	Average power dBm	Limit dBm	Margin dB
CCK modulation					
Low	2412	33.113	15.20	30.00	14.80
Mid	2437	32.659	15.14	30.00	14.86
High	2462	37.239	15.71	30.00	14.29
OFDM modulation					
Low	2412	19.861	12.98	30.00	17.02
Mid	2437	19.231	12.84	30.00	17.16
High	2462	19.999	13.01	30.00	16.99

Sample plots:

Peak:

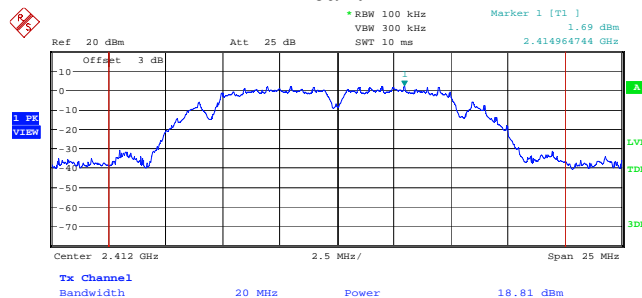

Average:

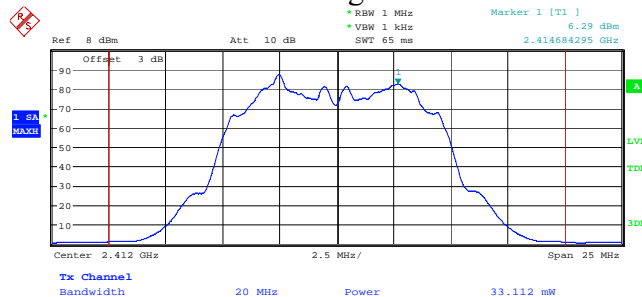

Clause 15.247(d) Spurious Emissions Not in Restricted Bands

In any 100 kHz bandwidth outside the frequency band in which the spread spectrum or digitally modulated intentional radiator is operating, the radio frequency power that is produced by the intentional radiator shall be at least 20 dB below that in the 100 kHz bandwidth within the band that contains the highest level of the desired power, based on either an RF conducted or a radiated measurement, provided the transmitter demonstrates compliance with the peak conducted power limits. If the transmitter complies with the conducted power limits based on the use of RMS averaging over a time interval, as permitted under paragraph (b)(3) of this section, the attenuation required under this paragraph shall be 30 dB instead of 20 dB. Attenuation below the general limits specified in §15.209(a) is not required. In addition, radiated emissions which fall in the restricted bands, as defined in §15.205(a), must also comply with the radiated emission limits specified in §15.209(a) (see §15.205(c)).

Test Results: Pass

Additional Observations:

The EUT was modified to perform the test conducted.

The spectrum was searched from 30 MHz to 25 GHz.
Measurements were performed using a Peak detector with 100 kHz RBW / 300 kHz VBW.

No emissions were detected higher than 30 dB below the in-band emission measured with 100 kHz IF bandwidth.



Nemko Canada Inc.

2.4 GHz Band Edge:

CCK modulation:

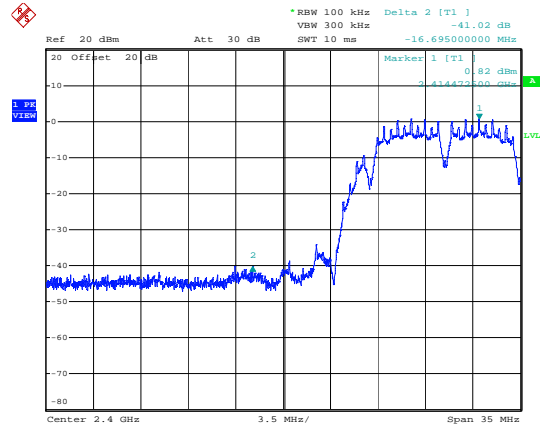

Date: 11.NOV.2009 08:39:57

OFDM modulation:

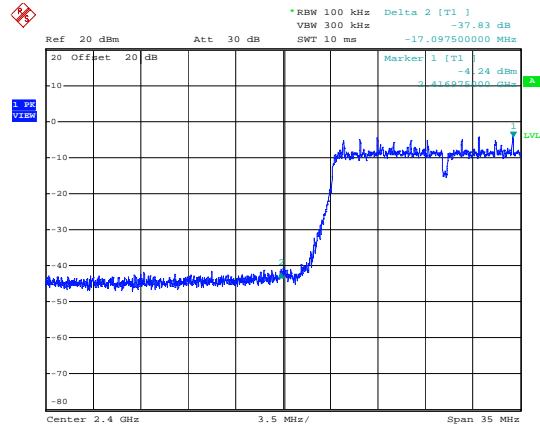

Date: 11.NOV.2009 08:41:44

Modulation	Band edge result, dBc/100 kHz	Limit, dBc/100 kHz	Margin, dB
CCK	-41.02	-30.00	11.02
OFDM	-37.83	-30.00	7.83

Appendix B : Setup Photographs

Conducted Emissions Setup:



Spurious Emissions Setup:

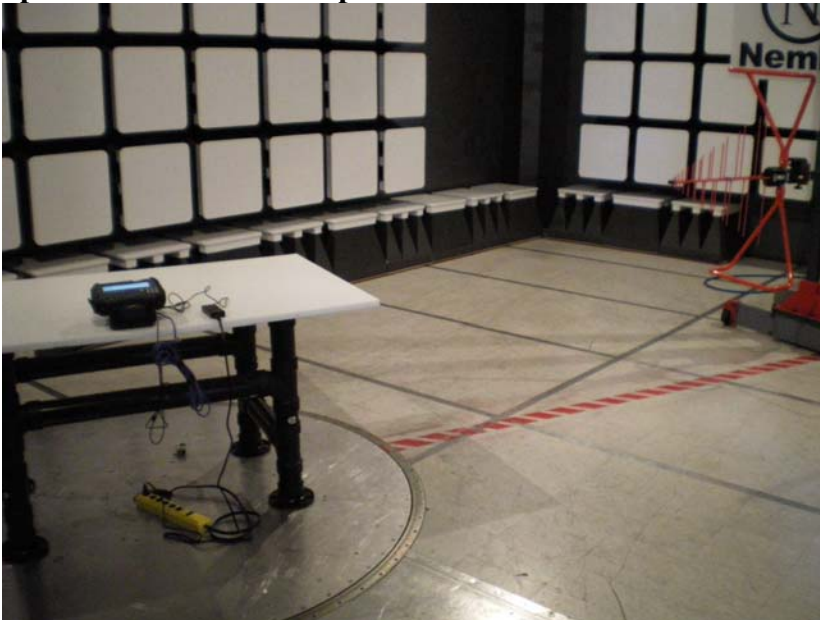

Appendix C : Block Diagram of Test Setups

Radiated Emissions above 30 MHz Test Site

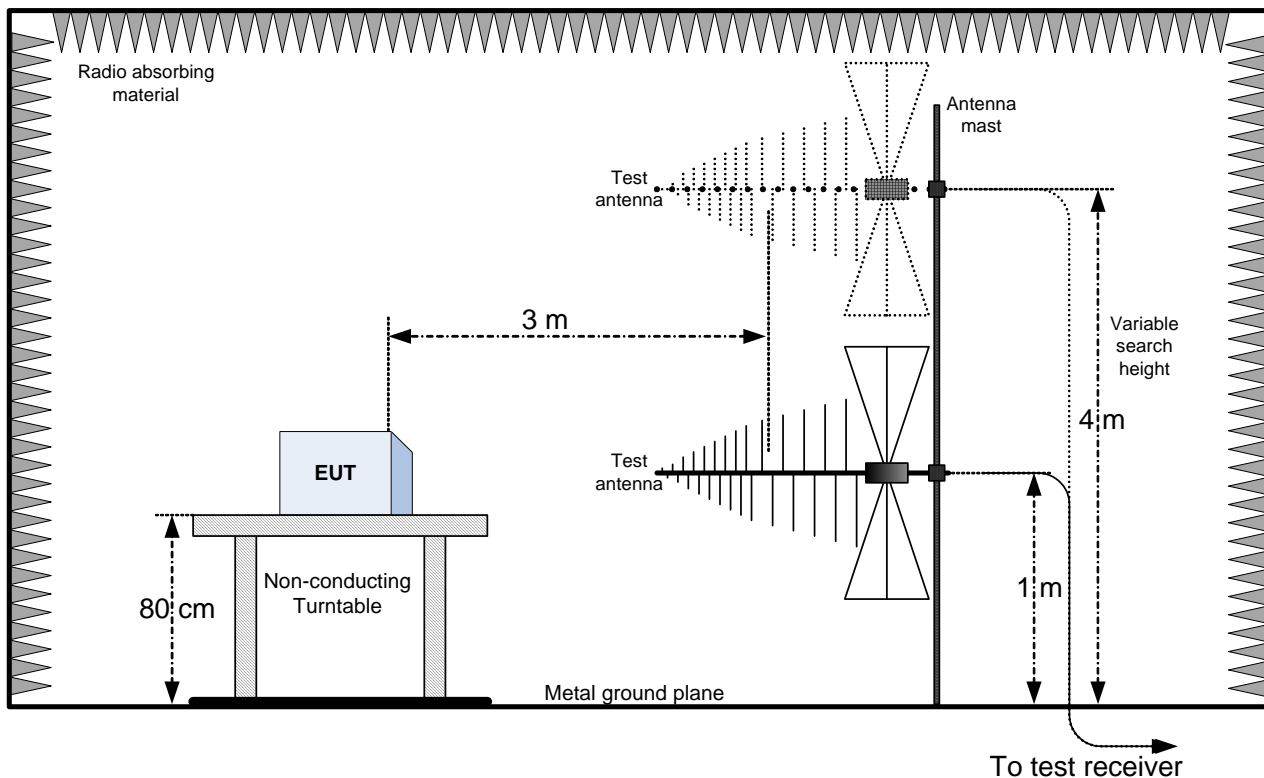

Conducted Emissions Test Site

