

Nemko Test Report: 126984-17TRFWL

Applicant: DAP Technologies
875 Charest Boulevard West,
suite 200,
Québec City, QC, Canada
G1N 2C9

Apparatus: Handheld computer 8900K series

FCC ID: T5M8900K1

In Accordance With: FCC Part 15 Subpart C, 15.247
FHSS System and Digitally Modulated Radiators
902–928 MHz, 2400–2483.5 MHz, 5725–5850 MHz

Authorized By:

Kevin Ma, Wireless/EMC Specialist

Date: November 24, 2009

Total Number of Pages: 23

TABLE OF CONTENTS

Section 1 : Report Summary	3
Section 2 : Equipment Under Test.....	4
2.1 Identification of Equipment Under Test (EUT).....	4
2.2 Accessories	4
2.3 EUT Description.....	4
2.4 Technical Specifications of the EUT	5
2.5 EUT Setup diagram	5
2.6 Operation of the EUT during testing	5
2.7 Modifications incorporated in the EUT	5
Section 3 : Test Conditions.....	6
3.1 Specifications	6
3.2 Deviations From Laboratory Test Procedures	6
3.3 Test Environment	6
3.4 Measurement Uncertainty.....	6
3.5 Test Equipment.....	6
Section 4 : Results Summary	7
4.1 FCC Part 15 Subpart C : Test Results	7
Appendix A : Test Results.....	8
Clause 15.207(a) Powerline Conducted Emissions	8
Clause 15.209(a) Radiated Emissions within Restricted Bands	10
Clause 15.247(a)(1) Frequency hopping systems	14
Clause 15.247(a)(1)(iii) Frequency hopping systems operating in the 2400–2483.5 MHz band	17
Clause 15.247(b)(1) Maximum peak output power of Frequency hopping systems operating in the 2400–2483.5 MHz band and 5725–5850 MHz band	19
Clause 15.247(b)(4) Maximum peak output power	19
Clause 15.247(d) Radiated Emissions Not in Restricted Bands	20
Appendix B : Setup Photographs	22
Appendix C : Block Diagram of Test Setups.....	23

Section 1 : Report Summary

These tests were conducted on a sample of the equipment for the purpose of demonstrating compliance with Part 15, Subpart C. Radiated tests were conducted in accordance with ANSI C63.4-2003.

The assessment summary is as follows:

Apparatus Assessed:	Handheld computer 8900K series
Specification:	FCC Part 15 Subpart C, 15.247
Compliance Status:	Complies
Exclusions:	None
Non-compliances:	None
Report Release History:	Original Release
Test Location:	Nemko Canada Inc. 303 River Road Ottawa, Ontario K1V 1H2
Registration Number:	176392 (3 m Semi-Anechoic Chamber)
Tests Performed By:	Andrey Adelberg, EMC/Wireless Specialist
Test Dates:	September–August, 2009

Note that the results contained in this report relate only to the items tested and were obtained in the period between the date of initial receipt of samples and the date of issue of the report.

This test report has been completed in accordance with the requirements of ISO/IEC 17025. All results contain in this report are within Nemko Canada's ISO/IEC 17025 accreditation.

Nemko Canada Inc. authorizes the applicant to reproduce this report provided it is reproduced in its entirety and for use by the company's employees only.

Any use which a third party makes of this report, or any reliance on or decisions to be made based on it, are the responsibility of such third parties. Nemko Canada Inc. accepts no responsibility for damages, if any, suffered by any third party as a result of decisions made or actions based on this report.

Section 2 : Equipment Under Test

2.1 Identification of Equipment Under Test (EUT)

The following information identifies the EUT under test:

Type of Equipment:	Handheld computer 8900K series
Brand Name:	DAP, Kinsys
Model Number:	8900K1
Serial Number:	HN00007
Nemko Sample Number:	2
FCC ID:	T5M8900K1
Date of Receipt:	June 12, 2009

2.2 Accessories

The following information identifies accessories used to exercise the EUT during testing:

Description:	Docking station (Ethernet-USB host)
Brand Name:	DAP, Microflex
Model Name or Number:	CBCE840
Serial Number:	EH03401
Nemko Sample Number:	5
Connection Port:	Contact connection

Description:	AC adapter
Manufacturer:	Cincon Electronics Co., Ltd.
Model Name or Number:	TRG36A15
Serial Number:	36150-0000202
Nemko Sample Number:	10
Connection Port:	DC jack to the Ethernet-USB host

2.3 EUT Description

The EUT is a handheld computer with internal Bluetooth and WiFi connectivity.

2.4 Technical Specifications of the EUT

Operating Band:	2400–2483.5 MHz
Operating Frequencies:	2402–2480 MHz
Modulation:	FHSS; GFSK
Emission Designator:	F1D
Antenna Data:	Chip antenna 1 dBi
Power Supply Requirements:	120 VAC, 60 Hz

2.5 EUT Setup diagram

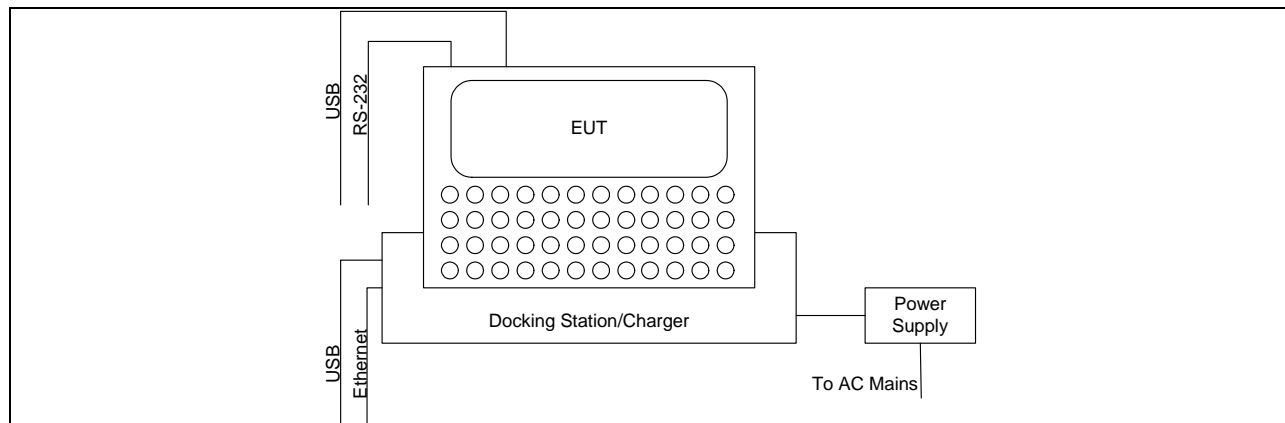

2.6 Operation of the EUT during testing

The EUT was operated using test software that would cause the EUT to transmit continuously on selected channels.

2.7 Modifications incorporated in the EUT

There were no modifications performed to the EUT during this assessment.

Section 3 : Test Conditions

3.1 Specifications

The apparatus was assessed against the following specifications:

FCC Part 15 Subpart C, 15.247

FHSS System and Digitally Modulated Radiators
902–928 MHz, 2400–2483.5 MHz and 5725–5850 MHz

3.2 Deviations From Laboratory Test Procedures

No deviations were made from laboratory test procedures.

3.3 Test Environment

All tests were performed under the following environmental conditions:

Temperature range : 15–30 °C
Humidity range : 20–75 %
Pressure range : 86–106 kPa
Power supply range : ±5 % of rated voltages

3.4 Measurement Uncertainty

Nemko Canada measurement uncertainty has been calculated using guidance of UKAS LAB 34:2003 and TIA-603-B Nov 7, 2002. All calculations have been performed to provide a confidence level of 95 % and can be found in Nemko Canada document MU-003.

3.5 Test Equipment

Equipment	Manufacturer	Model No.	Asset/Serial No.	Cal. Date	Next Cal.
3 m EMI Test Chamber	TDK	SAC-3	FA002047	May 06/09	May 06/10
Receiver/Spectrum Analyzer	Rohde & Schwarz	ESU 26	FA002043	Dec. 16/08	Dec. 16/09
Bilog	Sunol	JB3	FA002108	Jan. 27/09	Jan. 27/10
Horn Antenna #2	EMCO	3115	FA000825	Jan. 21/09	Jan. 21/10
1 – 18 GHz Amplifier	JCA	JCA118-503	FA002091	Oct 2/08	Oct 2/09
LISN	Rohde & Schwarz	ENV216	FA002023	Sept. 08/09	Sept. 08/10
Horn 18 – 26.5 GHz	Electro-Metrics	SH-50/60-1	FA000479	COU	COU

COU – Calibrate on Use

NCR – No Calibration Required

Section 4 : Results Summary

This section contains the following:

FCC Part 15 Subpart C : Test Results

The column headed 'Required' indicates whether the associated clauses were invoked for the apparatus under test. The following abbreviations are used:

- N No : not applicable / not relevant.
- Y Yes : Mandatory i.e. the apparatus shall conform to these tests.
- N/T Not Tested, mandatory but not assessed. (See Report Summary)

4.1 FCC Part 15 Subpart C : Test Results

Part 15	Test Description	Required	Result
15.31(e)	Variation of power supply	Y	PASS
15.207(a)	Powerline Conducted Emissions	Y	PASS
15.209(a)	Radiated Emissions within Restricted Bands	Y	PASS
15.247(a)(1)	Frequency hopping systems	Y	PASS
15.247(a)(1)(i)	Frequency hopping systems operating in the 902–928 MHz band	N	
15.247(a)(1)(ii)	Frequency hopping systems operating in the 5725–5850 MHz band	N	
15.247(a)(1)(iii)	Frequency hopping systems operating in the 2400–2483.5 MHz band	Y	PASS
15.247(a)(2)	Minimum 6 dB bandwidth	N	
15.247(b)(1)	Maximum peak output power of Frequency hopping systems operating in the 2400–2483.5 MHz band and 5725–5850 MHz band	Y	PASS
15.247(b)(2)	Maximum peak output power of Frequency hopping systems operating in the 902–928 MHz band	N	
15.247(b)(3)	Maximum peak output power of systems using digital modulation in the 902–928 MHz, 2400–2483.5 MHz, and 5725–5850 MHz bands	N	
15.247(b)(4)	Maximum peak output power	Y	PASS
15.247(c)(1)	Fixed point-to-point Operation with directional antenna gains greater than 6 dBi	N	
15.247(c)(2)	Transmitters operating in the 2400–2483.5 MHz band that emit multiple directional beams	N	
15.247(d)	Radiated Emissions Not in Restricted Bands	Y	PASS
15.247(e)	Power Spectral Density for Digitally Modulated Devices	N	
15.247(f)	Time of Occupancy for Hybrid Systems	N	



Appendix A : Test Results

Clause 15.207(a) Powerline Conducted Emissions

Frequency of Conducted limit (dB μ V)		
Emission (MHz)	Quasi-peak	Average
0.15–0.5	66 to 56*	56 to 46*
0.5–5	56	46
5–30	60	50

* Decreases with the logarithm of the frequency.

Test Results: Pass

Additional Observations:

All plots were obtained using a sweeping receiver with an IF of 9 kHz using a Peak and Average detector. The plots have been corrected with the cable loss and LISN loss to show compliance.

Phase

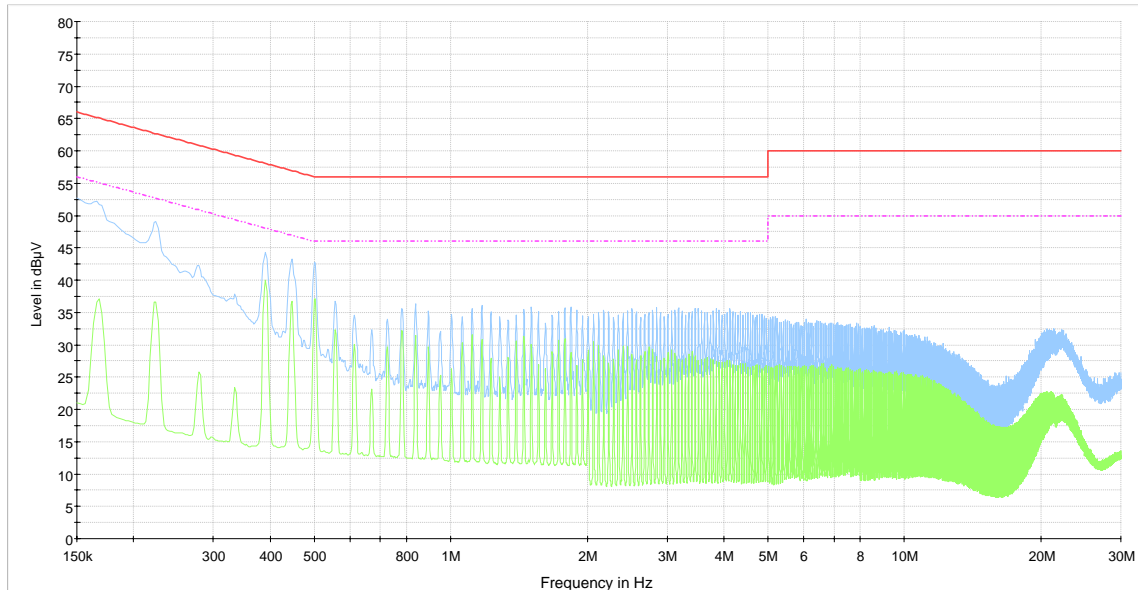

120VAC 60Hz Phase
 — CISPR 22 Mains QP Class B Limit
 - - - CISPR 22 Mains AV Class B Limit
 — Preview Peak Detector
 — Preview Average Detector

Neutral

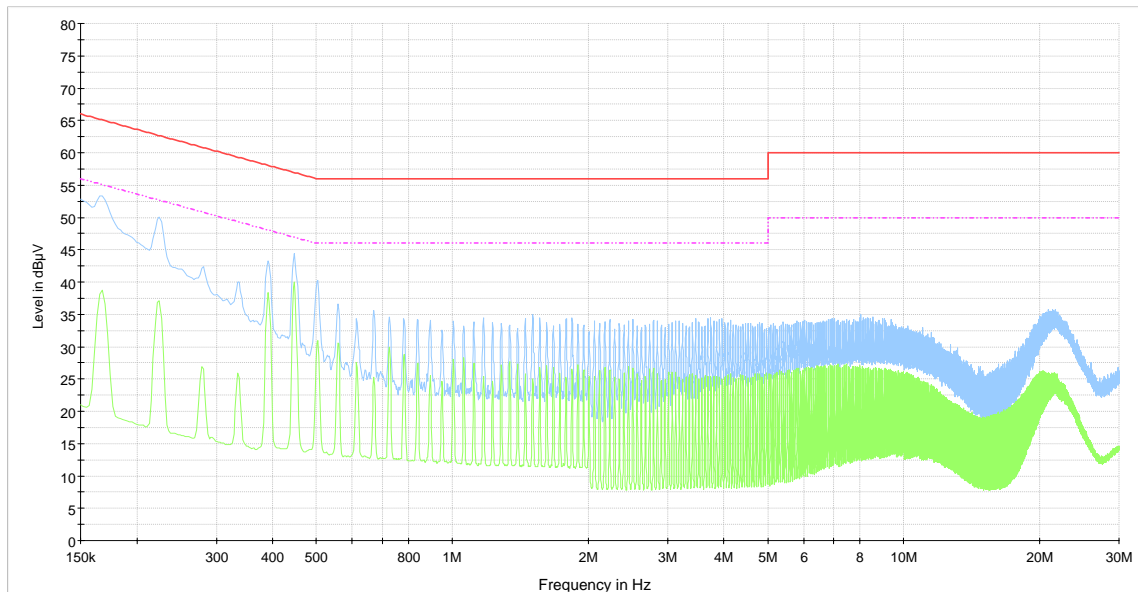

120VAC 60Hz Neutral
 — CISPR 22 Mains QP Class B Limit
 - - - CISPR 22 Mains AV Class B Limit
 — Preview Peak Detector
 — Preview Average Detector

Clause 15.209(a) Radiated Emissions within Restricted Bands

Except as provided elsewhere in this subpart, the emissions from an intentional radiator shall not exceed the field strength levels specified in the following table:

Frequency (MHz)	Field Strength		Measurement Distance (meters)
	($\mu\text{V/m}$)	($\text{dB}\mu\text{V/m}$)	
0.009–0.490	2400/F	67.6–20log(F)	300
0.490–1.705	24000/F	87.6–20log(F)	30
1.705–30.0	30	29.5	30
30–88	100	40.0	3
88–216	150	43.5	3
216–960	200	46.0	3
Above 960	500	54.0	3

Note: F = fundamental frequency in kHz

Test Results: Pass

Additional Observations:

These results apply to emissions found in the Restricted bands defined in FCC Part 15 Subpart C, 15.205.

The EUT was measured on three orthogonal axis.

The Emissions measured at a distance of 3 m and the spectrum was searched from 30 MHz to 25 GHz. Measurements were performed using a Peak detector with 1 MHz RBW / 1 MHz VBW for the Peak values.

For the frequency below 1 GHz Quasi-Peak detector with 120 kHz RBW/300 kHz VBW was used.

Frequencies above 1 GHz:

Channel	Frequency, MHz	Pol.	Peak FS, dB μ V/m	Pk Limit, dB μ V/m	Pk Margin, dB
1	4824	H	65.34	74.00	8.66
1	4824	V	69.10	74.00	4.90
6	4872	H	62.17	74.00	11.83
6	4872	V	69.77	74.00	4.23
11	4924	H	63.44	74.00	10.56
11	4924	V	63.07	74.00	10.93

Channel	Frequency, MHz	Pol.	Average FS, dB μ V/m	Avg Limit, dB μ V/m	Avg Margin, dB
1	4824	H	49.34	54.00	4.66
1	4824	V	53.10	54.00	0.90
6	4872	H	46.17	54.00	7.83
6	4872	V	53.77	54.00	0.23
11	4924	H	47.44	54.00	6.56
11	4924	V	47.07	54.00	6.93

Note: Peak FS values include antenna factor, cable losses and amplifier gain. Average FS is calculated from Peak FS plus the duty cycle factor (-16 dB)

Frequencies below 1 GHz:

Frequency MHz	Quasi-Peak dB μ V/m	Polarity	Corr. dB	Margin dB	Limit dB μ V/m
124.890	32.9	V	15.4	10.6	43.5
166.620	37.6	V	13.5	5.9	43.5
168.270	36.7	V	13.5	6.8	43.5
169.230	34.7	V	13.4	8.8	43.5
999.690	47.3	H	26.6	6.7	54.0

Note: Correction factor includes antenna gain and cable loss.

Delta Marker Measurement for 2.4835 GHz Band Edge

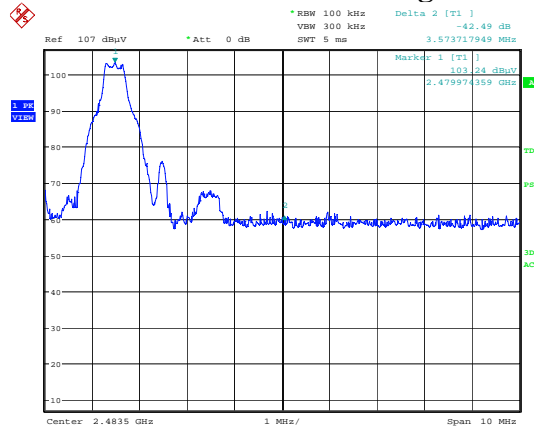

Date: 31.AUG.2009 16:12:48

Measured Field Strength for High Channel in 1 MHz RBW/3 MHz VBW = 107.65 dB μ V/m

Delta Marker = -42.43 dB

Therefore, Peak Field Strength = 107.65 dB μ V/m - 42.43 dB = 65.22 dB μ V/m

Limit = 74 dB μ V/m

Average Field Strength = 65.22 dB μ V/m - 16 dB (Duty cycle factor) = 49.22 dB μ V/m

Limit = 54 dB μ V/m

Upper Band Edge Hopping On:

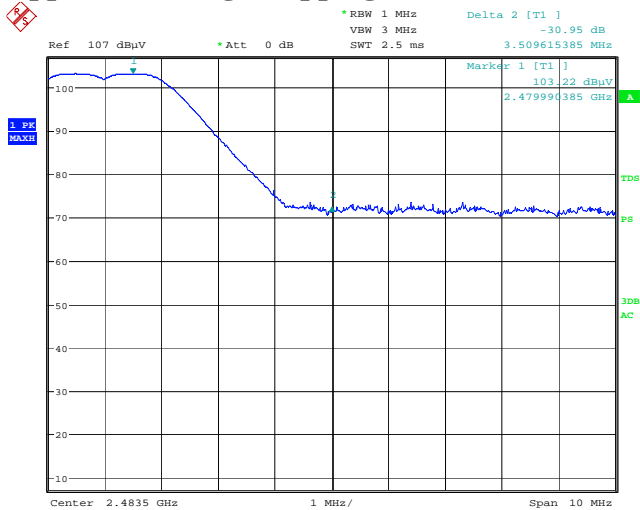

Date: 31.AUG.2009 16:19:03

Duty cycle correction factor calculation:
 Number of transmissions within 100 ms is 80

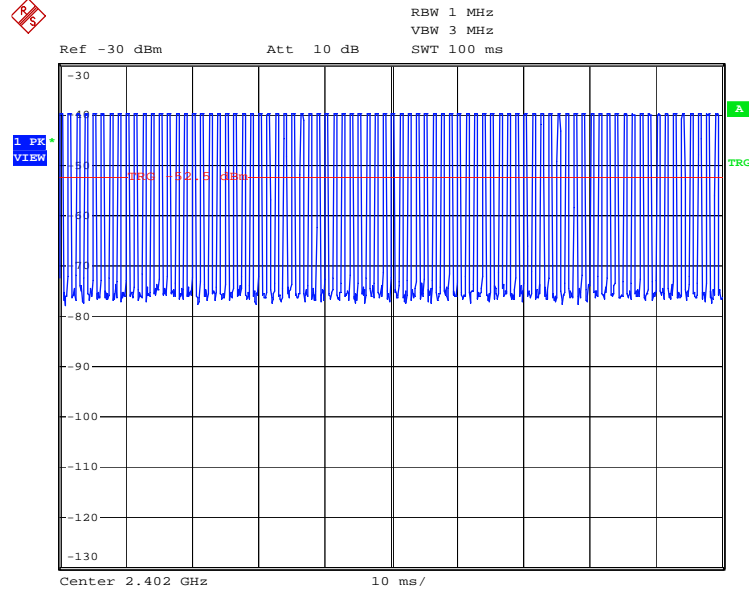

Date: 23.SEP.2009 09:36:57

Transmission width is 196 μs.

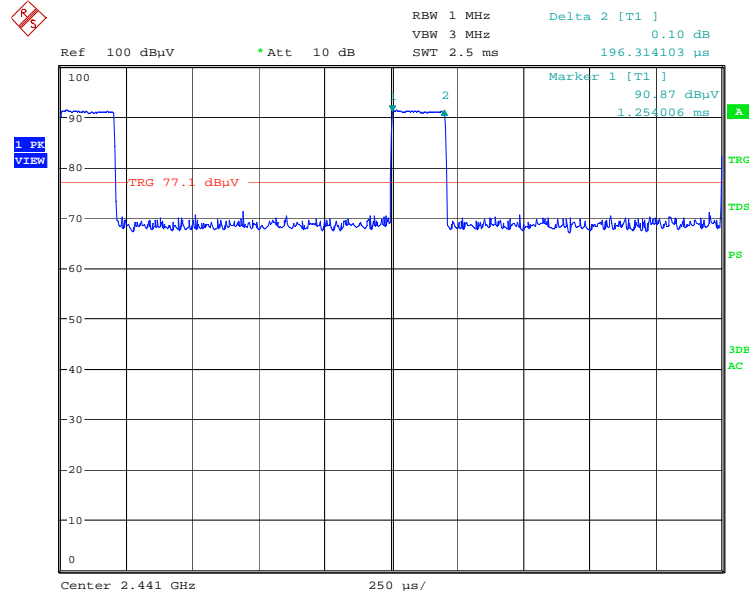

Date: 28.SEP.2009 11:34:18

Duty cycle factor calculation: $20 \times \text{Log} \{ (80 \times 0.196 \text{ ms}) / 100 \text{ ms} \} = -16.093 \sim -16 \text{ dB}$

Clause 15.247(a)(1) Frequency hopping systems

Frequency hopping systems shall have hopping channel carrier frequencies separated by a minimum of 25 kHz or the 20 dB bandwidth of the hopping channel, whichever is greater. Alternatively, frequency hopping systems operating in the 2400–2483.5 MHz band may have hopping channel carrier frequencies that are separated by 25 kHz or two-thirds of the 20 dB bandwidth of the hopping channel, whichever is greater, provided the systems operate with an output power no greater than 125 mW. The system shall hop to channel frequencies that are selected at the system hopping rate from a pseudo randomly ordered list of hopping frequencies. Each frequency must be used equally on the average by each transmitter. The system receivers shall have input bandwidths that match the hopping channel bandwidths of their corresponding transmitters and shall shift frequencies in synchronization with the transmitted signals.

Test Results: Pass

20 dB BW:

Frequency, MHz	20 dB bandwidth, MHz
2402	1.098
2441	1.088
2480	1.111

Channel separation is 1.005 MHz

Widest channel bandwidth was 1.111 MHz.

Two-thirds is 741 kHz

Channel separation, MHz	Minimum limit, MHz	Margin, MHz
1.005	0.741	0.264

Low channel

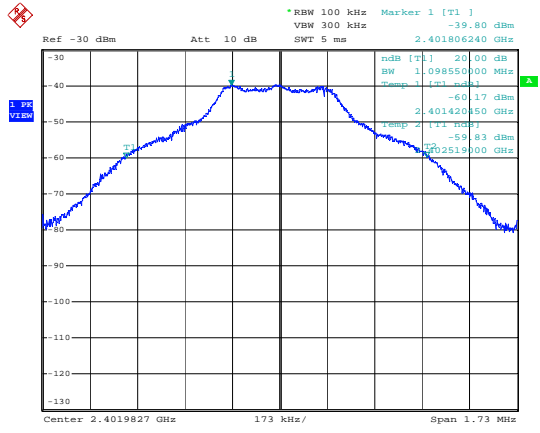

Date: 23.SEP.2009 09:44:16

Mid channel

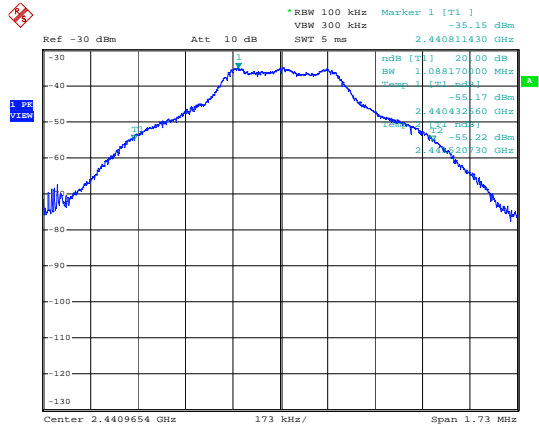

Date: 23.SEP.2009 09:42:43

High channel

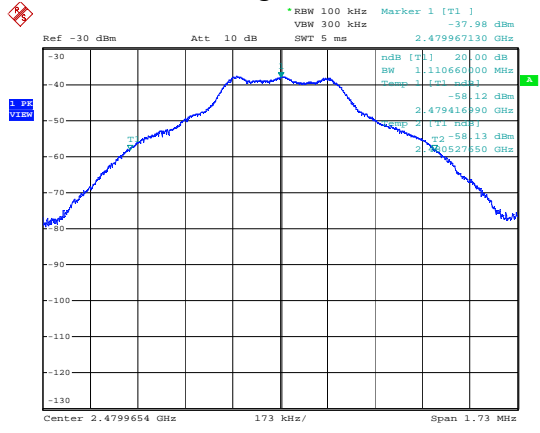

Date: 23.SEP.2009 09:43:21



Nemko Canada Inc.

Report Number: 126984-17TRFWL

Specification: FCC Part 15 Subpart C, 15.247

Channel separation:

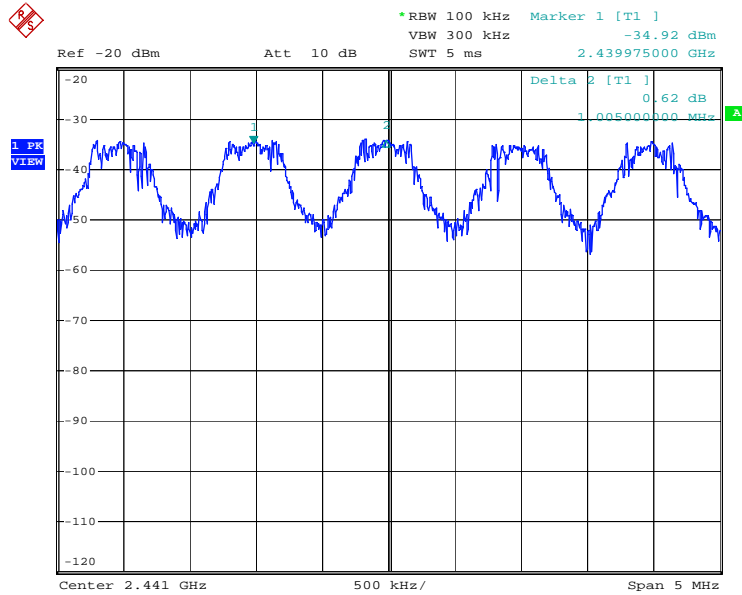

Date: 23.SEP.2009 09:26:15

Clause 15.247(a)(1)(iii) Frequency hopping systems operating in the 2400–2483.5 MHz band

Frequency hopping systems in the 2400–2483.5 MHz band shall use at least 15 channels. The average time of occupancy on any channel shall not be greater than 0.4 s within a period of 0.4 s multiplied by the number of hopping channels employed. Frequency hopping systems may avoid or suppress transmissions on a particular hopping frequency provided that a minimum of 15 channels are used

Test Results: Pass

Number of Hopping Channels:

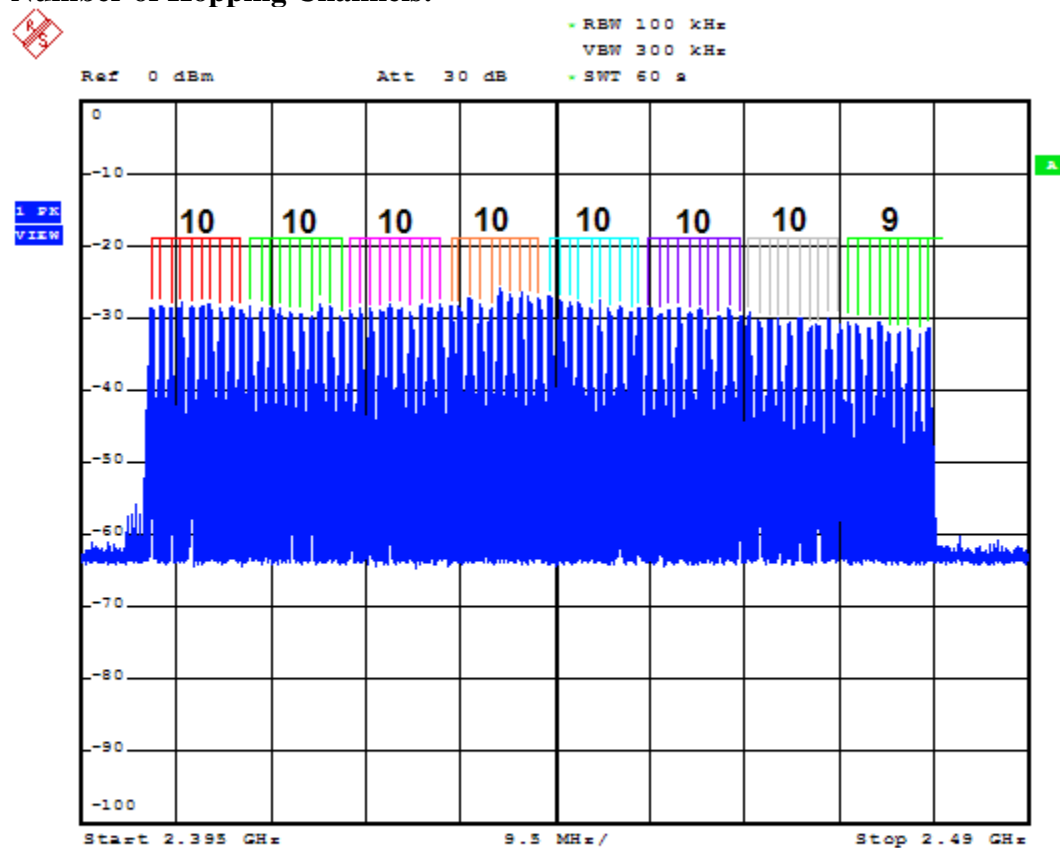

Date: 23.SEP.2009 09:18:24

Total number of hopping channels is 79

Time of Occupancy:

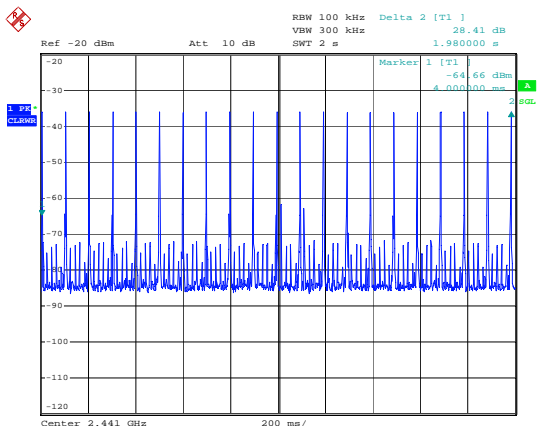

Date: 23.SEP.2009 09:28:51

Number of pulses within 2 s period is 21.

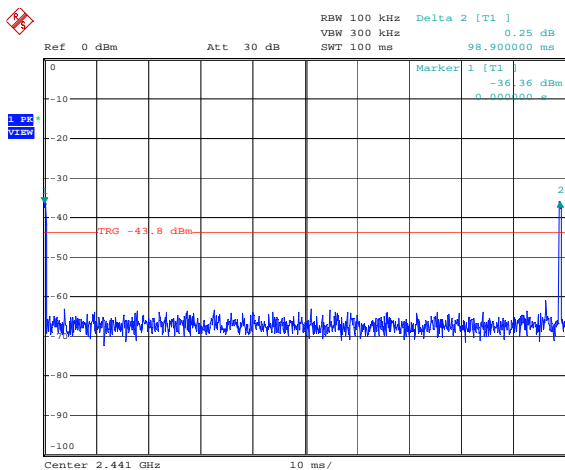

Pulse width 197 μs

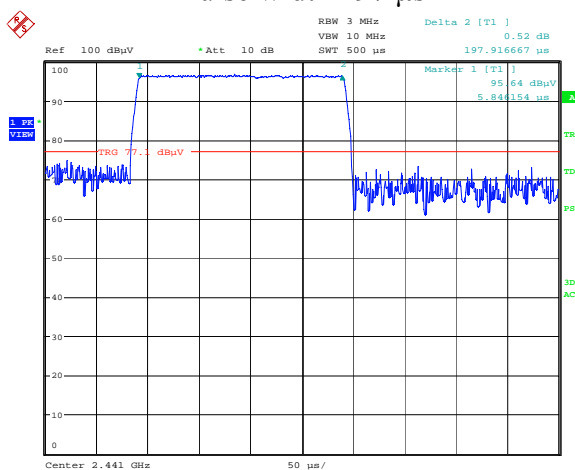

Occupancy Time

Limit:

0.4 seconds within a period of 0.4 s multiplied by the number of hopping channels employed, which is 0.4 s within the period of time $0.4 \times 79 = 31.6$ s

Measurement data:

Time of occupancy plots showing 21 hits per 2 s; therefore there would be $16 \times 21 = 336$ hits within 32 s

Total of Occupancy Time is therefore = $336 \times 0.197 \text{ ms} = 66.2 \text{ ms}$

Clause 15.247(b)(1) Maximum peak output power of Frequency hopping systems operating in the 2400–2483.5 MHz band and 5725–5850 MHz band

For frequency hopping systems operating in the 2400–2483.5 MHz band employing at least 75 non-overlapping hopping channels, and all frequency hopping systems in the 5725–5850 MHz band: 1 W. For all other frequency hopping systems in the 2400–2483.5 MHz band: 0.125 W.

Clause 15.247(b)(4) Maximum peak output power

The conducted output power limit specified in paragraph (b) of this section is based on the use of antennas with directional gains that do not exceed 6 dBi. Except as shown in paragraph (c) of this section, if transmitting antennas of directional gain greater than 6 dBi are used, the conducted output power from the intentional radiator shall be reduced below the stated values in paragraphs (b)(1), (b)(2), and (b)(3) of this section, as appropriate, by the amount in dB that the directional gain of the antenna exceeds 6 dBi.

Test Results: Pass

Peak Output Power:

Frequency MHz	POP mW	POP dBm	POP Limit dBm	Margin dB	Ag dBi	EIRP dBm	EIRP Limit dB	Margin dB
2402	17.79	12.50	30.00	17.50	1.00	13.50	36.00	22.50
2441	17.10	12.33	30.00	17.67	1.00	13.33	36.00	22.67
2480	21.52	13.33	30.00	16.67	1.00	14.33	36.00	21.67

Additional Observations:

All Measurements were performed conducted using a peak detector with 2 MHz/3 MHz RBW/VBW.

The input voltage has been changed $\pm 15\%$ of nominal; no significant change in power reading was noticed.

Clause 15.247(d) Radiated Emissions Not in Restricted Bands

In any 100 kHz bandwidth outside the frequency band in which the spread spectrum or digitally modulated intentional radiator is operating, the radio frequency power that is produced by the intentional radiator shall be at least 20 dB below that in the 100 kHz bandwidth within the band that contains the highest level of the desired power, based on either an RF conducted or a radiated measurement, provided the transmitter demonstrates compliance with the peak conducted power limits. If the transmitter complies with the conducted power limits based on the use of RMS averaging over a time interval, as permitted under paragraph (b)(3) of this section, the attenuation required under this paragraph shall be 30 dB instead of 20 dB. Attenuation below the general limits specified in §15.209(a) is not required. In addition, radiated emissions which fall in the restricted bands, as defined in §15.205(a), must also comply with the radiated emission limits specified in §15.209(a) (see §15.205(c)).

Test Results: Pass

Additional Observations:

The Emissions measured at a distance of 3 m and the spectrum was searched from 30 MHz to 25 GHz. Measurements were performed using a Peak detector with 100 kHz RBW / 300 kHz VBW.

The EUT was measured on three orthogonal axis.

No emissions were detected higher than 20 dB below the in-band emission measured with 100 kHz IF bandwidth.

Lower Band Edge Hopping On:

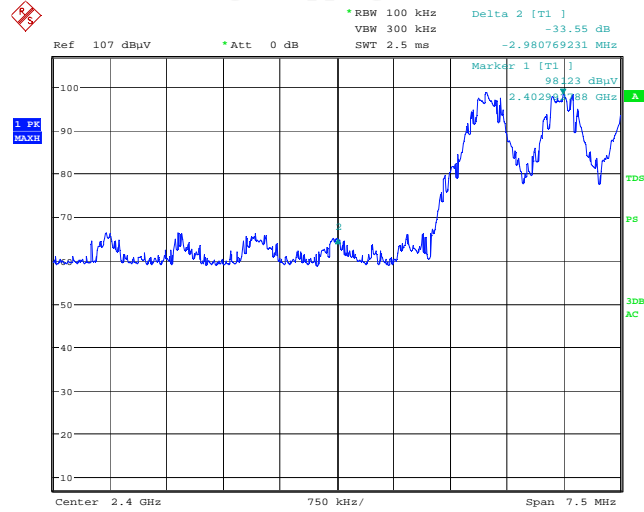

Date: 31.AUG.2009 16:20:51

Lower Band Edge Hopping Off:

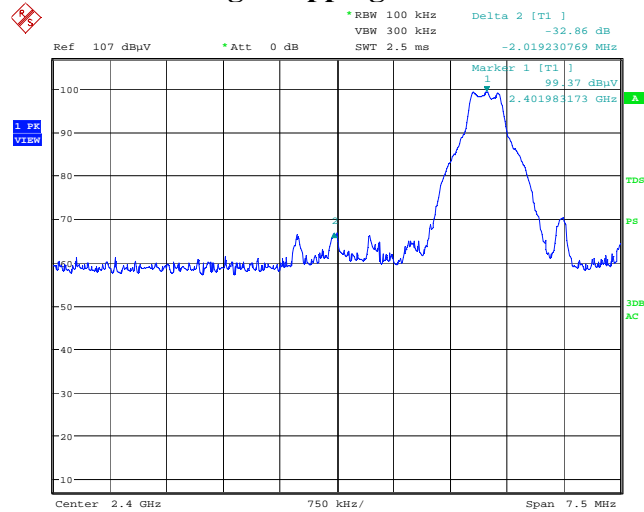

Date: 31.AUG.2009 16:23:07

Appendix B : Setup Photographs

Conducted Emissions Setup:



Spurious Emissions Setup:

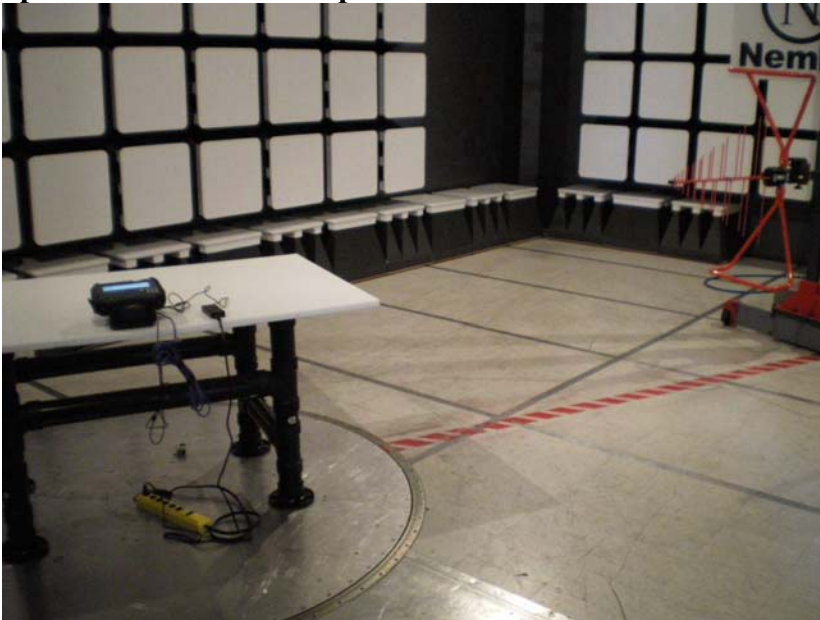

Appendix C : Block Diagram of Test Setups

Radiated Emissions above 30 MHz Test Site

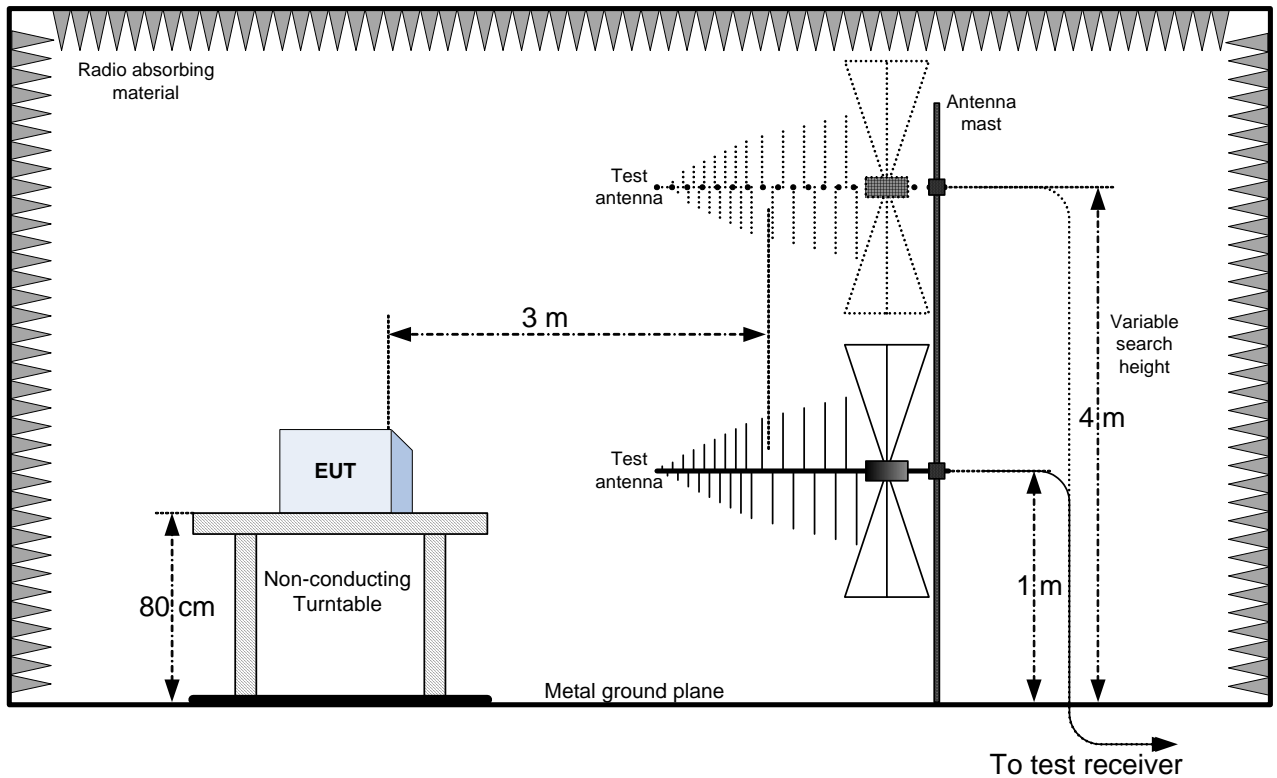

Conducted Emissions Test Site

