



FCC Radio Test Report

FCC ID: T58WF2471B

This report concerns (check one): Original Grant Class I Change

Issued Date : Dec. 05, 2012
Project No. : 1211C122
Equipment : Wireless Dual Band Router
Model Name : WF2471
Applicant : NETIS SYSTEMS CO., LTD
Address : 9F,B Block,Tsinghua Information Park, High-tech Industrial Park, Nanshan, Shenzhen, China
Manufacturer : Shenzhen Netcore Industrial Ltd.
Address : 9F,B Block,Tsinghua Information Park, High-tech Industrial Park, Nanshan, Shenzhen, China

Tested by:

Neutron Engineering Inc. EMC Laboratory

Date of Receipt: Nov. 20, 2012

Date of Test:

Nov. 20, 2012 ~ Dec. 04, 2012

Testing Engineer : David Mao
(David Mao)

Technical Manager : Leo Hung
(Leo Hung)

Authorized Signatory : Steven Lu
(Steven Lu)

Neutron Engineering Inc.

**No.3,Jinshagang 1st Road, ShiXia, Dalang
Town, Dong Guan, China.**

TEL : (0769) 8318-3000 FAX : (0769) 8319-6000



Declaration

Neutron represents to the client that testing is done in accordance with standard procedures as applicable and that test instruments used has been calibrated with the standards traceable to National Measurement Laboratory (**NML**) of **CHINA**, or National Institute of Standards and Technology (**NIST**) of **U.S.A.**

Neutron's reports apply only to the specific samples tested under conditions. It is manufacture's responsibility to ensure that additional production units of this model are manufactured with the identical electrical and mechanical components. **Neutron** shall have no liability for any declarations, inferences or generalizations drawn by the client or others from **Neutron** issued reports.

Neutron's reports must not be used by the client to claim product endorsement by the authorities or any agency of the Government.

This report is the confidential property of the client. As a mutual protection to the clients, the public and **Neutron-self**, extracts from the test report shall not be reproduced except in full with **Neutron's** authorized written approval.

Neutron's laboratory quality assurance procedures are in compliance with the **ISO Guide 17025** requirements, and accredited by the conformity assessment authorities listed in this test report.

Limitation

For the use of the authority's logo is limited unless the Test Standard(s)/Scope(s)/Item(s) mentioned in this test report is (are) included in the conformity assessment authorities acceptance respective.



Table of Contents	Page
1 . CERTIFICATION	5
2 . SUMMARY OF TEST RESULTS	6
2.1 TEST FACILITY	7
2.2 MEASUREMENT UNCERTAINTY	7
3 . GENERAL INFORMATION	8
3.1 GENERAL DESCRIPTION OF EUT	8
3.2 DESCRIPTION OF TEST MODES	10
3.3 TABLE OF PARAMETERS OF TEXT SOFTWARE SETTING	10
3.4 BLOCK DIGRAM SHOWING THE CONFIGURATION OF SYSTEM TESTED	11
3.5 DESCRIPTION OF SUPPORT UNITS	13
4 . EMC EMISSION TEST	14
4.1 CONDUCTED EMISSION MEASUREMENT	14
4.1.1 POWER LINE CONDUCTED EMISSION LIMITS	14
4.1.2 MEASUREMENT INSTRUMENTS LIST AND SETTING	14
4.1.3 TEST PROCEDURE	15
4.1.4 DEVIATION FROM TEST STANDARD	15
4.1.5 TEST SETUP	15
4.1.6 EUT OPERATING CONDITIONS	15
4.1.7 TEST RESULTS	16
4.2 RADIATED EMISSION MEASUREMENT	19
4.2.1 RADIATED EMISSION LIMITS	19
4.2.2 MEASUREMENT INSTRUMENTS LIST ANS SETTING	20
4.2.3 TEST PROCEDURE	21
4.2.4 DEVIATION FROM TEST STANDARD	21
4.2.5 TEST SETUP	22
4.2.6 EUT OPERATING CONDITIONS	22
4.2.7 TEST RESULTS (BETWEEN 30 – 1000 MHZ)	23
4.2.8 TEST RESULTS (ABOVE 1000 MHZ)	26
5 . BANDWIDTH TEST	58
5.1 APPLIED PROCEDURES / LIMIT	58
5.1.1 MEASUREMENT INSTRUMENTS LIST	58
5.1.2 TEST PROCEDURE	58
5.1.3 DEVIATION FROM STANDARD	58
5.1.4 TEST SETUP	58
5.1.5 EUT OPERATION CONDITIONS	58
5.1.6 TEST RESULTS	59
6 . MAXIMUM OUTPUT POWER TEST	69



Table of Contents	Page
6.1 APPLIED PROCEDURES / LIMIT	69
6.1.1 MEASUREMENT INSTRUMENTS LIST	69
6.1.2 TEST PROCEDURE	69
6.1.3 DEVIATION FROM STANDARD	69
6.1.4 TEST SETUP	69
6.1.5 EUT OPERATION CONDITIONS	69
6.1.6 TEST RESULTS	70
7 . ANTENNA CONDUCTED SPURIOUS EMISSION	73
7.1 APPLIED PROCEDURES / LIMIT	73
7.1.1 MEASUREMENT INSTRUMENTS LIST	73
7.1.2 TEST PROCEDURE	73
7.1.3 DEVIATION FROM STANDARD	73
7.1.4 TEST SETUP	73
7.1.5 EUT OPERATION CONDITIONS	73
7.1.6 TEST RESULTS	74
8 . POWER SPECTRAL DENSITY TEST	97
8.1 APPLIED PROCEDURES / LIMIT	97
8.1.1 MEASUREMENT INSTRUMENTS LIST	97
8.1.2 TEST PROCEDURE	97
8.1.3 DEVIATION FROM STANDARD	97
8.1.4 TEST SETUP	97
8.1.5 EUT OPERATION CONDITIONS	97
8.1.6 TEST RESULTS	98
9 . EUT TEST PHOTO	107



1. CERTIFICATION

Equipment : Wireless Dual Band Router
Brand Name : netis
Model Name : WF2471
Applicant : NETIS SYSTEMS CO., LTD
Factory : Dongguan City Netcore Network Technology Co.,Ltd.
Address : No.10-1,Sankeng Road,Qinghutou,Tangxia Town,Dongguan City
Date of Test : Nov. 20, 2012 ~ Dec. 04, 2012
Test Item : ENGINEERING SAMPLE
Standards : FCC Part15, Subpart C(15.247) / ANSI C63.4 : 2009

The above equipment has been tested and found compliance with the requirement of the relative standards by Neutron Engineering Inc. EMC Laboratory.

The test data, data evaluation, and equipment configuration contained in our test report (Ref No. NEI-FCCP-2-1211C122) were obtained utilizing the test procedures, test instruments, test sites that has been accredited by the Authority of NVLAP and TAF according to the ISO-17025 quality assessment standard and technical standard(s).

Test result included in this report is only for the 5745~5825MHz part of the product.



2. SUMMARY OF TEST RESULTS

FCC Part15 (15.247) , Subpart C				
Standard	Section	Test Item	Judgment	Remark
	15.207	Conducted Emission	PASS	
	15.247 (d)	Antenna conducted Spurious Emission	PASS	
	15.247 (a)(2)	6dB Bandwidth	PASS	
	15.247 (b)	Peak Output Power	PASS	
	15.247 (e)	Power Spectral Density	PASS	
	15.203	Antenna Requirement	PASS	
	15.247(d)	Transmitter Radiated Emissions FCC Limit: Table 15.209 RSS-210 Limit: Table 3	PASS	
	Note(1)	Receiver Radiated Emissions RSS-210 Limit: Table 3	-	N/A

Test procedures according to the technical standards:

NOTE:

- (1) "N/A" denotes test is not applicable in this test report
- (2) The test follows FCC KDB Publication No,558074(Measurement Guidelines of DTS)



2.1 TEST FACILITY

The test facilities used to collect the test data in this report is **DG-CB02/DG-C02** at the location of No.3, Jinshagang 1st Road, ShiXia, Dalang Town, Dong Guan, China.523792
 Neutron's test firm number is 319330

2.2 MEASUREMENT UNCERTAINTY

Where relevant, the following measurement uncertainty levels have been estimated for tests performed on the EUT as specified in CISPR 16-4-2:

The reported uncertainty of measurement $y \pm U$, where expanded uncertainty U is based on a standard uncertainty multiplied by a coverage factor of $k=2$, providing a level of confidence of approximately 95 %.

A. Conducted Measurement :

Test Site	Method	Measurement Frequency Range	U , (dB)	NOTE
DG-C02	CISPR	150 KHz ~ 30MHz	1.94	

B. Radiated Measurement :

Test Site	Method	Measurement Frequency Range	Ant. H / V	U,(dB)	NOTE
DG-CB03	CISPR	30MHz ~ 200MHz	V	3.82	
		30MHz ~ 200MHz	H	3.60	
		200MHz ~ 1,000MHz	V	3.86	
		200MHz ~ 1,000MHz	H	3.94	
		1GHz~18GHz	V	3.12	
		1GHz~18GHz	H	3.68	
		18GHz~40GHz	V	4.15	
		18GHz~40GHz	H	4.14	



3. GENERAL INFORMATION

3.1 GENERAL DESCRIPTION OF EUT

Equipment	Wireless Dual Band Router	
Brand Name	netis	
Model Name	WF2471	
Product Description	The EUT is a Wireless Dual Band Router.	
	Operation Frequency	5745~5825 MHz
	Modulation Type	802.11a/n:OFDM
	Bit Rate of Transmitter	300Mbps
	Number of Channel	5 CH, Please see note 2.(Page 10)
	Antenna Designation	Please see note 3.(Page 10)
	Antenna Gain(Peak)	
	Output Power	802.11a: 21.62 dBm 802.11n 20M: 19.92 dBm 802.11n 40M: 17.71 dBm
	Based on the application, features, or specification exhibited in User's Manual, the EUT is considered as an ITE/Computing Device. More details of EUT technical specification, please refer to the User's Manual.	
Power Source	DC voltage supplied from AC adapter. Model name: NT12V1AUL	
Power Rating	I/P AC 100-240V~ 0.3A 50/60Hz O/P DC 12V 1A	
Connecting I/O Port(s)	Please refer to the User's Manual	

Note:

1. For a more detailed features description, please refer to the manufacturer's specifications or the User's Manual.



2.

802.11a / 802.11n 20M					
Channel	Frequency (MHz)	Channel	Frequency (MHz)	Channel	Frequency (MHz)
149	5745	153	5765	157	5785
161	5805	165	5825		

802.11n 40M			
Channel	Frequency (MHz)	Channel	Frequency (MHz)
151	5755	159	5795

3. Antenna Specification:

Table for Filed Antenna

Ant.	Brand	Model Name	Antenna Type	Connector	Gain (dBi)	Note
1	Cortec	AN2400-92F19BO	Dipole	Mini	4.58	TX/RX
2	Cortec	AN2400-92F19BO	Dipole	Mini	4.58	TX/RX

Note: The EUT incorporates a MIMO function. Physically, the EUT provides two completed transmitters and two receivers (2T2R)

Operating Mode	1TX	2TX
	TX Mode	
802.11a	V (ANT1 or ANT2)	-
802.11n(20MHz)	-	V (ANT1 & ANT2)
802.11n(40MHz)	-	V (ANT1 & ANT2)



3.2 DESCRIPTION OF TEST MODES

To investigate the maximum EMI emission characteristics generates from EUT, the test system was pre-scanning tested base on the consideration of following EUT operation mode or test configuration mode which possible have effect on EMI emission level. Each of these EUT operation mode(s) or test configuration mode(s) mentioned above was evaluated respectively.

Pretest Mode	Description
Mode 1	TX A Mode CHANNEL 149/157/165
Mode 2	TX N20 Mode CHANNEL 149/157/165
Mode 3	TX N40 Mode CHANNEL 151/159
Mode 4	Normal Link

The EUT system operated these modes were found to be the worst case during the pre-scanning test as following:

For Conducted Test	
Final Test Mode	Description
Mode 4	Normal Link

For Radiated Test	
Final Test Mode	Description
Mode 1	TX A Mode CHANNEL 149/157/165
Mode 2	TX N20 Mode CHANNEL 149/157/165
Mode 3	TX N40 Mode CHANNEL 151/159

Note:

- (1) The measurements are performed at the high, middle, low available channels.

3.3 TABLE OF PARAMETERS OF TEXT SOFTWARE SETTING

During testing channel & power controlling software provided by the customer was used to control the operating channel as well as the output power level. The RF output power selection is for the setting of RF output power expected by the customer and is going to be fixed on the firmware of the final end product

Test software version	Cart		
Frequency	5745 MHz	5785 MHz	5825MHz
A Mode	58	57	59
N20M Mode	42	46	46

Test software version	Cart	
Frequency	5755 MHz	5795 MHz
N40M Mode	36	39



3.4 BLOCK DIGRAM SHOWING THE CONFIGURATION OF SYSTEM TESTED

Conducted Mode:

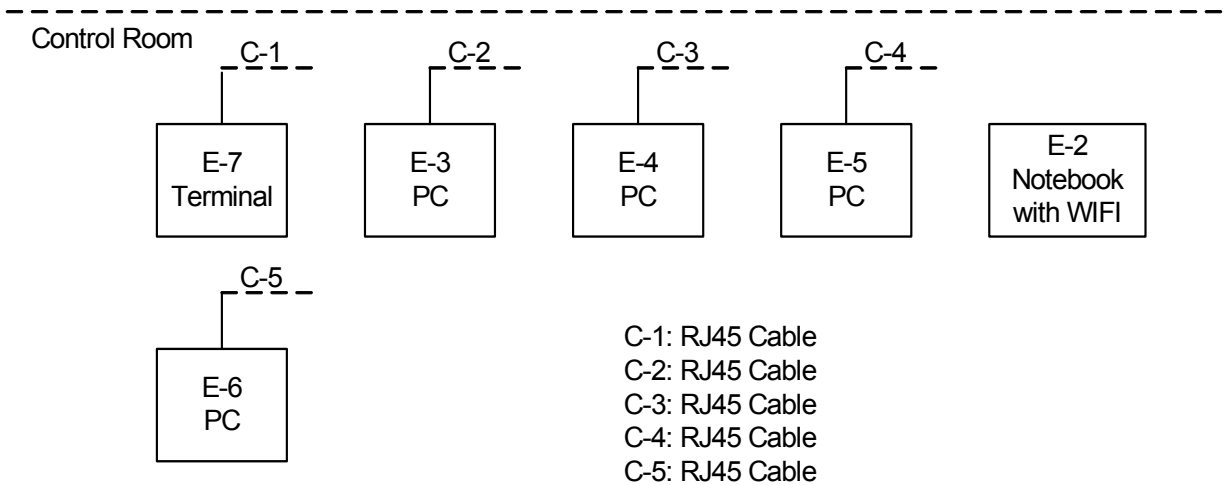
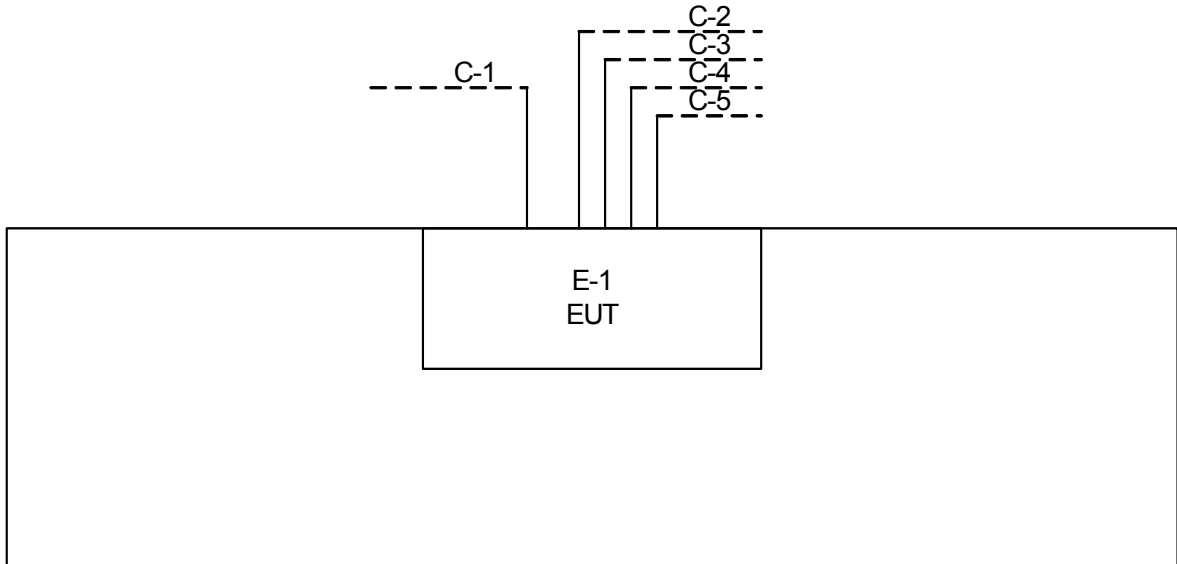



Radiated TX Mode:

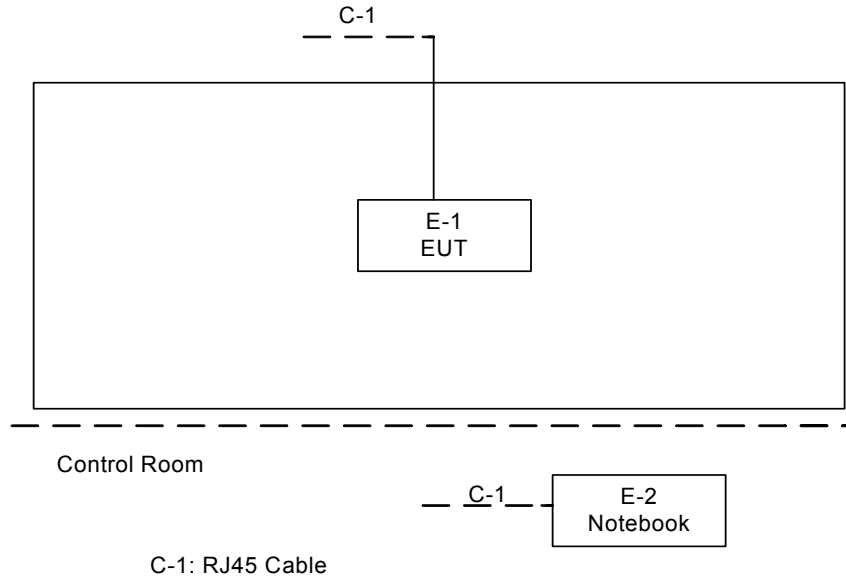



3.5 DESCRIPTION OF SUPPORT UNITS

The EUT has been tested as an independent unit together with other necessary accessories or support units. The following support units or accessories were used to form a representative test configuration during the tests.

Item	Equipment	Mfr/Brand	Model/Type No.	FCC ID	Series No.	Note
E-1	Wireless Dual Band Router	netis	WF2471	T58WF2471B	N/A	EUT
E-2	NOTEBOOK	DELL	INSPIRON 1420	DOC	N/A	
E-3	PC	HP	Dx7400	DOC	CNG7430PX0	
E-4	PC	HP	Dx7400	DOC	CNG7430PWL	
E-5	PC	HP	G3321Cx	DOC	CNX8120R16	
E-6	PC	IBM	8705	DOC	L3G4741	
E-7	Terminal	BROADCOM	BCM96358M-30-A1	NA	NA	

Item	Shielded Type	Ferrite Core	Length	Note
C-1	NO	NO	10m	
C-2	NO	NO	10m	
C-3	NO	NO	10m	
C-4	NO	NO	10m	
C-5	NO	NO	10m	

Note:

- (1) The support equipment was authorized by Declaration of Confirmation.
- (2) For detachable type I/O cable should be specified the length in m in 『Length』 column.



4. EMC EMISSION TEST

4.1 CONDUCTED EMISSION MEASUREMENT

4.1.1 POWER LINE CONDUCTED EMISSION Limits (Frequency Range 150KHz-30MHz)

FREQUENCY (MHz)	Class A (dBuV)		Class B (dBuV)		Standard
	Quasi-peak	Average	Quasi-peak	Average	
0.15 -0.5	79.00	66.0	66 - 56 *	56 - 46 *	CISPR
0.50 -5.0	73.00	60.00	56.00	46.00	CISPR
5.0 -30.0	73.00	60.00	60.00	50.00	CISPR

0.15 -0.5	79.00	66.00	66 - 56 *	56 - 46 *	FCC
0.50 -5.0	73.00	60.00	56.00	46.00	FCC
5.0 -30.0	73.00	60.00	60.00	50.00	FCC

Note:

- (1) The tighter limit applies at the band edges.
- (2) The limit of " * " marked band means the limitation decreases linearly with the logarithm of the frequency in the range.

4.1.2 MEASUREMENT INSTRUMENTS LIST AND SETTING

Item	Kind of Equipment	Manufacturer	Type No.	Serial No.	Last Calibration	Next Calibration
1	LISN	EMCO	3816/2	00052765	May.26.2012	May.04.2013
2	LISN	R&S	ENV216	100087	May.26.2012	May.04.2013
3	Test Cable	N/A	C_17	N/A	Mar.18.2012	Mar.28.2013
4	EMI TEST RECEIVER	R&S	ESCS30	826547/02 2	May.26.2012	May.04.2013
5	50Ω Terminator	SHX	TF2-3G-A	08122902	May.26.2012	May.04.2013

Remark: "N/A" denotes no model name, serial no. or calibration specified.
All calibration period of Equipment List is One Year.

The following table is the setting of the receiver

Receiver Parameters	Setting
Attenuation	10 dB
Start Frequency	0.15 MHz
Stop Frequency	30 MHz
IF Bandwidth	9 kHz

4.1.3 TEST PROCEDURE

- The EUT was placed 0.8 meters from the horizontal ground plane with EUT being connected to the power mains through a line impedance stabilization network (LISN). All other support equipments powered from additional LISN(s). The LISN provide 50 Ohm/ 50uH of coupling impedance for the measuring instrument.
- Interconnecting cables that hang closer than 40 cm to the ground plane shall be folded back and forth in the center forming a bundle 30 to 40 cm long.
- I/O cables that are not connected to a peripheral shall be bundled in the center. The end of the cable may be terminated, if required, using the correct terminating impedance. The overall length shall not exceed 1 m.
- LISN at least 80 cm from nearest part of EUT chassis.
- For the actual test configuration, please refer to the related Item –EUT Test Photos.

4.1.4 DEVIATION FROM TEST STANDARD

No deviation

4.1.5 TEST SETUP

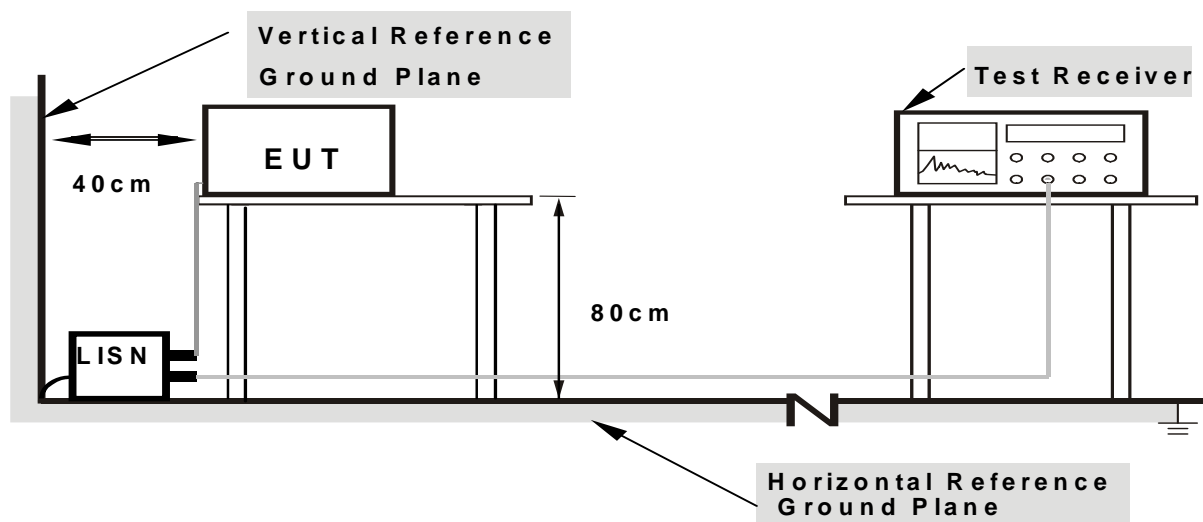

Note: 1. Support units were connected to second LISN.

2. Both of LISNs (AMN) are 80 cm from EUT and at least 80 cm from other units and other metal planes

4.1.6 EUT OPERATING CONDITIONS

The EUT was configured for testing in a typical fashion (as a customer would normally use it). The EUT has been programmed to continuously transmit during test. This operating condition was tested and used to collect the included data.

The EUT was programmed to be in continuously transmitting/Normal Link mode.



4.1.7 TEST RESULTS

Remark

- (1) All readings are QP Mode value unless otherwise stated AVG in column of『Note』. If the QP Mode Measured value compliance with the QP Limits and lower than AVG Limits, the EUT shall be deemed to meet both QP & AVG Limits and then only QP Mode was measured, but AVG Mode didn't perform ◦ In this case, a “ * ” marked in AVG Mode column of Interference Voltage Measured ◦
- (2) Measuring frequency range from 150KHz to 30MHz ◦



EUT :	Wireless Dual Band Router	Model Name :	WF2471
Temperature :	25 °C	Relative Humidity :	53 %
Pressure :	1010hPa	Test Power :	AC 120V/60Hz
Test Mode :	Normal Link	Phase:	Line

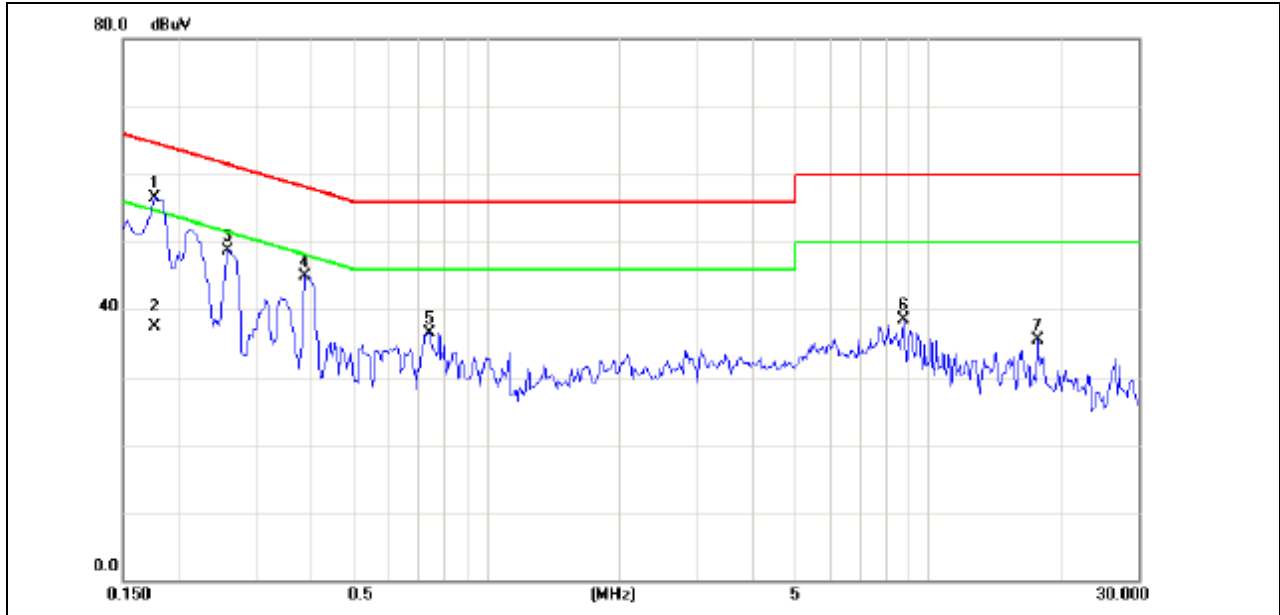

No.	Mk.	Freq. MHz	Reading Level dBuV	Correct Factor dB	Measure- ment dBuV	Limit dBuV	Over dB	Detector	Comment
1	*	0.1773	47.02	9.58	56.60	64.61	-8.01	peak	
2		0.1773	28.00	9.58	37.58	54.61	-17.03	AVG	
3		0.2594	39.08	9.60	48.68	61.45	-12.77	peak	
4		0.3883	35.28	9.63	44.91	58.10	-13.19	peak	
5		0.7438	26.88	9.67	36.55	56.00	-19.45	peak	
6		8.8047	28.40	10.14	38.54	60.00	-21.46	peak	
7		17.6953	25.02	10.40	35.42	60.00	-24.58	peak	



EUT :	Wireless Dual Band Router	Model Name :	WF2471
Temperature :	25 °C	Relative Humidity :	53 %
Pressure :	1010hPa	Test Power :	AC 120V/60Hz
Test Mode :	Normal Link	Phase:	Neutral

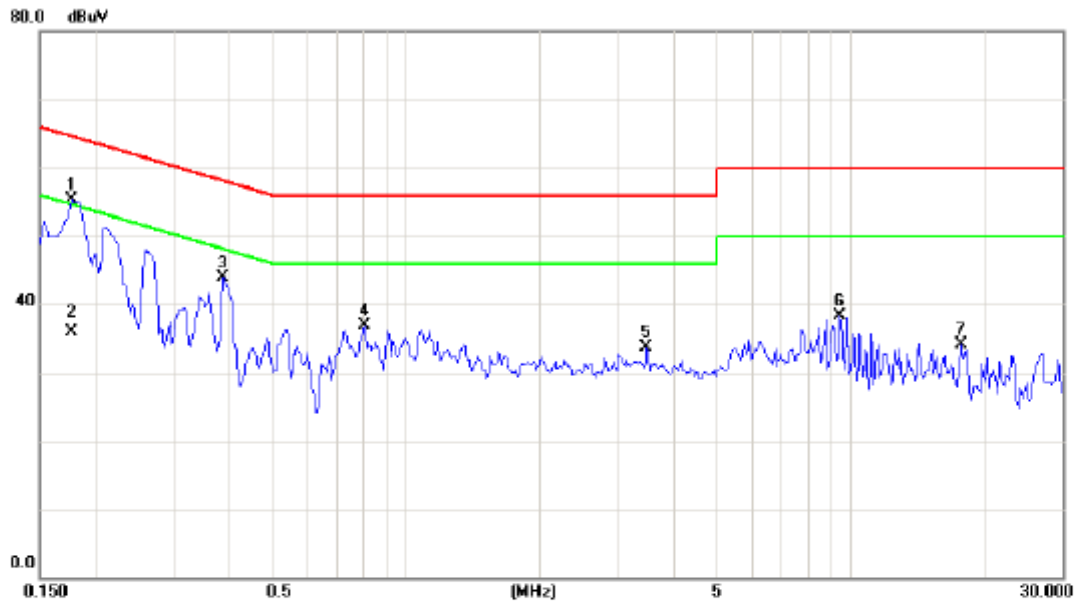

No.	Mk.	Freq. MHz	Reading Level dBuV	Correct Factor dB	Measure- ment dBuV	Limit dBuV	Over dB	Detector	Comment
1	*	0.1773	45.70	9.56	55.26	64.61	-9.35	peak	
2		0.1773	26.40	9.56	35.96	54.61	-18.65	AVG	
3		0.3883	34.32	9.65	43.97	58.10	-14.13	peak	
4		0.8102	27.24	9.74	36.98	56.00	-19.02	peak	
5		3.4844	23.76	9.96	33.72	56.00	-22.28	peak	
6		9.4805	28.04	10.22	38.26	60.00	-21.74	peak	
7		17.6953	23.70	10.43	34.13	60.00	-25.87	peak	



4.2 RADIATED EMISSION MEASUREMENT

4.2.1 RADIATED EMISSION LIMITS (Frequency Range 9KHz-1000MHz)

20dBc in any 100 kHz bandwidth outside the operating frequency band. In case the emission fall within the restricted band specified on 15.205(a), then the 15.209(a) limit in the table below has to be followed.

Frequencies (MHz)	Field Strength (micorvolts/meter)	Measurement Distance (meters)
0.009~0.490	2400/F(KHz)	300
0.490~1.705	24000/F(KHz)	30
1.705~30.0	30	30
30~88	100	3
88~216	150	3
216~960	200	3
Above 960	500	3

LIMITS OF RADIATED EMISSION MEASUREMENT (Above 1000MHz)

FREQUENCY (MHz)	(dBuV/m) (at 1.5m)	
	PEAK	AVERAGE
Above 1000	80	60

Notes:

- (1) The limit for radiated test was performed according to FCC PART 15C.
- (2) The tighter limit applies at the band edges.
- (3) Emission level (dBuV/m)=20log Emission level (uV/m).
 The limits above 5GHz shall be extrapolated to the specified distance using an extrapolation factor of 20dB/decade form 3m to 1.5m
 Distance extrapolation factor = 20 log (3m/1.5m) dB ;
 Limit line = specific limits (dBuV) + 6 dB

FREQUENCY RANGE OF RADIATED MEASUREMENT (For unintentional radiators)

Highest frequency generated or Upper frequency of measurement used in the device or on which the device operates or tunes (MHz)	Range (MHz)
Below 1.705	30
1.705 – 108	1000
108 – 500	2000
500 – 1000	5000
Above 1000	5 th harmonic of the highest frequency or 40 GHz, whichever is lower



4.2.2 MEASUREMENT INSTRUMENTS LIST AND SETTING

Item	Kind of Equipment	Manufacturer	Type No.	Serial No.	Last Calibration	Next Calibration
1	Antenna	Schwarbeck	VULB9160	9160-3232	Jun .04.2012	May.25.2013
2	Amplifier	HP	8447D	2944A09673	May.26.2012	May.04.2013
3	Test Receiver	R&S	ESCI	100382	May.26.2012	May.04.2013
4	Test Cable	N/A	C-01_CB03	N/A	Jul.01.2011	Jul.01.2013
5	Antenna	ETS	3115	00075789	May.26.2012	May.25.2013
6	Amplifier	Agilent	8449B	3008A02274	May.26.2012	May.04.2013
7	Spectrum	Agilent	E4408B	US39240143	Nov.25.2011	Nov.25.2012
8	Test Cable	HUBER+SUHNER	C-45	N/A	May.04.2012	May.02.2013
9	Controller	CT	SC100	N/A	N/A	N/A
10	Active Loop Antenna	R&S	HFH2-Z2	830749/020	May.26.2012	May.04.2013
11	Broad-Band Horn Antenna	Schwarzbeck	BBHA 9170	9170319	Oct.13.2012	Oct.13.2013
12	Horn Antenna	EMCO	3115	9605-4803	May.26.2012	May.25.2013

Remark: "N/A" denotes no model name, serial no. or calibration specified.

All calibration period of Equipment List is One Year.

Spectrum Parameter	Setting
Attenuation	Auto
Start Frequency	1000 MHz
Stop Frequency	10th carrier harmonic
RB / VB (Emission in restricted band)	1MHz / 1MHz for Peak, 1 MHz / 10Hz for Average

Receiver Parameter	Setting
Attenuation	Auto
Start ~ Stop Frequency	9kHz~90kHz for PK/AVG detector
Start ~ Stop Frequency	90kHz~110kHz for QP detector
Start ~ Stop Frequency	110kHz~490kHz for PK/AVG detector
Start ~ Stop Frequency	490kHz~30MHz for QP detector
Start ~ Stop Frequency	30MHz~1000MHz for QP detector



4.2.3 TEST PROCEDURE

- a. The measuring distance of at 1.5 m shall be used for measurements at frequency up to 1GHz. For frequencies above 1GHz, any suitable measuring distance may be used.
- b. The EUT was placed on the top of a rotating table 0.8 meters above the ground at a 3 meter semi-anechoic chamber. The table was rotated 360 degrees to determine the position of the highest radiation.
- c. The height of the equipment or of the substitution antenna shall be 0.8 m; the height of the test antenna shall vary between 1 m to 4 m. Both horizontal and vertical polarizations of the antenna are set to make the measurement.
- d. The initial step in collecting conducted emission data is a spectrum analyzer peak detector mode pre-scanning the measurement frequency range. Significant peaks are then marked and then Quasi Peak detector mode re-measured.
- e. If the Peak Mode measured value compliance with and lower than Quasi Peak Mode Limit, the EUT shall be deemed to meet QP Limits and then no additional QP Mode measurement performed.
- f. For the actual test configuration, please refer to the related Item –EUT Test Photos.

4.2.4 DEVIATION FROM TEST STANDARD

No deviation

4.2.5 TEST SETUP

(A) Radiated Emission Test Set-Up Frequency Below 1 GHz

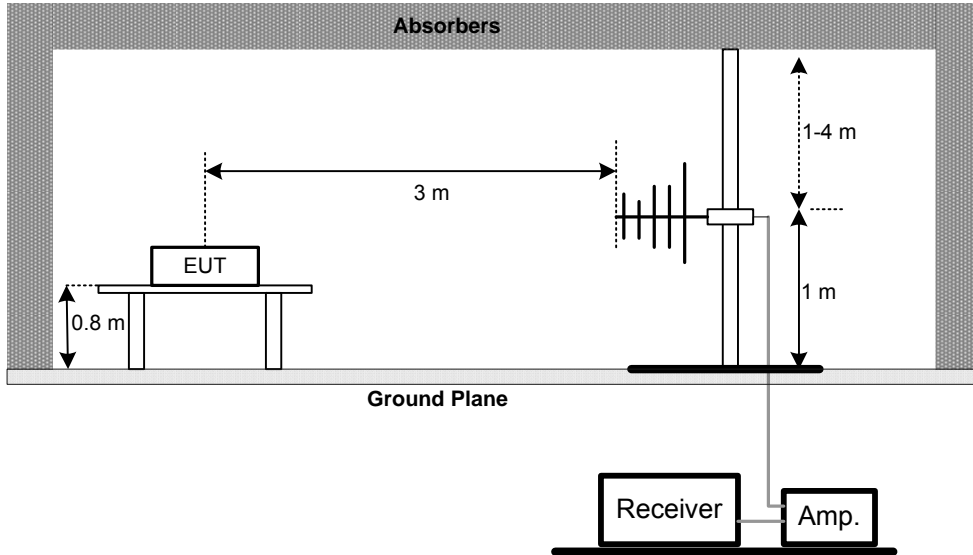

(B) Radiated Emission Test Set-Up Frequency Above 1 GHz

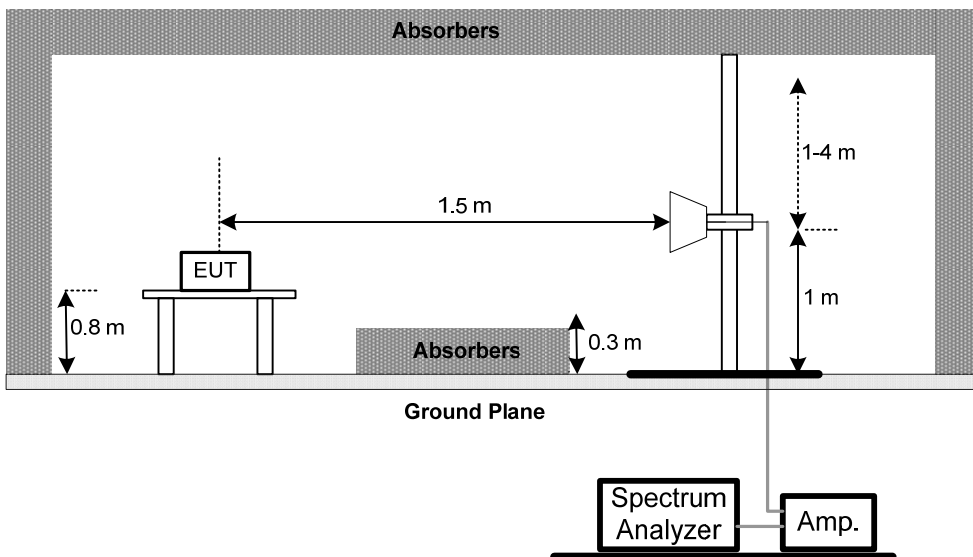

4.2.6 EUT OPERATING CONDITIONS

The EUT tested system was configured as the statements of 4.1.6 Unless otherwise a special operating condition is specified in the follows during the testing.



4.2.7 TEST RESULTS (BETWEEN 30 – 1000 MHZ)

Remark :

- (1) Reading in which marked as QP or Peak means measurements by using are Quasi-Peak Mode or Peak Mode with Detector BW=120KHz ; SPA setting in RBW=120KHz, VBW =120KHz, Swp. Time = 0.3 sec./MHz ◦
- (2) All readings are Peak unless otherwise stated QP in column of 『Note』 . Peak denotes that the Peak reading compliance with the QP Limits and then QP Mode measurement didn't perform ◦
- (3) Measuring frequency range from 30MHz to 1000MHz ◦
- (4) If the peak scan value lower limit more than 20dB, then this signal data does not show in table ◦



EUT :	Wireless Dual Band Router	Model Name :	WF2471
Temperature :	25°C	Relative Humidity :	58 %
Pressure :	1010 hPa	Test Voltage :	AC 120V/60Hz
Test Mode :	TX A Mode 5745MHz	Phase:	Vertical

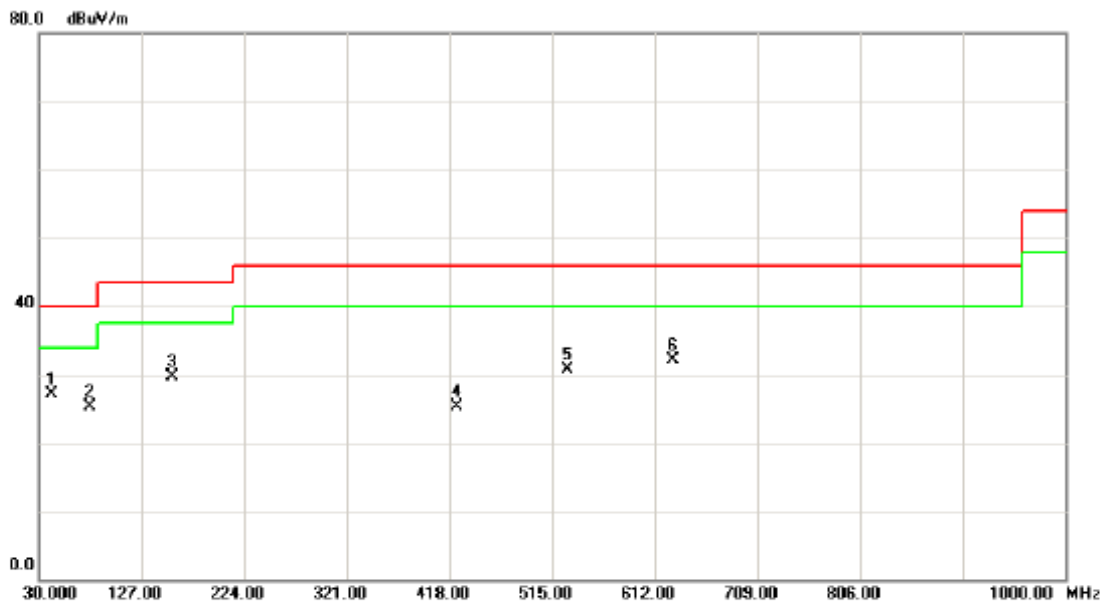

No.	Mk.	Freq. MHz	Reading Level dBuV	Correct Factor dB	Measure- ment dBuV/m	Limit dBuV/m	Over dB	Detector	Comment
1	*	42.1250	43.86	-16.77	27.09	40.00	-12.91	peak	
2		78.5000	44.49	-19.14	25.35	40.00	-14.65	peak	
3		156.1000	47.54	-17.91	29.63	43.50	-13.87	peak	
4		425.2750	34.67	-9.41	25.26	46.00	-20.74	peak	
5		529.5500	38.07	-7.33	30.74	46.00	-15.26	peak	
6		628.9750	37.14	-5.01	32.13	46.00	-13.87	peak	



Neutron Engineering Inc.

EUT :	Wireless Dual Band Router	Model Name :	WF2471
Temperature :	25°C	Relative Humidity :	58 %
Pressure :	1010 hPa	Test Voltage :	AC 120V/60Hz
Test Mode :	TX A Mode 5745MHz	Phase:	Horizontal

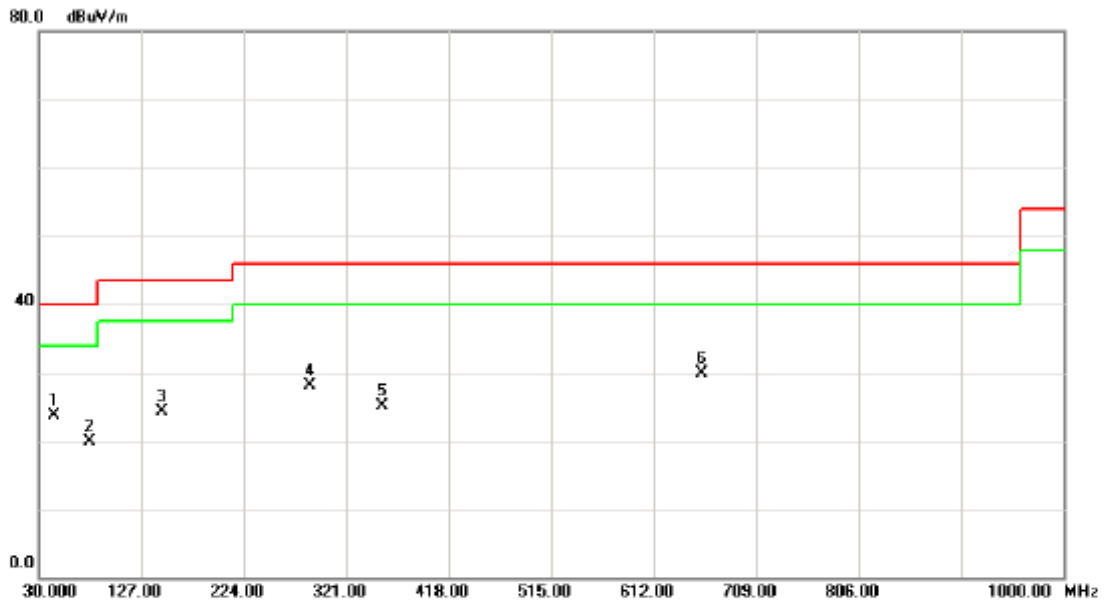

No.	Mk.	Freq. MHz	Reading Level dBuV	Correct Factor dB	Measure- ment dBuV/m	Limit dBuV/m	Over dB	Detector	Comment
1		44.5500	40.85	-17.08	23.77	40.00	-16.23	peak	
2		78.5000	39.11	-19.14	19.97	40.00	-20.03	peak	
3		146.4000	42.22	-17.90	24.32	43.50	-19.18	peak	
4		287.0500	40.91	-12.77	28.14	46.00	-17.86	peak	
5		354.9500	36.50	-11.36	25.14	46.00	-20.86	peak	
6	*	658.0750	34.66	-4.66	30.00	46.00	-16.00	peak	



4.2.8 TEST RESULTS (ABOVE 1000 MHZ)

EUT :	Wireless Dual Band Router	Model Name :	WF2471
Temperature :	25 °C	Relative Humidity :	58 %
Pressure :	1010 hPa	Test Voltage :	AC 120V/60Hz
Test Mode :	TX A Mode 5745MHz		

Freq. (MHz)	Ant.Pol. H/V	Reading		Ant./CF CF(dB)	Act.		Limit		Note
		Peak (dBuV)	AV (dBuV)		Peak (dBuV/m)	AV (dBuV/m)	Peak (dBuV/m)	AV (dBuV/m)	
# 5725.00	V	47.91	26.75	41.90	89.81	68.65	99.76	89.51	X/E
5745.00	V	77.78	67.53	41.98	119.76	109.51			X/F
11490.26	V	49.25	40.18	13.27	62.52	53.45	80.00	60.00	X/H

Remark :

- (1) All readings are Peak unless otherwise stated QP in column of 『Note』 . Peak denotes that the Peak reading compliance with the QP Limits and then QP Mode measurement didn't perform ◦
- (2) Measuring frequency range from 30MHz to 1000MHz or the 10th harmonic of highest fundamental frequency ◦ "F" denotes fundamental frequency; "H" denotes spurious frequency. "E" denotes band edge frequency. (This judgment method includes the Band Edge Requirement.)
- (3) Radiated emissions measured in frequency range above 1000MHz were made with an instrument using Peak detector mode and AV detector mode of the emission ◦
- (4) Data of measurement within this frequency range shown " * " in the table above means the reading of emissions are attenuated more than 20dB below the permissible limits or the field strength is too small to be measured.
- (5) A preamp and high pass filter were used for this test in order to provide sufficient measurement sensitivity.
- (6) EUT Orthogonal Axis :
"X" - denotes Laid on Table ; "Y" - denotes Vertical Stand ; "Z" - denotes Side Stand
- (7) During the measurements above 1 GHz it is taken care of that the EUT is always within the 3 dB cone of radiation BW of the used antenna
- (8) The limits above 5GHz shall be extrapolated to the specified distance using an extrapolation factor of 20dB/decade form 3m to 1.5m
Distance extrapolation factor = 20 log (3m/1.5m) dB ;
Limit line = specific limits (dBuV) + 6 dB
- (9) "#" The radiated frequency is out of the restricted band. Limit line= fundamental - 20dB



TX CH149 (Above 1000 MHz, Vertical)

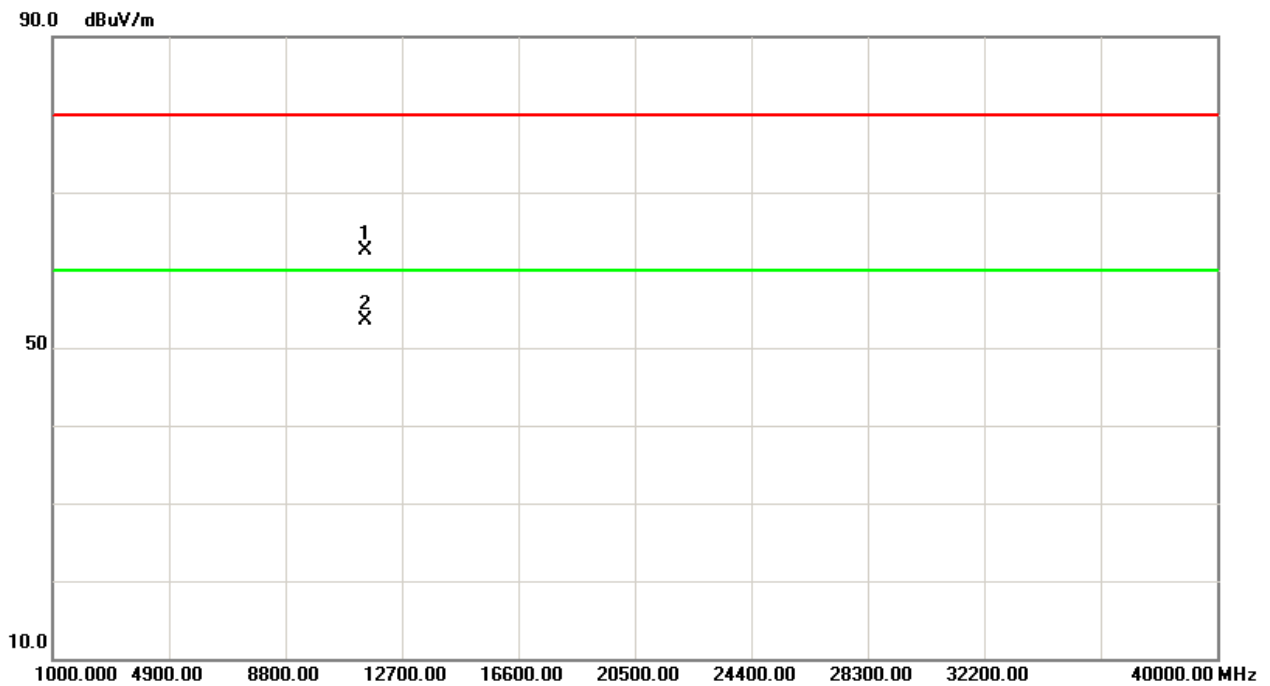
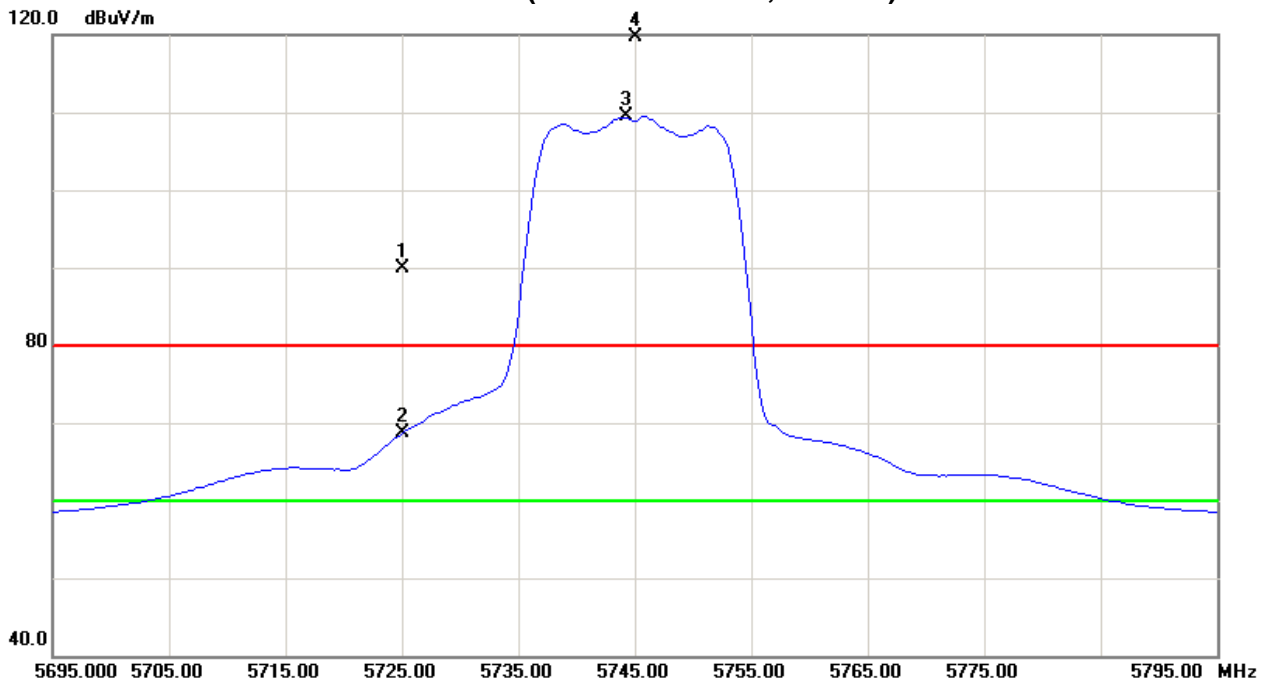



EUT :	Wireless Dual Band Router	Model Name :	WF2471
Temperature :	25 °C	Relative Humidity :	58 %
Pressure :	1010 hPa	Test Voltage :	AC 120V/60Hz
Test Mode :	TX A Mode 5745MHz		

Freq.	Ant.Pol.	Reading		Ant./CF	Act.		Limit		Note
		Peak	AV		Peak	AV	Peak	AV	
(MHz)	H/V	(dBuV)	(dBuV)	CF(dB)	(dBuV/m)	(dBuV/m)	(dBuV/m)	(dBuV/m)	
# 5725.00	H	30.11	17.20	41.90	72.01	59.10	86.15	74.68	X/E
5745.75	H	64.16	52.69	41.99	106.15	94.68			X/F
11489.85	H	48.57	38.46	13.27	61.84	51.73	80.00	60.00	X/H

Remark :

- (1) All readings are Peak unless otherwise stated QP in column of 『Note』 . Peak denotes that the Peak reading compliance with the QP Limits and then QP Mode measurement didn't perform ◦
- (2) Measuring frequency range from 30MHz to 1000MHz or the 10th harmonic of highest fundamental frequency ◦ "F" denotes fundamental frequency; "H" denotes spurious frequency. "E" denotes band edge frequency. (This judgment method includes the Band Edge Requirement.)
- (3) Radiated emissions measured in frequency range above 1000MHz were made with an instrument using Peak detector mode and AV detector mode of the emission ◦
- (4) Data of measurement within this frequency range shown " * " in the table above means the reading of emissions are attenuated more than 20dB below the permissible limits or the field strength is too small to be measured.
- (5) A preamp and high pass filter were used for this test in order to provide sufficient measurement sensitivity.
- (6) EUT Orthogonal Axis :
"X" - denotes Laid on Table ; "Y" - denotes Vertical Stand ; "Z" - denotes Side Stand
- (7) During the measurements above 1 GHz it is taken care of that the EUT is always within the 3 dB cone of radiation BW of the used antenna
- (8) The limits above 5GHz shall be extrapolated to the specified distance using an extrapolation factor of 20dB/decade form 3m to 1.5m
Distance extrapolation factor = 20 log (3m/1.5m) dB ;
Limit line = specific limits (dBuV) + 6 dB
- (9) "#" The radiated frequency is out of the restricted band. Limit line= fundamental - 20dB



TX CH149 (Above 1000 MHz, Horizontal)

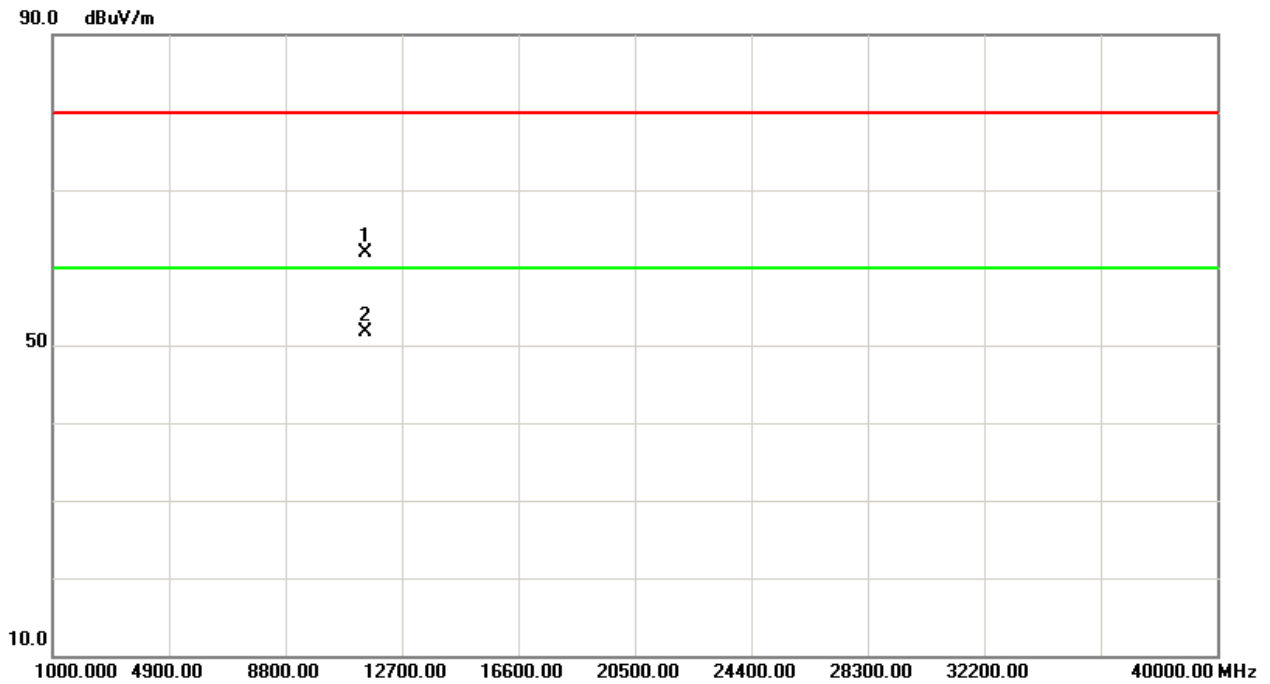
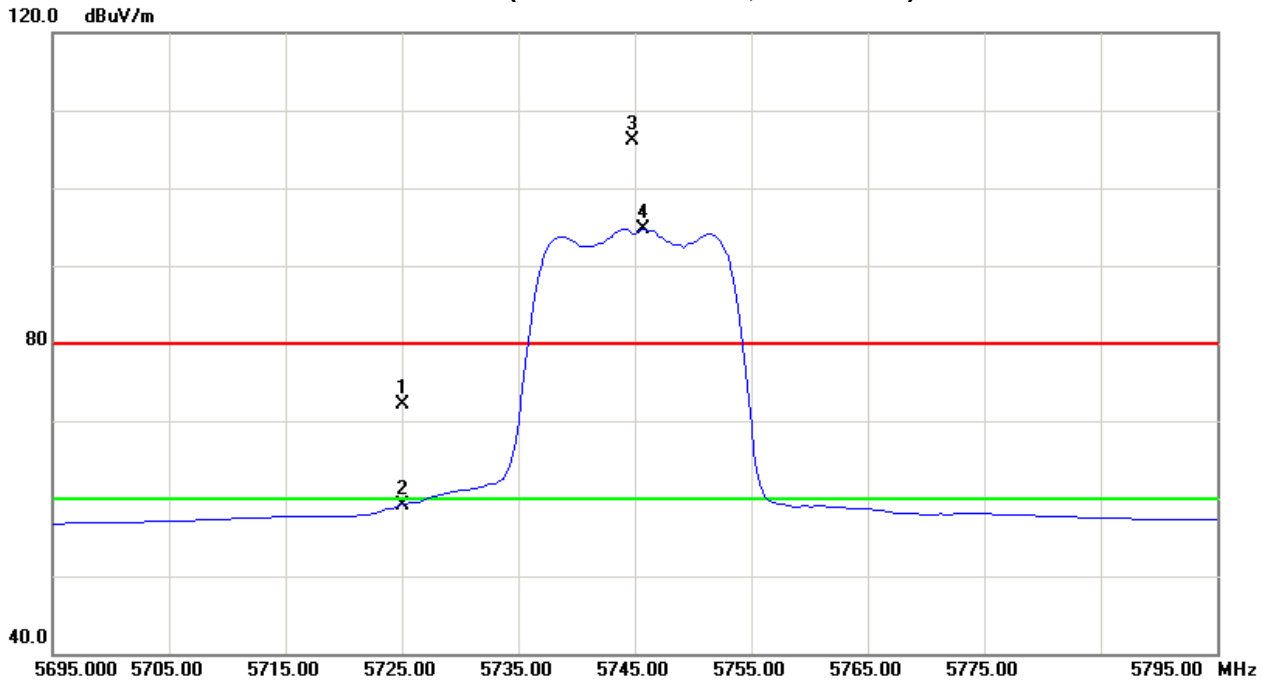



EUT :	Wireless Dual Band Router	Model Name :	WF2471
Temperature :	25 °C	Relative Humidity :	58 %
Pressure :	1010 hPa	Test Voltage :	AC 120V/60Hz
Test Mode :	TX A Mode 5785MHz		

Freq.	Ant.Pol.	Reading		Ant./CF	Act.		Limit		Note
		Peak	AV		Peak	AV	Peak	AV	
(MHz)	H/V	(dBuV)	(dBuV)	CF(dB)	(dBuV/m)	(dBuV/m)	(dBuV/m)	(dBuV/m)	
5785.75	V	77.57	66.84	42.14	119.71	108.98			X/F
11569.95	V	50.19	40.44	13.36	63.55	53.80	80.00	60.00	X/H

Remark :

- (1) All readings are Peak unless otherwise stated QP in column of 『Note』 . Peak denotes that the Peak reading compliance with the QP Limits and then QP Mode measurement didn't perform ◦
- (2) Measuring frequency range from 30MHz to 1000MHz or the 10th harmonic of highest fundamental frequency ◦ "F" denotes fundamental frequency; "H" denotes spurious frequency. "E" denotes band edge frequency. (This judgment method includes the Band Edge Requirement.)
- (3) Radiated emissions measured in frequency range above 1000MHz were made with an instrument using Peak detector mode and AV detector mode of the emission ◦
- (4) Data of measurement within this frequency range shown " * " in the table above means the reading of emissions are attenuated more than 20dB below the permissible limits or the field strength is too small to be measured.
- (5) A preamp and high pass filter were used for this test in order to provide sufficient measurement sensitivity.
- (6) EUT Orthogonal Axis :
 "X" - denotes Laid on Table ; "Y" - denotes Vertical Stand ; "Z" - denotes Side Stand
- (7) During the measurements above 1 GHz it is taken care of that the EUT is always within the 3 dB cone of radiation BW of the used antenna
- (8) The limits above 5GHz shall be extrapolated to the specified distance using an extrapolation factor of 20dB/decade form 3m to 1.5m
 Distance extrapolation factor = $20 \log (3m/1.5m)$ dB ;
 Limit line = specific limits (dBuV) + 6 dB



TX CH157 (Above 1000 MHz, Vertical)

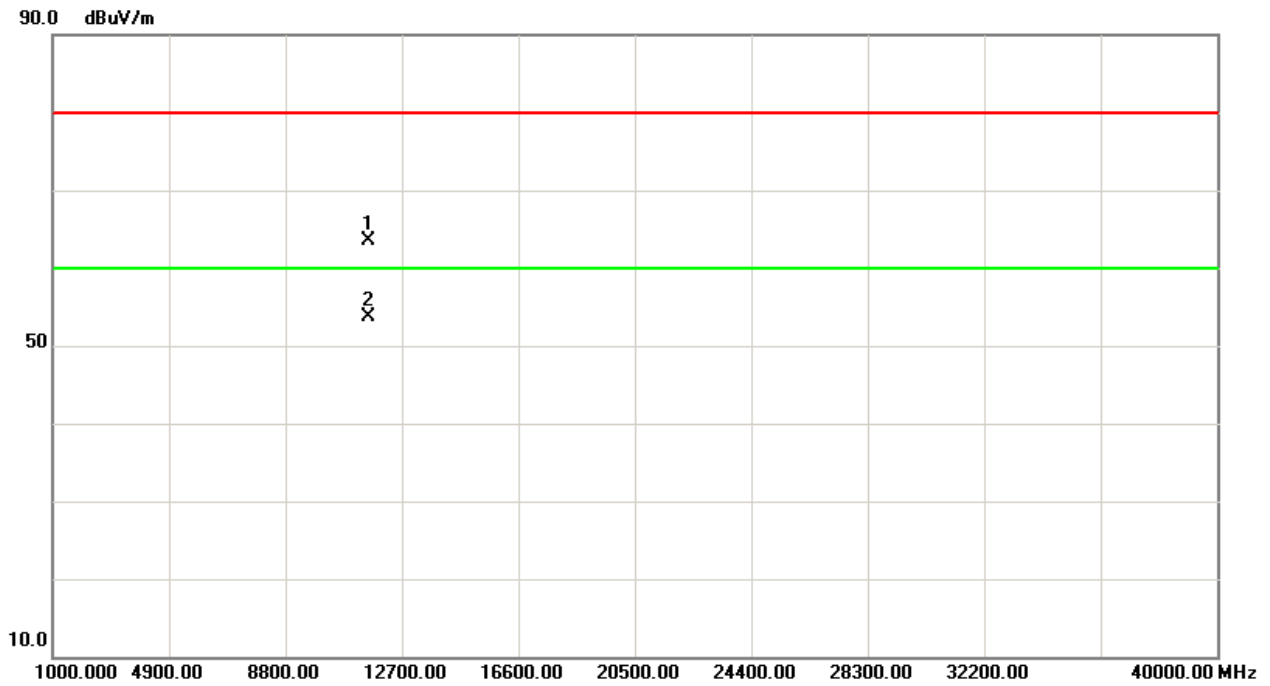
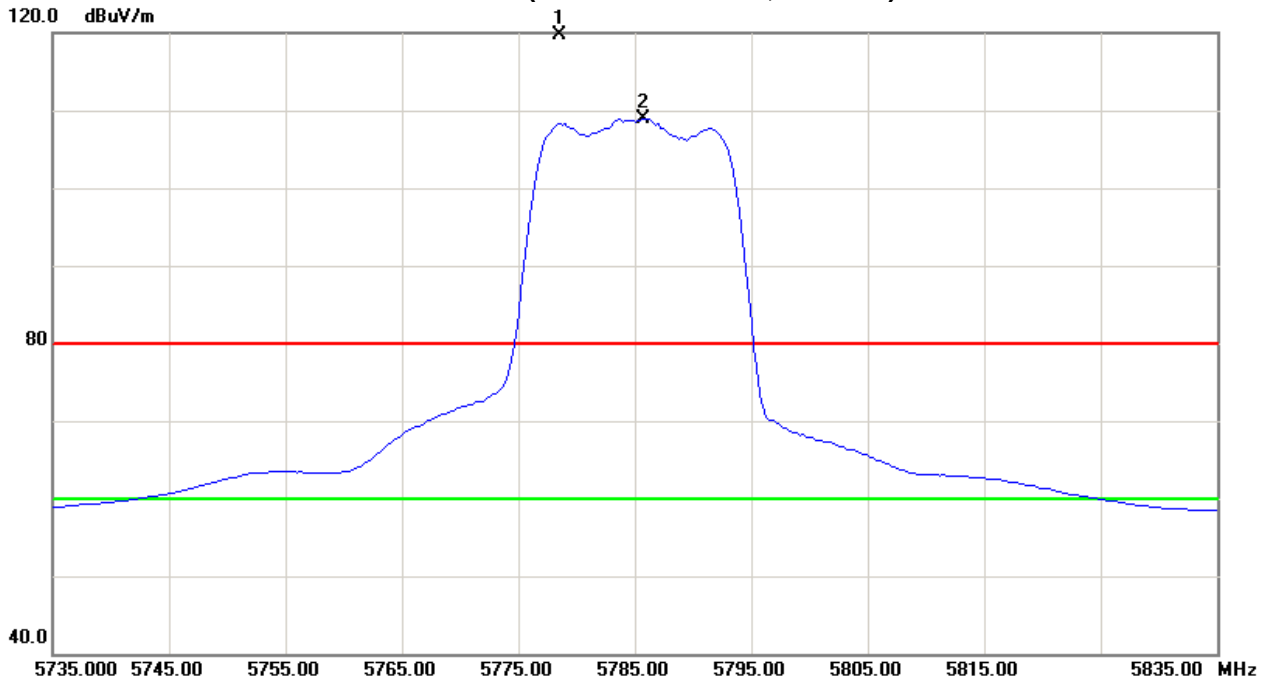



EUT :	Wireless Dual Band Router	Model Name :	WF2471
Temperature :	25 °C	Relative Humidity :	58 %
Pressure :	1010 hPa	Test Voltage :	AC 120V/60Hz
Test Mode :	TX A Mode 5785MHz		

Freq.	Ant.Pol.	Reading		Ant./CF	Act.		Limit		Note
		Peak	AV		Peak	AV	Peak	AV	
(MHz)	H/V	(dBuV)	(dBuV)	CF(dB)	(dBuV/m)	(dBuV/m)	(dBuV/m)	(dBuV/m)	
5784.00	H	62.79	52.26	42.14	104.93	94.40			X/F
11570.40	H	48.49	38.32	13.36	61.85	51.68	80.00	60.00	X/H

Remark :

- (1) All readings are Peak unless otherwise stated QP in column of 『Note』 . Peak denotes that the Peak reading compliance with the QP Limits and then QP Mode measurement didn't perform ◦
- (2) Measuring frequency range from 30MHz to 1000MHz or the 10th harmonic of highest fundamental frequency ◦ "F" denotes fundamental frequency; "H" denotes spurious frequency. "E" denotes band edge frequency. (This judgment method includes the Band Edge Requirement.)
- (3) Radiated emissions measured in frequency range above 1000MHz were made with an instrument using Peak detector mode and AV detector mode of the emission ◦
- (4) Data of measurement within this frequency range shown " * " in the table above means the reading of emissions are attenuated more than 20dB below the permissible limits or the field strength is too small to be measured.
- (5) A preamp and high pass filter were used for this test in order to provide sufficient measurement sensitivity.
- (6) EUT Orthogonal Axis :
 "X" - denotes Laid on Table ; "Y" - denotes Vertical Stand ; "Z" - denotes Side Stand
- (7) During the measurements above 1 GHz it is taken care of that the EUT is always within the 3 dB cone of radiation BW of the used antenna
- (8) The limits above 5GHz shall be extrapolated to the specified distance using an extrapolation factor of 20dB/decade form 3m to 1.5m
 Distance extrapolation factor = 20 log (3m/1.5m) dB ;
 Limit line = specific limits (dBuV) + 6 dB



TX CH157 (Above 1000 MHz, Horizontal)

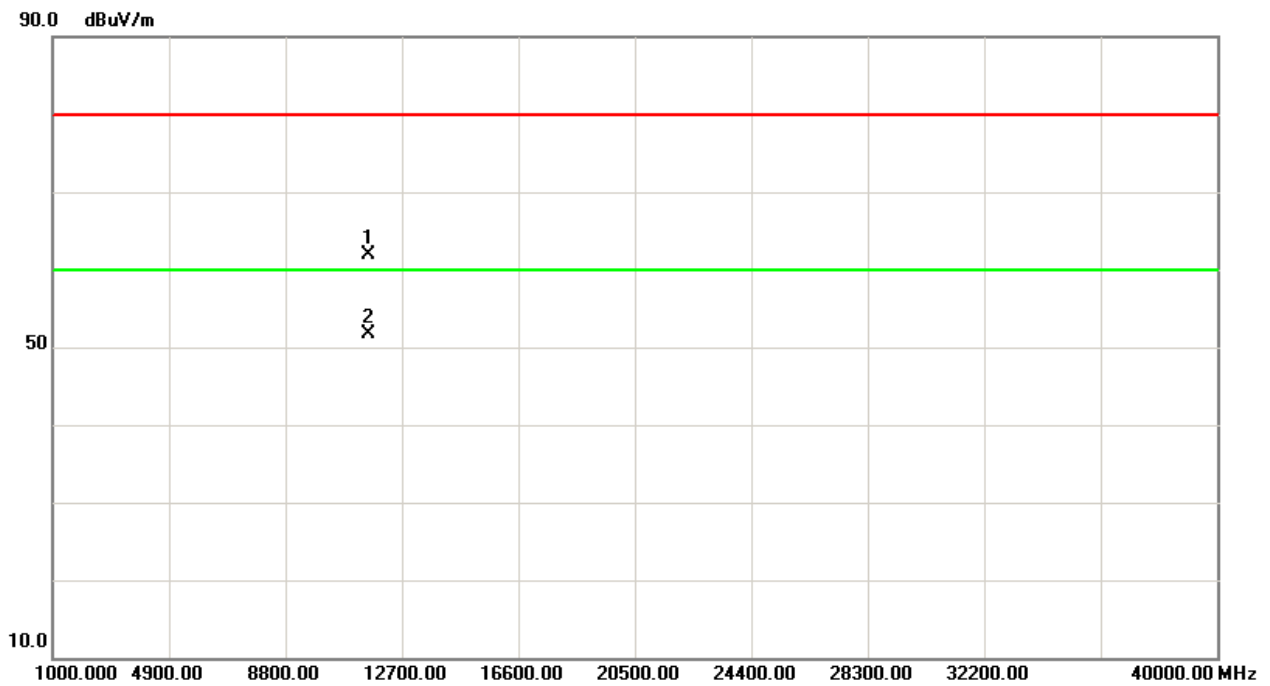
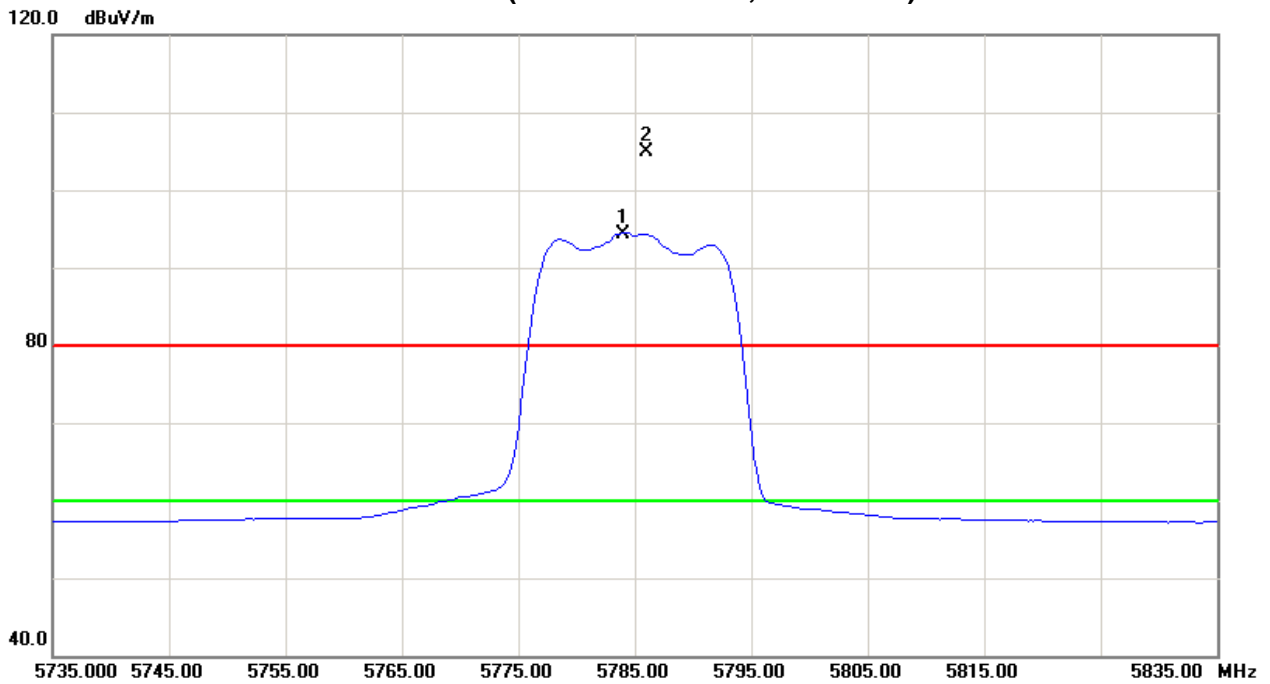



EUT :	Wireless Dual Band Router	Model Name :	WF2471
Temperature :	25 °C	Relative Humidity :	58 %
Pressure :	1010 hPa	Test Voltage :	AC 120V/60Hz
Test Mode :	TX A Mode 5825MHz		

Freq.	Ant.Pol.	Reading		Ant./CF	Act.		Limit		Note
		Peak	AV		Peak	AV	Peak	AV	
(MHz)	H/V	(dBuV)	(dBuV)	CF(dB)	(dBuV/m)	(dBuV/m)	(dBuV/m)	(dBuV/m)	
5825.75	V	77.11	66.38	42.31	119.42	108.69			X/F
# 5850.00	V	32.25	21.16	42.40	74.65	63.56	99.42	88.69	X/E
11650.15	V	50.35	40.28	13.43	63.78	53.71	80.00	60.00	X/H

Remark :

- (1) All readings are Peak unless otherwise stated QP in column of 『Note』 . Peak denotes that the Peak reading compliance with the QP Limits and then QP Mode measurement didn't perform ◦
- (2) Measuring frequency range from 30MHz to 1000MHz or the 10th harmonic of highest fundamental frequency ◦ "F" denotes fundamental frequency; "H" denotes spurious frequency. "E" denotes band edge frequency. (This judgment method includes the Band Edge Requirement.)
- (3) Radiated emissions measured in frequency range above 1000MHz were made with an instrument using Peak detector mode and AV detector mode of the emission ◦
- (4) Data of measurement within this frequency range shown " * " in the table above means the reading of emissions are attenuated more than 20dB below the permissible limits or the field strength is too small to be measured.
- (5) A preamp and high pass filter were used for this test in order to provide sufficient measurement sensitivity.
- (6) EUT Orthogonal Axis :
 "X" - denotes Laid on Table ; "Y" - denotes Vertical Stand ; "Z" - denotes Side Stand
- (7) During the measurements above 1 GHz it is taken care of that the EUT is always within the 3 dB cone of radiation BW of the used antenna
- (8) The limits above 5GHz shall be extrapolated to the specified distance using an extrapolation factor of 20dB/decade form 3m to 1.5m
 Distance extrapolation factor = 20 log (3m/1.5m) dB ;
 Limit line = specific limits (dBuV) + 6 dB
- (9) "# " The radiated frequency is out of the restricted band. Limit line= fundamental - 20dB



TX CH165 (Above 1000 MHz, Vertical)

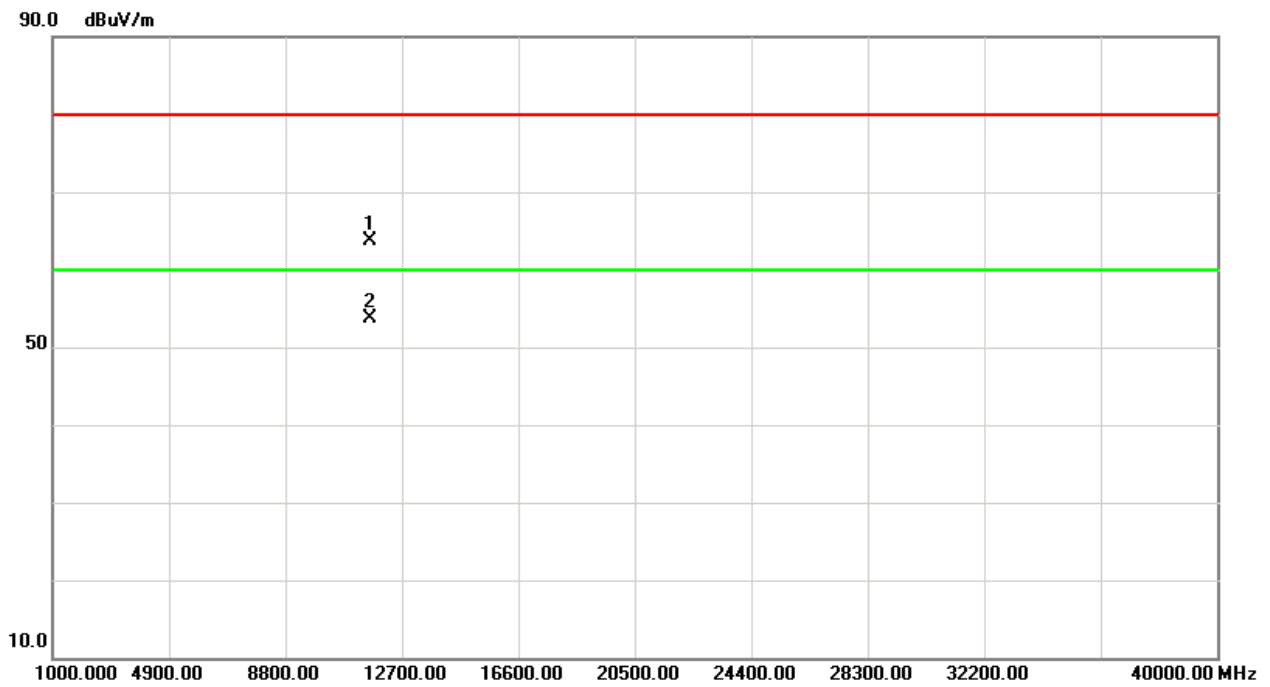
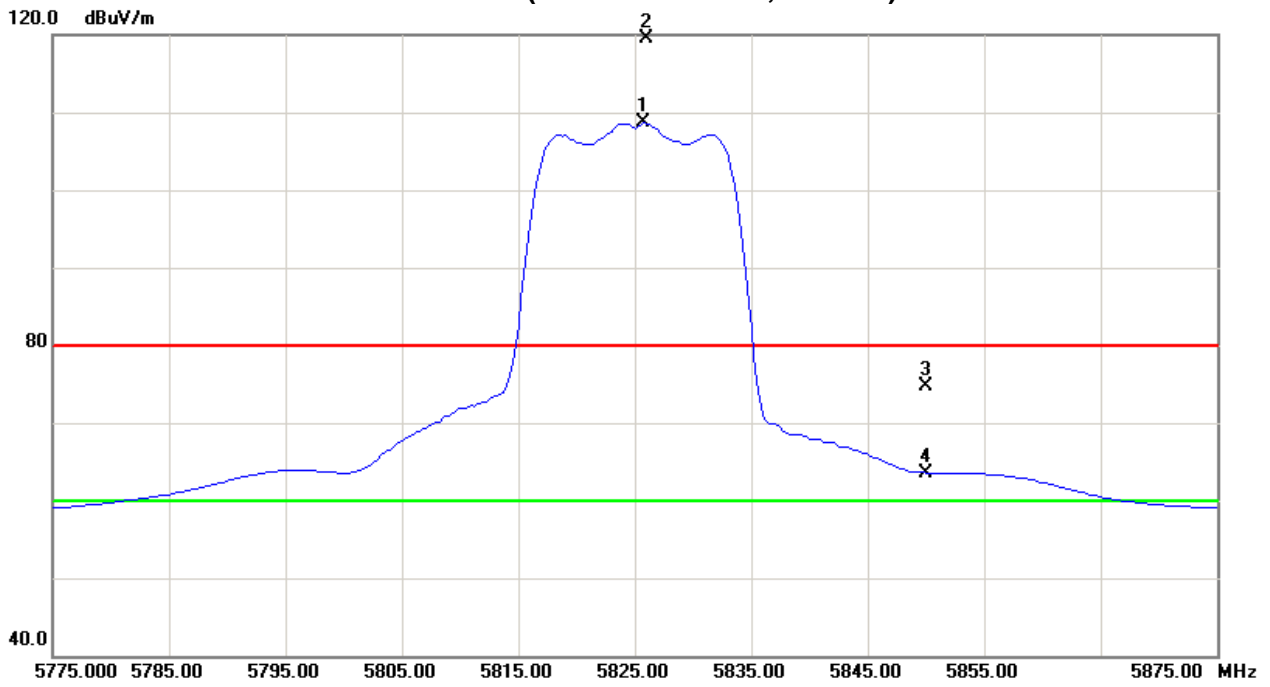



EUT :	Wireless Dual Band Router	Model Name :	WF2471
Temperature :	25 °C	Relative Humidity :	58 %
Pressure :	1010 hPa	Test Voltage :	AC 120V/60Hz
Test Mode :	TX A Mode 5825MHz		

Freq.	Ant.Pol.	Reading		Ant./CF	Act.		Limit		Note
		Peak	AV		Peak	AV	Peak	AV	
(MHz)	H/V	(dBuV)	(dBuV)	CF(dB)	(dBuV/m)	(dBuV/m)	(dBuV/m)	(dBuV/m)	
5826.00	H	63.17	52.44	42.31	105.48	94.75			X/F
# 5850.00	H	29.65	15.43	42.40	72.05	57.83	85.48	74.75	X/E
11649.98	H	48.72	38.54	13.43	62.15	51.97	80.00	60.00	X/H

Remark :

- (1) All readings are Peak unless otherwise stated QP in column of 『Note』 . Peak denotes that the Peak reading compliance with the QP Limits and then QP Mode measurement didn't perform ◦
- (2) Measuring frequency range from 30MHz to 1000MHz or the 10th harmonic of highest fundamental frequency ◦ "F" denotes fundamental frequency; "H" denotes spurious frequency. "E" denotes band edge frequency. (This judgment method includes the Band Edge Requirement.)
- (3) Radiated emissions measured in frequency range above 1000MHz were made with an instrument using Peak detector mode and AV detector mode of the emission ◦
- (4) Data of measurement within this frequency range shown " * " in the table above means the reading of emissions are attenuated more than 20dB below the permissible limits or the field strength is too small to be measured.
- (5) A preamp and high pass filter were used for this test in order to provide sufficient measurement sensitivity.
- (6) EUT Orthogonal Axis :
 "X" - denotes Laid on Table ; "Y" - denotes Vertical Stand ; "Z" - denotes Side Stand
- (7) During the measurements above 1 GHz it is taken care of that the EUT is always within the 3 dB cone of radiation BW of the used antenna
- (8) The limits above 5GHz shall be extrapolated to the specified distance using an extrapolation factor of 20dB/decade form 3m to 1.5m
 Distance extrapolation factor = 20 log (3m/1.5m) dB ;
 Limit line = specific limits (dBuV) + 6 dB
- (9) "#" The radiated frequency is out of the restricted band. Limit line= fundamental - 20dB



TX CH165 (Above 1000 MHz, Horizontal)

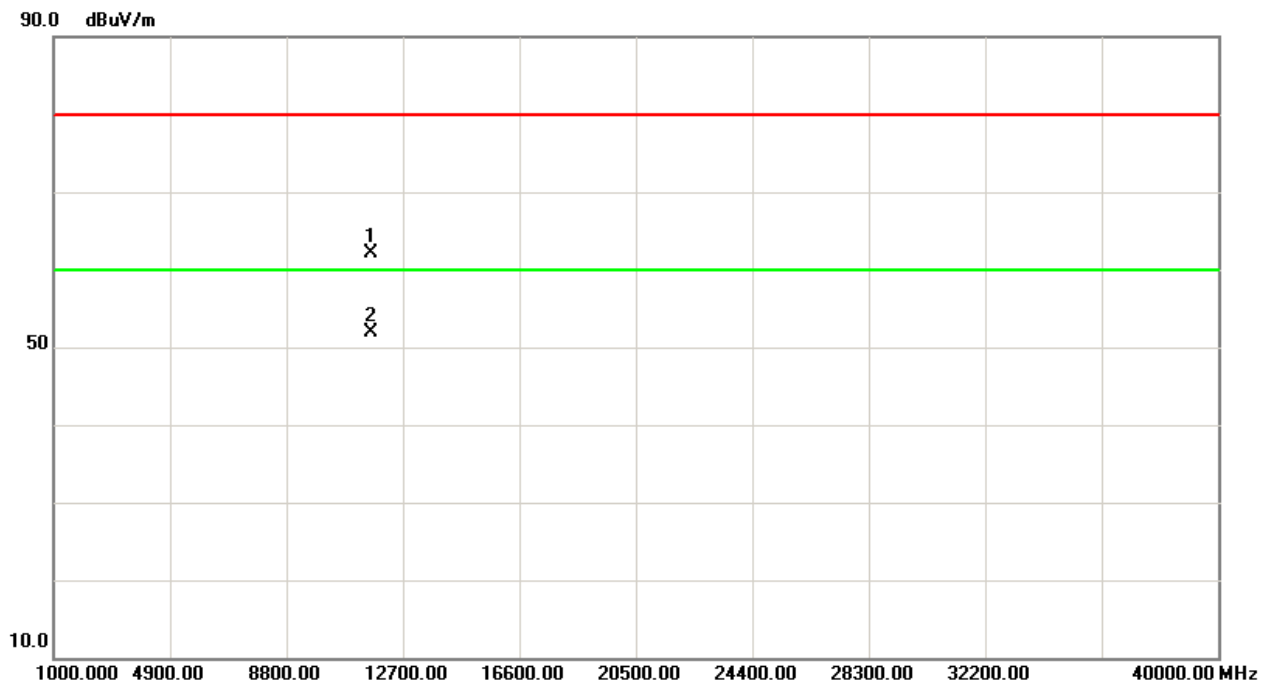
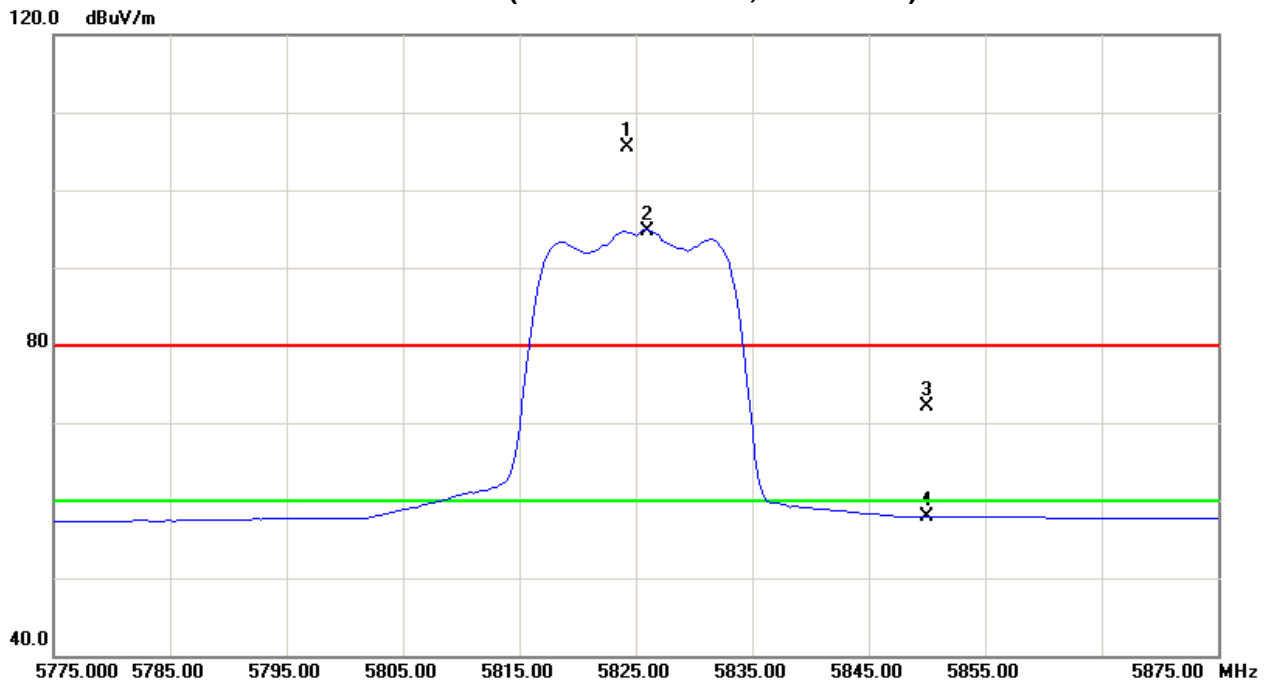



EUT :	Wireless Dual Band Router	Model Name :	WF2471
Temperature :	25 °C	Relative Humidity :	58 %
Pressure :	1010 hPa	Test Voltage :	AC 120V/60Hz
Test Mode :	TX N20 Mode 5745MHz		

Freq. (MHz)	Ant.Pol. HV	Reading		Ant./CF CF(dB)	Act.		Limit		Note
		Peak (dBuV)	AV (dBuV)		Peak (dBuV/m)	AV (dBuV/m)	Peak (dBuV/m)	AV (dBuV/m)	
#5725.00	V	36.81	24.25	41.90	78.71	66.15	100.24	88.24	X/E
5744.25	V	78.26	66.26	41.98	120.24	108.24			X/F
11490.24	V	48.78	38.60	13.27	62.05	51.87	80.00	60.00	X/H

Remark :

- (1) All readings are Peak unless otherwise stated QP in column of 『Note』 . Peak denotes that the Peak reading compliance with the QP Limits and then QP Mode measurement didn't perform ◦
- (2) Measuring frequency range from 30MHz to 1000MHz or the 10th harmonic of highest fundamental frequency ◦ "F" denotes fundamental frequency; "H" denotes spurious frequency. "E" denotes band edge frequency. (This judgment method includes the Band Edge Requirement.)
- (3) Radiated emissions measured in frequency range above 1000MHz were made with an instrument using Peak detector mode and AV detector mode of the emission ◦
- (4) Data of measurement within this frequency range shown " * " in the table above means the reading of emissions are attenuated more than 20dB below the permissible limits or the field strength is too small to be measured.
- (5) A preamp and high pass filter were used for this test in order to provide sufficient measurement sensitivity.
- (6) EUT Orthogonal Axis :
"X" - denotes Laid on Table ; "Y" - denotes Vertical Stand ; "Z" - denotes Side Stand
- (7) During the measurements above 1 GHz it is taken care of that the EUT is always within the 3 dB cone of radiation BW of the used antenna
- (8) The limits above 5GHz shall be extrapolated to the specified distance using an extrapolation factor of 20dB/decade form 3m to 1.5m
Distance extrapolation factor = 20 log (3m/1.5m) dB ;
Limit line = specific limits (dBuV) + 6 dB
- (9) "#" The radiated frequency is out of the restricted band. Limit line= fundamental - 20dB



TX CH149 (Above 1000 MHz, Vertical)

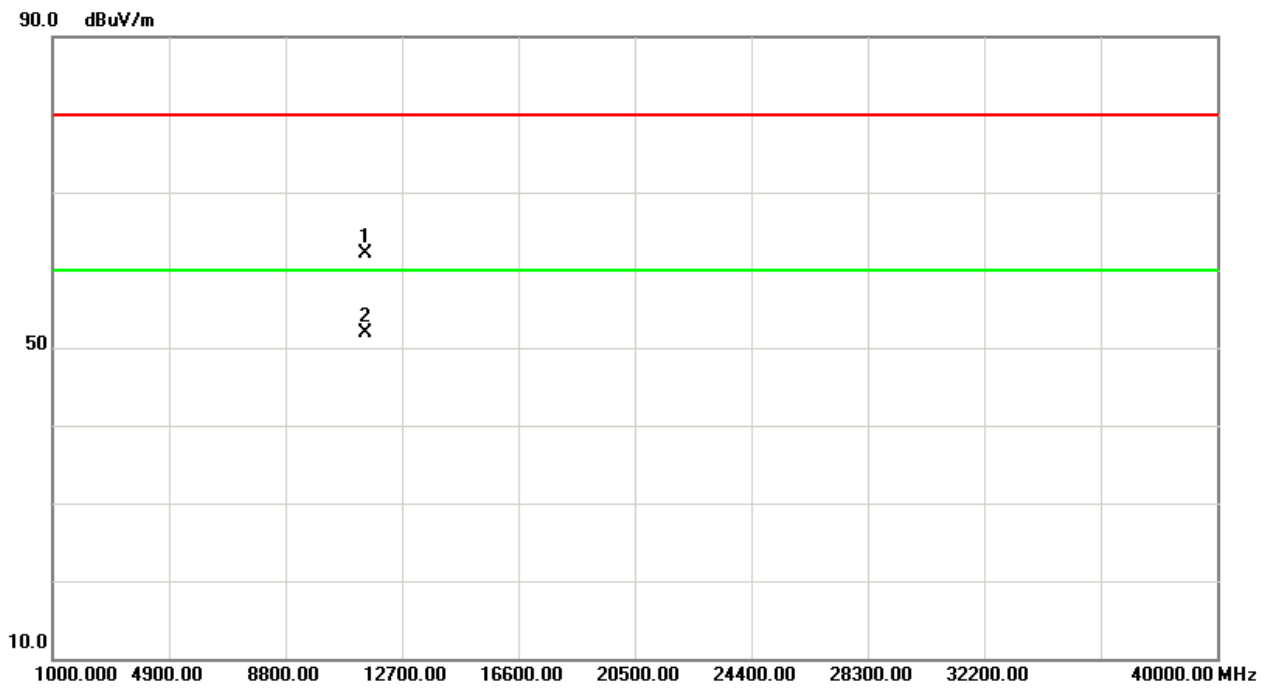
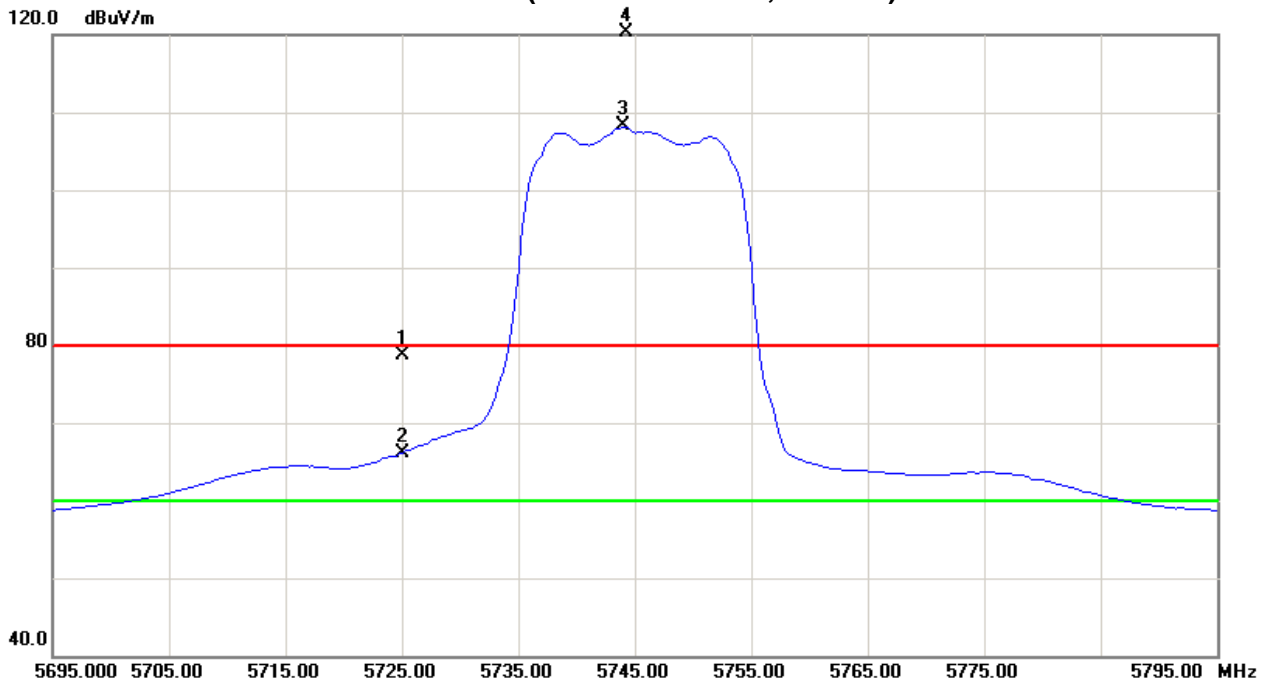



Neutron Engineering Inc.

EUT :	Wireless Dual Band Router	Model Name :	WF2471
Temperature :	25 °C	Relative Humidity :	58 %
Pressure :	1010 hPa	Test Voltage :	AC 120V/60Hz
Test Mode :	TX N20 Mode 5745MHz		

Freq. (MHz)	Ant.Pol. H/V	Reading		Ant./CF CF(dB)	Act.		Limit		Note
		Peak (dBuV)	AV (dBuV)		Peak (dBuV/m)	AV (dBuV/m)	Peak (dBuV/m)	AV (dBuV/m)	
# 5725.00	H	26.57	15.73	41.90	68.47	57.63	83.24	71.54	X/E
5745.25	H	61.26	49.56	41.98	103.24	91.54			X/F
11490.20	H	46.32	36.57	13.27	59.59	49.84	80.00	60.00	X/H

Remark :

- (1) All readings are Peak unless otherwise stated QP in column of 『Note』 . Peak denotes that the Peak reading compliance with the QP Limits and then QP Mode measurement didn't perform ◦
- (2) Measuring frequency range from 30MHz to 1000MHz or the 10th harmonic of highest fundamental frequency ◦ "F" denotes fundamental frequency; "H" denotes spurious frequency. "E" denotes band edge frequency. (This judgment method includes the Band Edge Requirement.)
- (3) Radiated emissions measured in frequency range above 1000MHz were made with an instrument using Peak detector mode and AV detector mode of the emission ◦
- (4) Data of measurement within this frequency range shown " * " in the table above means the reading of emissions are attenuated more than 20dB below the permissible limits or the field strength is too small to be measured.
- (5) A preamp and high pass filter were used for this test in order to provide sufficient measurement sensitivity.
- (6) EUT Orthogonal Axis :
"X" - denotes Laid on Table ; "Y" - denotes Vertical Stand ; "Z" - denotes Side Stand
- (7) During the measurements above 1 GHz it is taken care of that the EUT is always within the 3 dB cone of radiation BW of the used antenna
- (8) The limits above 5GHz shall be extrapolated to the specified distance using an extrapolation factor of 20dB/decade form 3m to 1.5m
Distance extrapolation factor = $20 \log(3m/1.5m)$ dB ;
Limit line = specific limits (dBuV) + 6 dB
- (9) "#" The radiated frequency is out of the restricted band. Limit line= fundamental - 20dB



TX CH149 (Above 1000 MHz, Horizontal)

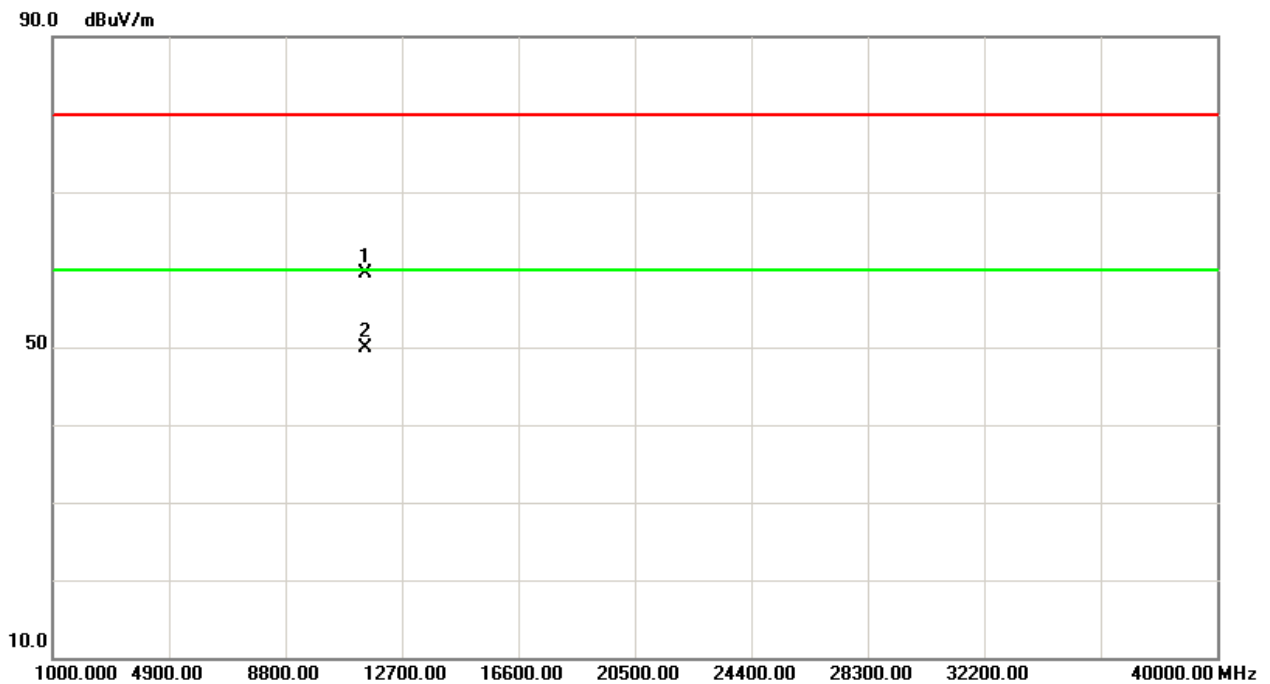
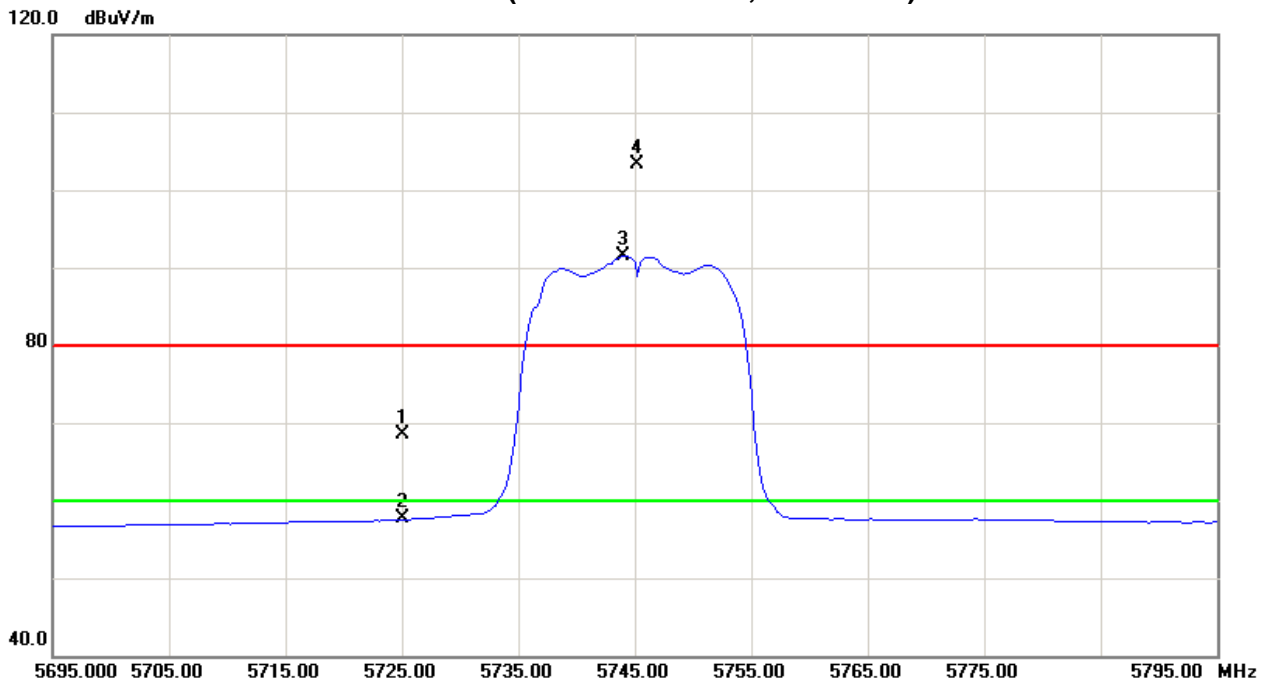



EUT :	Wireless Dual Band Router	Model Name :	WF2471
Temperature :	25 °C	Relative Humidity :	58 %
Pressure :	1010 hPa	Test Voltage :	AC 120V/60Hz
Test Mode :	TX N20 Mode 5785MHz		

Freq. (MHz)	Ant.Pol. H/V	Reading		Ant./CF CF(dB)	Act.		Limit		Note
		Peak (dBuV)	AV (dBuV)		Peak (dBuV/m)	AV (dBuV/m)	Peak (dBuV/m)	AV (dBuV/m)	
5785.75	V	77.25	65.30	42.14	119.39	107.44			X/F
11570.35	V	48.54	38.19	13.36	61.90	51.55	80.00	60.00	X/H

Remark :

- (1) All readings are Peak unless otherwise stated QP in column of 『Note』 . Peak denotes that the Peak reading compliance with the QP Limits and then QP Mode measurement didn't perform ◦
- (2) Measuring frequency range from 30MHz to 1000MHz or the 10th harmonic of highest fundamental frequency ◦ "F" denotes fundamental frequency; "H" denotes spurious frequency. "E" denotes band edge frequency. (This judgment method includes the Band Edge Requirement.)
- (3) Radiated emissions measured in frequency range above 1000MHz were made with an instrument using Peak detector mode and AV detector mode of the emission ◦
- (4) Data of measurement within this frequency range shown " * " in the table above means the reading of emissions are attenuated more than 20dB below the permissible limits or the field strength is too small to be measured.
- (5) A preamp and high pass filter were used for this test in order to provide sufficient measurement sensitivity.
- (6) EUT Orthogonal Axis :
 "X" - denotes Laid on Table ; "Y" - denotes Vertical Stand ; "Z" - denotes Side Stand
- (7) During the measurements above 1 GHz it is taken care of that the EUT is always within the 3 dB cone of radiation BW of the used antenna
- (8) The limits above 5GHz shall be extrapolated to the specified distance using an extrapolation factor of 20dB/decade form 3m to 1.5m
 Distance extrapolation factor = $20 \log (3m/1.5m)$ dB ;
 Limit line = specific limits (dBuV) + 6 dB



TX CH157 (Above 1000 MHz, Vertical)

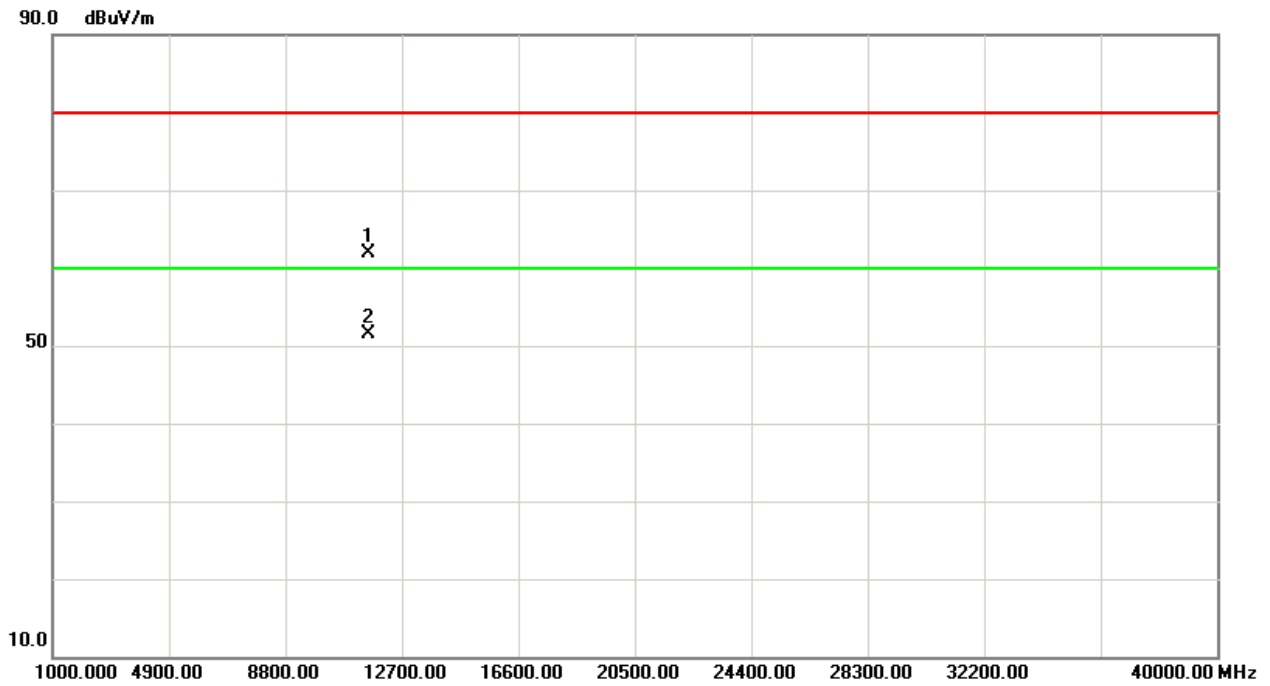
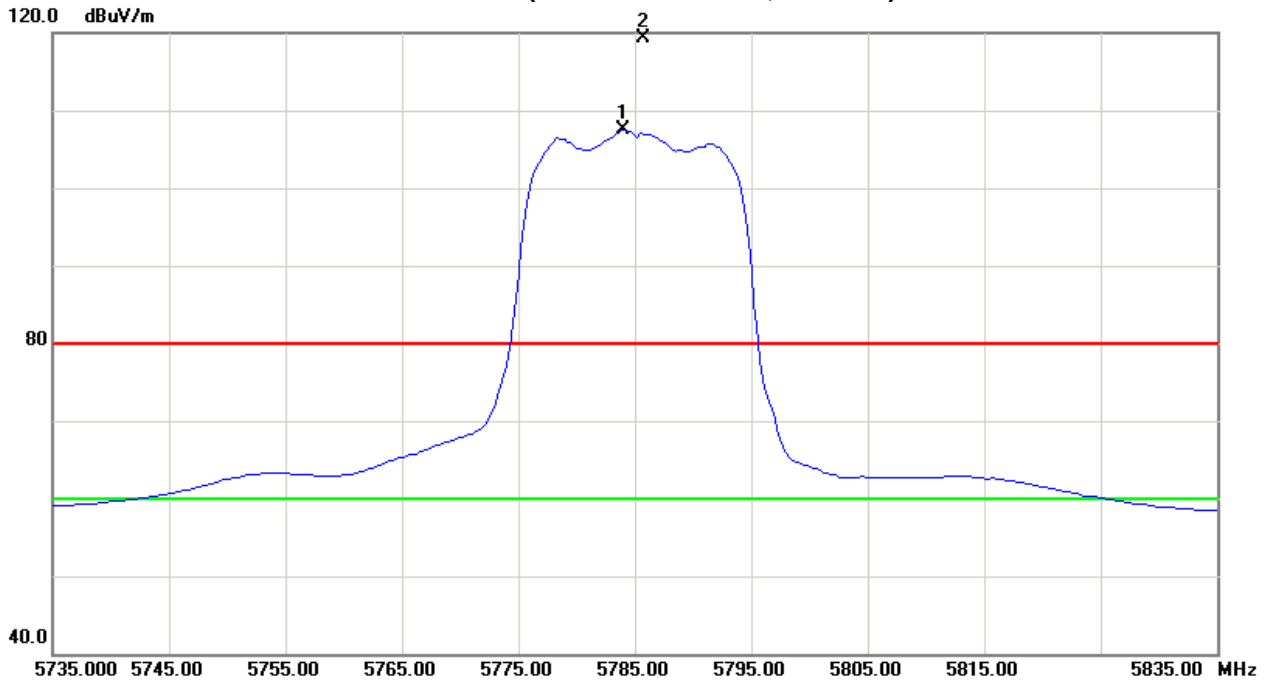



EUT :	Wireless Dual Band Router	Model Name :	WF2471
Temperature :	25 °C	Relative Humidity :	58 %
Pressure :	1010 hPa	Test Voltage :	AC 120V/60Hz
Test Mode :	TX N20 Mode 5785MHz		

Freq. (MHz)	Ant.Pol. HV	Reading		Ant./CF CF(dB)	Act.		Limit		Note
		Peak (dBuV)	AV (dBuV)		Peak (dBuV/m)	AV (dBuV/m)	Peak (dBuV/m)	AV (dBuV/m)	
5783.75	H	60.88	49.16	42.13	103.01	91.29			X/F
11569.88	H	46.59	36.40	13.36	59.95	49.76	80.00	60.00	X/H

Remark :

- (1) All readings are Peak unless otherwise stated QP in column of 『Note』 . Peak denotes that the Peak reading compliance with the QP Limits and then QP Mode measurement didn't perform ◦
- (2) Measuring frequency range from 30MHz to 1000MHz or the 10th harmonic of highest fundamental frequency ◦ "F" denotes fundamental frequency; "H" denotes spurious frequency. "E" denotes band edge frequency. (This judgment method includes the Band Edge Requirement.)
- (3) Radiated emissions measured in frequency range above 1000MHz were made with an instrument using Peak detector mode and AV detector mode of the emission ◦
- (4) Data of measurement within this frequency range shown " * " in the table above means the reading of emissions are attenuated more than 20dB below the permissible limits or the field strength is too small to be measured.
- (5) A preamp and high pass filter were used for this test in order to provide sufficient measurement sensitivity.
- (6) EUT Orthogonal Axis :
 "X" - denotes Laid on Table ; "Y" - denotes Vertical Stand ; "Z" - denotes Side Stand
- (7) During the measurements above 1 GHz it is taken care of that the EUT is always within the 3 dB cone of radiation BW of the used antenna
- (8) The limits above 5GHz shall be extrapolated to the specified distance using an extrapolation factor of 20dB/decade form 3m to 1.5m
 Distance extrapolation factor = 20 log (3m/1.5m) dB ;
 Limit line = specific limits (dBuV) + 6 dB



TX CH157 (Above 1000 MHz, Horizontal)

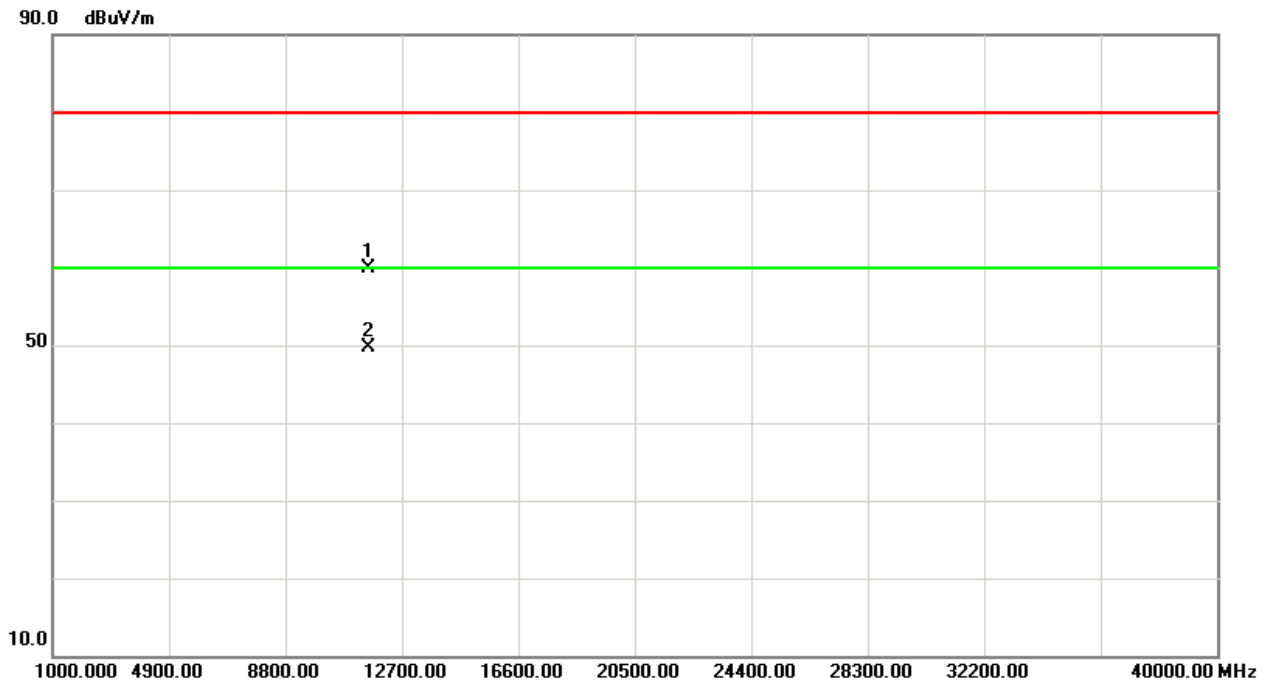
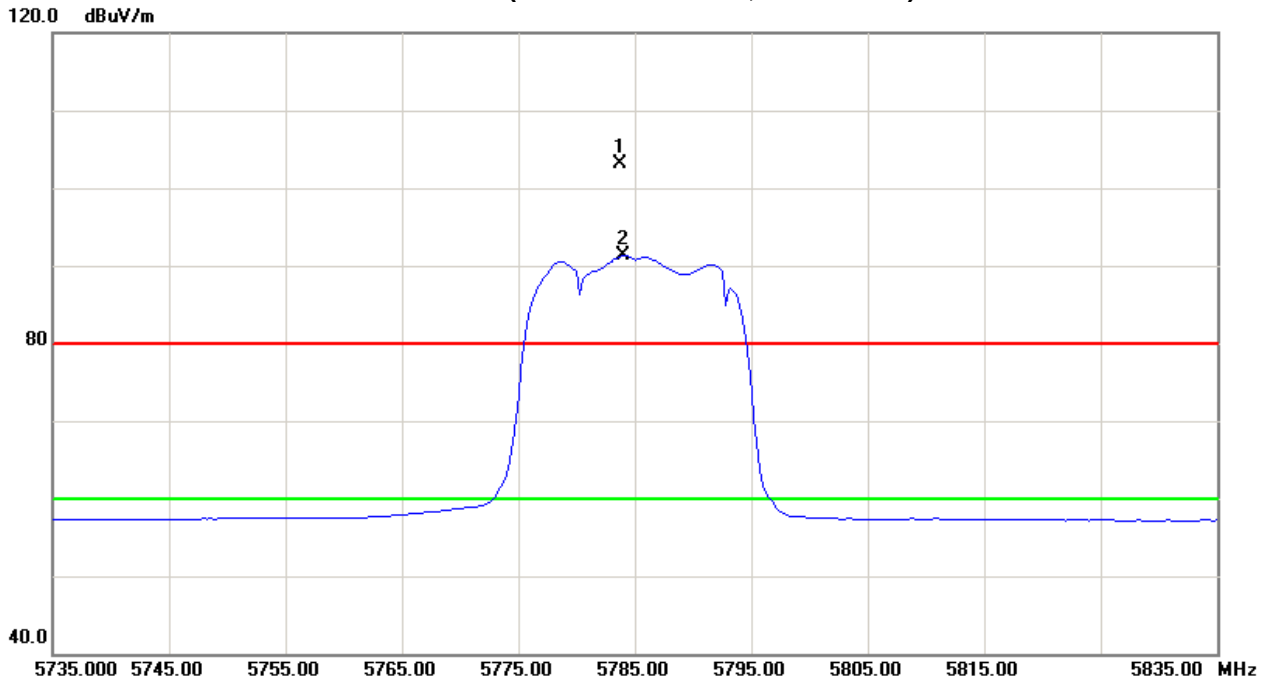



EUT :	Wireless Dual Band Router	Model Name :	WF2471
Temperature :	25 °C	Relative Humidity :	58 %
Pressure :	1010 hPa	Test Voltage :	AC 120V/60Hz
Test Mode :	TX N20 Mode 5825MHz		

Freq.	Ant.Pol.	Reading		Ant./CF	Act.		Limit		Note
		Peak	AV		Peak	AV	Peak	AV	
(MHz)	H/V	(dBuV)	(dBuV)	CF(dB)	(dBuV/m)	(dBuV/m)	(dBuV/m)	(dBuV/m)	
5824.00	V	77.52	64.72	42.29	119.81	107.01			X/F
# 5850.00	V	36.71	20.25	42.40	79.11	62.65	80.00	87.01	X/E
11650.20	V	48.53	38.05	13.43	61.96	51.48	80.00	60.00	X/H

Remark :

- (1) All readings are Peak unless otherwise stated QP in column of 『Note』 . Peak denotes that the Peak reading compliance with the QP Limits and then QP Mode measurement didn't perform ◦
- (2) Measuring frequency range from 30MHz to 1000MHz or the 10th harmonic of highest fundamental frequency ◦ "F" denotes fundamental frequency; "H" denotes spurious frequency. "E" denotes band edge frequency. (This judgment method includes the Band Edge Requirement.)
- (3) Radiated emissions measured in frequency range above 1000MHz were made with an instrument using Peak detector mode and AV detector mode of the emission ◦
- (4) Data of measurement within this frequency range shown " * " in the table above means the reading of emissions are attenuated more than 20dB below the permissible limits or the field strength is too small to be measured.
- (5) A preamp and high pass filter were used for this test in order to provide sufficient measurement sensitivity.
- (6) EUT Orthogonal Axis :
 "X" - denotes Laid on Table ; "Y" - denotes Vertical Stand ; "Z" - denotes Side Stand
- (7) During the measurements above 1 GHz it is taken care of that the EUT is always within the 3 dB cone of radiation BW of the used antenna
- (8) The limits above 5GHz shall be extrapolated to the specified distance using an extrapolation factor of 20dB/decade form 3m to 1.5m
 Distance extrapolation factor = $20 \log (3m/1.5m)$ dB ;
 Limit line = specific limits (dBuV) + 6 dB
- (9) "#" The radiated frequency is out of the restricted band. Limit line= fundamental - 20dB



TX CH165 (Above 1000 MHz, Vertical)

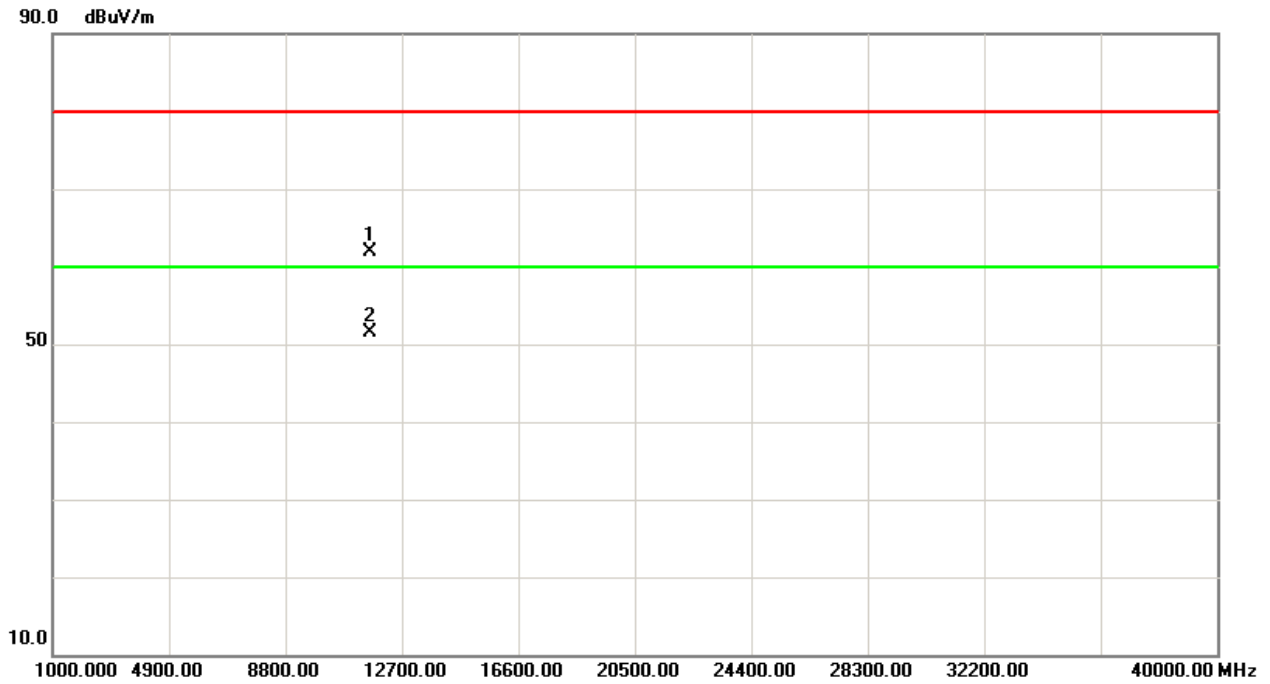
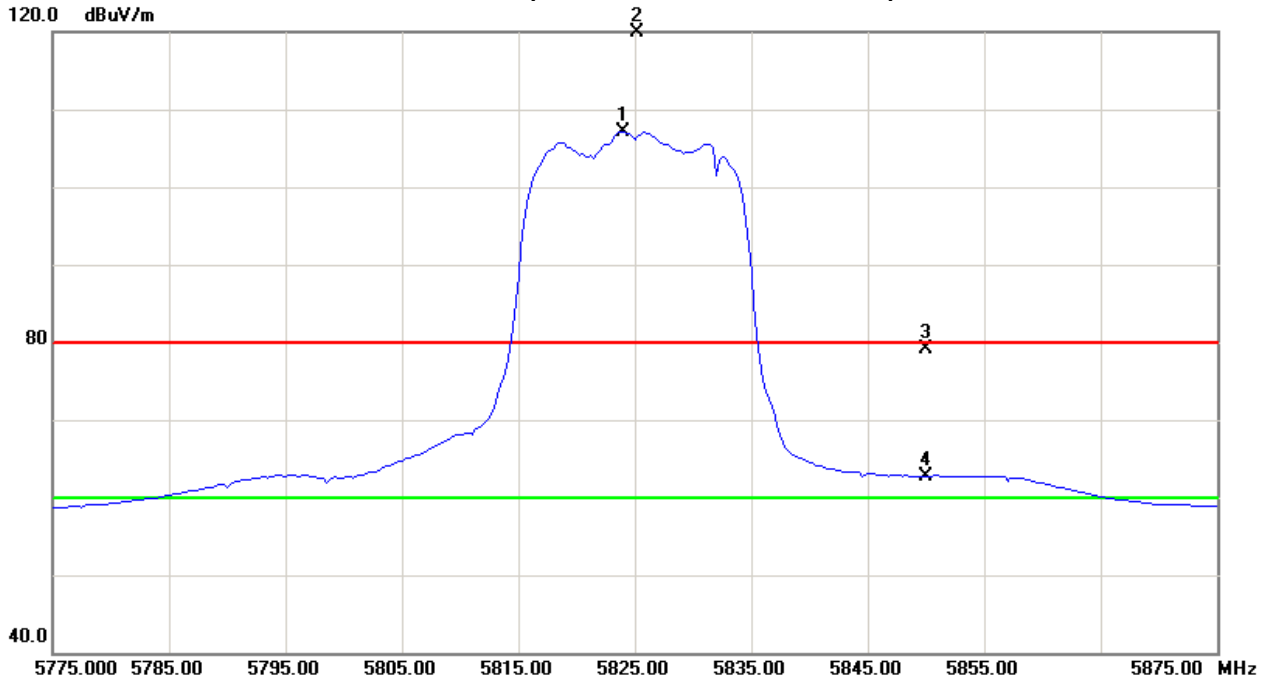



EUT :	Wireless Dual Band Router	Model Name :	WF2471
Temperature :	25 °C	Relative Humidity :	58 %
Pressure :	1010 hPa	Test Voltage :	AC 120V/60Hz
Test Mode :	TX N20Mode 5825MHz		

Freq.	Ant.Pol.	Reading		Ant./CF	Act.		Limit		Note
		Peak	AV		Peak	AV	Peak	AV	
(MHz)	H/V	(dBuV)	(dBuV)	CF(dB)	(dBuV/m)	(dBuV/m)	(dBuV/m)	(dBuV/m)	
5826.50	H	61.33	48.86	42.31	103.64	91.17			X/F
# 5850.00	H	25.54	15.13	42.40	67.94	57.53	83.64	71.17	X/E
11650.12	H	46.37	36.09	13.43	59.80	49.52	80.00	60.00	X/H

Remark :

- (1) All readings are Peak unless otherwise stated QP in column of 『Note』 . Peak denotes that the Peak reading compliance with the QP Limits and then QP Mode measurement didn't perform ◦
- (2) Measuring frequency range from 30MHz to 1000MHz or the 10th harmonic of highest fundamental frequency ◦ "F" denotes fundamental frequency; "H" denotes spurious frequency. "E" denotes band edge frequency. (This judgment method includes the Band Edge Requirement.)
- (3) Radiated emissions measured in frequency range above 1000MHz were made with an instrument using Peak detector mode and AV detector mode of the emission ◦
- (4) Data of measurement within this frequency range shown " * " in the table above means the reading of emissions are attenuated more than 20dB below the permissible limits or the field strength is too small to be measured.
- (5) A preamp and high pass filter were used for this test in order to provide sufficient measurement sensitivity.
- (6) EUT Orthogonal Axis :
 "X" - denotes Laid on Table ; "Y" - denotes Vertical Stand ; "Z" - denotes Side Stand
- (7) During the measurements above 1 GHz it is taken care of that the EUT is always within the 3 dB cone of radiation BW of the used antenna
- (8) The limits above 5GHz shall be extrapolated to the specified distance using an extrapolation factor of 20dB/decade form 3m to 1.5m
 Distance extrapolation factor = 20 log (3m/1.5m) dB ;
 Limit line = specific limits (dBuV) + 6 dB
- (9) "# " The radiated frequency is out of the restricted band. Limit line= fundamental - 20dB



TX CH165 (Above 1000 MHz, Horizontal)

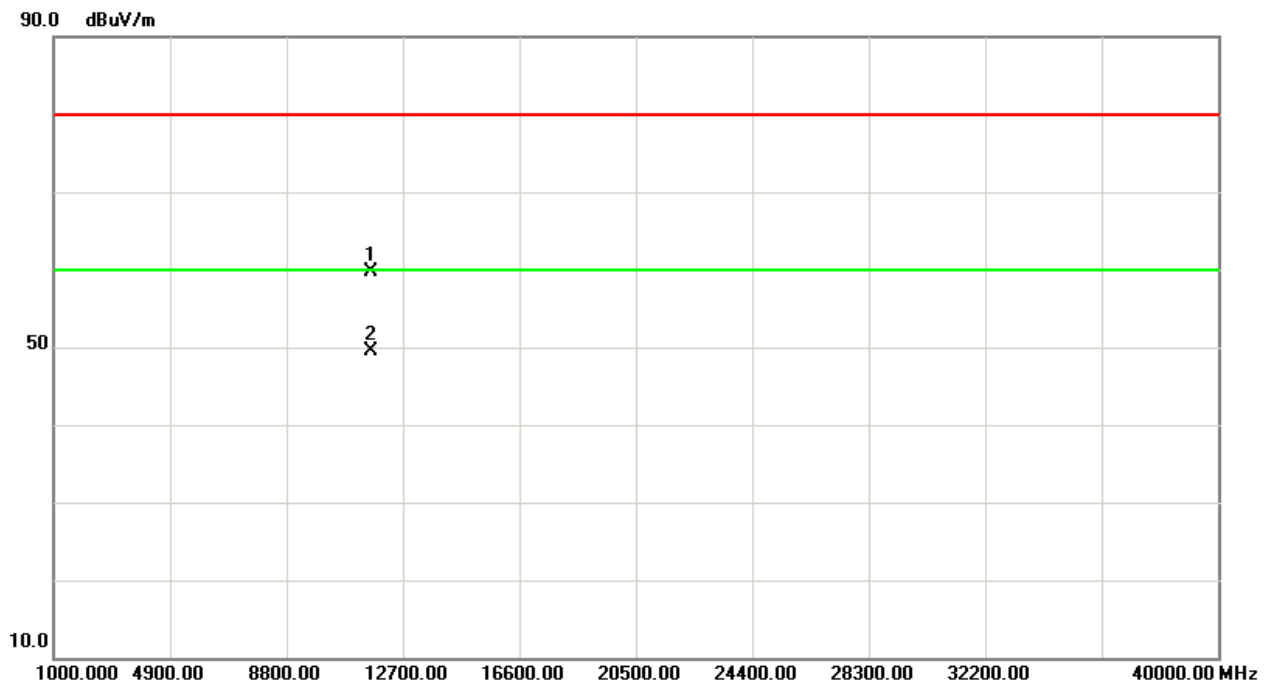
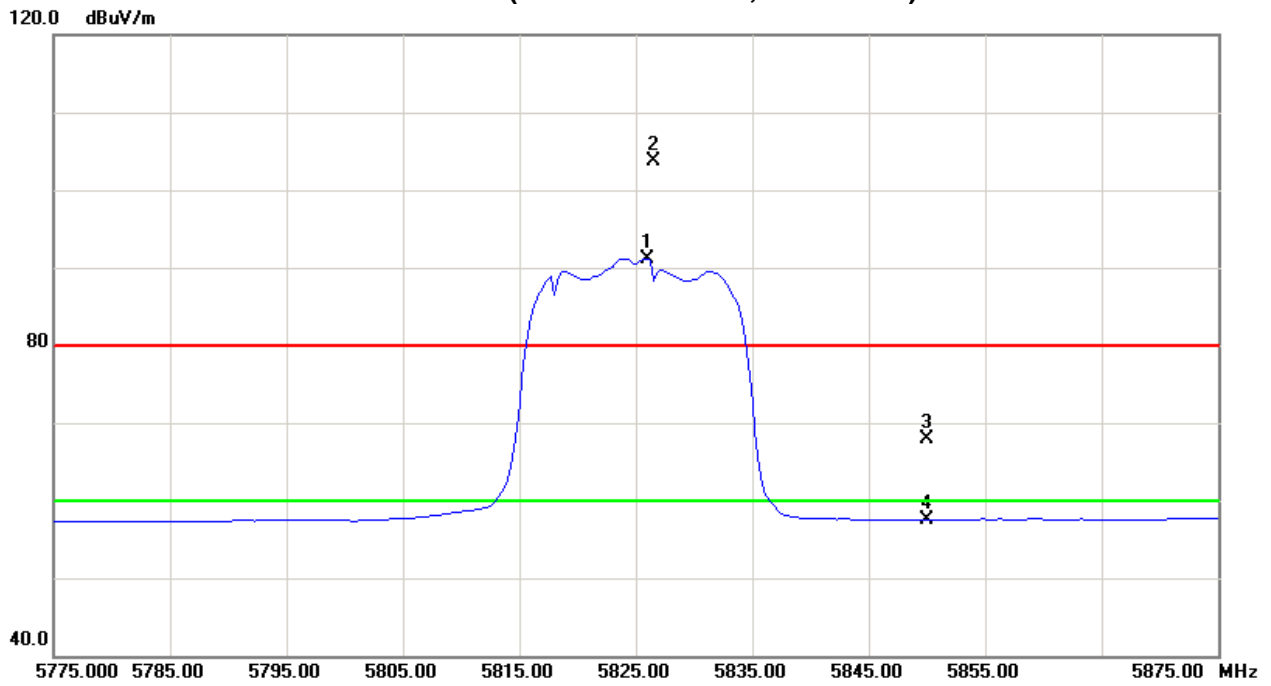



EUT :	Wireless Dual Band Router	Model Name :	WF2471
Temperature :	25 °C	Relative Humidity :	58 %
Pressure :	1010 hPa	Test Voltage :	AC 120V/60Hz
Test Mode :	TX N40 Mode 5755MHz		

Freq. (MHz)	Ant.Pol. H/V	Reading		Ant./CF CF(dB)	Act.		Limit		Note
		Peak (dBuV)	AV (dBuV)		Peak (dBuV/m)	AV (dBuV/m)	Peak (dBuV/m)	AV (dBuV/m)	
# 5725.00	V	42.87	24.17	41.90	84.77	66.07	94.49	81.66	X/E
5753.50	V	72.48	59.65	42.01	114.49	101.66			X/F
11510.28	V	46.39	35.72	13.30	59.69	49.02	80.00	60.00	X/H

Remark :

- (1) All readings are Peak unless otherwise stated QP in column of 『Note』 . Peak denotes that the Peak reading compliance with the QP Limits and then QP Mode measurement didn't perform ◦
- (2) Measuring frequency range from 30MHz to 1000MHz or the 10th harmonic of highest fundamental frequency ◦ "F" denotes fundamental frequency; "H" denotes spurious frequency. "E" denotes band edge frequency. (This judgment method includes the Band Edge Requirement.)
- (3) Radiated emissions measured in frequency range above 1000MHz were made with an instrument using Peak detector mode and AV detector mode of the emission ◦
- (4) Data of measurement within this frequency range shown " * " in the table above means the reading of emissions are attenuated more than 20dB below the permissible limits or the field strength is too small to be measured.
- (5) A preamp and high pass filter were used for this test in order to provide sufficient measurement sensitivity.
- (6) EUT Orthogonal Axis :
 "X" - denotes Laid on Table ; "Y" - denotes Vertical Stand ; "Z" - denotes Side Stand
- (7) During the measurements above 1 GHz it is taken care of that the EUT is always within the 3 dB cone of radiation BW of the used antenna
- (8) The limits above 5GHz shall be extrapolated to the specified distance using an extrapolation factor of 20dB/decade form 3m to 1.5m
 Distance extrapolation factor = $20 \log (3m/1.5m)$ dB ;
 Limit line = specific limits (dBuV) + 6 dB
- (9) "#" The radiated frequency is out of the restricted band. Limit line= fundamental - 20dB



TX CH151 (Above 1000 MHz, Vertical)

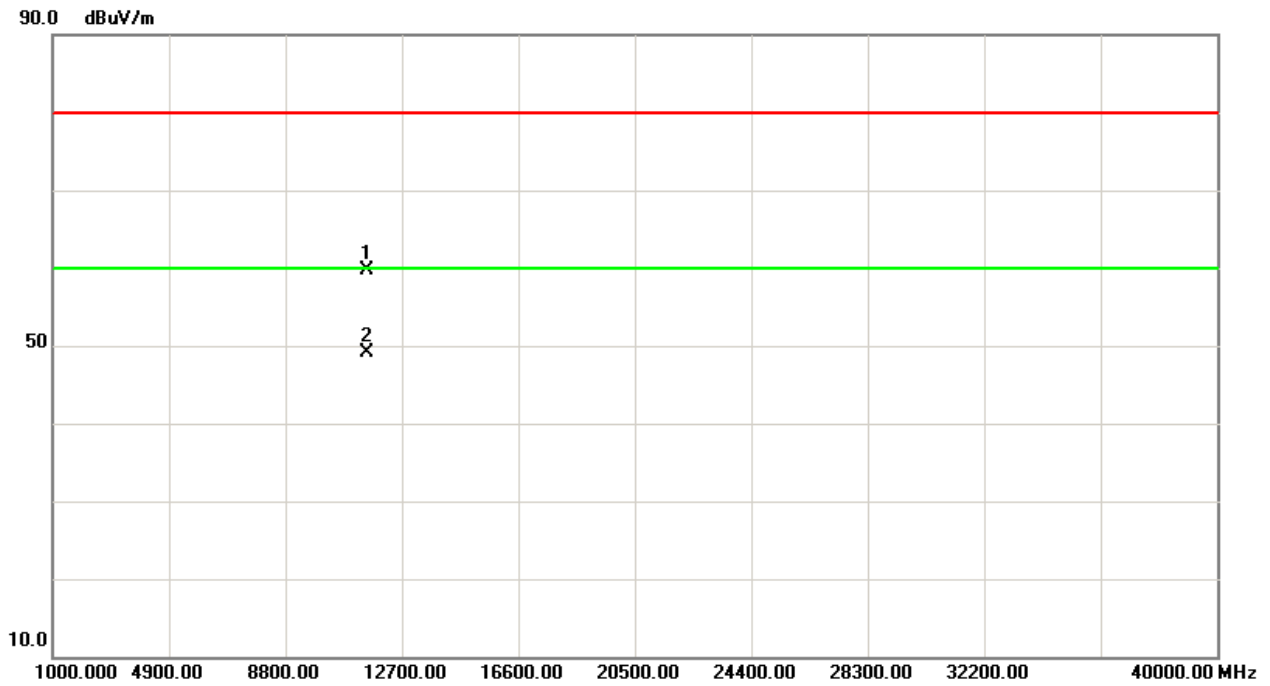
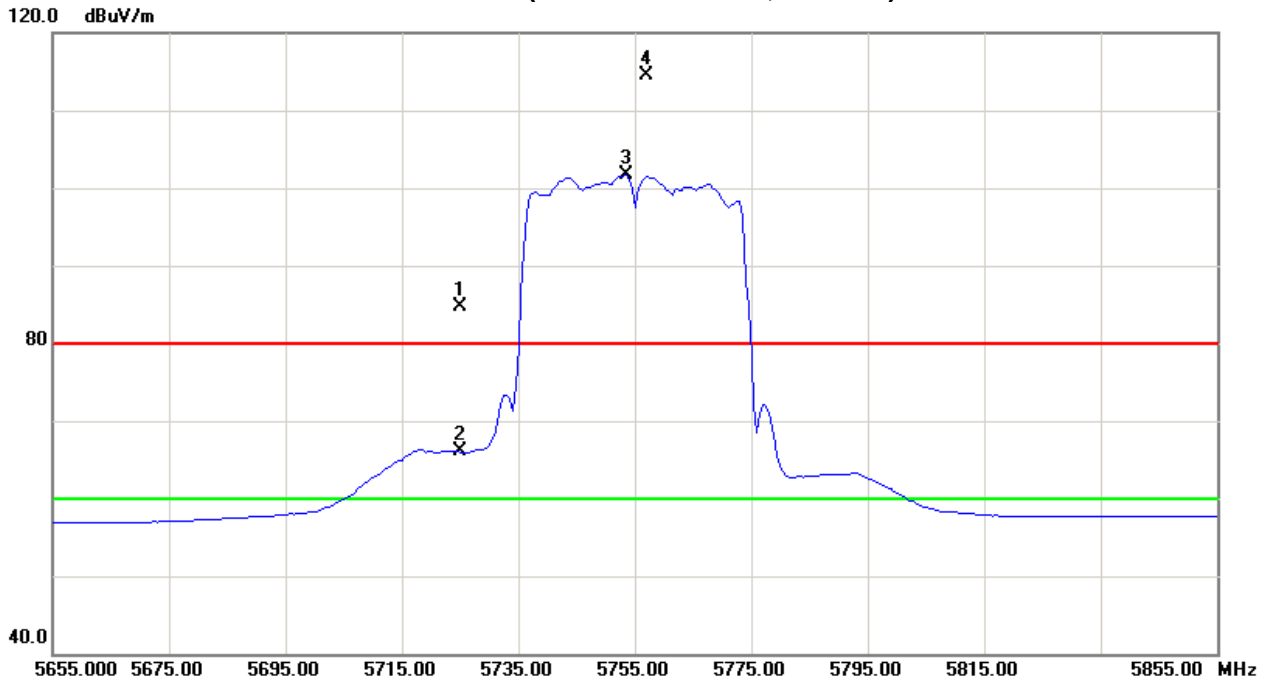



EUT :	Wireless Dual Band Router	Model Name :	WF2471
Temperature :	25 °C	Relative Humidity :	58 %
Pressure :	1010 hPa	Test Voltage :	AC 120V/60Hz
Test Mode :	TX N40 Mode 5755MHz		

Freq. (MHz)	Ant.Pol. H/V	Reading		Ant./CF CF(dB)	Act.		Limit		Note
		Peak (dBuV)	AV (dBuV)		Peak (dBuV/m)	AV (dBuV/m)	Peak (dBuV/m)	AV (dBuV/m)	
# 5725.00	H	25.62	15.71	41.90	67.52	57.61	77.01	65.49	X/E
5752.50	H	55.00	43.48	42.01	97.01	85.49			X/F
11509.96	H	44.75	33.85	13.30	58.05	47.15	80.00	60.00	X/H

Remark :

- (1) All readings are Peak unless otherwise stated QP in column of 『Note』 . Peak denotes that the Peak reading compliance with the QP Limits and then QP Mode measurement didn't perform ◦
- (2) Measuring frequency range from 30MHz to 1000MHz or the 10th harmonic of highest fundamental frequency ◦ "F" denotes fundamental frequency; "H" denotes spurious frequency. "E" denotes band edge frequency. (This judgment method includes the Band Edge Requirement.)
- (3) Radiated emissions measured in frequency range above 1000MHz were made with an instrument using Peak detector mode and AV detector mode of the emission ◦
- (4) Data of measurement within this frequency range shown " * " in the table above means the reading of emissions are attenuated more than 20dB below the permissible limits or the field strength is too small to be measured.
- (5) A preamp and high pass filter were used for this test in order to provide sufficient measurement sensitivity.
- (6) EUT Orthogonal Axis :
"X" - denotes Laid on Table ; "Y" - denotes Vertical Stand ; "Z" - denotes Side Stand
- (7) During the measurements above 1 GHz it is taken care of that the EUT is always within the 3 dB cone of radiation BW of the used antenna
- (8) The limits above 5GHz shall be extrapolated to the specified distance using an extrapolation factor of 20dB/decade form 3m to 1.5m
Distance extrapolation factor = 20 log (3m/1.5m) dB ;
Limit line = specific limits (dBuV) + 6 dB
- (9) "#" The radiated frequency is out of the restricted band. Limit line= fundamental - 20dB



TX CH151 (Above 1000 MHz, Horizontal)

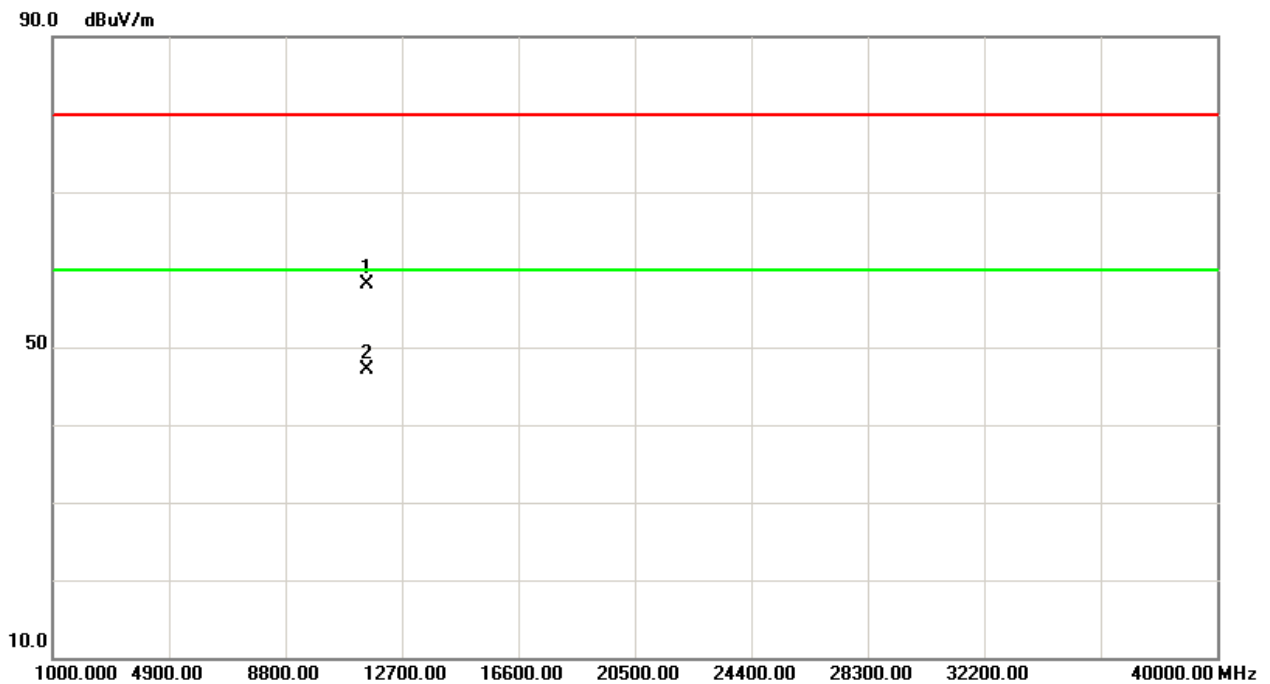
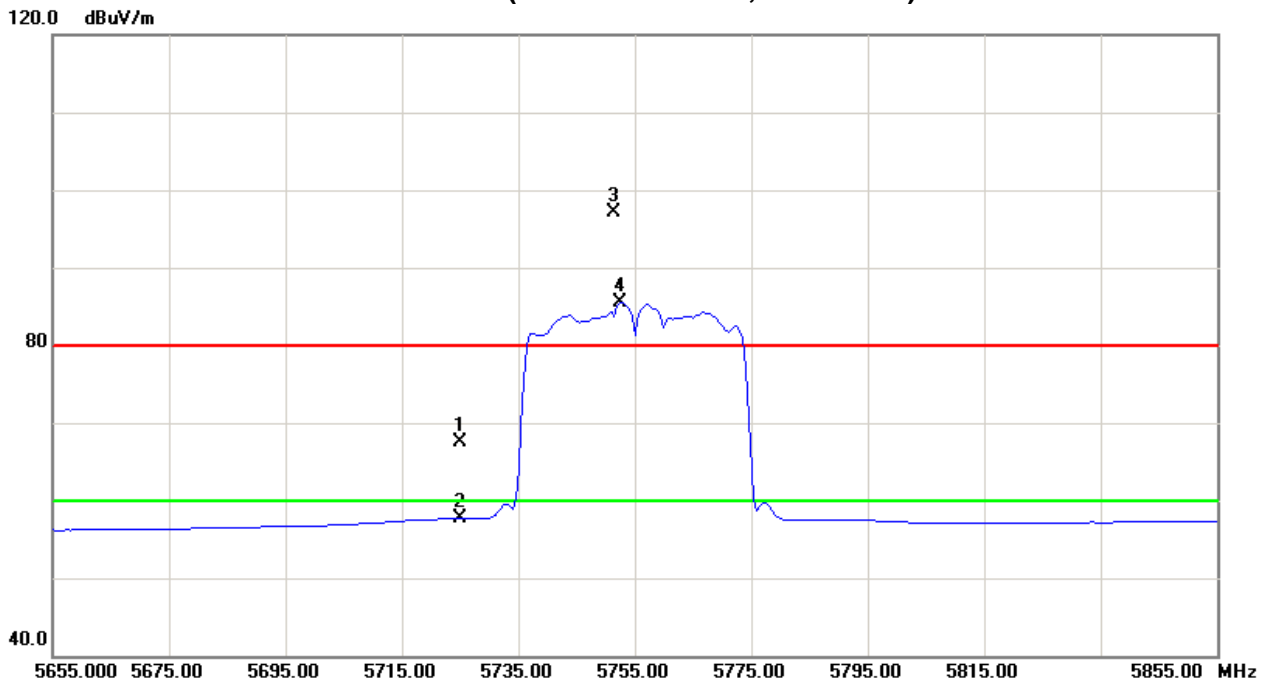



EUT :	Wireless Dual Band Router	Model Name :	WF2471
Temperature :	25 °C	Relative Humidity :	58 %
Pressure :	1010 hPa	Test Voltage :	AC 120V/60Hz
Test Mode :	TX N40 Mode 5795MHz		

Freq.	Ant.Pol.	Reading		Ant./CF	Act.		Limit		Note
		Peak	AV		Peak	AV	Peak	AV	
(MHz)	H/V	(dBuV)	(dBuV)	CF(dB)	(dBuV/m)	(dBuV/m)	(dBuV/m)	(dBuV/m)	
5797.00	V	71.97	59.10	42.19	114.16	101.29			X/F
# 5850.00	V	27.11	16.09	42.40	69.51	58.49	94.16	81.29	X/E
11589.75	V	46.45	35.08	13.38	59.83	48.46	80.00	60.00	X/H

Remark :

- (1) All readings are Peak unless otherwise stated QP in column of 『Note』 . Peak denotes that the Peak reading compliance with the QP Limits and then QP Mode measurement didn't perform ◦
- (2) Measuring frequency range from 30MHz to 1000MHz or the 10th harmonic of highest fundamental frequency ◦ "F" denotes fundamental frequency; "H" denotes spurious frequency. "E" denotes band edge frequency. (This judgment method includes the Band Edge Requirement.)
- (3) Radiated emissions measured in frequency range above 1000MHz were made with an instrument using Peak detector mode and AV detector mode of the emission ◦
- (4) Data of measurement within this frequency range shown " * " in the table above means the reading of emissions are attenuated more than 20dB below the permissible limits or the field strength is too small to be measured.
- (5) A preamp and high pass filter were used for this test in order to provide sufficient measurement sensitivity.
- (6) EUT Orthogonal Axis :
 "X" - denotes Laid on Table ; "Y" - denotes Vertical Stand ; "Z" - denotes Side Stand
- (7) During the measurements above 1 GHz it is taken care of that the EUT is always within the 3 dB cone of radiation BW of the used antenna
- (8) The limits above 5GHz shall be extrapolated to the specified distance using an extrapolation factor of 20dB/decade form 3m to 1.5m
 Distance extrapolation factor = 20 log (3m/1.5m) dB ;
 Limit line = specific limits (dBuV) + 6 dB
- (9) "# " The radiated frequency is out of the restricted band. Limit line= fundamental - 20dB



TX CH159 (Above 1000 MHz, Vertical)

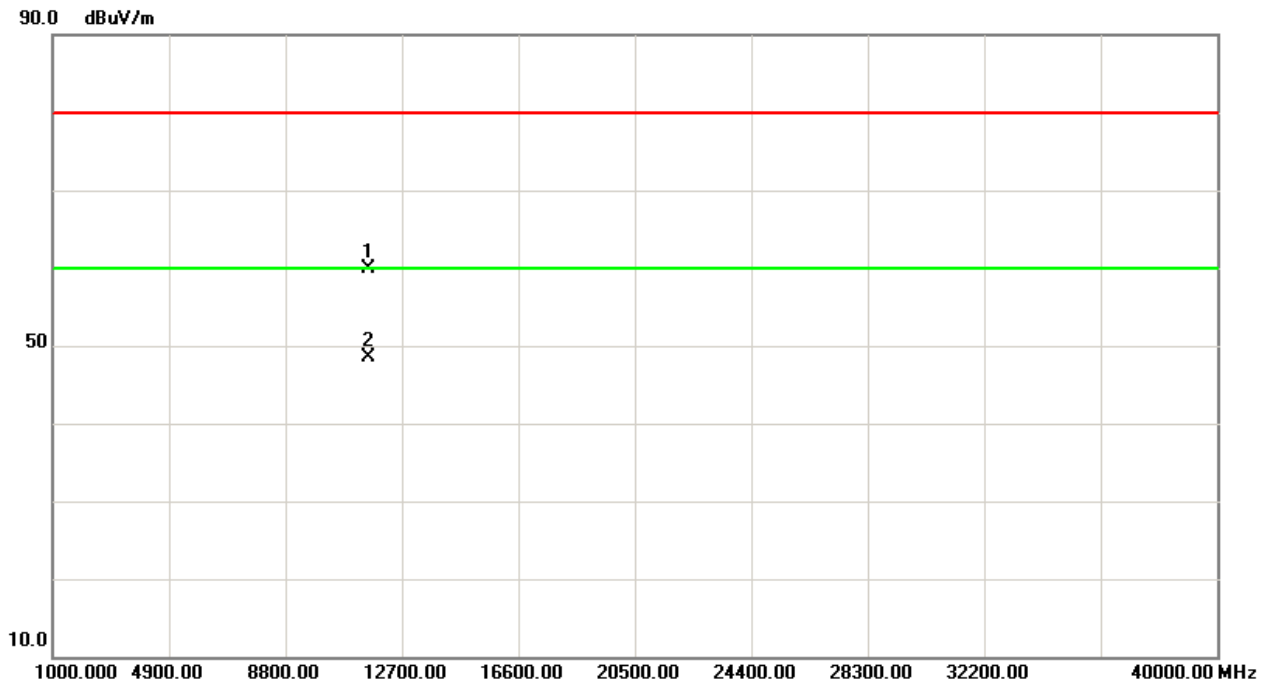
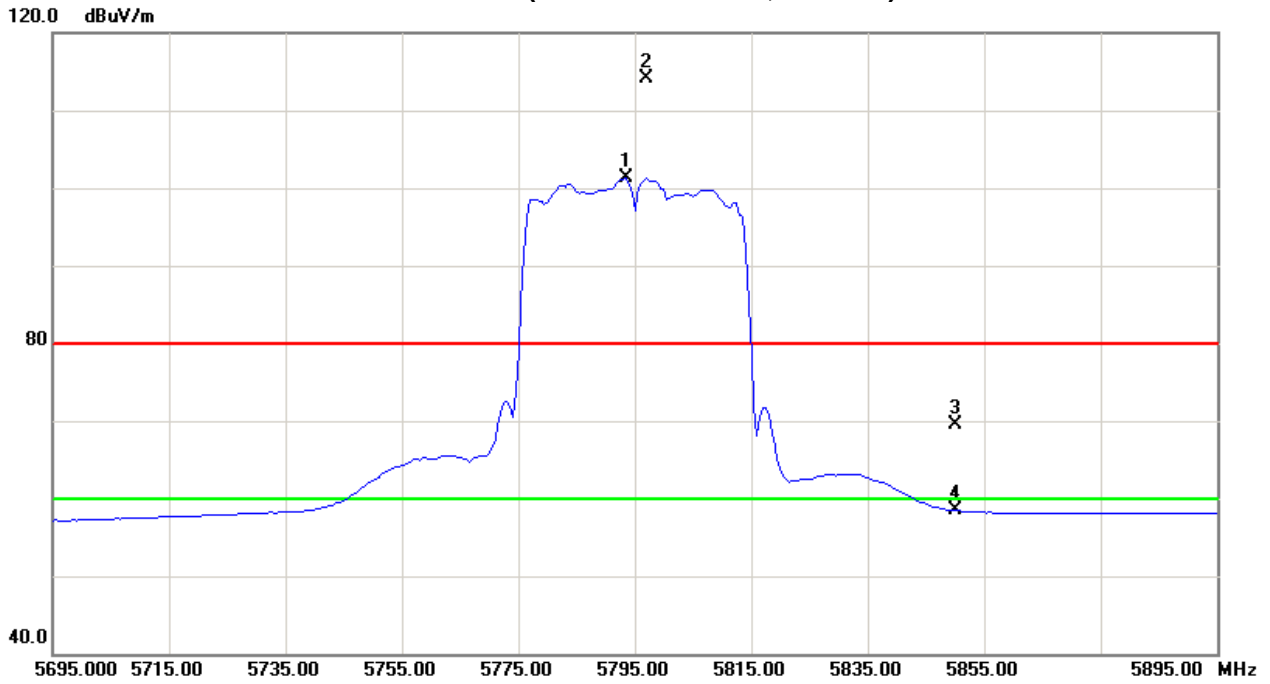



EUT :	Wireless Dual Band Router	Model Name :	WF2471
Temperature :	25 °C	Relative Humidity :	58 %
Pressure :	1010 hPa	Test Voltage :	AC 120V/60Hz
Test Mode :	TX N40 Mode 5795MHz		

Freq.	Ant.Pol.	Reading		Ant./CF	Act.		Limit		Note
		Peak	AV		Peak	AV	Peak	AV	
(MHz)	H/V	(dBuV)	(dBuV)	CF(dB)	(dBuV/m)	(dBuV/m)	(dBuV/m)	(dBuV/m)	
5797.00	H	55.90	44.07	42.19	98.09	86.26			X/F
# 5850.00	H	25.33	14.91	42.40	67.73	57.31	78.09	66.26	X/E
11590.26	H	44.50	33.65	13.38	57.88	47.03	80.00	60.00	X/H

Remark :

- (1) All readings are Peak unless otherwise stated QP in column of 『Note』 . Peak denotes that the Peak reading compliance with the QP Limits and then QP Mode measurement didn't perform ◦
- (2) Measuring frequency range from 30MHz to 1000MHz or the 10th harmonic of highest fundamental frequency ◦ "F" denotes fundamental frequency; "H" denotes spurious frequency. "E" denotes band edge frequency. (This judgment method includes the Band Edge Requirement.)
- (3) Radiated emissions measured in frequency range above 1000MHz were made with an instrument using Peak detector mode and AV detector mode of the emission ◦
- (4) Data of measurement within this frequency range shown " * " in the table above means the reading of emissions are attenuated more than 20dB below the permissible limits or the field strength is too small to be measured.
- (5) A preamp and high pass filter were used for this test in order to provide sufficient measurement sensitivity.
- (6) EUT Orthogonal Axis :
 "X" - denotes Laid on Table ; "Y" - denotes Vertical Stand ; "Z" - denotes Side Stand
- (7) During the measurements above 1 GHz it is taken care of that the EUT is always within the 3 dB cone of radiation BW of the used antenna
- (8) The limits above 5GHz shall be extrapolated to the specified distance using an extrapolation factor of 20dB/decade form 3m to 1.5m
 Distance extrapolation factor = $20 \log (3m/1.5m)$ dB ;
 Limit line = specific limits (dBuV) + 6 dB
- (9) "#" The radiated frequency is out of the restricted band. Limit line= fundamental - 20dB



TX CH159 (Above 1000 MHz, Horizontal)

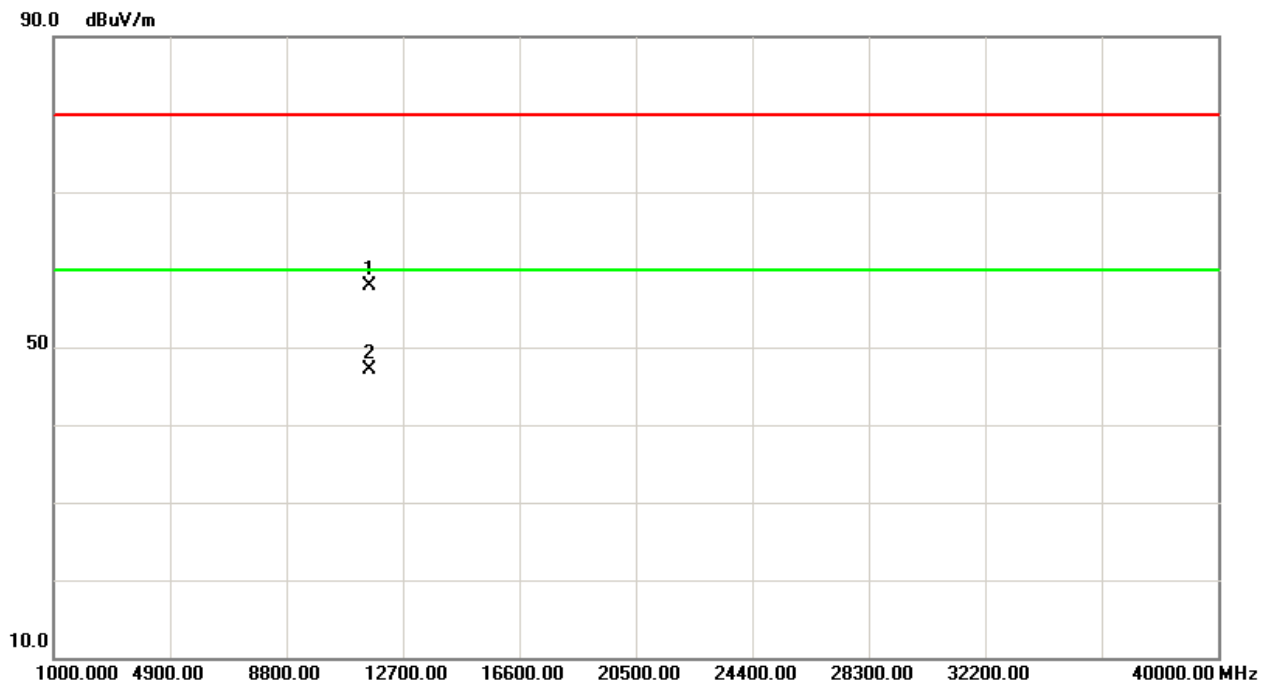
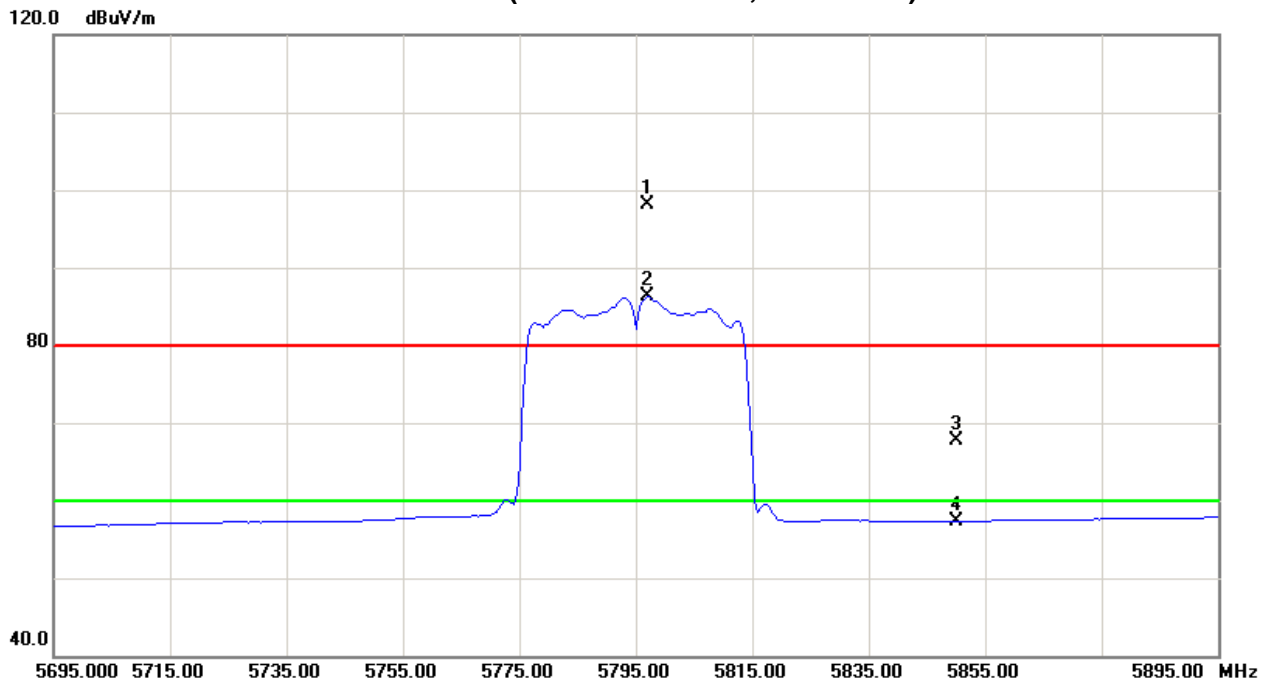



5. BANDWIDTH TEST

5.1 Applied procedures / limit

FCC Part15 (15.247) , Subpart C				
Section	Test Item	Limit	Frequency Range (MHz)	Result
15.247(a)(2)	Bandwidth	$\geq 500\text{KHz}$ (6dB bandwidth)	5725 - 5825	PASS

5.1.1 MEASUREMENT INSTRUMENTS LIST

Item	Kind of Equipment	Manufacturer	Type No.	Serial No.	Last Calibration	Next Calibration
1	Spectrum Analyzer	R&S	FSP_40	100185	Nov.25.2012	Nov.16.2013

Remark: "N/A" denotes no model name, serial no. or calibration specified.
All calibration period of Equipment List is One Year.

5.1.2 TEST PROCEDURE

- a. The EUT was directly connected to the spectrum analyzer and antenna output port as show in the block diagram below,
- b. Spectrum Setting : RBW= 300KHz, VBW=1MHz, Sweep time = 20 ms.

5.1.3 DEVIATION FROM STANDARD

No deviation.

5.1.4 TEST SETUP



5.1.5 EUT OPERATION CONDITIONS

The EUT tested system was configured as the statements of 4.1.6 Unless otherwise a special operating condition is specified in the follows during the testing.



5.1.6 TEST RESULTS

EUT :	Wireless Dual Band Router	Model Name. :	WF2471
Temperature :	25 °C	Relative Humidity :	58 %
Pressure :	1010 hPa	Test Voltage :	AC 120V/60Hz
Test Mode :	TX A Mode /CH149, CH157, CH165		

Test Channel	Frequency (MHz)	6dB Bandwidth (MHz)	LIMIT (MHz)
CH149	5745	16.00	>=500KHz
CH157	5785	16.04	>=500KHz
CH165	5825	16.08	>=500KHz

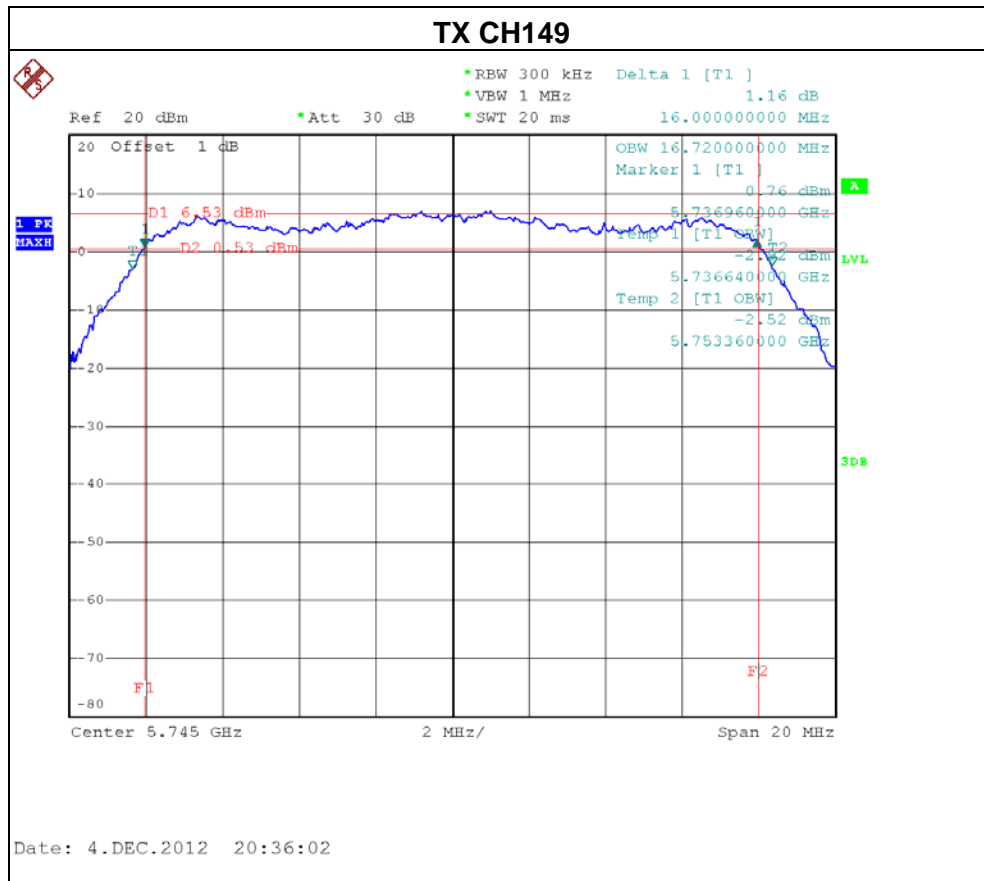

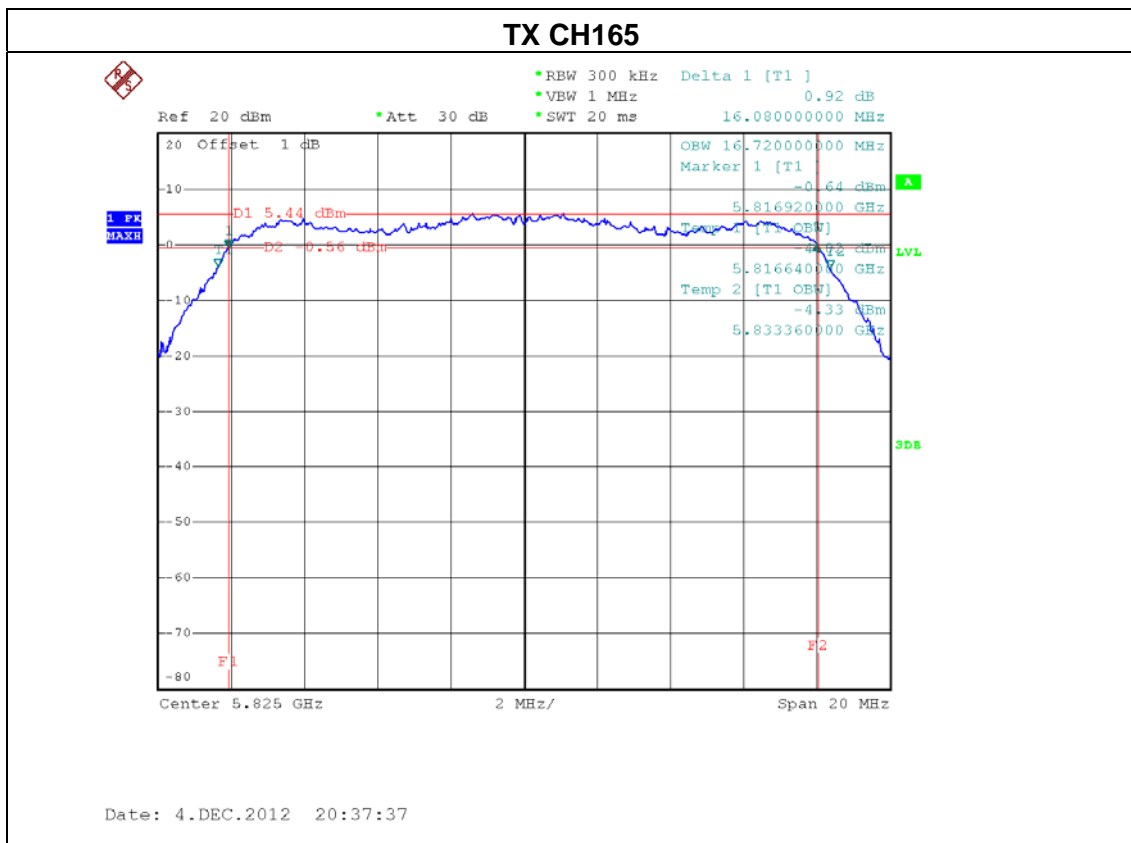
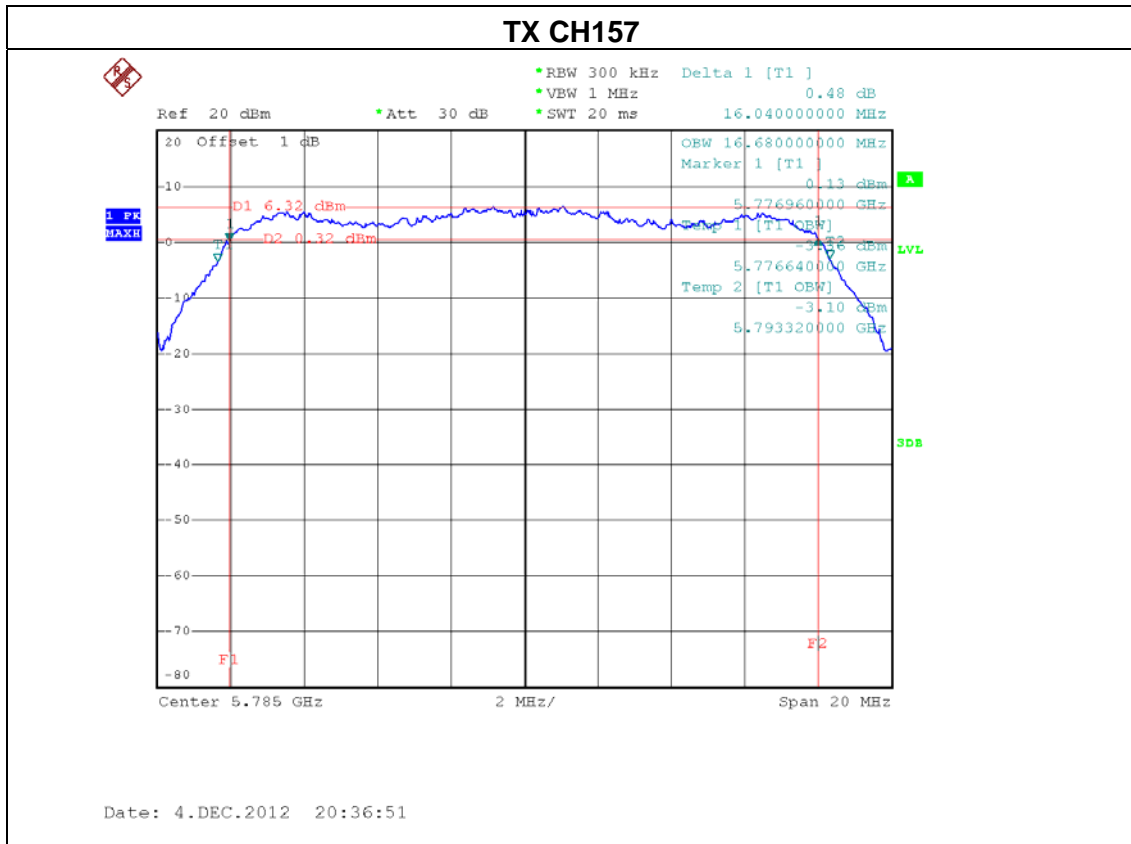



EUT :	Wireless Dual Band Router	Model Name. :	WF2471
Temperature :	25 °C	Relative Humidity :	58 %
Pressure :	1010 hPa	Test Voltage :	AC 120V/60Hz
Test Mode :	TX N20 Mode /CH149, CH157, CH165 -ANT 1		

Test Channel	Frequency (MHz)	6dB Bandwidth (MHz)	LIMIT (MHz)
CH149	5745	17.00	>=500KHz
CH157	5785	17.08	>=500KHz
CH165	5825	17.12	>=500KHz

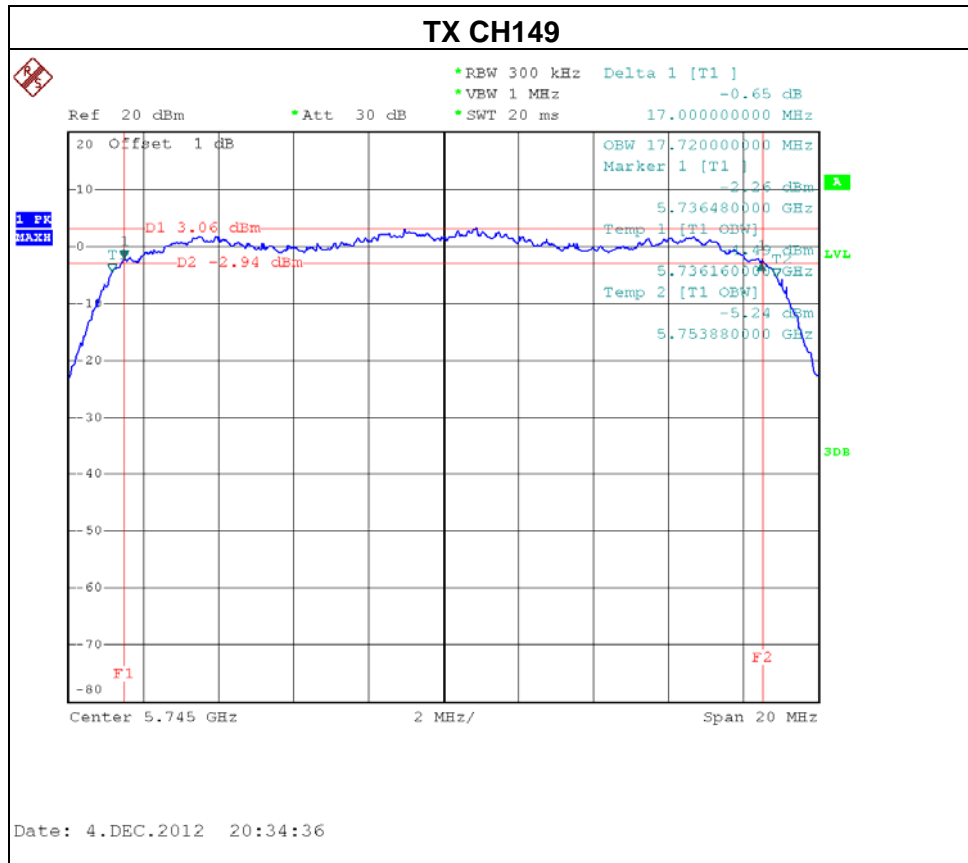

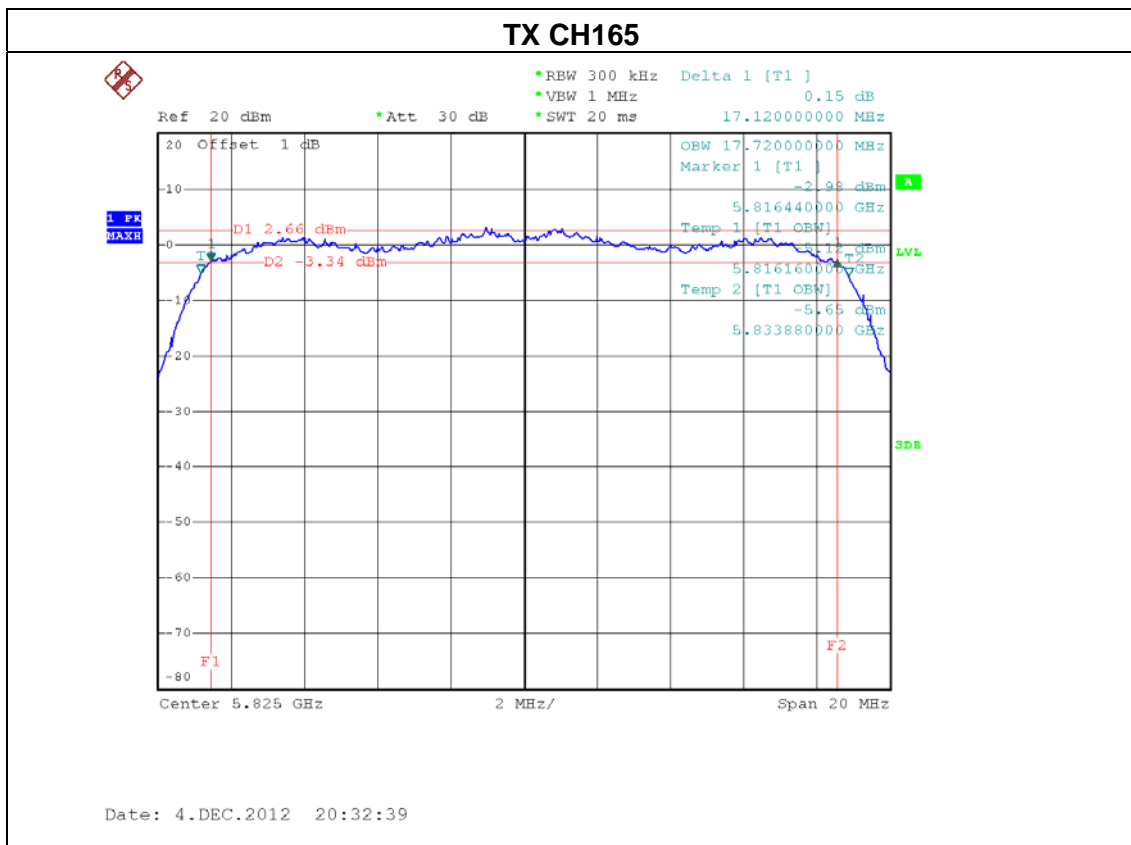
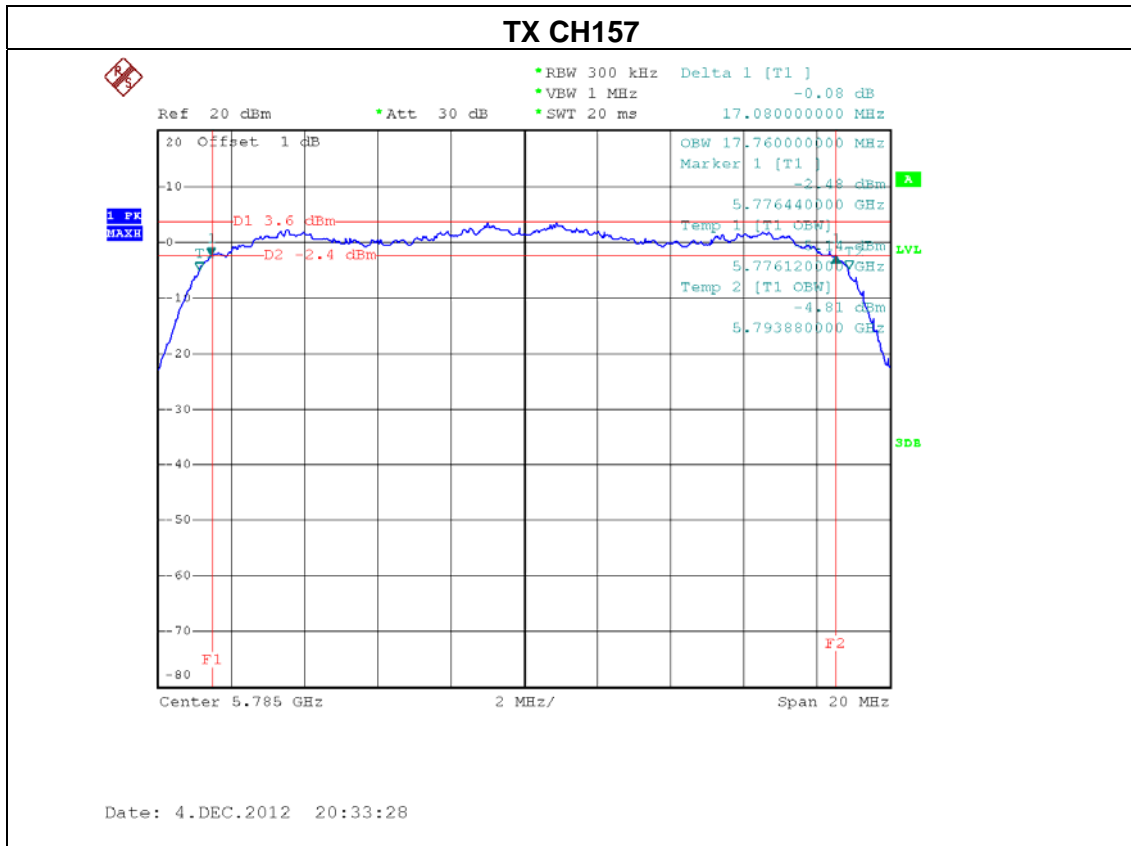



EUT :	Wireless Dual Band Router	Model Name. :	WF2471
Temperature :	25 °C	Relative Humidity :	58 %
Pressure :	1010 hPa	Test Voltage :	AC 120V/60Hz
Test Mode :	TX N20 Mode /CH149, CH157, CH165 -ANT 2		

Test Channel	Frequency (MHz)	6dB Bandwidth (MHz)	LIMIT (MHz)
CH149	5745	17.20	>=500KHz
CH157	5785	17.04	>=500KHz
CH165	5825	17.08	>=500KHz

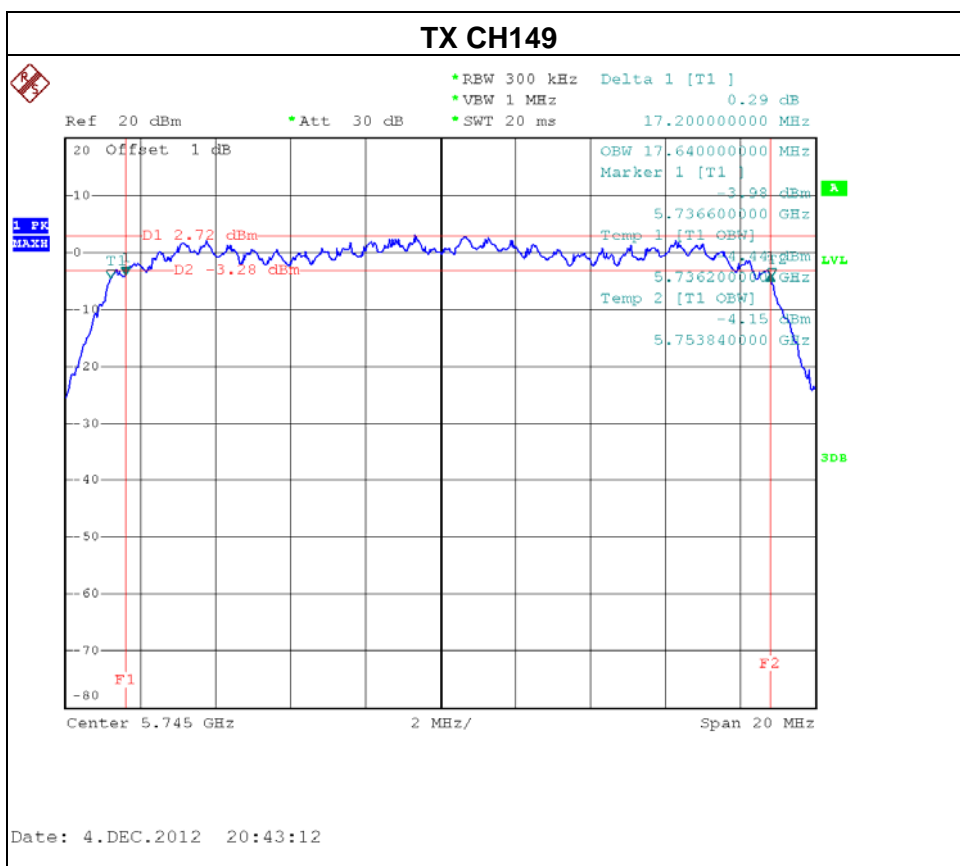

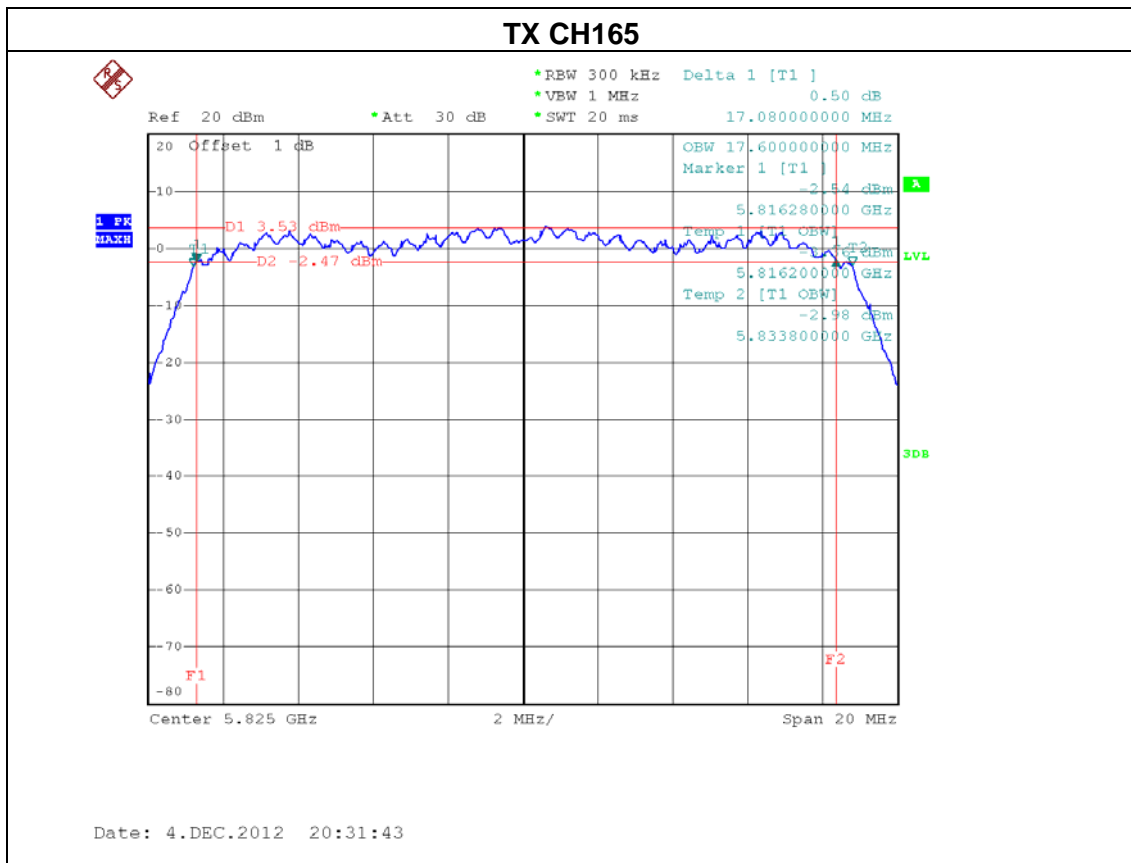
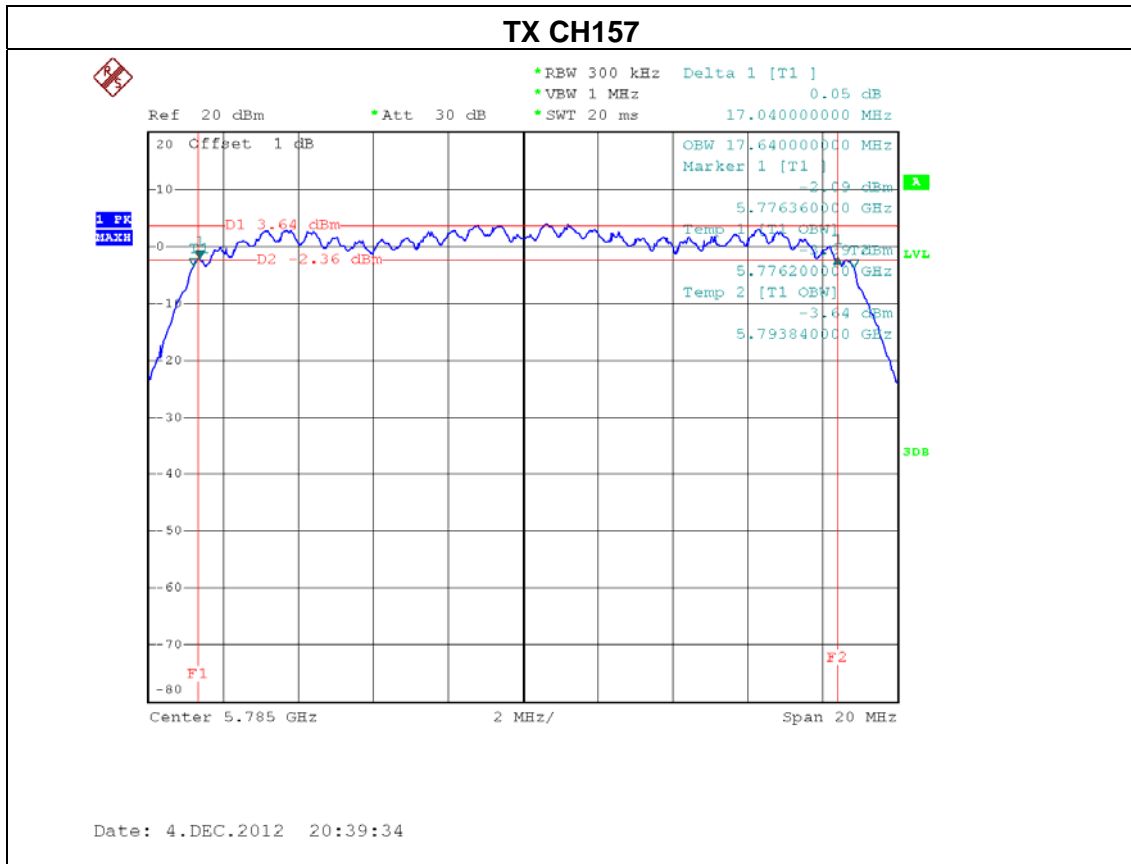



EUT :	Wireless Dual Band Router	Model Name. :	WF2471
Temperature :	25 °C	Relative Humidity :	58 %
Pressure :	1010 hPa	Test Voltage :	AC 120V/60Hz
Test Mode :	TX N40 Mode /CH151, CH159 -ANT 1		

Test Channel	Frequency (MHz)	6dB Bandwidth (MHz)	LIMIT (MHz)
CH151	5755	36.40	>=500KHz
CH159	5795	36.48	>=500KHz

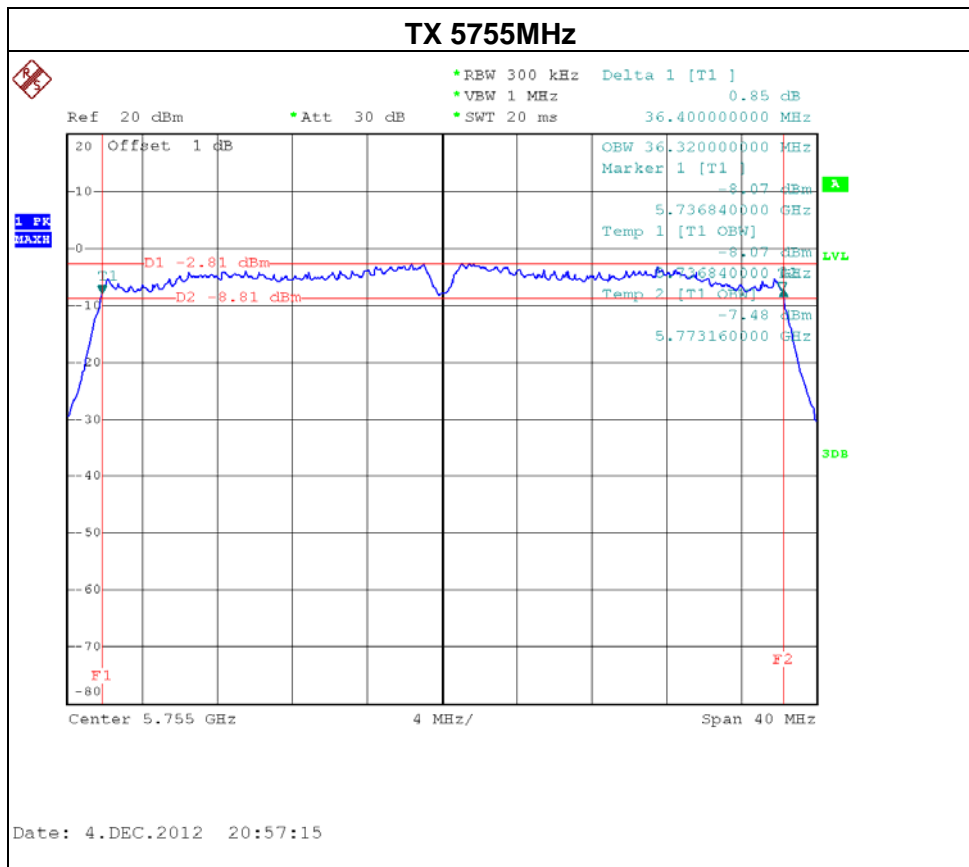

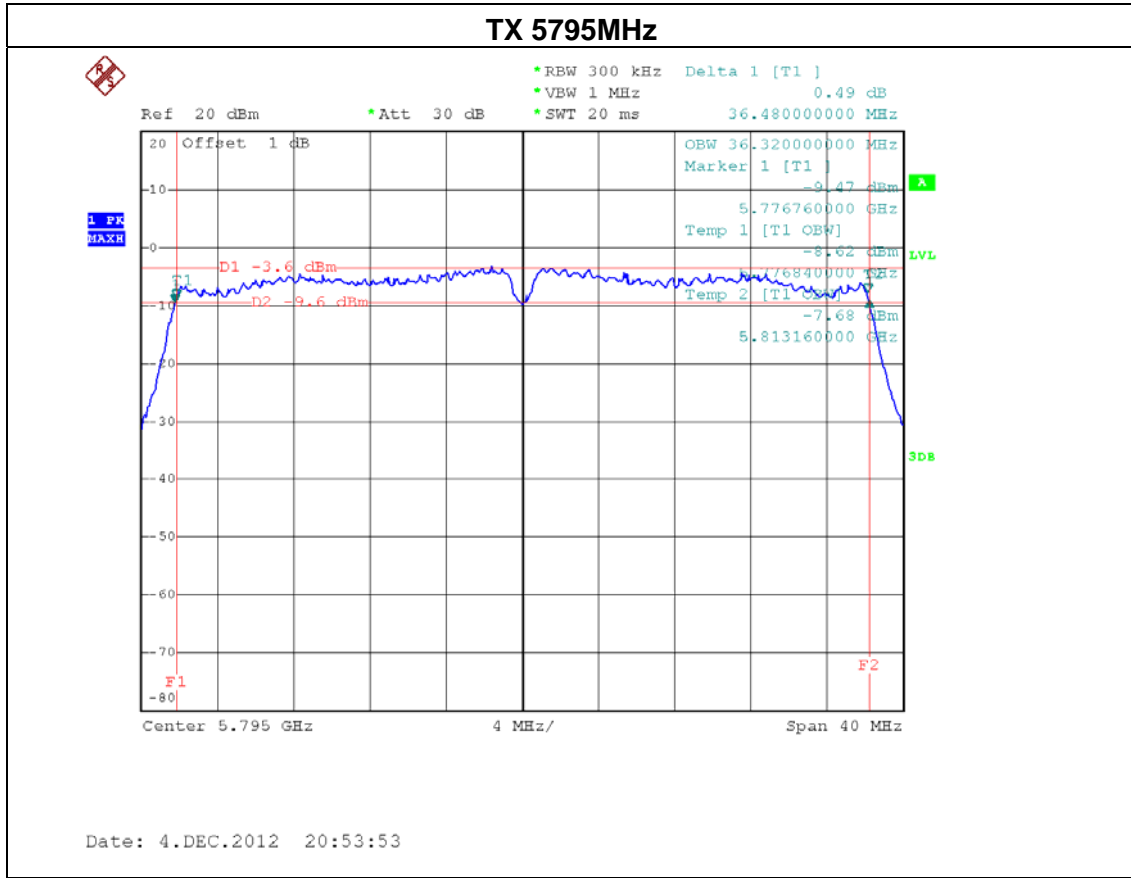



EUT :	Wireless Dual Band Router	Model Name. :	WF2471
Temperature :	25 °C	Relative Humidity :	58 %
Pressure :	1010 hPa	Test Voltage :	AC 120V/60Hz
Test Mode :	TX N40 Mode / CH151, CH159 -ANT 2		

Test Channel	Frequency (MHz)	6dB Bandwidth (MHz)	LIMIT (MHz)
CH151	5755	36.48	>=500KHz
CH159	5795	36.48	>=500KHz

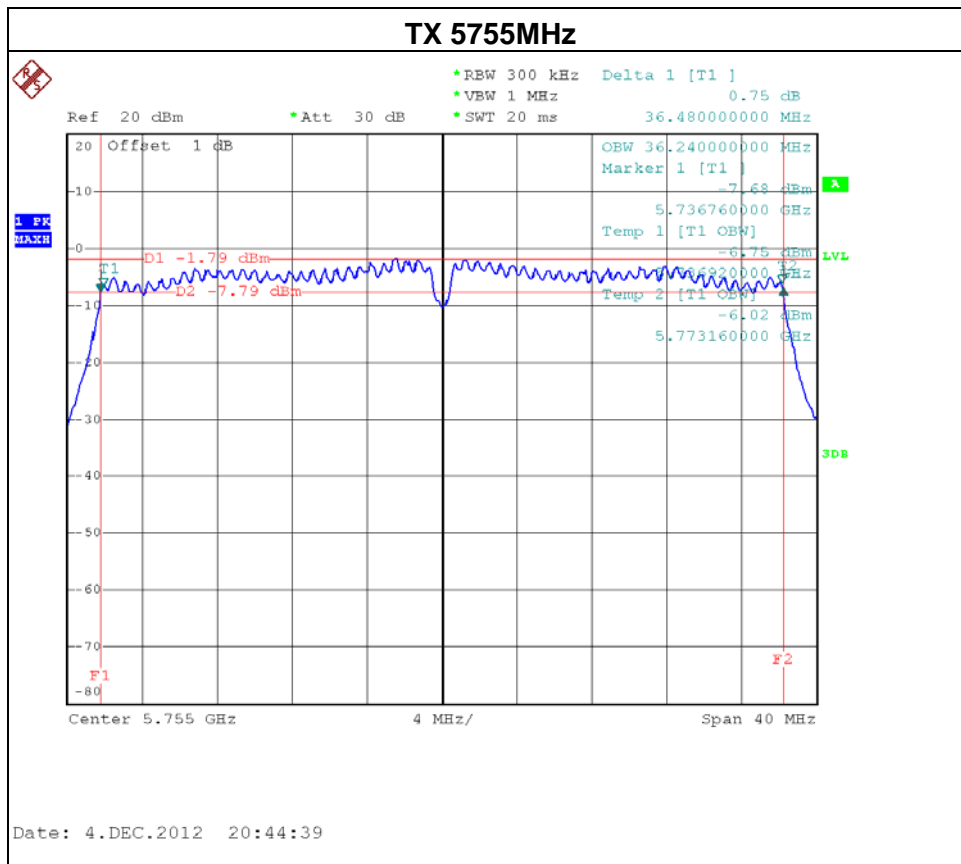

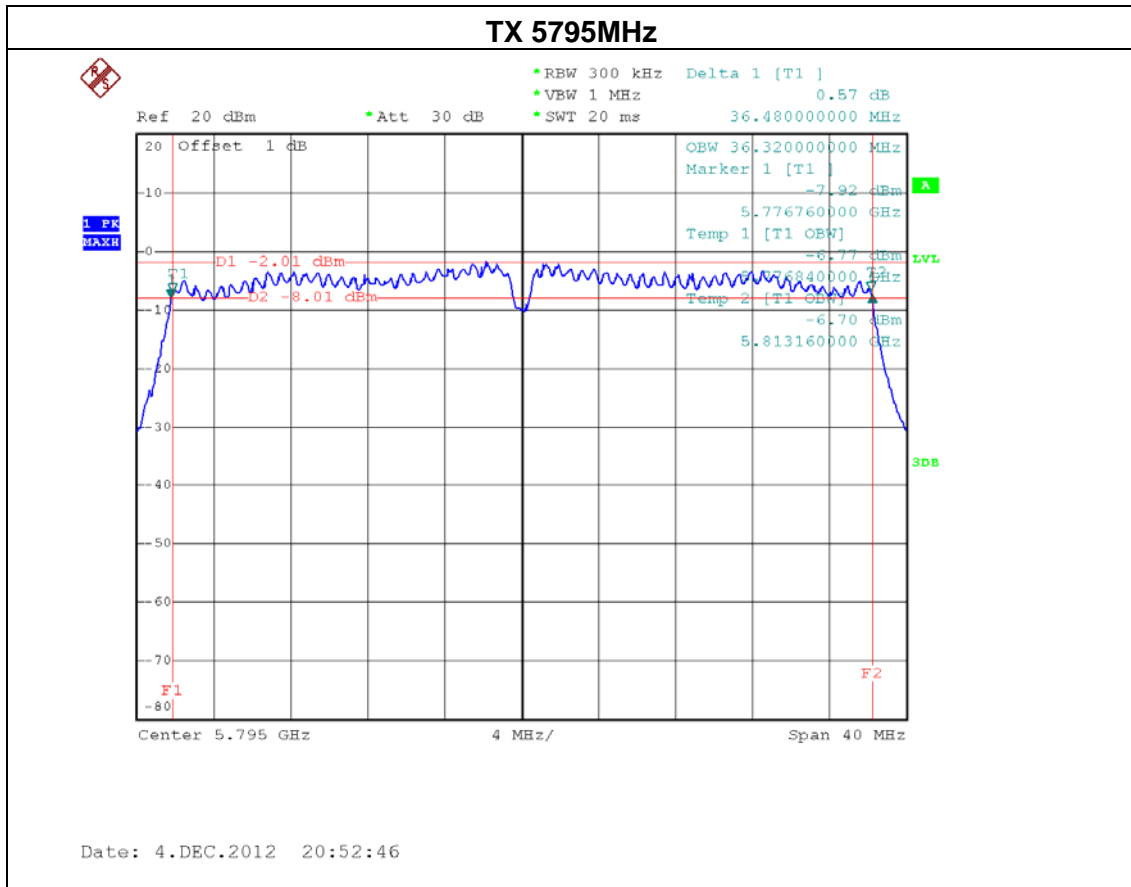



6. MAXIMUM OUTPUT POWER TEST

6.1 Applied procedures / limit

FCC Part15 (15.247) , Subpart C				
Section	Test Item	Limit	Frequency Range (MHz)	Result
15.247(b)(3)	Maximum Output Power	1 watt or 30dBm	5725 - 5825	PASS

6.1.1 MEASUREMENT INSTRUMENTS LIST

Item	Kind of Equipment	Manufacturer	Type No.	Serial No.	Last Calibration	Next Calibration
1	Spectrum Analyzer	R&S	FSP_40	100129	Nov.25.2012	Nov.16.2013

Remark: "N/A" denotes no model name, serial no. or calibration specified.
 All calibration period of Equipment List is One Year.

6.1.2 TEST PROCEDURE

- a. The EUT was directly connected to the spectrum analyzer and antenna output port as show in the block diagram below,

6.1.3 DEVIATION FROM STANDARD

No deviation.

6.1.4 TEST SETUP



6.1.5 EUT OPERATION CONDITIONS

The EUT tested system was configured as the statements of 4.1.6 Unless otherwise a special operating condition is specified in the follows during the testing.



6.1.6 TEST RESULTS

EUT :	Wireless Dual Band Router	Model Name :	WF2471
Temperature :	25 °C	Relative Humidity :	58 %
Pressure :	1010 hPa	Test Voltage :	AC 120V/60Hz
Test Mode :	TX A Mode /CH149, CH157, CH165		

Test Channel	Frequency (MHz)	Maximum Output Power (dBm)	LIMIT (dBm)	LIMIT (W)
CH149	5745 MHz	21.62	30	1
CH157	5785 MHz	21.57	30	1
CH165	5825 MHz	21.49	30	1



EUT :	Wireless Dual Band Router	Model Name :	WF2471
Temperature :	25 °C	Relative Humidity :	58 %
Pressure :	1010 hPa	Test Voltage :	AC 120V/60Hz
Test Mode :	TX N20 Mode /CH149, CH157, CH165		

ANT 1				
Test Channel	Frequency (MHz)	Maximum Output Power (dBm)	LIMIT (dBm)	LIMIT (W)
CH149	5745 MHz	16.48	30	1
CH157	5785 MHz	16.78	30	1
CH165	5825 MHz	16.85	30	1

ANT 2				
Test Channel	Frequency (MHz)	Maximum Output Power (dBm)	LIMIT (dBm)	LIMIT (W)
CH149	5745 MHz	16.29	30	1
CH157	5785 MHz	16.57	30	1
CH165	5825 MHz	16.96	30	1

ANT 1+ANT 2				
Test Channel	Frequency (MHz)	Maximum Output Power (dBm)	LIMIT (dBm)	LIMIT (W)
CH149	5745 MHz	19.40	28.42	0.695
CH157	5785 MHz	19.69	28.42	0.695
CH165	5825MHz	19.92	28.42	0.695

Remark :

- (1) **The MIMO test requirement, RF conducted output power shall measure each transmitter chain by using channel power method.**
And after obtain each individual transmitter chain power, then sum the output power by using the following formula:

$$((\text{dBm}/\text{Chain 1})/10^{\wedge}\text{Log}) + ((\text{dBm}/\text{Chain 2})/10^{\wedge}\text{log}) + ((\text{dBm}/\text{ChainN})/10^{\wedge}\text{log}) =$$
Combined peak output power in mW.
- (2) **Antenna Gain=4.58 dBi.**
- (3) This EUT supports MIMO 2T2R, all transmit signals are completely uncorrelated, then,
Directional gain = $G_{ANT} + 10 \log(N)$ dBi , that is Directional gain=7.58; So,the out power limit is $30-7.58+6=28.42$; and power density limit is $8-7.58+6=6.42$



EUT :	Wireless Dual Band Router	Model Name :	WF2471
Temperature :	25 °C	Relative Humidity :	58 %
Pressure :	1010 hPa	Test Voltage :	AC 120V/60Hz
Test Mode :	TX N40 Mode /CH151, CH159		

ANT 1				
Test Channel	Frequency (MHz)	Maximum Output Power (dBm)	LIMIT (dBm)	LIMIT (W)
CH151	5755 MHz	14.43	30	1
CH159	5795 MHz	14.56	30	1

ANT 2				
Test Channel	Frequency (MHz)	Maximum Output Power (dBm)	LIMIT (dBm)	LIMIT (W)
CH151	5755 MHz	14.35	30	1
CH159	5795 MHz	14.84	30	1

ANT1+ANT2				
Test Channel	Frequency (MHz)	Maximum Output Power (dBm)	LIMIT (dBm)	LIMIT (W)
CH151	5755 MHz	17.40	28.42	0.695
CH159	5795 MHz	17.71	28.42	0.695

Remark :

- (1) **The MIMO test requirement, RF conducted output power shall measure each transmitter chain by using channel power method.**
And after obtain each individual transmitter chain power, then sum the output power by using the following formula:

$$((\text{dBm}/\text{Chain 1})/10^{\wedge}\text{Log}) + ((\text{dBm}/\text{Chain 2})/10^{\wedge}\text{log}) + ((\text{dBm}/\text{ChainN})/10^{\wedge}\text{log}) =$$
Combined peak output power in mW.
- (2) **Antenna Gain=4.58 dBi.**
- (3) This EUT supports MIMO 2T2R, all transmit signals are completely uncorrelated, then, **Directional gain = $G_{ANT} + 10 \log(N)$ dBi**, that is Directional gain=7.58; So,the out power limit is 30-7.58+6=28.42; and power density limit is 8-7.58+6=6.42



7. ANTENNA CONDUCTED SPURIOUS EMISSION

7.1 Applied procedures / limit

20dBc in any 100 kHz bandwidth outside the operating frequency band. In case the emission fall within the restricted band specified on 15.205(a), then the 15.209(a) limit in the table below has to be followed.

Frequencies (MHz)	Field Strength (micorvolts/meter)	Measurement Distance (meters)
0.009~0.490	2400/F(KHz)	300
0.490~1.705	24000/F(KHz)	30
1.705~30.0	30	30
30~88	100	3
88~216	150	3
216~960	200	3
Above 960	500	3

7.1.1 MEASUREMENT INSTRUMENTS LIST

Item	Kind of Equipment	Manufacturer	Type No.	Serial No.	Last Calibration	Next Calibration
1	Spectrum Analyzer	R&S	FSP_40	100185	Nov.25.2012	Nov.16.2013

Remark: "N/A" denotes no model name, serial no. or calibration specified.
All calibration period of Equipment List is One Year.

7.1.2 TEST PROCEDURE

- a. The EUT was directly connected to the spectrum analyzer and antenna output port as show in the block diagram below,
- b. Spectrum Setting : RBW= 100KHz, VBW=300KHz, Sweep time =20 ms.

7.1.3 DEVIATION FROM STANDARD

No deviation.

7.1.4 TEST SETUP



7.1.5 EUT OPERATION CONDITIONS

The EUT tested system was configured as the statements of 4.1.6 Unless otherwise a special operating condition is specified in the follows during the testing.



7.1.6 TEST RESULTS

EUT :	Wireless Dual Band Router	Model Name :	WF2471
Temperature :	25 °C	Relative Humidity :	58 %
Pressure :	1010 hPa	Test Voltage :	AC 120V/60Hz
Test Mode :	TX A Mode /CH149, CH157, CH165		

Channel of Worst Data: CH149			
The max. radio frequency power in any 100kHz bandwidth outside the frequency band		The max. radio frequency power in any 100 kHz bandwidth within the frequency band.	
FREQUENCY(MHz)	POWER(dBm)	FREQUENCY(MHz)	POWER(dBm)
5725.00	-31.95	5853.00	-40.27
Result			
In any 100kHz bandwidth outside the frequency band, the radio frequency power is at least 20dB below that in the 100kHz bandwidth within the band that contains the highest level of the desired power.			

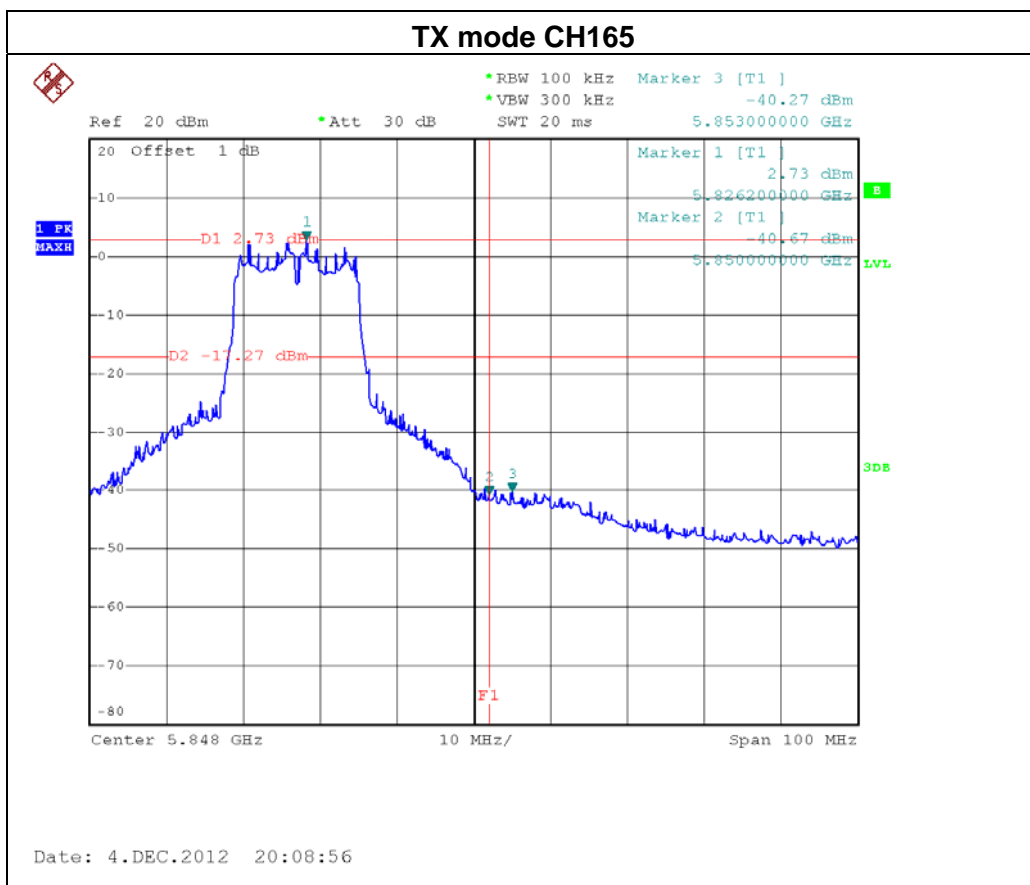
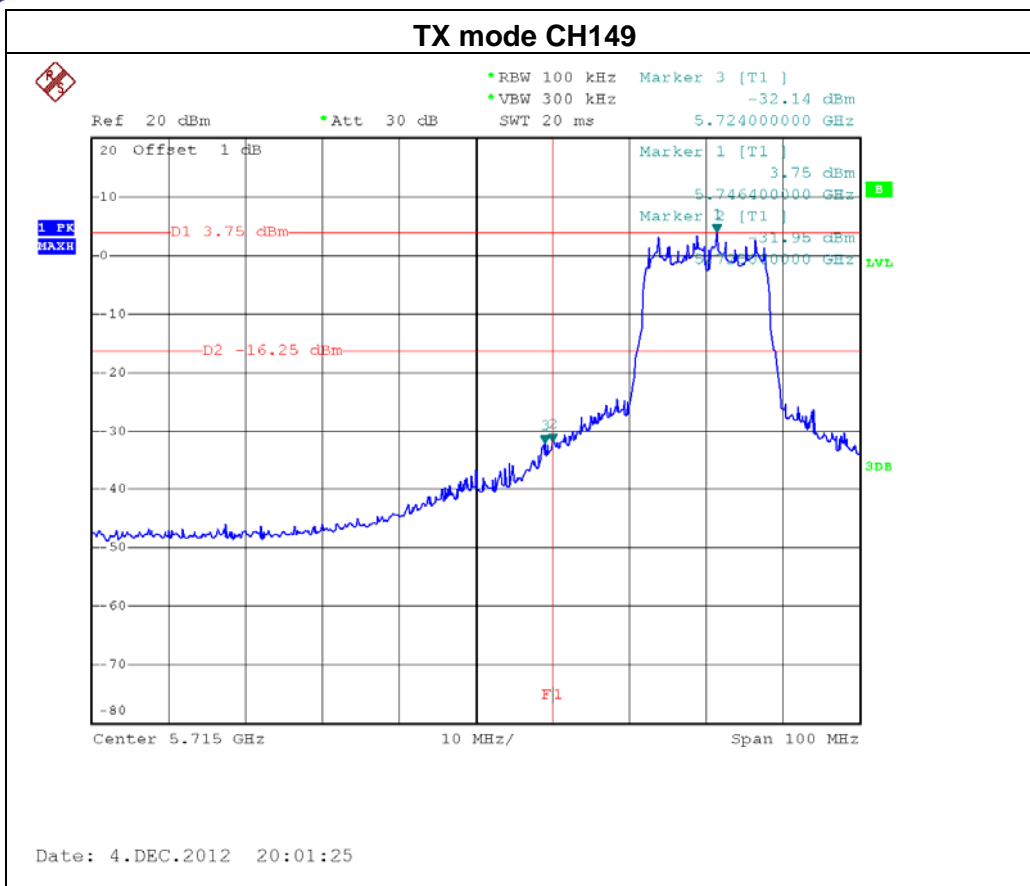

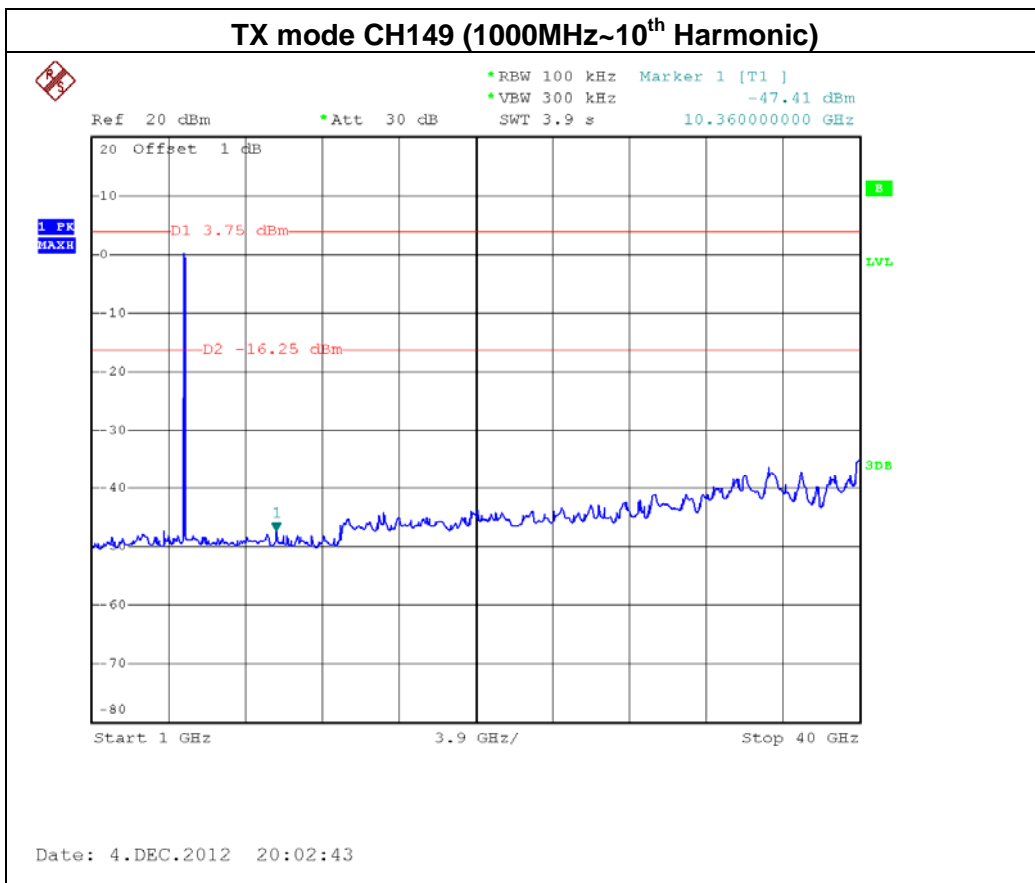
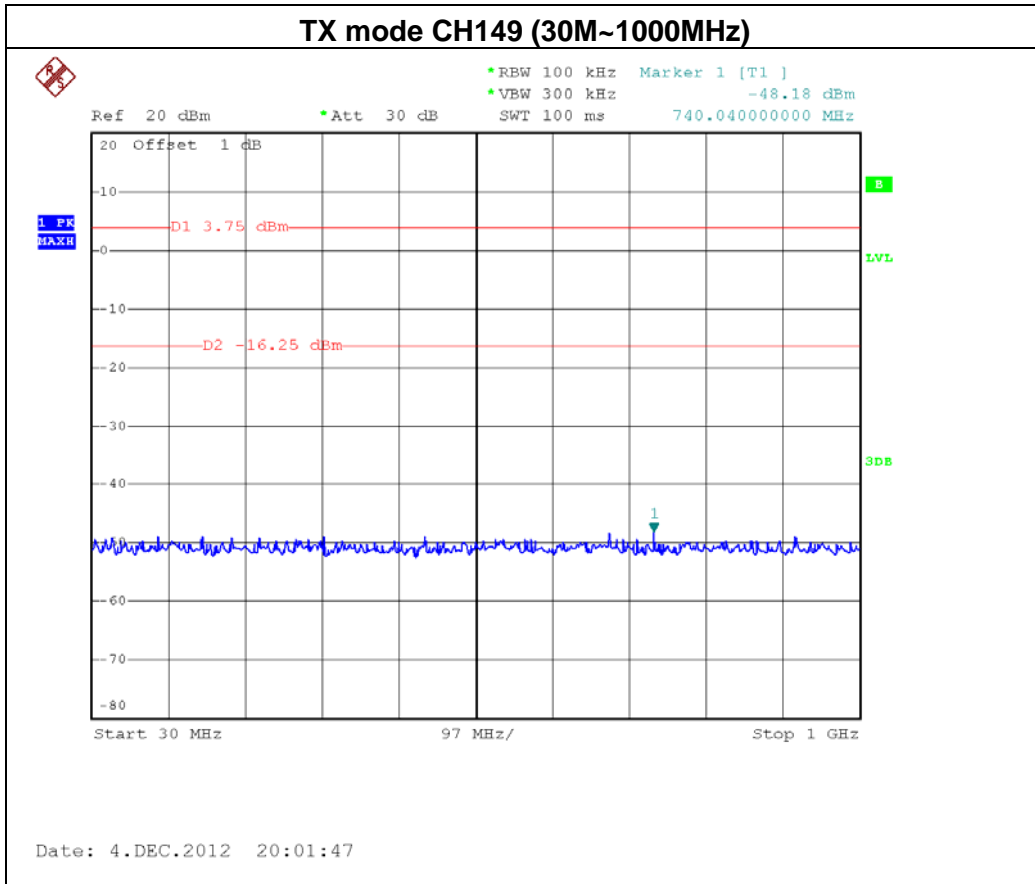

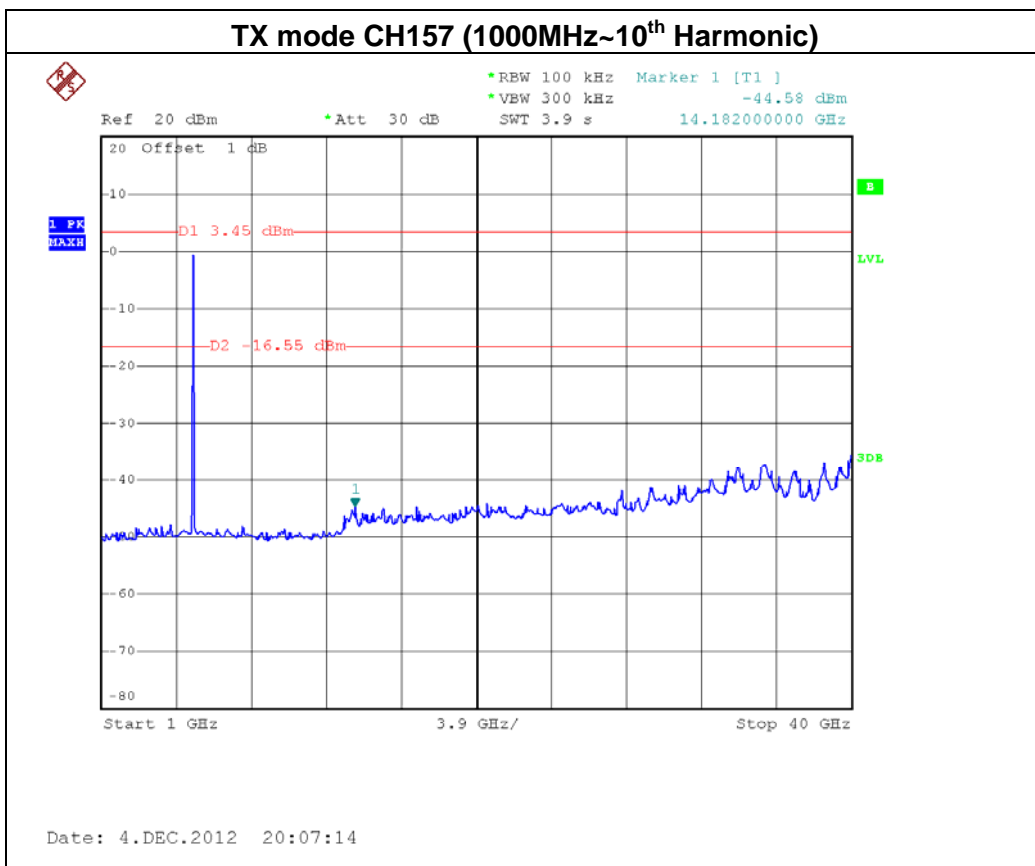
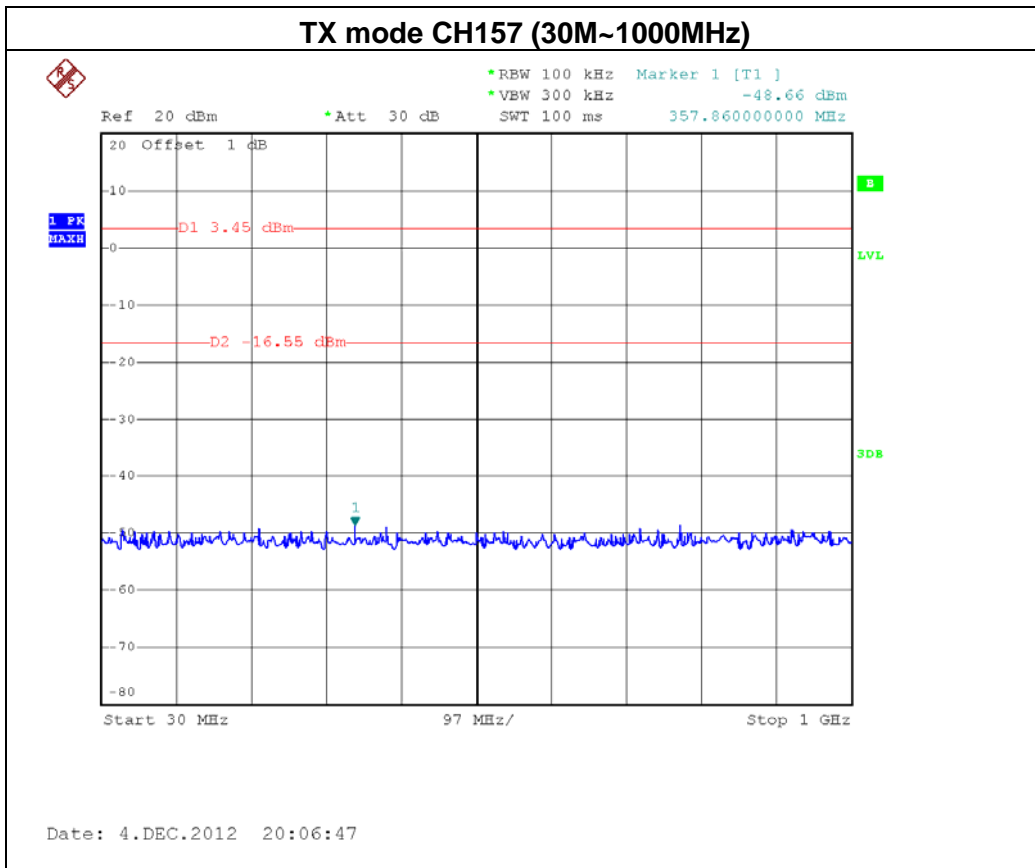

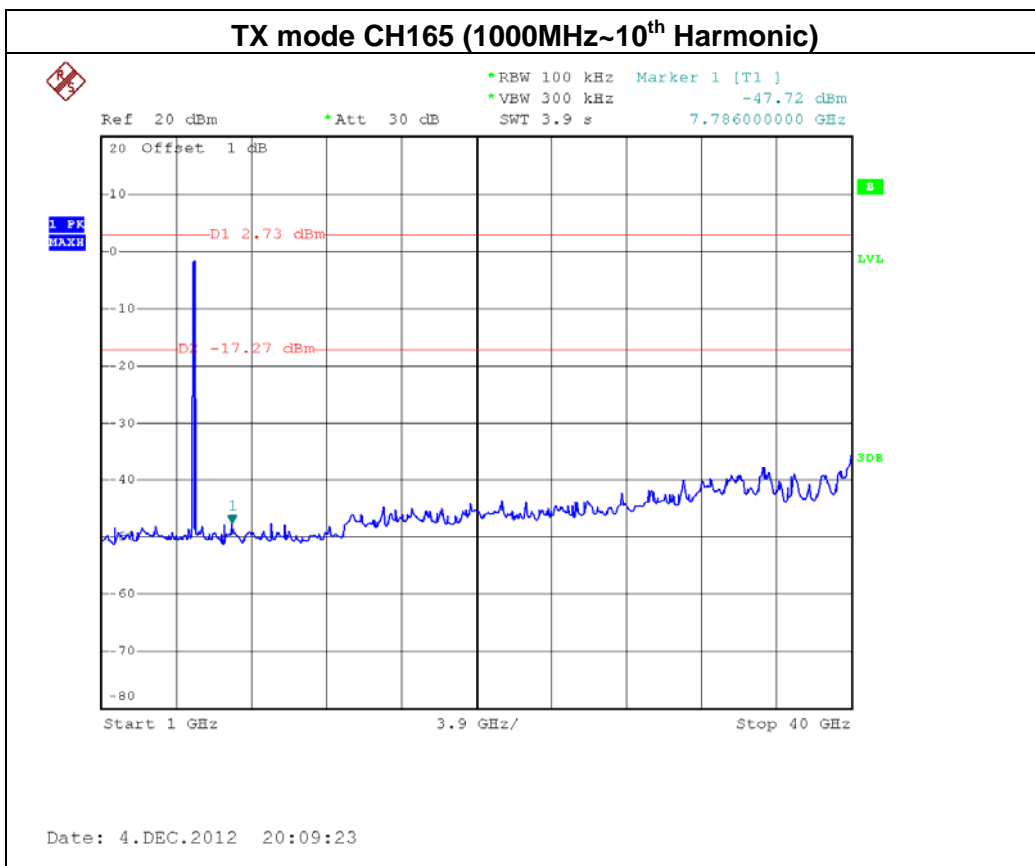
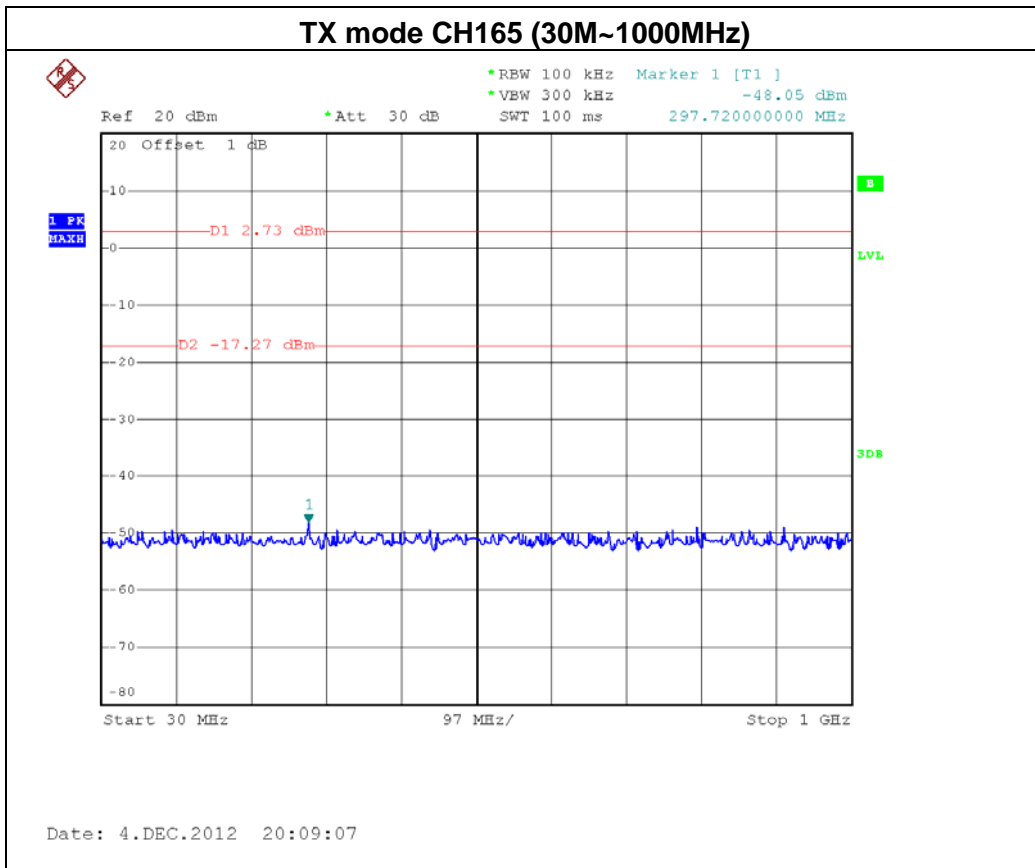



EUT :	Wireless Dual Band Router	Model Name :	WF2471
Temperature :	25 °C	Relative Humidity :	58 %
Pressure :	1010 hPa	Test Voltage :	AC 120V/60Hz
Test Mode :	TX N20 Mode /CH149, CH157, CH165 -ANT 1		

Channel of Worst Data: CH149

The max. radio frequency power in any 100kHz bandwidth outside the frequency band	The max. radio frequency power in any 100 kHz bandwidth within the frequency band.
---	--

FREQUENCY(MHz)	POWER(dBm)	FREQUENCY(MHz)	POWER(dBm)
5725.00	-43.31	5858.60	-44.27

Result

In any 100kHz bandwidth outside the frequency band, the radio frequency power is at least 20dB below that in the 100kHz bandwidth within the band that contains the highest level of the desired power.

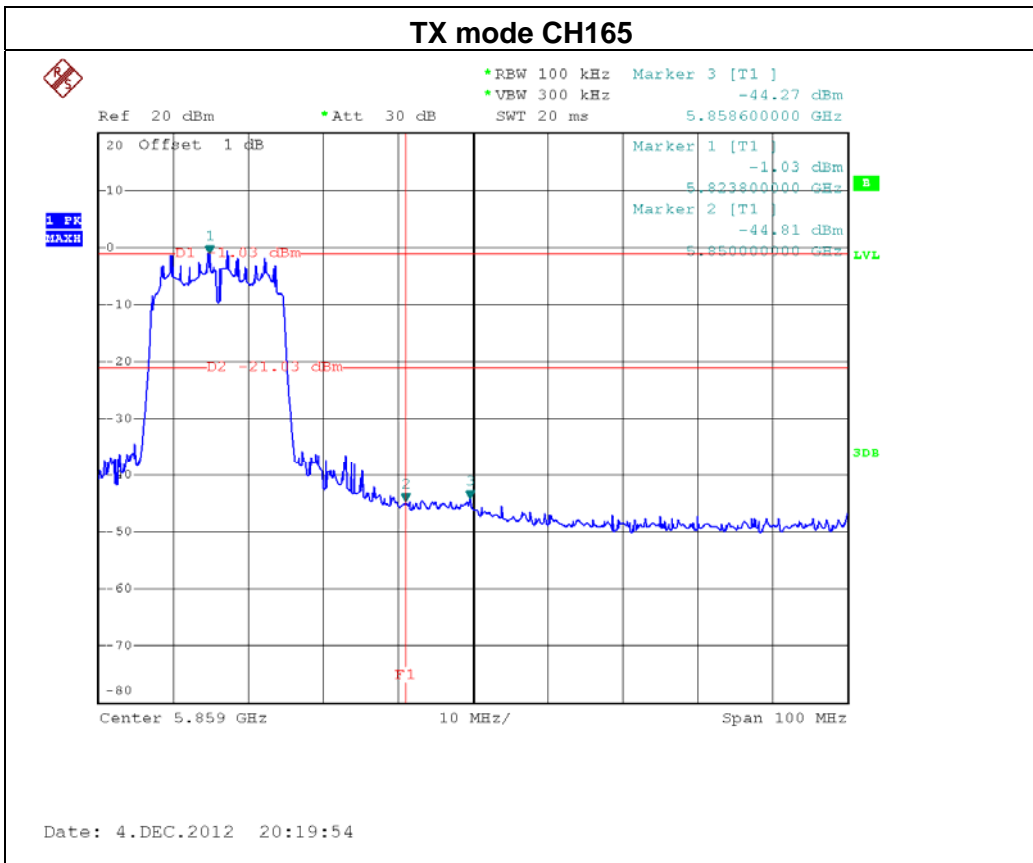
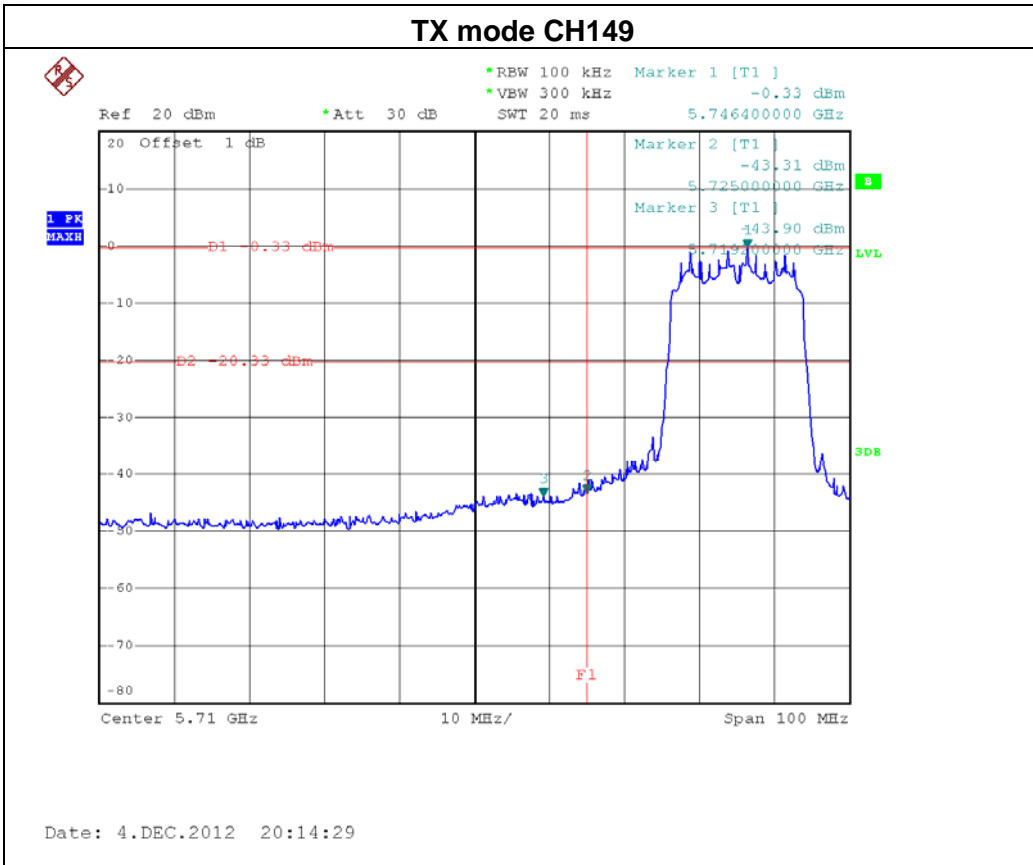

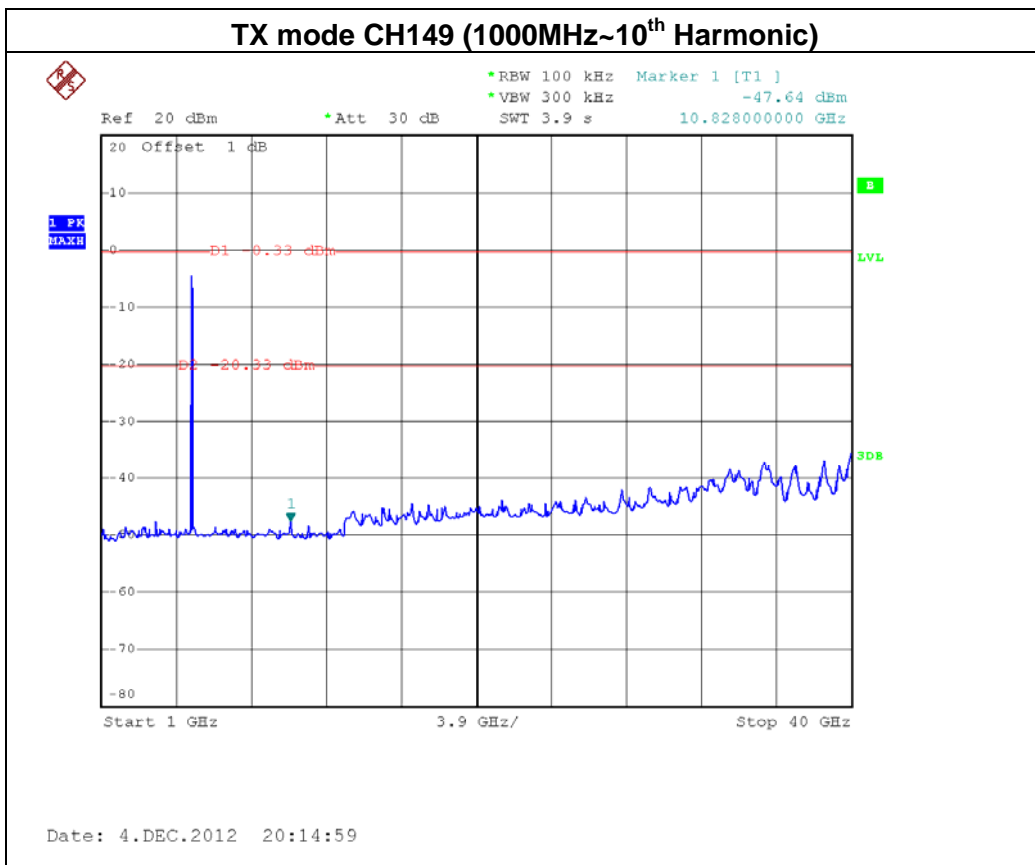
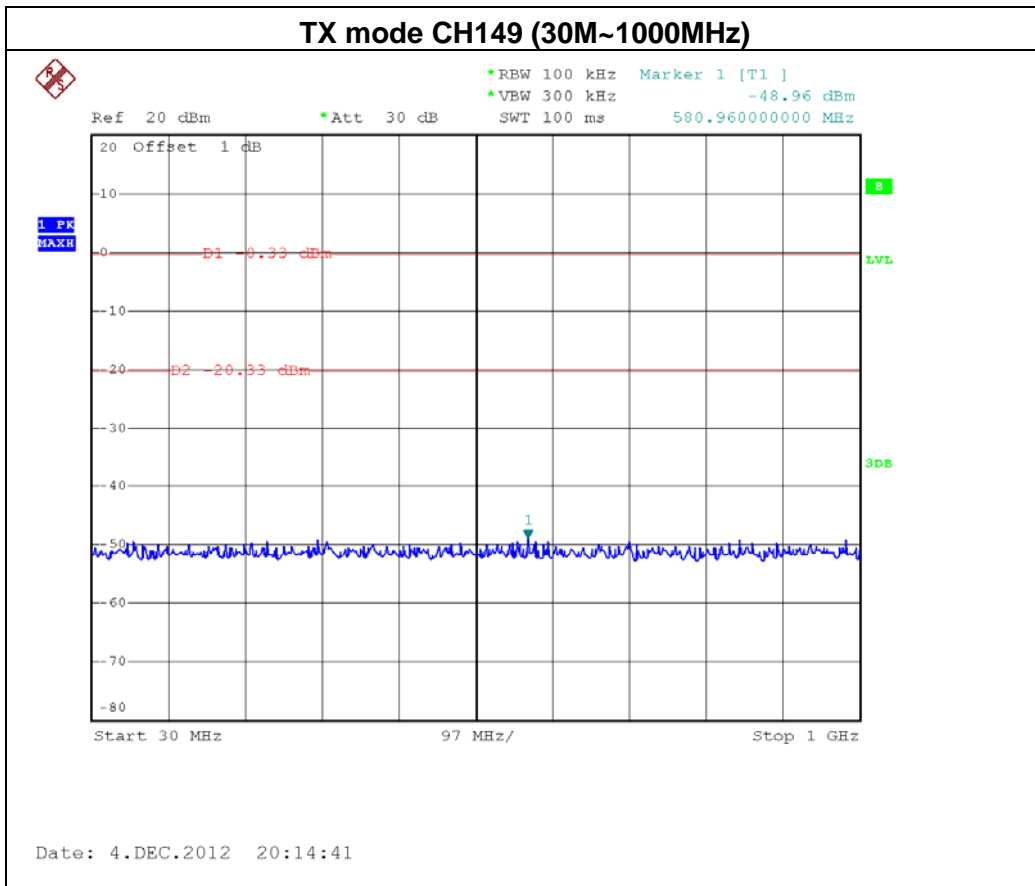

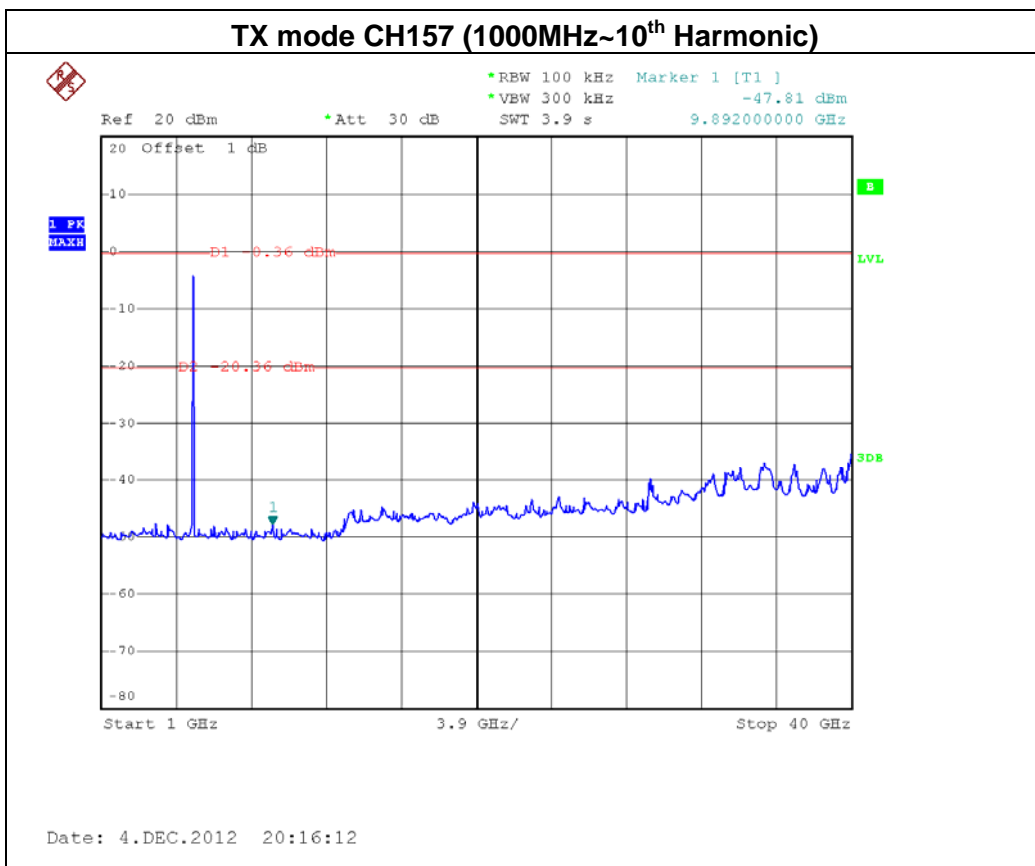
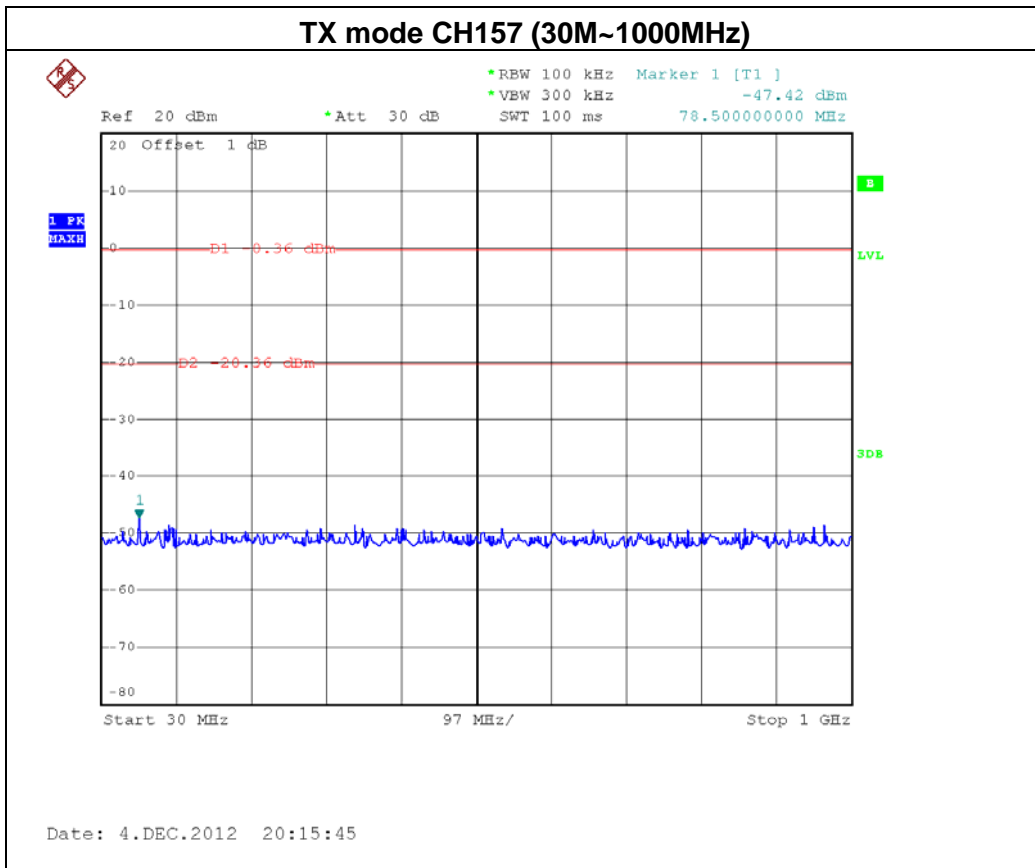

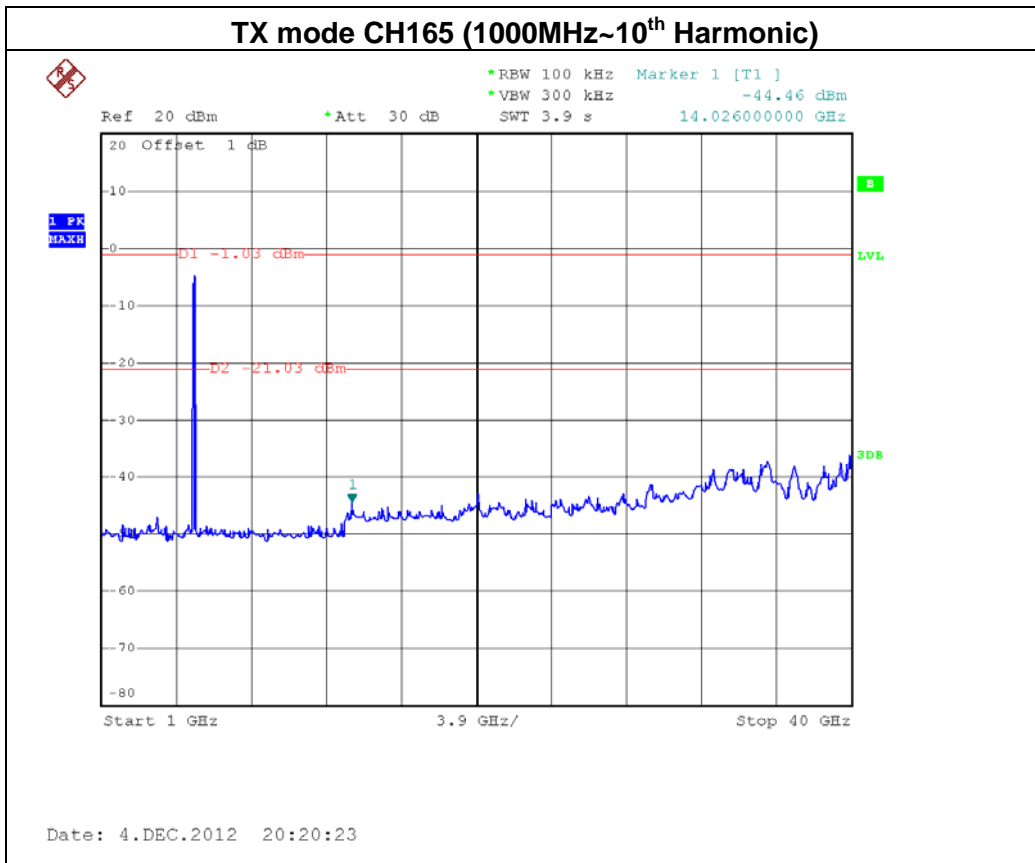
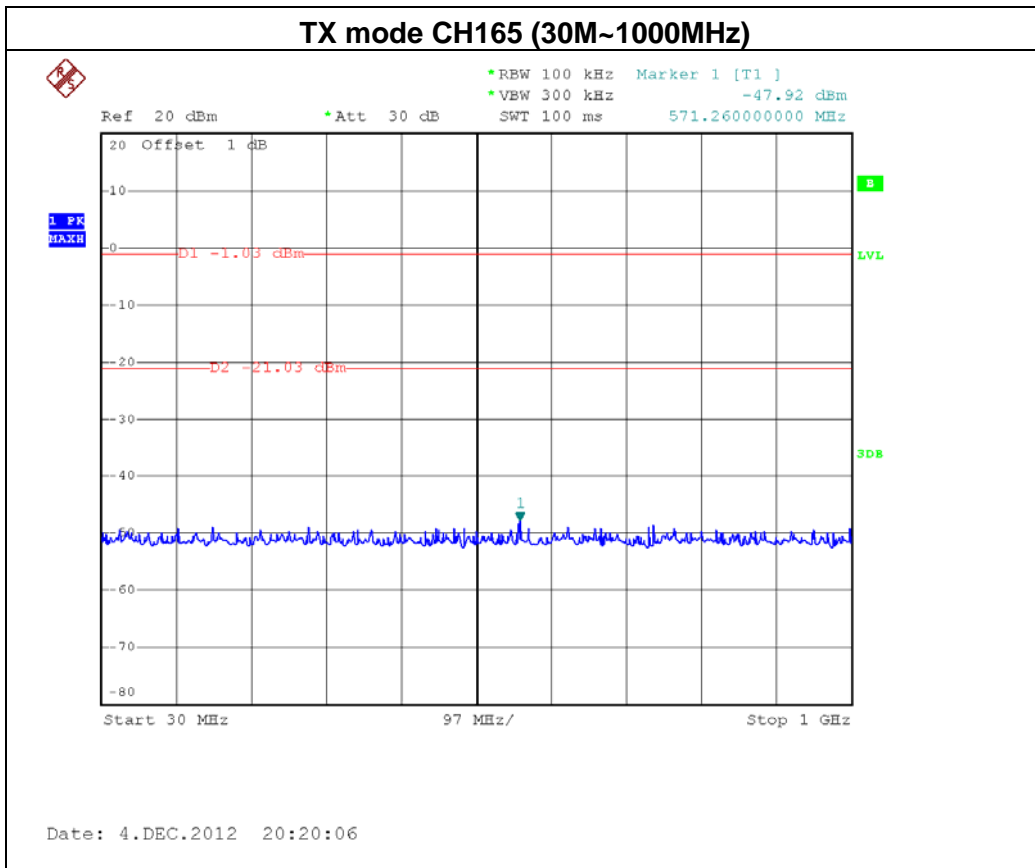



EUT :	Wireless Dual Band Router	Model Name :	WF2471
Temperature :	25 °C	Relative Humidity :	58 %
Pressure :	1010 hPa	Test Voltage :	AC 120V/60Hz
Test Mode :	TX N20 Mode /CH149, CH157, CH165 -ANT 2		

Channel of Worst Data: CH149

The max. radio frequency power in any 100kHz bandwidth outside the frequency band		The max. radio frequency power in any 100 kHz bandwidth within the frequency band.	
FREQUENCY(MHz)	POWER(dBm)	FREQUENCY(MHz)	POWER(dBm)
5722.20	-42.72	5850.00	-43.96

Result

In any 100kHz bandwidth outside the frequency band, the radio frequency power is at least 20dB below that in the 100kHz bandwidth within the band that contains the highest level of the desired power.

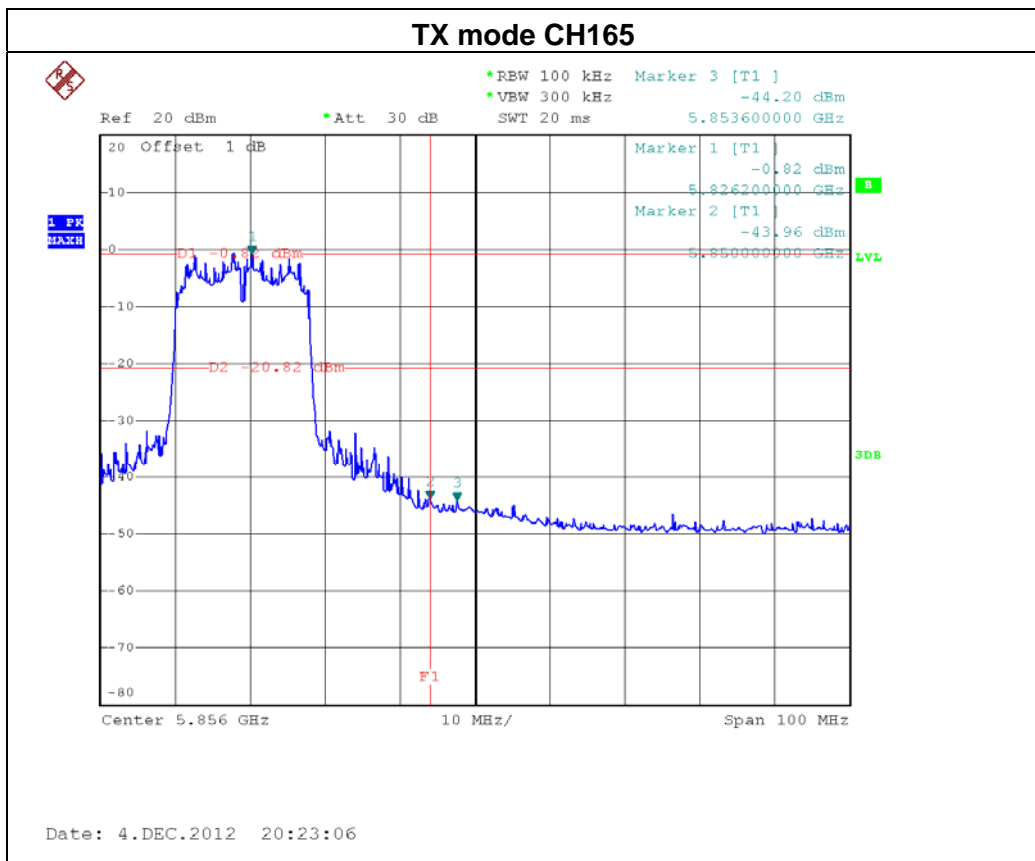
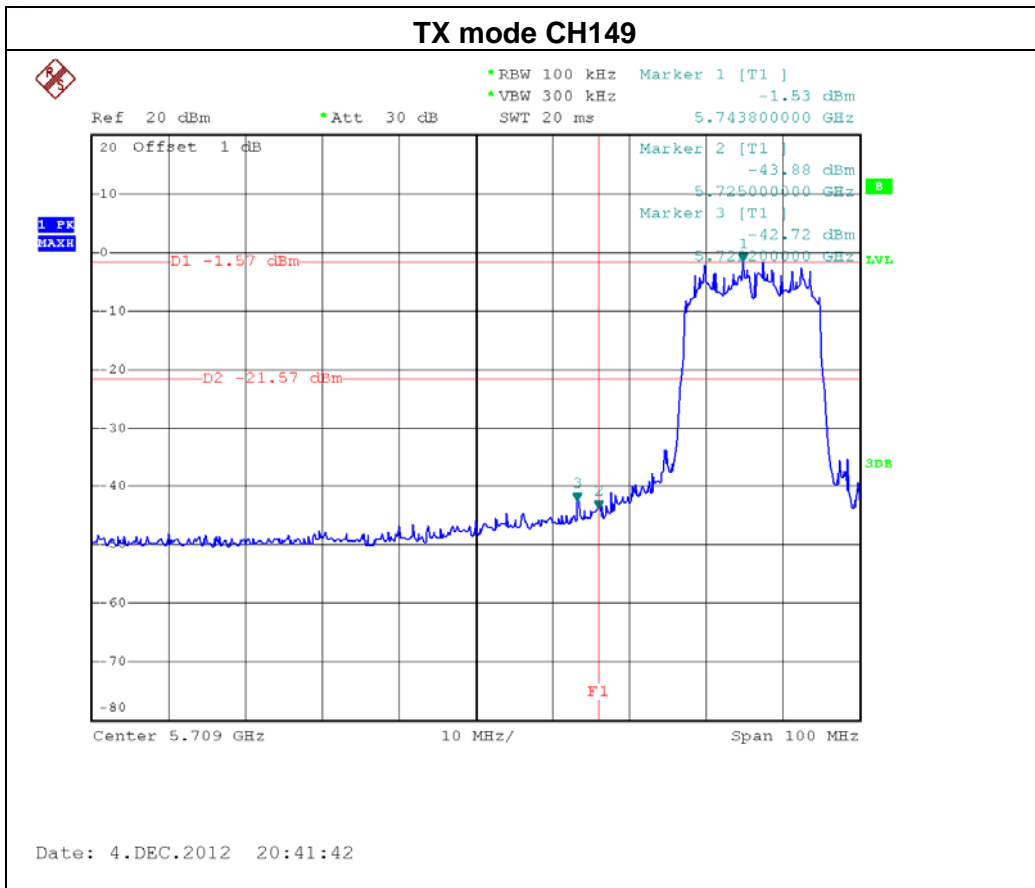

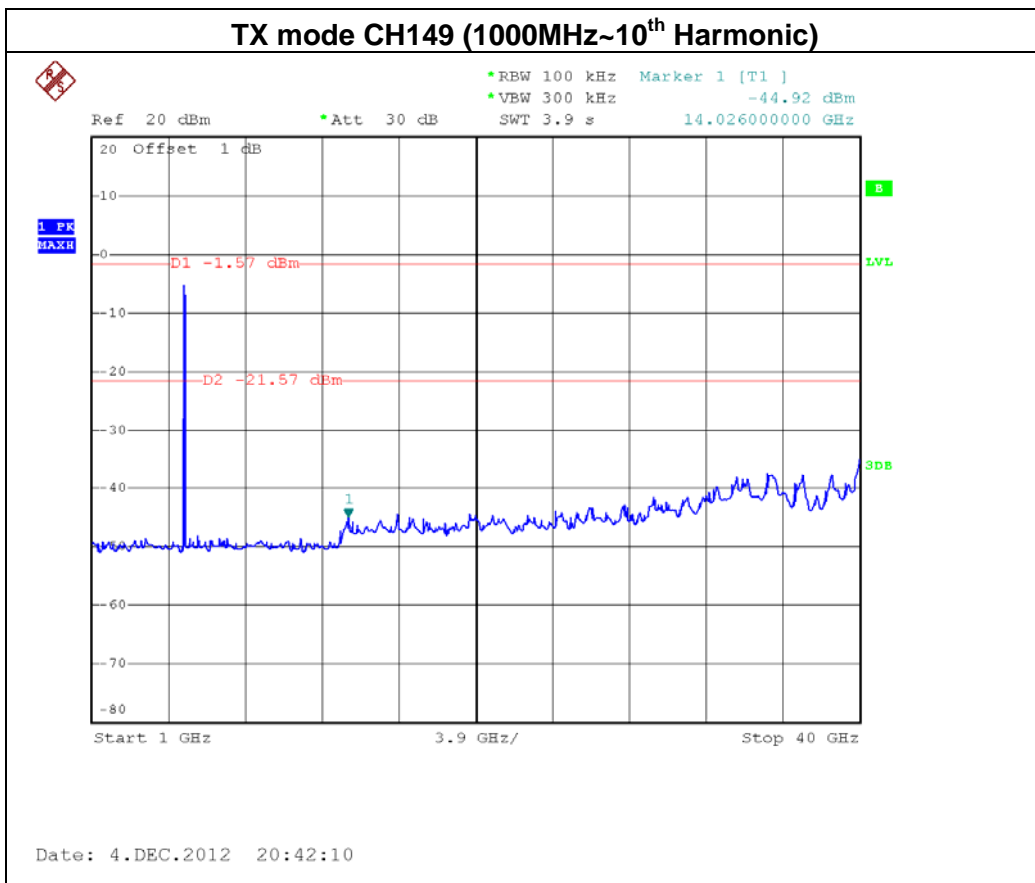
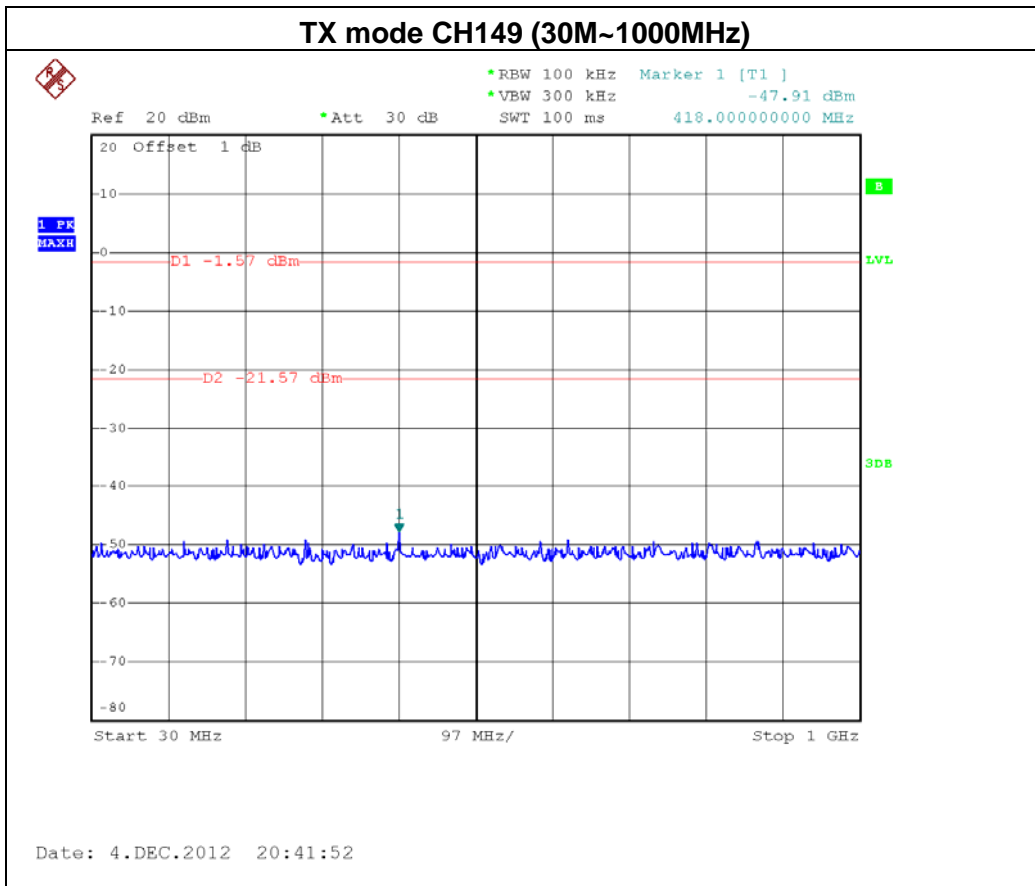

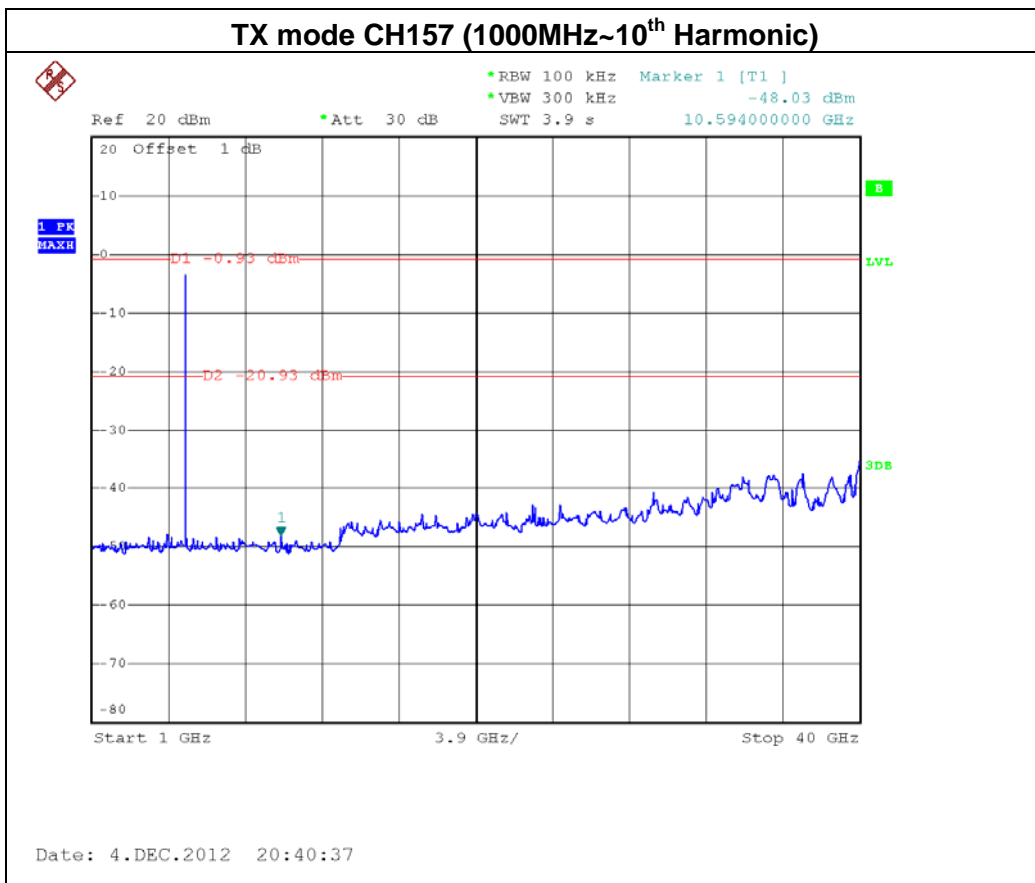
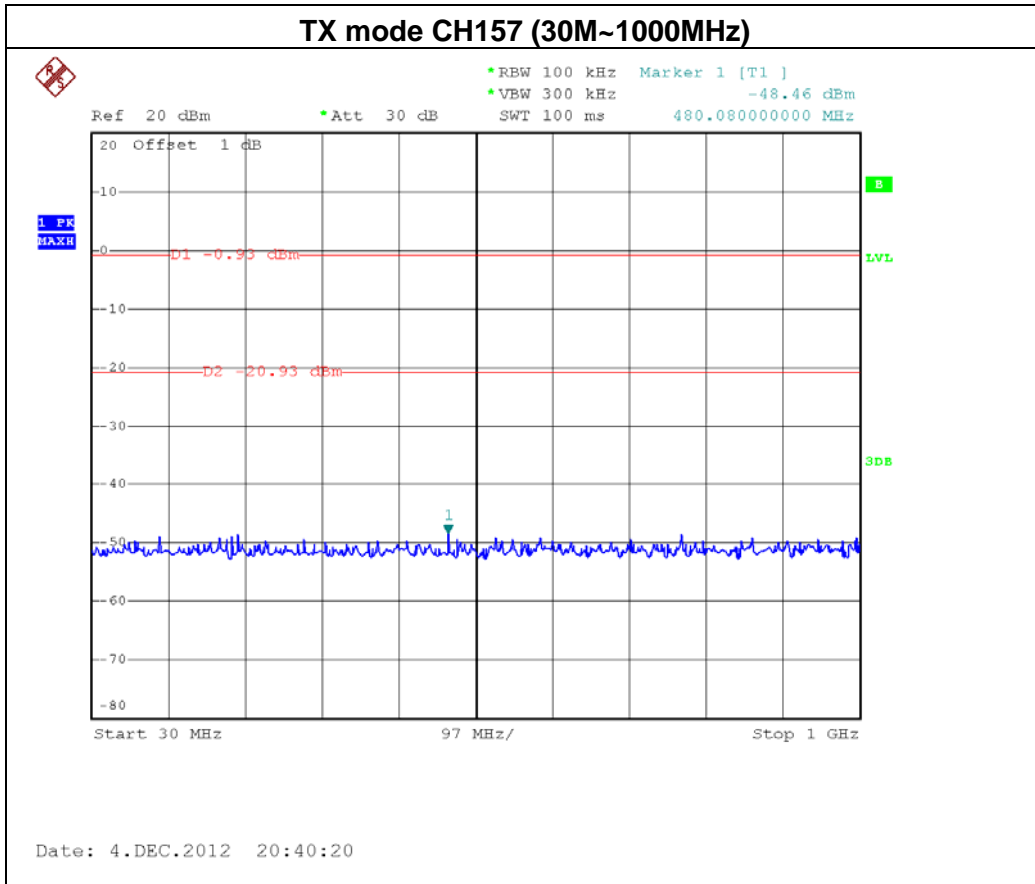

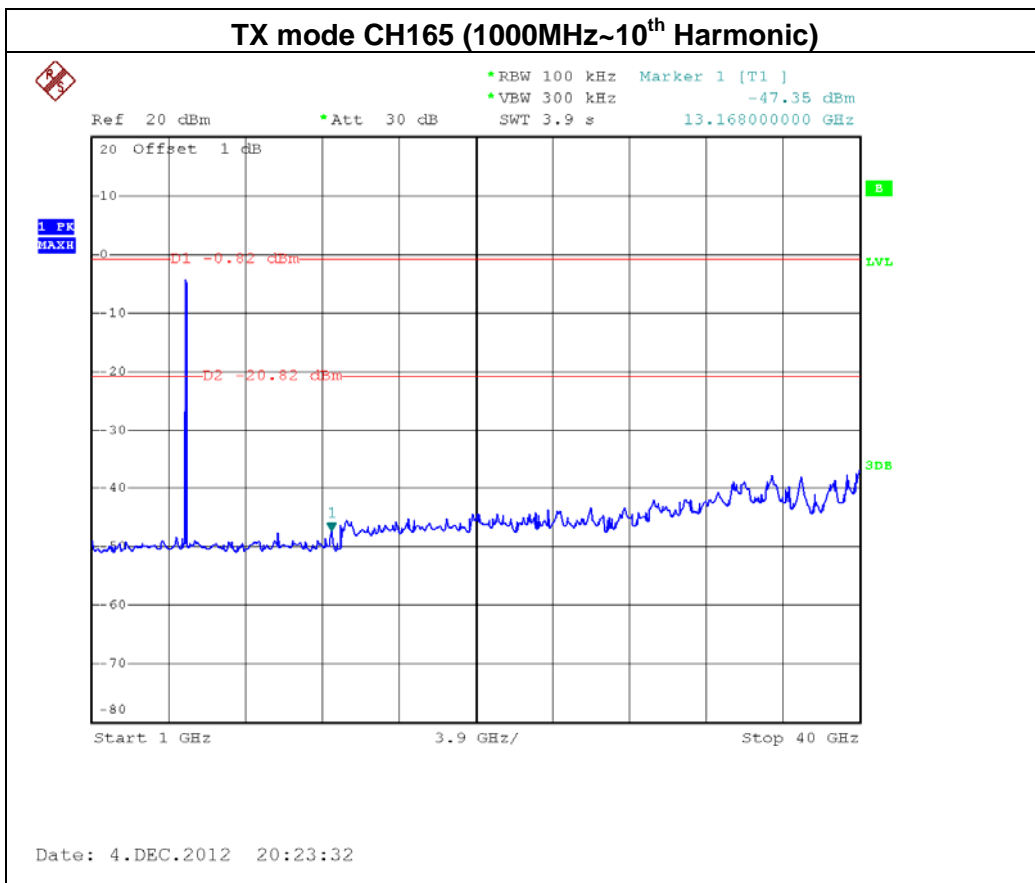
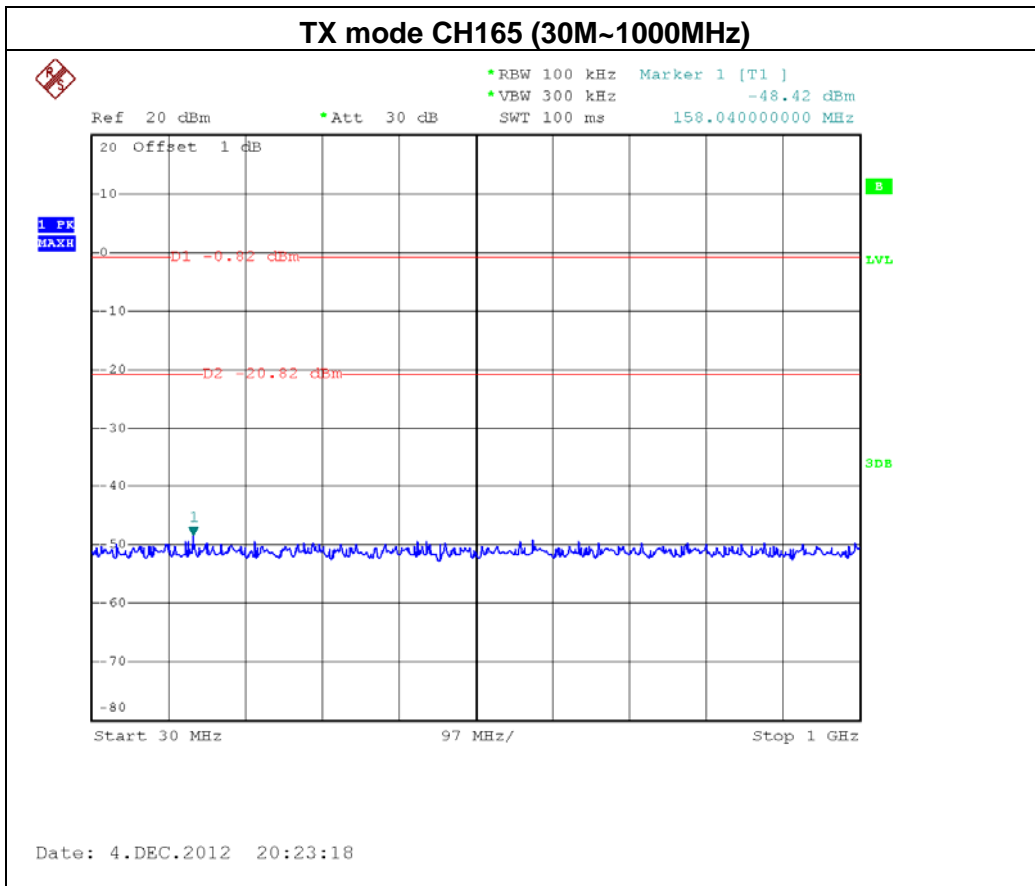



EUT :	Wireless Dual Band Router	Model Name :	WF2471
Temperature :	25 °C	Relative Humidity :	58 %
Pressure :	1010 hPa	Test Voltage :	AC 120V/60Hz
Test Mode :	TX N40 Mode /CH151, CH159 -ANT 1		

Channel of Worst Data: CH151

The max. radio frequency power in any 100kHz bandwidth outside the frequency band	The max. radio frequency power in any 100 kHz bandwidth within the frequency band.
---	--

FREQUENCY(MHz)	POWER(dBm)	FREQUENCY(MHz)	POWER(dBm)
5721.40	-40.46	5855.20	-48.19

Result

In any 100kHz bandwidth outside the frequency band, the radio frequency power is at least 20dB below that in the 100kHz bandwidth within the band that contains the highest level of the desired power.

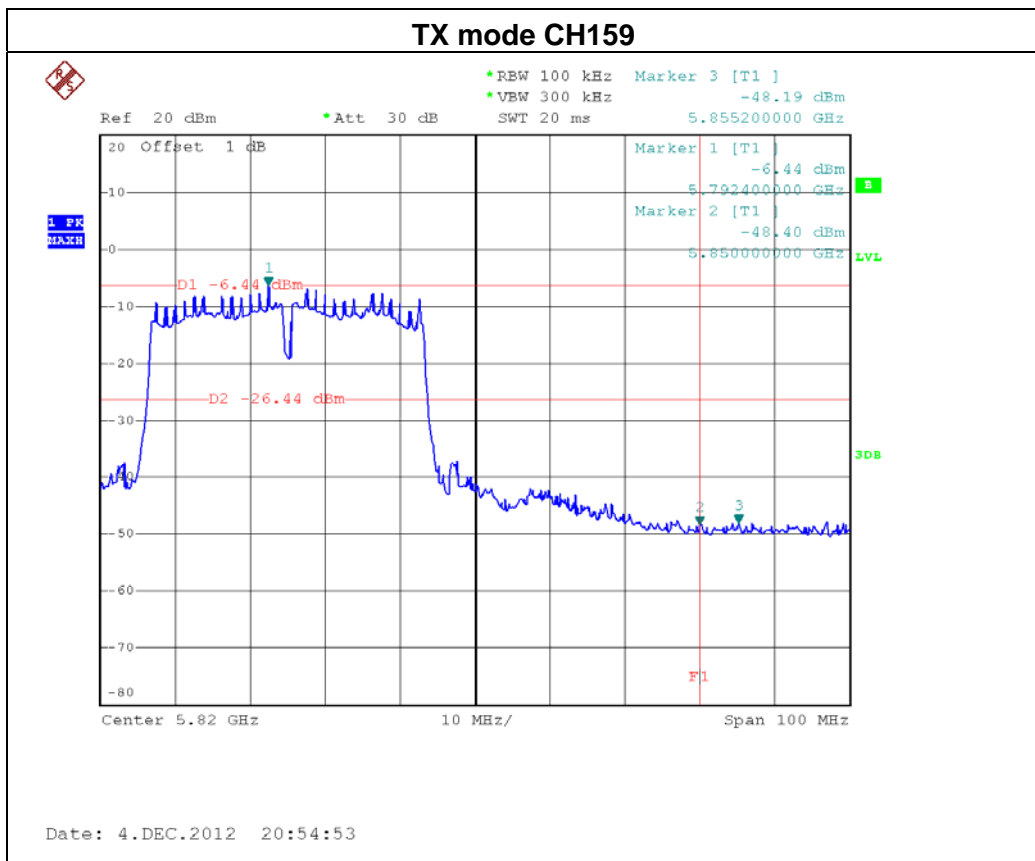
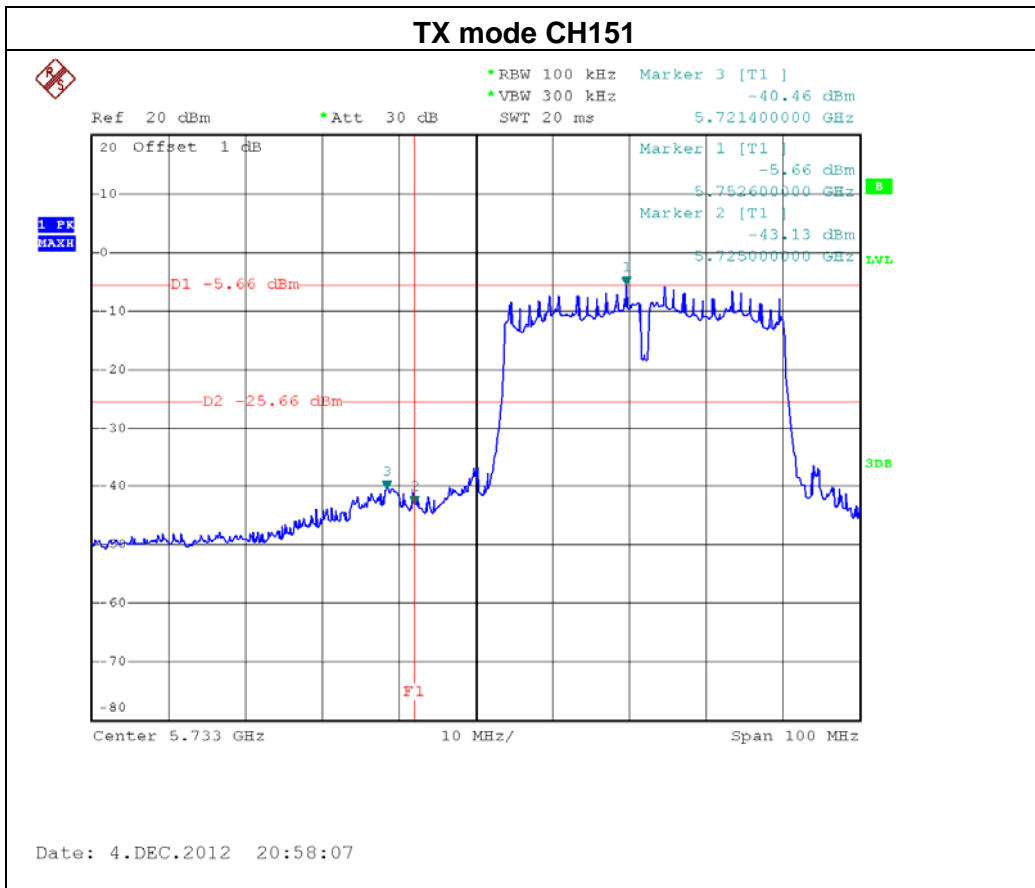

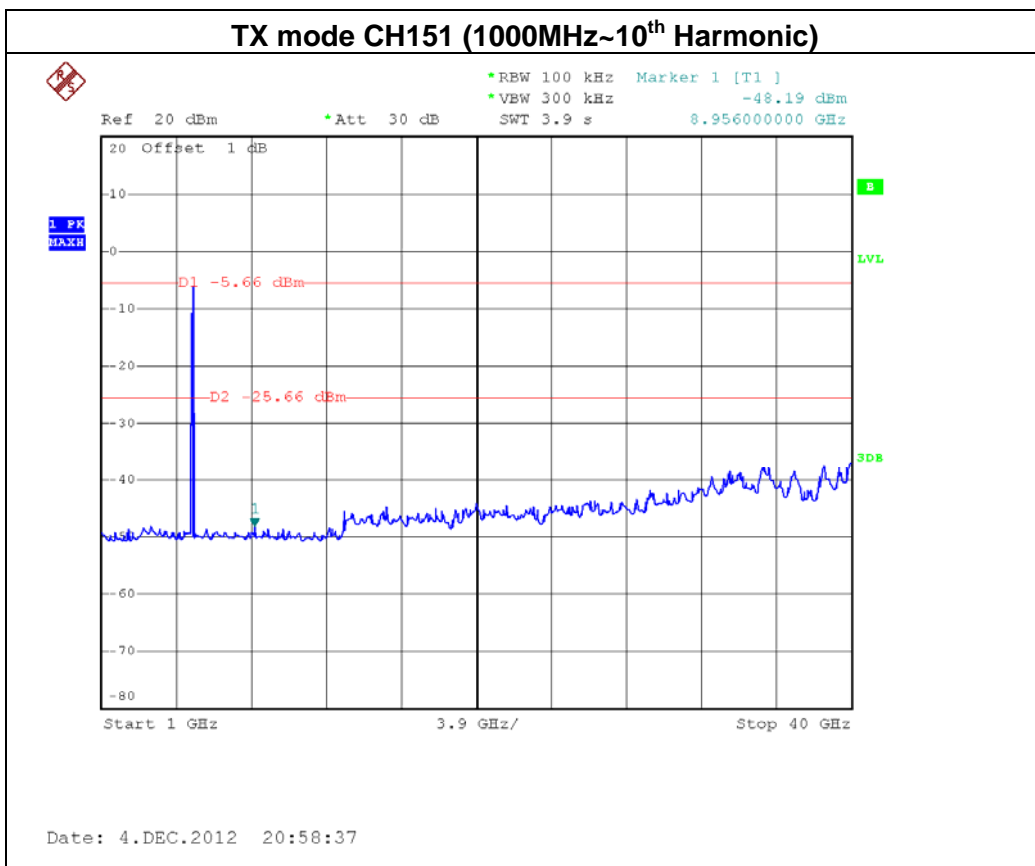
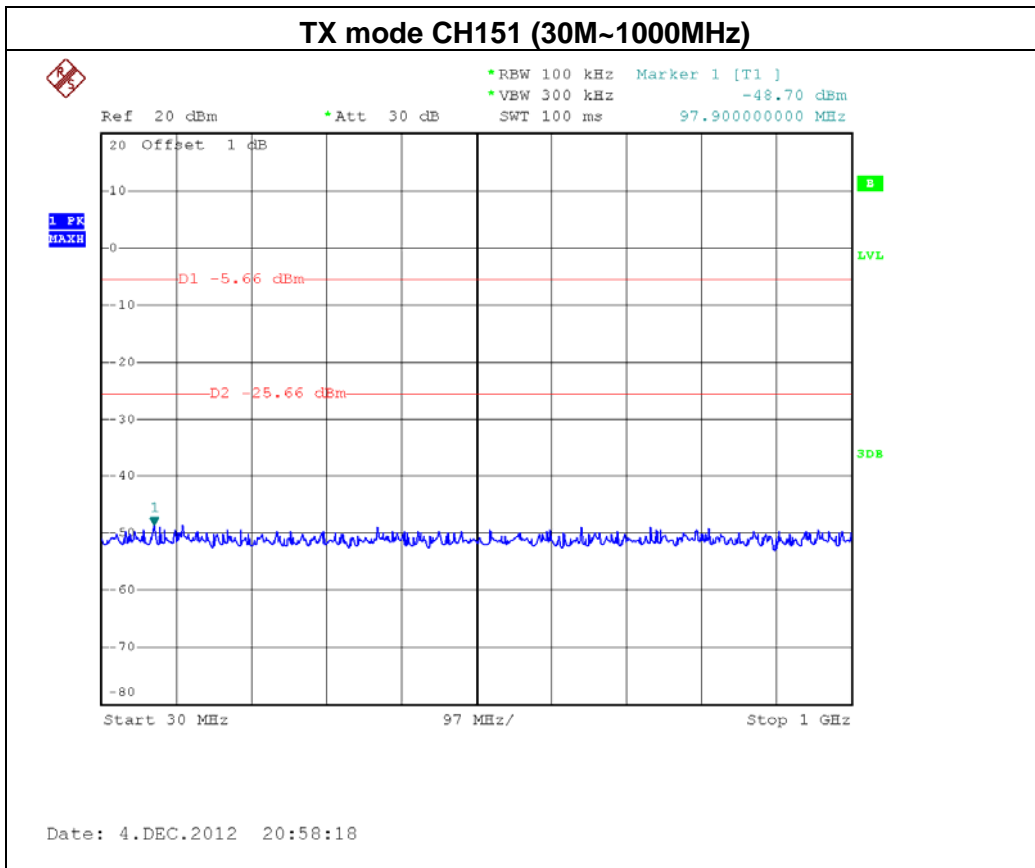

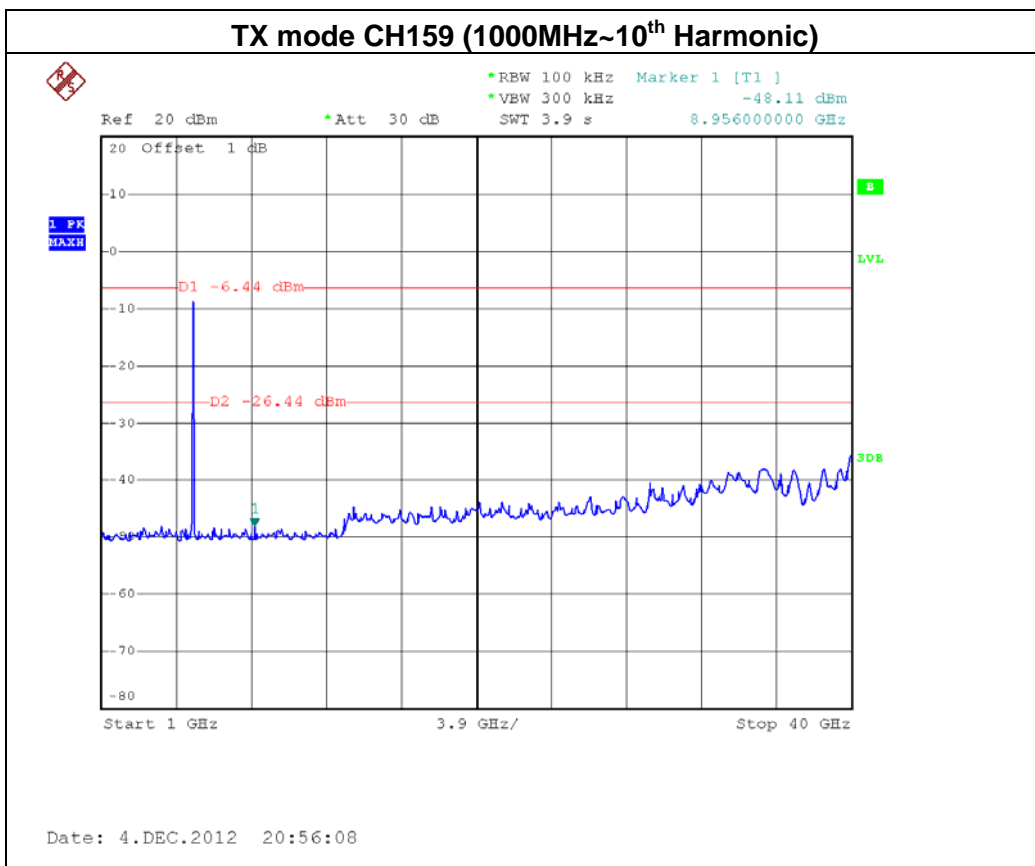
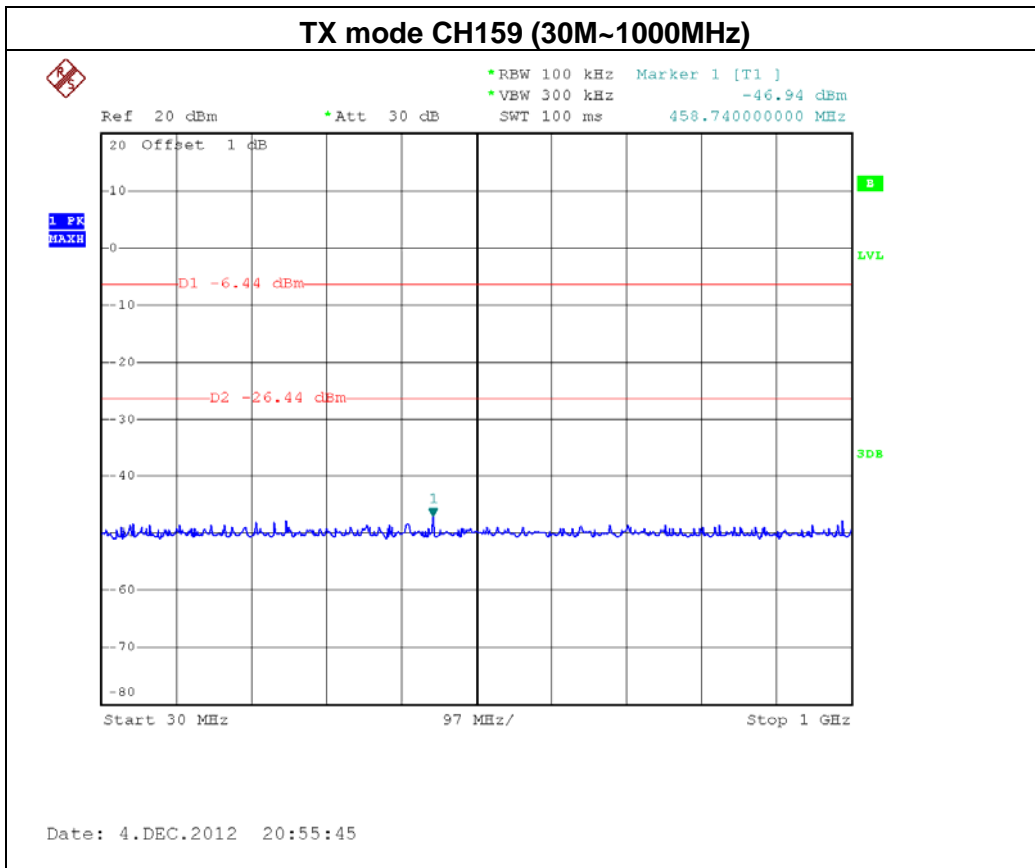



EUT :	Wireless Dual Band Router	Model Name :	WF2471
Temperature :	25 °C	Relative Humidity :	58 %
Pressure :	1010 hPa	Test Voltage :	AC 120V/60Hz
Test Mode :	TX N40 Mode /CH151, CH159-ANT 2		

Channel of Worst Data: CH151			
The max. radio frequency power in any 100kHz bandwidth outside the frequency band		The max. radio frequency power in any 100 kHz bandwidth within the frequency band.	
FREQUENCY(MHz)	POWER(dBm)	FREQUENCY(MHz)	POWER(dBm)
5721.20	-38.00	5853.20	-46.99
Result			
In any 100kHz bandwidth outside the frequency band, the radio frequency power is at least 20dB below that in the 100kHz bandwidth within the band that contains the highest level of the desired power.			

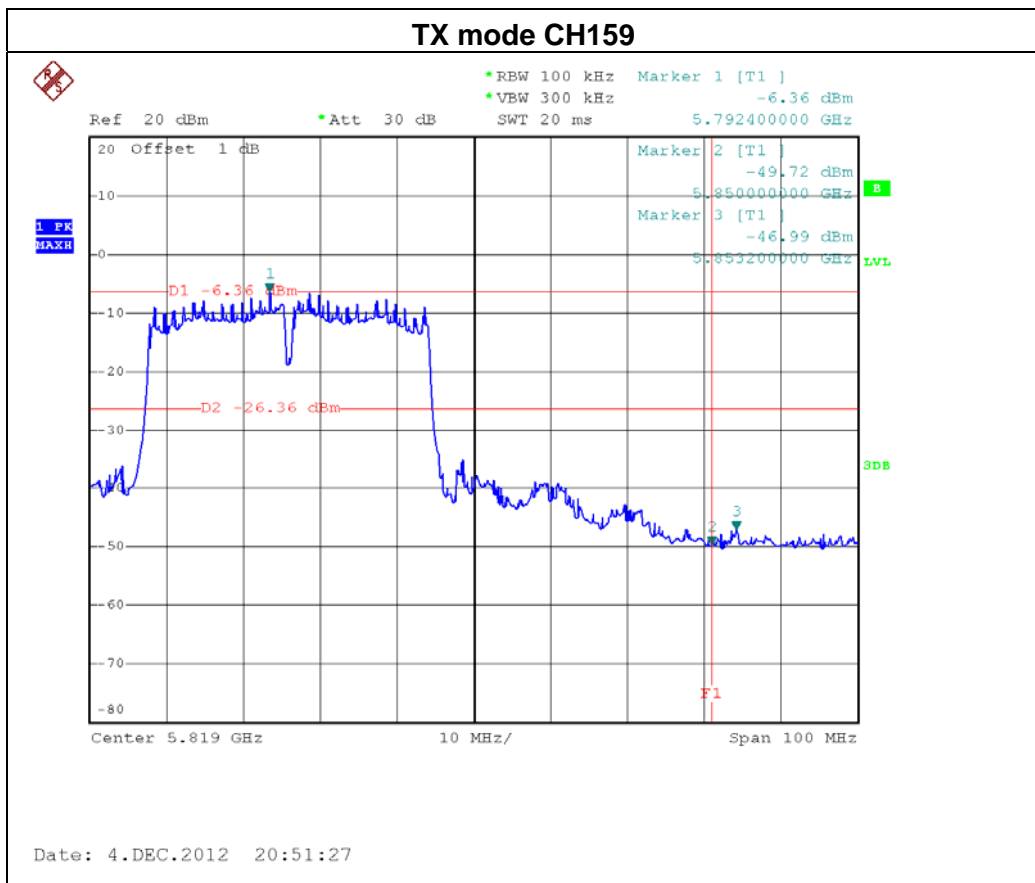
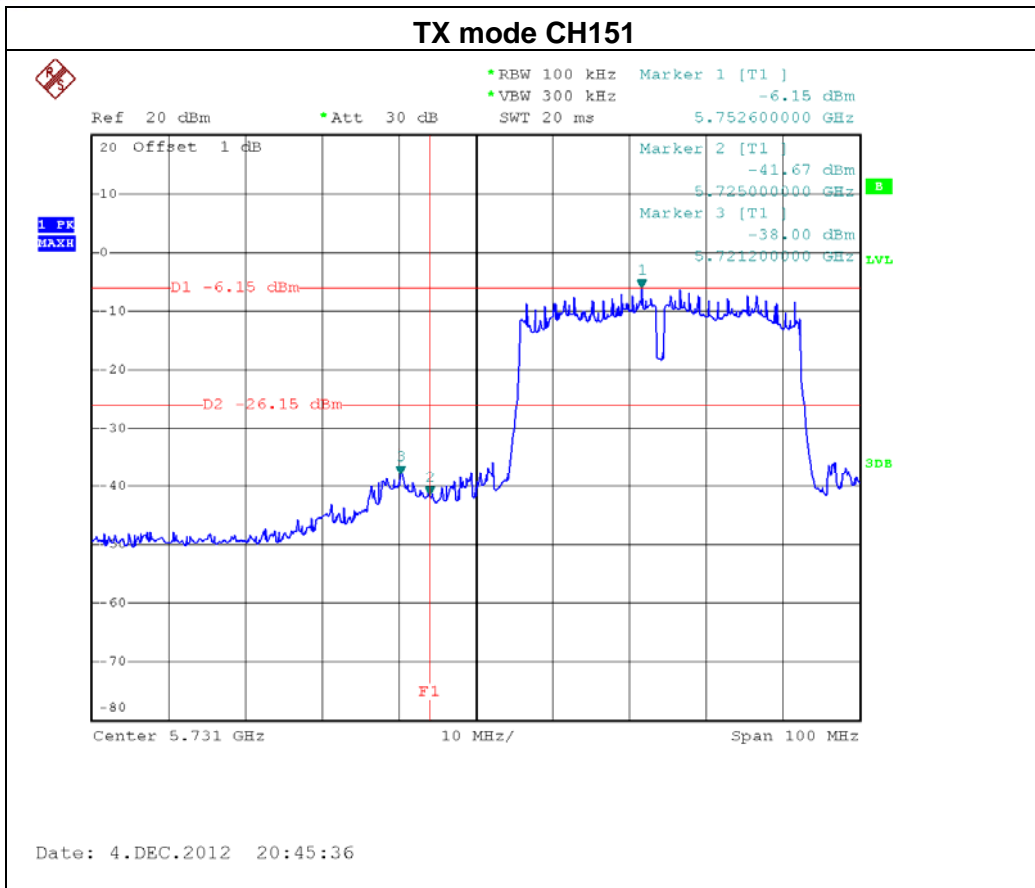

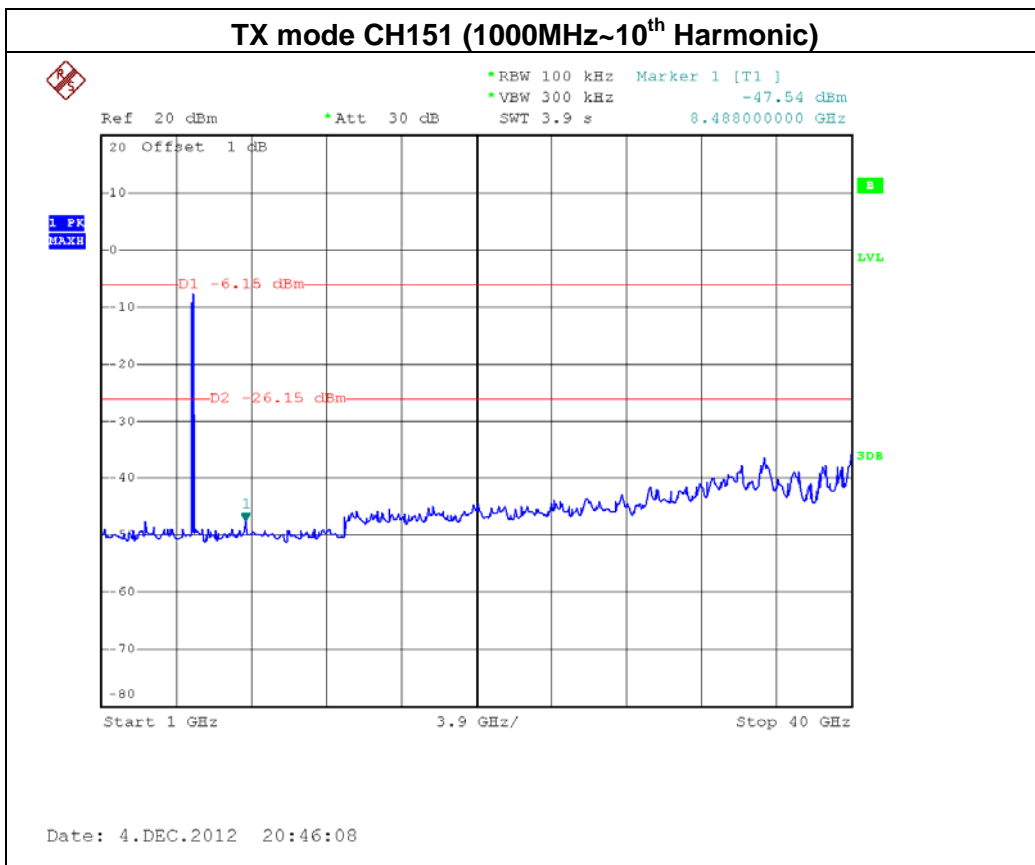
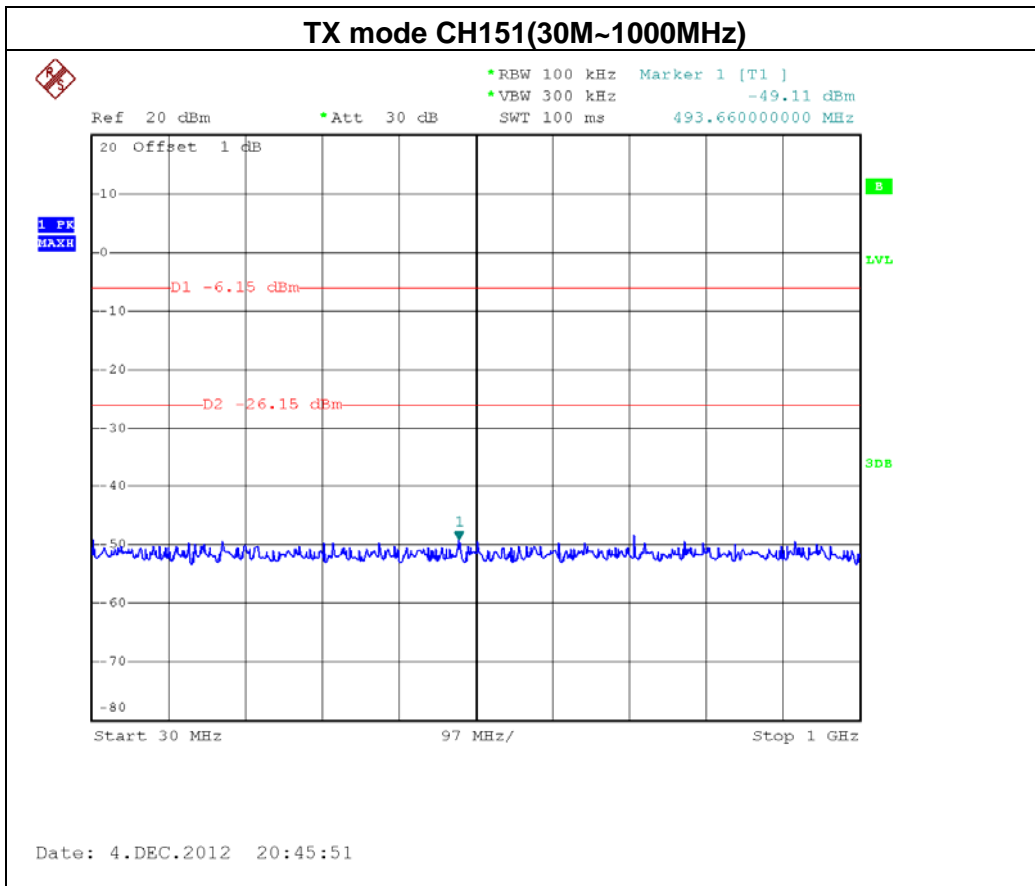

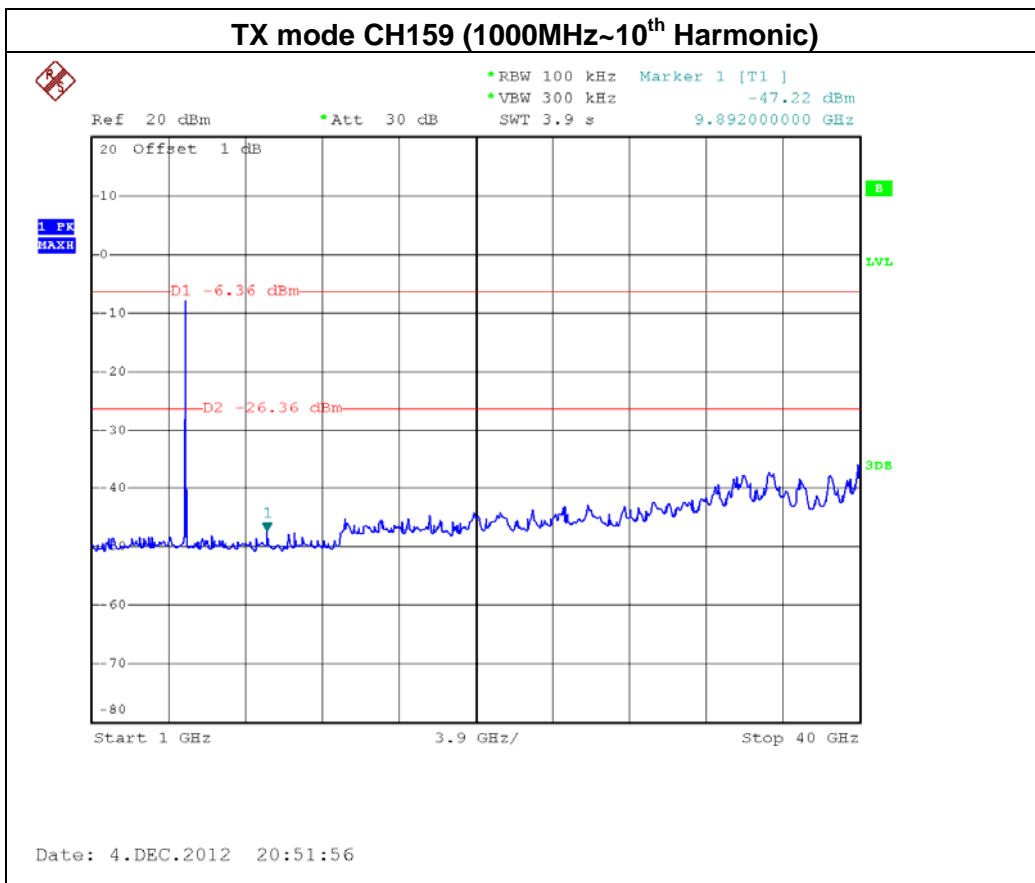
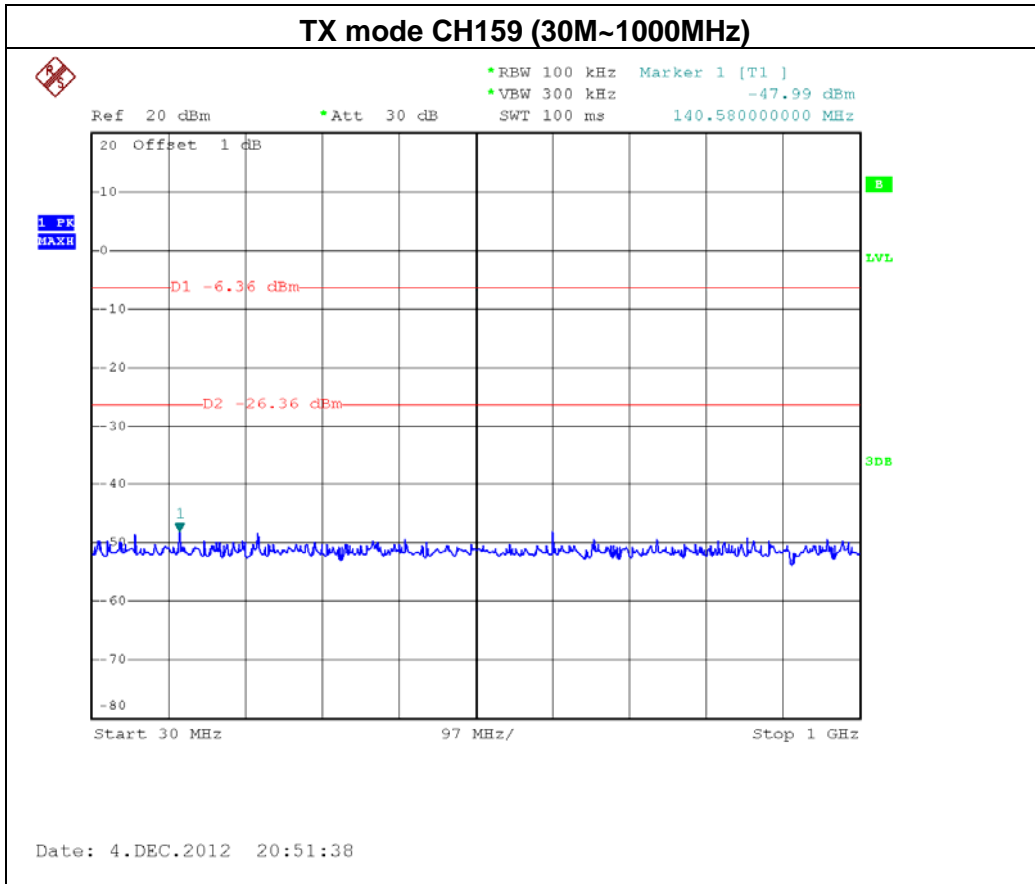



8. POWER SPECTRAL DENSITY TEST

8.1 Applied procedures / limit

FCC Part15 (15.247) , Subpart C				
Section	Test Item	Limit	Frequency Range (MHz)	Result
15.247(e)	Power Spectral Density	8 dBm (in any 3KHz)	5745 - 5825	PASS

8.1.1 MEASUREMENT INSTRUMENTS LIST

Item	Kind of Equipment	Manufacturer	Type No.	Serial No.	Last Calibration	Next Calibration
1	Spectrum Analyzer	R&S	FSP_40	100185	Nov.25.2012	Nov.16.2013

Remark: "N/A" denotes no model name, serial no. or calibration specified.
 All calibration period of Equipment List is One Year.

8.1.2 TEST PROCEDURE

- a. The EUT was directly connected to the spectrum analyzer and antenna output port as show in the block diagram below,
- b. Spectrum Setting : RBW=100KHz, VBW=300 KHz, Sweep time = auto.

8.1.3 DEVIATION FROM STANDARD

No deviation.

8.1.4 TEST SETUP

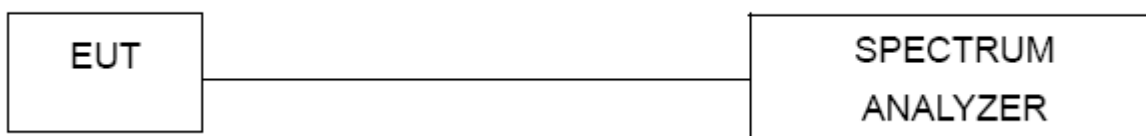

8.1.5 EUT OPERATION CONDITIONS

The EUT tested system was configured as the statements of 4.1.6 Unless otherwise a special operating condition is specified in the follows during the testing.

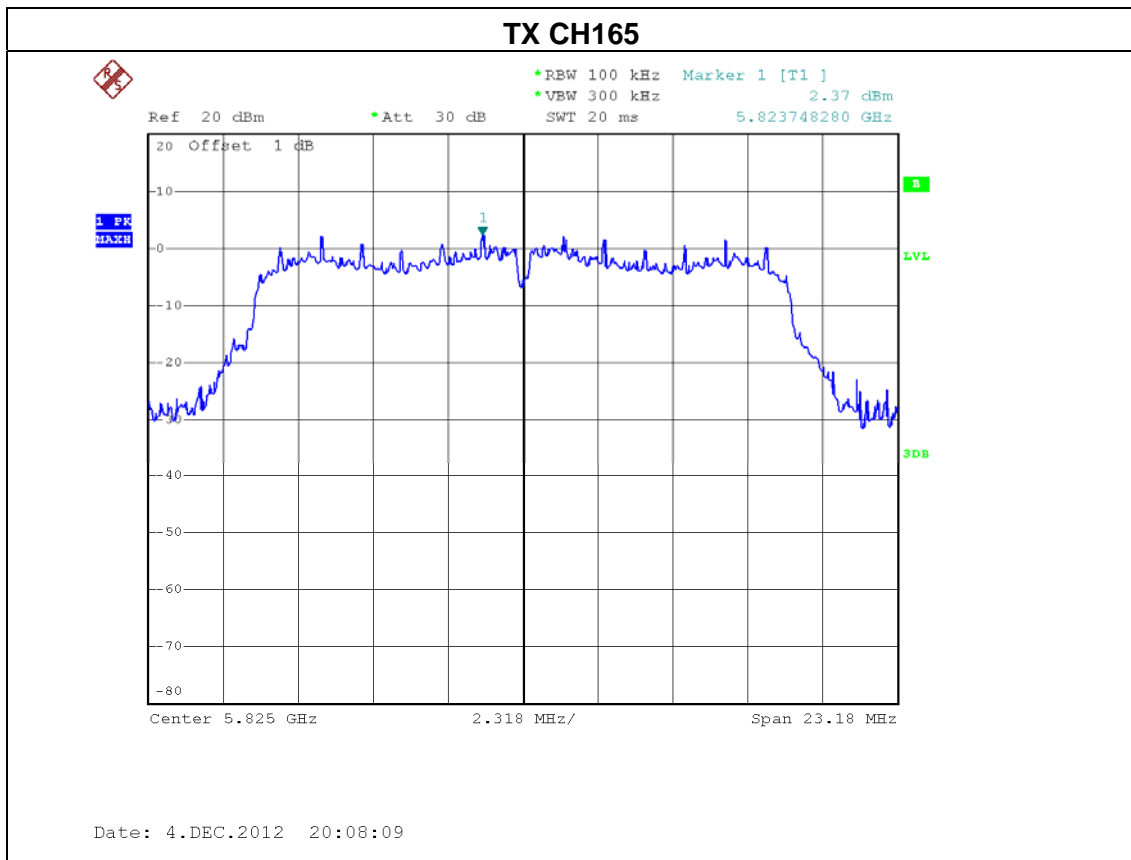
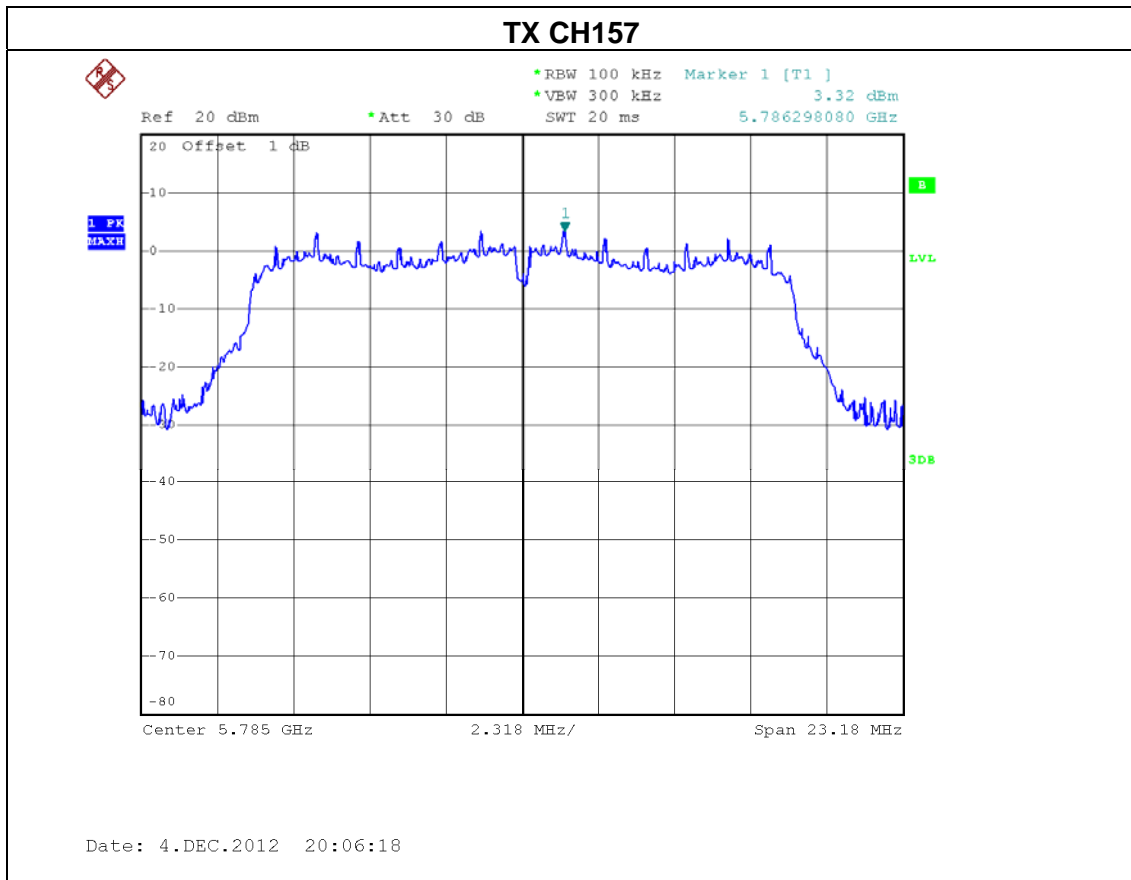



EUT :	Wireless Dual Band Router	Model Name :	WF2471
Temperature :	23 °C	Relative Humidity :	51 %
Pressure :	1010 hPa	Test Voltage :	AC 120V/60Hz
Test Mode :	TX N20 Mode /CH149, CH157, CH165		

ANT 1			
Test Channel	Frequency (MHz)	Power Density (dBm)	LIMIT (dBm)
CH149	5745 MHz	-15.52	8
CH157	5785 MHz	-15.35	8
CH165	5825 MHz	-15.96	8

ANT 2			
Test Channel	Frequency (MHz)	Power Density (dBm)	LIMIT (dBm)
CH149	5745 MHz	-16.87	8
CH157	5785 MHz	-15.69	8
CH165	5825 MHz	-15.80	8

ANT 1+ANT 2			
Test Channel	Frequency (MHz)	Power Density (dBm)	LIMIT (dBm)
CH149	5745 MHz	-13.13	6.42
CH157	5785 MHz	-12.51	6.42
CH165	5825 MHz	-12.87	6.42

Note: DWCF (dB) = 10 log (3K/100K) = -15.22dB

Remark :

- (1) **The MIMO test requirement, RF conducted output power shall measure each transmitter chain by using channel power method.**
And after obtain each individual transmitter chain power, then sum the output power by using the following formula:

$$((\text{dBm}/\text{Chain 1})/10^{\wedge}\text{Log}) + ((\text{dBm}/\text{Chain 2})/10^{\wedge}\text{log}) + ((\text{dBm}/\text{ChainN})/10^{\wedge}\text{log}) =$$
Combined peak output power in mW.
- (2) **Antenna Gain=4.58 dBi.**
- (3) This EUT supports MIMO 2T2R, all transmit signals are completely uncorrelated, then,

$$\text{Directional gain} = G_{\text{ANT}} + 10 \log(\text{N}) \text{ dBi}$$
, that is Directional gain=7.58; So,the out power limit is 30-7.58+6=28.42; and power density limit is 8-7.58+6=6.42

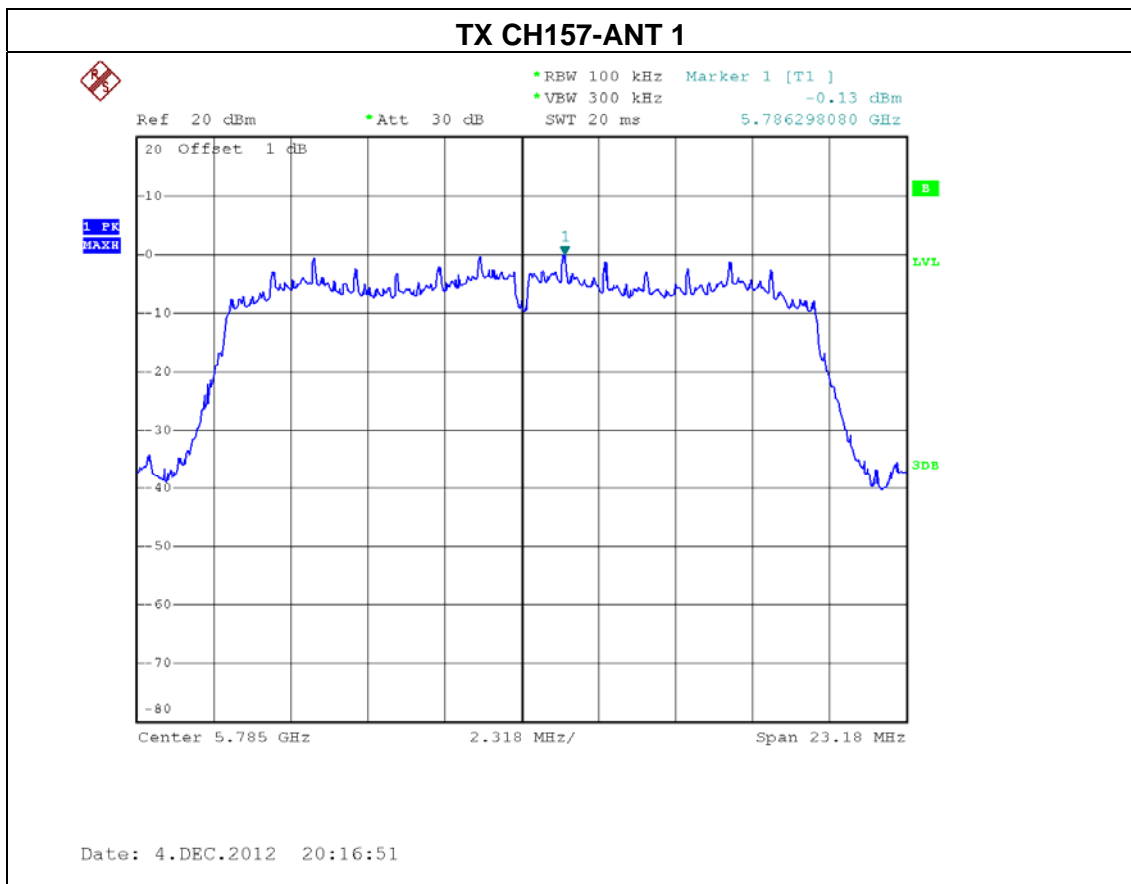
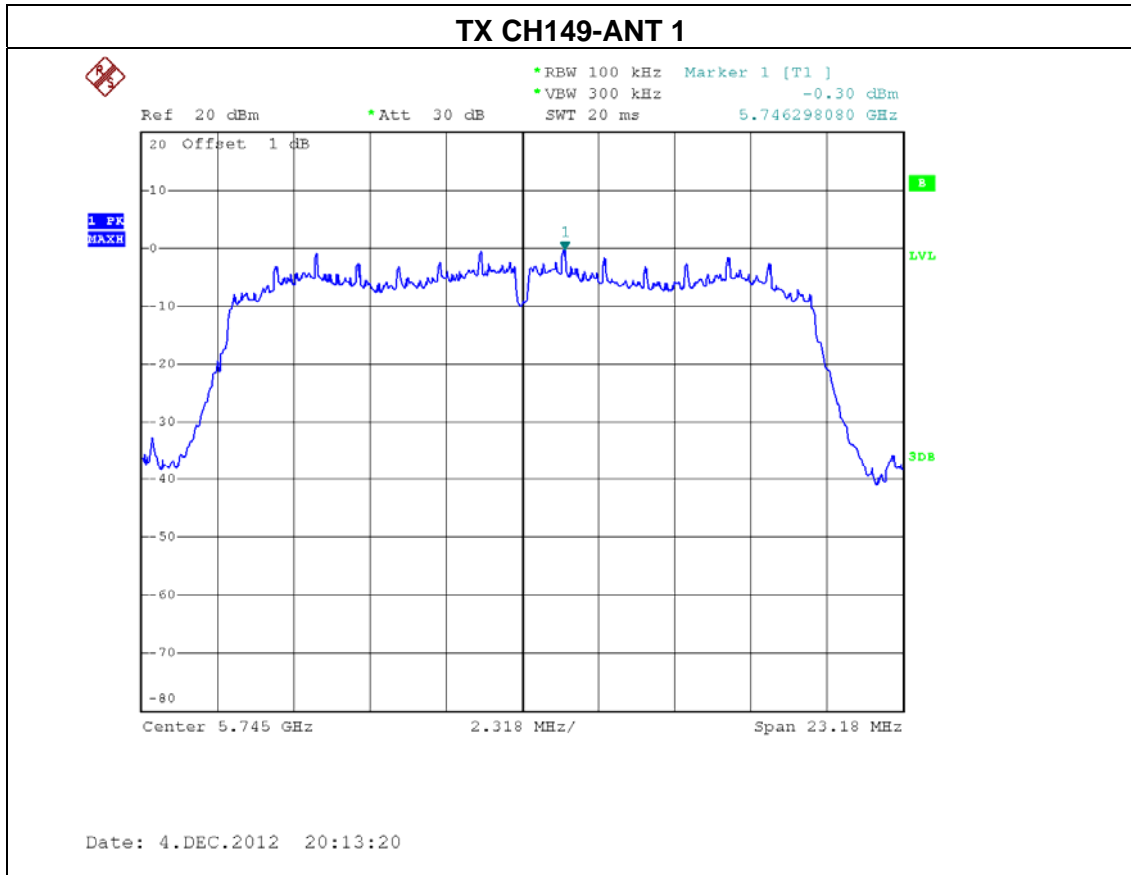



TX CH165-ANT 1

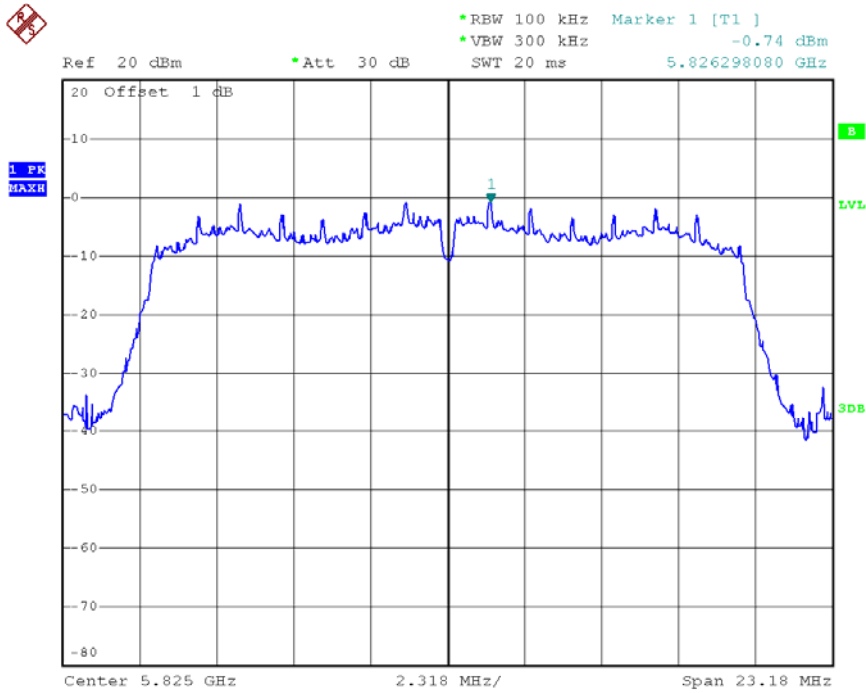

Date: 4.DEC.2012 20:19:07

TX CH149-ANT 2

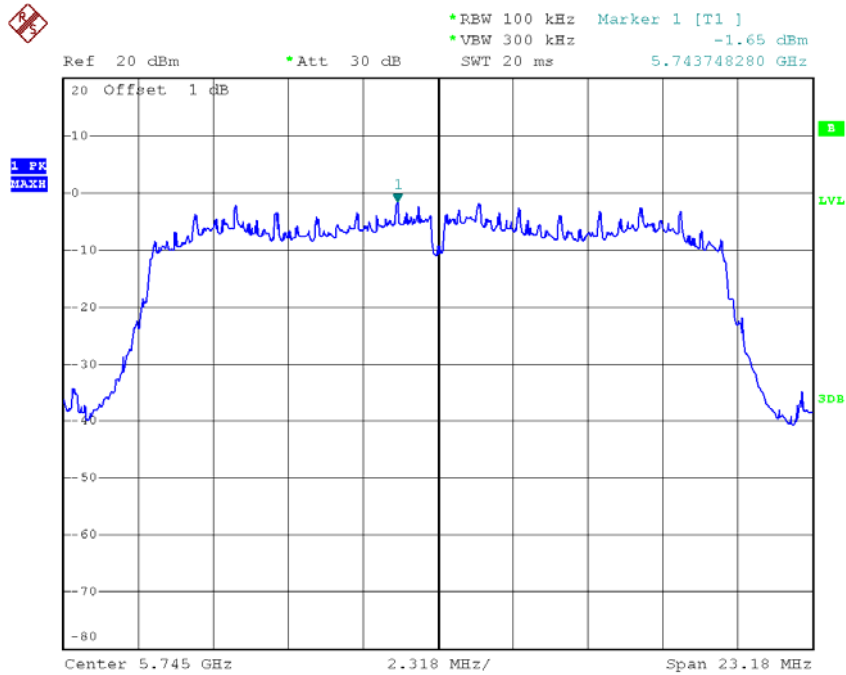

Date: 4.DEC.2012 20:41:09



EUT :	Wireless Dual Band Router	Model Name :	WF2471
Temperature :	23 °C	Relative Humidity :	51 %
Pressure :	1010 hPa	Test Voltage :	AC 120V/60Hz
Test Mode :	TX N40 Mode /CH151, CH159		

ANT 1			
Test Channel	Frequency (MHz)	Power Density (dBm)	LIMIT (dBm)
CH151	5755 MHz	-20.92	8
CH159	5795 MHz	-21.63	8

ANT 2			
Test Channel	Frequency (MHz)	Power Density (dBm)	LIMIT (dBm)
CH151	5755 MHz	-21.52	8
CH159	5795 MHz	-21.52	8

ANT 1+ ANT 2			
Test Channel	Frequency (MHz)	Power Density (dBm)	LIMIT (dBm)
CH151	5755 MHz	-18.20	6.42
CH159	5795 MHz	-18.56	6.42

Note: DWCF (dB) = 10 log (3K/100K) = -15.2dB

Remark :

- (1) **The MIMO test requirement, RF conducted output power shall measure each transmitter chain by using channel power method.**
And after obtain each individual transmitter chain power, then sum the output power by using the following formula:

$$((\text{dBm}/\text{Chain 1})/10^{\text{Log}}) + ((\text{dBm}/\text{Chain 2})/10^{\text{log}}) + ((\text{dBm}/\text{Chain N})/10^{\text{log}}) =$$
Combined peak output power in mW.
- (2) **Antenna Gain=4.58 dBi.**
- (3) This EUT supports MIMO 2T2R, all transmit signals are completely uncorrelated, then, **Directional gain = $G_{ANT} + 10 \log(N)$ dBi**, that is Directional gain=7.58; So, the out power limit is 30-7.58+6=28.42; and power density limit is 8-7.58+6=6.42

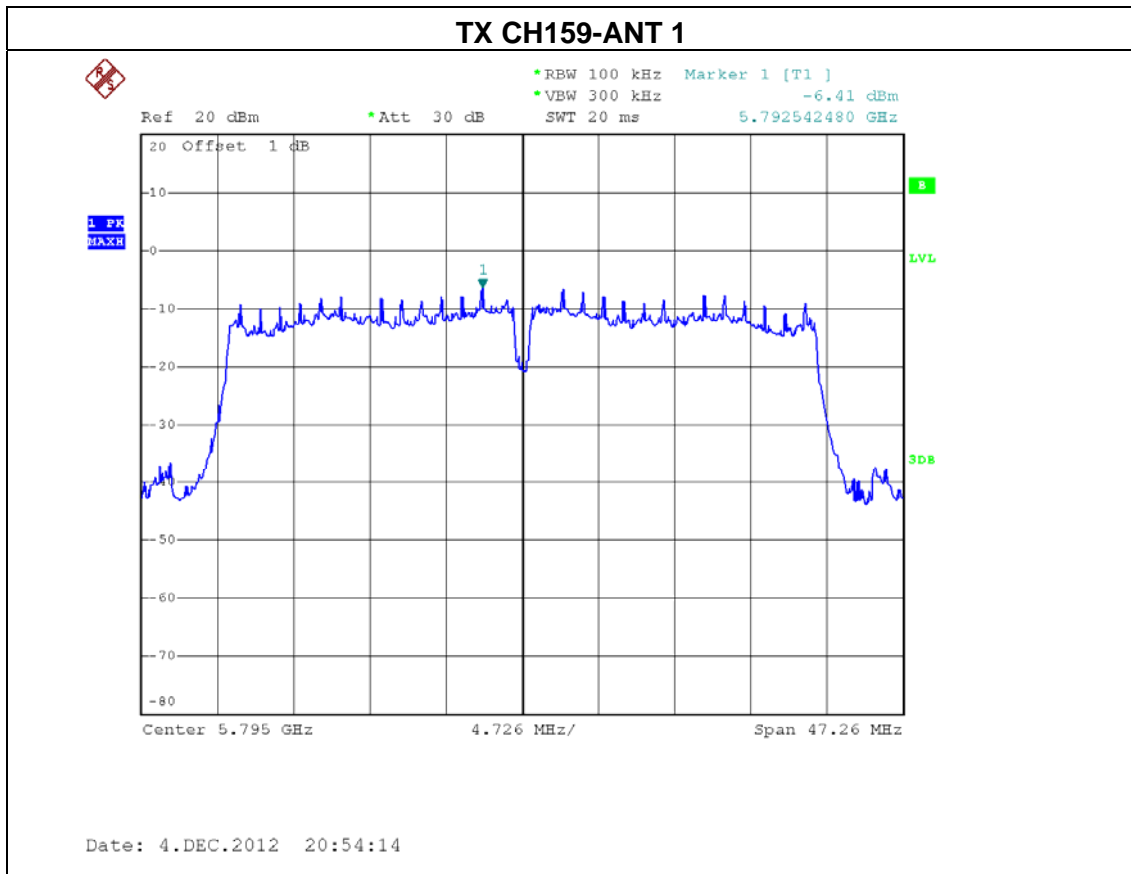
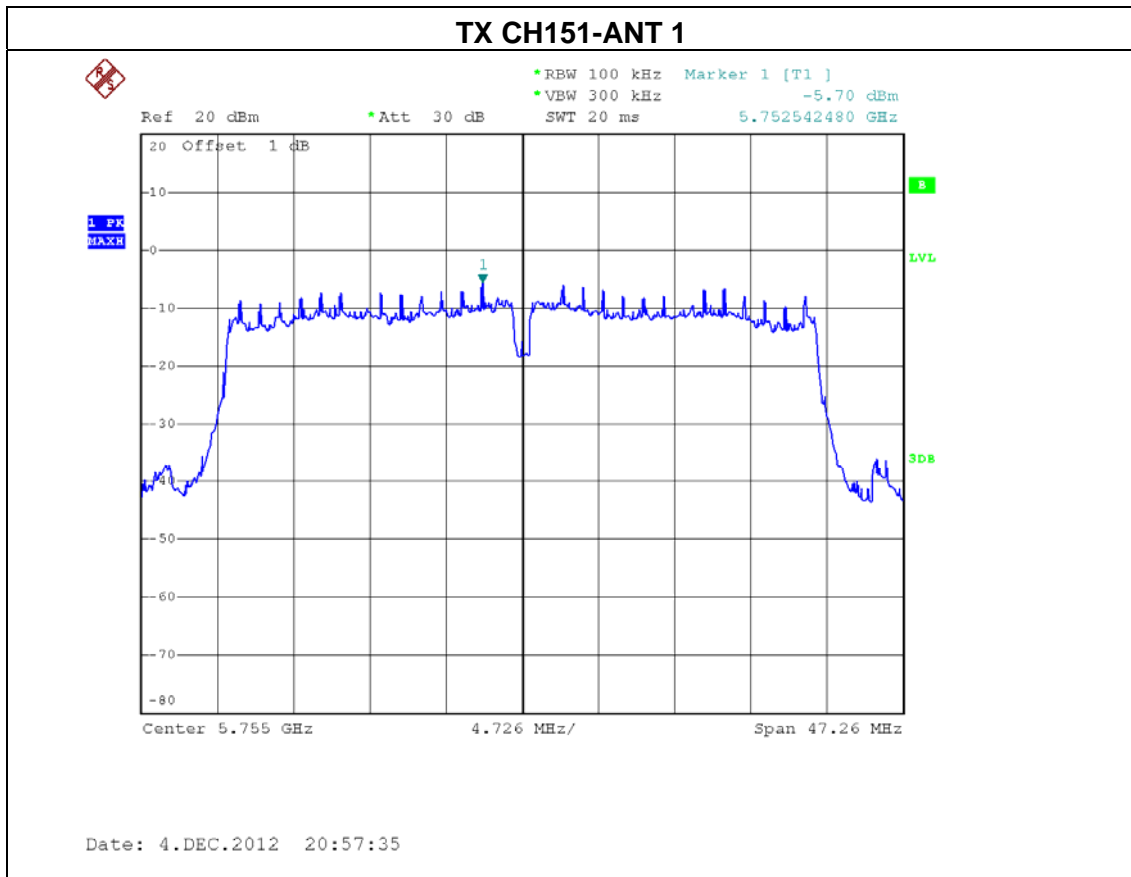

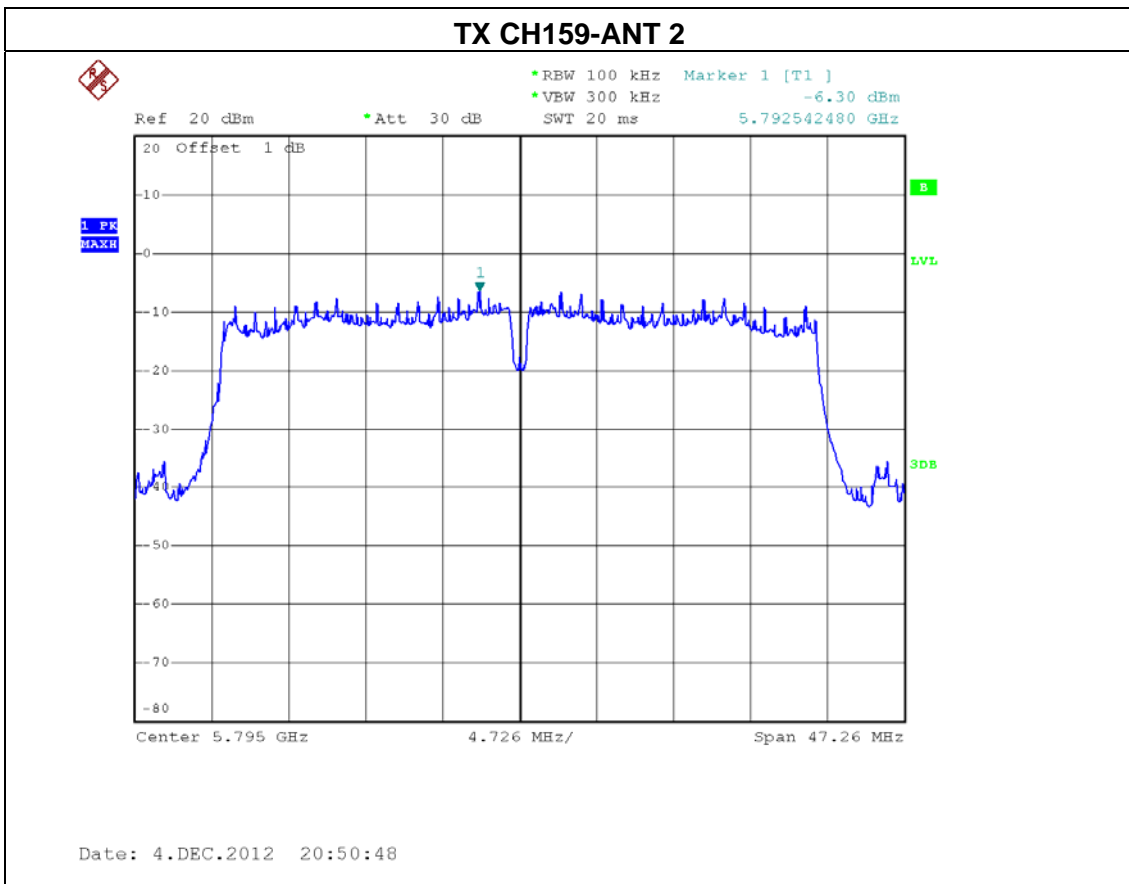
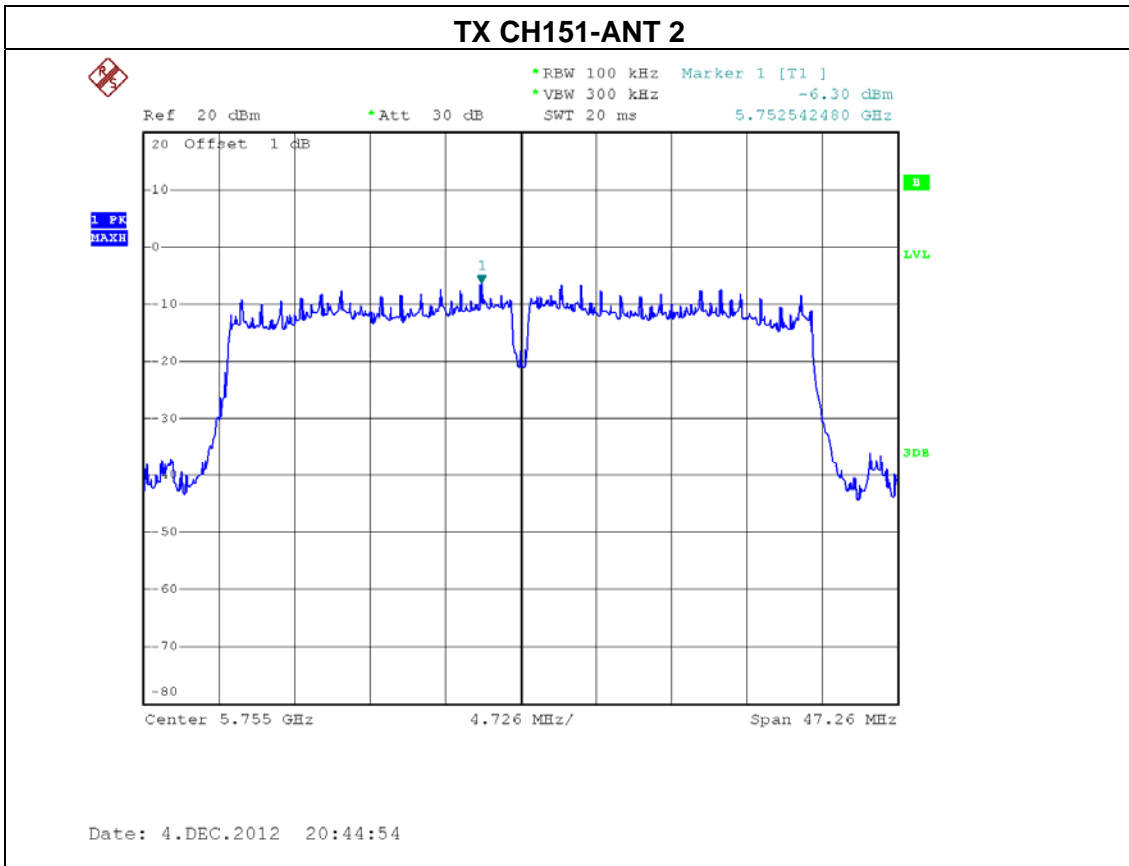

9. EUT TEST PHOTO

Conducted Measurement Photos



Radiated Measurement Photos

