



TEST REPORT

Report Reference No...... : **TRE1807010301** R/C.....: **30219**

FCC ID..... : **T58W2R**

Applicant's name..... : **NETIS SYSTEMS CO., LTD.**

Address.....: Building 6, Baolong Plant, Able Technology Park, Longgang District, Shenzhen, China

Manufacturer.....: **NETIS SYSTEMS CO., LTD.**

Address.....: Building 6, Baolong Plant, Able Technology Park, Longgang District, Shenzhen, China

Test item description : **300Mbps Wireless N Router**

Trade Mark: netis

Model/Type reference.....: W2

Listed Model(s): -

Standard : **FCC CFR Title 47 Part 15 Subpart C Section 15.247**

Date of receipt of test sample.....: Jul.18,2018

Date of testing.....: Jul.18,2018 ~ Jul.31,2018

Date of issue.....: Aug.02,2018

Result.....: **PASS**

Compiled by
(position+printed name+signature)...: File administrators Yueming Li

Yueming.Li

Supervised by
(position+printedname+signature).....: Project Engineer Tom Ouyang

Tom ouyang

Approved by
(position+printedname+signature).....: RF Manager Hans Hu

Hans Hu

Testing Laboratory Name : **Shenzhen Huatongwei International Inspection Co., Ltd.**

Address.....: 1/F, Bldg 3, Hongfa Hi-tech Industrial Park, Genyu Road, Tianliao, Gongming, Shenzhen, China

Shenzhen Huatongwei International Inspection Co., Ltd. All rights reserved.

This publication may be reproduced in whole or in part for non-commercial purposes as long as the Shenzhen Huatongwei International Inspection Co., Ltd. is acknowledged as copyright owner and source of the material. Shenzhen Huatongwei International Inspection Co., Ltd. takes no responsibility for and will not assume liability for damages resulting from the reader's interpretation of the reproduced material due to its placement and context.

The test report merely correspond to the test sample.

Contents

1.	TEST STANDARDS AND REPORT VERSION	3
1.1.	Test Standards	3
1.2.	Report Version	3
2.	TEST DESCRIPTION	4
3.	SUMMARY	5
3.1.	Client Information	5
3.2.	Product Description	5
3.3.	Operation State	6
3.4.	EUT Configuration	7
3.5.	Modifications	7
4.	TEST ENVIRONMENT	8
4.1.	Address of the test laboratory	8
4.2.	Test Facility	8
4.3.	Environmental Conditions	9
4.4.	Statement of the measurement uncertainty	9
4.5.	Equipments Used during the Test	10
5.	TEST CONDITIONS AND RESULTS	12
5.1.	Antenna Requirement	12
5.2.	Conducted Emissions (AC Main)	13
5.3.	Conducted Peak Output Power	16
5.4.	Power Spectral Density	17
5.5.	6dB Bandwidth	27
5.6.	Restricted Band	37
5.7.	Band Edge and Spurious Emissions (Conducted)	41
5.8.	Spurious Emissions (Radiated)	74
6.	TEST SETUP PHOTOS	错误!未定义书签。
7.	EXTERANAL AND INTERNAL PHOTOS	错误!未定义书签。

1. TEST STANDARDS AND REPORT VERSION

1.1. Test Standards

The tests were performed according to following standards:

[FCC Rules Part 15.247](#): Frequency Hopping, Direct Spread Spectrum and Hybrid Systems that are in operation within the bands of 902-928 MHz, 2400-2483.5 MHz, and 5725-5850 MHz.

[ANSI C63.10:2013](#): American National Standard for Testing Unlicensed Wireless Devices

[KDB 558074 D01 DTS Meas Guidance v04](#): Guidance for Performing Compliance Measurements on Digital Transmission Systems (DTS) Operating under §15.247

[KDB662911 D01 Multiple Transmitter Output v02r01](#): Emissions Testing of Transmitters with Multiple Outputs in the Same Band (e.g., MIMO, Smart Antenna, etc)

[KDB662911 D02 MIMO with Cross-Polarized Antennas v01](#): MIMO with Cross-Polarized Antenna

1.2. Report Version

Version No.	Date of issue	Description
N/A	2018-07-31	Original

2. TEST DESCRIPTION

Test Item	FCC Rule	Result	Test Engineer
Antenna requirement	15.203/15.247(c)	Pass	Xiaokang Tan
Line Conducted Emissions (AC Main)	15.207	Pass	Tony Duan
Conducted Peak Output Power	15.247(b)(3)	Pass	Xiaokang Tan
Power Spectral Density	15.247(e)	Pass	Xiaokang Tan
6dB Bandwidth	15.247(a)(2)	Pass	Xiaokang Tan
Restricted band	15.247(d)/15.205	Pass	Xiaokang Tan
Spurious Emissions	15.247(d)/15.209	Pass	Jiuru Pan

Note: The measurement uncertainty is not included in the test result.

3. SUMMARY

3.1. Client Information

Applicant:	NETIS SYSTEMS CO., LTD.
Address:	Building 6, Baolong Plant, Able Technology Park, Longgang District, Shenzhen, China
Manufacturer:	NETIS SYSTEMS CO., LTD.
Address:	Building 6, Baolong Plant, Able Technology Park, Longgang District, Shenzhen, China

3.2. Product Description

Name of EUT:	300Mbps Wireless N Router
Trade Mark:	netis
Model No.:	W2
Listed Model(s):	-
Power supply:	DC 9V from adapter
Adapter 1 information:	Model:AMS195-0900600FU Input:100-240V ~ 50/60Hz 0.3A Output:9Vd.c. 600mA
Adapter 2 information:	Model:NTT97090050UL Input:100-240V ~ 50/60Hz 0.3A Output:9Vd.c. 500mA
Hardware version:	PB-7187
Software version:	V2.2.6744
WIFI	
Supported type:	802.11b/802.11g/802.11n(HT20)/802.11n(HT40)
Modulation:	DSSS for 802.11b OFDM for 802.11g/802.11n(HT20)/802.11n(HT40)
Operation frequency:	2412MHz~2462MHz for 802.11b/802.11g/802.11n(HT20) 2422MHz~2452MHz for 802.11n(HT40)
Channel number:	11 for 802.11b/802.11g/802.11n(HT20) 7 for 802.11n(HT40)
Channel separation:	5MHz
Antenna number:	Dipole Antenna
Antenna gain:	5dBi

3.3. Operation State

➤ Test frequency list

According to section 15.31(m), regards to the operating frequency range over 10 MHz, must select three channel which were tested. the Lowest frequency, the middle frequency, and the highest frequency of channel were selected to perform the test, please see the above gray bottom.

802.11b/g/n(HT20)		802.11n(HT40)	
Channel	Frequency (MHz)	Channel	Frequency (MHz)
01	2412	01	-
02	2417	02	-
03	2422	03	2422
04	2427	04	2427
05	2432	05	2432
06	2437	06	2437
07	2442	07	2442
08	2447	08	2447
09	2452	09	2452
10	2457	10	-
11	2462	11	-

Per-scan all kind of data rate in lowest channel, and found the follow list which it was worst case.

Mode	Data rate	Tune-up Conducted peak power(dBm)
802.11b	1 Mbps	15.00-17.00
802.11g	6 Mbps	15.00-17.00
802.11n(HT20)/n(HT40)	MCS0	16.00-18.00

➤ Test mode

For RF test items
The engineering test program was provided and enabled to make EUT continuous transmit (duty cycle>98%).
For AC power line conducted emissions:
The EUT was set to connect with the WLAN AP under large package sizes transmission.
For RF test axis
EUT in each of three orthogonal axis emissions had been tested ,but only the worst case (X axis) data Recorded in the report.

3.4. EUT Configuration

The following peripheral devices and interface cables were connected during the measurement:

- - supplied by the manufacturer
- - supplied by the lab

○ /	Manufacturer:	/
	Model No.:	/
○ /	Manufacturer:	/
	Model No.:	/

3.5. Modifications

No modifications were implemented to meet testing criteria.

4. TEST ENVIRONMENT

4.1. Address of the test laboratory

Laboratory: Shenzhen Huatongwei International Inspection Co., Ltd.

Address: 1/F, Bldg 3, Hongfa Hi-tech Industrial Park, Genyu Road, Tianliao, Gongming, Shenzhen, China

4.2. Test Facility

CNAS-Lab Code: L1225

Shenzhen Huatongwei International Inspection Co., Ltd. has been assessed and proved to be in compliance with CNAS-CL01 Accreditation Criteria for Testing and Calibration Laboratories (identical to ISO/IEC17025: 2005 General Requirements) for the Competence of Testing and Calibration Laboratories.

A2LA-Lab Cert. No.: 3902.01

Shenzhen Huatongwei International Inspection Co., Ltd. EMC Laboratory has been accredited by A2LA for technical competence in the field of electrical testing, and proved to be in compliance with ISO/IEC 17025: 2005 General Requirements for the Competence of Testing and Calibration Laboratories and any additional program requirements in the identified field of testing.

FCC-Registration No.: 762235

Shenzhen Huatongwei International Inspection Co., Ltd. EMC Laboratory has been registered and fully described in a report filed with the FCC (Federal Communications Commission). The acceptance letter from the FCC is maintained in our files.

IC-Registration No.:5377B-1

Two 3m Alternate Test Site of Shenzhen Huatongwei International Inspection Co., Ltd. has been registered by Certification and Engineering Bureau of Industry Canada for the performance of radiated measurements with Registration No.: 5377B-1.

ACA

Shenzhen Huatongwei International Inspection Co., Ltd. EMC Laboratory can also perform testing for the Australian C-Tick mark as a result of our A2LA accreditation.

4.3. Environmental Conditions

During the measurement the environmental conditions were within the listed ranges:

Temperature:	15~35°C
Relative Humidity:	30~60 %
Air Pressure:	950~1050mba

4.4. Statement of the measurement uncertainty

The data and results referenced in this document are true and accurate. The reader is cautioned that there may be errors in calibration limits of the equipment and facilities. The measurement uncertainty was calculated for all measurements listed in this test report according to TR-100028-01 "Electromagnetic compatibility and Radio spectrum Matters (ERM); Uncertainties in the measurement of mobile radio equipment characteristics; Part 1" and TR-100028-02 "Electromagnetic compatibility and Radio spectrum Matters (ERM); Uncertainties in the measurement of mobile radio equipment characteristics; Part 2" and is documented in the Shenzhen Huatongwei International Inspection Co., Ltd. quality system according to ISO/IEC 17025. Furthermore, component and process variability of devices similar to that tested may result in additional deviation. The manufacturer has the sole responsibility of continued compliance of the device.

Here after the best measurement capability for Shenzhen Huatongwei International Inspection Co., Ltd. is reported:

Test Items	Measurement Uncertainty	Notes
Transmitter power conducted	0.57 dB	(1)
Transmitter power Radiated	2.20 dB	(1)
Conducted spurious emissions 9kHz~40GHz	1.60 dB	(1)
Radiated spurious emissions 9kHz~40GHz	2.20 dB	(1)
Conducted Emissions 9kHz~30MHz	3.39 dB	(1)
Radiated Emissions 30~1000MHz	4.24 dB	(1)
Radiated Emissions 1~18GHz	5.16 dB	(1)
Radiated Emissions 18~40GHz	5.54 dB	(1)

(1) This uncertainty represents an expanded uncertainty expressed at approximately the 95% confidence level using a coverage factor of $k=1.96$.

4.5. Equipments Used during the Test

Conducted Emissions						
Item	Test Equipment	Manufacturer	Model No.	Serial No.	Last Cal. (mm-dd-yy)	Next Cal. (mm-dd-yy)
1	EMI Test Receiver	R&S	ESCI	101247	11/11/2017	11/10/2018
2	Artificial Mains	SCHWARZBECK	NNLK 8121	573	11/11/2017	11/10/2018
3	Pulse Limiter	R&S	ESH3-Z2	101488	11/11/2017	11/10/2018
4	Test Software	R&S	ES-K1	N/A	N/A	N/A
5	RF Connection Cable	HUBER+SUHNER	EF400	N/A	11/21/2017	11/20/2018
6	Single Balanced Telecom Pair ISN	FCC	FCC-TLISN-T2-02	20371	11/11/2017	11/10/2018
7	Two Balanced Telecom Pairs ISN	FCC	FCC-TLISN-T4-02	20373	11/11/2017	11/10/2018
8	Four Balanced Telecom Pairs ISN	FCC	FCC-TLISN-T8-02	20375	11/11/2017	11/10/2018
9	V-Network	R&S	ESH3-Z6	100211	11/11/2017	11/10/2018
10	V-Network	R&S	ESH3-Z6	100210	11/11/2017	11/10/2018
11	2-Line V-Network	R&S	ESH3-Z5	100049	11/11/2017	11/10/2018

Radiated Emissions						
Item	Test Equipment	Manufacturer	Model No.	Serial No.	Last Cal. (mm-dd-yy)	Next Cal. (mm-dd-yy)
1	EMI Test Receiver	R&S	ESCI	101247	11/11/2017	11/10/2018
2	Loop Antenna	R&S	HFH2-Z2	100020	11/20/2017	11/19/2018
3	Ultra-Broadband Antenna	SCHWARZBECK	VULB9163	538	4/5/2017	4/4/2020
4	Horn Antenna	SCHWARZBECK	9120D	1011	3/27/2017	3/26/2020
5	Horn Antenna	SCHWARZBECK	BBHA9170	25841	3/27/2017	3/26/2020
6	Preamplifier	SCHWARZBECK	BBV 9743	9743-0022	10/18/2017	10/17/2018
7	Broadband Preamplifier	SCHWARZBECK	BBV 9718	9718-248	10/18/2017	10/17/2018
8	High pass filter	Compliance Direction systems	BSU-6	34202	11/11/2017	11/10/2018
9	Turntable	MATURO	TT2.0	/	N/A	N/A
10	Antenna Mast	MATURO	TAM-4.0-P	/	N/A	N/A

11	EMI Test Software	R&S	ESK1	N/A	N/A	N/A
12	EMI Test Software	Audix	E3	N/A	N/A	N/A
13	RF Connection Cable	HUBER+SUHNER	3m 3GHz S	N/A	11/21/2017	11/20/2018
14	RF Connection Cable	HUBER+SUHNER	3m 3GHz RG	N/A	11/21/2017	11/20/2018
15	RF Connection Cable	HUBER+SUHNER	6m 18GHz S	N/A	11/21/2017	11/20/2018

RF Conducted Test						
Item	Test Equipment	Manufacturer	Model No.	Serial No.	Last Cal. (mm-dd-yy)	Next Cal. (mm-dd-yy)
1	Spectrum Analyzer	R&S	FSV40	100048	11/11/2017	11/10/2018
2	EXA Signal Analyzer	Agilent	N9020A	184247	9/22/2017	9/21/2018
3	Power Meter	Anritsu	ML249A	N/A	9/22/2017	9/21/2018
4	OSP	R&S	OSP120	101317	N/A	N/A

5. TEST CONDITIONS AND RESULTS

5.1. Antenna Requirement

REQUIREMENT:

FCC CFR Title 47 Part 15 Subpart C Section 15.203:

An intentional radiator shall be designed to ensure that no antenna other than that furnished by the responsible party shall be used with the device. The use of a permanently attached antenna or of an antenna that uses a unique coupling to the intentional radiator, the manufacturer may design the unit so that a broken antenna can be replaced by the user, but the use of a standard antenna jack or electrical connector is prohibited.

FCC CFR Title 47 Part 15 Subpart C Section 15.247(c) (1)(i):

(i) Systems operating in the 2400~2483.5 MHz band that is used exclusively for fixed. Point-to-point operations may employ transmitting antennas with directional gain greater than 6 dBi provided the maximum conducted output power of the intentional radiator is reduced by 1 dB for every 3 dB that the directional gain of the antenna exceeds 6 dBi.

TEST RESULTS

Passed **Not Applicable**

Two irreplaceable antennas are soldered on the PCB board via the cable(antenna gain=5dBi)
The directional gain of the antenna less than 6 dBi, please refer to the below antenna photo.

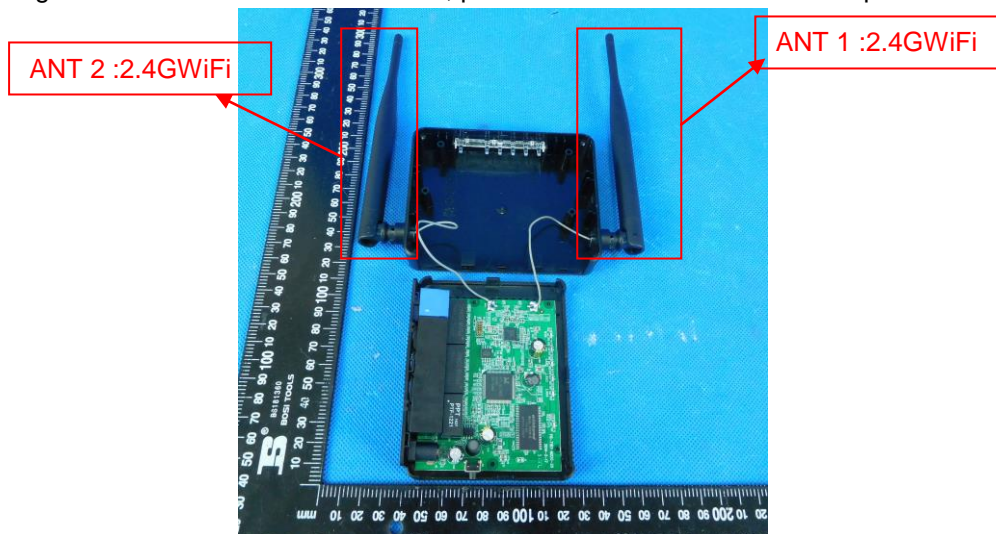

5.2. Conducted Emissions (AC Main)

LIMIT

FCC CFR Title 47 Part 15 Subpart C Section 15.207:

Frequency range (MHz)	Limit (dBuV)	
	Quasi-peak	Average
0.15-0.5	66 to 56*	56 to 46*
0.5-5	56	46
5-30	60	50

* Decreases with the logarithm of the frequency.

TEST CONFIGURATION

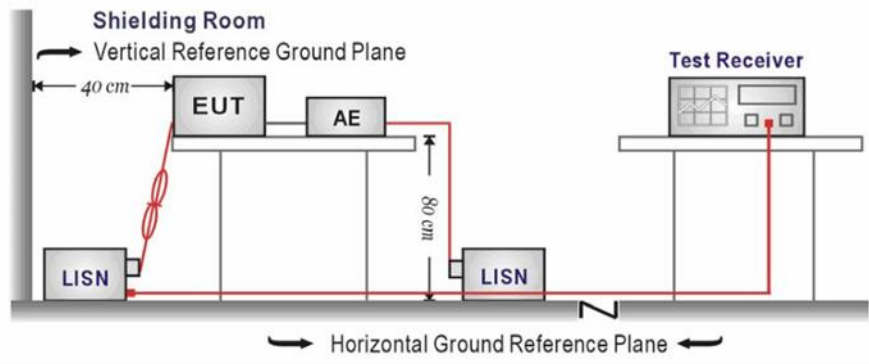

TEST PROCEDURE

1. The EUT was setup according to ANSI C63.10:2013 requirements.
2. The EUT was placed on a platform of nominal size, 1 m by 1.5 m, raised 80 cm above the conducting ground plane. The vertical conducting plane was located 40 cm to the rear of the EUT. All other surfaces of EUT were at least 80 cm from any other grounded conducting surface.
3. The EUT and simulators are connected to the main power through a line impedances stabilization network (LISN). The LISN provides a 50 ohm /50uH coupling impedance for the measuring equipment.
4. The peripheral devices are also connected to the main power through a LISN. (Please refer to the block diagram of the test setup and photographs)
5. Each current-carrying conductor of the EUT power cord, except the ground (safety) conductor, was individually connected through a LISN to the input power source.
6. The excess length of the power cord between the EUT and the LISN receptacle were folded back and forth at the center of the lead to form a bundle not exceeding 40 cm in length.
7. Conducted Emissions were investigated over the frequency range from 0.15MHz to 30MHz using a receiver bandwidth of 9 kHz.
8. During the above scans, the emissions were maximized by cable manipulation.

TEST MODE:

Please refer to the clause 3.3

TEST RESULTS

Passed Not Applicable

Note:

- 1) Transd=Cable lose+ Pulse Limiter Factor + Artificial Mains Factor
- 2) Margin= Limit -Level

Test Line:

L

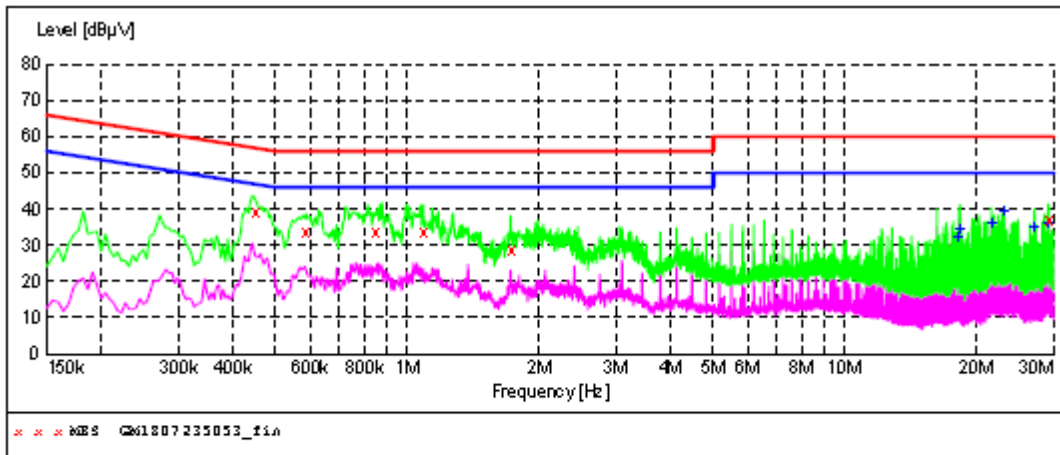

MEASUREMENT RESULT: "GM1807235053_fir"

7/23/2018 5:31PM

Frequency MHz	Level dBµV	Transd dB	Limit dBµV	Margin dB	Detector	Line	PE
0.451500	39.10	9.9	57	17.7	QP	L1	GND
0.586500	33.80	10.0	56	22.2	QP	L1	GND
0.843000	33.90	10.0	56	22.1	QP	L1	GND
1.086000	33.70	10.1	56	22.3	QP	L1	GND
1.725000	28.50	10.1	56	27.5	QP	L1	GND
29.233500	37.20	10.9	60	22.8	QP	L1	GND

MEASUREMENT RESULT: "GM1807235053_fir2"

7/23/2018 5:31PM

Frequency MHz	Level dBµV	Transd dB	Limit dBµV	Margin dB	Detector	Line	PE
18.244500	32.80	10.6	50	17.2	AV	L1	GND
18.303000	34.60	10.6	50	15.4	AV	L1	GND
21.664500	36.70	10.7	50	13.3	AV	L1	GND
23.127000	39.80	10.7	50	10.2	AV	L1	GND
27.159000	35.40	10.8	50	14.6	AV	L1	GND
29.233500	36.30	10.9	50	13.7	AV	L1	GND

Test Line:

N

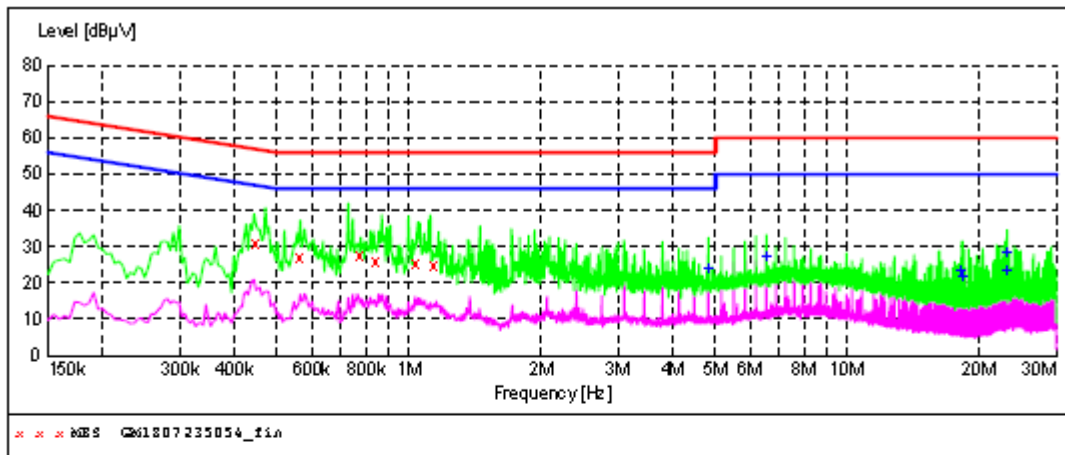

MEASUREMENT RESULT: "GM1807235054_fir"

7/23/2018 5:34PM

Frequency MHz	Level dBµV	Transd dB	Limit dBµV	Margin dB	Detector	Line	PE
0.447000	31.10	9.9	57	25.8	QP	N	GND
0.564000	27.10	10.0	56	28.9	QP	N	GND
0.766500	27.40	10.0	56	28.6	QP	N	GND
0.838500	26.20	10.0	56	29.8	QP	N	GND
1.032000	25.20	10.1	56	30.8	QP	N	GND
1.140000	25.00	10.1	56	31.0	QP	N	GND

MEASUREMENT RESULT: "GM1807235054_fir2"

7/23/2018 5:34PM

Frequency MHz	Level dBµV	Transd dB	Limit dBµV	Margin dB	Detector	Line	PE
4.812000	24.20	10.2	46	21.8	AV	N	GND
6.531000	27.70	10.2	50	22.3	AV	N	GND
18.240000	23.60	10.6	50	26.4	AV	N	GND
18.303000	22.20	10.6	50	27.8	AV	N	GND
23.068500	24.00	10.7	50	26.0	AV	N	GND
23.127000	28.50	10.7	50	21.5	AV	N	GND

5.3. Conducted Peak Output Power

LIMIT

FCC CFR Title 47 Part 15 Subpart C Section 15.247 (b)(3): **30dBm**:

TEST CONFIGURATION

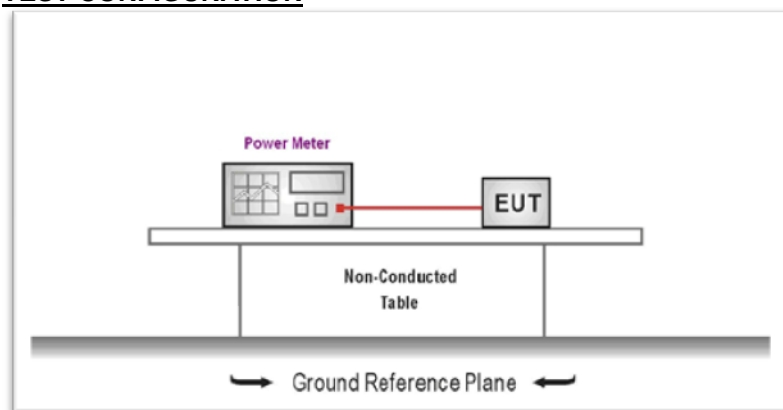

TEST PROCEDURE

1. The EUT was tested according to ANSI C63.10: 2013 and KDB 558074 D01 for compliance to FCC 47 CFR 15.247 requirements.
2. The maximum peak conducted output power may be measured using a broadband peak RF power meter.
3. The power meter shall have a video bandwidth that is greater than or equal to the DTS bandwidth and shall utilize a fast-responding diode detector
4. Record the measurement data.

TEST MODE:

Please refer to the clause 3.3

TEST RESULTS

Passed Not Applicable

Type	Channel	Output power (dBm)		Limit (dBm)	Result
		Antenna 1	Antenna 2		
802.11b	01	16.71	16.70	≤30.00	Pass
	06	16.85	16.69		
	11	16.83	16.61		
802.11g	01	15.96	15.32	≤30.00	Pass
	06	15.94	15.48		
	11	15.70	15.50		

MIMO

Type	Channel	Output power (dBm)		Total Power (dBm)	Limit (dBm)	Result
		Antenna 1	Antenna 2			
802.11n(HT20)	01	14.17	14.48	17.36	≤30.00	Pass
	06	14.12	14.62	17.37		
	11	14.45	14.67	17.61		
802.11n(HT40)	03	13.67	13.46	16.61	≤30.00	Pass
	06	13.55	13.53	16.56		
	09	13.44	13.57	16.51		

5.4. Power Spectral Density

LIMIT

FCC CFR Title 47 Part 15 Subpart C Section 15.247 (e):For digitally modulated systems, the power spectral density conducted from the intentional radiator to the antenna shall not be greater than 8 dBm in any 3 kHz band during any time interval of continuous transmission.

TEST CONFIGURATION

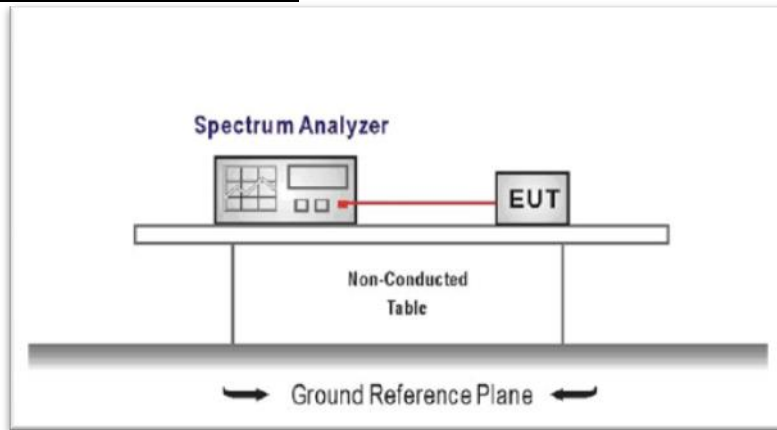

TEST PROCEDURE

1. Connect the antenna port(s) to the spectrum analyzer input,
2. Configure the spectrum analyzer as shown below:
Center frequency=DTS channel center frequency
Span =1.5 times the DTS bandwidth
 $RBW = 3 \text{ kHz} \leq RBW \leq 100 \text{ kHz}$, $VBW \geq 3 \times RBW$
Sweep time = auto couple
Detector = peak
Trace mode = max hold
3. Place the radio in continuous transmit mode, allow the trace to stabilize, view the transmitter wave form on the spectrum analyzer.
4. Use the peak marker function to determine the maximum amplitude level within the RBW.
5. If measured value exceeds limit, reduce RBW (no less than 3 kHz) and repeat.

TEST MODE:

Please refer to the clause 3.3

TEST RESULTS

Passed Not Applicable

Type	Channel	Power Spectral Density (dBm/30KHz)		Limit (dBm/3KHz)	Result
		Antenna 1	Antenna 2		
802.11b	01	-0.36	-0.58	≤8.00	Pass
	06	-0.65	-1.16		
	11	-0.13	-1.22		
802.11g	01	-8.08	-8.69	≤8.00	Pass
	06	-8.03	-8.55		
	11	-8.11	-8.50		

MIMO

Type	Channel	Power Spectral Density (dBm/30KHz)		Total Power Spectral Density (dBm/30KHz)	Limit (dBm/3KHz)	Result
		Antenna 1	Antenna 2			
802.11n(HT20)	01	-10.62	-10.12	-7.35	≤8.00	Pass
	06	-10.67	-10.05	-7.34		
	11	-10.20	-10.02	-7.10		
802.11n(HT40)	03	-14.10	-14.34	-11.21	≤8.00	Pass
	06	-14.18	-14.22	-11.19		
	09	-14.21	-14.19	-11.19		

Test plot as follows:

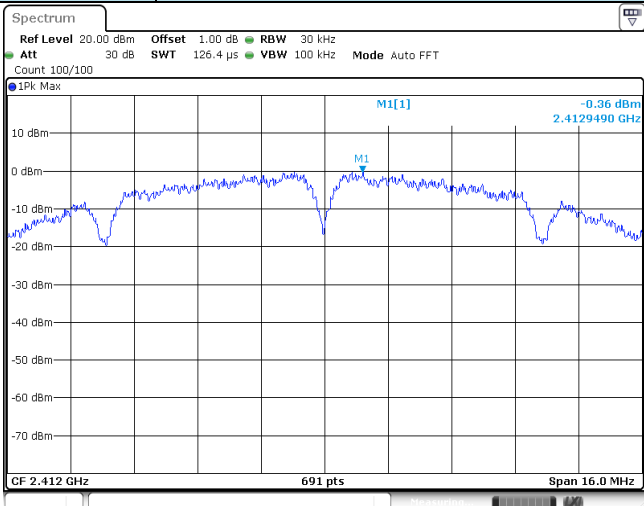
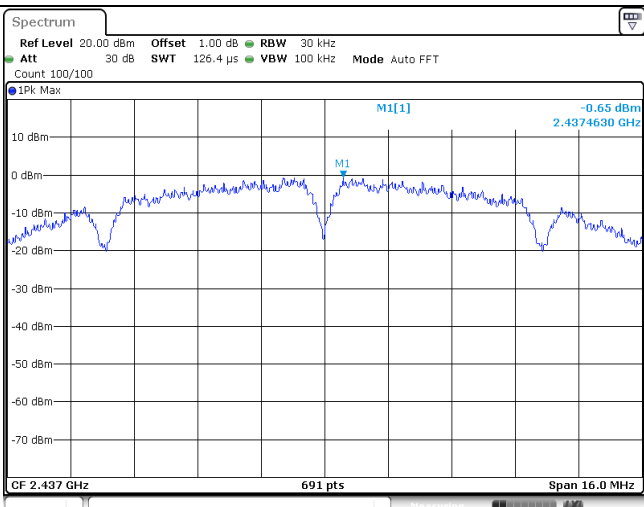
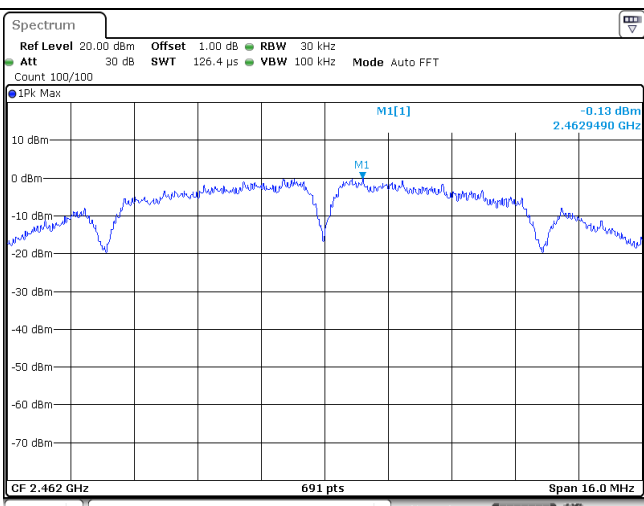
802.11 b		Antenna 1
CH01		
CH06		
CH11		

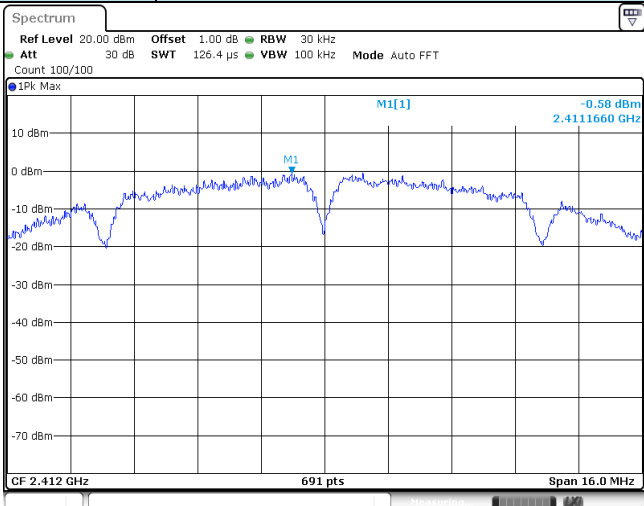
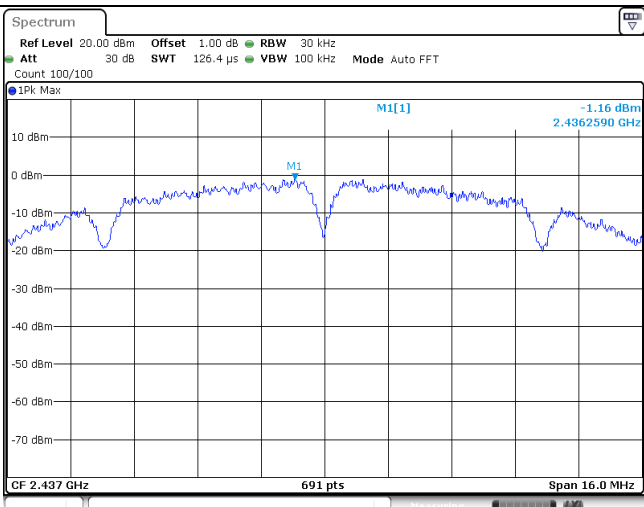
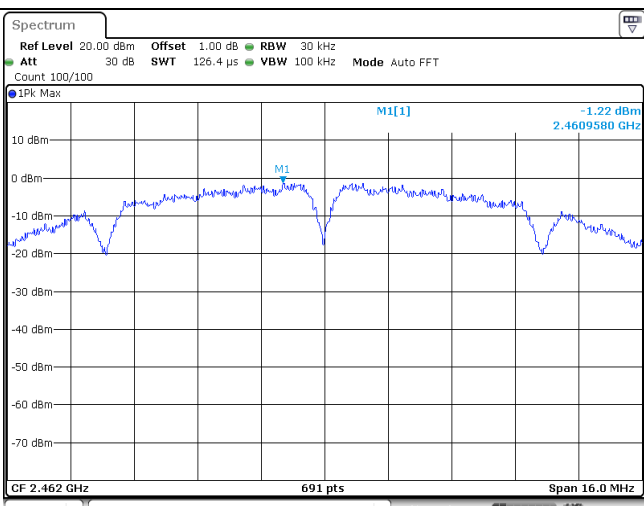
802.11 b		Antenna 2
CH01		
CH06		
CH11		

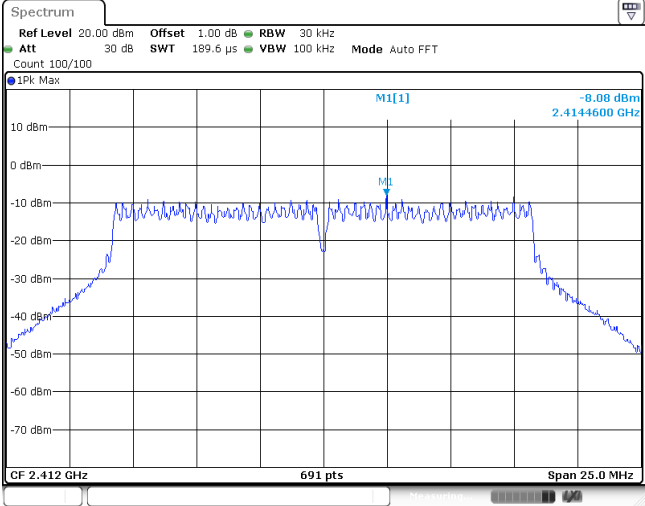
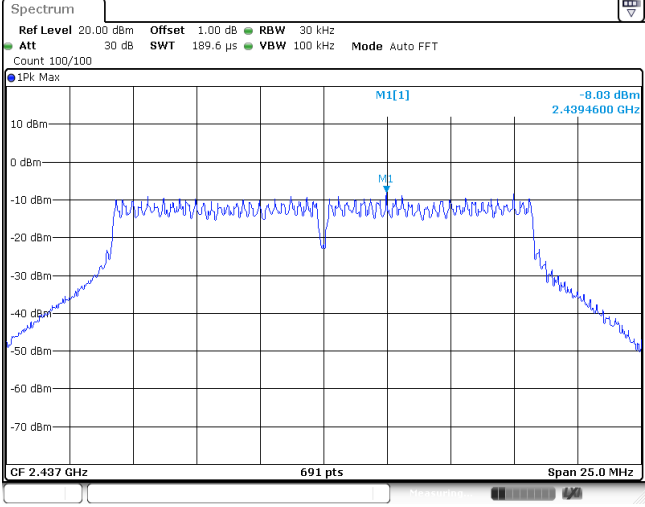
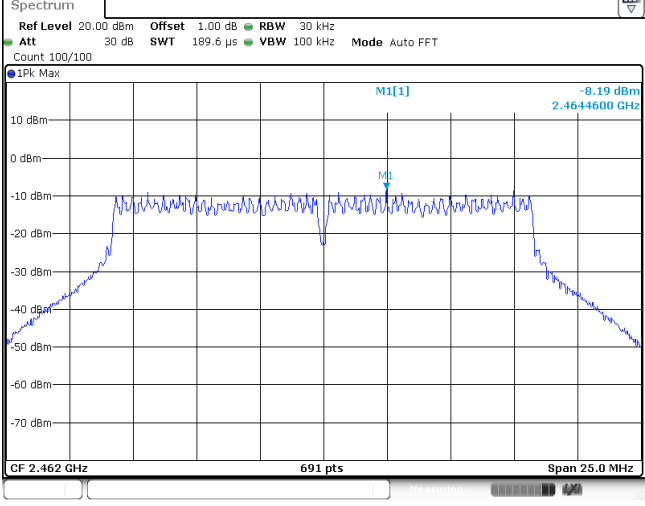
802.11 g		Antenna 1
CH01		
CH06		
CH11		

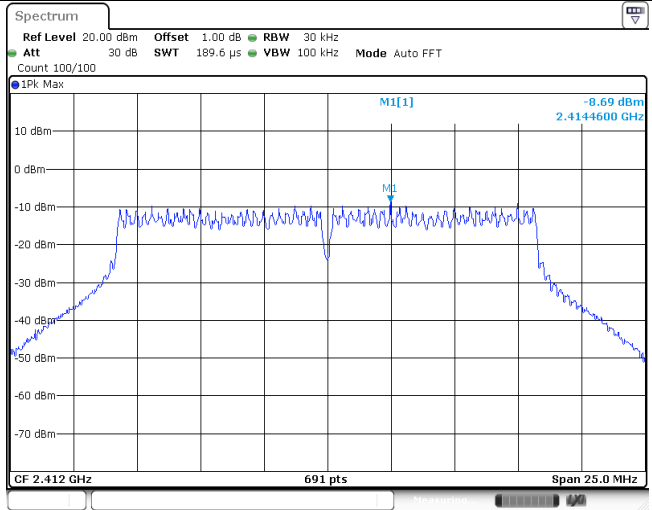
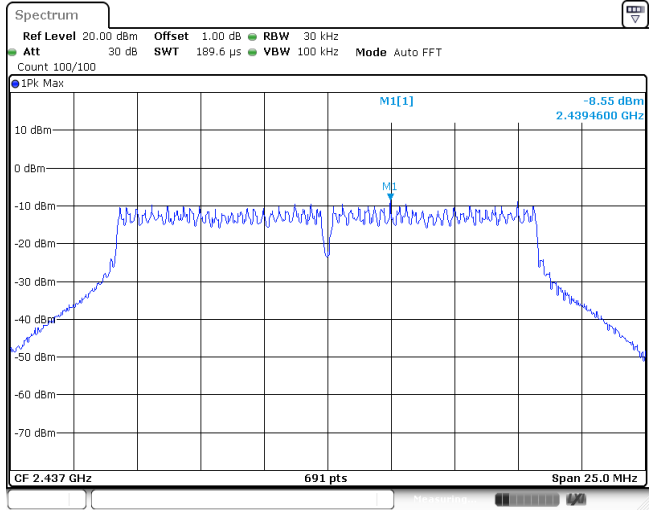
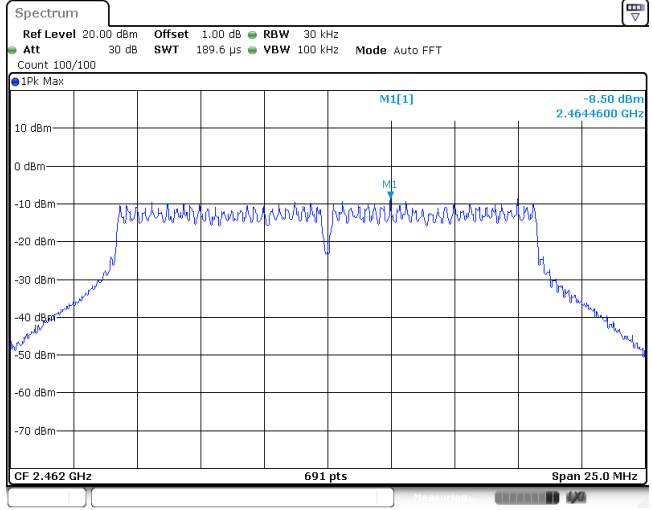
802.11 g		Antenna 2
CH01		
CH06		
CH11		

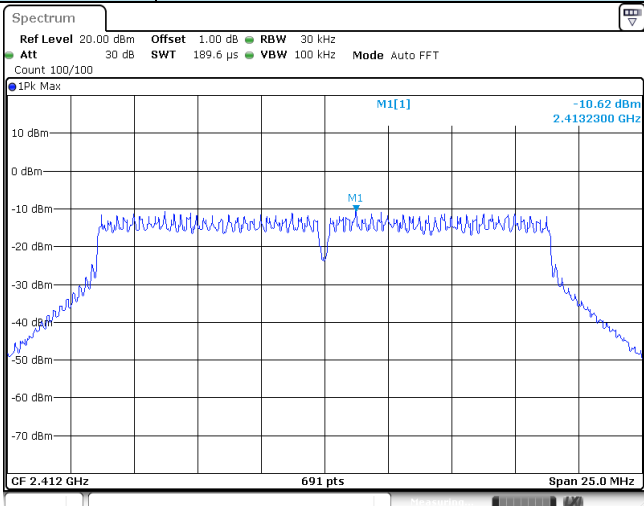
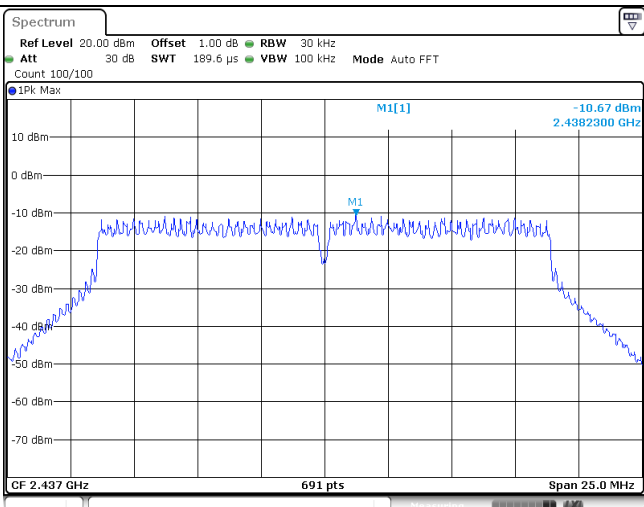
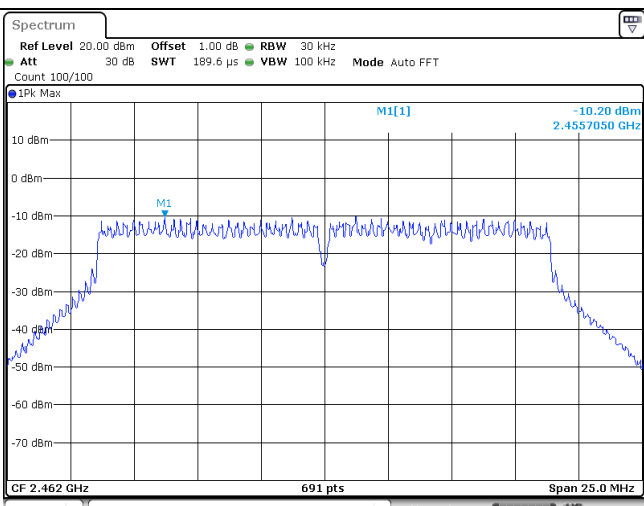
802.11 n(H20)		Antenna 1
CH01		
CH06		
CH11		

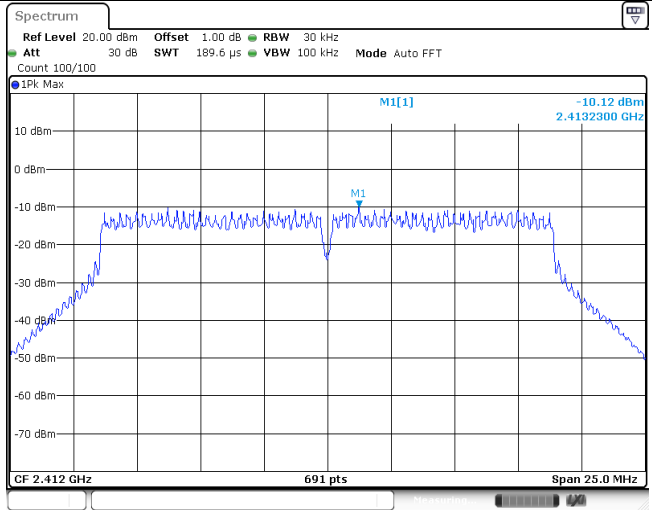
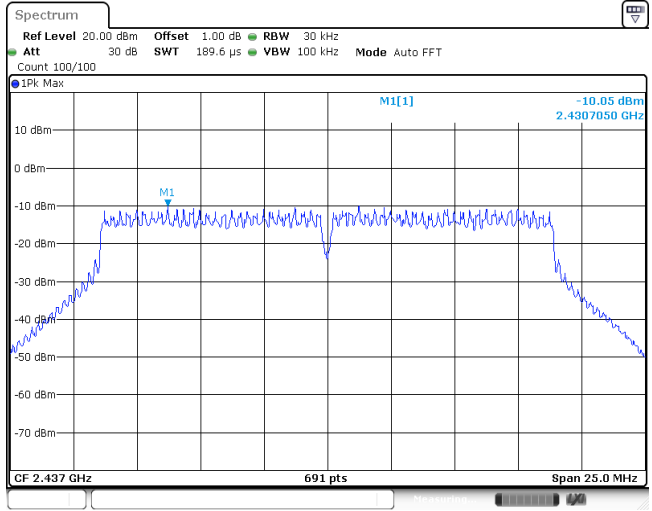
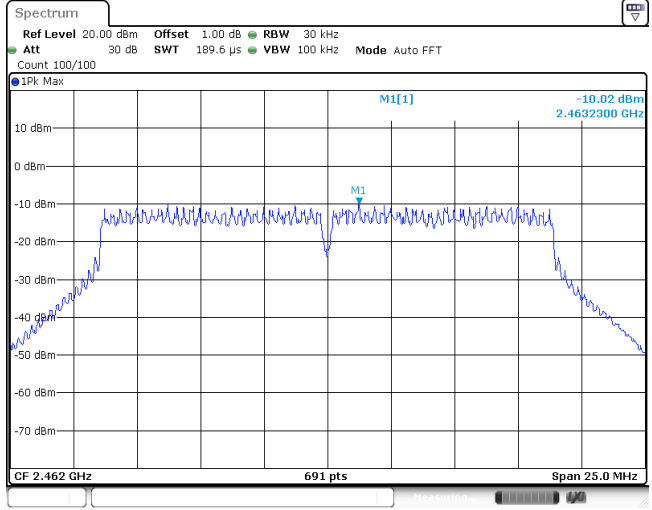
802.11 n(H20)		Antenna 2
CH01		
CH06		
CH11		

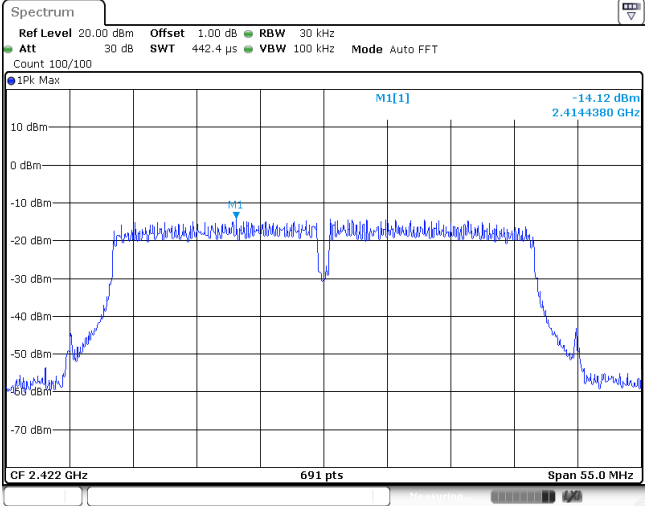
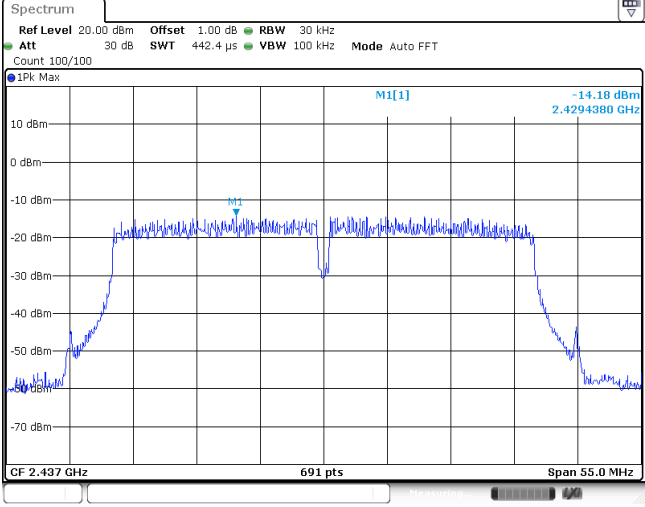
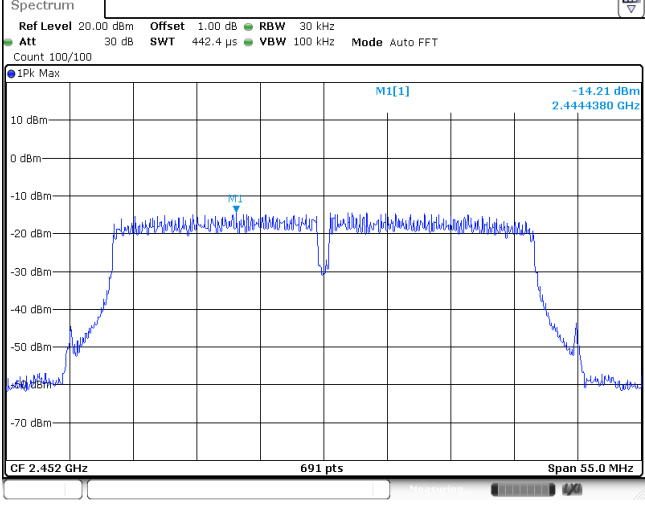
802.11 n(H40)		Antenna 1
CH03		
CH06		
CH09		

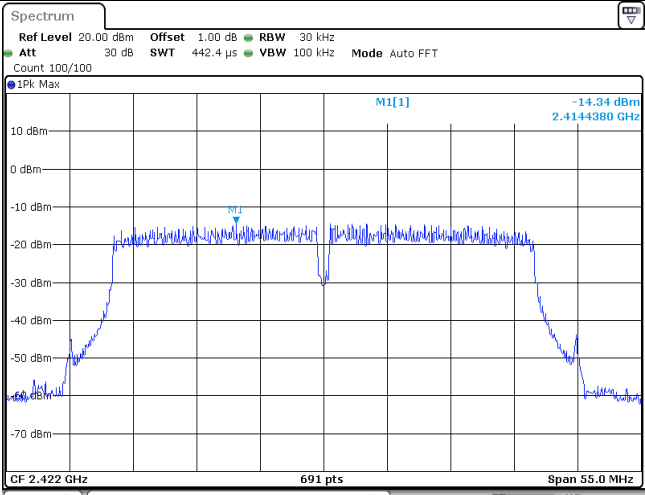
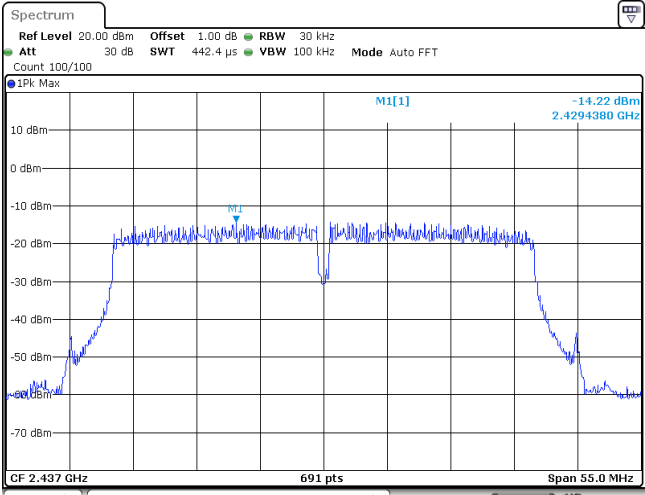
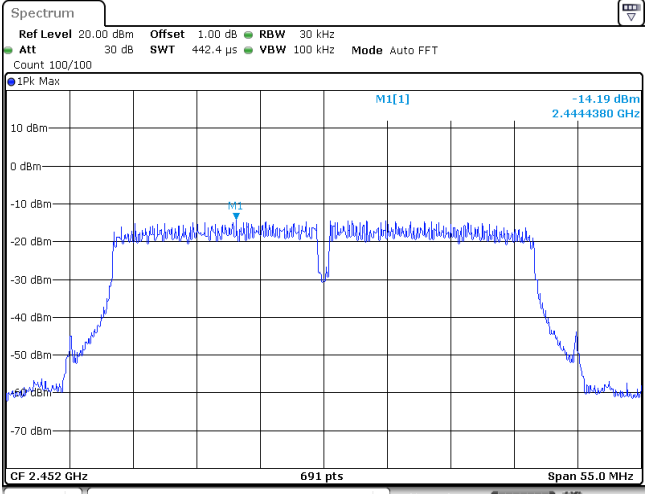
802.11 n(H40)		Antenna 2
CH03		
CH06		
CH09		

5.5. 6dB Bandwidth

LIMIT

FCC CFR Title 47 Part 15 Subpart C Section 15.247 (a)(2):For digital modulation systems, the minimum 6 dB bandwidth shall be at least 500 kHz.

TEST CONFIGURATION

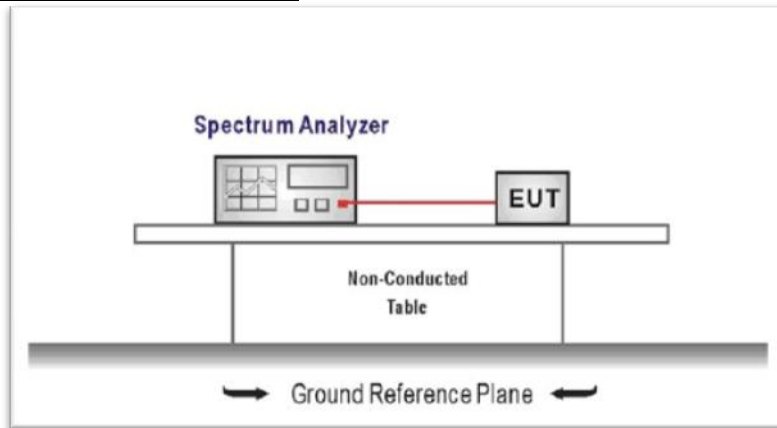

TEST PROCEDURE

1. Connect the antenna port(s) to the spectrum analyzer input.
2. Configure the spectrum analyzer as shown below (enter all losses between the transmitter output and the spectrum analyzer).
Center Frequency = DTS channel center frequency
Span = 2 x DTS bandwidth
RBW = 100 kHz, VBW \geq 3 x RBW
Sweep time = auto couple
Detector = Peak
Trace mode = max hold
3. Place the radio in continuous transmit mode, allow the trace to stabilize, view the transmitter wave form on the spectrum analyzer.
4. Measure the maximum width of the emission that is constrained by the frequencies associated with the two outermost amplitude points (upper and lower frequencies) that are attenuated by 6 dB relative to the maximum level measured in the fundamental emission, and record the pertinent measurements.

TEST MODE:

Please refer to the clause 3.3

TEST RESULTS

Passed Not Applicable

Type	Channel	6dB Bandwidth (MHz)		Limit (kHz)	Result
		Antenna 1	Antenna 2		
802.11b	01	9.63	10.11	≥500	Pass
	06	10.11	10.11		
	11	10.11	10.11		
802.11g	01	16.41	16.41	≥500	Pass
	06	16.41	16.41		
	11	16.41	16.41		
802.11n(HT20)	01	17.64	17.64	≥500	Pass
	06	17.64	17.64		
	11	17.64	17.64		
802.11n(HT40)	03	35.82	35.70	≥500	Pass
	06	35.82	35.82		
	09	35.82	35.82		

Test plot as follows:

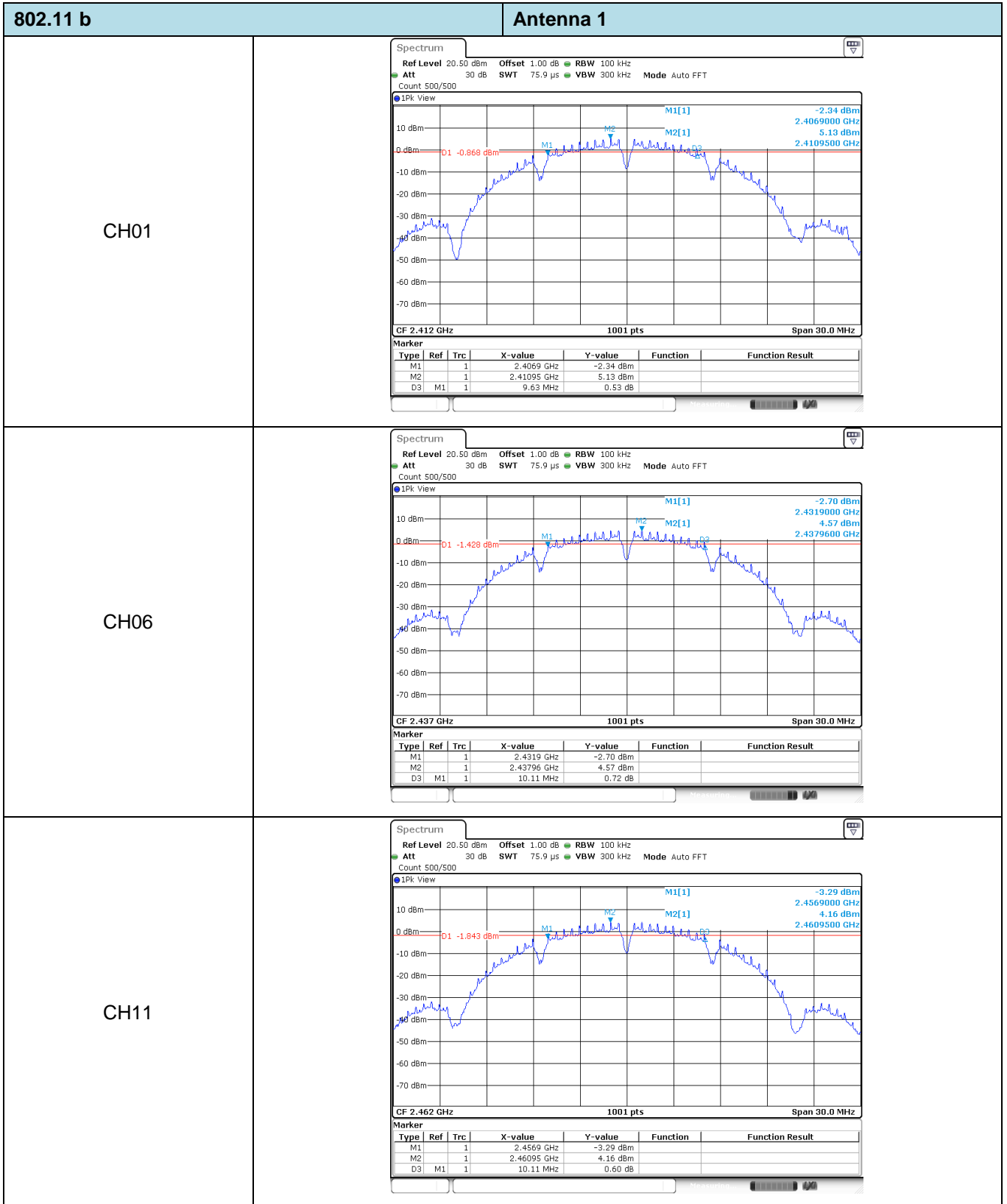

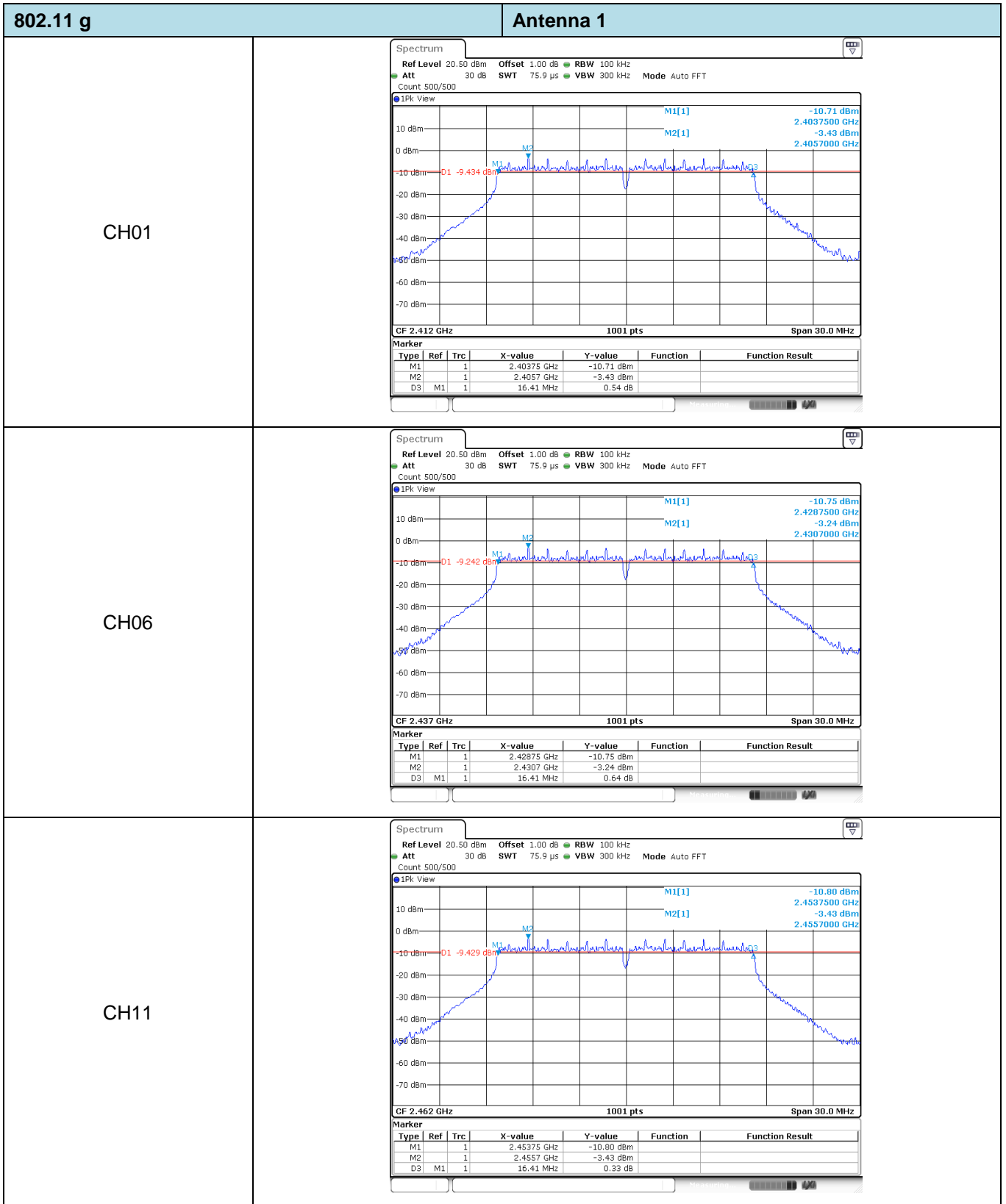

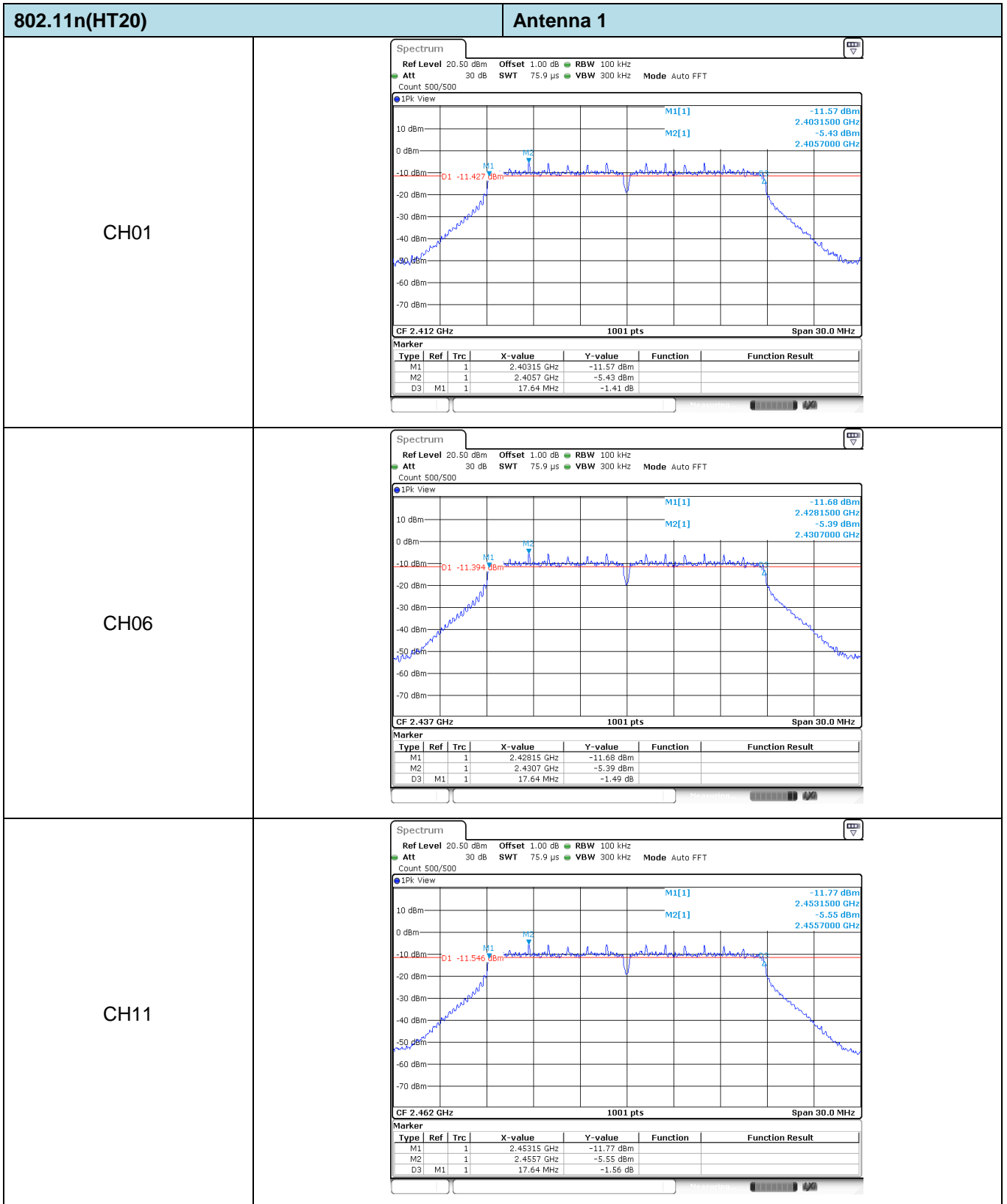

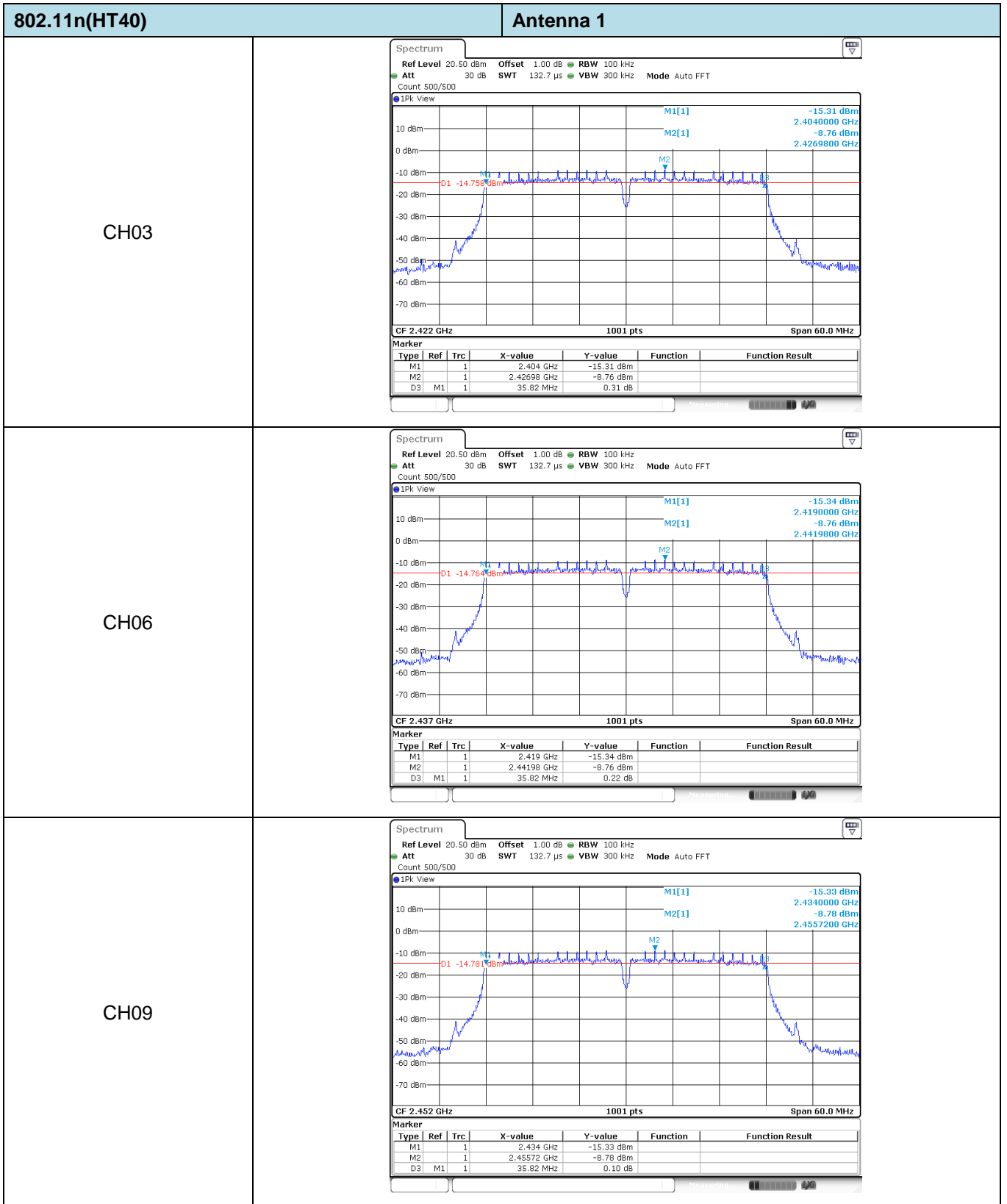

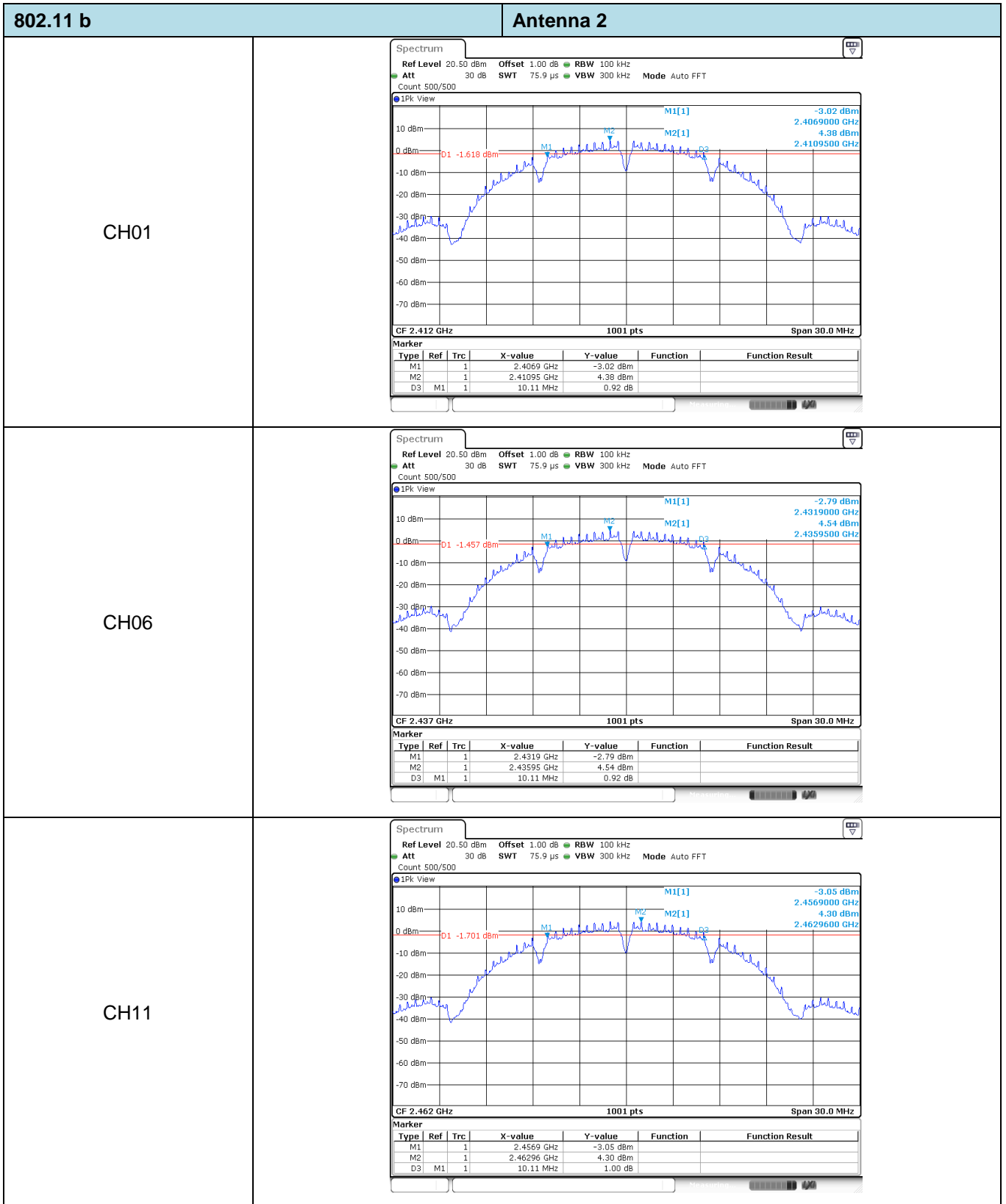

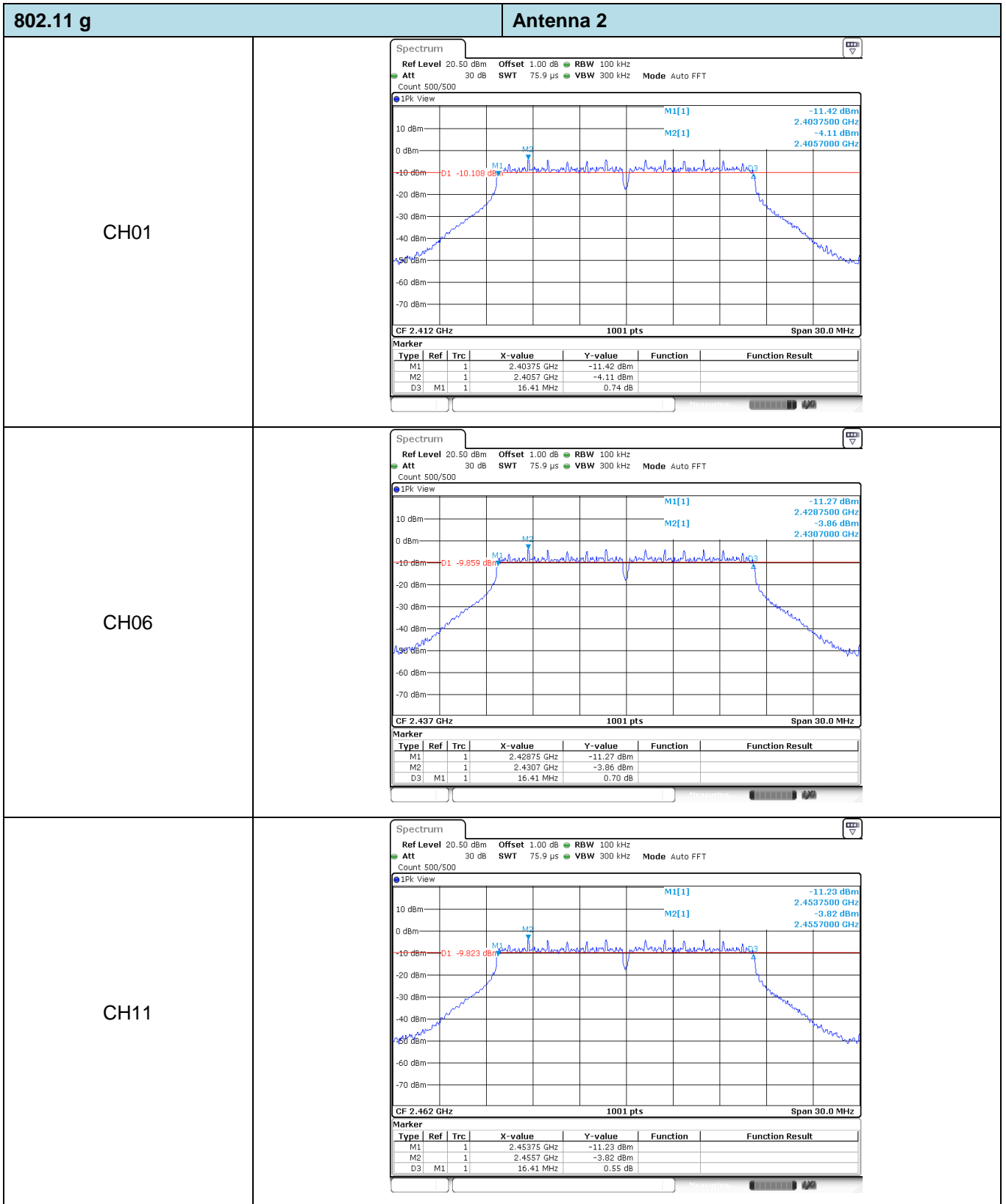

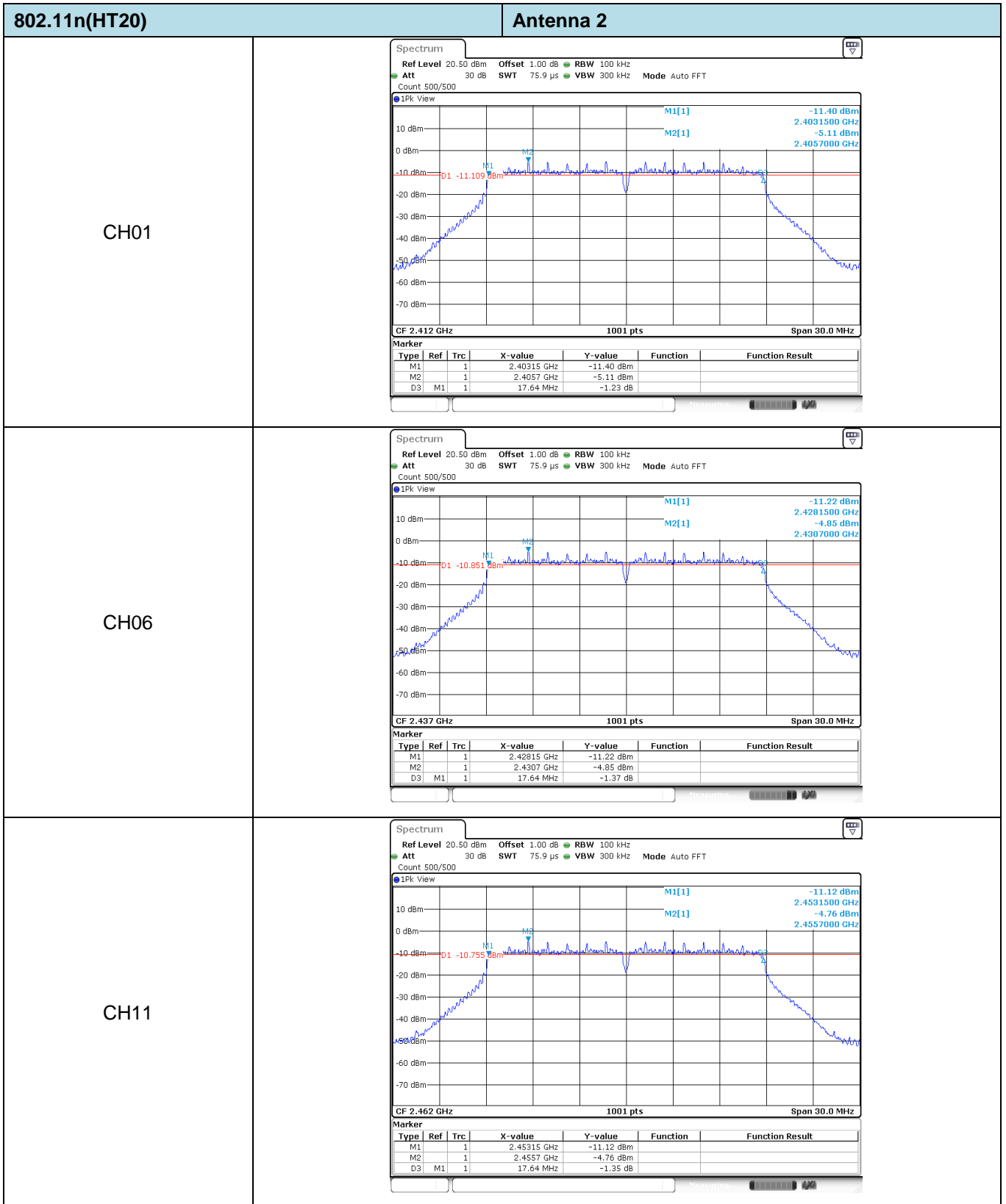

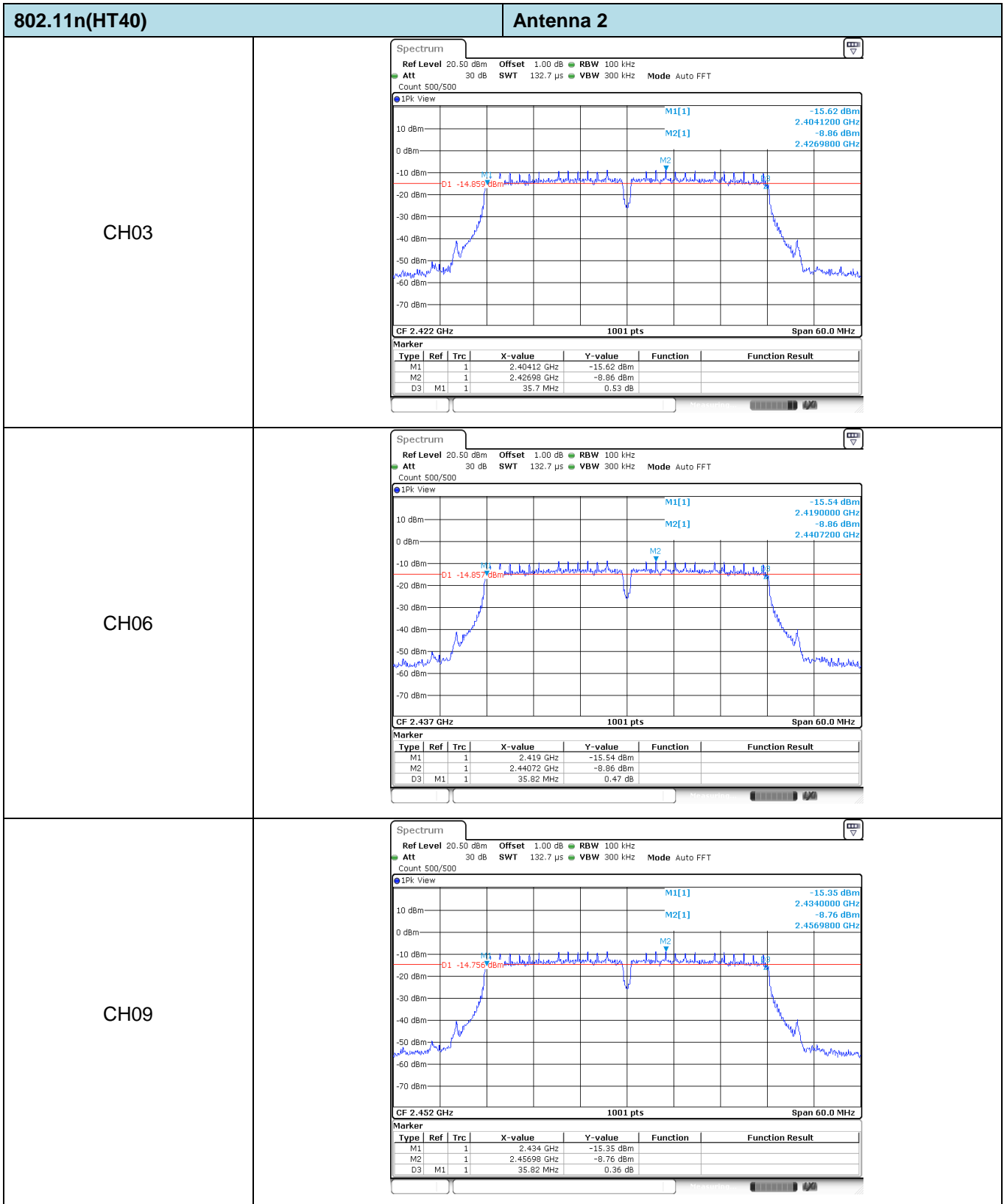

5.6. Restricted Band

LIMIT

FCC CFR Title 47 Part 15 Subpart C Section 15.247 (d):In any 100 kHz bandwidth outside the frequency band in which the spread spectrum or digitally modulated intentional radiator is operating, Radiated Emissions which fall in the restricted bands, as defined in §15.205(a), must also comply with the Radiated Emissions limits specified in §15.209(a) (see §15.205(c)).

TEST CONFIGURATION

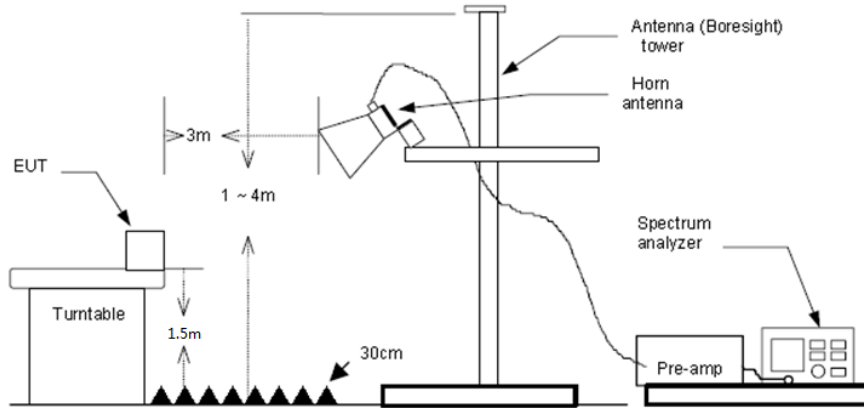

TEST PROCEDURE

- 1) The EUT was setup and tested according to ANSI C63.10:2013 for compliance to FCC 47CFR 15.247 requirements.
- 2) The EUT is placed on a turn table which is 1.5 meter above ground. The turn table is rotated 360 degrees to determine the position of the maximum emission level.
- 3) The EUT was positioned such that the distance from antenna to the EUT was 3 meters.
- 4) The antenna is scanned from 1 meter to 4 meters to find out the maximum emission level. This is repeated for both horizontal and vertical polarization of the antenna. In order to find the maximum emission, all of the interface cables were manipulated according to ANSI C63.10:2013 on radiated measurement.
- 5) The receiver set as follow:
 RBW=1MHz, VBW=3MHz PEAK detector for Peak value.
 RBW=1MHz, VBW=3MHz RMS detector for Average value.

TEST MODE:

Please refer to the clause 3.3

TEST RESULTS

Passed Not Applicable

Note:

- 1) Final level= Read level + Antenna Factor+ Cable Loss- Preamp Factor

802.11b					CH01				
Frequency (MHz)	Read Level (dBuV)	Antenna Factor (dB/m)	Cable Loss (dB)	Preamp Factor (dB)	Level (dBuV/m)	Limit Line (dBuV/m)	Over Limit (dB)	Polarization	Test value
2310.00	13.51	28.05	6.62	0.00	48.18	74.00	-25.82	Vertical	Peak
2390.00	14.42	27.65	6.75	0.00	48.82	74.00	-25.18	Vertical	Peak
2310.00	13.35	28.05	6.62	0.00	48.02	74.00	-25.98	Horizontal	Peak
2390.00	13.02	27.65	6.75	0.00	47.42	74.00	-26.58	Horizontal	Peak
2310.00	11.04	28.05	6.62	0.00	45.71	54.00	-8.29	Vertical	Average
2390.00	11.13	27.65	6.75	0.00	45.53	54.00	-8.47	Vertical	Average
2310.00	10.99	28.05	6.62	0.00	45.66	54.00	-8.34	Horizontal	Average
2390.00	10.60	27.65	6.75	0.00	45.00	54.00	-9.00	Horizontal	Average

802.11b					CH11				
Frequency (MHz)	Read Level (dBuV)	Antenna Factor (dB/m)	Cable Loss (dB)	Preamp Factor (dB)	Level (dBuV/m)	Limit Line (dBuV/m)	Over Limit (dB)	Polarization	Test value
2483.49	14.17	27.27	6.83	0.00	48.27	74.00	-25.73	Vertical	Peak
2500.00	14.60	27.20	6.84	0.00	48.64	74.00	-25.36	Vertical	Peak
2483.49	13.43	27.26	6.83	0.00	47.52	74.00	-26.48	Horizontal	Peak
2500.00	16.99	27.26	6.83	0.00	51.08	74.00	-22.92	Horizontal	Peak
2483.49	11.41	27.26	6.83	0.00	45.50	54.00	-8.50	Vertical	Average
2500.00	10.93	27.20	6.84	0.00	44.97	54.00	-9.03	Vertical	Average
2483.49	10.69	27.26	6.83	0.00	44.78	54.00	-9.22	Horizontal	Average
2500.00	10.61	27.20	6.84	0.00	44.65	54.00	-9.35	Horizontal	Average

802.11g					CH01				
Frequency (MHz)	Read Level (dBuV)	Antenna Factor (dB/m)	Cable Loss (dB)	Preamp Factor (dB)	Level (dBuV/m)	Limit Line (dBuV/m)	Over Limit (dB)	Polarization	Test value
2310.00	13.59	28.05	6.62	0.00	48.26	74.00	-25.74	Vertical	Peak
2390.00	14.54	27.65	6.75	0.00	48.94	74.00	-25.06	Vertical	Peak
2310.00	13.64	28.05	6.62	0.00	48.31	74.00	-25.69	Horizontal	Peak
2390.00	13.81	27.65	6.75	0.00	48.21	74.00	-25.79	Horizontal	Peak
2310.00	11.07	28.05	6.62	0.00	45.74	54.00	-8.26	Vertical	Average
2390.00	11.88	27.65	6.75	0.00	46.28	54.00	-7.72	Vertical	Average
2310.00	10.99	28.05	6.62	0.00	45.66	54.00	-8.34	Horizontal	Average
2390.00	10.60	27.65	6.75	0.00	45.00	54.00	-9.00	Horizontal	Average

802.11g					CH11				
Frequency (MHz)	Read Level (dBuV)	Antenna Factor (dB/m)	Cable Loss (dB)	Preamp Factor (dB)	Level (dBuV/m)	Limit Line (dBuV/m)	Over Limit (dB)	Polarization	Test value
2483.49	13.03	27.26	6.83	0.00	47.12	74.00	-26.88	Vertical	Peak
2500.00	12.72	27.20	6.84	0.00	46.76	74.00	-27.24	Vertical	Peak
2483.49	13.03	27.26	6.83	0.00	47.12	74.00	-26.88	Horizontal	Peak
2500.00	12.72	27.20	6.84	0.00	46.76	74.00	-27.24	Horizontal	Peak
2483.49	11.50	27.26	6.83	0.00	45.59	54.00	-8.41	Vertical	Average
2500.00	10.71	27.20	6.84	0.00	44.75	54.00	-9.25	Vertical	Average
2483.49	10.57	27.26	6.83	0.00	44.66	54.00	-9.34	Horizontal	Average
2500.00	10.57	27.20	6.84	0.00	44.61	54.00	-9.39	Horizontal	Average

802.11n(HT20)					CH01				
Frequency (MHz)	Read Level (dBuV)	Antenna Factor (dB/m)	Cable Loss (dB)	Preamp Factor (dB)	Level (dBuV/m)	Limit Line (dBuV/m)	Over Limit (dB)	Polarization	Test value
2310.00	12.04	28.05	6.62	0.00	46.71	74.00	-27.29	Vertical	Peak
2390.00	14.12	27.65	6.75	0.00	48.52	74.00	-25.48	Vertical	Peak
2310.00	14.42	28.05	6.62	0.00	49.09	74.00	-24.91	Horizontal	Peak
2390.00	13.94	27.65	6.75	0.00	48.34	74.00	-25.66	Horizontal	Peak
2310.00	11.05	28.05	6.62	0.00	45.72	54.00	-8.28	Vertical	Average
2390.00	11.99	27.65	6.75	0.00	46.39	54.00	-7.61	Vertical	Average
2310.00	11.01	28.05	6.62	0.00	45.68	54.00	-8.32	Horizontal	Average
2390.00	10.76	27.65	6.75	0.00	45.16	54.00	-8.84	Horizontal	Average

802.11n(HT20)					CH11				
Frequency (MHz)	Read Level (dBuV)	Antenna Factor (dB/m)	Cable Loss (dB)	Preamp Factor (dB)	Level (dBuV/m)	Limit Line (dBuV/m)	Over Limit (dB)	Polarization	Test value
2483.49	14.66	27.26	6.83	0.00	48.75	74.00	-25.25	Vertical	Peak
2500.00	14.45	27.20	6.84	0.00	48.49	74.00	-25.51	Vertical	Peak
2483.49	14.27	27.26	6.83	0.00	48.36	74.00	-25.64	Horizontal	Peak
2500.00	14.15	27.20	6.84	0.00	48.19	74.00	-25.81	Horizontal	Peak
2483.49	11.91	27.26	6.83	0.00	46.00	54.00	-8.00	Vertical	Average
2500.00	10.84	27.20	6.84	0.00	44.88	54.00	-9.12	Vertical	Average
2483.49	10.70	27.26	6.83	0.00	44.79	54.00	-9.21	Horizontal	Average
2500.00	10.58	27.20	6.84	0.00	44.62	54.00	-9.38	Horizontal	Average

802.11n(HT40)					CH03				
Frequency (MHz)	Read Level (dBuV)	Antenna Factor (dB/m)	Cable Loss (dB)	Preamplifier Factor (dB)	Level (dBuV/m)	Limit Line (dBuV/m)	Over Limit (dB)	Polarization	Test value
2310.00	14.63	28.05	6.62	0.00	49.30	74.00	-24.70	Vertical	Peak
2390.00	14.87	27.65	6.75	0.00	49.27	74.00	-24.73	Vertical	Peak
2310.00	14.63	28.05	6.62	0.00	49.30	74.00	-24.70	Horizontal	Peak
2390.00	13.47	27.65	6.75	0.00	47.87	74.00	-26.13	Horizontal	Peak
2310.00	11.06	28.05	6.62	0.00	45.73	54.00	-8.27	Vertical	Average
2390.00	12.19	27.65	6.75	0.00	46.59	54.00	-7.41	Vertical	Average
2310.00	11.04	28.05	6.62	0.00	45.71	54.00	-8.29	Horizontal	Average
2390.00	10.76	27.65	6.75	0.00	45.16	54.00	-8.84	Horizontal	Average

802.11n(HT40)					CH09				
Frequency (MHz)	Read Level (dBuV)	Antenna Factor (dB/m)	Cable Loss (dB)	Preamplifier Factor (dB)	Level (dBuV/m)	Limit Line (dBuV/m)	Over Limit (dB)	Polarization	Test value
2483.49	15.35	27.26	6.83	0.00	49.44	74.00	-24.56	Vertical	Peak
2500.00	14.59	27.20	6.84	0.00	48.63	74.00	-25.37	Vertical	Peak
2483.49	14.18	27.26	6.83	0.00	48.27	74.00	-25.73	Horizontal	Peak
2500.00	13.21	27.20	6.84	0.00	47.25	74.00	-26.75	Horizontal	Peak
2483.49	12.34	27.26	6.83	0.00	46.43	54.00	-7.57	Vertical	Average
2500.00	11.00	27.20	6.84	0.00	45.04	54.00	-8.96	Vertical	Average
2483.49	11.09	27.26	6.83	0.00	45.18	54.00	-8.82	Horizontal	Average
2500.00	10.70	27.20	6.84	0.00	44.74	54.00	-9.26	Horizontal	Average

5.7. Band Edge and Spurious Emissions (Conducted)

LIMIT

FCC CFR Title 47 Part 15 Subpart C Section 15.247 (d): In any 100 kHz bandwidth outside the frequency band in which the spread spectrum intentional radiator is operating, the radio frequency power that is produced by the intentional radiator shall be at least 20 dB below that in the 100 kHz bandwidth within the band that contains the highest level of the desired power, based on either an RF conducted or a radiated measurement.

TEST CONFIGURATION

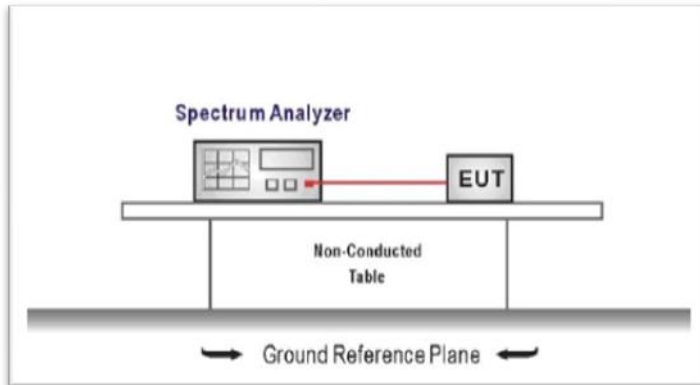

TEST PROCEDURE

1. Connect the antenna port(s) to the spectrum analyzer input.
2. Establish a reference level by using the following procedure
Center frequency=DTS channel center frequency
The span = 1.5 times the DTS bandwidth.
RBW = 100 kHz, VBW $\geq 3 \times$ RBW
Detector = peak, Sweep time = auto couple, Trace mode = max hold
Allow trace to fully stabilize
Use the peak marker function to determine the maximum PSD level



Note: the channel found to contain the maximum PSD level can be used to establish the reference level.
3. Emission level measurement
Set the center frequency and span to encompass frequency range to be measured
RBW = 100 kHz, VBW $\geq 3 \times$ RBW
Detector = peak, Sweep time = auto couple, Trace mode = max hold
Allow trace to fully stabilize
Use the peak marker function to determine the maximum amplitude level.
4. Place the radio in continuous transmit mode, allow the trace to stabilize, view the transmitter waveform on the spectrum analyzer.
5. Ensure that the amplitude of all unwanted emission outside of the authorized frequency band excluding restricted frequency bands) are attenuated by at least the minimum requirements specified (at least 20 dB relative to the maximum in-band peak PSD level in 100 kHz). Report the three highest emission relative to the limit.

TEST MODE:

Please refer to the clause 3.3

TEST RESULTS

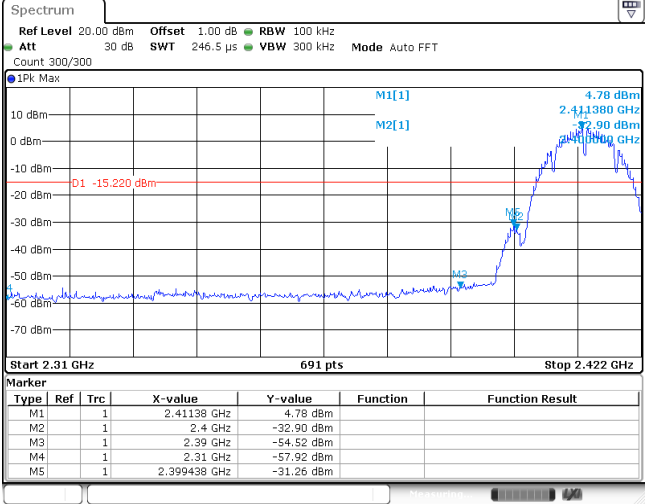
Passed Not Applicable

Test Item:	Bandedge	802.11 b	Antenna 1																																										
CH01	 <p>Spectrum Ref Level 20.00 dBm Offset 1.00 dB RBW 100 kHz Att 30 dB SWT 246.5 μs VBW 300 kHz Mode Auto FFT Count 300/300</p> <p>1Pk Max</p> <p>10 dBm 0 dBm -10 dBm -20 dBm -30 dBm -40 dBm -50 dBm -60 dBm -70 dBm</p> <p>M1[1] 4.78 dBm 2.411380 GHz M2[1] -32.90 dBm 2.411380 GHz</p> <p>D1 -15.220 dBm</p> <p>Start 2.31 GHz 691 pts Stop 2.422 GHz</p> <table border="1"> <thead> <tr> <th>Type</th> <th>Ref</th> <th>Trc</th> <th>X-value</th> <th>Y-value</th> <th>Function</th> <th>Function Result</th> </tr> </thead> <tbody> <tr> <td>M1</td> <td>1</td> <td>1</td> <td>2.41138 GHz</td> <td>4.78 dBm</td> <td></td> <td></td> </tr> <tr> <td>M2</td> <td>1</td> <td>1</td> <td>2.4 GHz</td> <td>-32.90 dBm</td> <td></td> <td></td> </tr> <tr> <td>M3</td> <td>1</td> <td>1</td> <td>2.39 GHz</td> <td>-54.52 dBm</td> <td></td> <td></td> </tr> <tr> <td>M4</td> <td>1</td> <td>1</td> <td>2.31 GHz</td> <td>-57.92 dBm</td> <td></td> <td></td> </tr> <tr> <td>M5</td> <td>1</td> <td>1</td> <td>2.399438 GHz</td> <td>-31.26 dBm</td> <td></td> <td></td> </tr> </tbody> </table>			Type	Ref	Trc	X-value	Y-value	Function	Function Result	M1	1	1	2.41138 GHz	4.78 dBm			M2	1	1	2.4 GHz	-32.90 dBm			M3	1	1	2.39 GHz	-54.52 dBm			M4	1	1	2.31 GHz	-57.92 dBm			M5	1	1	2.399438 GHz	-31.26 dBm		
Type	Ref	Trc	X-value	Y-value	Function	Function Result																																							
M1	1	1	2.41138 GHz	4.78 dBm																																									
M2	1	1	2.4 GHz	-32.90 dBm																																									
M3	1	1	2.39 GHz	-54.52 dBm																																									
M4	1	1	2.31 GHz	-57.92 dBm																																									
M5	1	1	2.399438 GHz	-31.26 dBm																																									
CH11	 <p>Spectrum Ref Level 20.00 dBm Offset 1.00 dB RBW 100 kHz Att 30 dB SWT 113.8 μs VBW 300 kHz Mode Auto FFT Count 300/300</p> <p>1Pk Max</p> <p>10 dBm 0 dBm -10 dBm -20 dBm -30 dBm -40 dBm -50 dBm -60 dBm -70 dBm</p> <p>M1[1] 4.69 dBm 2.4614820 GHz M2[1] -57.14 dBm 2.4835000 GHz</p> <p>D1 -15.310 dBm</p> <p>Start 2.452 GHz 691 pts Stop 2.5 GHz</p> <table border="1"> <thead> <tr> <th>Type</th> <th>Ref</th> <th>Trc</th> <th>X-value</th> <th>Y-value</th> <th>Function</th> <th>Function Result</th> </tr> </thead> <tbody> <tr> <td>M1</td> <td>1</td> <td>1</td> <td>2.461482 GHz</td> <td>4.69 dBm</td> <td></td> <td></td> </tr> <tr> <td>M2</td> <td>1</td> <td>1</td> <td>2.4835 GHz</td> <td>-57.14 dBm</td> <td></td> <td></td> </tr> <tr> <td>M3</td> <td>1</td> <td>1</td> <td>2.5 GHz</td> <td>-58.76 dBm</td> <td></td> <td></td> </tr> <tr> <td>M4</td> <td>1</td> <td>1</td> <td>2.4862957 GHz</td> <td>-54.67 dBm</td> <td></td> <td></td> </tr> </tbody> </table>			Type	Ref	Trc	X-value	Y-value	Function	Function Result	M1	1	1	2.461482 GHz	4.69 dBm			M2	1	1	2.4835 GHz	-57.14 dBm			M3	1	1	2.5 GHz	-58.76 dBm			M4	1	1	2.4862957 GHz	-54.67 dBm									
Type	Ref	Trc	X-value	Y-value	Function	Function Result																																							
M1	1	1	2.461482 GHz	4.69 dBm																																									
M2	1	1	2.4835 GHz	-57.14 dBm																																									
M3	1	1	2.5 GHz	-58.76 dBm																																									
M4	1	1	2.4862957 GHz	-54.67 dBm																																									

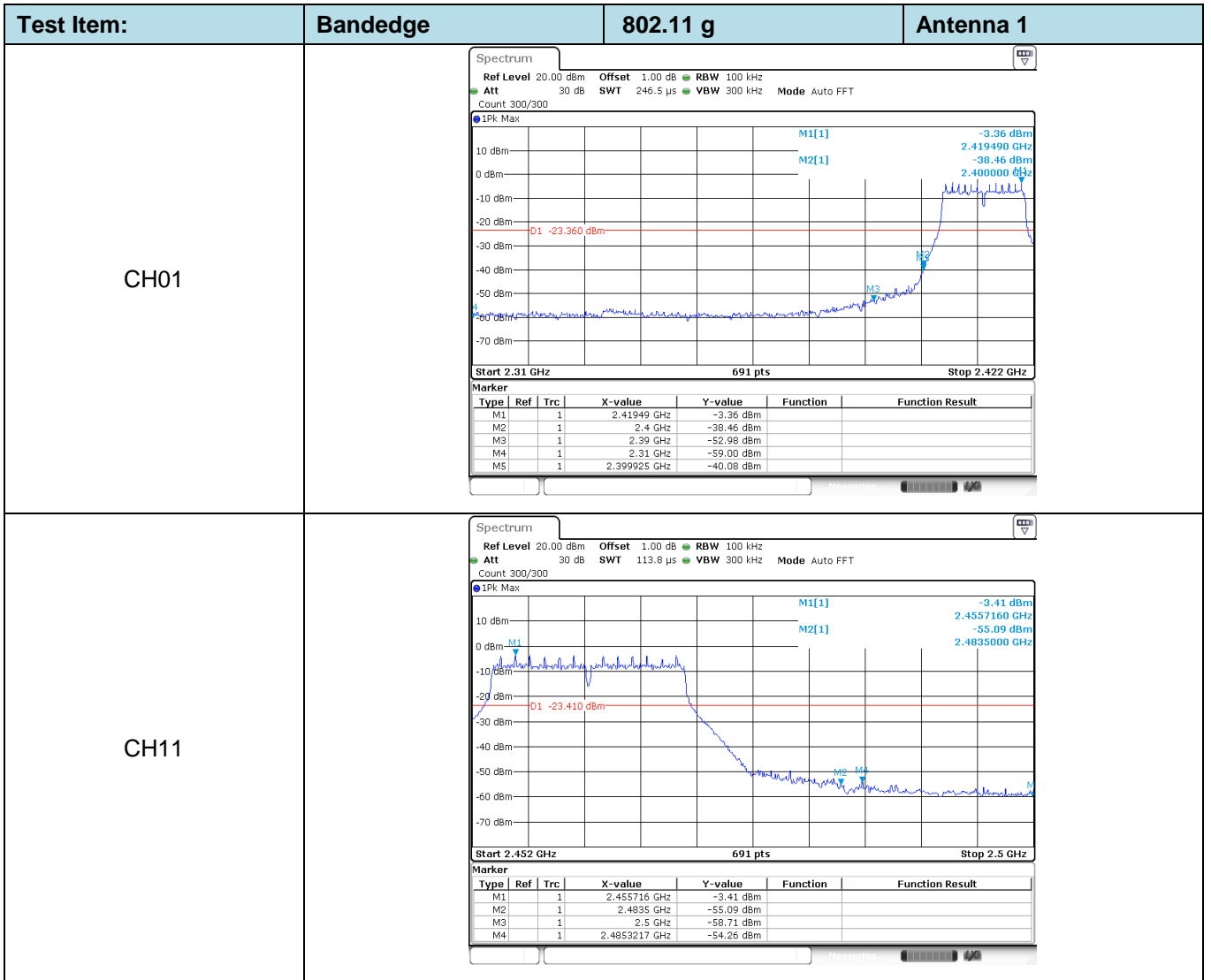

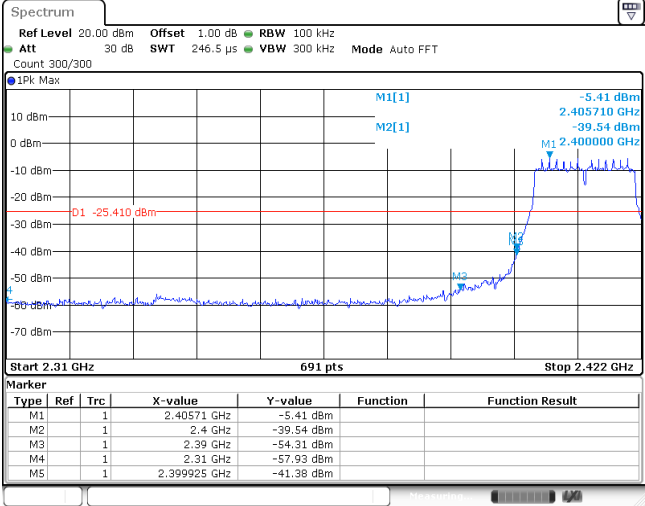
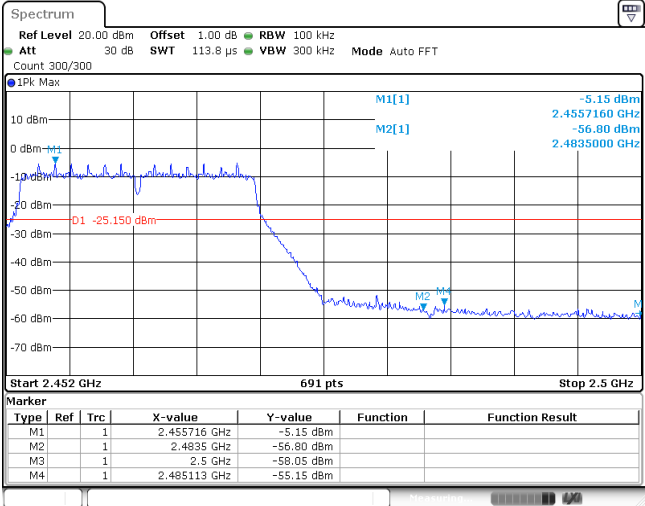
Test Item:	Bandedge	802.11 n(HT20)	Antenna 1																																										
CH01	 <p>Spectrum Ref Level 20.00 dBm Offset 1.00 dB RBW 100 kHz Att 30 dB SWT 246.5 μs VBW 300 kHz Mode Auto FFT Count 300/300</p> <p>1Pk Max</p> <p>10 dBm 0 dBm -10 dBm -20 dBm -30 dBm -40 dBm -50 dBm -60 dBm -70 dBm</p> <p>M1[1] -5.41 dBm 2.405710 GHz M2[1] -39.54 dBm 2.400000 GHz M1 2.400000 GHz</p> <p>D1 -25.410 dBm</p> <p>Start 2.31 GHz 691 pts Stop 2.422 GHz</p> <table border="1"> <thead> <tr> <th>Type</th> <th>Ref</th> <th>Trc</th> <th>X-value</th> <th>Y-value</th> <th>Function</th> <th>Function Result</th> </tr> </thead> <tbody> <tr> <td>M1</td> <td>1</td> <td></td> <td>2.40571 GHz</td> <td>-5.41 dBm</td> <td></td> <td></td> </tr> <tr> <td>M2</td> <td>1</td> <td></td> <td>2.4 GHz</td> <td>-39.54 dBm</td> <td></td> <td></td> </tr> <tr> <td>M3</td> <td>1</td> <td></td> <td>2.39 GHz</td> <td>-54.31 dBm</td> <td></td> <td></td> </tr> <tr> <td>M4</td> <td>1</td> <td></td> <td>2.31 GHz</td> <td>-57.93 dBm</td> <td></td> <td></td> </tr> <tr> <td>M5</td> <td>1</td> <td></td> <td>2.399925 GHz</td> <td>-41.38 dBm</td> <td></td> <td></td> </tr> </tbody> </table>			Type	Ref	Trc	X-value	Y-value	Function	Function Result	M1	1		2.40571 GHz	-5.41 dBm			M2	1		2.4 GHz	-39.54 dBm			M3	1		2.39 GHz	-54.31 dBm			M4	1		2.31 GHz	-57.93 dBm			M5	1		2.399925 GHz	-41.38 dBm		
Type	Ref	Trc	X-value	Y-value	Function	Function Result																																							
M1	1		2.40571 GHz	-5.41 dBm																																									
M2	1		2.4 GHz	-39.54 dBm																																									
M3	1		2.39 GHz	-54.31 dBm																																									
M4	1		2.31 GHz	-57.93 dBm																																									
M5	1		2.399925 GHz	-41.38 dBm																																									
CH11	 <p>Spectrum Ref Level 20.00 dBm Offset 1.00 dB RBW 100 kHz Att 30 dB SWT 113.8 μs VBW 300 kHz Mode Auto FFT Count 300/300</p> <p>1Pk Max</p> <p>10 dBm 0 dBm -10 dBm -20 dBm -30 dBm -40 dBm -50 dBm -60 dBm -70 dBm</p> <p>M1[1] -5.15 dBm 2.4557160 GHz M2[1] -56.80 dBm 2.4835000 GHz M2 2.4835000 GHz</p> <p>D1 -25.150 dBm</p> <p>Start 2.452 GHz 691 pts Stop 2.5 GHz</p> <table border="1"> <thead> <tr> <th>Type</th> <th>Ref</th> <th>Trc</th> <th>X-value</th> <th>Y-value</th> <th>Function</th> <th>Function Result</th> </tr> </thead> <tbody> <tr> <td>M1</td> <td>1</td> <td></td> <td>2.455716 GHz</td> <td>-5.15 dBm</td> <td></td> <td></td> </tr> <tr> <td>M2</td> <td>1</td> <td></td> <td>2.4835 GHz</td> <td>-56.80 dBm</td> <td></td> <td></td> </tr> <tr> <td>M3</td> <td>1</td> <td></td> <td>2.5 GHz</td> <td>-58.05 dBm</td> <td></td> <td></td> </tr> <tr> <td>M4</td> <td>1</td> <td></td> <td>2.485113 GHz</td> <td>-55.15 dBm</td> <td></td> <td></td> </tr> </tbody> </table>			Type	Ref	Trc	X-value	Y-value	Function	Function Result	M1	1		2.455716 GHz	-5.15 dBm			M2	1		2.4835 GHz	-56.80 dBm			M3	1		2.5 GHz	-58.05 dBm			M4	1		2.485113 GHz	-55.15 dBm									
Type	Ref	Trc	X-value	Y-value	Function	Function Result																																							
M1	1		2.455716 GHz	-5.15 dBm																																									
M2	1		2.4835 GHz	-56.80 dBm																																									
M3	1		2.5 GHz	-58.05 dBm																																									
M4	1		2.485113 GHz	-55.15 dBm																																									

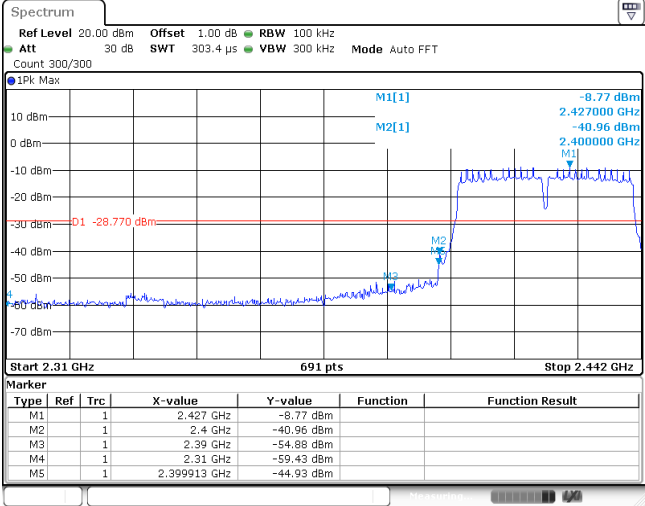
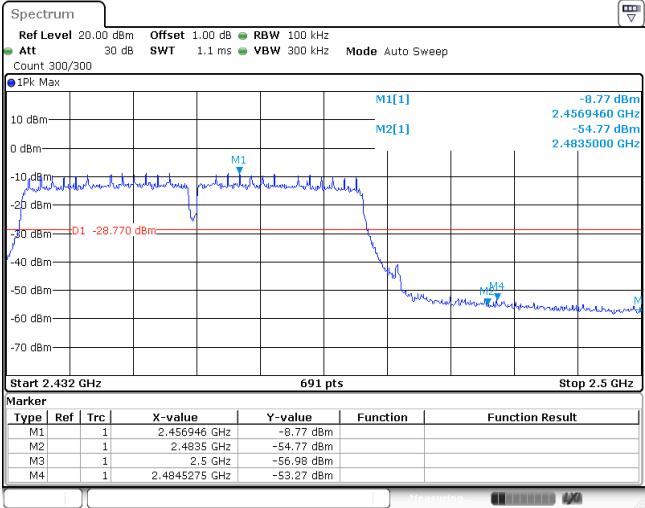
Test Item:	Bandedge	802.11 n(HT40)	Antenna 1																																										
CH03	 <p>Marker</p> <table border="1"> <thead> <tr> <th>Type</th> <th>Ref</th> <th>Trc</th> <th>X-value</th> <th>Y-value</th> <th>Function</th> <th>Function Result</th> </tr> </thead> <tbody> <tr> <td>M1</td> <td>1</td> <td></td> <td>2.427 GHz</td> <td>-8.77 dBm</td> <td></td> <td></td> </tr> <tr> <td>M2</td> <td>1</td> <td></td> <td>2.4 GHz</td> <td>-40.96 dBm</td> <td></td> <td></td> </tr> <tr> <td>M3</td> <td>1</td> <td></td> <td>2.39 GHz</td> <td>-54.88 dBm</td> <td></td> <td></td> </tr> <tr> <td>M4</td> <td>1</td> <td></td> <td>2.31 GHz</td> <td>-59.43 dBm</td> <td></td> <td></td> </tr> <tr> <td>M5</td> <td>1</td> <td></td> <td>2.399913 GHz</td> <td>-44.93 dBm</td> <td></td> <td></td> </tr> </tbody> </table>			Type	Ref	Trc	X-value	Y-value	Function	Function Result	M1	1		2.427 GHz	-8.77 dBm			M2	1		2.4 GHz	-40.96 dBm			M3	1		2.39 GHz	-54.88 dBm			M4	1		2.31 GHz	-59.43 dBm			M5	1		2.399913 GHz	-44.93 dBm		
Type	Ref	Trc	X-value	Y-value	Function	Function Result																																							
M1	1		2.427 GHz	-8.77 dBm																																									
M2	1		2.4 GHz	-40.96 dBm																																									
M3	1		2.39 GHz	-54.88 dBm																																									
M4	1		2.31 GHz	-59.43 dBm																																									
M5	1		2.399913 GHz	-44.93 dBm																																									
CH09	 <p>Marker</p> <table border="1"> <thead> <tr> <th>Type</th> <th>Ref</th> <th>Trc</th> <th>X-value</th> <th>Y-value</th> <th>Function</th> <th>Function Result</th> </tr> </thead> <tbody> <tr> <td>M1</td> <td>1</td> <td></td> <td>2.456946 GHz</td> <td>-8.77 dBm</td> <td></td> <td></td> </tr> <tr> <td>M2</td> <td>1</td> <td></td> <td>2.4835 GHz</td> <td>-54.77 dBm</td> <td></td> <td></td> </tr> <tr> <td>M3</td> <td>1</td> <td></td> <td>2.5 GHz</td> <td>-56.98 dBm</td> <td></td> <td></td> </tr> <tr> <td>M4</td> <td>1</td> <td></td> <td>2.4845275 GHz</td> <td>-53.27 dBm</td> <td></td> <td></td> </tr> </tbody> </table>			Type	Ref	Trc	X-value	Y-value	Function	Function Result	M1	1		2.456946 GHz	-8.77 dBm			M2	1		2.4835 GHz	-54.77 dBm			M3	1		2.5 GHz	-56.98 dBm			M4	1		2.4845275 GHz	-53.27 dBm									
Type	Ref	Trc	X-value	Y-value	Function	Function Result																																							
M1	1		2.456946 GHz	-8.77 dBm																																									
M2	1		2.4835 GHz	-54.77 dBm																																									
M3	1		2.5 GHz	-56.98 dBm																																									
M4	1		2.4845275 GHz	-53.27 dBm																																									

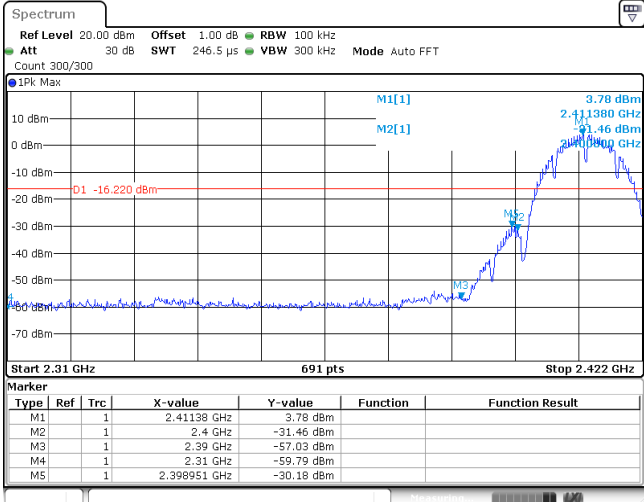
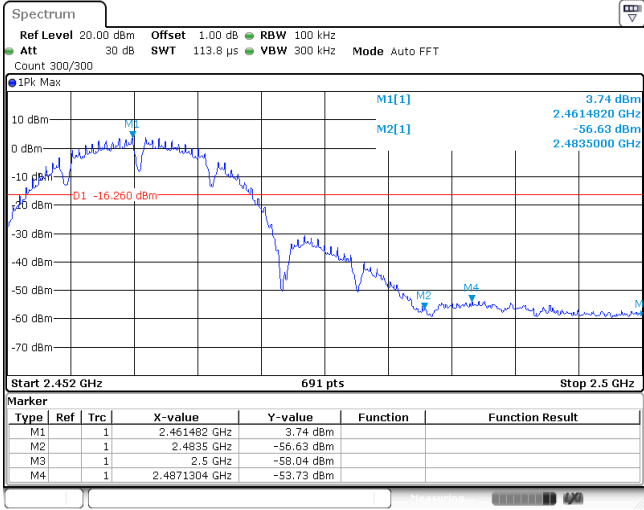
Test Item:	Bandedge	802.11 b	Antenna 2																																										
CH01	 <p>Spectrum</p> <p>Ref Level 20.00 dBm Offset 1.00 dB RBW 100 kHz Att 30 dB SWT 246.5 μs VBW 300 kHz Mode Auto FFT Count 300/300</p> <p>1Pk Max</p> <p>10 dBm 0 dBm -10 dBm -20 dBm -30 dBm -40 dBm -50 dBm -60 dBm -70 dBm</p> <p>M1[1] 3.78 dBm 2.411380 GHz M2[1] -31.46 dBm 2.398951 GHz</p> <p>D1 -16.220 dBm</p> <p>Start 2.31 GHz 691 pts Stop 2.422 GHz</p> <table border="1"> <thead> <tr> <th>Type</th> <th>Ref</th> <th>Trc</th> <th>X-value</th> <th>Y-value</th> <th>Function</th> <th>Function Result</th> </tr> </thead> <tbody> <tr> <td>M1</td> <td>1</td> <td></td> <td>2.41138 GHz</td> <td>3.78 dBm</td> <td></td> <td></td> </tr> <tr> <td>M2</td> <td>1</td> <td></td> <td>2.4 GHz</td> <td>-31.46 dBm</td> <td></td> <td></td> </tr> <tr> <td>M3</td> <td>1</td> <td></td> <td>2.39 GHz</td> <td>-57.03 dBm</td> <td></td> <td></td> </tr> <tr> <td>M4</td> <td>1</td> <td></td> <td>2.31 GHz</td> <td>-59.79 dBm</td> <td></td> <td></td> </tr> <tr> <td>M5</td> <td>1</td> <td></td> <td>2.398951 GHz</td> <td>-30.18 dBm</td> <td></td> <td></td> </tr> </tbody> </table>			Type	Ref	Trc	X-value	Y-value	Function	Function Result	M1	1		2.41138 GHz	3.78 dBm			M2	1		2.4 GHz	-31.46 dBm			M3	1		2.39 GHz	-57.03 dBm			M4	1		2.31 GHz	-59.79 dBm			M5	1		2.398951 GHz	-30.18 dBm		
Type	Ref	Trc	X-value	Y-value	Function	Function Result																																							
M1	1		2.41138 GHz	3.78 dBm																																									
M2	1		2.4 GHz	-31.46 dBm																																									
M3	1		2.39 GHz	-57.03 dBm																																									
M4	1		2.31 GHz	-59.79 dBm																																									
M5	1		2.398951 GHz	-30.18 dBm																																									
CH11	 <p>Spectrum</p> <p>Ref Level 20.00 dBm Offset 1.00 dB RBW 100 kHz Att 30 dB SWT 113.8 μs VBW 300 kHz Mode Auto FFT Count 300/300</p> <p>1Pk Max</p> <p>10 dBm 0 dBm -10 dBm -20 dBm -30 dBm -40 dBm -50 dBm -60 dBm -70 dBm</p> <p>M1[1] 3.74 dBm 2.4614820 GHz M2[1] -56.63 dBm 2.4835000 GHz</p> <p>D1 -16.260 dBm</p> <p>Start 2.452 GHz 691 pts Stop 2.5 GHz</p> <table border="1"> <thead> <tr> <th>Type</th> <th>Ref</th> <th>Trc</th> <th>X-value</th> <th>Y-value</th> <th>Function</th> <th>Function Result</th> </tr> </thead> <tbody> <tr> <td>M1</td> <td>1</td> <td></td> <td>2.461482 GHz</td> <td>3.74 dBm</td> <td></td> <td></td> </tr> <tr> <td>M2</td> <td>1</td> <td></td> <td>2.4835 GHz</td> <td>-56.63 dBm</td> <td></td> <td></td> </tr> <tr> <td>M3</td> <td>1</td> <td></td> <td>2.5 GHz</td> <td>-58.04 dBm</td> <td></td> <td></td> </tr> <tr> <td>M4</td> <td>1</td> <td></td> <td>2.4871304 GHz</td> <td>-53.73 dBm</td> <td></td> <td></td> </tr> </tbody> </table>			Type	Ref	Trc	X-value	Y-value	Function	Function Result	M1	1		2.461482 GHz	3.74 dBm			M2	1		2.4835 GHz	-56.63 dBm			M3	1		2.5 GHz	-58.04 dBm			M4	1		2.4871304 GHz	-53.73 dBm									
Type	Ref	Trc	X-value	Y-value	Function	Function Result																																							
M1	1		2.461482 GHz	3.74 dBm																																									
M2	1		2.4835 GHz	-56.63 dBm																																									
M3	1		2.5 GHz	-58.04 dBm																																									
M4	1		2.4871304 GHz	-53.73 dBm																																									

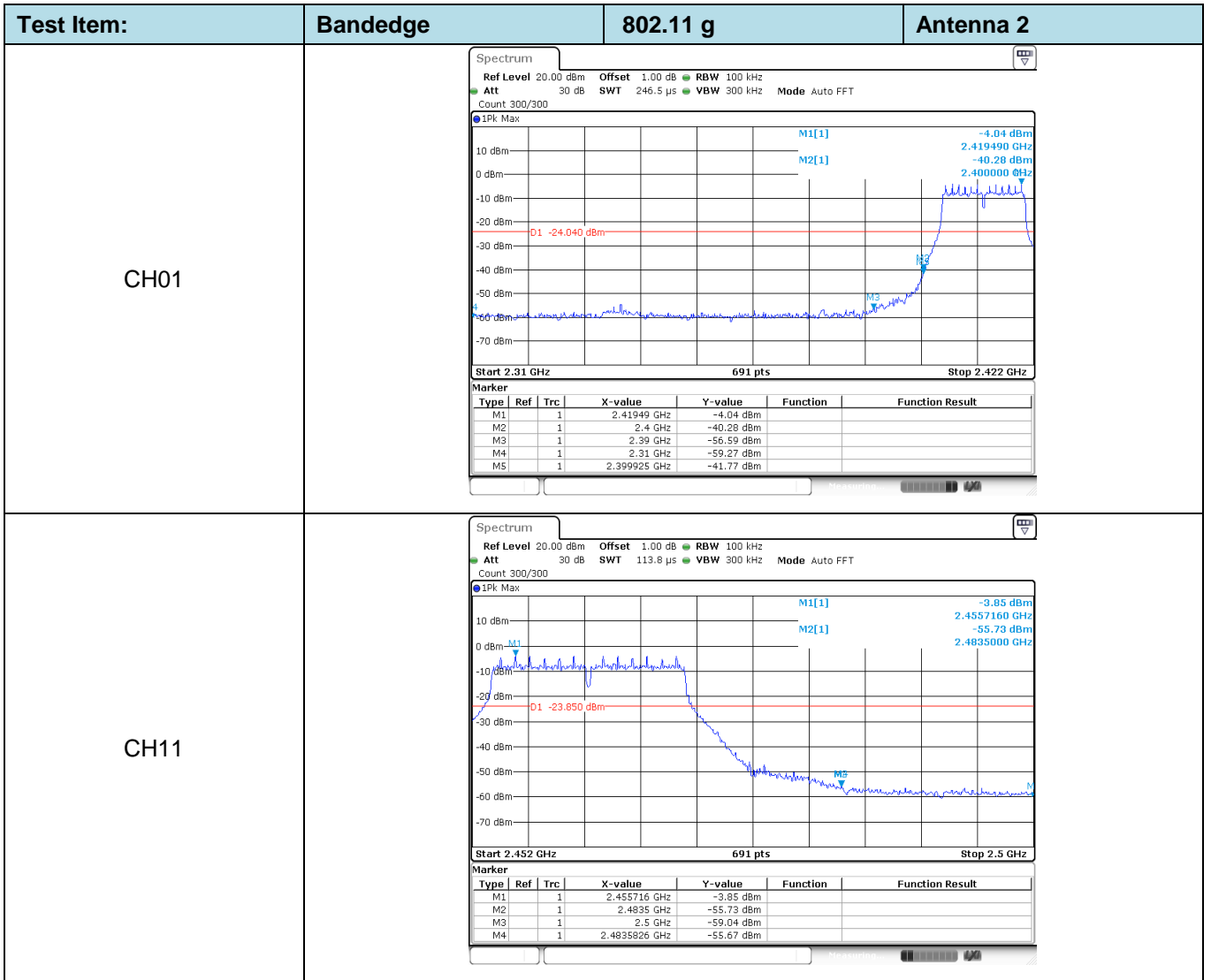

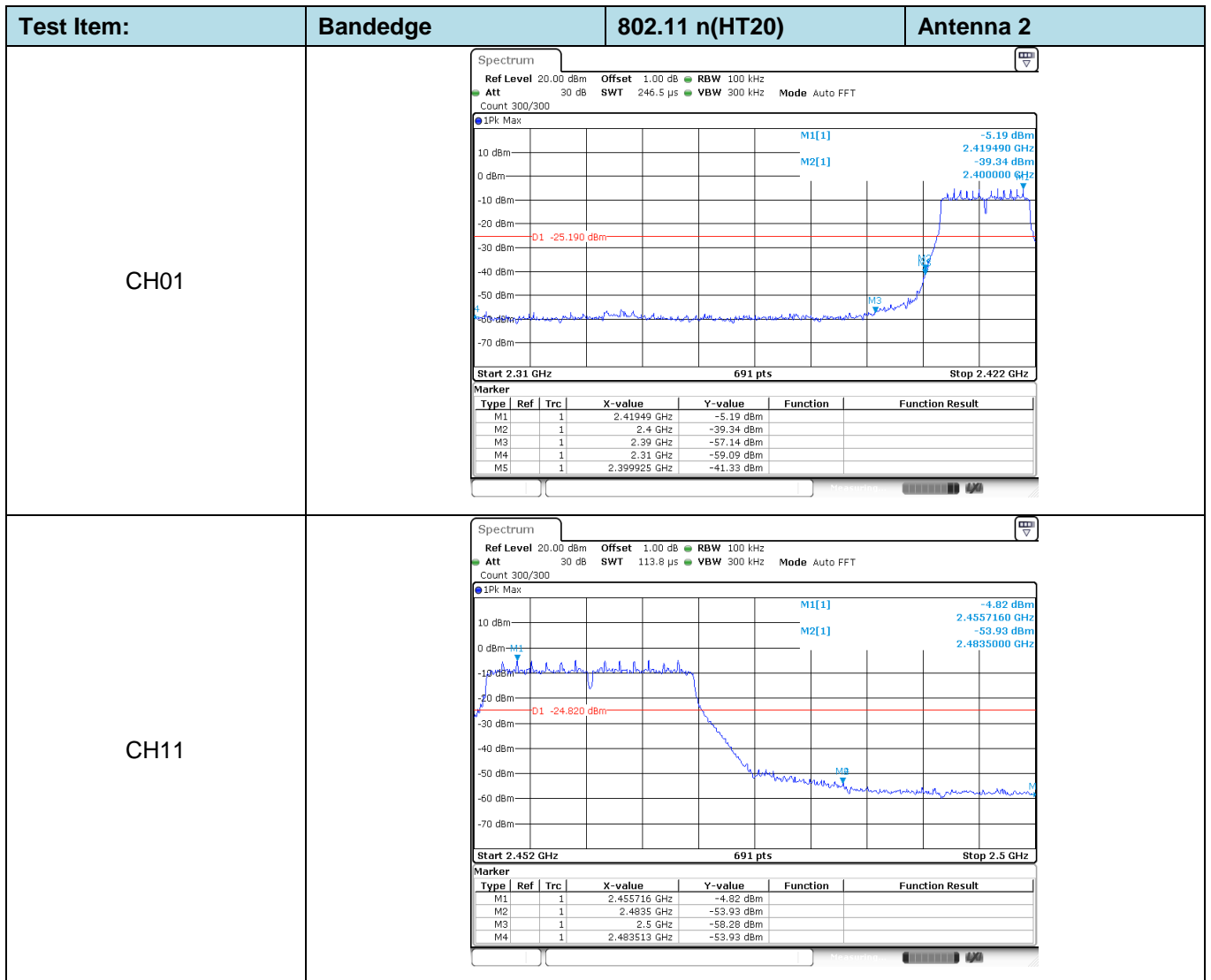

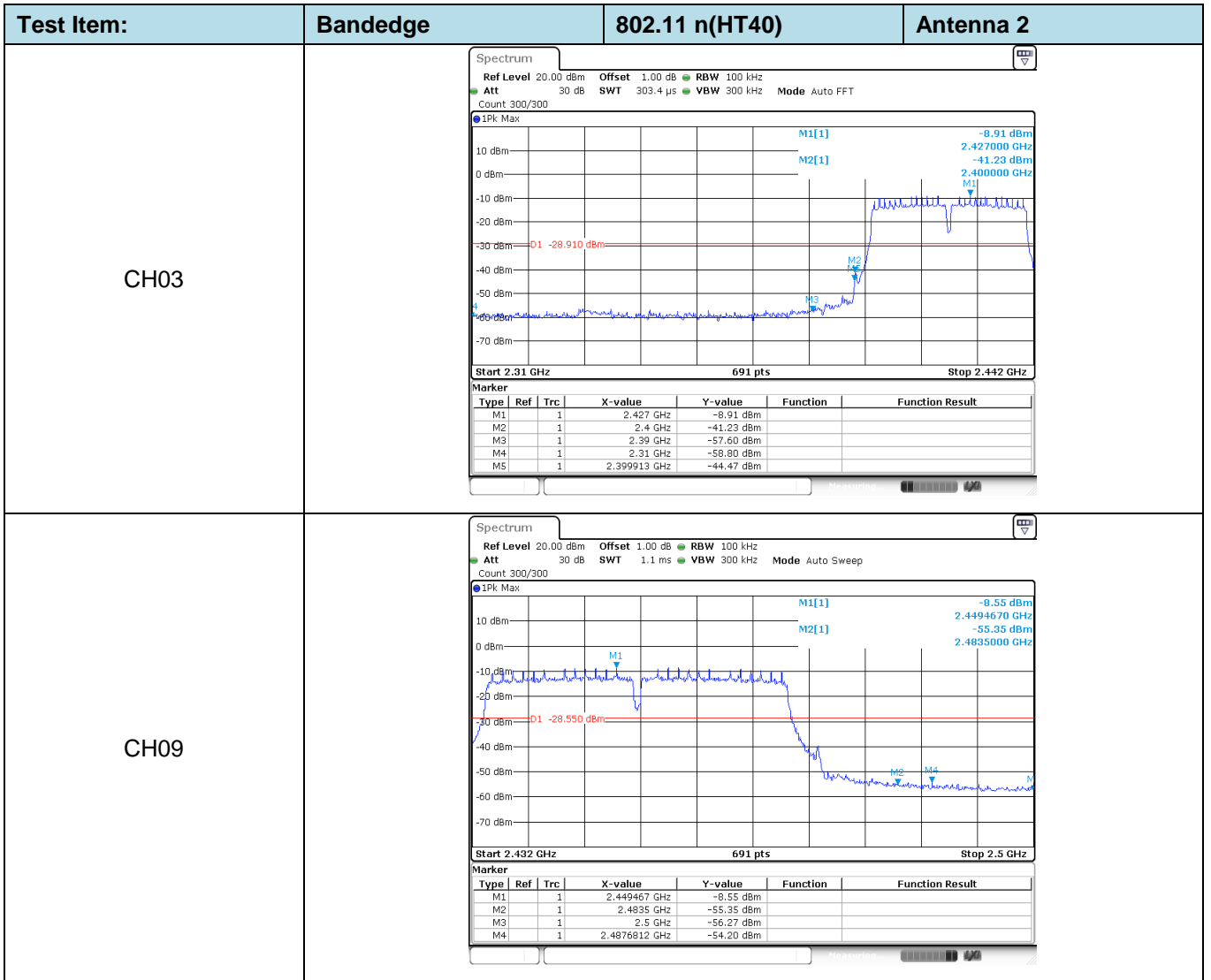

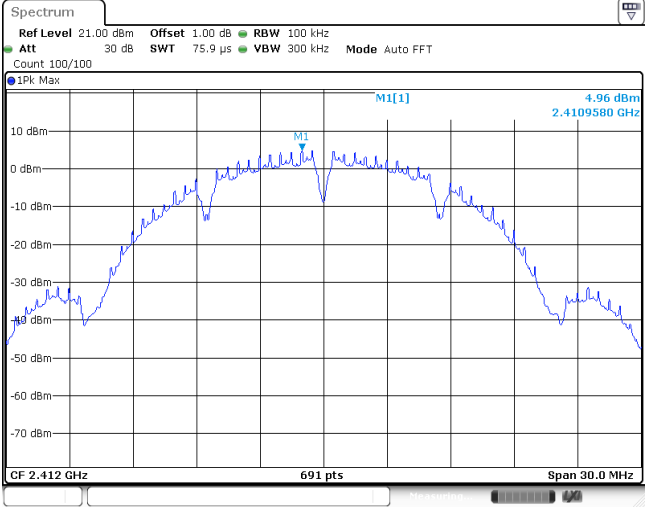
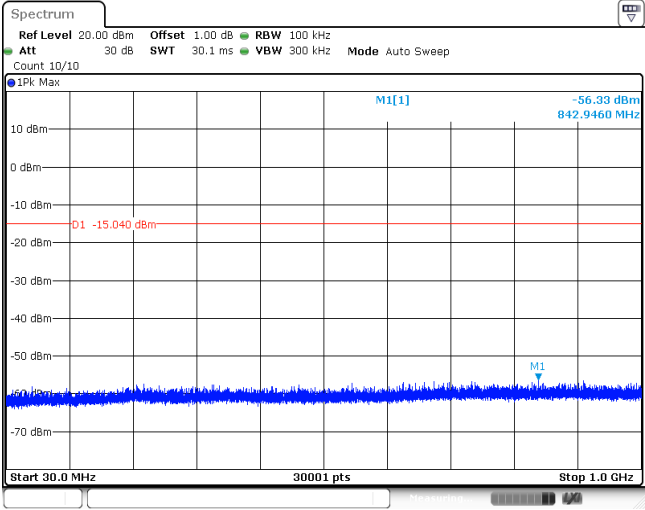
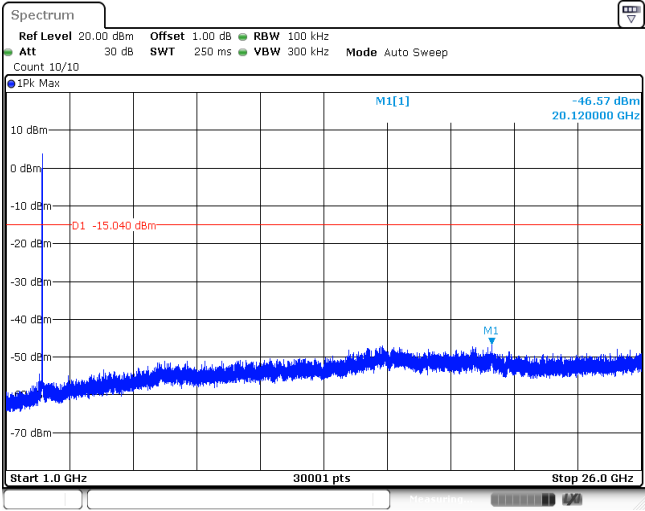
Test Item:	SE	802.11 b	Antenna 1
Reference level CH01			
CH01			
CH01			

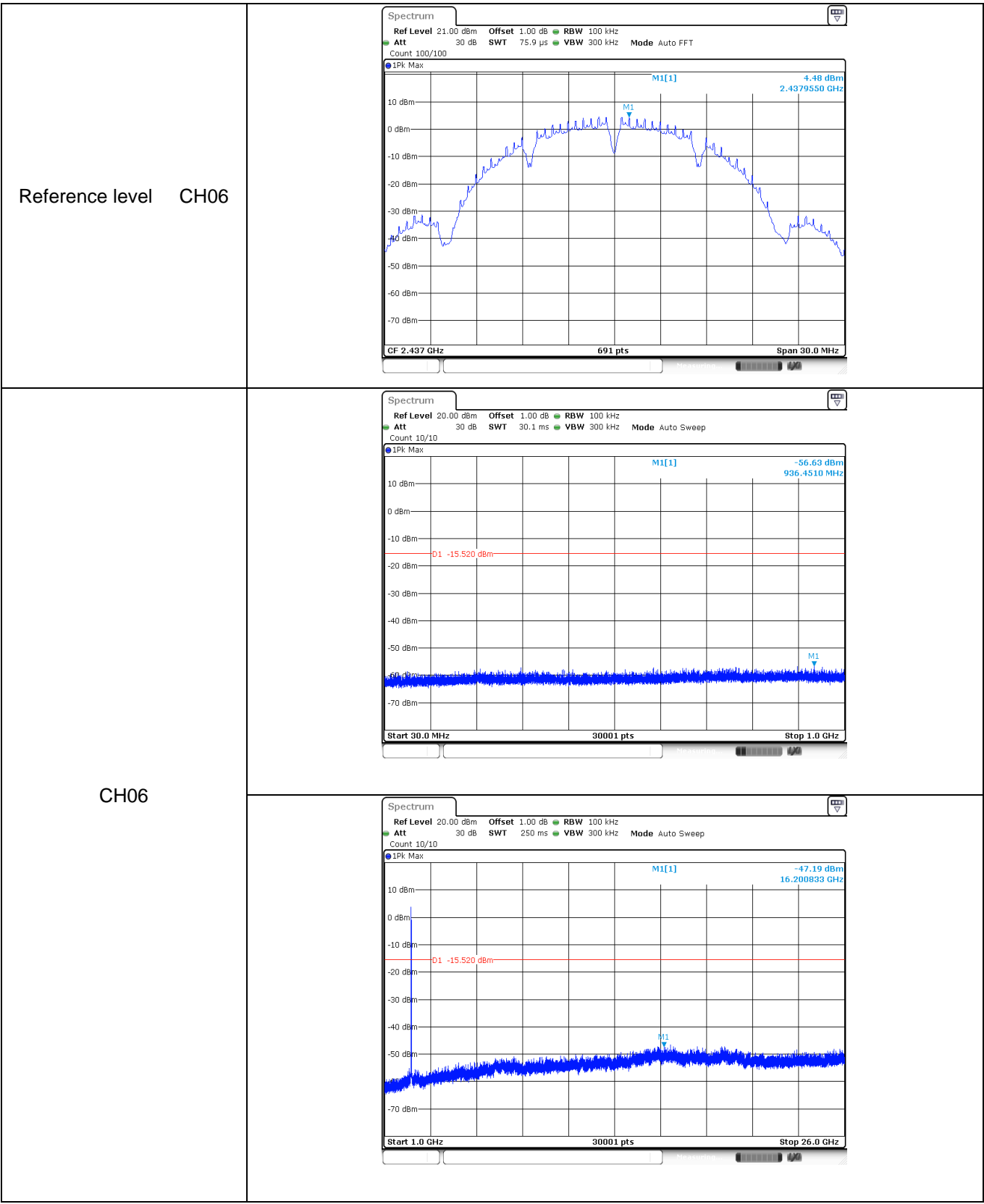

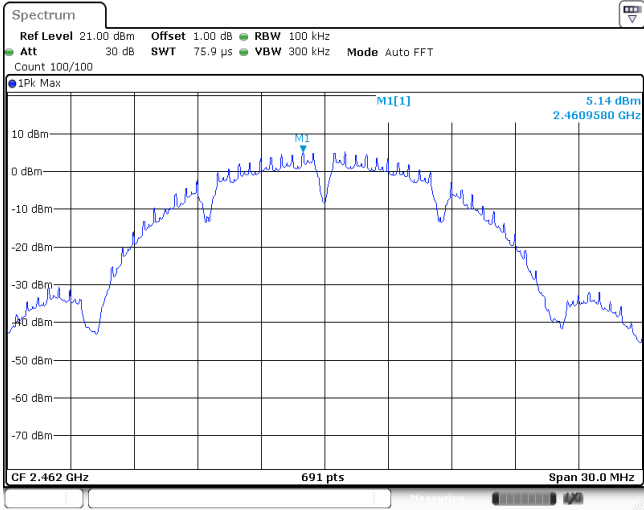
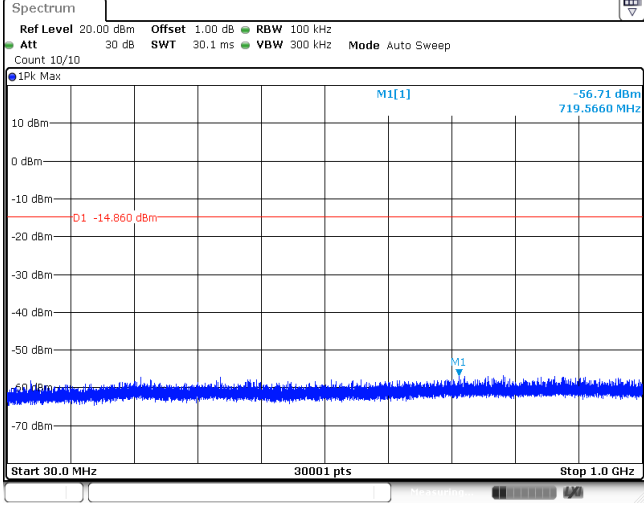
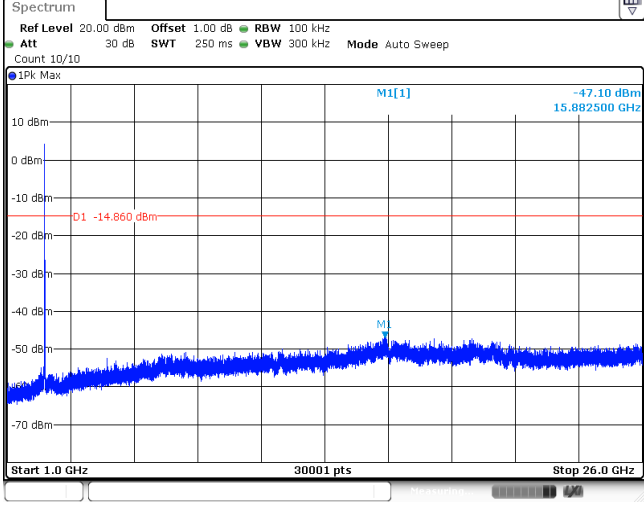
Reference level CH11	 <p>Spectrum</p> <p>Ref Level 21.00 dBm Offset 1.00 dB RBW 100 kHz</p> <p>Att 30 dB SWT 75.9 μs VBW 300 kHz Mode Auto FFT</p> <p>Count 100/100</p> <p>1Pk Max</p> <p>M1[1] 5.14 dBm 2.4609580 GHz</p> <p>CF 2.462 GHz 691 pts Span 30.0 MHz</p>
CH11	 <p>Spectrum</p> <p>Ref Level 20.00 dBm Offset 1.00 dB RBW 100 kHz</p> <p>Att 30 dB SWT 30.1 ms VBW 300 kHz Mode Auto Sweep</p> <p>Count 10/10</p> <p>1Pk Max</p> <p>M1[1] -56.71 dBm 719.5660 MHz</p> <p>D1 -14.860 dBm</p> <p>Start 30.0 MHz 30001 pts Stop 1.0 GHz</p>
CH11	 <p>Spectrum</p> <p>Ref Level 20.00 dBm Offset 1.00 dB RBW 100 kHz</p> <p>Att 30 dB SWT 250 ms VBW 300 kHz Mode Auto Sweep</p> <p>Count 10/10</p> <p>1Pk Max</p> <p>M1[1] -47.10 dBm 15.882500 GHz</p> <p>D1 -14.860 dBm</p> <p>Start 1.0 GHz 30001 pts Stop 26.0 GHz</p>

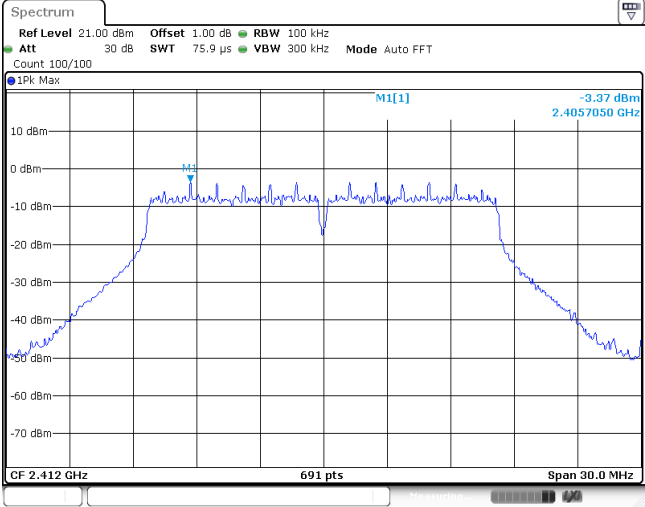
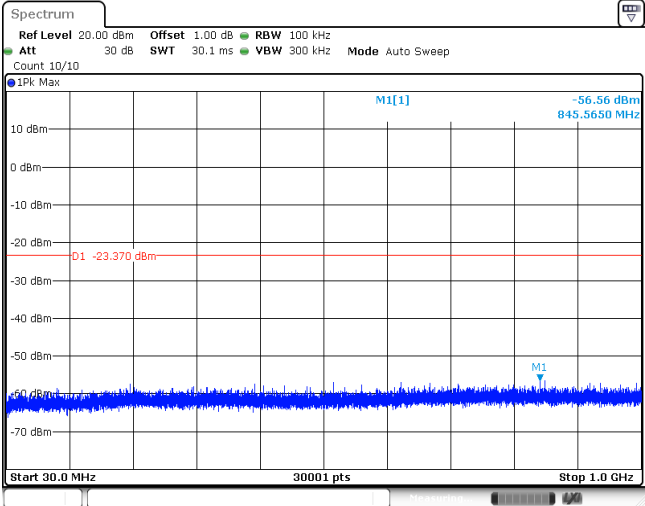
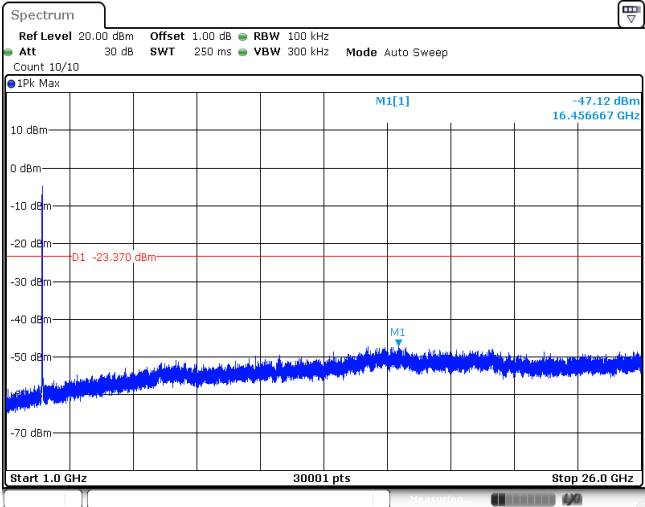
Test Item:	SE	802.11 g	Antenna 1
Reference level CH01			
CH01			
CH01			

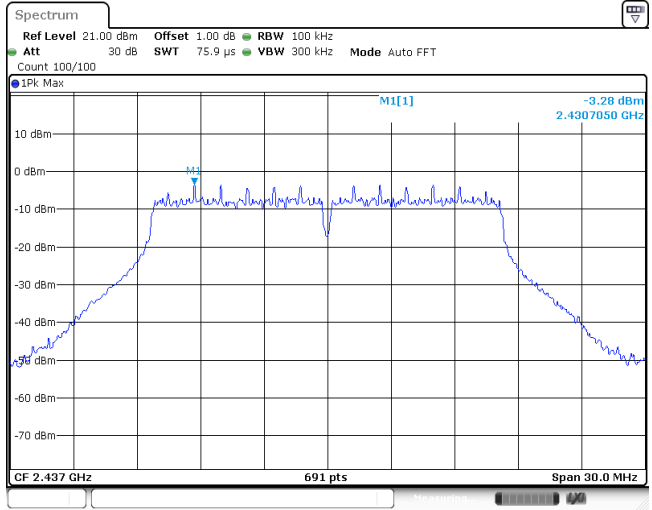
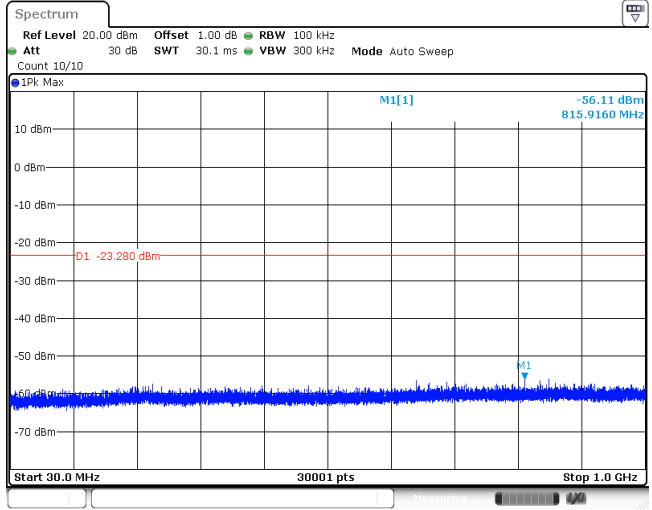
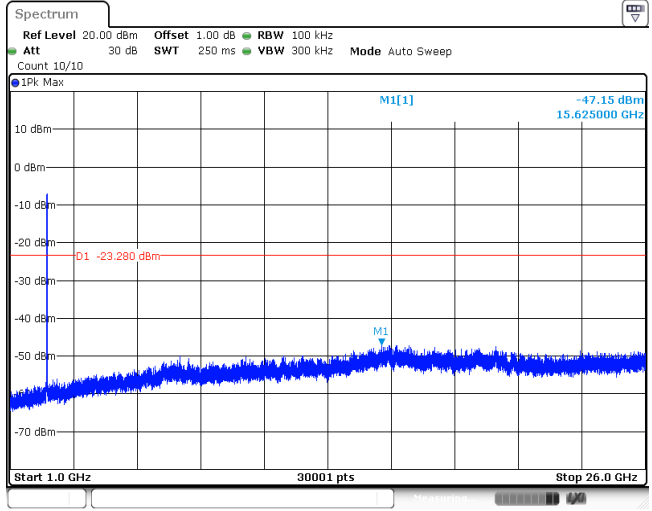
<p>Reference level CH06</p>	
<p>CH06</p>	
	

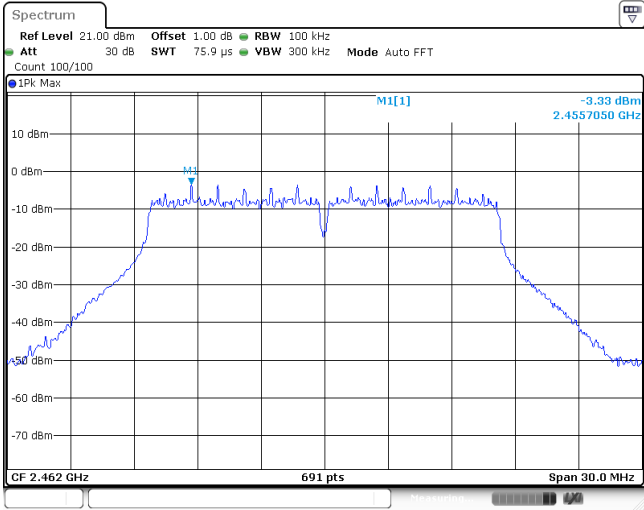
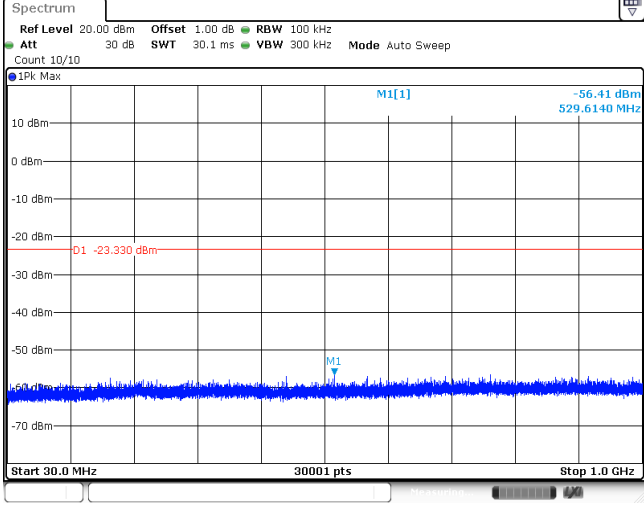
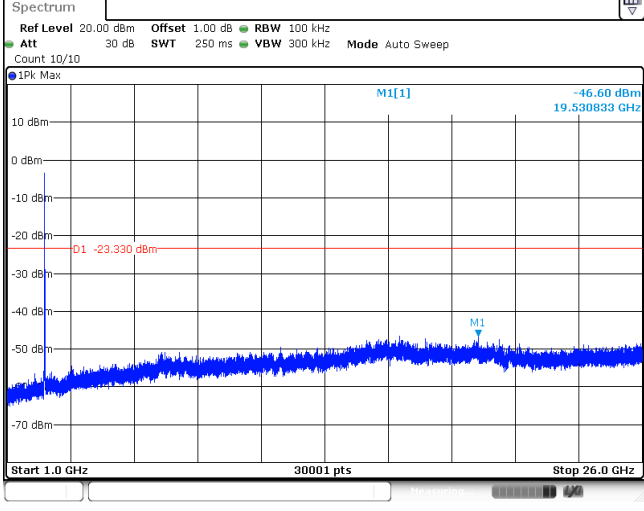
<p>Reference level CH11</p>	
<p>CH11</p>	
<p>CH11</p>	

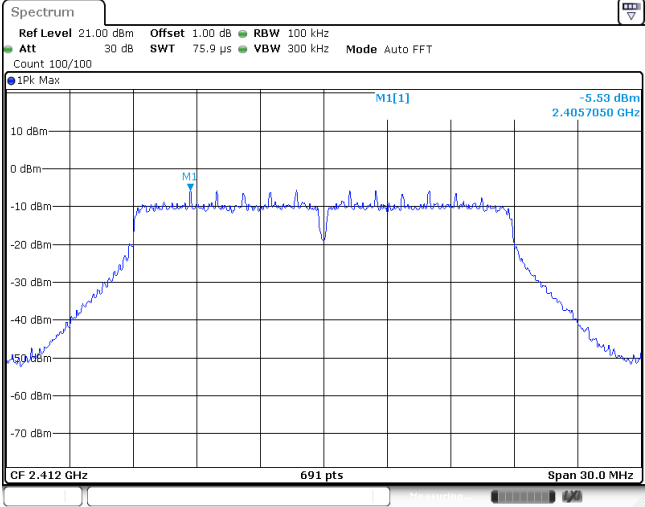
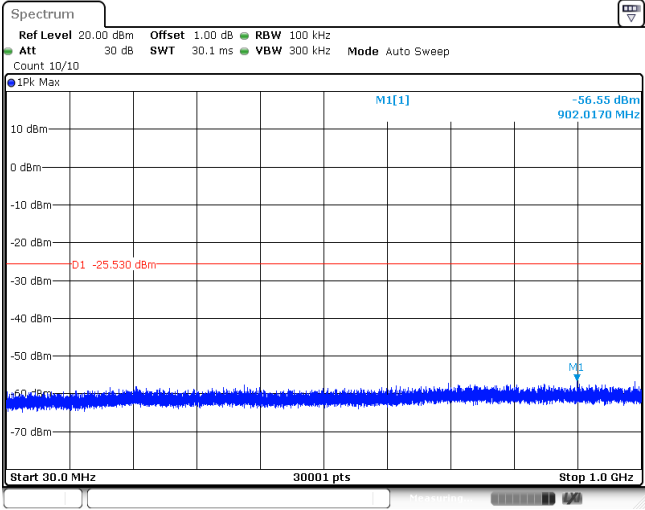
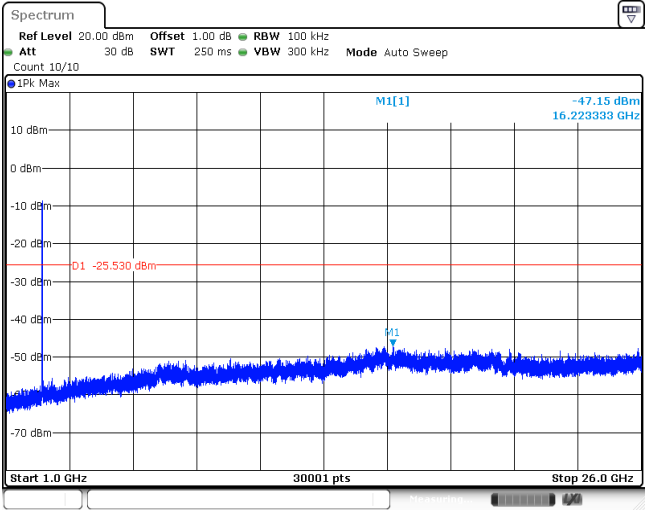
Test Item:	SE	802.11 n(HT20)	Antenna 1
Reference level CH01			
CH01			
CH01			

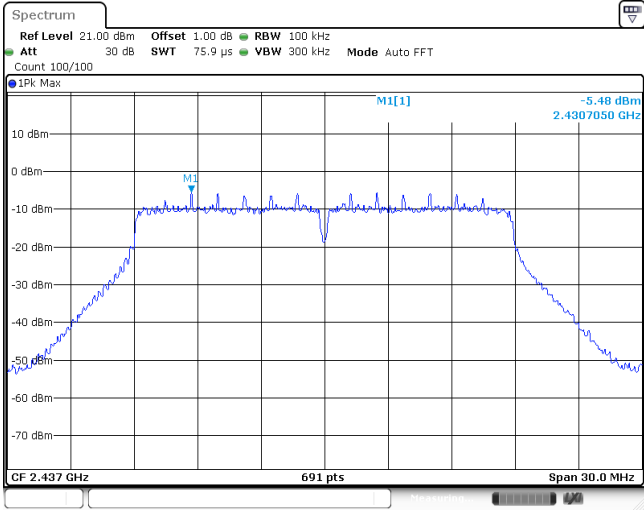
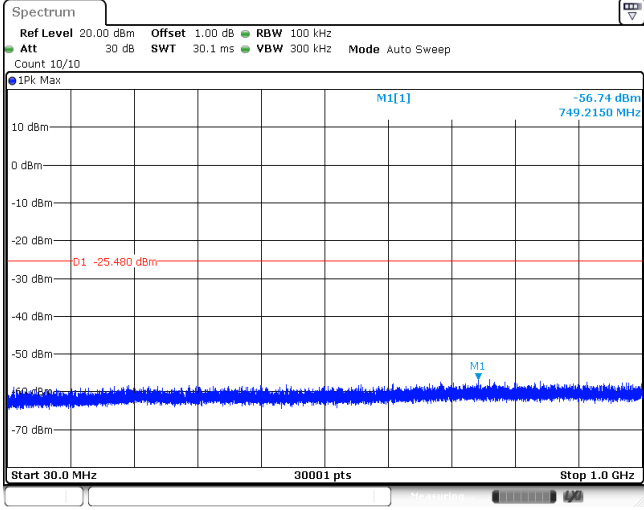
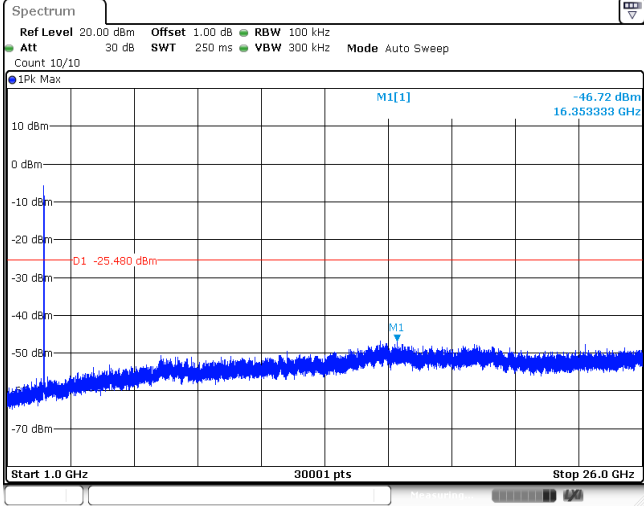
<p>Reference level CH06</p>	
<p>CH06</p>	
<p>CH06</p>	

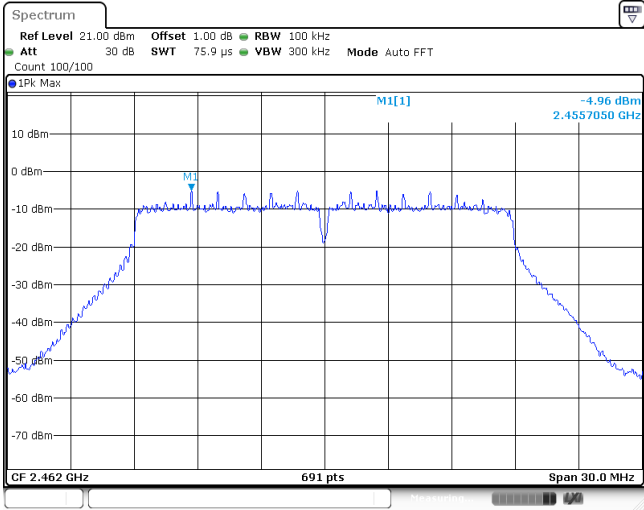
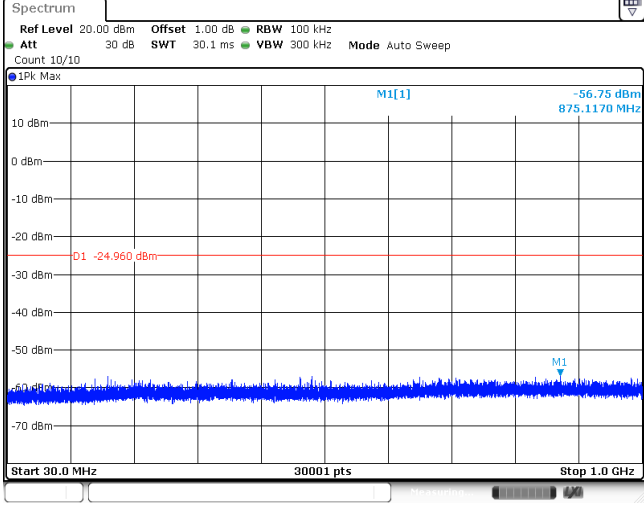
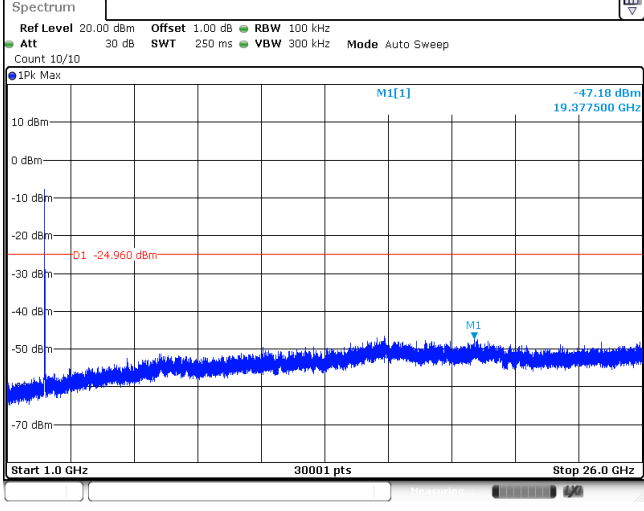
<p>Reference level CH11</p>	
<p>CH11</p>	
<p>CH11</p>	

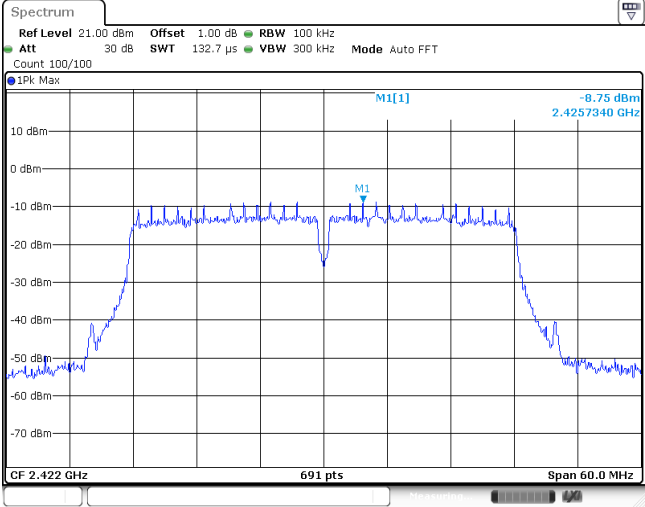
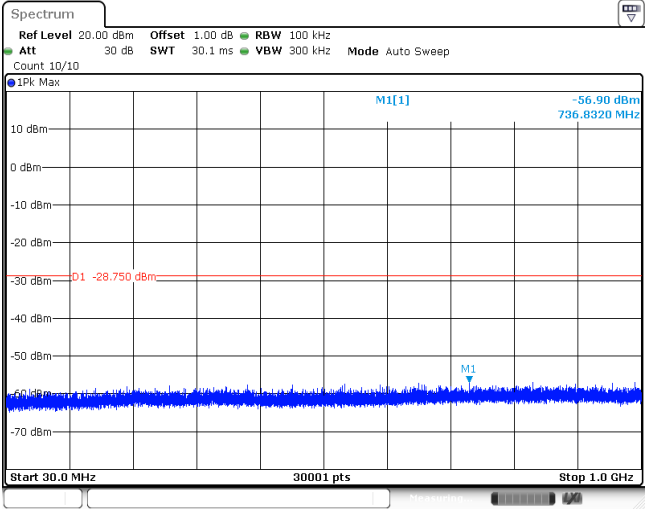
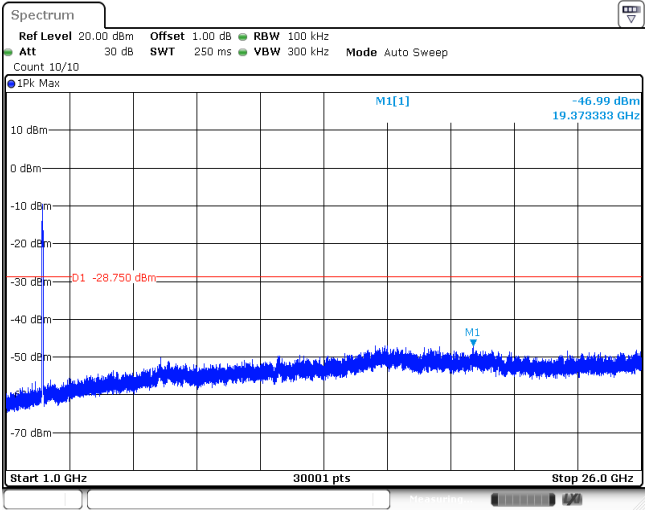
Test Item:	SE	802.11 n(HT40)	Antenna 1
Reference level CH03			
CH03			
CH03			

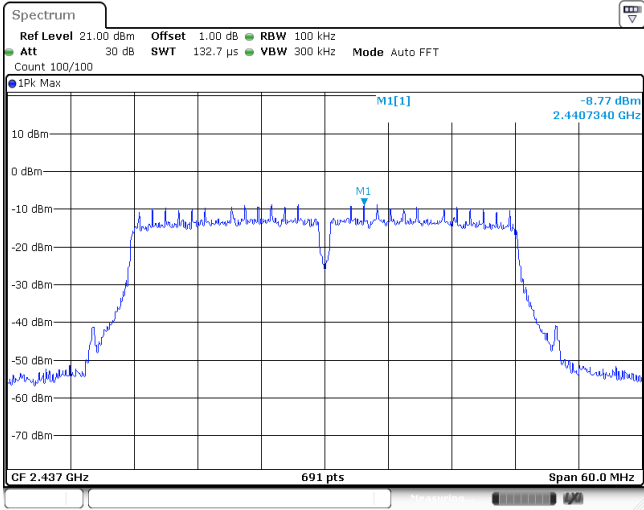
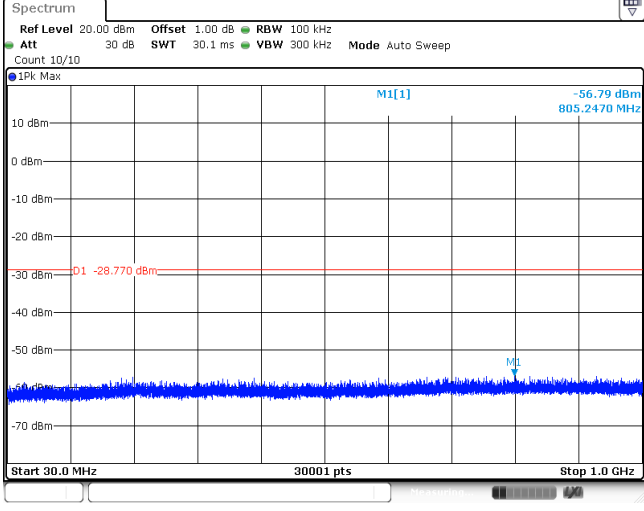
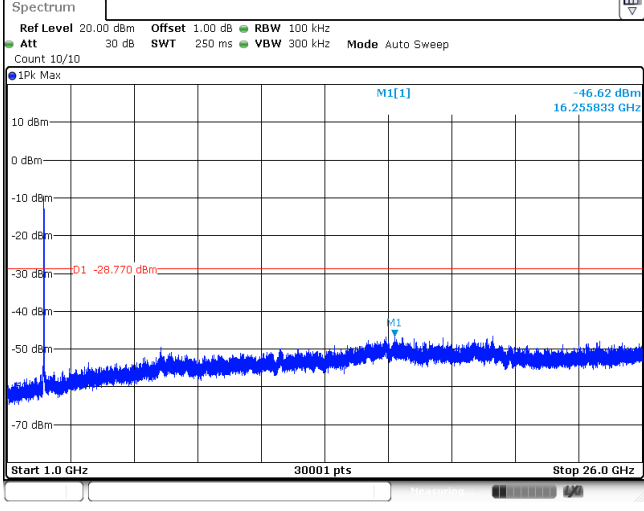
<p>Reference level CH06</p>	
<p>CH06</p>	
	

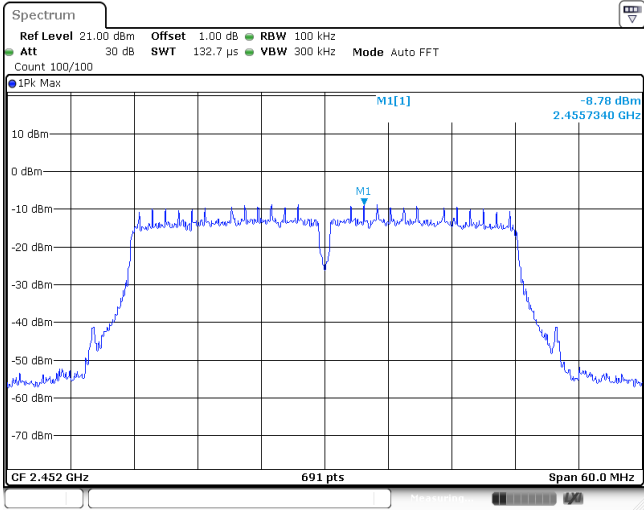
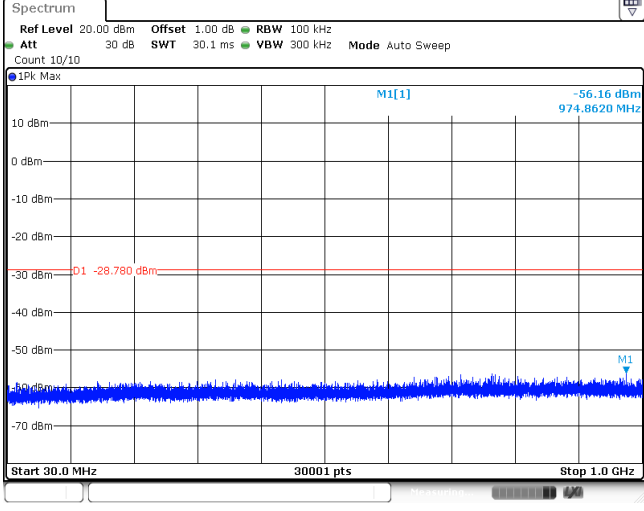
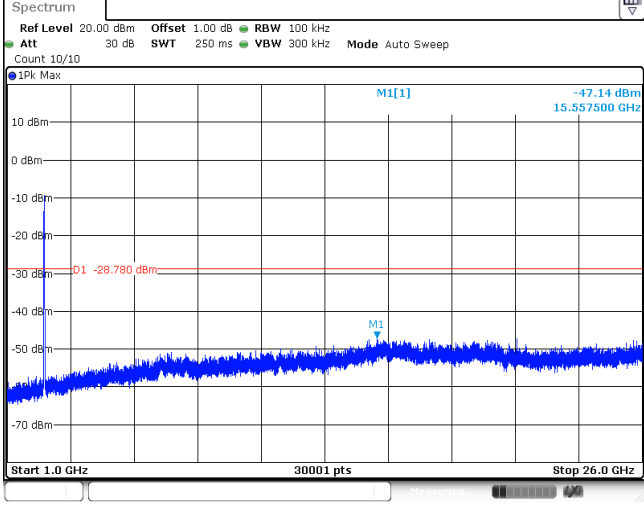
<p>Reference level CH09</p>	
<p>CH09</p>	
<p>CH09</p>	

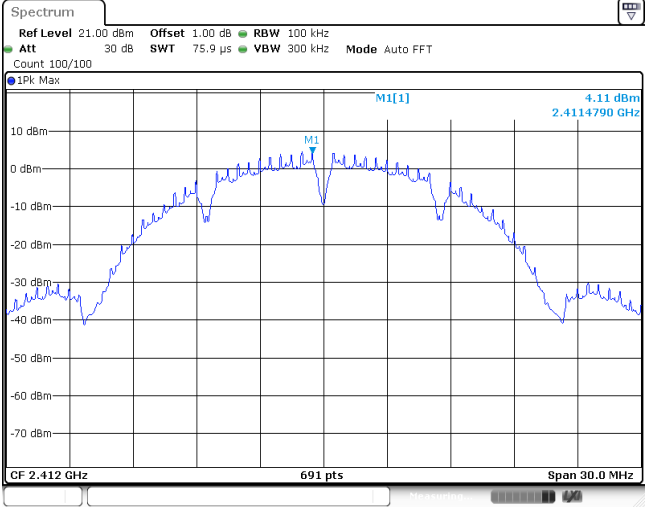
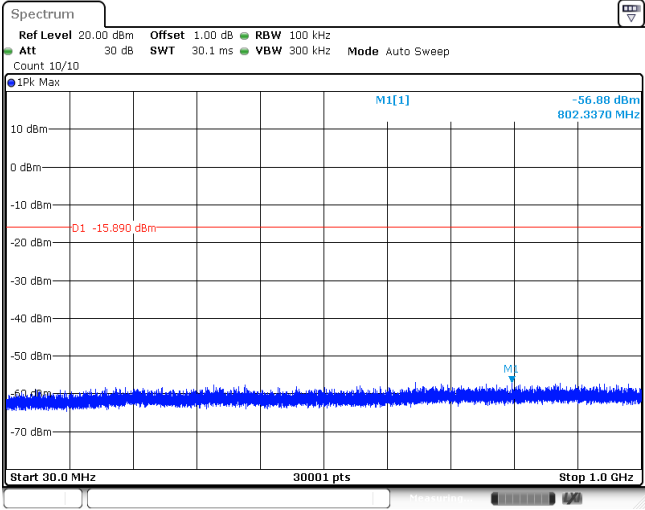
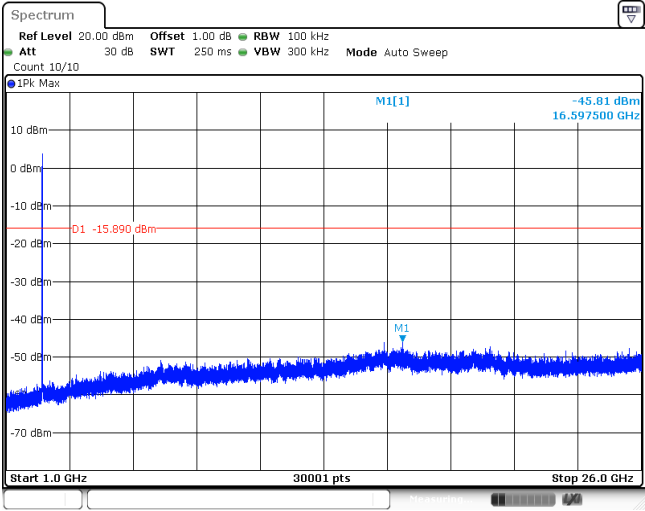
Test Item:	SE	802.11 b	Antenna 2
Reference level CH01			
CH01			
			

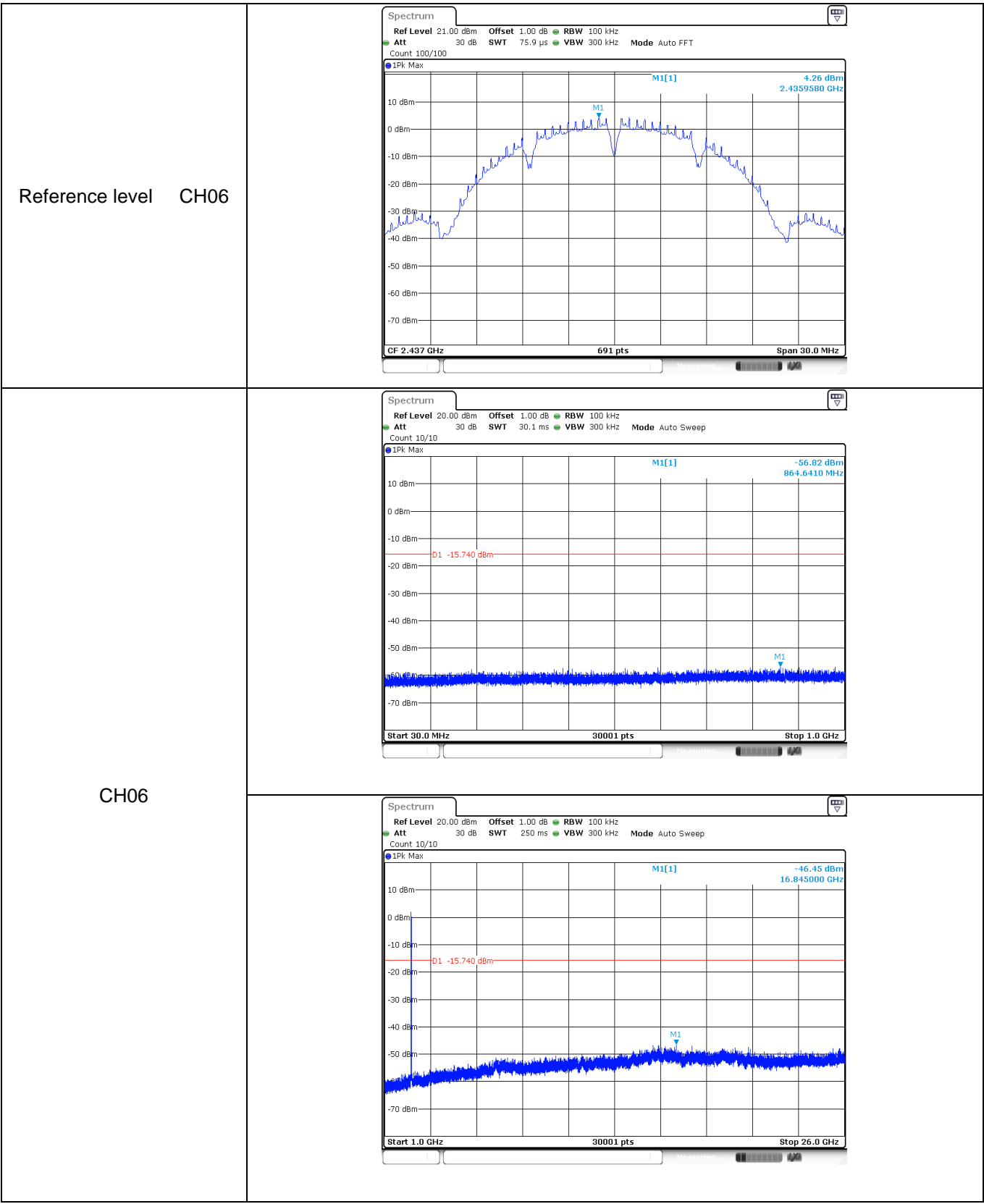

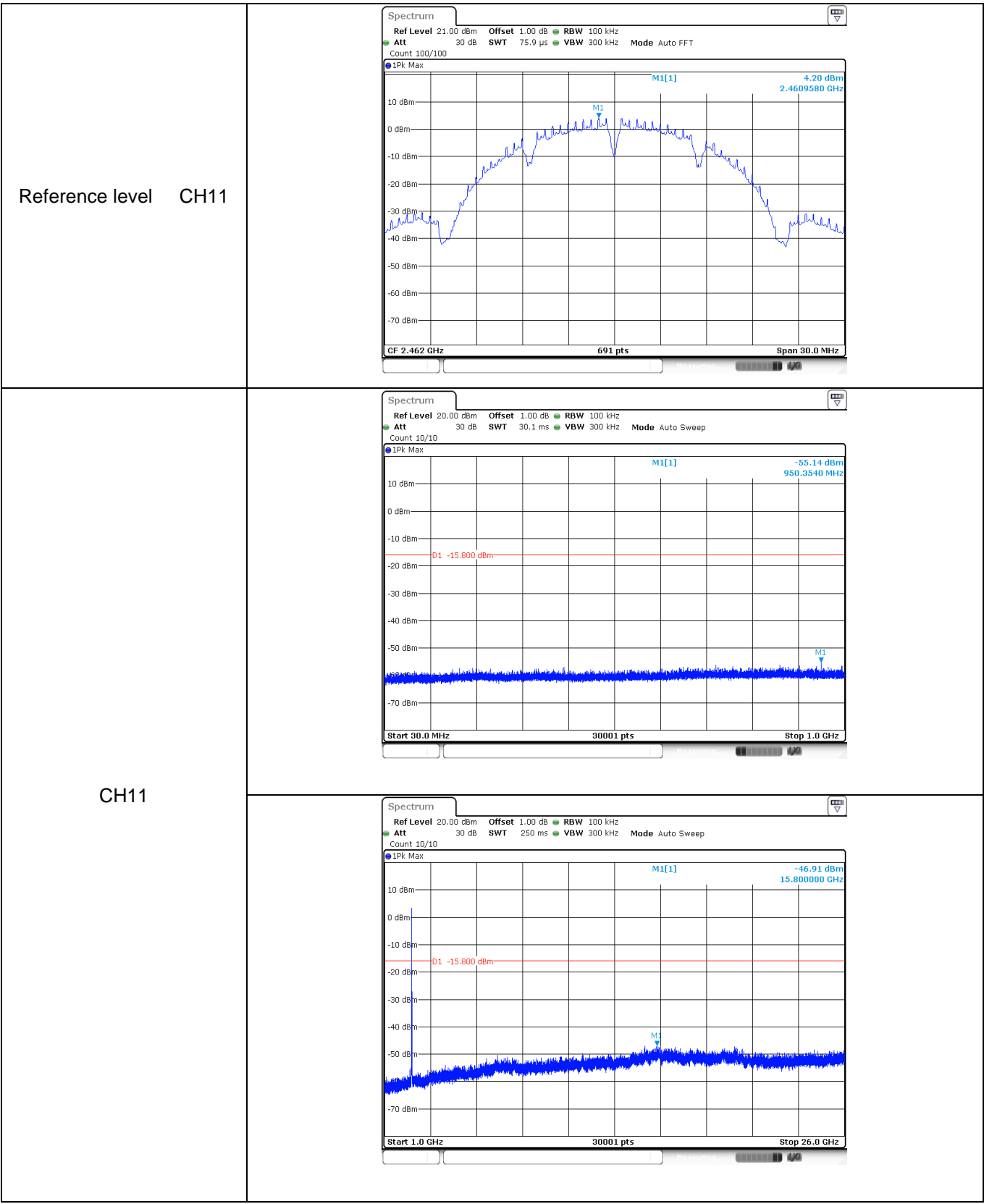

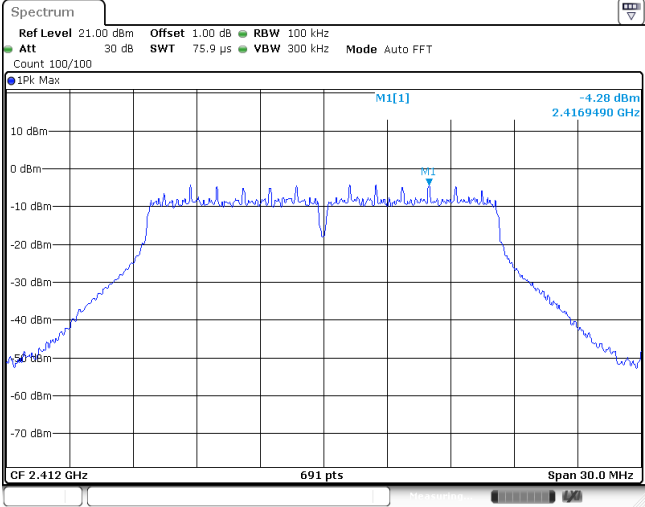
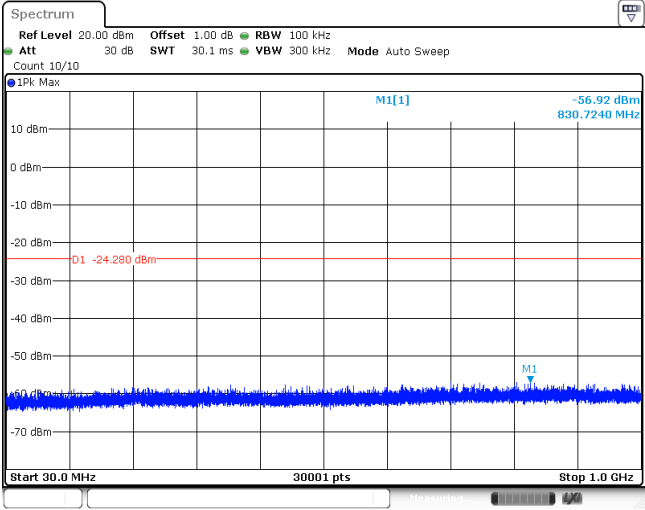
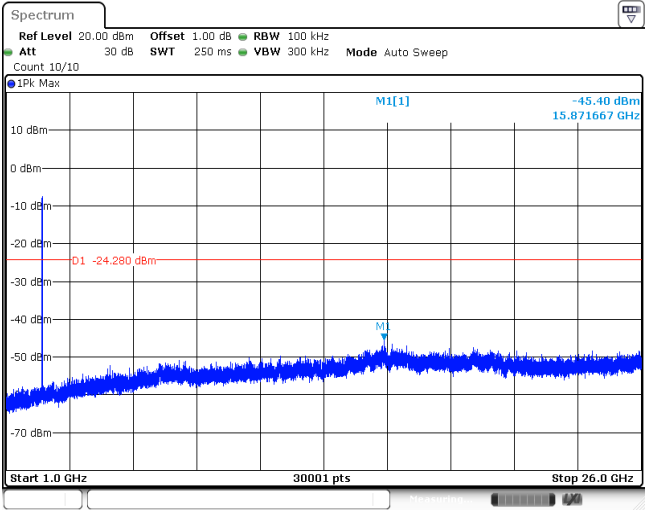
Test Item:	SE	802.11 g	Antenna 2
Reference level CH01			
CH01			
CH01			

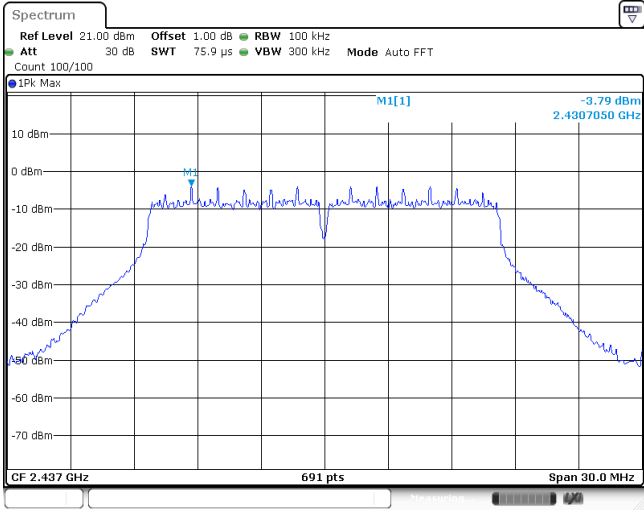
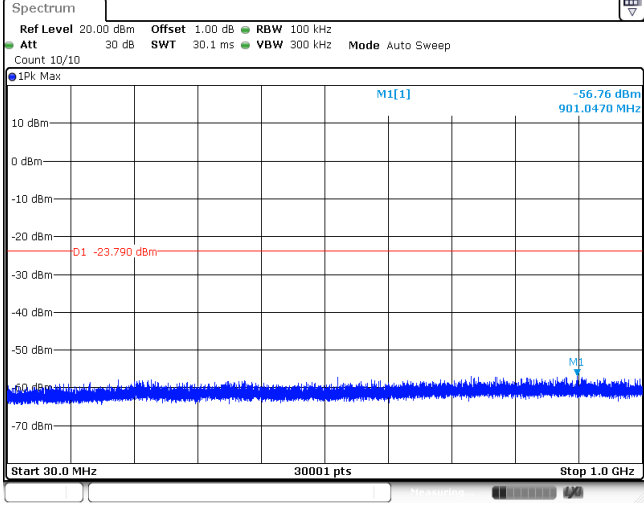
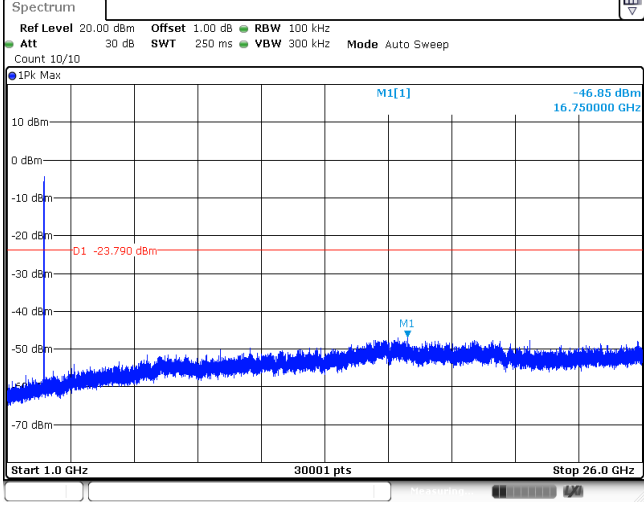
<p>Reference level CH06</p>	
<p>CH06</p>	
	

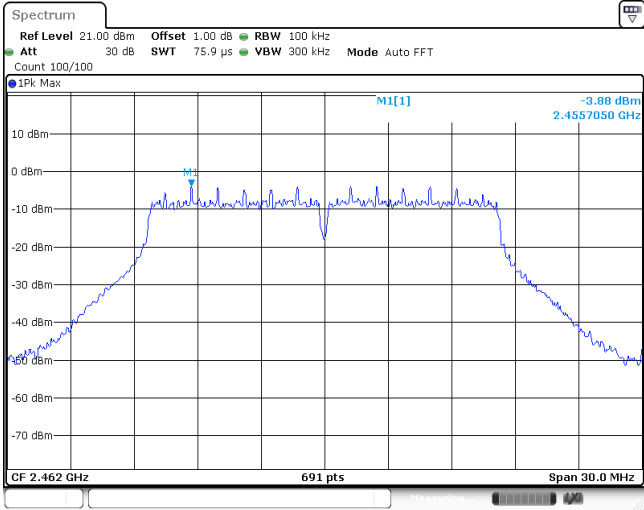
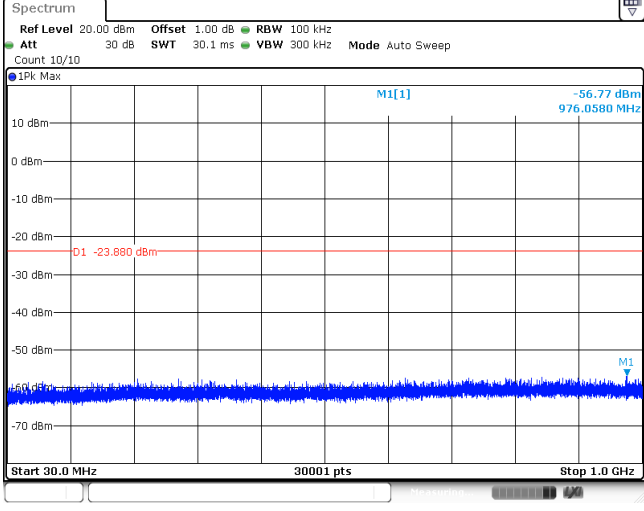
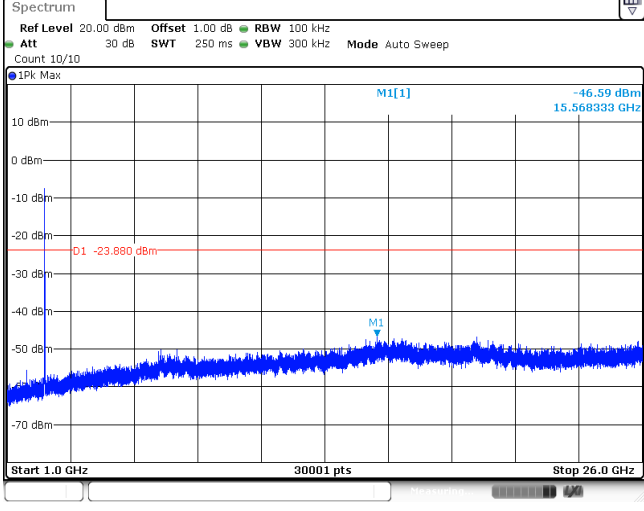
<p>Reference level CH11</p>	
<p>CH11</p>	
<p>CH11</p>	

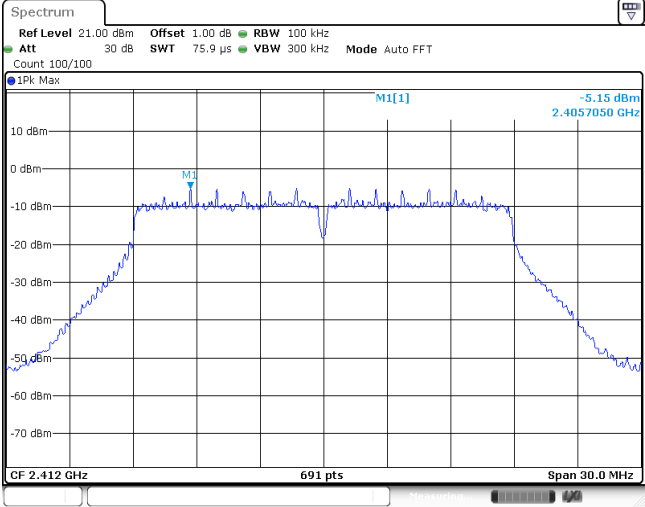
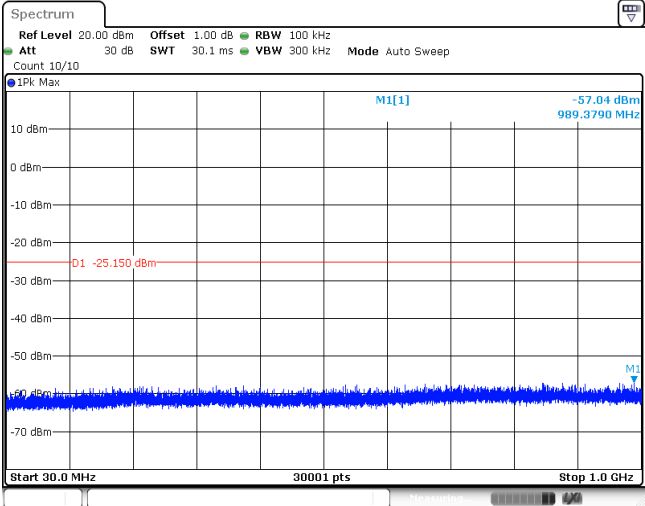
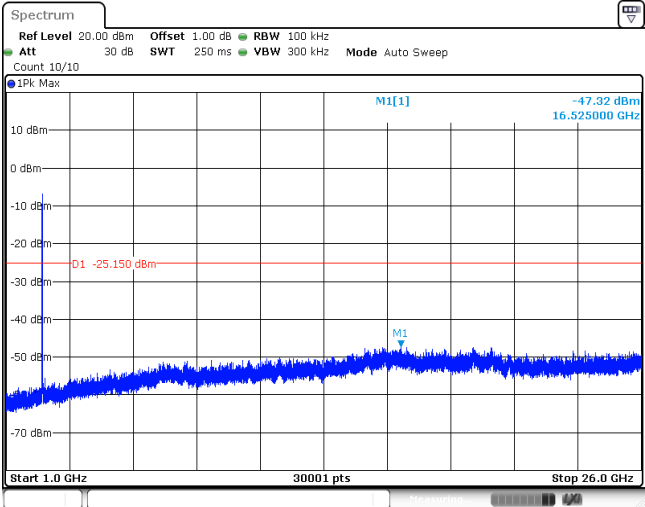
Test Item:	SE	802.11 n(HT20)	Antenna 2
Reference level CH01			
CH01			
CH01			

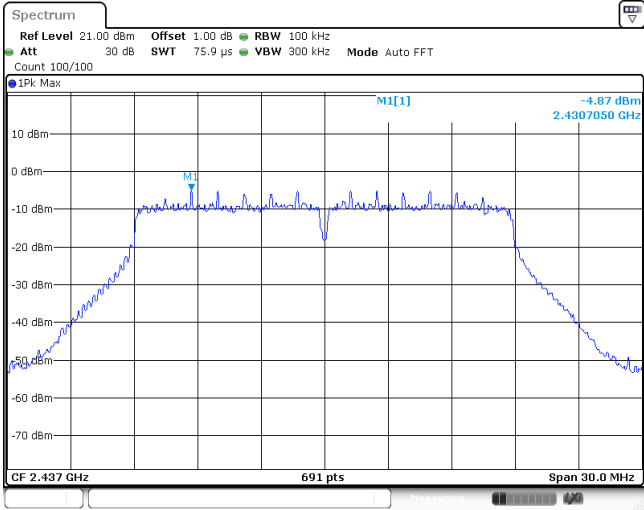
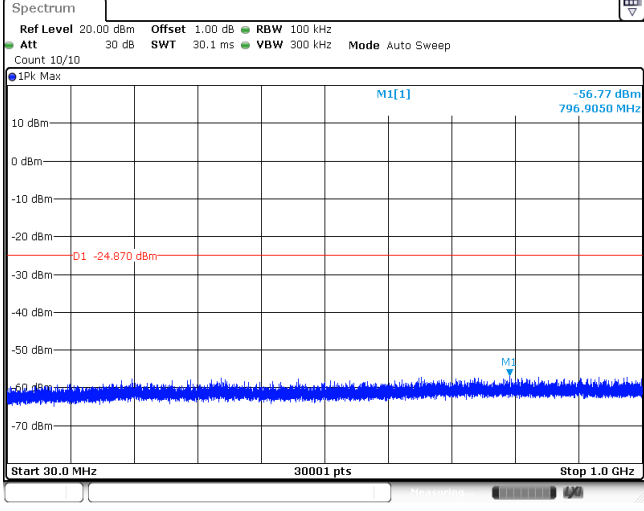
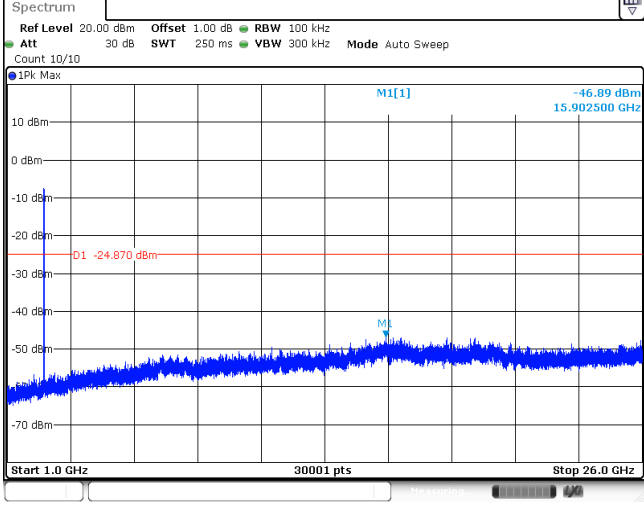
<p>Reference level CH06</p>	
<p>CH06</p>	
<p>CH06</p>	

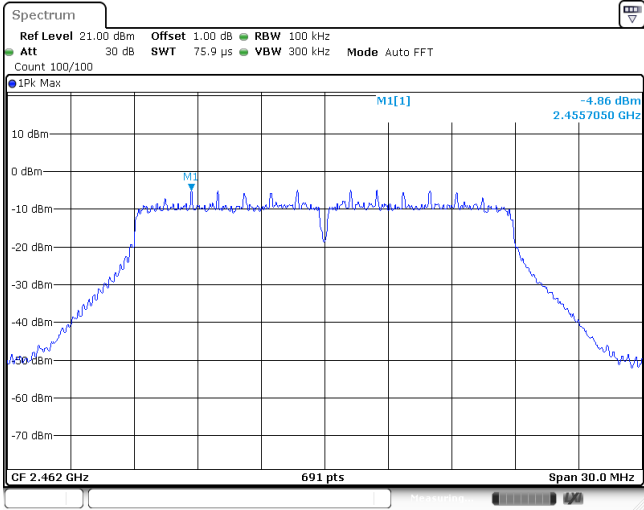
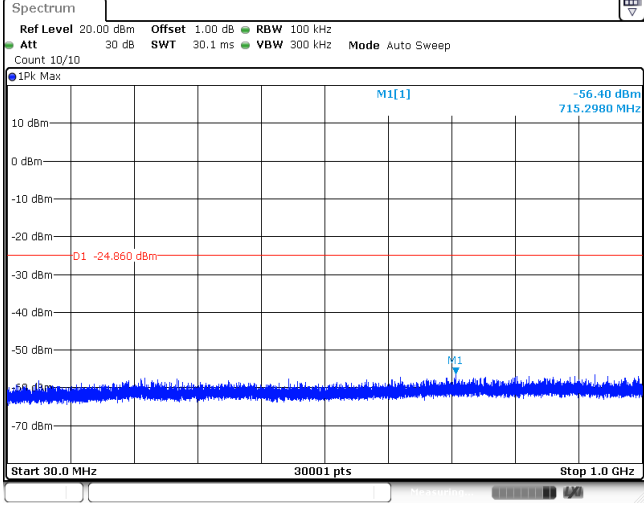
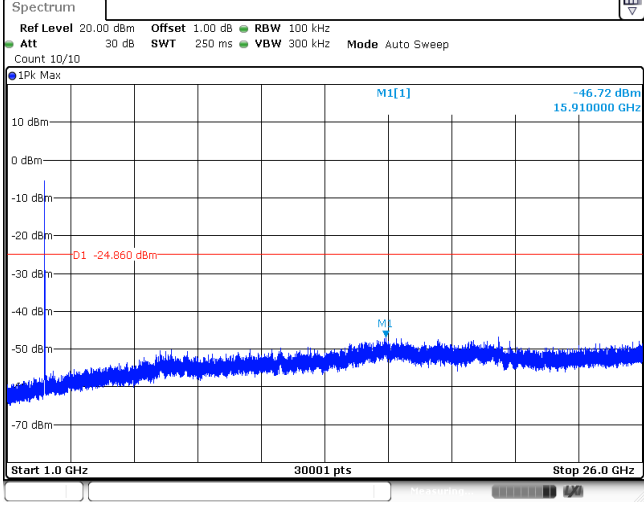
<p>Reference level CH11</p>	
<p>CH11</p>	
<p>CH11</p>	

Test Item:	SE	802.11 n(HT40)	Antenna 2
Reference level CH03			
CH03			
CH03			

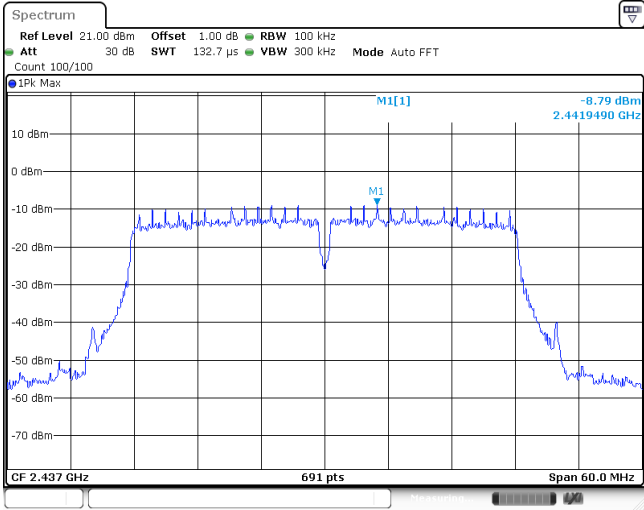
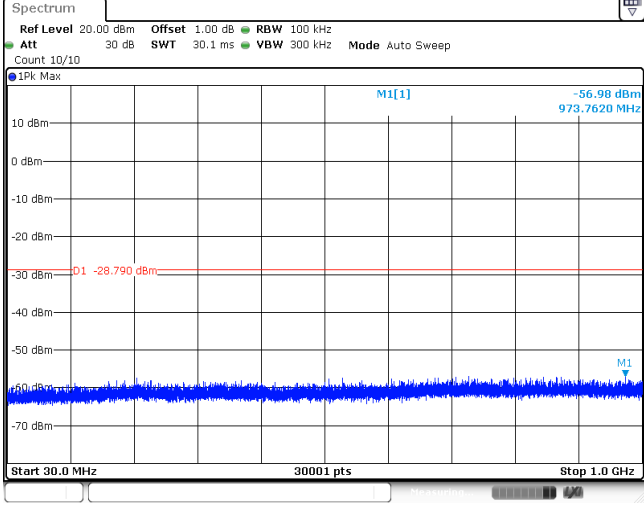
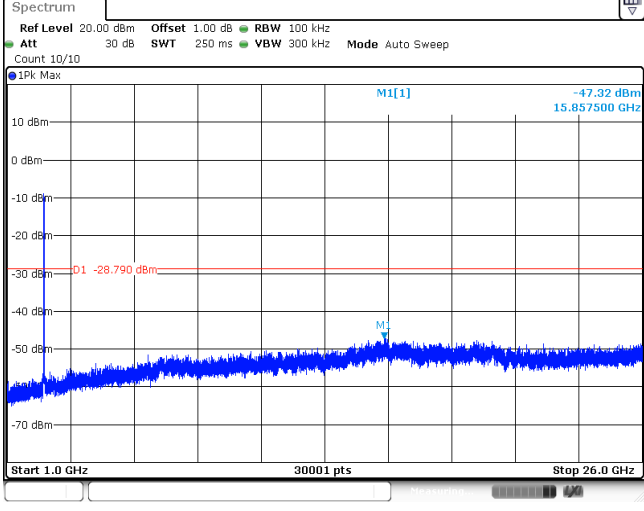
<p>Reference level CH06</p>	
<p>CH06</p>	
	

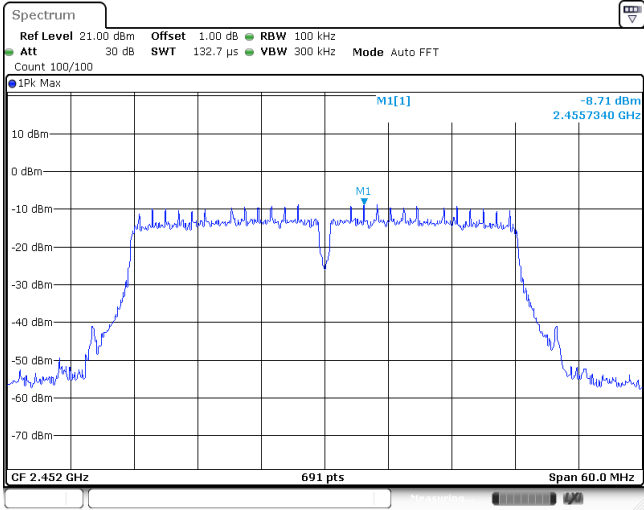
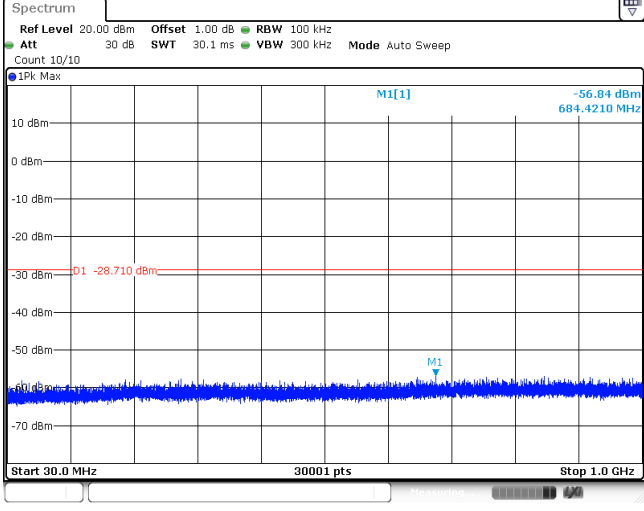
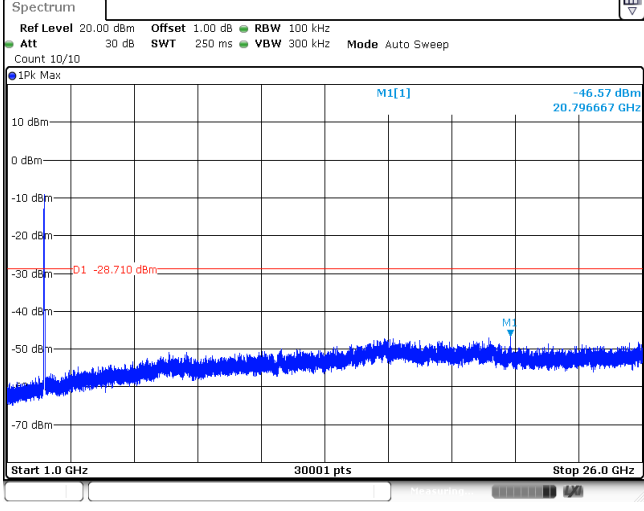
<p>Reference level CH09</p>	
<p>CH09</p>	
	

5.8. Spurious Emissions (Radiated)

LIMIT

FCC CFR Title 47 Part 15 Subpart C Section 15.209

Frequency	Limit (dBuV/m @3m)	Value
30MHz-88MHz	40.00	Quasi-peak
88MHz-216MHz	43.50	Quasi-peak
216MHz-960MHz	46.00	Quasi-peak
960MHz-1GHz	54.00	Quasi-peak
Above 1GHz	54.00	Average
	74.00	Peak

TEST CONFIGURATION

➤ 9kHz ~30MHz

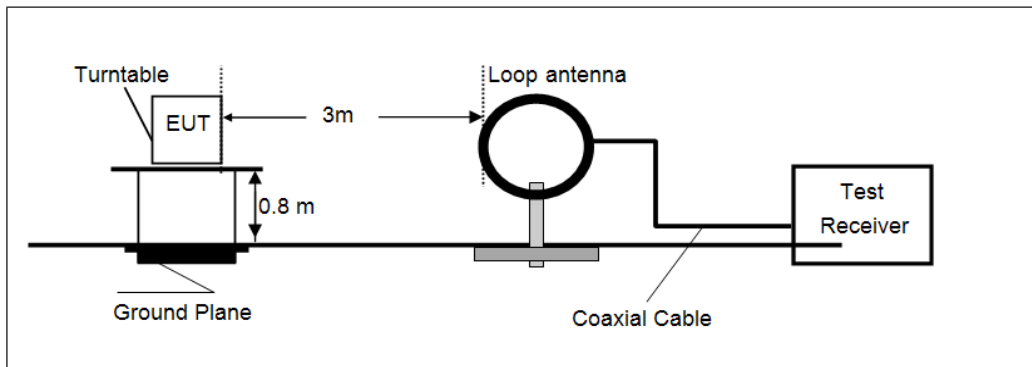

➤ 30MHz ~ 1GHz

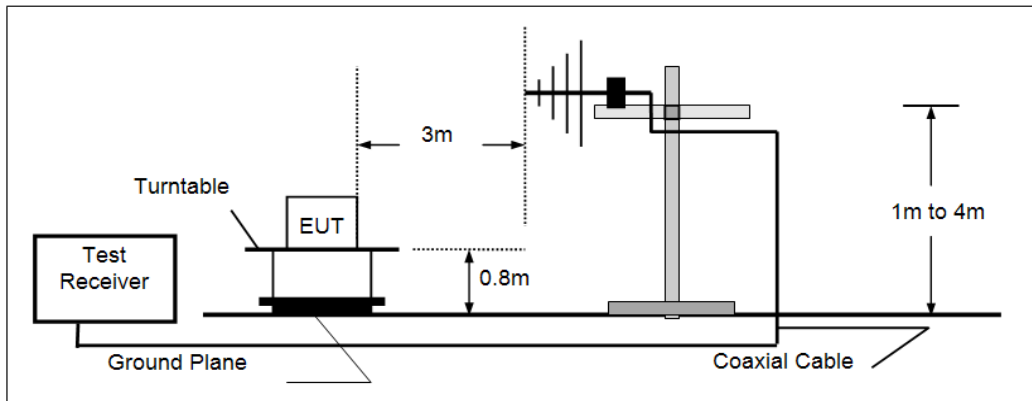

➤ Above 1GHz

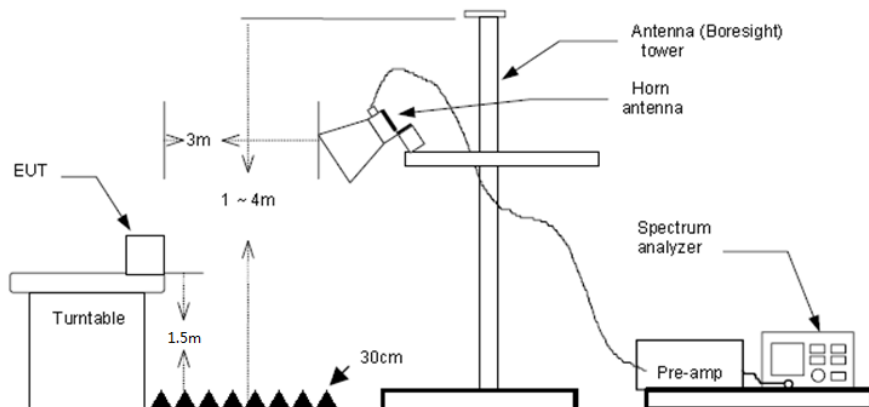

TEST PROCEDURE

1. The EUT was tested according to ANSI C63.10:2013 for compliance to FCC 47CFR 15.247 requirements.
2. The EUT is placed on a turn table which is 0.8 meter above ground. The turn table is rotated 360 degrees to determine the position of the maximum emission level.
3. The EUT was positioned such that the distance from antenna to the EUT was 3 meters.
4. The antenna is scanned from 1 meter to 4 meters to find out the maximum emission level. This is repeated for both horizontal and vertical polarization of the antenna.
5. Use the following spectrum analyzer settings
 - (1) Span shall wide enough to fully capture the emission being measured;
 - (2) Below 1GHz, RBW=120kHz, VBW=300kHz, Sweep=auto, Detector function=peak, Trace=max hold;
If the emission level of the EUT measured by the peak detector is 3 dB lower than the applicable limit, the peak emission level will be reported. Otherwise, the emission measurement will be repeated using the quasi-peak detector and reported.
 - (3) Above 1GHz, RBW=1MHz, VBW=3MHz PEAK detector for Peak value.
RBW=1MHz, VBW=3MHz RMS detector for Average value.

TEST MODE:

Please refer to the clause 3.3

TEST RESULTS

Passed **Not Applicable**

Note:

- 1) Final Level =Receiver Read level + Antenna Factor + Cable Loss – Preamplifier Factor
- 2) The emission levels of other frequencies are very lower than the limit and not show in test report.

➤ **9kHz ~ 30MHz**

The EUT was pre-scanned the frequency band (9kHz~30MHz), found the radiated level lower than the limit, so don't show on the report.

➤ **30MHz ~1000MHz**

Have pre-scan all modulation mode, found the 802.11b mode CH01 which it was worst case, so only the worst case's data on the test report.

30MHz ~ 1GHz

Polarization: Vertical

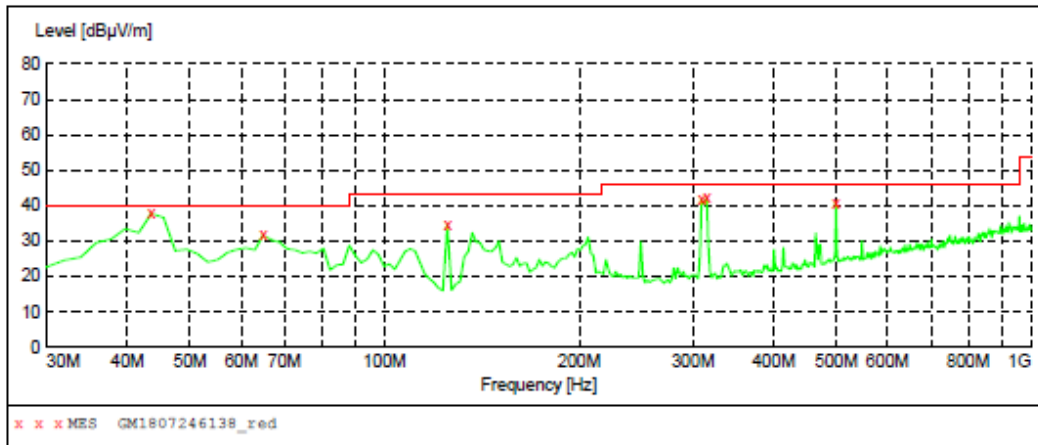

MEASUREMENT RESULT: "GM1807246138_red"

7/23/2018 9:15PM

Frequency MHz	Level dBµV/m	Transd dB	Limit dBµV/m	Margin dB	Det.	Height cm	Azimuth deg	Polarization
43.580000	37.70	-9.1	40.0	2.3	QP	100.0	213.00	VERTICAL
64.920000	31.60	-11.4	40.0	8.4	QP	100.0	121.00	VERTICAL
125.060000	34.60	-12.9	43.5	8.9	QP	100.0	69.00	VERTICAL
309.360000	41.80	-7.1	46.0	4.2	QP	100.0	348.00	VERTICAL
315.180000	42.10	-6.9	46.0	3.9	QP	100.0	321.00	VERTICAL
499.480000	40.60	-1.8	46.0	5.4	QP	100.0	161.00	VERTICAL

Polarization: Horizontal

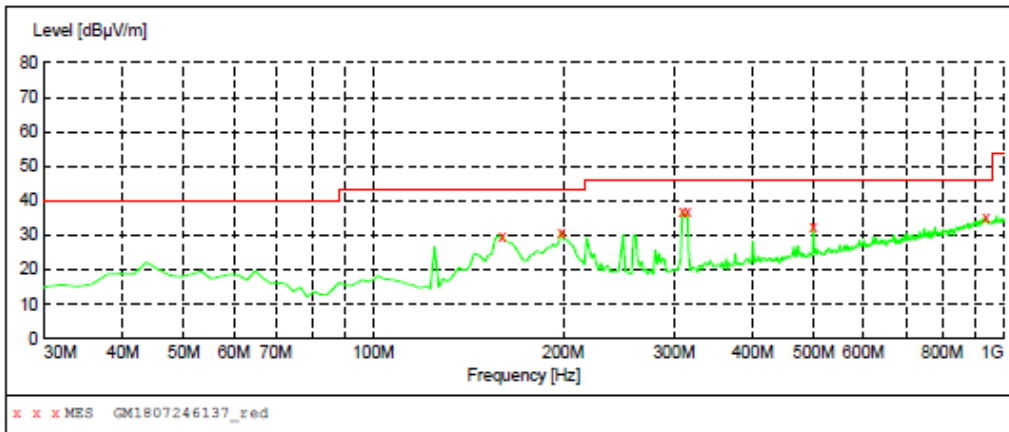

MEASUREMENT RESULT: "GM1807246137_red"

7/23/2018 9:13PM

Frequency MHz	Level dBµV/m	Transd dB	Limit dBµV/m	Margin dB	Det.	Height cm	Azimuth deg	Polarization
159.980000	29.70	-13.4	43.5	13.8	QP	300.0	162.00	HORIZONTAL
198.780000	30.90	-9.8	43.5	12.6	QP	300.0	349.00	HORIZONTAL
309.360000	36.80	-7.1	46.0	9.2	QP	100.0	360.00	HORIZONTAL
315.180000	36.60	-6.9	46.0	9.4	QP	100.0	187.00	HORIZONTAL
499.480000	32.20	-1.8	46.0	13.8	QP	100.0	187.00	HORIZONTAL
937.920000	35.00	7.1	46.0	11.0	QP	300.0	80.00	HORIZONTAL

1 GHz~25GHz

802.11b					CH01				
Frequency (MHz)	Read Level (dBuV)	Antenna Factor (dB/m)	Cable Loss (dB)	Preamplifier Factor (dB)	Level (dBuV/m)	Limit Line (dBuV/m)	Over Limit (dB)	Polarization	Test value
2995.54	51.13	28.60	7.48	37.58	49.63	74.00	-24.37	Vertical	Peak
4821.76	39.61	31.56	9.55	35.69	45.03	74.00	-28.97	Vertical	Peak
4996.69	39.18	31.50	9.67	35.39	44.96	74.00	-29.04	Vertical	Peak
7245.80	28.99	36.25	11.91	33.45	43.70	54.00	-10.3	Vertical	Average
7245.81	40.31	36.25	11.91	33.45	55.02	74.00	-18.98	Vertical	Peak
1185.96	35.83	26.19	4.63	37.23	29.42	74.00	-44.58	Horizontal	Peak
2995.54	46.59	28.60	7.48	37.58	45.09	74.00	-28.91	Horizontal	Peak
4821.76	41.88	31.56	9.55	35.69	47.30	74.00	-26.70	Horizontal	Peak
7245.81	36.90	36.25	11.91	33.45	51.61	74.00	-22.39	Horizontal	Peak

802.11b					CH06				
Frequency (MHz)	Read Level (dBuV)	Antenna Factor (dB/m)	Cable Loss (dB)	Preamplifier Factor (dB)	Level (dBuV/m)	Limit Line (dBuV/m)	Over Limit (dB)	Polarization	Test value
2995.54	47.49	28.60	7.48	37.58	45.99	74.00	-28.01	Vertical	Peak
4871.10	38.75	31.46	9.59	35.61	44.19	74.00	-29.81	Vertical	Peak
4996.69	40.87	31.50	9.67	35.39	46.65	74.00	-27.35	Vertical	Peak
7319.96	29.46	36.30	11.99	33.32	44.43	54.00	-9.57	Vertical	Average
7319.96	40.44	36.30	11.99	33.32	55.41	74.00	-18.59	Vertical	Peak
1182.94	36.23	26.17	4.62	37.23	29.79	74.00	-44.21	Horizontal	Peak
2995.54	43.30	28.60	7.48	37.58	41.80	74.00	-32.20	Horizontal	Peak
4871.10	41.78	31.46	9.59	35.61	47.22	74.00	-26.78	Horizontal	Peak
7319.96	38.58	36.30	11.99	33.32	53.55	74.00	-20.45	Horizontal	Peak

802.11b					CH11				
Frequency (MHz)	Read Level (dBuV)	Antenna Factor (dB/m)	Cable Loss (dB)	Preamplifier Factor (dB)	Level (dBuV/m)	Limit Line (dBuV/m)	Over Limit (dB)	Polarization	Test value
2995.54	49.78	28.60	7.48	37.58	48.28	74.00	-25.72	Vertical	Peak
4920.96	37.01	31.42	9.62	35.52	42.53	74.00	-31.47	Vertical	Peak
4996.69	40.07	31.50	9.67	35.39	45.85	74.00	-28.15	Vertical	Peak
7394.88	28.92	36.30	12.06	33.20	44.08	54.00	-9.92	Vertical	Average
7394.88	39.56	36.30	12.06	33.20	54.72	74.00	-19.28	Vertical	Peak
1768.62	34.82	25.34	5.90	37.37	28.69	74.00	-45.31	Horizontal	Peak
2987.92	46.15	28.59	7.47	37.58	44.63	74.00	-29.37	Horizontal	Peak
4920.96	39.55	31.42	9.62	35.52	45.07	74.00	-28.93	Horizontal	Peak
7394.88	37.98	36.30	12.06	33.20	53.14	74.00	-20.86	Horizontal	Peak

Remark:

1. Final Level = Receiver Read level + Antenna Factor + Cable Loss – Preamplifier Factor
2. The peak level is lower than average limit(54 dBuV/m), this data is the too weak instrument of signal is unable to test.
3. The emission levels of other frequencies are very lower than the limit and not show in test report.

802.11g					CH01				
Frequency (MHz)	Read Level (dBuV)	Antenna Factor (dB/m)	Cable Loss (dB)	Preamp Factor (dB)	Level (dBuV/m)	Limit Line (dBuV/m)	Over Limit (dB)	Polarization	Test value
2995.54	51.55	28.60	7.48	37.58	50.05	74.00	-23.95	Vertical	Peak
3993.90	37.49	29.70	8.77	36.76	39.20	74.00	-34.80	Vertical	Peak
4996.69	37.41	31.50	9.67	35.39	43.19	74.00	-30.81	Vertical	Peak
7245.81	35.21	36.25	11.91	33.45	49.92	74.00	-24.08	Vertical	Peak
1188.98	36.77	26.22	4.64	37.23	30.40	74.00	-43.60	Horizontal	Peak
2995.54	45.05	28.60	7.48	37.58	43.55	74.00	-30.45	Horizontal	Peak
4996.69	34.30	31.50	9.67	35.39	40.08	74.00	-33.92	Horizontal	Peak
7245.81	34.44	36.25	11.91	33.45	49.15	74.00	-24.85	Horizontal	Peak

802.11g					CH06				
Frequency (MHz)	Read Level (dBuV)	Antenna Factor (dB/m)	Cable Loss (dB)	Preamp Factor (dB)	Level (dBuV/m)	Limit Line (dBuV/m)	Over Limit (dB)	Polarization	Test value
2987.92	50.46	28.59	7.47	37.58	48.94	74.00	-25.06	Vertical	Peak
3854.08	35.19	29.65	8.58	36.87	36.55	74.00	-37.45	Vertical	Peak
4996.69	40.17	31.50	9.67	35.39	45.95	74.00	-28.05	Vertical	Peak
7319.96	35.32	36.30	11.99	33.32	50.29	74.00	-23.71	Vertical	Peak
2987.92	46.45	28.59	7.47	37.58	44.93	74.00	-29.07	Horizontal	Peak
3795.66	35.11	29.59	8.50	36.91	36.29	74.00	-37.71	Horizontal	Peak
4883.52	33.83	31.43	9.59	35.58	39.27	74.00	-34.73	Horizontal	Peak
7319.96	35.02	36.30	11.99	33.32	49.99	74.00	-24.01	Horizontal	Peak

802.11g					CH11				
Frequency (MHz)	Read Level (dBuV)	Antenna Factor (dB/m)	Cable Loss (dB)	Preamp Factor (dB)	Level (dBuV/m)	Limit Line (dBuV/m)	Over Limit (dB)	Polarization	Test value
1179.94	35.82	26.14	4.61	37.24	29.33	74.00	-44.67	Vertical	Peak
2987.92	51.57	28.59	7.47	37.58	50.05	74.00	-23.95	Vertical	Peak
3993.90	39.27	29.70	8.77	36.76	40.98	74.00	-33.02	Vertical	Peak
7394.88	35.69	36.30	12.06	33.20	50.85	74.00	-23.15	Vertical	Peak
2987.92	42.89	28.59	7.47	37.58	41.37	74.00	-32.63	Horizontal	Peak
4676.70	33.51	31.13	9.49	35.96	38.17	74.00	-35.83	Horizontal	Peak
5762.24	33.07	31.91	10.53	34.28	41.23	74.00	-32.77	Horizontal	Peak
7394.88	33.64	36.30	12.06	33.20	48.80	74.00	-25.20	Horizontal	Peak

Remark:

1. Final Level = Receiver Read level + Antenna Factor + Cable Loss – Preamplifier Factor
2. The peak level is lower than average limit(54 dBuV/m), this data is the too weak instrument of signal is unable to test.
3. The emission levels of other frequencies are very lower than the limit and not show in test report.

802.11n(HT20)					CH01				
Frequency (MHz)	Read Level (dBuV)	Antenna Factor (dB/m)	Cable Loss (dB)	Preamp Factor (dB)	Level (dBuV/m)	Limit Line (dBuV/m)	Over Limit (dB)	Polarization	Test value
1150.28	36.55	25.91	4.55	37.25	29.76	74.00	-44.24	Vertical	Peak
2995.54	49.05	28.60	7.48	37.58	47.55	74.00	-26.45	Vertical	Peak
4996.69	37.82	31.50	9.67	35.39	43.60	74.00	-30.40	Vertical	Peak
7227.39	35.95	36.23	11.89	33.48	50.59	74.00	-23.41	Vertical	Peak
1192.01	35.68	26.24	4.64	37.23	29.33	74.00	-44.67	Horizontal	Peak
2995.54	42.34	28.60	7.48	37.58	40.84	74.00	-33.16	Horizontal	Peak
4996.69	35.03	31.50	9.67	35.39	40.81	74.00	-33.19	Horizontal	Peak
7245.81	34.18	36.25	11.91	33.45	48.89	74.00	-25.11	Horizontal	Peak

802.11n(HT20)					CH06				
Frequency (MHz)	Read Level (dBuV)	Antenna Factor (dB/m)	Cable Loss (dB)	Preamp Factor (dB)	Level (dBuV/m)	Limit Line (dBuV/m)	Over Limit (dB)	Polarization	Test value
2995.54	49.67	28.60	7.48	37.58	48.17	74.00	-25.83	Vertical	Peak
3993.90	36.19	29.70	8.77	36.76	37.90	74.00	-36.10	Vertical	Peak
4983.99	40.74	31.48	9.66	35.41	46.47	74.00	-27.53	Vertical	Peak
7319.96	34.34	36.30	11.99	33.32	49.31	74.00	-24.69	Vertical	Peak
1179.94	36.09	26.14	4.61	37.24	29.60	74.00	-44.40	Horizontal	Peak
2995.54	43.94	28.60	7.48	37.58	42.44	74.00	-31.56	Horizontal	Peak
4996.69	34.69	31.50	9.67	35.39	40.47	74.00	-33.53	Horizontal	Peak
7319.96	32.43	36.30	11.99	33.32	47.40	74.00	-26.60	Horizontal	Peak

802.11n(HT20)					CH11				
Frequency (MHz)	Read Level (dBuV)	Antenna Factor (dB/m)	Cable Loss (dB)	Preamp Factor (dB)	Level (dBuV/m)	Limit Line (dBuV/m)	Over Limit (dB)	Polarization	Test value
1188.98	36.13	26.22	4.64	37.23	29.76	74.00	-44.24	Vertical	Peak
2987.92	51.75	28.59	7.47	37.58	50.23	74.00	-23.77	Vertical	Peak
4996.69	35.01	31.50	9.67	35.39	40.79	74.00	-33.21	Vertical	Peak
7394.88	35.03	36.30	12.06	33.20	50.19	74.00	-23.81	Vertical	Peak
1159.10	35.98	25.98	4.57	37.25	29.28	74.00	-44.72	Horizontal	Peak
2987.92	43.13	28.59	7.47	37.58	41.61	74.00	-32.39	Horizontal	Peak
4983.99	33.69	31.48	9.66	35.41	39.42	74.00	-34.58	Horizontal	Peak
6494.56	32.11	33.96	11.16	33.63	43.60	74.00	-30.40	Horizontal	Peak

Remark:

- Final Level = Receiver Read level + Antenna Factor + Cable Loss – Preamplifier Factor
- The peak level is lower than average limit(54 dBuV/m), this data is the too weak instrument of signal is unable to test.
- The emission levels of other frequencies are very lower than the limit and not show in test report.

802.11n(HT40)					CH03				
Frequency (MHz)	Read Level (dBuV)	Antenna Factor (dB/m)	Cable Loss (dB)	Preamp Factor (dB)	Level (dBuV/m)	Limit Line (dBuV/m)	Over Limit (dB)	Polarization	Test value
1182.94	35.88	26.17	4.62	37.23	29.44	74.00	-44.56	Vertical	Peak
2995.54	51.55	28.60	7.48	37.58	50.05	74.00	-23.95	Vertical	Peak
4996.69	42.04	31.50	9.67	35.39	47.82	74.00	-26.18	Vertical	Peak
8042.90	32.11	37.06	12.40	33.06	48.51	74.00	-25.49	Vertical	Peak
1198.10	35.62	26.29	4.66	37.23	29.34	74.00	-44.66	Horizontal	Peak
2995.54	44.85	28.60	7.48	37.58	43.35	74.00	-30.65	Horizontal	Peak
4809.50	32.94	31.58	9.55	35.72	38.35	74.00	-35.65	Horizontal	Peak
6662.01	32.02	34.20	11.43	33.71	43.94	74.00	-30.06	Horizontal	Peak

802.11n(HT40)					CH06				
Frequency (MHz)	Read Level (dBuV)	Antenna Factor (dB/m)	Cable Loss (dB)	Preamp Factor (dB)	Level (dBuV/m)	Limit Line (dBuV/m)	Over Limit (dB)	Polarization	Test value
1764.12	41.34	25.33	5.89	37.37	35.19	74.00	-38.81	Vertical	Peak
2987.92	52.34	28.59	7.47	37.58	50.82	74.00	-23.18	Vertical	Peak
4983.99	36.71	31.48	9.66	35.41	42.44	74.00	-31.56	Vertical	Peak
7508.69	32.36	36.11	12.42	33.02	47.87	74.00	-26.13	Vertical	Peak
1773.13	36.80	25.35	5.91	37.38	30.68	74.00	-43.32	Horizontal	Peak
2995.54	46.28	28.60	7.48	37.58	44.78	74.00	-29.22	Horizontal	Peak
4785.08	33.00	31.54	9.53	35.76	38.31	74.00	-35.69	Horizontal	Peak
7527.83	31.95	36.13	12.49	33.02	47.55	74.00	-26.45	Horizontal	Peak

802.11n(HT40)					CH09				
Frequency (MHz)	Read Level (dBuV)	Antenna Factor (dB/m)	Cable Loss (dB)	Preamp Factor (dB)	Level (dBuV/m)	Limit Line (dBuV/m)	Over Limit (dB)	Polarization	Test value
1219.64	35.04	26.28	4.69	37.21	28.80	74.00	-45.20	Vertical	Peak
2995.54	50.88	28.60	7.48	37.58	49.38	74.00	-24.62	Vertical	Peak
3983.75	35.15	29.70	8.76	36.77	36.84	74.00	-37.16	Vertical	Peak
7376.08	32.41	36.30	12.04	33.23	47.52	74.00	-26.48	Vertical	Peak
1179.94	35.70	26.14	4.61	37.24	29.21	74.00	-44.79	Horizontal	Peak
2987.92	45.88	28.59	7.47	37.58	44.36	74.00	-29.64	Horizontal	Peak
5603.13	32.80	31.79	10.28	34.36	40.51	74.00	-33.49	Horizontal	Peak
7527.83	32.21	36.13	12.49	33.02	47.81	74.00	-26.19	Horizontal	Peak

Remark:

1. Final Level = Receiver Read level + Antenna Factor + Cable Loss – Preamplifier Factor
2. The peak level is lower than average limit(54 dBuV/m), this data is the too weak instrument of signal is unable to test.
3. The emission levels of other frequencies are very lower than the limit and not show in test report.

.....End of Report.....