FCC Part 90 Rules Test Report

Report No.: AGC00589170705FE10

FCC ID : T4KD868SVHF
PRODUCT DESIGNATION : DMR Digital Radio
BRAND NAME : N/A
MODEL NAME : D868S
CLIENT : Qixiang Electron Science & Technology Co., Ltd
DATE OF ISSUE : Jul. 03,2017
STANDARD(S) : FCC Part 90 Rules
: FCC Part 22 Rules
REPORT VERSION : V 1.0

Attestation of Global Compliance (Shenzhen) Co., Ltd



CAUTION:

This report shall not be reproduced except in full without the written permission of the test laboratory and shall not be quoted out of context.



Report Revise Record

Report Version	Revise Time	Issued Date	Valid Version	Notes
V1.0	/	Jul. 03,2017	Valid	Original Report

VERIFICATION OF COMPLIANCE

Applicant:	Qixiang Electron Science & Technology Co., Ltd
	Qixiang Building, Tangxi Industrial Zone, Luojiang ,Quanzhou, Fujian, 362011 China
Manufacturer:	Qixiang Electron Science & Technology Co., Ltd
	Qixiang Building, Tangxi Industrial Zone, Luojiang ,Quanzhou, Fujian, 362011 China
Product Designation:	DMR Digital Radio
Brand Name:	N/A
Test Model	D868S
Date of Test:	Jun. 28,2017 to Jul. 03,2017

WE HEREBY CERTIFY THAT:

The above equipment was tested by Dongguan Precise Testing Service Co., Ltd. The data evaluation, test procedures, and equipment configurations shown in this report were made in accordance with the procedures given in TIA/EIA 603. The sample tested as described in this report is in compliance with the FCC Rules Part 90 and FCC Rules Part 22 requirements

The test results of this report relate only to the tested sample identified in this report.

Tested by



Steven Zhou(Zhou Pengyun) Jul. 03,2017

Reviewed by



Bart Xie(Xie Xiaobin) Jul. 03,2017

Approved by



Solger Zhang(Zhang Hongyi)
Authorized Officer Jul. 03,2017

TABLE OF CONTENTS

1. GENERAL INFORMATION 6

1.1 PRODUCT DESCRIPTION 6

1.2 RELATED SUBMITTAL(S) / GRANT (S) 8

1.3 TEST METHODOLOGY 8

1.4 TEST FACILITY 8

1.5 SPECIAL ACCESSORIES..... 8

1.6 EQUIPMENT MODIFICATIONS..... 8

2. SYSTEM TEST CONFIGURATION 9

2.1 EUT CONFIGURATION 9

2.2 EUT EXERCISE 9

2.3 GENERAL TECHNICAL REQUIREMENTS..... 9

2.4 CONFIGURATION OF TESTED SYSTEM 10

3. SUMMARY OF TEST RESULTS 10

5. FREQUENCY TOLERANCE 13

5.1 PROVISIONS APPLICABLE 13

5.2 MEASUREMENT PROCEDURE 13

5.3 TEST SETUP BLOCK DIAGRAM 14

5.3 TEST RESULT 15

6. EMISSION BANDWIDTH 37

6.1 PROVISIONS APPLICABLE 37

6.2 MEASUREMENT PROCEDURE 37

6.3 TEST SETUP BLOCK DIAGRAM 37

6.4 MEASUREMENT RESULT 38

7. UNWANTED RADIATION..... 54

7.1 PROVISIONS APPLICABLE 54

7.2 MEASUREMENT PROCEDURE 54

7.3 TEST SETUP BLOCK DIAGRAM 55

7.4 MEASUREMENT RESULTS..... 56

7.5 EMISSION MASK PLOT 58

8. MODULATION CHARACTERISTICS 67

8.1 PROVISIONS APPLICABLE 67

8.2 MEASUREMENT METHOD 67

8.3 MEASUREMENT RESULT 68

9. MAXIMUM TRANSMITTER POWER (CONDUCTED OUTPUT POWER)..... 74

9.1 PROVISIONS APPLICABLE	74
9.2 TEST PROCEDURE.....	74
9.3 TEST CONFIGURATION.....	74
9.4 TEST RESULT.....	76
9.5 CONDUCT SPURIOUS PLOT	85
10. TRANSMITTER FREQUENCY BEHAVIOR.....	102
10.1 PROVISIONS APPLICABLE	102
10.2 TEST METHOD	102
10.3 DESCRIBE LIMIT LINE OF TRANSMITTER FREQUENCY BEHAVIOR.....	103
10.4 MEASURE RESULT	104
11. AUDIO LOW PASS FILTER RESPONSE	106
11.1 LIMITS.....	106
11.2. METHOD OF MEASUREMENTS.....	106
11.3 TEST DATA.....	107
APPENDIX I: PHOTOGRAPHS OF SETUP	109
APPENDIX II: EXTERNAL VIEW OF EUT	110

1. GENERAL INFORMATION

1.1 PRODUCT DESCRIPTION

The EUT is a **DIGITAL/ANALOG RADIO** designed for voice/data communication. It is designed by way of utilizing the FM/4FSK modulation achieves the system operating.

A major technical description of EUT is described as following:

Communication Type	Voice / Data
Hardware Version	V3.0
Software Version	V1.0
Modulation	FM/4FSK
Emission Type	11K0F3E, 7K60FXD, 7K60FXW
Emission Bandwidth	Analog:10.18KHz(10W),10.16KHz(4.5W) ---VHF-12.5KHz Analog:10.19KHz(2.5W),10.17KHz(1W) ---VHF-12.5KHz Digital: 9.680KHz(10W), 9.425 KHz(4.5W) ---VHF-12.5KHz Digital:9.8.927KHz(2.5W),8.865KHz(1W) ---VHF-12.5KHz
Peak Frequency Deviation	1.95KHz
Audio Frequency Response	10.88 dB
Maximum Transmitter Power	Analog:39.92 dBm(10W), 36.41dBm (4.5W) ---VHF-12.5KHz Analog:33.83 dBm(2.5W), 29.82dBm (1W) ---VHF-12.5KHz Digital:38.92 dBm(10W), 36.49dBm (4.5W) ---VHF-12.5KHz Digital:33.83 dBm(2.5W), 29.92dBm (1W) ---VHF-12.5KHz
Output power Modification	10W/4.5W/2.5W/1W (It was fixed by the manufacturer, any individual can't arbitrarily change it.)
Data Rate	9600bps/12.5KHz(Channel Spacing)
Antenna Designation	Detachable
Antenna Gain	2.15 dBi
Power Supply	DC 7.4V, 2000mAh (by battery)
Adapter Parameter	INPUT: AC 100V-240V , 50/60Hz , 0.3A OUTPUT: DC 12V, 1A
Limiting Voltage	DC 6.00V-8.51V
Operation Frequency Range and Channel	Frequency Range: 136 MHz to 174 MHz Channel Separation: 12.5KHz (Analog), 12.5KHz(Digital)
	Bottom Channel: 136.025MHz Middle Channel:151.85MHz Middle Channel:155.025MHz Middle Channel:161.61MHz Top Channel: 173.975MHz
Frequency Tolerance	1.368ppm

Frequency Range (MHz)	Rated Transmit Power(W)(Conducted)	Transmit Mode/Emission Designator
136-174	10W/4.5W/2.5W/1W	11K0F3E(Analog Voice;NB)
136-174	10W/4.5W/2.5W/1W	7K60FXD/7K60FXW(9600Data/Digital Voice NB)

Channel No. (6.25KHz)	Channel No. (12.5KHz)	12.5KHz Channel Spaced 400MHz Band Plan(MHz)
1	1-2	136.025
2		
3	3-4	155.025
4		
5	5-6	173.975
6		

FCC Rules and Regulations Part 2.202: Necessary Bandwidth and Emission Bandwidth

Voice –FM Analog (12.5KHz)

Calculation:

Max modulation (M) in kHz : 3.0

Max deviation(D) in kHz:2.5

Constant factor (K): 1(assumed)

$B_n = 2XM + 2XDK = 11.0$ KHz

Emission designator: 11K0F3E

9600 Digital Voice/data (12.5KHz)

Calculation:

Data rate in bps(R)=9600

Deviation Peak deviation of carrier(D)=2359.585

Constant factor (K): 1 (default)

$B_n = 3.86D + 1.27RK = 3.86(2359.585) + 0.27(9600)(1) = 11.7$ KHz

Emission designator: 11K0FXD

1.2 RELATED SUBMITTAL(S) / GRANT (S)

This submittal(s) (test report) is intended for **FCC ID:** T4KD868SVHF, filing to comply with Part 2, Part 22, and Part 90 of the Federal Communication Commission rules.

1.3 TEST METHODOLOGY

The radiated emission testing was performed according to the procedures of TIA/EIA 603 and FCC CFR 47 Rules of 2.1046, 2.1047, 2.1049, 2.1051, 2.1053, 2.1055, 2.1057.

1.4 TEST FACILITY

Site	Dongguan Precise Testing Service Co., Ltd.
Location	Building D, Baoding Technology Park, Guangming Road2, Dongcheng District, Dongguan, Guangdong, China.
Description	The test site is constructed and calibrated to meet the FCC requirements in documents TIA/EIA 603
FCC Registration No.	371540

1.5 SPECIAL ACCESSORIES

Not available for this EUT intended for grant.

1.6 EQUIPMENT MODIFICATIONS

Not available for this EUT intended for grant.

2. SYSTEM TEST CONFIGURATION

2.1 EUT CONFIGURATION

The EUT configuration for testing is installed on RF field strength measurement to meet the Commission's requirement and operating in a manner which intends to maximize its emission characteristics in a continuous normal application.

2.2 EUT EXERCISE

The Transmitter was operated in the normal operating mode. The TX frequency was fixed which was for the purpose of the measurements.

2.3 GENERAL TECHNICAL REQUIREMENTS

For FCC Part 90& Part 22 requirements:

- (1). Section 90.205 & 22.565: RF Output Power
- (2). Section 90.207: Modulation Characteristic
- (3). Section 90.209 & 22.359: Occupied Bandwidth
- (4). Section 90.210 & 22.359: Emission Mask
- (5). Section 90.213 & 22.355: Frequency Tolerance
- (6). Section 90.214: Transient Frequency Behavior

2.4 CONFIGURATION OF TESTED SYSTEM

Fig. 2-1 Configuration of Tested System



Table 2-1 Equipment Used in Tested System

Item	Equipment	Model No.	Identifier	Note
1	DMR Digital Radio	D868S	FCC ID: T4KD868SVHF	EUT

3. SUMMARY OF TEST RESULTS

FCC Rules	Description Of Test	Result
§90.205 & 22.565	Maximum Transmitter Power	Compliant
§90.207	Modulation Characteristic	Compliant
§90.209& 22.359	Occupied Bandwidth	Compliant
§90.210& 22.359	Emission Mask	Compliant
§90.213& 22.355	Frequency Tolerance	Compliant
§90.214	Transient Frequency Behavior	Compliant

LIST OF EQUIPMENTS USED

NAME OF EQUIPMENT	MANUFACTURER	MODEL	SERIAL NO.	Cal. Date	Cal. Due
CLIMATE CHAMBER	EXPERY	TN-400	TN2007SR038	2017.06.20	2018.06.19
ATTENUATOR	WEINSCHTEL CORP	58-30-33	ML030	2017.06.20	2018.06.19
DC POWER SUPPLY	ZHAOXIN	RXN-605D	N/A	2017.06.20	2018.06.19
MODULATION ANALYZER	HP	8920B	3104A03367	2017.06.20	2018.06.19
SIGNAL GENERATOR	AGILENT	E4421B	122501288	2017.07.02	2018.07.01
SIGNAL GENERATOR	R&S	SMT03	A0304261	2017.07.02	2018.07.01
EMI Test Receiver	Rohde & Schwarz	ESCI	101417	2017.07.02	2018.07.01
Trilog Broadband Antenna	SCHWARZBECK	VULB9160	9160-3355	2017.07.02	2018.07.01
Substitution Antenna	SCHWARZBECK	VULB9160	9168-494	2017.07.02	2018.07.01
Signal Amplifier	SCHWARZBECK	BBV 9475	9745-0013	2017.07.02	2018.07.01
RF Cable	SCHWARZBECK	AK9515E	96221	2017.07.02	2018.07.01
3m Anechoic Chamber	CHENGYU	966	PTS-001	2017.06.02	2018.06.01
MULTI-DEVICE Positioning Controller	Max-Full	MF-7802	MF780208339	N/A	N/A
Active loop antenna (9K-30MHz)	Schwarzbeck	FMZB1519	1519-038	2017.06.02	2018.06.01
Spectrum analyzer	Agilent	E4407B	MY46185649	2017.06.02	2018.06.01
Double-Ridged Waveguide Horn	ETS LINDGREN	3117	00034609	2017.06.02	2018.06.01
Substitution ANTENNA	EM	EM-AH-10180	67	2017.06.02	2018.06.01
Modulation Domain Analyzer	HP	53310A	3121A02467	2017.06.02	2018.06.01
EMI Test Receiver	Rohde & Schwarz	ESCI	101417	2017.06.02	2018.06.01
RF Cable	SCHWARZBECK	AK9515E	96222	2017.06.02	2018.06.01
Shielded Room	CHENGYU	843	PTS-002	2017.06.02	2018.06.01

Note: 8920B can generate audio modulation frequency.

4. DESCRIPTION OF TEST MODES

RF TEST MODES

The EUT (DMR Digital Radio) has been tested under normal operating condition. (The top channel, the middle channel and the bottom channel) are chosen for testing at each channel separation.

Analog:

No.	TEST MODES	CHANNEL SEPARATION
1	Low Channel	12.5 KHz
2	Middle Channel	12.5 KHz
3	High Channel	12.5 KHz

Digital:

No.	TEST MODES	CHANNEL SEPARATION
1	Low Channel	12.5 KHz
2	Middle Channel	12.5 KHz
3	High Channel	12.5 KHz

Note: Only the result of the worst case was recorded in the report.

5. FREQUENCY TOLERANCE

5.1 PROVISIONS APPLICABLE

- a). According to FCC §2.1055, § 22.355 and §90.213, the frequency stability shall be measured with variation of ambient temperature from -30°C to $+50^{\circ}\text{C}$ centigrade.
- b). According to FCC Part 2 Section 2.1055(d)(2), for battery powered equipment, the frequency stability shall be measured with reducing primary supply voltage to the battery operating end point, which is specified by the manufacturer.
- c). According to FCC Part 90 Section 90.213, the frequency tolerance must be maintained within 0.00025% for 12.5 KHz channel separation and 0.0001% for 6.25 KHz channel separation.

5.2 MEASUREMENT PROCEDURE

5.2.1 Frequency stability versus environmental temperature

1. Setup the configuration per figure 1 for frequencies measurement inside an environment chamber, Install new battery in the EUT.
2. Turn on EUT and set SA center frequency to the EUT radiated frequency. Set SA Resolution Bandwidth to 1KHz and Video Resolution Bandwidth to 1KHz and Frequency Span to 50KHz. Record this frequency as reference frequency.
3. Set the temperature of chamber to 50°C . Allow sufficient time (approximately 30 min) for the temperature of the chamber to stabilize. While maintaining a constant temperature inside the chamber, turn the EUT on and measure the EUT operating frequency.
4. Repeat step 2 with a 10°C decreased per stage until the lowest temperature -30°C is measured, record all measured frequencies on each temperature step.

5.2.2 Frequency stability versus input voltage

1. Setup the configuration per figure 1 for frequencies measured at temperature if it is within 15°C to 25°C . Otherwise, an environment chamber set for a temperature of 20°C shall be used. The EUT shall be powered by DC 7.4V.
2. Set SA center frequency to the EUT radiated frequency. Set SA Resolution Bandwidth to 1 KHz and Video Resolution Bandwidth to 1KHz. Record this frequency as reference frequency.
3. Supply the EUT primary voltage at the operating end point which is specified by manufacturer and record the frequency.

5.3 TEST SETUP BLOCK DIAGRAM

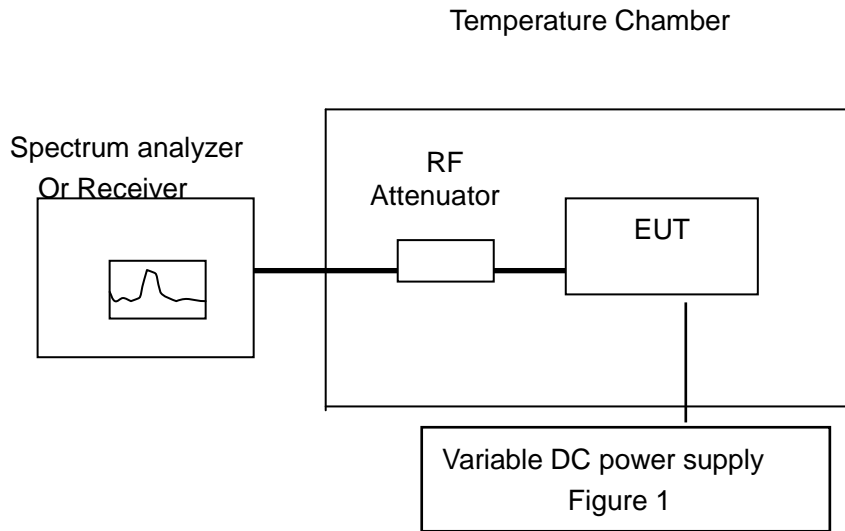

5.3 TEST RESULT

Analog-12.5KHz:

(1) Frequency stability versus input voltage (Supply nominal voltage is 7.40V)-**10W**

Environment Temperature(°C)	Power (V)	Reference Frequency			Limit: ppm
		136.025MHz	155.025MHz	173.975MHz	
50	DC 7.40	0.368	0.782	0.900	5
40	DC 7.40	0.831	0.616	0.910	
30	DC 7.40	0.855	0.881	0.576	
20	DC 7.40	0.883	0.905	0.944	
10	DC 7.40	0.518	0.831	1.098	
0	DC 7.40	0.733	0.880	1.080	
-10	DC 7.40	0.646	0.895	0.759	
-20	DC 7.40	0.790	0.971	0.761	
-30	DC 7.40	0.644	1.069	0.567	
Result	Pass				

Environment Temperature(°C)	Power (V)	Reference Frequency		Limit: ppm
		151.85MHz	161.61MHz	
50	DC 7.40 V	0.932	0.836	5
40	DC 7.40 V	0.493	0.301	
30	DC 7.40 V	0.645	0.448	
20	DC 7.40 V	0.990	0.683	
10	DC 7.40 V	0.767	0.855	
0	DC 7.40 V	0.610	0.646	
-10	DC 7.40 V	0.785	0.703	
-20	DC 7.40 V	0.471	0.368	
-30	DC 7.40 V	0.492	0.571	
Result	Pass			

(2) Frequency stability versus input voltage (Battery limiting voltage is 6.29V) -**10W**

Environment Temperature(°C)	Power (V)	Reference Frequency			Limit: ppm
		136.025MHz	155.025MHz	173.975MHz	
50	DC 6.29	0.924	0.614	0.950	5
40	DC 6.29	0.620	0.822	1.006	
30	DC 6.29	0.919	0.656	1.050	
20	DC 6.29	0.612	0.866	1.099	
10	DC 6.29	0.975	1.064	0.528	
0	DC 6.29	1.037	0.870	1.060	
-10	DC 6.29	0.673	0.616	0.526	
-20	DC 6.29	0.575	0.833	0.808	
-30	DC 6.29	0.586	1.014	0.809	
Result	Pass				

Environment Temperature(°C)	Power	Reference Frequency		Limit:
	(V)	151.85MHz	161.61MHz	ppm
50	DC 6.29	0.802	0.969	5
40	DC 6.29	0.570	0.334	
30	DC 6.29	0.647	0.847	
20	DC 6.29	0.578	0.309	
10	DC 6.29	0.376	0.741	
0	DC 6.29	0.499	0.756	
-10	DC 6.29	0.780	0.431	
-20	DC 6.29	0.907	0.579	
-30	DC 6.29	0.800	0.320	
Result	Pass			

(3) Frequency stability versus input voltage (Battery Fully Charged voltage is 8.51V) **-10W**

Environment Temperature(°C)	Power	Reference Frequency			Limit:
	(V)	136.025MHz	155.025MHz	173.975MHz	ppm
50	DC 8.51	1.062	1.072	0.859	5
40	DC 8.51	0.748	0.826	0.581	
30	DC 8.51	0.662	0.543	0.859	
20	DC 8.51	1.062	0.969	0.818	
10	DC 8.51	0.865	0.973	0.637	
0	DC 8.51	0.746	0.669	0.973	
-10	DC 8.51	0.988	0.620	0.679	
-20	DC 8.51	1.060	1.015	1.052	
-30	DC 8.51	0.762	0.635	0.927	
Result	Pass				

Environment Temperature(°C)	Power	Reference Frequency		Limit:
	(V)	151.85MHz	161.61MHz	ppm
50	DC 8.51	0.807	0.467	5
40	DC 8.51	0.918	0.859	
30	DC 8.51	0.437	0.624	
20	DC 8.51	0.766	0.314	
10	DC 8.51	0.441	0.494	
0	DC 8.51	0.383	0.312	
-10	DC 8.51	0.386	0.541	
-20	DC 8.51	0.698	0.481	
-30	DC 8.51	0.533	0.998	
Result	Pass			

(4) Frequency stability versus input voltage (Battery endpoint is 6V) **-10W**

Environment Temperature(°C)	Power (V)	Reference Frequency			Limit: ppm
		136.025MHz	155.025MHz	173.975MHz	
50	DC 6.00	1.001	0.570	0.763	5
40	DC 6.00	0.663	0.768	0.899	
30	DC 6.00	0.868	0.940	0.500	
20	DC 6.00	0.731	0.613	0.731	
10	DC 6.00	0.762	0.827	0.557	
0	DC 6.00	0.786	0.916	0.953	
-10	DC 6.00	0.702	0.746	0.886	
-20	DC 6.00	1.049	0.712	0.630	
-30	DC 6.00	1.003	0.915	1.083	
Result	Pass				

Environment Temperature(°C)	Power (V)	Reference Frequency		Limit: ppm
		151.85MHz	161.61MHz	
50	DC 6.00 V	0.723	0.886	5
40	DC 6.00 V	0.560	0.988	
30	DC 6.00 V	0.589	0.774	
20	DC 6.00 V	0.957	0.861	
10	DC 6.00 V	0.932	0.593	
0	DC 6.00 V	0.732	0.693	
-10	DC 6.00 V	0.788	0.911	
-20	DC 6.00 V	0.421	0.761	
-30	DC 6.00 V	0.486	0.656	
Result	Pass			

(1) Frequency stability versus input voltage (Supply nominal voltage is 7.40V) **-4.5W**

Environment Temperature(°C)	Power (V)	Reference Frequency			Limit: ppm
		136.025MHz	155.025MHz	173.975MHz	
50	DC 7.40	1.020	0.791	0.740	5
40	DC 7.40	0.930	0.724	0.970	
30	DC 7.40	1.036	0.904	0.783	
20	DC 7.40	0.913	0.558	0.822	
10	DC 7.40	0.627	0.581	0.885	
0	DC 7.40	1.020	0.708	0.535	
-10	DC 7.40	0.893	0.601	0.797	
-20	DC 7.40	0.928	0.730	0.693	
-30	DC 7.40	1.063	0.819	0.813	
Result	Pass				

Environment Temperature(°C)	Power	Reference Frequency		Limit: ppm
	(V)	151.85MHz	161.61MHz	
50	DC 7.40 V	0.567	0.834	5
40	DC 7.40 V	0.549	0.991	
30	DC 7.40 V	0.593	0.737	
20	DC 7.40 V	0.353	0.335	
10	DC 7.40 V	0.749	0.782	
0	DC 7.40 V	0.989	0.808	
-10	DC 7.40 V	0.815	0.627	
-20	DC 7.40 V	0.995	0.600	
-30	DC 7.40 V	0.685	0.800	
Result	Pass			

(2) Frequency stability versus input voltage (Battery limiting voltage is 6.29V) **-4.5W**

Environment Temperature(°C)	Power	Reference Frequency			Limit: ppm
	(V)	136.025MHz	155.025MHz	173.975MHz	
50	DC 6.29	0.726	0.557	1.075	5
40	DC 6.29	0.550	0.735	0.842	
30	DC 6.29	0.503	0.655	0.585	
20	DC 6.29	0.825	0.764	0.654	
10	DC 6.29	0.590	0.653	0.657	
0	DC 6.29	0.870	0.887	1.097	
-10	DC 6.29	0.868	0.749	0.769	
-20	DC 6.29	0.516	0.943	0.502	
-30	DC 6.29	0.978	0.701	1.043	
Result	Pass				

Environment Temperature(°C)	Power	Reference Frequency		Limit: ppm
	(V)	151.85MHz	161.61MHz	
50	DC 6.29	0.408	0.994	5
40	DC 6.29	0.706	0.671	
30	DC 6.29	0.815	0.994	
20	DC 6.29	0.619	0.544	
10	DC 6.29	0.608	0.642	
0	DC 6.29	0.966	0.731	
-10	DC 6.29	0.412	0.929	
-20	DC 6.29	0.641	0.921	
-30	DC 6.29	0.326	0.867	
Result	Pass			

(3) Frequency stability versus input voltage (Battery Fully Charged voltage is 8.51V) **-4.5W**

Environment Temperature(°C)	Power (V)	Reference Frequency			Limit: ppm
		136.025MHz	155.025MHz	173.975MHz	
50	DC 8.51	0.634	0.578	0.983	5
40	DC 8.51	0.830	0.848	0.731	
30	DC 8.51	0.802	0.570	0.817	
20	DC 8.51	1.100	0.869	0.629	
10	DC 8.51	0.600	0.865	0.789	
0	DC 8.51	0.757	0.547	1.059	
-10	DC 8.51	0.535	1.075	0.738	
-20	DC 8.51	0.694	0.978	0.913	
-30	DC 8.51	0.751	0.550	0.889	
Result	Pass				

Environment Temperature(°C)	Power (V)	Reference Frequency		Limit: ppm
		151.85MHz	161.61MHz	
50	DC 8.51	0.523	0.583	5
40	DC 8.51	0.621	1.061	
30	DC 8.51	0.647	0.530	
20	DC 8.51	0.651	1.058	
10	DC 8.51	1.048	0.723	
0	DC 8.51	0.919	0.708	
-10	DC 8.51	0.917	0.569	
-20	DC 8.51	0.550	0.578	
-30	DC 8.51	0.772	0.770	
Result	Pass			

(4) Frequency stability versus input voltage (Battery endpoint is 6V) **-4.5W**

Environment Temperature(°C)	Power (V)	Reference Frequency			Limit: ppm
		136.025MHz	155.025MHz	173.975MHz	
50	DC 6.00	0.972	0.589	0.886	5
40	DC 6.00	0.548	0.718	0.559	
30	DC 6.00	0.814	0.715	0.951	
20	DC 6.00	0.710	1.065	0.622	
10	DC 6.00	1.048	0.559	0.846	
0	DC 6.00	0.728	0.693	0.858	
-10	DC 6.00	0.773	0.779	1.072	
-20	DC 6.00	0.603	1.033	0.797	
-30	DC 6.00	0.897	0.872	0.606	
Result	Pass				

Environment Temperature(°C)	Power	Reference Frequency		Limit: ppm
	(V)	151.85MHz	161.61MHz	
50	DC 6.00 V	0.785	0.571	5
40	DC 6.00 V	1.015	0.640	
30	DC 6.00 V	0.743	0.954	
20	DC 6.00 V	0.874	0.923	
10	DC 6.00 V	0.910	0.721	
0	DC 6.00 V	0.511	0.977	
-10	DC 6.00 V	0.637	0.975	
-20	DC 6.00 V	1.011	0.634	
-30	DC 6.00 V	0.509	0.943	
Result	Pass			

(1) Frequency stability versus input voltage (Supply nominal voltage is 7.40V)-2.5W

Environment Temperature(°C)	Power	Reference Frequency			Limit: ppm
	(V)	136.025MHz	155.025MHz	173.975MHz	
50	DC 7.40	1.071	0.699	0.684	5
40	DC 7.40	0.644	0.931	0.538	
30	DC 7.40	1.026	0.540	1.017	
20	DC 7.40	0.764	0.682	0.849	
10	DC 7.40	0.886	0.771	0.832	
0	DC 7.40	0.897	1.097	0.512	
-10	DC 7.40	0.744	1.038	1.077	
-20	DC 7.40	0.522	0.807	0.582	
-30	DC 7.40	0.610	0.514	0.678	
Result	Pass				

Environment Temperature(°C)	Power	Reference Frequency		Limit: ppm
	(V)	151.85MHz	161.61MHz	
50	DC 7.40 V	0.846	0.637	5
40	DC 7.40 V	1.005	1.073	
30	DC 7.40 V	0.941	0.712	
20	DC 7.40 V	0.638	0.772	
10	DC 7.40 V	0.503	0.632	
0	DC 7.40 V	0.882	0.661	
-10	DC 7.40 V	0.564	1.056	
-20	DC 7.40 V	0.956	1.082	
-30	DC 7.40 V	1.013	0.866	
Result	Pass			

(2) Frequency stability versus input voltage (Battery limiting voltage is 6.29V) **-2.5W**

Environment Temperature(°C)	Power (V)	Reference Frequency			Limit: ppm
		136.025MHz	155.025MHz	173.975MHz	
50	DC 6.29	0.656	0.662	0.656	5
40	DC 6.29	0.744	0.758	0.626	
30	DC 6.29	0.636	0.579	1.063	
20	DC 6.29	0.632	1.034	0.985	
10	DC 6.29	0.637	0.623	0.669	
0	DC 6.29	0.986	1.062	0.574	
-10	DC 6.29	0.795	0.711	0.571	
-20	DC 6.29	0.999	0.777	1.018	
-30	DC 6.29	0.590	0.658	0.804	
Result	Pass				

Environment Temperature(°C)	Power (V)	Reference Frequency		Limit: ppm
		151.85MHz	161.61MHz	
50	DC 6.29	0.795	1.009	5
40	DC 6.29	1.039	0.674	
30	DC 6.29	0.910	0.802	
20	DC 6.29	1.075	1.091	
10	DC 6.29	0.760	1.031	
0	DC 6.29	1.095	0.971	
-10	DC 6.29	1.036	0.780	
-20	DC 6.29	0.840	0.771	
-30	DC 6.29	0.634	0.509	
Result	Pass			

(3) Frequency stability versus input voltage (Battery Fully Charged voltage is 8.51V) **-2.5W**

Environment Temperature(°C)	Power (V)	Reference Frequency			Limit: ppm
		136.025MHz	155.025MHz	173.975MHz	
50	DC 8.51	0.754	0.743	1.068	5
40	DC 8.51	0.824	1.027	0.512	
30	DC 8.51	0.643	1.044	0.869	
20	DC 8.51	0.667	0.743	0.760	
10	DC 8.51	0.537	0.811	0.606	
0	DC 8.51	0.639	0.531	0.982	
-10	DC 8.51	0.501	1.096	0.631	
-20	DC 8.51	0.988	0.564	1.051	
-30	DC 8.51	0.857	0.705	1.017	
Result	Pass				

Environment Temperature(°C)	Power	Reference Frequency		Limit: ppm
	(V)	151.85MHz	161.61MHz	
50	DC 8.51	0.692	0.813	5
40	DC 8.51	0.914	0.849	
30	DC 8.51	0.962	1.039	
20	DC 8.51	0.647	0.965	
10	DC 8.51	0.835	0.928	
0	DC 8.51	0.732	1.021	
-10	DC 8.51	0.937	0.879	
-20	DC 8.51	0.702	1.052	
-30	DC 8.51	0.919	0.665	
Result	Pass			

(4) Frequency stability versus input voltage (Battery endpoint is 6V) **-2.5W**

Environment Temperature(°C)	Power	Reference Frequency			Limit: ppm
	(V)	136.025MHz	155.025MHz	173.975MHz	
50	DC 6.00	0.683	0.505	0.629	5
40	DC 6.00	0.736	0.823	0.645	
30	DC 6.00	0.926	1.003	0.671	
20	DC 6.00	1.023	0.620	0.700	
10	DC 6.00	0.618	0.902	0.756	
0	DC 6.00	1.066	0.764	0.905	
-10	DC 6.00	0.549	0.641	0.787	
-20	DC 6.00	1.060	0.831	1.002	
-30	DC 6.00	0.592	0.760	0.722	
Result	Pass				

Environment Temperature(°C)	Power	Reference Frequency		Limit: ppm
	(V)	151.85MHz	161.61MHz	
50	DC 6.00 V	1.048	1.049	5
40	DC 6.00 V	0.702	0.648	
30	DC 6.00 V	0.902	0.780	
20	DC 6.00 V	1.040	1.070	
10	DC 6.00 V	0.868	0.562	
0	DC 6.00 V	0.605	0.503	
-10	DC 6.00 V	0.694	0.833	
-20	DC 6.00 V	0.713	0.530	
-30	DC 6.00 V	0.765	0.636	
Result	Pass			

(1) Frequency stability versus input voltage (Supply nominal voltage is 7.40V)-1W

Environment Temperature(°C)	Power (V)	Reference Frequency			Limit: ppm
		136.025MHz	155.025MHz	173.975MHz	
50	DC 7.40	1.021	0.518	1.020	5
40	DC 7.40	1.087	0.883	0.695	
30	DC 7.40	0.768	0.633	1.061	
20	DC 7.40	0.743	0.925	0.974	
10	DC 7.40	0.643	0.578	0.739	
0	DC 7.40	0.846	0.558	0.985	
-10	DC 7.40	0.785	0.528	0.978	
-20	DC 7.40	0.879	0.810	0.989	
-30	DC 7.40	0.846	0.648	0.577	
Result	Pass				

Environment Temperature(°C)	Power (V)	Reference Frequency		Limit: ppm
		151.85MHz	161.61MHz	
50	DC 7.40 V	0.528	1.034	5
40	DC 7.40 V	0.723	1.045	
30	DC 7.40 V	0.840	0.701	
20	DC 7.40 V	0.682	0.614	
10	DC 7.40 V	0.866	0.609	
0	DC 7.40 V	0.668	0.557	
-10	DC 7.40 V	0.776	0.551	
-20	DC 7.40 V	0.815	0.705	
-30	DC 7.40 V	0.596	0.923	
Result	Pass			

(2) Frequency stability versus input voltage (Battery limiting voltage is 6.29V) -1W

Environment Temperature(°C)	Power (V)	Reference Frequency			Limit: ppm
		136.025MHz	155.025MHz	173.975MHz	
50	DC 6.29	1.072	0.938	0.635	5
40	DC 6.29	0.735	0.824	1.068	
30	DC 6.29	0.930	0.778	0.987	
20	DC 6.29	0.977	1.079	0.560	
10	DC 6.29	1.096	0.639	0.922	
0	DC 6.29	0.895	0.929	1.013	
-10	DC 6.29	1.048	0.728	0.734	
-20	DC 6.29	0.830	0.574	1.069	
-30	DC 6.29	0.679	0.984	0.700	
Result	Pass				

Environment Temperature(°C)	Power	Reference Frequency		Limit:
	(V)	151.85MHz	161.61MHz	ppm
50	DC 6.29	1.067	0.843	5
40	DC 6.29	0.898	0.962	
30	DC 6.29	0.928	0.753	
20	DC 6.29	0.706	1.049	
10	DC 6.29	0.647	0.884	
0	DC 6.29	0.837	0.658	
-10	DC 6.29	0.770	0.601	
-20	DC 6.29	0.684	0.740	
-30	DC 6.29	0.682	0.523	
Result	Pass			

(3) Frequency stability versus input voltage (Battery Fully Charged voltage is 8.51V) -1W

Environment Temperature(°C)	Power	Reference Frequency			Limit:
	(V)	136.025MHz	155.025MHz	173.975MHz	ppm
50	DC 8.51	1.067	0.843	0.663	5
40	DC 8.51	0.898	0.962	0.630	
30	DC 8.51	0.928	0.753	1.087	
20	DC 8.51	0.706	1.049	0.921	
10	DC 8.51	0.647	0.884	0.547	
0	DC 8.51	0.837	0.658	0.923	
-10	DC 8.51	0.770	0.601	1.096	
-20	DC 8.51	0.684	0.740	0.931	
-30	DC 8.51	0.682	0.523	0.681	
Result	Pass				

Environment Temperature(°C)	Power	Reference Frequency		Limit:
	(V)	151.85MHz	161.61MHz	ppm
50	DC 8.51	0.782	1.023	5
40	DC 8.51	1.098	0.936	
30	DC 8.51	0.919	1.045	
20	DC 8.51	0.622	1.049	
10	DC 8.51	0.695	1.024	
0	DC 8.51	0.627	0.611	
-10	DC 8.51	0.807	0.903	
-20	DC 8.51	0.832	0.678	
-30	DC 8.51	0.571	0.536	
Result	Pass			

(4) Frequency stability versus input voltage (Battery endpoint is 6V) -1W

Environment Temperature(°C)	Power (V)	Reference Frequency			Limit: ppm
		136.025MHz	155.025MHz	173.975MHz	
50	DC 6.00	0.722	0.648	1.016	5
40	DC 6.00	0.862	0.769	1.027	
30	DC 6.00	0.926	0.812	1.058	
20	DC 6.00	0.904	1.010	1.055	
10	DC 6.00	1.029	0.989	0.669	
0	DC 6.00	0.663	0.766	1.001	
-10	DC 6.00	0.710	0.693	1.052	
-20	DC 6.00	0.894	0.600	0.937	
-30	DC 6.00	0.539	0.845	0.734	
Result	Pass				

Environment Temperature(°C)	Power (V)	Reference Frequency		Limit: ppm
		151.85MHz	161.61MHz	
50	DC 6.00 V	0.839	0.965	5
40	DC 6.00 V	0.926	1.090	
30	DC 6.00 V	0.825	1.031	
20	DC 6.00 V	1.071	0.593	
10	DC 6.00 V	0.614	0.683	
0	DC 6.00 V	1.033	0.513	
-10	DC 6.00 V	0.890	0.983	
-20	DC 6.00 V	0.831	0.832	
-30	DC 6.00 V	0.509	1.081	
Result	Pass			

Digital-12.5KHz:

(1) Frequency stability versus input voltage (Supply nominal voltage is 7.40V)-**10W**

Environment Temperature(°C)	Power (V)	Reference Frequency			Limit: ppm
		136.025MHz	155.025MHz	173.975MHz	
50	DC 7.40	0.617	0.579	0.683	5
40	DC 7.40	0.811	0.966	0.928	
30	DC 7.40	0.823	0.607	1.004	
20	DC 7.40	0.591	0.578	0.749	
10	DC 7.40	0.615	0.590	0.765	
0	DC 7.40	0.855	0.800	0.523	
-10	DC 7.40	0.638	0.993	0.819	
-20	DC 7.40	0.541	0.523	0.830	
-30	DC 7.40	0.594	0.864	1.040	
Result	Pass				

Environment Temperature(°C)	Power (V)	Reference Frequency		Limit: ppm
		151.85MHz	161.61MHz	
50	DC 7.40 V	1.067	1.085	5
40	DC 7.40 V	0.872	0.861	
30	DC 7.40 V	0.990	0.666	
20	DC 7.40 V	0.506	0.705	
10	DC 7.40 V	0.734	0.701	
0	DC 7.40 V	0.933	0.798	
-10	DC 7.40 V	0.970	0.856	
-20	DC 7.40 V	0.670	0.595	
-30	DC 7.40 V	1.076	1.035	
Result	Pass			

(2) Frequency stability versus input voltage (Battery limiting voltage is 6.29V) -**10W**

Environment Temperature(°C)	Power (V)	Reference Frequency			Limit: ppm
		136.025MHz	155.025MHz	173.975MHz	
50	DC 6.29	0.836	1.028	0.916	5
40	DC 6.29	1.099	0.640	0.952	
30	DC 6.29	0.675	0.564	0.654	
20	DC 6.29	0.988	0.675	1.010	
10	DC 6.29	0.953	1.009	1.051	
0	DC 6.29	0.691	0.748	0.516	
-10	DC 6.29	0.687	0.879	0.530	
-20	DC 6.29	0.687	1.074	0.809	
-30	DC 6.29	0.758	0.837	0.579	
Result	Pass				

Environment Temperature(°C)	Power	Reference Frequency		Limit:
	(V)	151.85MHz	161.61MHz	ppm
50	DC 6.29	0.584	0.875	5
40	DC 6.29	0.670	1.080	
30	DC 6.29	0.828	0.878	
20	DC 6.29	0.824	1.019	
10	DC 6.29	0.770	0.576	
0	DC 6.29	1.067	0.906	
-10	DC 6.29	0.900	0.557	
-20	DC 6.29	0.632	0.840	
-30	DC 6.29	0.918	0.767	
Result	Pass			

(3) Frequency stability versus input voltage (Battery Fully Charged voltage is 8.51V) **-10W**

Environment Temperature(°C)	Power	Reference Frequency			Limit:
	(V)	136.025MHz	155.025MHz	173.975MHz	ppm
50	DC 8.51	0.707	0.786	0.568	5
40	DC 8.51	0.591	0.574	0.911	
30	DC 8.51	0.502	0.538	0.663	
20	DC 8.51	0.777	1.000	0.965	
10	DC 8.51	0.732	0.736	0.971	
0	DC 8.51	0.970	0.951	0.591	
-10	DC 8.51	0.959	0.782	0.780	
-20	DC 8.51	0.922	1.074	1.007	
-30	DC 8.51	0.699	0.854	0.750	
Result	Pass				

Environment Temperature(°C)	Power	Reference Frequency		Limit:
	(V)	151.85MHz	161.61MHz	ppm
50	DC 8.51	1.085	1.093	5
40	DC 8.51	0.649	0.931	
30	DC 8.51	0.955	0.891	
20	DC 8.51	1.004	0.558	
10	DC 8.51	0.596	0.850	
0	DC 8.51	0.815	0.886	
-10	DC 8.51	0.906	0.668	
-20	DC 8.51	0.794	0.559	
-30	DC 8.51	0.604	0.968	
Result	Pass			

(4) Frequency stability versus input voltage (Battery endpoint is 6V) **-10W**

Environment Temperature(°C)	Power (V)	Reference Frequency			Limit: ppm
		136.025MHz	155.025MHz	173.975MHz	
50	DC 6.00	0.520	0.792	0.857	5
40	DC 6.00	0.686	0.648	0.842	
30	DC 6.00	0.671	0.948	0.761	
20	DC 6.00	0.517	1.075	0.754	
10	DC 6.00	1.086	0.688	0.558	
0	DC 6.00	0.529	0.516	0.890	
-10	DC 6.00	1.024	0.674	0.935	
-20	DC 6.00	0.621	1.091	1.011	
-30	DC 6.00	0.764	1.003	0.642	
Result	Pass				

Environment Temperature(°C)	Power (V)	Reference Frequency		Limit: ppm
		151.85MHz	161.61MHz	
50	DC 6.00 V	0.919	0.831	5
40	DC 6.00 V	1.080	0.593	
30	DC 6.00 V	1.075	0.843	
20	DC 6.00 V	0.852	0.600	
10	DC 6.00 V	0.667	0.903	
0	DC 6.00 V	0.753	0.714	
-10	DC 6.00 V	0.795	0.544	
-20	DC 6.00 V	0.911	0.572	
-30	DC 6.00 V	0.930	0.844	
Result	Pass			

(1) Frequency stability versus input voltage (Supply nominal voltage is 7.40V) **-4.5W**

Environment Temperature(°C)	Power (V)	Reference Frequency			Limit: ppm
		136.025MHz	155.025MHz	173.975MHz	
50	DC 7.40	0.714	0.895	0.885	5
40	DC 7.40	0.966	0.965	0.594	
30	DC 7.40	0.753	1.026	0.789	
20	DC 7.40	0.870	0.838	0.634	
10	DC 7.40	0.540	0.521	0.872	
0	DC 7.40	0.896	0.973	0.645	
-10	DC 7.40	0.839	0.909	0.699	
-20	DC 7.40	1.091	0.746	0.608	
-30	DC 7.40	0.792	1.077	0.791	
Result	Pass				

Environment Temperature(°C)	Power	Reference Frequency		Limit: ppm
	(V)	151.85MHz	161.61MHz	
50	DC 7.40 V	0.692	0.927	5
40	DC 7.40 V	0.630	0.880	
30	DC 7.40 V	0.559	0.978	
20	DC 7.40 V	0.570	0.657	
10	DC 7.40 V	0.988	0.784	
0	DC 7.40 V	0.536	0.832	
-10	DC 7.40 V	1.066	1.011	
-20	DC 7.40 V	0.575	0.813	
-30	DC 7.40 V	0.510	0.753	
Result	Pass			

(2) Frequency stability versus input voltage (Battery limiting voltage is 6.29V) **-4.5W**

Environment Temperature(°C)	Power	Reference Frequency			Limit: ppm
	(V)	136.025MHz	155.025MHz	173.975MHz	
50	DC 6.29	0.538	0.626	0.967	5
40	DC 6.29	0.861	0.724	0.701	
30	DC 6.29	0.583	0.857	0.571	
20	DC 6.29	0.775	0.622	0.895	
10	DC 6.29	0.693	0.698	0.663	
0	DC 6.29	0.782	0.758	0.538	
-10	DC 6.29	0.869	0.757	0.645	
-20	DC 6.29	0.849	0.546	0.770	
-30	DC 6.29	0.691	1.050	0.733	
Result	Pass				

Environment Temperature(°C)	Power	Reference Frequency		Limit: ppm
	(V)	151.85MHz	161.61MHz	
50	DC 6.29	0.810	0.560	5
40	DC 6.29	0.912	1.060	
30	DC 6.29	0.779	0.581	
20	DC 6.29	0.579	0.692	
10	DC 6.29	0.699	0.974	
0	DC 6.29	0.600	0.798	
-10	DC 6.29	0.602	0.994	
-20	DC 6.29	0.721	0.558	
-30	DC 6.29	0.910	0.683	
Result	Pass			

(3) Frequency stability versus input voltage (Battery Fully Charged voltage is 8.51V) **-4.5W**

Environment Temperature(°C)	Power (V)	Reference Frequency			Limit: ppm
		136.025MHz	155.025MHz	173.975MHz	
50	DC 8.51	0.713	1.030	0.867	5
40	DC 8.51	0.914	0.508	0.735	
30	DC 8.51	0.604	0.582	0.592	
20	DC 8.51	0.901	0.910	0.553	
10	DC 8.51	0.936	0.893	0.999	
0	DC 8.51	0.690	0.708	0.606	
-10	DC 8.51	0.673	0.694	0.832	
-20	DC 8.51	0.894	0.529	0.825	
-30	DC 8.51	0.548	0.708	0.614	
Result	Pass				

Environment Temperature(°C)	Power (V)	Reference Frequency		Limit: ppm
		151.85MHz	161.61MHz	
50	DC 8.51	0.555	0.827	5
40	DC 8.51	0.714	0.587	
30	DC 8.51	0.677	0.815	
20	DC 8.51	0.546	0.728	
10	DC 8.51	0.571	0.957	
0	DC 8.51	1.012	0.680	
-10	DC 8.51	1.037	0.778	
-20	DC 8.51	1.094	0.730	
-30	DC 8.51	0.637	1.071	
Result	Pass			

(4) Frequency stability versus input voltage (Battery endpoint is 6V) **-4.5W**

Environment Temperature(°C)	Power (V)	Reference Frequency			Limit: ppm
		136.025MHz	155.025MHz	173.975MHz	
50	DC 6.00	0.653	0.840	0.662	5
40	DC 6.00	0.854	0.712	0.801	
30	DC 6.00	0.930	0.663	0.515	
20	DC 6.00	1.018	0.505	0.782	
10	DC 6.00	0.831	1.089	0.699	
0	DC 6.00	0.613	0.723	1.060	
-10	DC 6.00	0.810	0.813	0.732	
-20	DC 6.00	0.822	0.939	0.933	
-30	DC 6.00	0.849	1.037	0.710	
Result	Pass				

Environment Temperature(°C)	Power	Reference Frequency		Limit: ppm
	(V)	151.85MHz	161.61MHz	
50	DC 6.00 V	0.816	0.804	5
40	DC 6.00 V	0.793	0.881	
30	DC 6.00 V	0.598	0.742	
20	DC 6.00 V	0.977	0.590	
10	DC 6.00 V	0.548	0.509	
0	DC 6.00 V	0.901	0.696	
-10	DC 6.00 V	1.081	0.768	
-20	DC 6.00 V	0.942	0.559	
-30	DC 6.00 V	0.554	1.080	
Result	Pass			

(1) Frequency stability versus input voltage (Supply nominal voltage is 7.40V)-2.5W

Environment Temperature(°C)	Power	Reference Frequency			Limit: ppm
	(V)	136.025MHz	155.025MHz	173.975MHz	
50	DC 7.40	0.575	1.043	0.997	5
40	DC 7.40	0.514	0.921	0.779	
30	DC 7.40	0.681	0.778	0.728	
20	DC 7.40	1.059	0.594	0.790	
10	DC 7.40	0.699	1.032	0.527	
0	DC 7.40	0.716	1.046	0.957	
-10	DC 7.40	0.952	0.829	0.545	
-20	DC 7.40	0.997	0.558	1.089	
-30	DC 7.40	1.000	0.576	0.817	
Result	Pass				

Environment Temperature(°C)	Power	Reference Frequency		Limit: ppm
	(V)	151.85MHz	161.61MHz	
50	DC 7.40 V	0.698	0.779	5
40	DC 7.40 V	0.987	0.788	
30	DC 7.40 V	0.833	0.501	
20	DC 7.40 V	0.766	1.046	
10	DC 7.40 V	0.913	0.680	
0	DC 7.40 V	0.630	0.601	
-10	DC 7.40 V	0.538	0.533	
-20	DC 7.40 V	0.927	0.771	
-30	DC 7.40 V	0.710	0.742	
Result	Pass			

(2) Frequency stability versus input voltage (Battery limiting voltage is 6.29V) **-2.5W**

Environment Temperature(°C)	Power (V)	Reference Frequency			Limit: ppm
		136.025MHz	155.025MHz	173.975MHz	
50	DC 6.29	0.573	1.094	0.760	5
40	DC 6.29	0.612	0.893	0.920	
30	DC 6.29	0.884	1.080	0.502	
20	DC 6.29	0.846	0.842	0.741	
10	DC 6.29	0.983	0.889	1.074	
0	DC 6.29	0.963	1.010	1.057	
-10	DC 6.29	0.728	0.852	0.613	
-20	DC 6.29	0.779	0.670	0.865	
-30	DC 6.29	0.717	0.695	0.782	
Result	Pass				

Environment Temperature(°C)	Power (V)	Reference Frequency		Limit: ppm
		151.85MHz	161.61MHz	
50	DC 6.29	0.711	1.065	5
40	DC 6.29	0.919	1.092	
30	DC 6.29	1.089	0.631	
20	DC 6.29	1.024	0.922	
10	DC 6.29	0.802	0.507	
0	DC 6.29	0.761	1.063	
-10	DC 6.29	1.037	0.689	
-20	DC 6.29	0.653	0.749	
-30	DC 6.29	0.822	0.929	
Result	Pass			

(3) Frequency stability versus input voltage (Battery Fully Charged voltage is 8.51V) **-2.5W**

Environment Temperature(°C)	Power (V)	Reference Frequency			Limit: ppm
		136.025MHz	155.025MHz	173.975MHz	
50	DC 8.51	0.610	1.047	0.797	5
40	DC 8.51	0.805	0.753	0.667	
30	DC 8.51	0.848	1.071	0.702	
20	DC 8.51	1.079	0.948	0.527	
10	DC 8.51	0.637	0.692	0.773	
0	DC 8.51	1.086	0.865	0.860	
-10	DC 8.51	0.597	0.758	0.859	
-20	DC 8.51	0.969	0.872	0.736	
-30	DC 8.51	0.588	0.697	0.509	
Result	Pass				

Environment Temperature(°C)	Power	Reference Frequency		Limit: ppm
	(V)	151.85MHz	161.61MHz	
50	DC 8.51	0.534	1.041	5
40	DC 8.51	0.892	0.913	
30	DC 8.51	0.818	0.989	
20	DC 8.51	0.792	0.787	
10	DC 8.51	0.780	0.883	
0	DC 8.51	0.580	0.521	
-10	DC 8.51	1.072	1.060	
-20	DC 8.51	0.715	0.615	
-30	DC 8.51	0.948	0.951	
Result	Pass			

(4) Frequency stability versus input voltage (Battery endpoint is 6V) **-2.5W**

Environment Temperature(°C)	Power	Reference Frequency			Limit: ppm
	(V)	136.025MHz	155.025MHz	173.975MHz	
50	DC 6.00	0.905	0.530	0.568	5
40	DC 6.00	0.541	0.990	1.006	
30	DC 6.00	0.591	0.772	0.610	
20	DC 6.00	0.538	0.665	0.977	
10	DC 6.00	0.719	0.650	0.975	
0	DC 6.00	0.742	0.826	1.045	
-10	DC 6.00	1.032	1.075	0.543	
-20	DC 6.00	1.069	0.692	0.583	
-30	DC 6.00	0.898	0.659	0.875	
Result	Pass				

Environment Temperature(°C)	Power	Reference Frequency		Limit: ppm
	(V)	151.85MHz	161.61MHz	
50	DC 6.00 V	0.524	0.551	5
40	DC 6.00 V	1.020	0.745	
30	DC 6.00 V	0.522	1.069	
20	DC 6.00 V	0.604	0.991	
10	DC 6.00 V	1.021	1.034	
0	DC 6.00 V	0.704	0.757	
-10	DC 6.00 V	0.997	0.569	
-20	DC 6.00 V	0.515	0.790	
-30	DC 6.00 V	0.582	1.089	
Result	Pass			

(1) Frequency stability versus input voltage (Supply nominal voltage is 7.40V)-1W

Environment Temperature(°C)	Power (V)	Reference Frequency			Limit: ppm
		136.025MHz	155.025MHz	173.975MHz	
50	DC 7.40	1.079	0.619	0.926	5
40	DC 7.40	0.818	0.945	0.863	
30	DC 7.40	0.765	0.875	0.985	
20	DC 7.40	0.595	0.663	0.758	
10	DC 7.40	0.700	1.011	1.062	
0	DC 7.40	0.649	0.511	0.920	
-10	DC 7.40	0.933	0.806	0.642	
-20	DC 7.40	0.849	0.994	0.539	
-30	DC 7.40	1.071	0.936	0.939	
Result	Pass				

Environment Temperature(°C)	Power (V)	Reference Frequency		Limit: ppm
		151.85MHz	161.61MHz	
50	DC 7.40 V	1.063	0.736	5
40	DC 7.40 V	0.560	1.098	
30	DC 7.40 V	1.069	0.614	
20	DC 7.40 V	0.946	1.049	
10	DC 7.40 V	0.874	0.608	
0	DC 7.40 V	0.589	0.629	
-10	DC 7.40 V	0.704	0.712	
-20	DC 7.40 V	1.022	0.625	
-30	DC 7.40 V	0.924	1.017	
Result	Pass			

(2) Frequency stability versus input voltage (Battery limiting voltage is 6.29V) -1W

Environment Temperature(°C)	Power (V)	Reference Frequency			Limit: ppm
		136.025MHz	155.025MHz	173.975MHz	
50	DC 6.29	0.675	0.806	0.852	5
40	DC 6.29	1.076	0.573	0.952	
30	DC 6.29	0.794	0.738	1.070	
20	DC 6.29	0.975	0.614	0.880	
10	DC 6.29	0.547	0.811	0.984	
0	DC 6.29	1.085	0.551	0.677	
-10	DC 6.29	0.515	0.969	0.602	
-20	DC 6.29	0.529	0.623	0.980	
-30	DC 6.29	0.653	1.041	0.930	
Result	Pass				

Environment Temperature(°C)	Power	Reference Frequency		Limit:
	(V)	151.85MHz	161.61MHz	ppm
50	DC 6.29	0.816	0.654	5
40	DC 6.29	1.029	1.077	
30	DC 6.29	0.944	0.546	
20	DC 6.29	0.685	0.927	
10	DC 6.29	0.889	0.504	
0	DC 6.29	1.077	0.728	
-10	DC 6.29	0.921	0.767	
-20	DC 6.29	0.982	0.995	
-30	DC 6.29	0.609	1.018	
Result	Pass			

(3) Frequency stability versus input voltage (Battery Fully Charged voltage is 8.51V) **-1W**

Environment Temperature(°C)	Power	Reference Frequency			Limit:
	(V)	136.025MHz	155.025MHz	173.975MHz	ppm
50	DC 8.51	0.579	0.784	0.921	5
40	DC 8.51	0.765	0.860	1.019	
30	DC 8.51	0.874	0.802	0.586	
20	DC 8.51	0.554	0.649	1.086	
10	DC 8.51	0.615	0.799	0.835	
0	DC 8.51	0.905	0.980	0.992	
-10	DC 8.51	1.021	0.819	0.662	
-20	DC 8.51	0.605	0.890	1.074	
-30	DC 8.51	1.034	0.751	0.820	
Result	Pass				

Environment Temperature(°C)	Power	Reference Frequency		Limit:
	(V)	151.85MHz	161.61MHz	ppm
50	DC 8.51	1.089	1.005	5
40	DC 8.51	0.683	0.778	
30	DC 8.51	0.791	0.506	
20	DC 8.51	0.867	0.924	
10	DC 8.51	0.817	0.697	
0	DC 8.51	1.093	0.874	
-10	DC 8.51	1.071	0.986	
-20	DC 8.51	0.821	0.887	
-30	DC 8.51	0.748	0.673	
Result	Pass			

(4) Frequency stability versus input voltage (Battery endpoint is 6V) -1W

Environment Temperature(°C)	Power (V)	Reference Frequency			Limit: ppm
		136.025MHz	155.025MHz	173.975MHz	
50	DC 6.00	0.908	1.059	0.852	5
40	DC 6.00	0.938	0.808	0.807	
30	DC 6.00	0.500	0.759	0.705	
20	DC 6.00	1.048	0.760	1.043	
10	DC 6.00	0.648	0.512	0.615	
0	DC 6.00	0.744	0.639	0.911	
-10	DC 6.00	0.883	0.650	0.948	
-20	DC 6.00	0.588	0.634	0.926	
-30	DC 6.00	0.975	0.796	0.673	
Result	Pass				

Environment Temperature(°C)	Power (V)	Reference Frequency		Limit: ppm
		151.85MHz	161.61MHz	
50	DC 6.00 V	0.875	0.537	5
40	DC 6.00 V	0.790	0.610	
30	DC 6.00 V	0.758	1.368	
20	DC 6.00 V	0.989	1.060	
10	DC 6.00 V	0.618	0.857	
0	DC 6.00 V	0.639	0.687	
-10	DC 6.00 V	0.772	1.052	
-20	DC 6.00 V	0.755	0.979	
-30	DC 6.00 V	0.946	0.574	
Result	Pass			

6. EMISSION BANDWIDTH

6.1 PROVISIONS APPLICABLE

FCC Part 90 & FCC Part 22:

The authorized bandwidth shall be 11.25 KHz for 12.5 KHz channel separation and 20 KHz for 25 KHz channel separation.

6.2 MEASUREMENT PROCEDURE

- 1). The EUT was modulated by 2.5 KHz Sine wave audio signal, The level of the audio signal employed is 16 dB greater than that necessary to produce 50% of rated system deviation. Rated system deviation is 2.5 kHz (12.5 kHz channel spacing).
- 2). Set SPA Center Frequency = fundamental frequency, RBW=100Hz.VBW= 300 Hz, Span =50 KHz.
- 3). Set SPA Max hold. Mark peak, -26 dB.

6.3 TEST SETUP BLOCK DIAGRAM

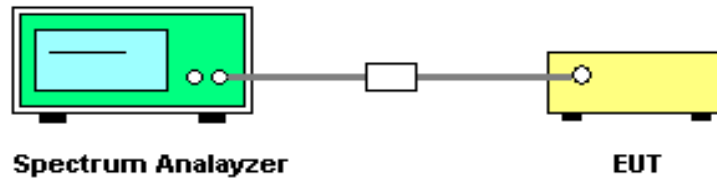

6.4 MEASUREMENT RESULT

Analog-12.5:

26 dB Bandwidth Measurement Result			
Operating Frequency	12.5 KHz Channel Separation		
	Test Data	Limits	Result
136.025MHz	10.07KHz	11.25 KHz	Pass
151.850MHz	10.18KHz	11.25 KHz	Pass
155.025MHz	10.05KHz	11.25 KHz	Pass
161.61 MHz	10.16KHz	11.25 KHz	Pass
173.975MHz	10.11KHz	11.25 KHz	Pass

Occupied bandwidth of Middle Channel (151.850 MHz)-10W

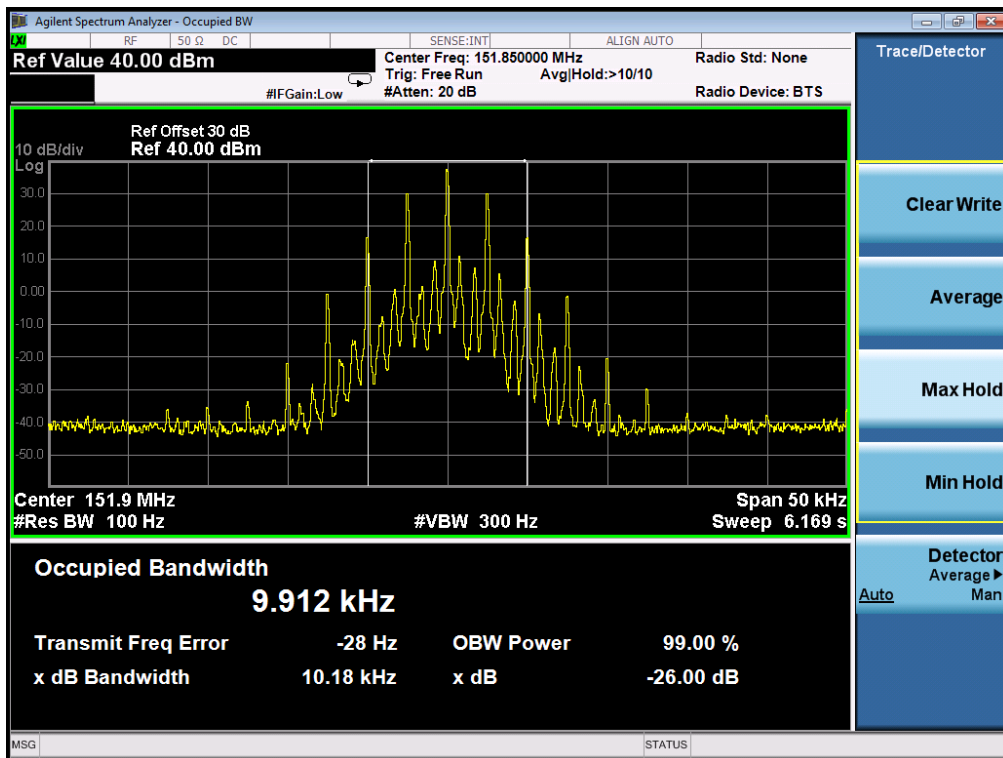

Occupied bandwidth of Middle Channel (161.610 MHz)-10W

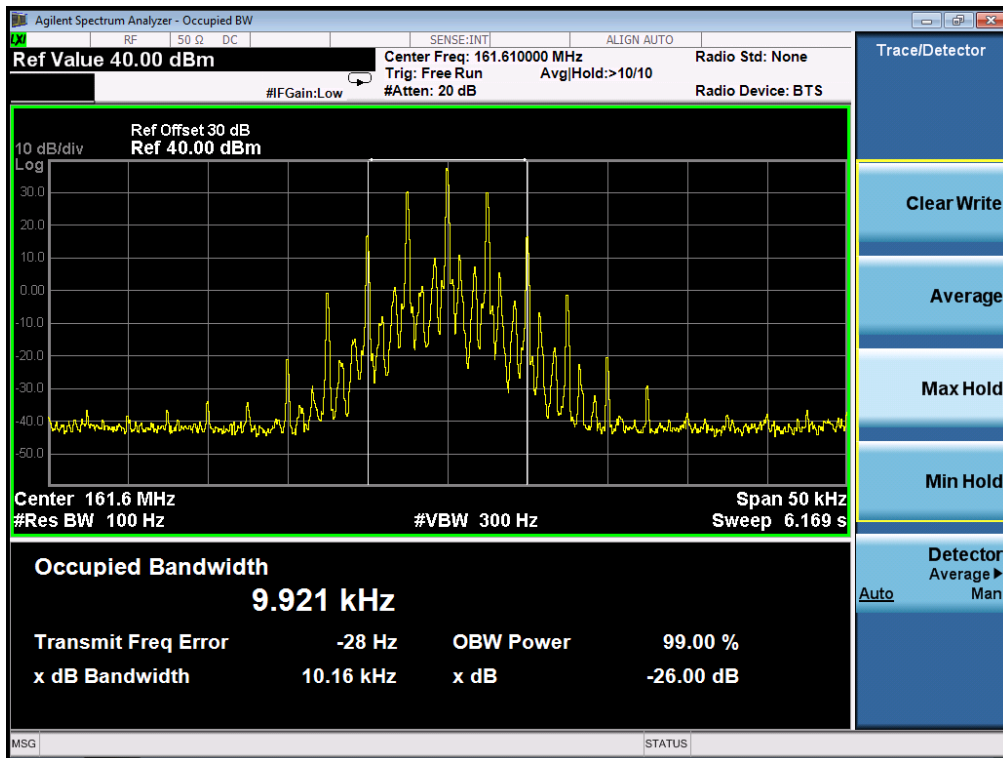

26 dB Bandwidth Measurement Result			
Operating Frequency	12.5 KHz Channel Separation		
	Test Data	Limits	Result
136.025MHz	10.09KHz	11.25 KHz	Pass
151.850MHz	10.12KHz	11.25 KHz	Pass
155.025MHz	10.08KHz	11.25 KHz	Pass
161.61 MHz	10.16KHz	11.25 KHz	Pass
173.975MHz	10.05KHz	11.25 KHz	Pass

Occupied bandwidth of Middle Channel (151.850 MHz)-4.5W

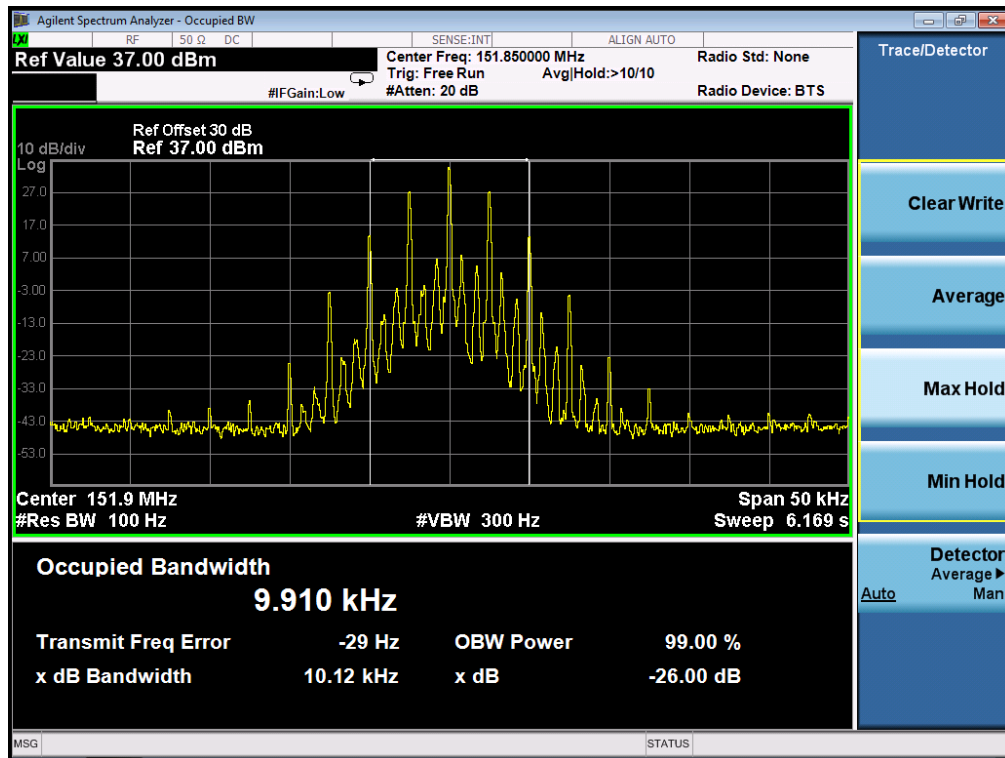

Occupied bandwidth of Middle Channel (161.610 MHz)-4.5W

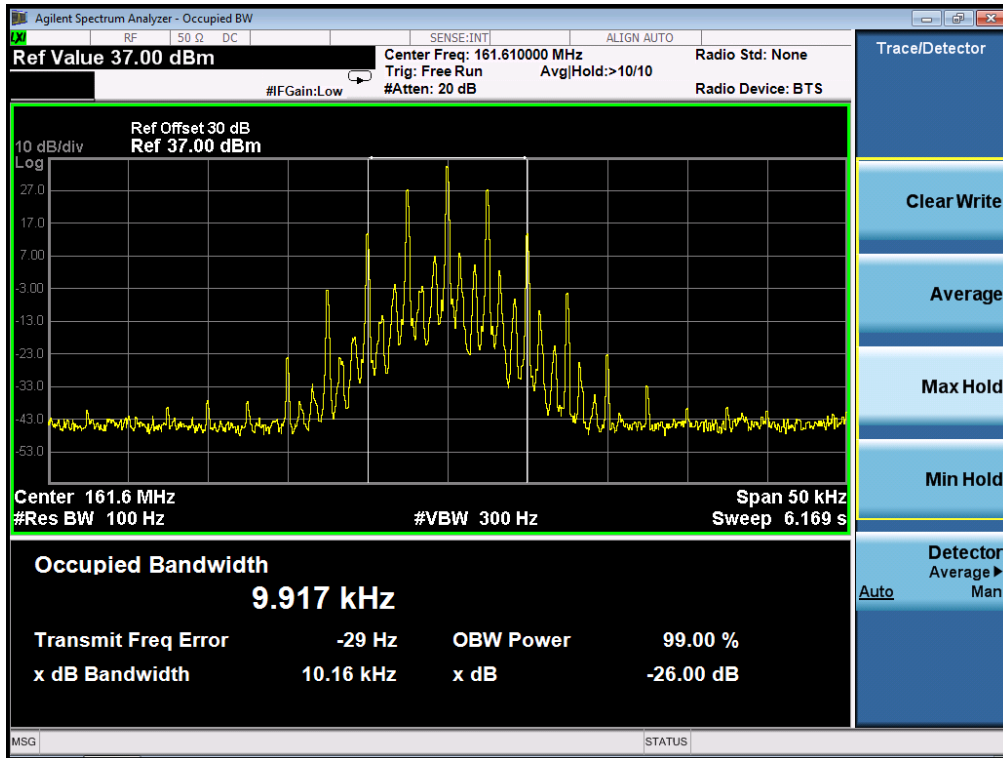

26 dB Bandwidth Measurement Result			
Operating Frequency	12.5 KHz Channel Separation		
	Test Data	Limits	Result
136.025MHz	10.13KHz	11.25 KHz	Pass
151.850MHz	10.19KHz	11.25 KHz	Pass
155.025MHz	10.11KHz	11.25 KHz	Pass
161.61 MHz	10.17KHz	11.25 KHz	Pass
173.975MHz	10.05KHz	11.25 KHz	Pass

Occupied bandwidth of Middle Channel (151.850 MHz)-2.5W

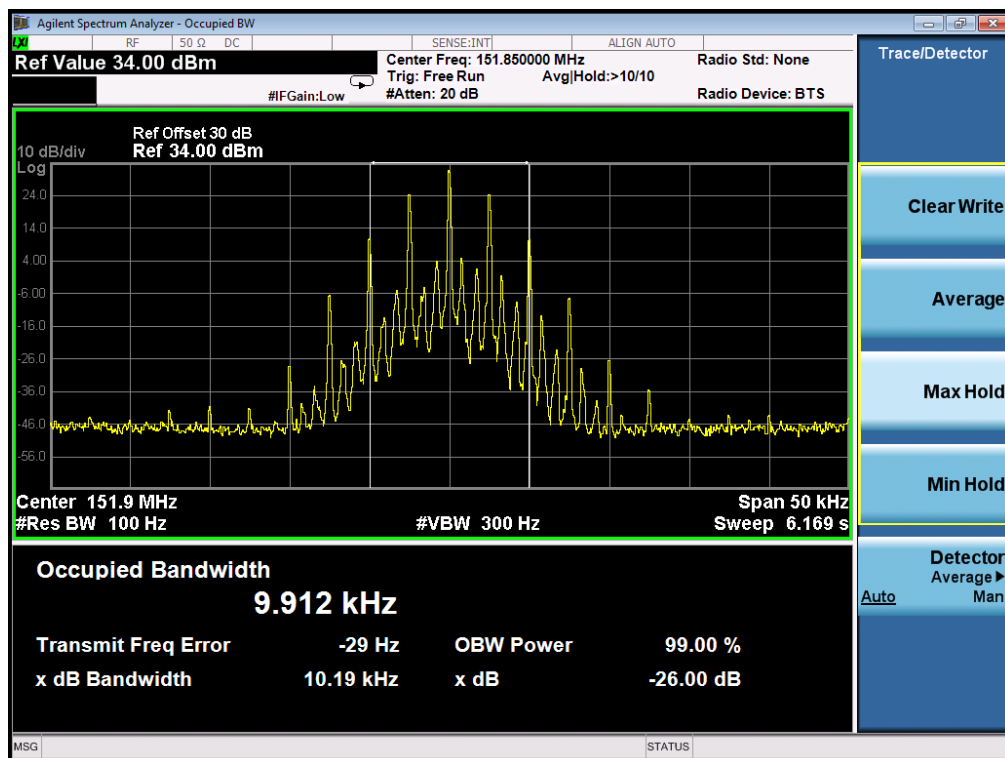

Occupied bandwidth of Middle Channel (161.610 MHz)-2.5W

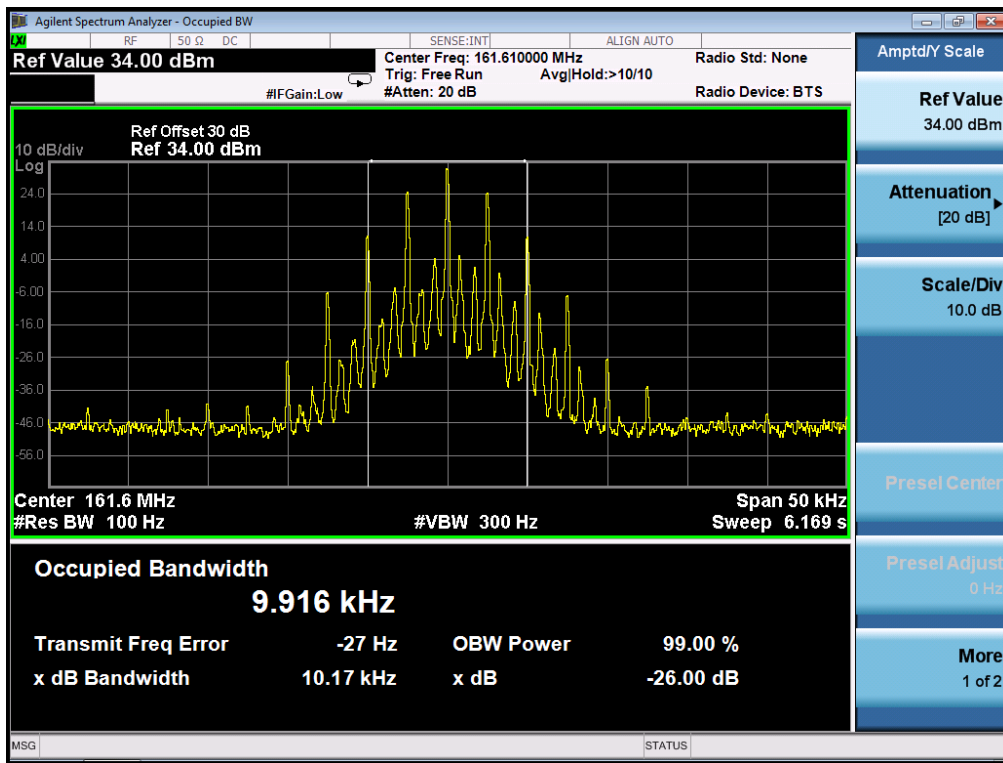

26 dB Bandwidth Measurement Result			
Operating Frequency	12.5 KHz Channel Separation		
	Test Data	Limits	Result
136.025MHz	10.09KHz	11.25 KHz	Pass
151.850MHz	10.13KHz	11.25 KHz	Pass
155.025MHz	10.11KHz	11.25 KHz	Pass
161.61 MHz	10.17KHz	11.25 KHz	Pass
173.975MHz	10.06KHz	11.25 KHz	Pass

Occupied bandwidth of Middle Channel (151.850 MHz)-1W

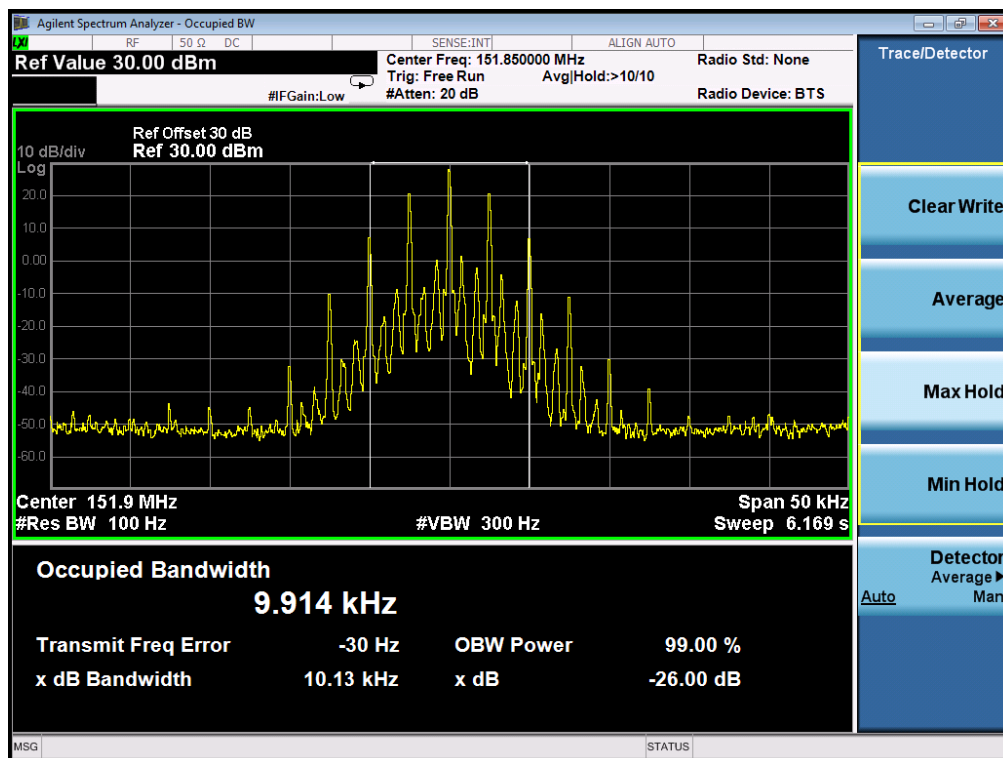

Occupied bandwidth of Middle Channel (161.610 MHz)-1W

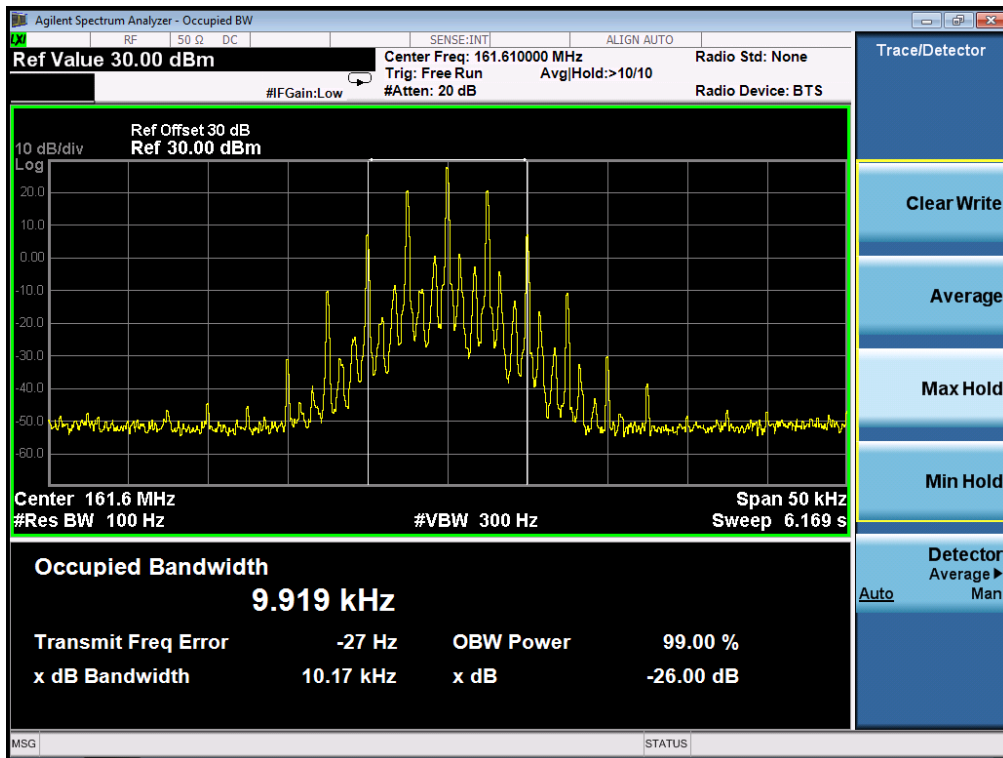

Digital:

TEST RESULTS

26 DB BANDWIDTH MEASUREMENT RESULT			
Operating Frequency	12.5 KHz Channel Separation		
	Test Data	Limits	Result
136.025MHz	8.235KHz	11.25 KHz	Pass
151.850MHz	9.680KHz	11.25 KHz	Pass
155.025MHz	8.369KHz	11.25 KHz	Pass
161.61 MHz	8.412KHz	11.25 KHz	Pass
173.975MHz	8.405KHz	11.25 KHz	Pass

Occupied bandwidth of Middle Channel (151.850 MHz)-10W

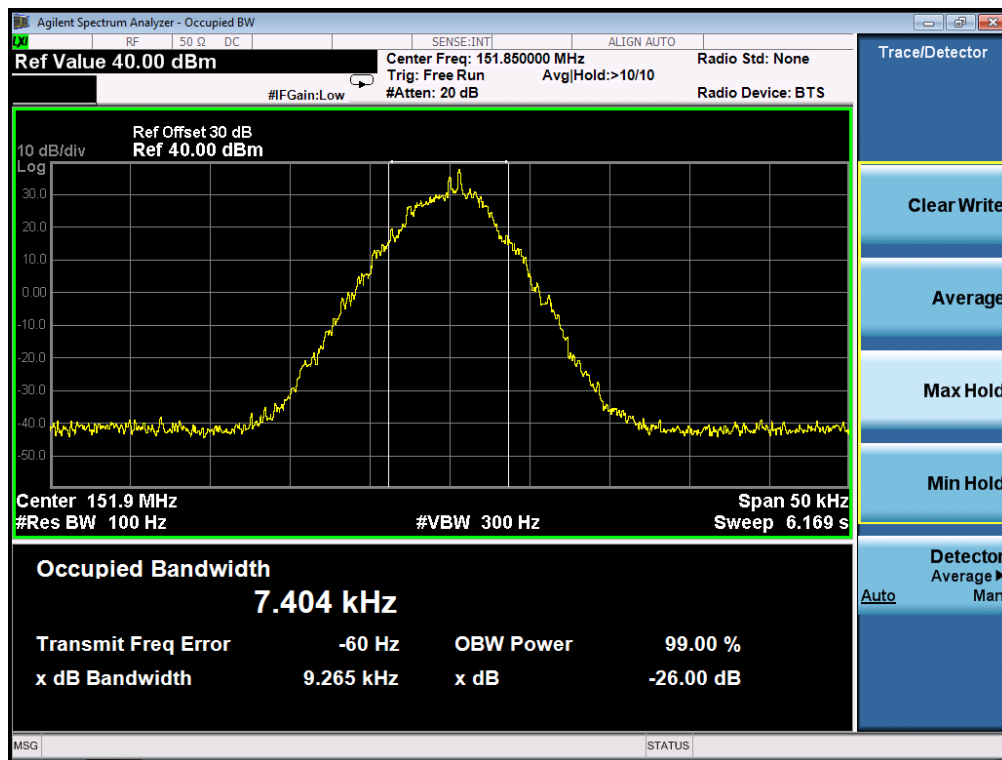

Occupied bandwidth of Middle Channel (161.610 MHz)-10W

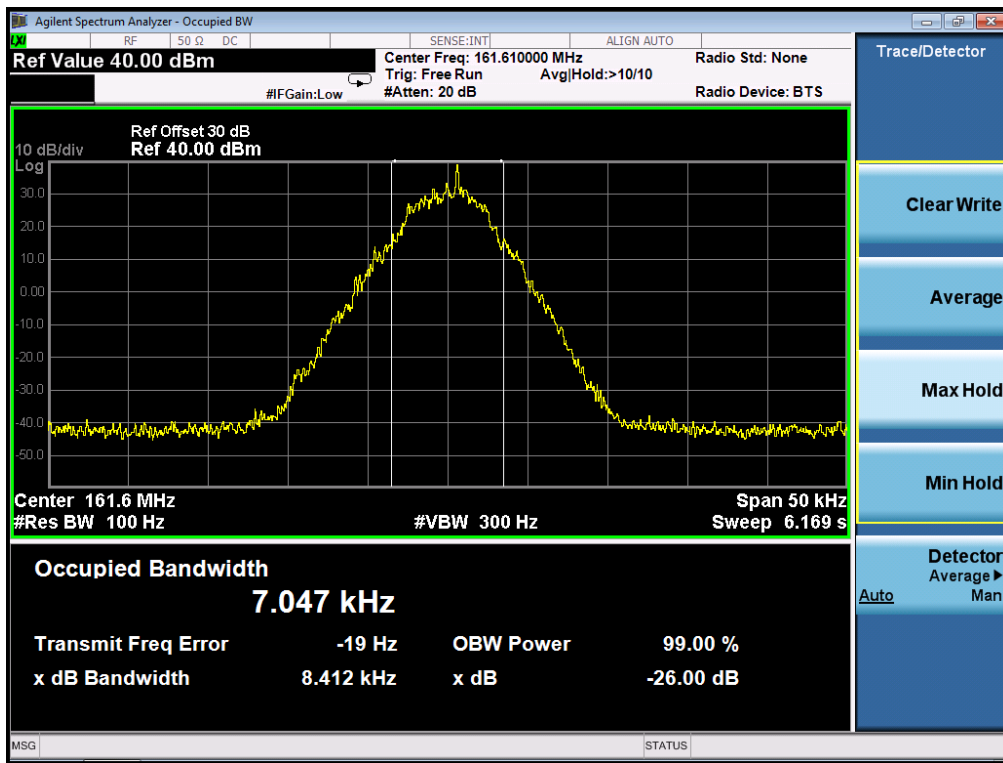

TEST RESULTS

26 DB BANDWIDTH MEASUREMENT RESULT			
Operating Frequency	12.5 KHz Channel Separation		
	Test Data	Limits	Result
136.025MHz	8.053KHz	11.25 KHz	Pass
151.850MHz	8.177KHz	11.25 KHz	Pass
155.025MHz	8.231KHz	11.25 KHz	Pass
161.61 MHz	9.425KHz	11.25 KHz	Pass
173.975MHz	8.092KHz	11.25 KHz	Pass

Occupied bandwidth of Middle Channel (151.850 MHz)-4.5W

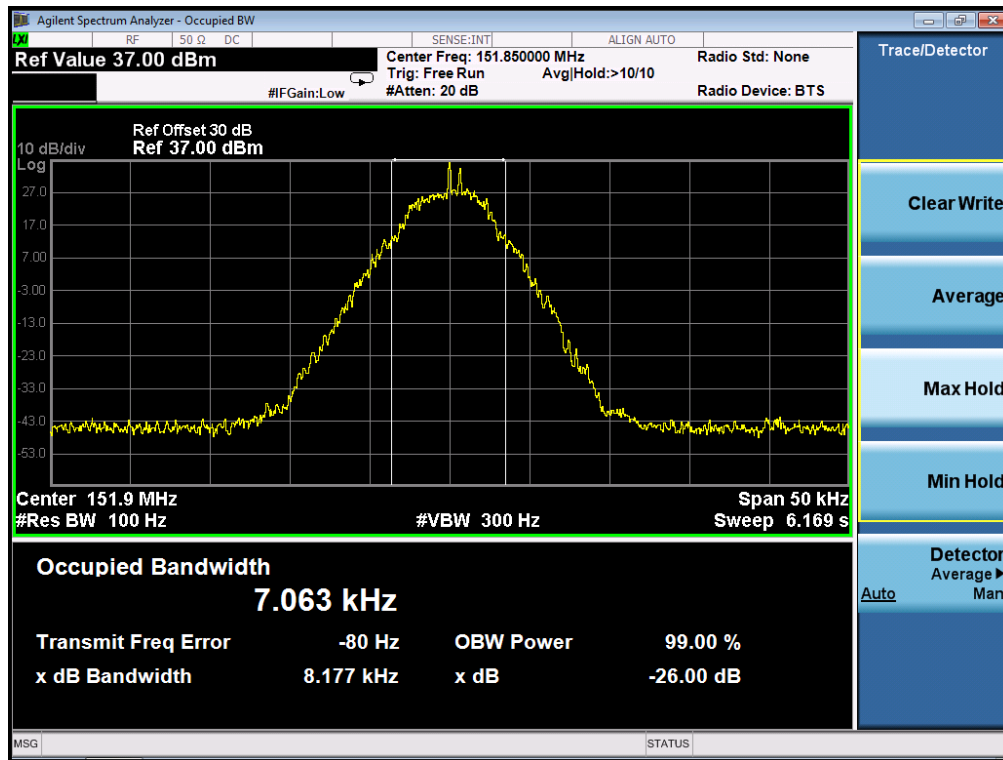

Occupied bandwidth of Middle Channel (161.610 MHz)-4.5W

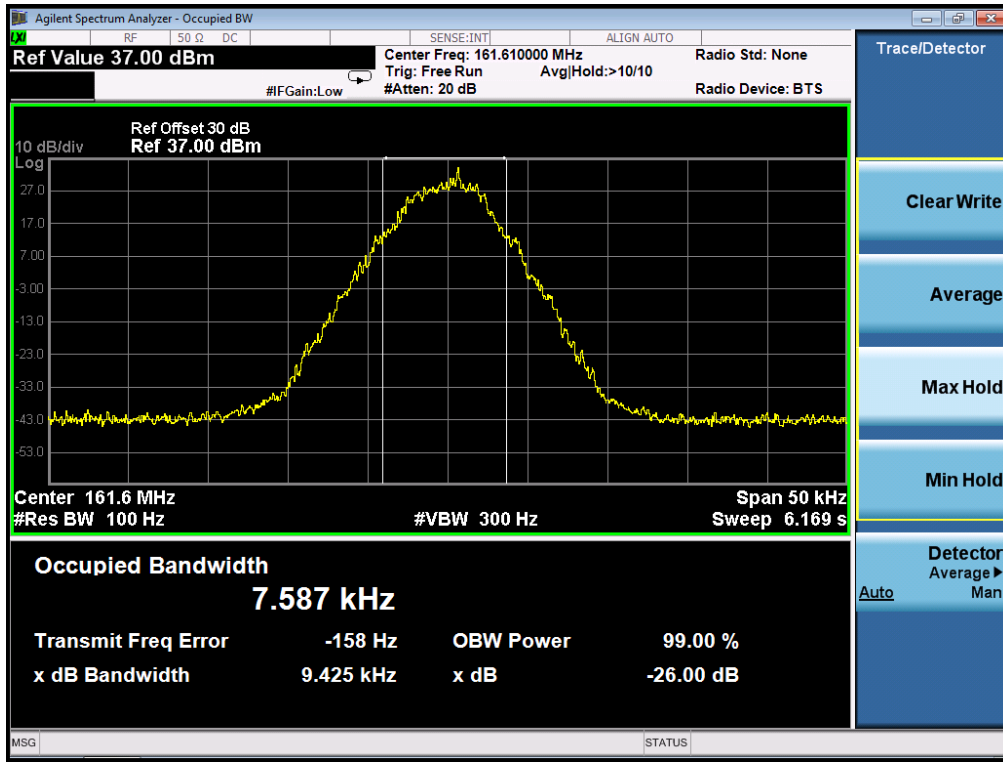

TEST RESULTS

26 DB BANDWIDTH MEASUREMENT RESULT			
Operating Frequency	12.5 KHz Channel Separation		
	Test Data	Limits	Result
136.025MHz	8.659KHz	11.25 KHz	Pass
151.850MHz	8.927KHz	11.25 KHz	Pass
155.025MHz	8.751KHz	11.25 KHz	Pass
161.61 MHz	8.888KHz	11.25 KHz	Pass
173.975MHz	8.618KHz	11.25 KHz	Pass

Occupied bandwidth of Middle Channel (151.850 MHz)-2.5W

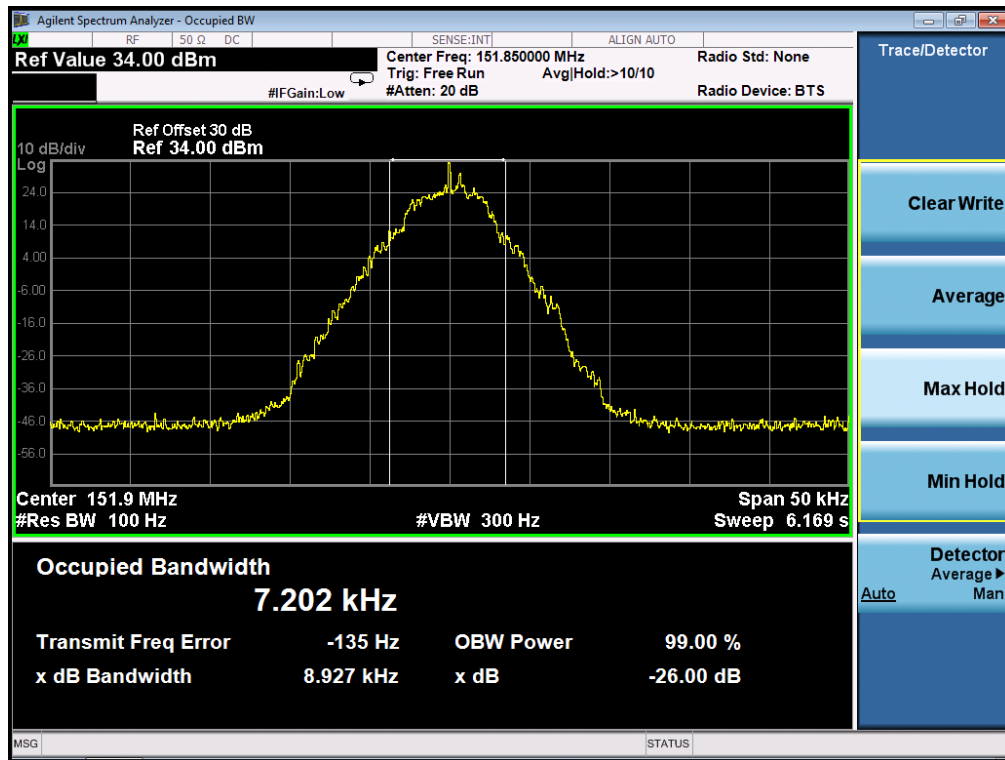

Occupied bandwidth of Middle Channel (161.610 MHz)-2.5W

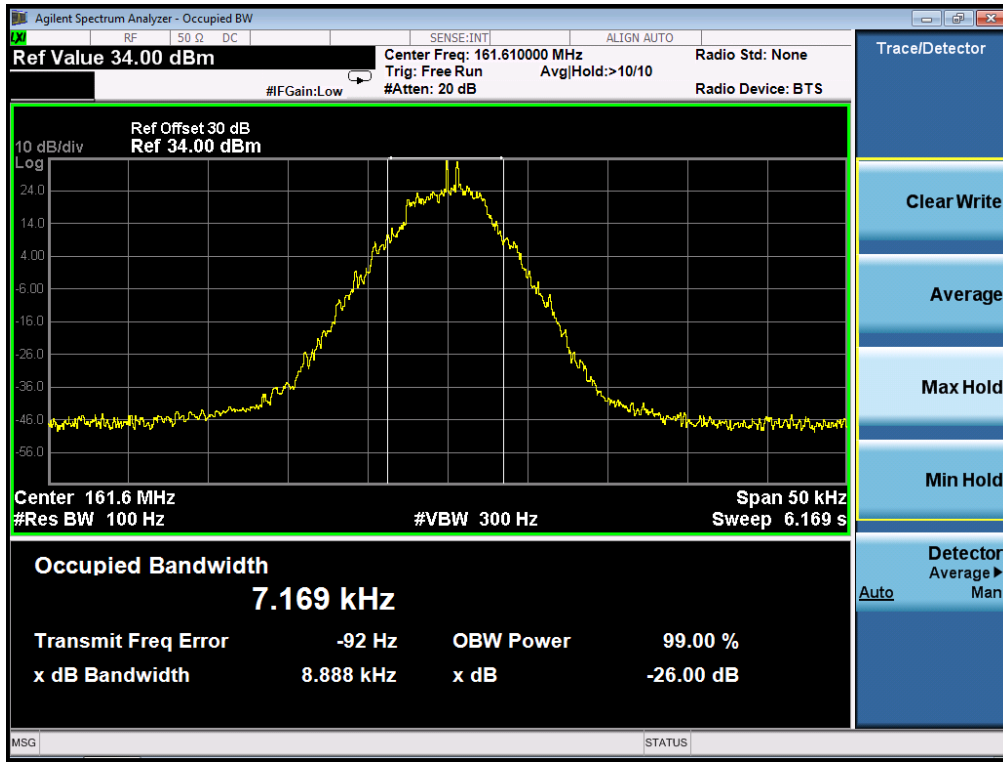

TEST RESULTS

26 DB BANDWIDTH MEASUREMENT RESULT			
Operating Frequency	12.5 KHz Channel Separation		
	Test Data	Limits	Result
136.025MHz	8.405KHz	11.25 KHz	Pass
151.850MHz	8.422KHz	11.25 KHz	Pass
155.025MHz	8.359KHz	11.25 KHz	Pass
161.610MHz	8.865KHz	11.25 KHz	Pass
173.975MHz	8.403KHz	11.25 KHz	Pass

Occupied bandwidth of Middle Channel (151.850 MHz)-1W

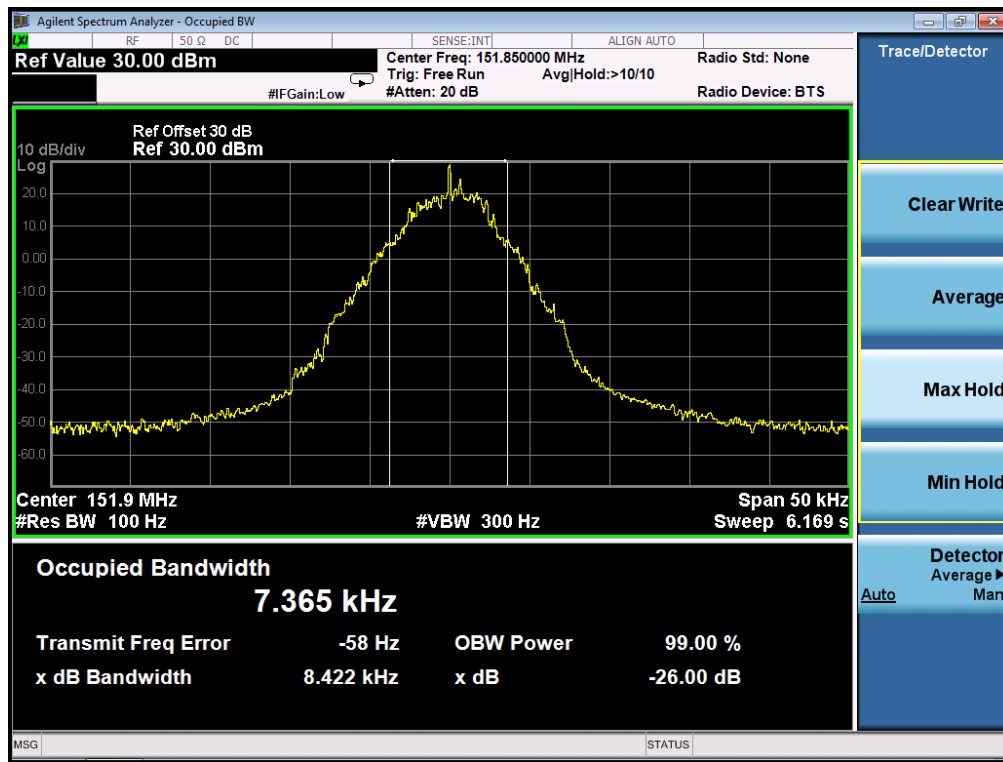

Occupied bandwidth of Middle Channel (161.610 MHz)-1W

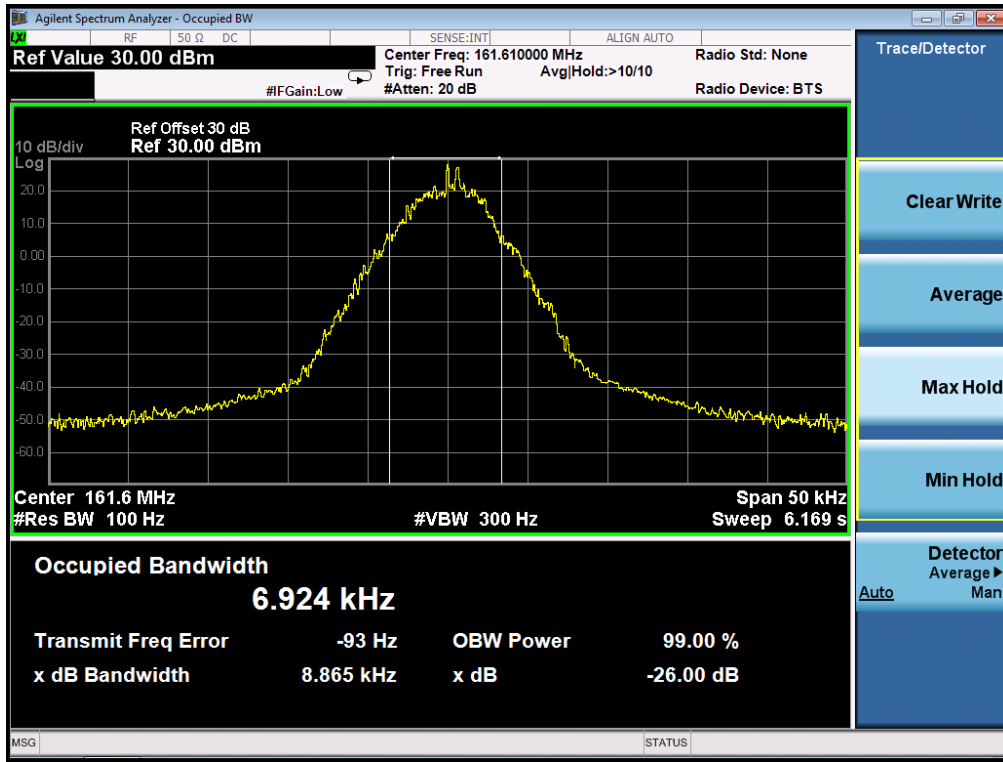

7. UNWANTED RADIATION

7.1 PROVISIONS APPLICABLE

8.1.1 According to FCC §2.1049, §22.359 and §90.210, the power of each unwanted emission shall be less than Transmitted Power as specified below for transmitters designed to operate with each channel separation.

Emission Mask D -for 12.5 KHz Channel Separation:

- (1).On any frequency removed from the center of the authorized bandwidth f_0 to 5.625 KHz removed from f_0 : Zero dB.
- (2).On any frequency removed from the center of the authorized bandwidth by a displacement Frequency (f_d in KHz) f_0 of more than 5.625 KHz but no more than 12.5 KHz: At least $7.27(f_d - 2.88 \text{ KHz})$ dB
- (3).On any frequency removed from the center of the authorized bandwidth by a displacement Frequency (f_d in KHz) f_0 of more than 12.5 KHz: At least $50 + 10 \log(P)$ dB or 70 dB, whichever is lesser attenuation.

7.2 MEASUREMENT PROCEDURE

- (1)On a test site, the EUT shall be placed on a turntable, and in the position closest to the normal use as declared by the user.
- (2)The test antenna shall be oriented initially for vertical polarization located 3m from the EUT to correspond to the transmitter.
- (3)The output of the antenna shall be connected to the measuring receiver and either a peak or quasi-peak detector was used for the measurement as indicated on the report. The detector selection is based on how close the emission level was approaching the limit.
- (4)The transmitter shall be switched on; if possible, without the modulation and the measurement receiver shall be tuned to the frequency of the transmitter under test.
- (5)The test antenna shall be raised and lowered through the specified range of height until the measuring receiver detects a maximum signal level.
- (6)The transmitter shall than be rotated through 360° in the horizontal plane, until the maximum signal level is detected by the measuring receiver.
- (7)The test antenna shall be raised and lowered again through the specified range of height until the measuring receiver detects a maximum signal level.

- (8)The maximum signal level detected by the measuring receiver shall be noted.
- (9)The measurement shall be repeated with the test antenna set to horizontal polarization.
- (10) Replace the antenna with a proper Antenna (substitution antenna).
- (11)The substitution antenna shall be oriented for vertical polarization and, if necessary, the length of the substitution antenna shall be adjusted to correspond to the frequency of transmitting.
- (12)The substitution antenna shall be connected to a calibrated signal generator.
- (13)If necessary, the input attenuator setting of the measuring receiver shall be adjusted in order to

increase the sensitivity of the measuring receiver.

(14) The test antenna shall be raised and lowered through the specified range of the height to ensure that the maximum signal is received.

(15) The input signal to substitution antenna shall be adjusted to the level that produces a level detected by the measuring receiver, that is equal to the level noted while the transmitter radiated power was measured, corrected for the change of input attenuation setting of the measuring receiver.

(16) The input level to the substitution antenna shall be recorded as power level in dBm, corrected for any change of input attenuator setting of the measuring receiver.

(17) The measurement shall be repeated with the test antenna and the substitution antenna oriented for horizontal polarization.

7.3 TEST SETUP BLOCK DIAGRAM

SUBSTITUTION METHOD: (Radiated Emissions)

Radiated Below 1GHz

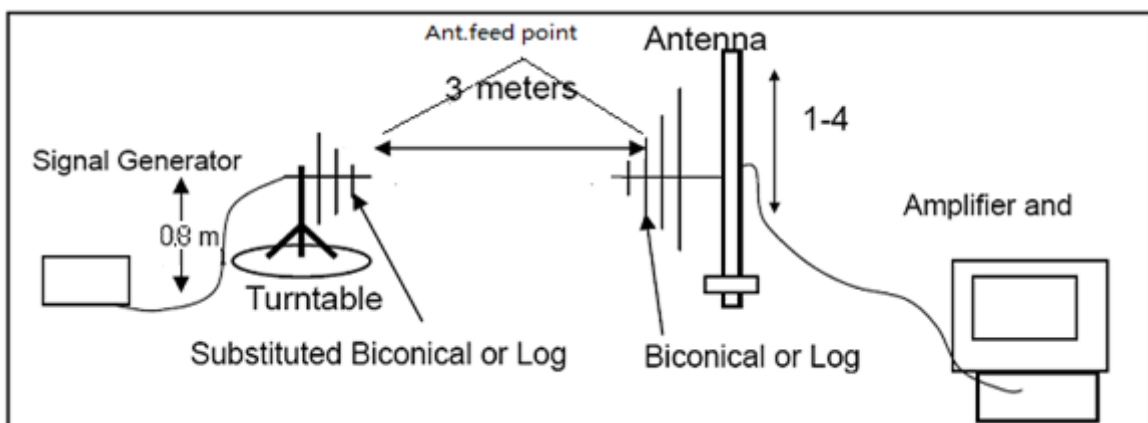
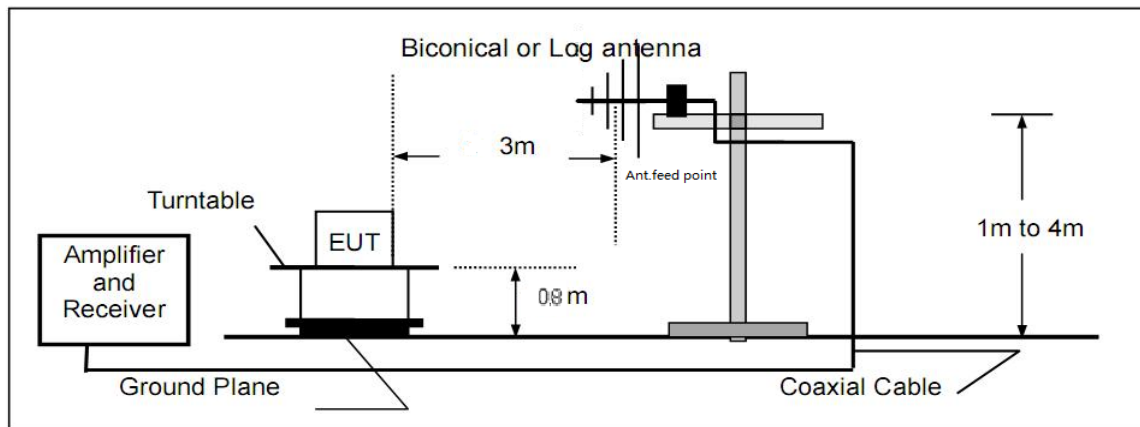

Radiated Above 1 GHz

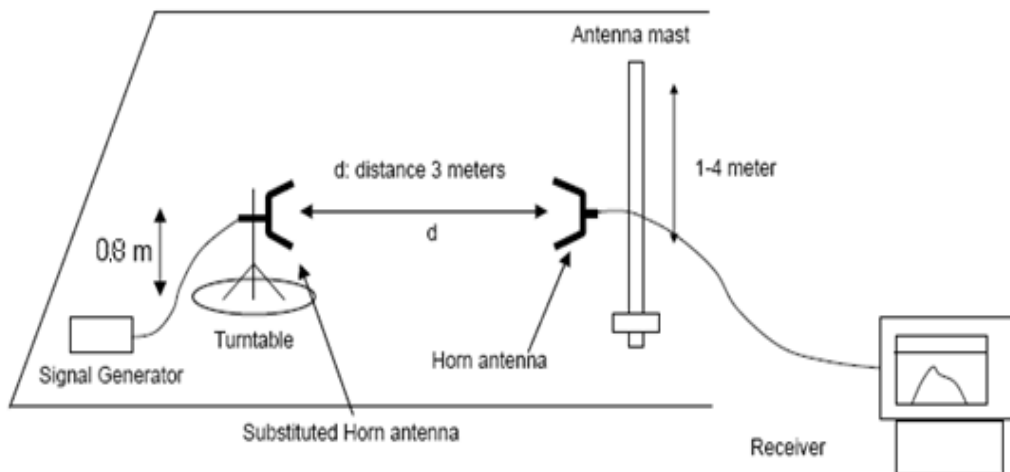
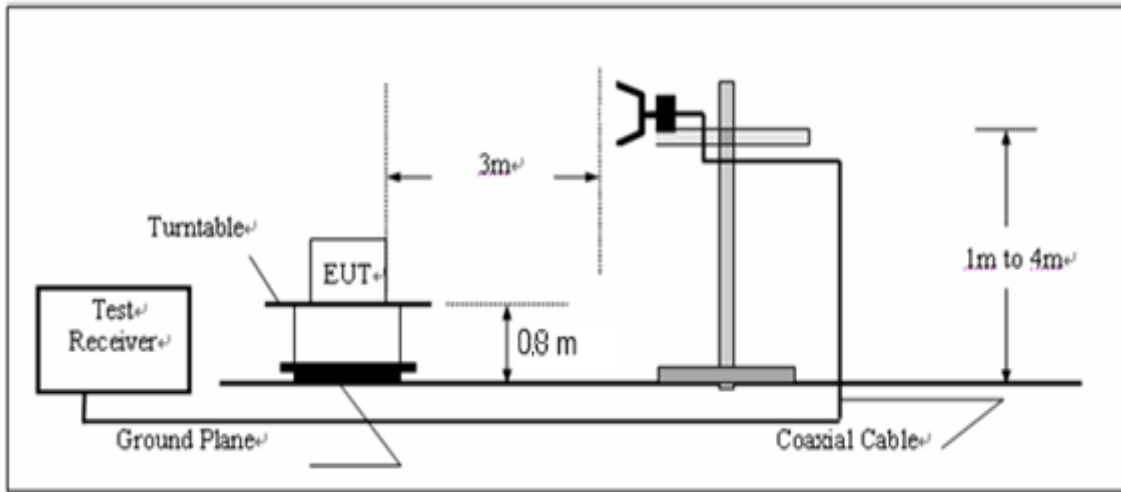

7.4 MEASUREMENT RESULTS:

Applicable Standard

FCC §2.1053, §22.359 and §90.210

On any frequency removed from the center of the authorized bandwidth by a displacement

Frequency (f_d in KHz) for of more than 12.5 KHz: at least $50 + 10 \log(P)$ dB or 70 dB, whichever is lesser attenuation.

Test Procedure

The RF output of the EUT was connected to a spectrum analyzer through appropriate attenuation. The resolution bandwidth of the spectrum analyzer was set at 100 kHz for below 1GHz_{th} and 1MHz for above 1GHz. Sufficient scans were taken to show any out of band emissions up to 10 harmonic.

Limit: At least $50 + 10 \log(P) = 50 + 10 \log(10) = 60$ (dB)—10W

TEST RESULTS -10W:

Transmitter Spurious Emission (30MHz-2GHz)

Frequency	Reading Level	Antenna	S.G.	Cable Loss	Ant.Gain	Emission Level	Limit	Margin
(MHz)	(dBuV/m)	Polarization	(dBm)	(dB)	(dBi)	(dBm)	(dBm)	(dB)
Analog Modulation 151.85MHz—part 90								
303.7	42.05	V	-55.61	0.19	7.03	-48.77	-20.00	28.77
303.7	41.26	H	-56.72	0.19	7.03	-49.88	-20.00	29.88
1062.95	47.59	H	-47.95	0.81	5.34	-43.41	-20.00	23.41
1062.95	48.24	V	-48.49	0.81	5.34	-43.96	-20.00	23.96
Analog Modulation 161.61MHz—part 22								
323.22	41.95	H	-57.01	0.21	6.10	-51.13	-13.00	38.13
323.22	42.35	V	-53.86	0.21	6.10	-47.97	-13.00	34.97
1131.27	48.32	H	-48.93	0.85	5.40	-44.38	-13.00	31.38
1131.27	49.37	V	-44.76	0.85	5.40	-40.21	-13.00	27.21
Digital Modulation 151.85MHz—part 90								
303.7	40.08	H	-59.14	0.19	7.03	-52.30	-20.00	32.30
303.7	42.19	V	-56.92	0.19	7.03	-50.08	-20.00	30.08
1062.95	45.91	V	-48.10	0.81	5.34	-43.56	-20.00	23.56
1062.95	45.83	H	-48.03	0.81	5.34	-43.50	-20.00	23.50
Digital Modulation 161.61MHz—part 22								
323.22	41.19	H	-57.87	0.21	6.10	-51.98	-13.00	38.98
323.22	41.42	V	-55.44	0.21	6.10	-49.56	-13.00	36.56
1131.27	48.59	H	-47.06	0.85	5.40	-42.51	-13.00	29.51
1131.27	46.53	V	-48.95	0.85	5.40	-44.40	-13.00	31.40

Note: All the test frequencies was tested, but only the worst data be recorded in this part.

The Worst Emission Mask for (161.61MHz) of 12.5 KHz channel Separation (10W)

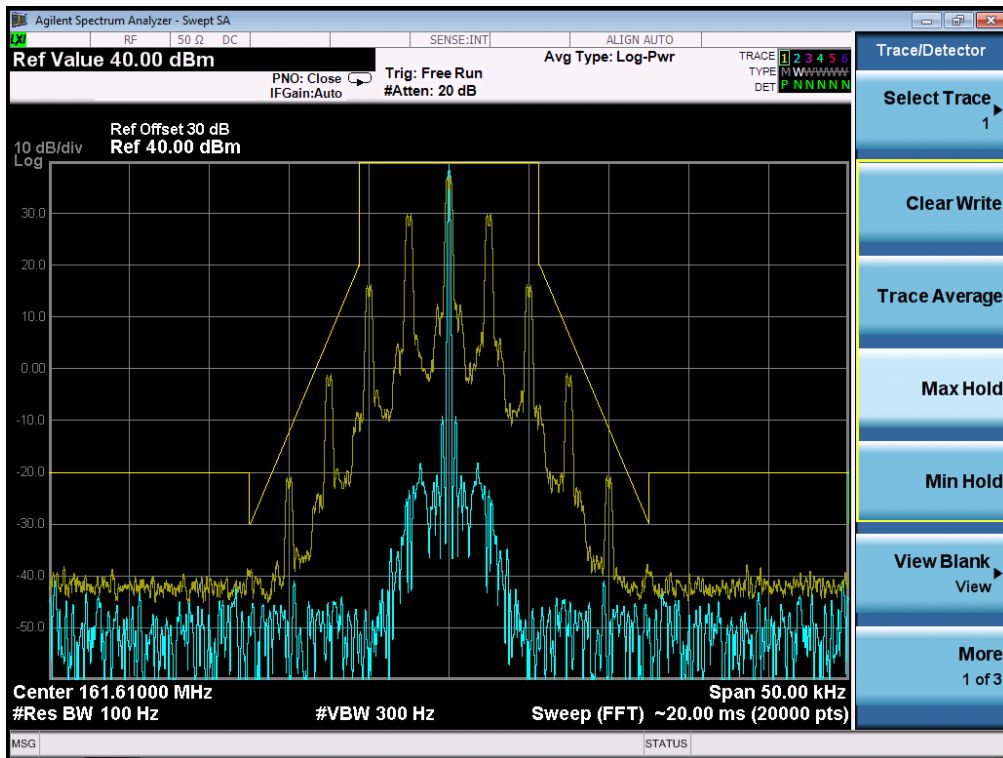

The Worst Emission Mask D for 12.5 KHz channel Separation-151.85MHz (4.5W)

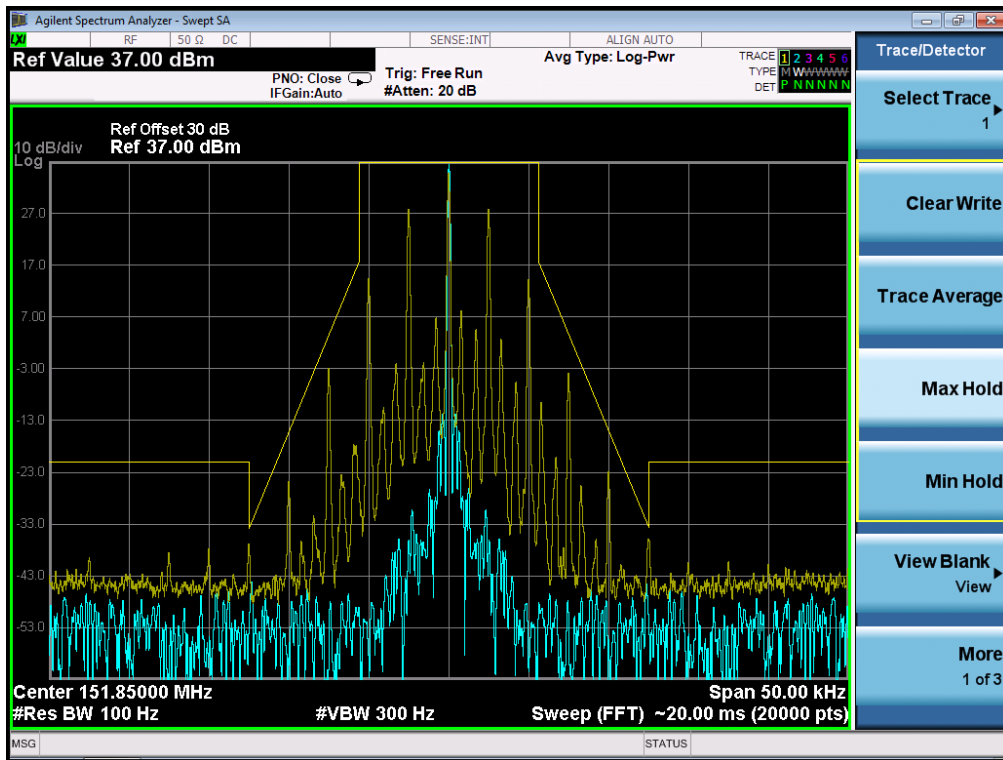

The Worst Emission Mask for (161.61MHz) of 12.5 KHz channel Separation (4.5W)

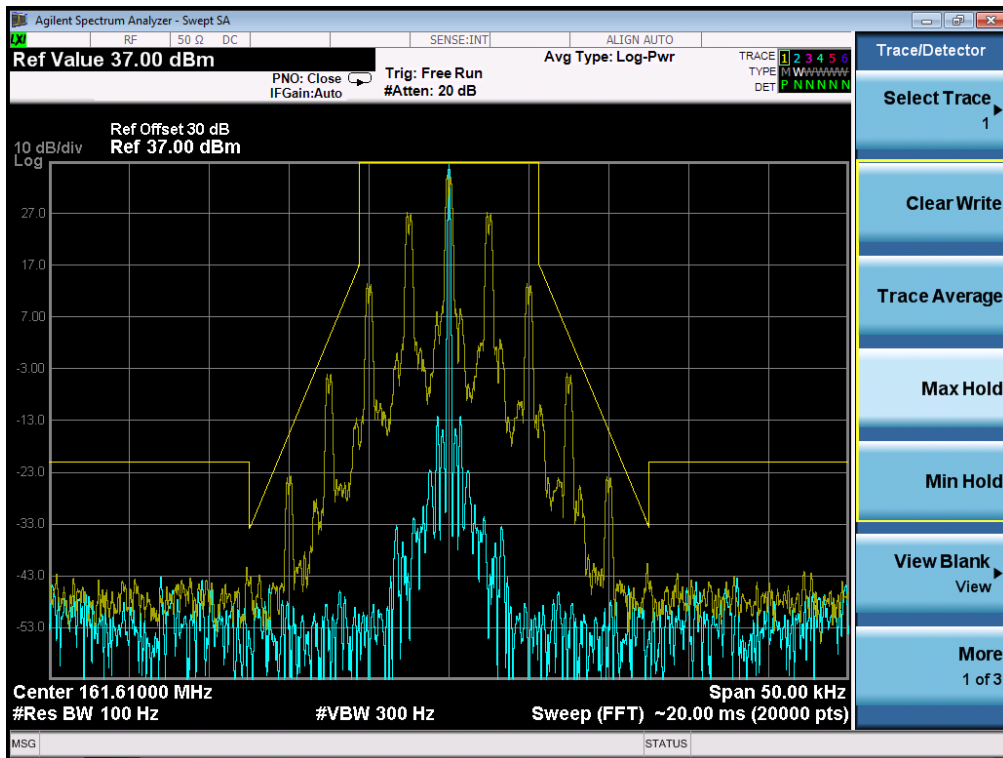

The Worst Emission Mask D for 12.5 KHz channel Separation-151.85MHz (2.5W)

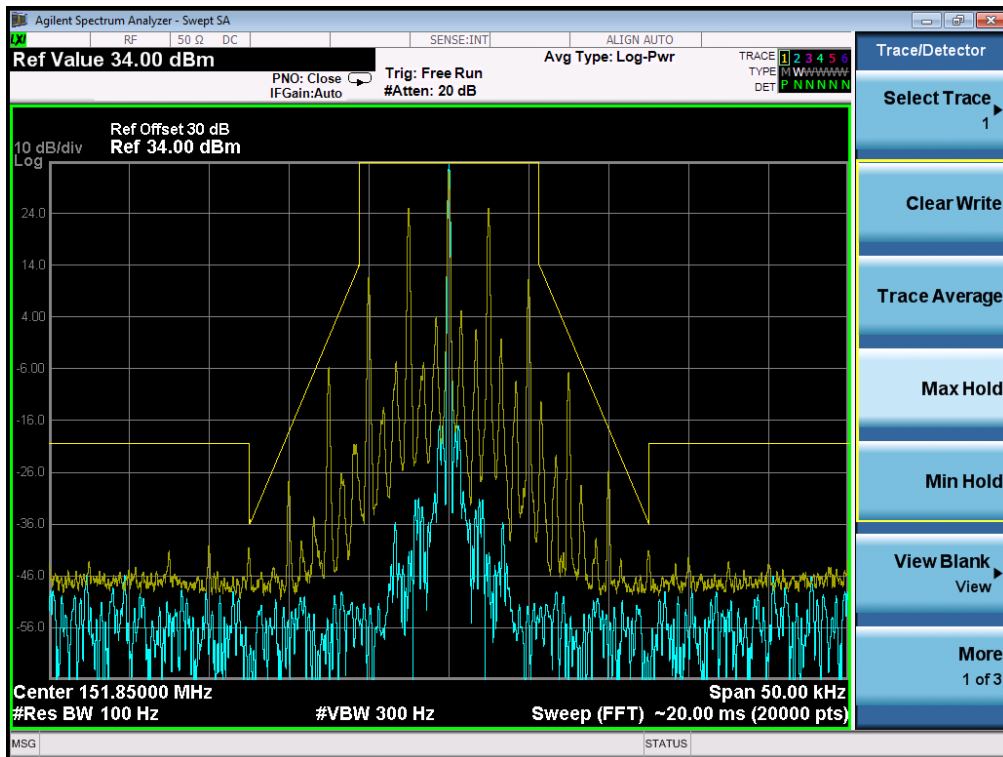

The Worst Emission Mask D for 12.5 KHz channel Separation-161.61MHz (2.5W)

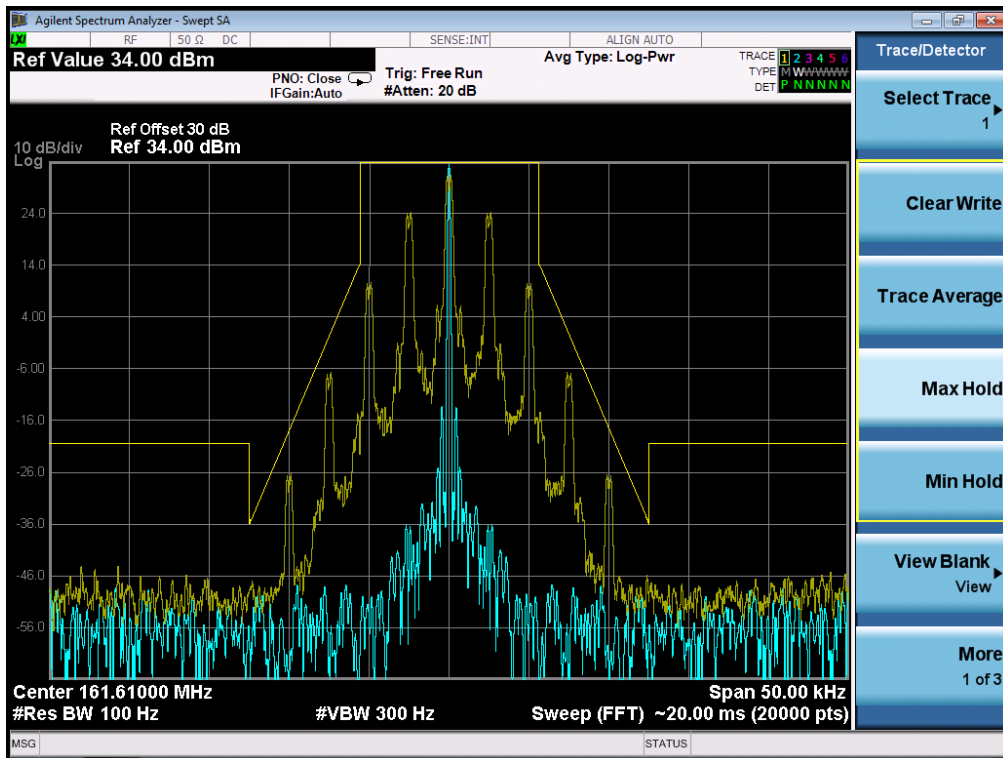

The Worst Emission Mask D for 12.5 KHz channel Separation-151.85MHz (1W)

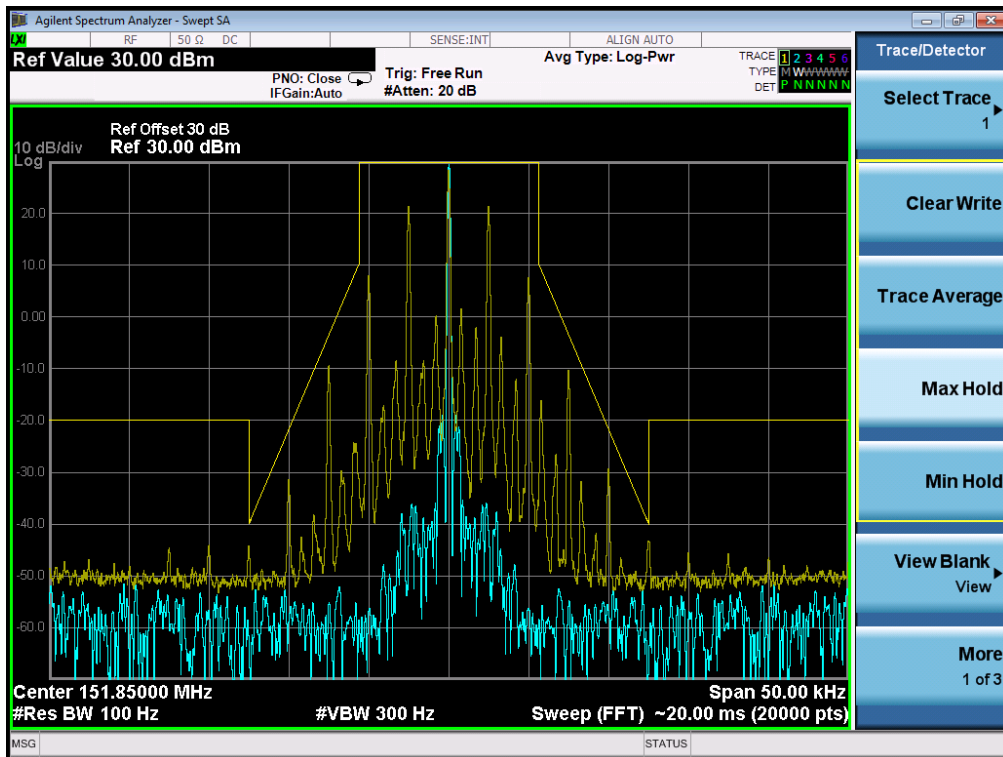

The Worst Emission Mask D for 12.5 KHz channel Separation-161.61MHz (1W)

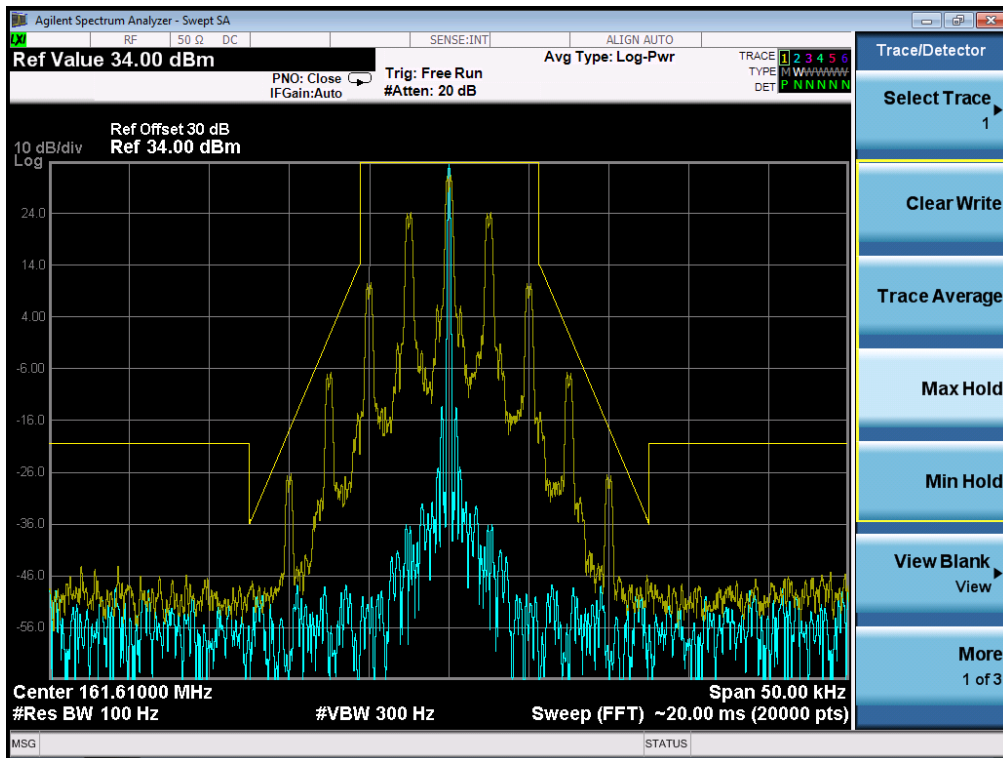

Digital:

The Worst Emission Mask D for 12.5 KHz channel Separation-151.85MHz (10W)

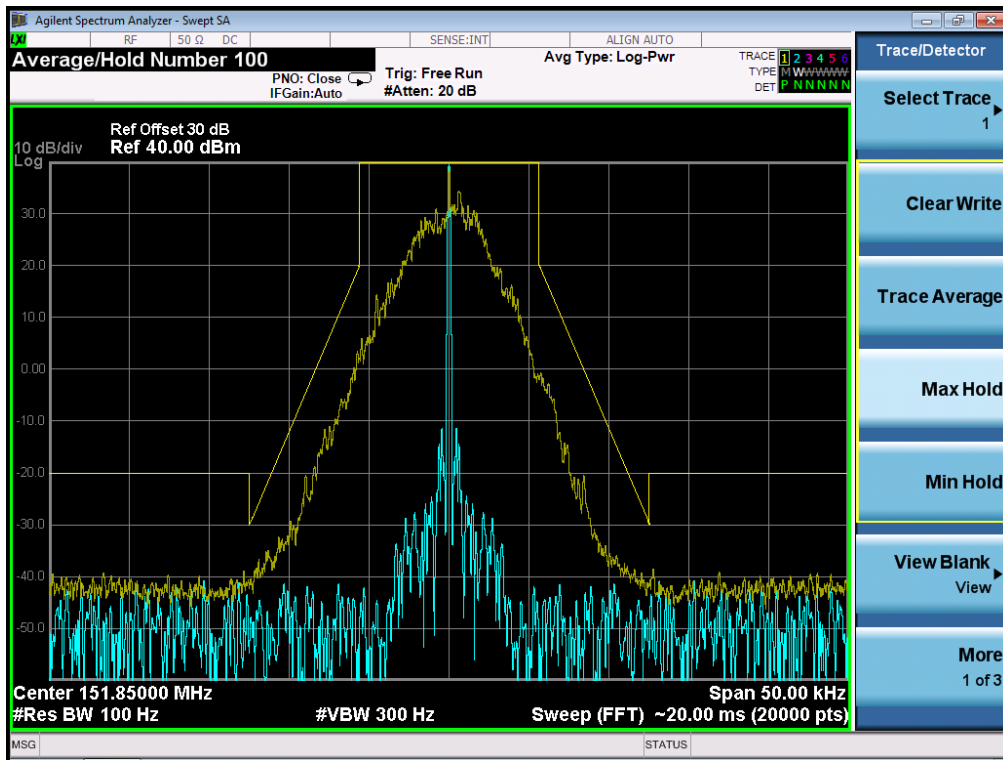

The Worst Emission Mask D for 12.5 KHz channel Separation-161.61MHz (10W)

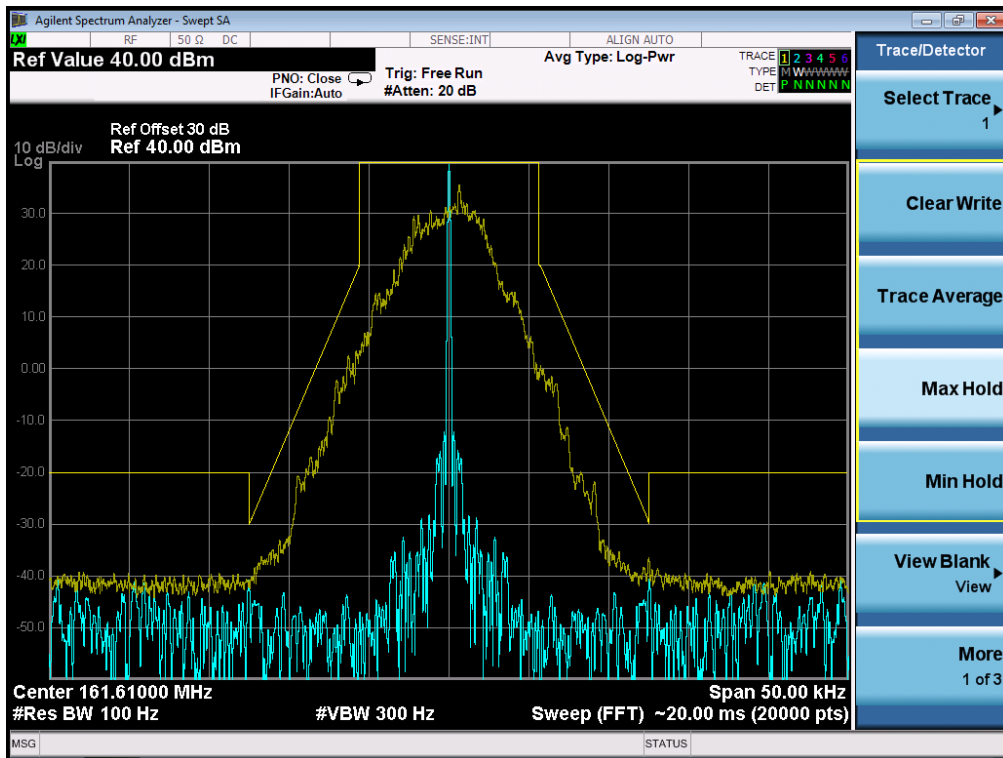

The Worst Emission Mask D for 12.5 KHz channel Separation-151.85MHz (4.5W)

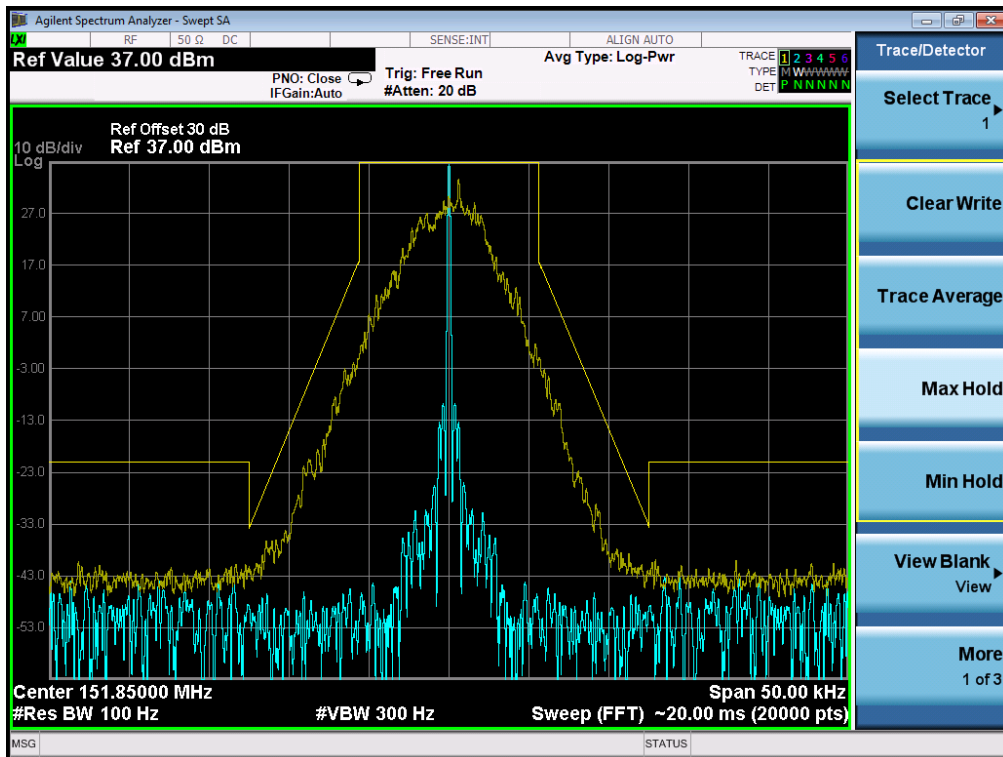

The Worst Emission Mask for (161.61MHz) of 12.5 KHz channel Separation (4.5W)

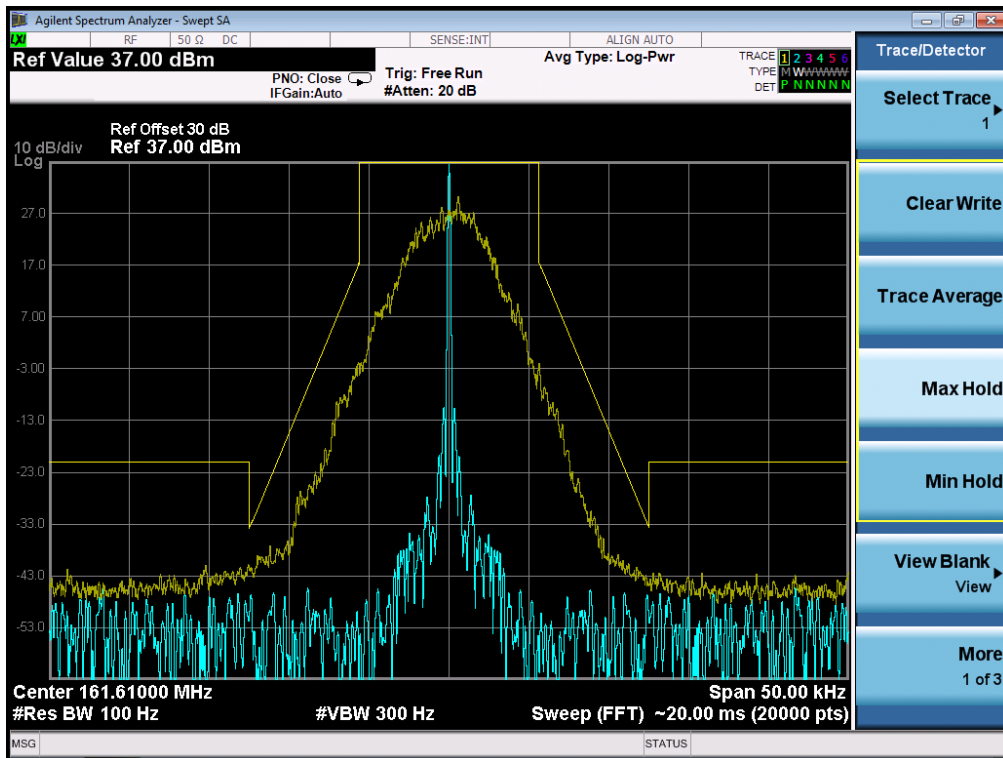

The Worst Emission Mask D for 12.5 KHz channel Separation-151.85MHz (2.5W)

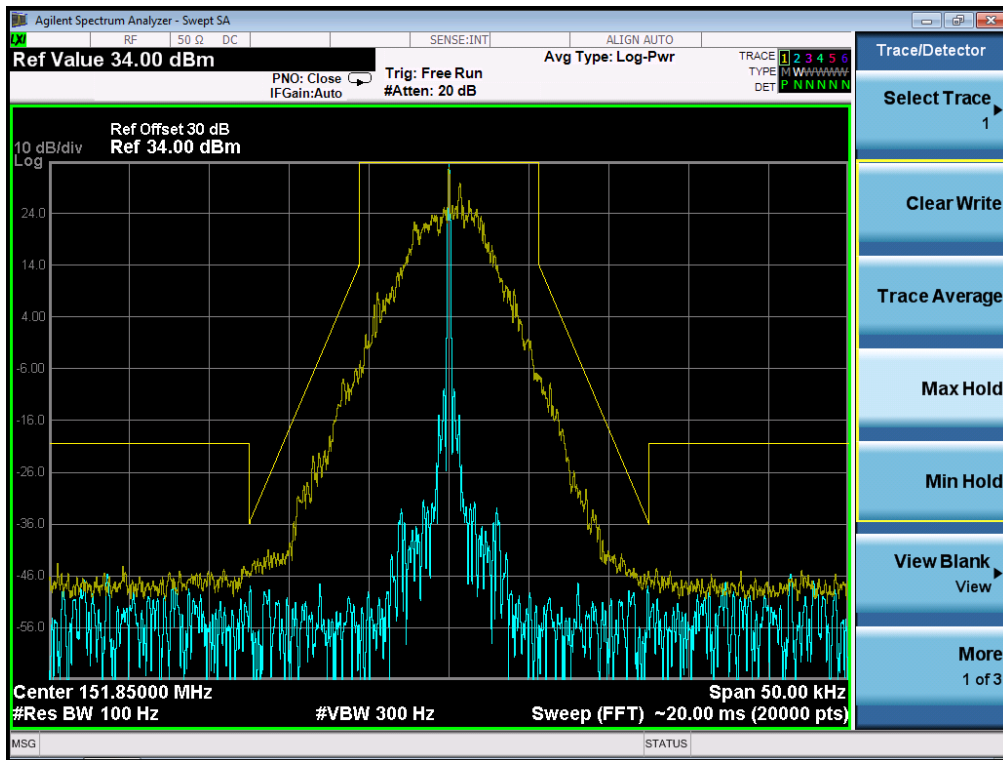

The Worst Emission Mask D for 12.5 KHz channel Separation-161.61MHz (2.5W)

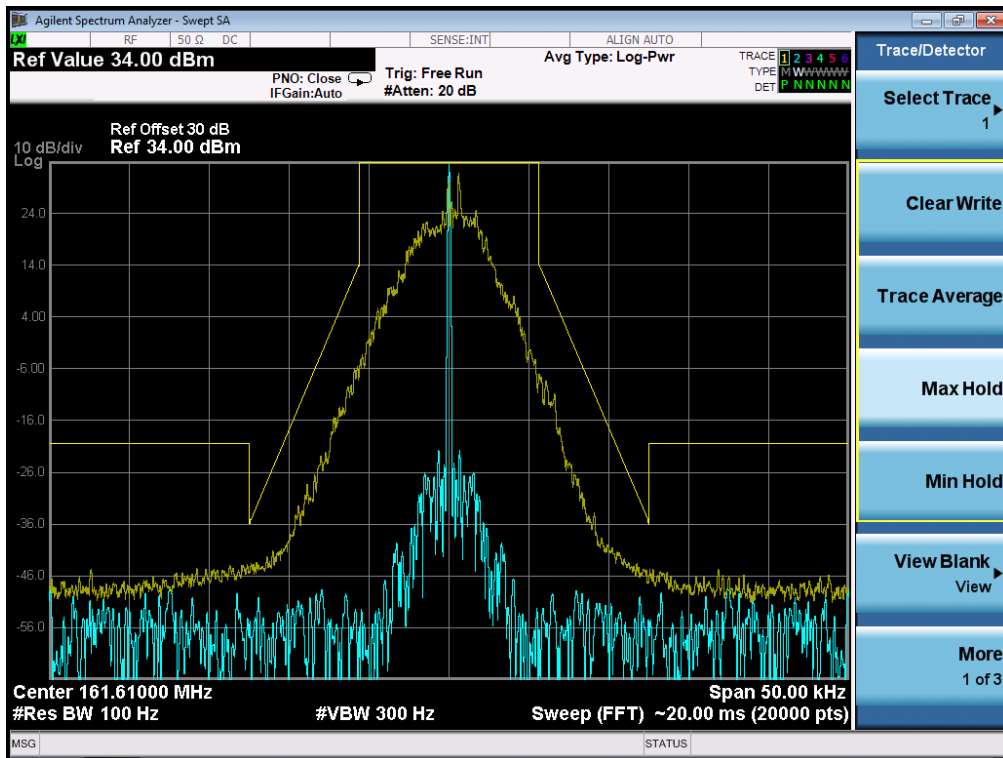

The Worst Emission Mask D for 12.5 KHz channel Separation-151.85MHz (1W)

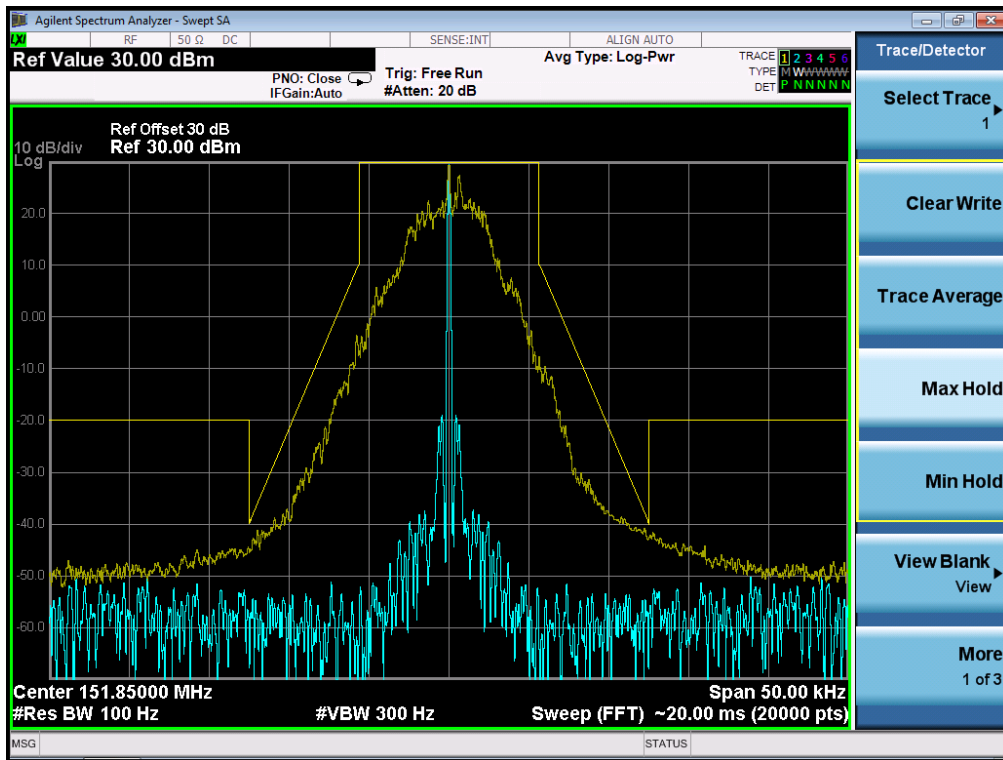

The Worst Emission Mask D for 12.5 KHz channel Separation-161.61MHz (1W)

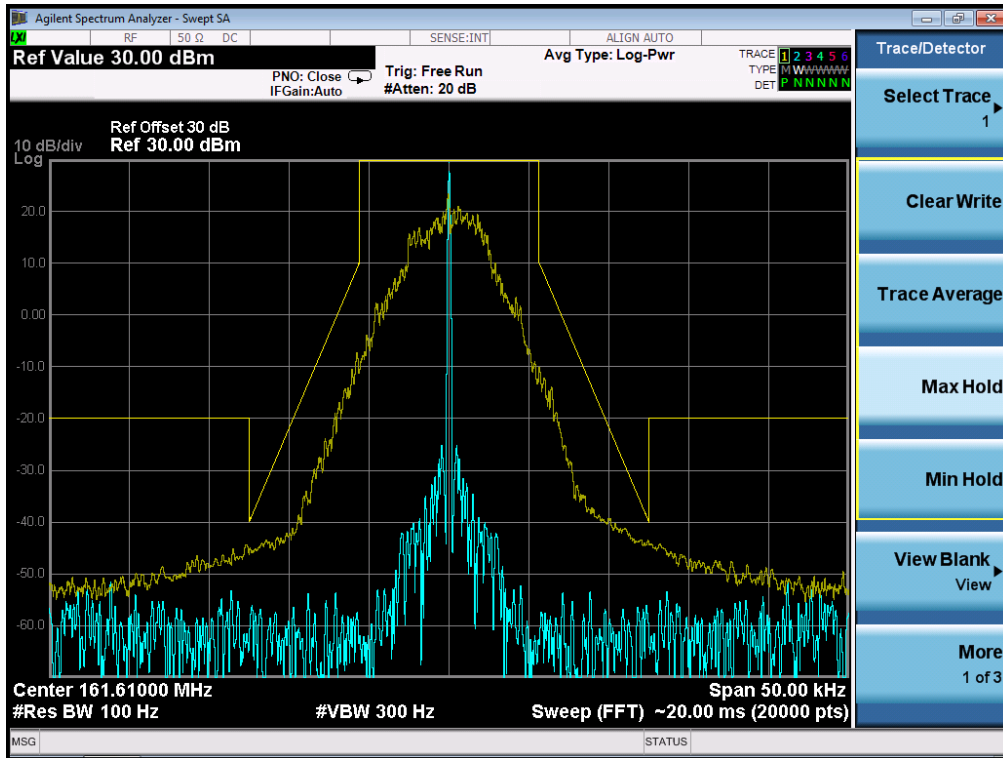

8. MODULATION CHARACTERISTICS

8.1 PROVISIONS APPLICABLE

According to FCC§2.1047 and §90.207, for Voice Modulation Communication Equipment, the frequency response of the audio modulation circuit over a range of 100 to 5000Hz shall be measured.

8.2 MEASUREMENT METHOD

8.2.1 Modulation Limit

- (1). Configure the EUT as shown in figure 1, adjust the audio input for 60% of rated system deviation at 1KHz using this level as a reference (0dB) and vary the input level from -20 to +20dB. Record the frequency deviation obtained as a function of the input level.
- (2). Repeat step 1 with input frequency changing to 300, 1000, 1500 and 3000Hz in sequence.

8.2.2 Audio Frequency Response

- (1). Configure the EUT as shown in figure 1.
- (2). Adjust the audio input for 20% of rated system deviation at 1 KHz using this level as a reference (0 dB).
- (3). Vary the Audio frequency from 100 Hz to 10 KHz and record the frequency deviation.
- (4). Audio Frequency Response = $20\log_{10}(\text{Deviation of test frequency}/\text{Deviation of 1 KHz reference})$.

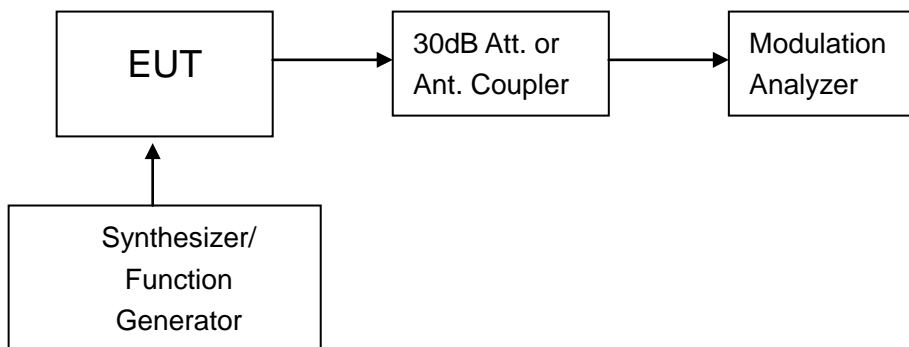

Figure 1: Modulation characteristic measurement configuration

8.3 MEASUREMENT RESULT

Analog:

VHF-10W:

(A). MODULATION LIMIT:

Bottom Channel @ 12.5 KHz Channel Separations

Modulation Level (dB)	Peak Freq. Deviation At 300 Hz	Peak Freq. Deviation At 1000 Hz	Peak Freq. Deviation At 1500 Hz	Peak Freq. Deviation At 3000 Hz
-20	0.15	0.63	0.85	0.89
-15	0.29	0.85	0.97	1.06
-10	0.43	0.92	1.22	1.34
-5	0.49	1.14	1.43	1.47
0	0.58	1.29	1.52	1.62
+5	0.68	1.48	1.74	1.81
+10	0.71	1.53	1.80	1.94
+15	0.92	1.64	1.72	1.83
+20	0.88	1.58	1.64	1.82

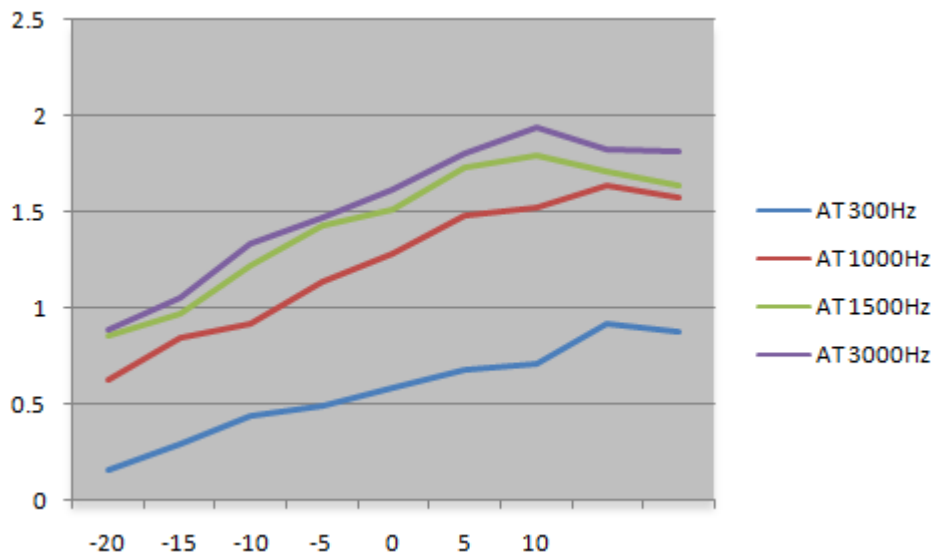

Note: All the modes had been tested, but only the worst data recorded in the report.

(B). AUDIO FREQUENCY RESPONSE:

Bottom Channel @ 12.5 KHz Channel Separations

Frequency (Hz)	Deviation (KHz)	Audio Frequency Response(dB)
100	--	--
200	--	--
300	0.10	-13.98
400	0.14	-11.06
500	0.18	-8.87
600	0.23	-6.74
700	0.24	-6.38
800	0.30	-4.44
900	0.38	-2.38
1000	0.52	0.34
1200	0.51	0.17
1400	0.63	2.01
1600	0.74	3.41
1800	0.82	4.30
2000	0.94	5.48
2400	1.21	7.68
2500	1.45	9.25
2800	1.65	10.37
3000	1.74	10.83
3200	1.75	10.88
3600	1.51	9.60
4000	0.85	4.61
4500	0.81	4.19
5000	0.59	1.44
5500	0.45	-0.92
6000	0.17	-9.37
6500	0.04	-21.94
7000	0.03	-24.44
7500	0.01	-33.98
9000	--	--
10000	--	--
14000	--	--
18000	--	--
20000	--	--
30000	--	--

Frequency Response of Bottom Channel

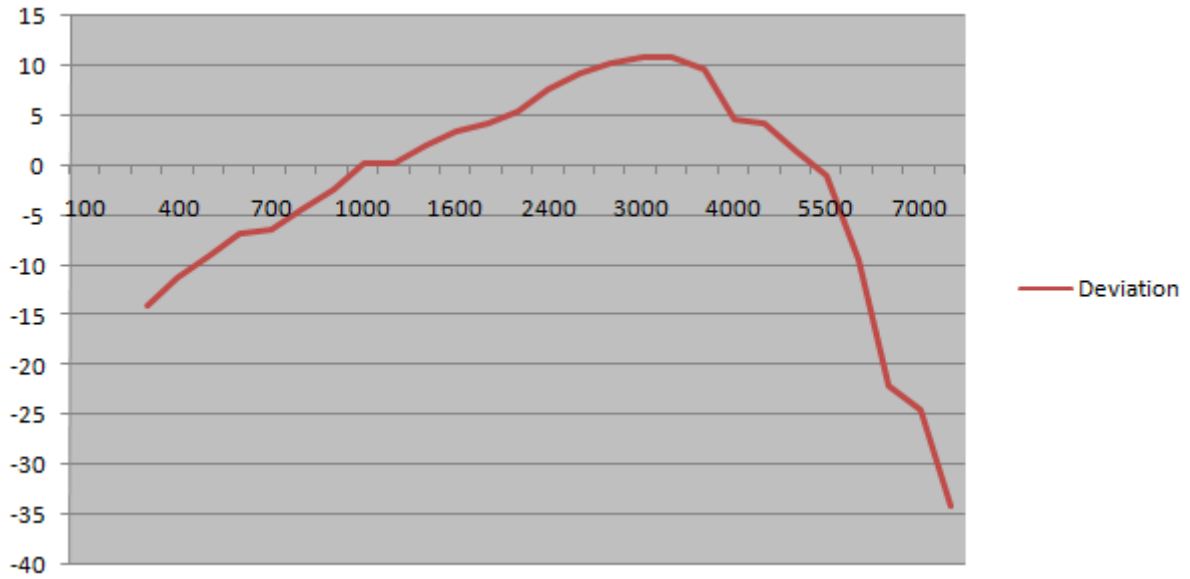

Note: All the modes had been tested, but only the worst data recorded in the report.

Digital:
VHF-10W

(A). MODULATION LIMIT:

Middle Channel @ 12.5 KHz Channel Separations

Modulation Level (dB)	Peak Freq. Deviation At 300 Hz	Peak Freq. Deviation At 1000 Hz	Peak Freq. Deviation At 1500 Hz	Peak Freq. Deviation At 3000 Hz
-20	0.11	0.64	0.74	0.86
-15	0.26	0.73	0.86	0.92
-10	0.37	1.05	1.14	1.24
-5	0.39	1.28	1.32	1.32
0	0.49	1.29	1.52	1.55
+5	0.72	1.52	1.68	1.73
+10	0.81	1.71	1.75	1.88
+15	0.89	1.68	1.73	1.95
+20	0.91	1.66	1.69	1.91

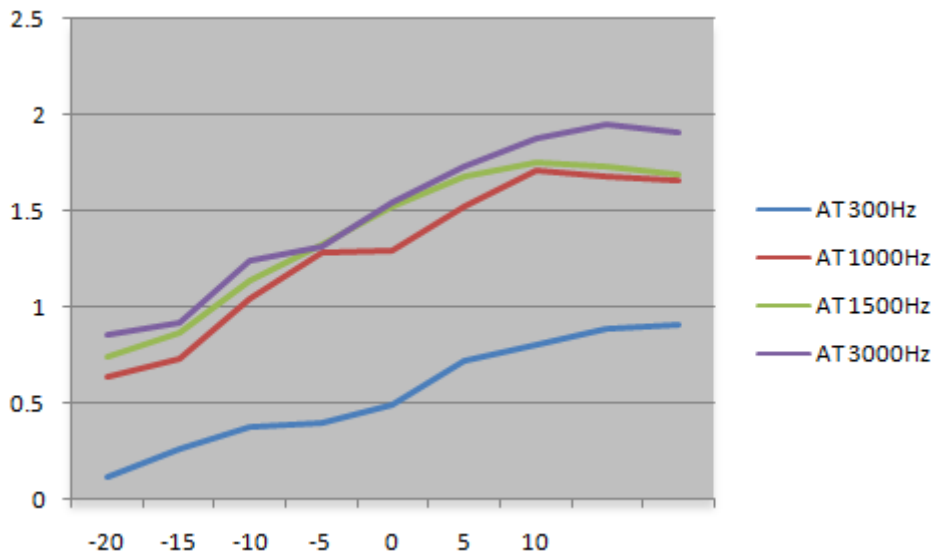

Note: All the modes had been tested, but only the worst data recorded in the report.

(B). AUDIO FREQUENCY RESPONSE:

Middle Channel @ 12.5 KHz Channel Separations

Frequency (Hz)	Deviation (KHz)	Audio Frequency Response(dB)
100	--	--
200	--	--
300	0.05	-20.00
400	0.13	-11.70
500	0.22	-7.13
600	0.23	-6.74
700	0.26	-5.68
800	0.35	-3.10
900	0.44	-1.11
1000	0.52	0.34
1200	0.58	1.29
1400	0.65	2.28
1600	0.75	3.52
1800	0.85	4.61
2000	0.94	5.48
2400	1.21	7.68
2500	1.48	9.43
2800	1.66	10.42
3000	1.75	10.88
3200	1.72	10.73
3600	1.51	9.60
4000	1.00	6.02
4500	0.83	4.40
5000	0.71	3.05
5500	0.48	-0.35
6000	0.18	-8.87
6500	0.06	-18.42
7000	0.04	-21.94
7500	0.01	-33.98
9000	--	--
10000	--	--
14000	--	--
18000	--	--
20000	--	--
30000	--	--

Frequency Response of Middle Channel

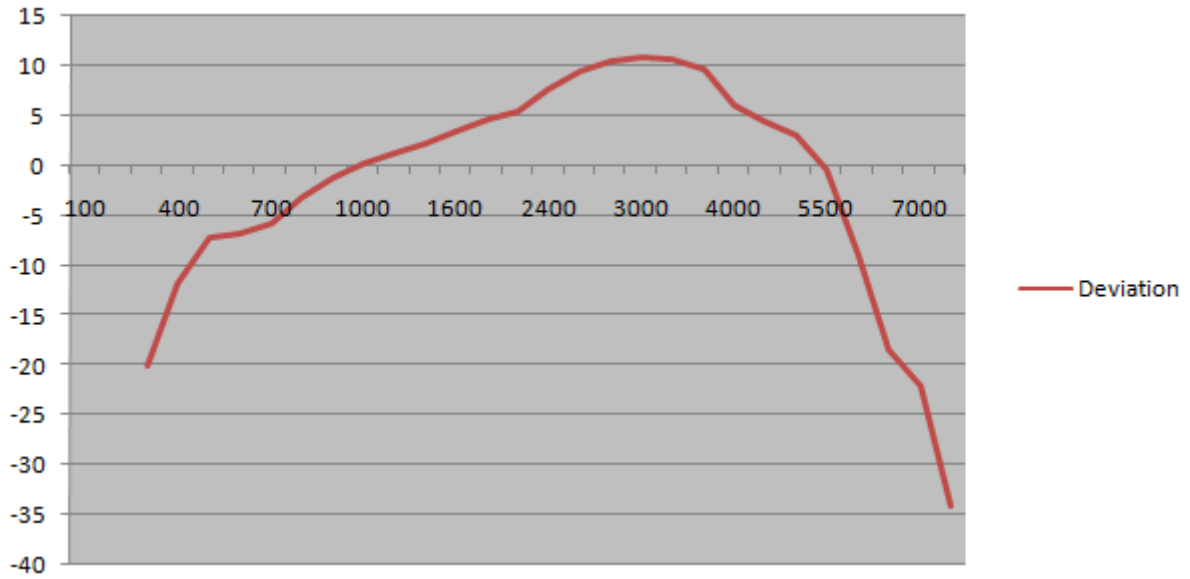

Note: All the modes had been tested, but only the worst data recorded in the report.

9. MAXIMUM TRANSMITTER POWER (CONDUCTED OUTPUT POWER)

9.1 PROVISIONS APPLICABLE

Per FCC §2.1046 § 22.565 and §90.205: Maximum ERP is dependent upon the station's antenna HAAT and required service area.

9.2 TEST PROCEDURE

The RF output of Two-way Radio was conducted to a spectrum analyzer through an appropriate attenuator.

9.3 TEST CONFIGURATION

Conducted Output Power:

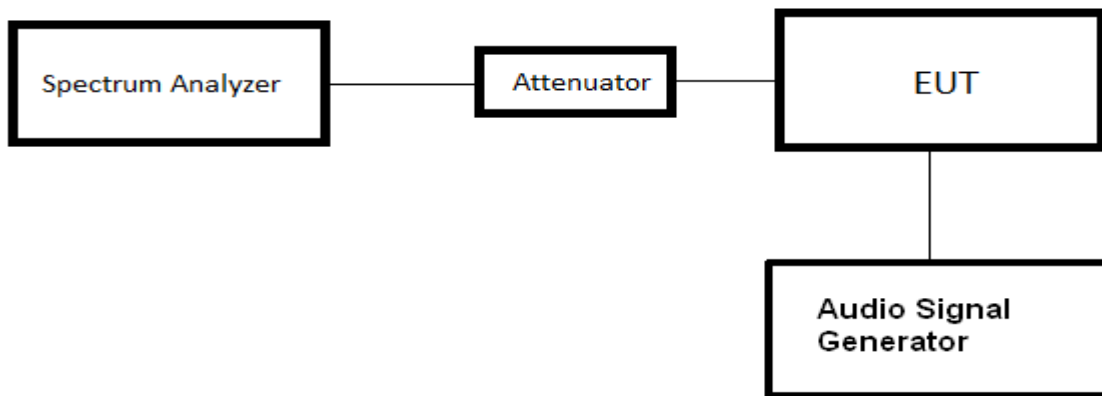

Effective Radiated Power

Radiated Below 1GHz

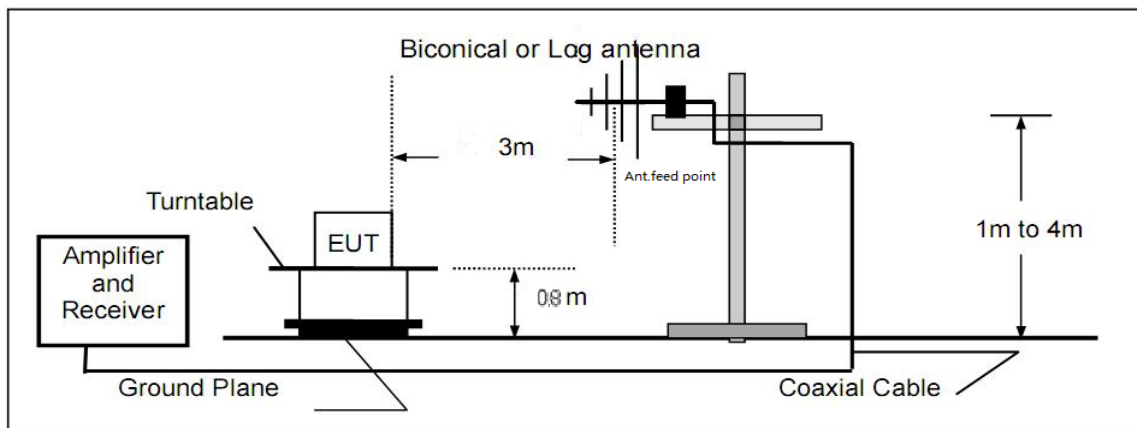

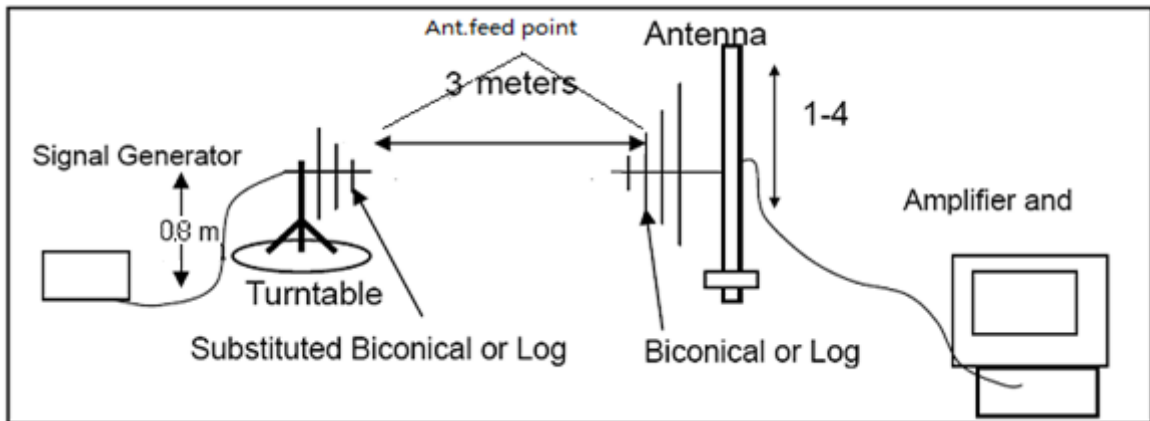

Radiated Above 1 GHz

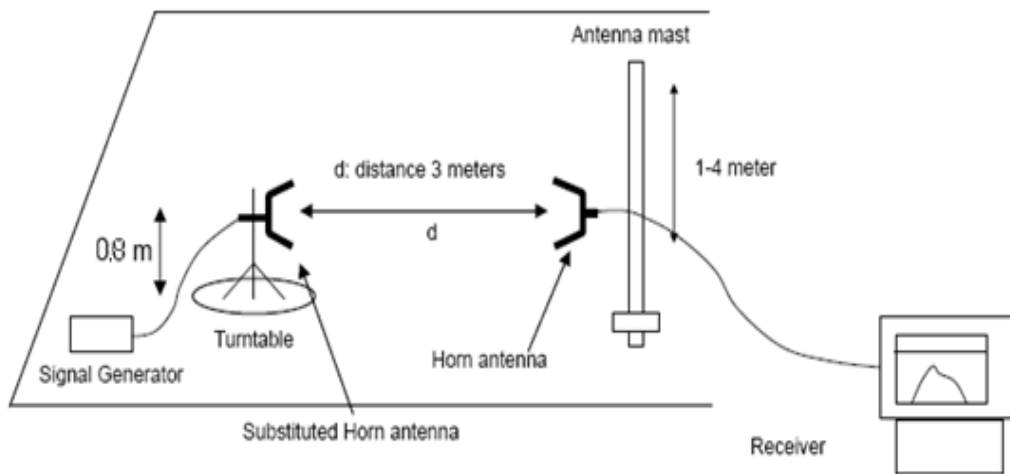
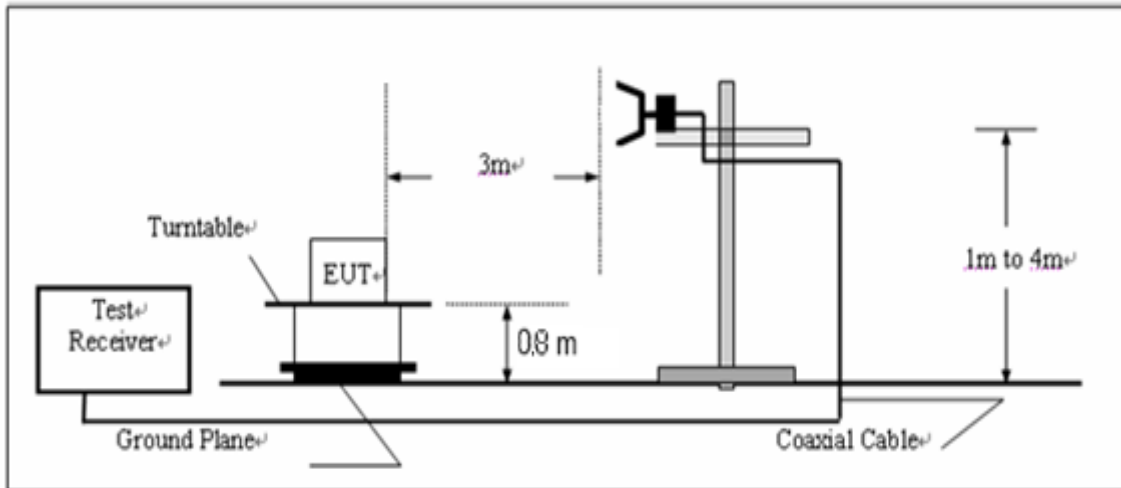

9.4 TEST RESULT

The maximum Conducted Power (CP) for VHF/UHF is
Analog: UHF/VHF for 12.5 KHz/25 KHz Channel Separation
Digital: UHF/VHF for 12.5 KHz Channel Separation
Calculation Formula: $CP = R + A + L$

* Note:

- CP: The final Conducted Power
- R : The reading value from spectrum analyzer
- A : The attenuation value of the used attenuator
- L : The loss of all connection cables

Analog:
12.5 KHz:

Conducted Power Measurement Results		
Channel Separation	Channel	Measurement Result (dBm)
		For 40.00m(10W)
12.5 KHz	Bottom(136.025MHz)	39.75
	Middle(151.850MHz)	39.81
	Middle(155.025MHz)	39.92
	Middle(161.610MHz)	39.73
	Top (173.975MHz)	39.69

Radiated Power Measurement Results		
Channel Separation	Channel	Measurement Result (dBm)
		For 40.00dBm(10W)
12.5 KHz	Bottom(136.025MHz)	39.72
	Middle(151.850MHz)	39.81
	Middle(155.025MHz)	39.83
	Middle(161.610MHz)	39.90
	Top (173.975MHz)	39.75

Conducted Power Measurement Results		
Channel Separation	Channel	Measurement Result (dBm)
		For 36.53dBm(4.5W)
12.5 KHz	Bottom(136.025MHz)	36.26
	Middle(151.850MHz)	36.35
	Middle(155.025MHz)	36.41
	Middle(161.610MHz)	36.09
	Top (173.975MHz)	36.32

Radiated Power Measurement Results		
Channel Separation	Channel	Measurement Result (dBm)
		For 36.53dBm(4.5W)
12.5 KHz	Bottom(136.025MHz)	36.16
	Middle(151.850MHz)	36.35
	Middle(155.025MHz)	36.29
	Middle(161.610MHz)	36.27
	Top (173.975MHz)	36.19

Conducted Power Measurement Results		
Channel Separation	Channel	Measurement Result (dBm)
		For 33.98dBm(2.5W)
12.5 KHz	Bottom(136.025MHz)	33.76
	Middle(151.850MHz)	33.82
	Middle(155.025MHz)	33.79
	Middle(161.610MHz)	33.74
	Top (173.975MHz)	33.83

Radiated Power Measurement Results		
Channel Separation	Channel	Measurement Result (dBm)
		For 33.98dBm(2.5W)
12.5 KHz	Bottom(136.025MHz)	33.75
	Middle(151.850MHz)	33.69
	Middle(155.025MHz)	33.67
	Middle(161.610MHz)	33.59
	Top (173.975MHz)	33.52

Conducted Power Measurement Results		
Channel Separation	Channel	Measurement Result (dBm)
		For 30dBm(1W)
12.5 KHz	Bottom(136.025MHz)	29.58
	Middle(151.850MHz)	29.74
	Middle(155.025MHz)	29.69
	Middle(161.610MHz)	29.74
	Top (173.975MHz)	29.76

Radiated Power Measurement Results		
Channel Separation	Channel	Measurement Result (dBm)
		For 30dBm(1W)
12.5 KHz	Bottom(136.025MHz)	29.75
	Middle(151.850MHz)	29.72
	Middle(155.025MHz)	29.69
	Middle(161.610MHz)	29.75
	Top (173.975MHz)	29.82

Digital:
Date + voice:

Conducted Power Measurement Results		
Channel Separation	Channel	Measurement Result (dBm)
		For 40.00dBm(10W)
12.5 KHz	Bottom(136.025MHz)	39.82
	Middle(151.850MHz)	39.75
	Middle(155.025MHz)	39.92
	Middle(161.610MHz)	39.81
	Top (173.975MHz)	39.78

Radiated Power Measurement Results		
Channel Separation	Channel	Measurement Result (dBm)
		For 40.00dBm(10W)
12.5 KHz	Bottom(136.025MHz)	39.82
	Middle(151.850MHz)	39.75
	Middle(155.025MHz)	39.91
	Middle(161.610MHz)	39.68
	Top (173.975MHz)	39.79

Conducted Power Measurement Results		
Channel Separation	Channel	Measurement Result (dBm)
		For 36.53dBm(4.5W)
12.5 KHz	Bottom(136.025MHz)	36.06
	Middle(151.850MHz)	36.25
	Middle(155.025MHz)	36.43
	Middle(161.610MHz)	36.29
	Top (173.975MHz)	36.18

Radiated Power Measurement Results		
Channel Separation	Channel	Measurement Result (dBm)
		For 36.53dBm(4.5W)
12.5 KHz	Bottom(136.025MHz)	36.08
	Middle(151.850MHz)	36.16
	Middle(155.025MHz)	36.27
	Middle(161.610MHz)	36.35
	Top (173.975MHz)	36.49

Conducted Power Measurement Results		
Channel Separation	Channel	Measurement Result (dBm)
		For 33.98dBm(2.5W)
12.5 KHz	Bottom(136.025MHz)	33.52
	Middle(151.850MHz)	33.61
	Middle(155.025MHz)	33.52
	Middle(161.610MHz)	33.63
	Top (173.975MHz)	33.69

Radiated Power Measurement Results		
Channel Separation	Channel	Measurement Result (dBm)
		For 33.98dBm(2.5W)
12.5 KHz	Bottom(136.025MHz)	33.62
	Middle(151.850MHz)	33.75
	Middle(155.025MHz)	33.82
	Middle(161.610MHz)	33.83
	Top (173.975MHz)	33.56

Conducted Power Measurement Results		
Channel Separation	Channel	Measurement Result (dBm)
		For 30dBm(1W)
12.5 KHz	Bottom(136.025MHz)	29.85
	Middle(151.850MHz)	29.72
	Middle(155.025MHz)	29.92
	Middle(161.610MHz)	29.83
	Top (173.975MHz)	29.75

Radiated Power Measurement Results		
Channel Separation	Channel	Measurement Result (dBm)
		For 30dBm(1W)
12.5 KHz	Bottom(136.025MHz)	29.53
	Middle(151.850MHz)	29.59
	Middle(155.025MHz)	29.68
	Middle(161.610MHz)	29.72
	Top (173.975MHz)	29.72

Date transmission mode:

Conducted Power Measurement Results		
Channel Separation	Channel	Measurement Result (dBm)
		For 40.00dBm(10W)
12.5 KHz	Bottom(136.025MHz)	39.83
	Middle(151.850MHz)	39.76
	Middle(155.025MHz)	39.92
	Middle(161.610MHz)	39.82
	Top (173.975MHz)	39.80

Radiated Power Measurement Results		
Channel Separation	Channel	Measurement Result (dBm)
		For 40.00dBm(10W)
12.5 KHz	Bottom(136.025MHz)	39.79
	Middle(151.850MHz)	39.88
	Middle(155.025MHz)	39.72
	Middle(161.610MHz)	39.66
	Top (173.975MHz)	39.84

Conducted Power Measurement Results		
Channel Separation	Channel	Measurement Result (dBm)
		For 36.53dBm(4.5W)
12.5 KHz	Bottom(136.025MHz)	36.22
	Middle(151.850MHz)	36.15
	Middle(155.025MHz)	36.34
	Middle(161.610MHz)	36.23
	Top (173.975MHz)	36.38

Radiated Power Measurement Results		
Channel Separation	Channel	Measurement Result (dBm)
		For 36.53dBm(4.5W)
12.5 KHz	Bottom(136.025MHz)	36.13
	Middle(151.850MHz)	36.16
	Middle(155.025MHz)	36.08
	Middle(161.610MHz)	36.46
	Top (173.975MHz)	36.35

Conducted Power Measurement Results		
Channel Separation	Channel	Measurement Result (dBm)
		For 33.98dBm(2.5W)
12.5 KHz	Bottom(136.025MHz)	33.82
	Middle(151.850MHz)	33.61
	Middle(155.025MHz)	33.75
	Middle(161.610MHz)	33.69
	Top (173.975MHz)	33.75

Radiated Power Measurement Results		
Channel Separation	Channel	Measurement Result (dBm)
		For 33.98dBm(2.5W)
12.5 KHz	Bottom(136.025MHz)	33.72
	Middle(151.850MHz)	33.49
	Middle(155.025MHz)	33.58
	Middle(161.610MHz)	33.61
	Top (173.975MHz)	33.73

Conducted Power Measurement Results		
Channel Separation	Channel	Measurement Result (dBm)
		For 30dBm(1W)
12.5 KHz	Bottom(136.025MHz)	29.82
	Middle(151.850MHz)	29.46
	Middle(155.025MHz)	29.57
	Middle(161.610MHz)	29.78
	Top (173.975MHz)	29.76

Radiated Power Measurement Results		
Channel Separation	Channel	Measurement Result (dBm)
		For 30dBm(1W)
12.5 KHz	Bottom(136.025MHz)	29.74
	Middle(151.850MHz)	29.68
	Middle(155.025MHz)	29.63
	Middle(161.610MHz)	29.53
	Top (173.975MHz)	29.76

9.5 CONDUCT SPURIOUS PLOT

Analog:
12.5 KHz:

Conducted Spurious Emission (worst) @151.850 MHz With 12.5 KHz Channel Separation-10W
30MHz-1GHz

