FCC Test Report

Report No.: AGC00589140202F1

FCC ID : T4K588V2
TYPE OF AUTHORIZATION : Certification
APPLICATION PURPOSE : Original Equipment
PRODUCT DESIGNATION : Land Mobile Radio
BRAND NAME : N/A
TEST MODEL : 588
CLIENT : Qixiang Electron Science & Technology Co., Ltd. Quanzhou
DATE OF ISSUE : Feb.18, 2014
STANDARD(S) : FCC Part 15 Rules
REPORT VERSION : V 1.0

Attestation of Global Compliance (Shenzhen) Co., Ltd

CAUTION:

This report shall not be reproduced except in full without the written permission of the test laboratory and shall not be quoted out of context.

Report Revise Record

Report Version	Revise Time	Issued Date	Valid Version	Notes
V1.0	/	Feb.18, 2014	Valid	Original Report

TABLE OF CONTENTS

1. VERIFICATION OF COMPLIANCE	4
2. PRODUCT INFORMATION	5
3. TEST FACILITY	6
4. SUPPORT EQUIPMENT LIST	7
5. SYSTEM DESCRIPTION	7
6 SUMMARY OF TEST RESULTS	8
7. FCC LINE CONDUCTED EMISSION TEST	9
7.1. TEST EQUIPMENT OF LINE CONDUCTED EMISSION TEST	9
7.2 .LIMITS OF LINE CONDUCTED EMISSION TEST	9
7.3. BLOCK DIAGRAM OF LINE CONDUCTED EMISSION TEST	9
7.4. PROCEDURE OF LINE CONDUCTED EMISSION TEST	10
7.5 TEST RESULT OF LINE CONDUCTED EMISSION TEST	11
8. FCC RADIATED EMISSION TEST	12
8.1. TEST EQUIPMENT OF RADIATED EMISSION	12
8.2. LIMITS OF RADIATED EMISSION TEST	12
8.3 BLOCK DIAGRAM OF RADIATED EMISSION TEST	12
8.4 PROCEDURE OF RADIATED EMISSION TEST	13
8.5 TEST RESULT OF RADIATED EMISSION TEST	14
APPENDIX 1	18
PHOTOGRAPHS OF TEST SETUP	18
APPENDIX 2	19
PHOTOGRAPHS OF EUT	19

1. VERIFICATION OF COMPLIANCE

Applicant	Qixiang Electron Science & Technology Co., Ltd. Quanzhou
Address	Qixiang Building, Tangxi Industrial Zone, Luojiang District, Quanzhou, Fujian, China
Manufacturer	Qixiang Electron Science & Technology Co., Ltd. Quanzhou
Address	Qixiang Building, Tangxi Industrial Zone, Luojiang District, Quanzhou, Fujian, China
Product Designation	Land Mobile Radio
Brand name:	N/A
Test Model	588
Hardware Version:	N/A
Software Version:	N/A
Measurement Procedure	ANSI C63.4: 2003
Date of test:	Feb.13, 2014 to Feb.17, 2014
Deviation:	None
Condition of Test Sample	Normal

The above equipment was tested by Attestation Of Global Compliance (Shenzhen) Co., Ltd. for compliance with the requirements set forth in the FCC Rules and Regulations Part 15, the measurement procedure according to ANSI C63.4:2003. This said equipment in the configuration described in this report shows the maximum emission levels emanating from equipment are within the compliance requirements.

The test results of this report relate only to the tested sample identified in this report.

Test By: Wall Huang
Wall Huang Feb.18, 2014

Reviewed By: Kidd Yang
Kidd Yang Feb.18, 2014

Authorized By: Solger Zhang
Solger Zhang Feb.18, 2014

2. PRODUCT INFORMATION

The EUT is a VHF FM MOBILE TRANSCEIVER designed for voice communication. It is designed by way of utilizing the FM modulation achieves the system operating.
A major technical description of EUT is described as following:

Communication Type	Voice / Tone only
Modulation	FM
Emission Type	11K ϕ F3E
RX Frequency Range	220-260MHz
Antenna Designation	Detachable
Power Supply	DC 13.8V by DC source

I/O Port Information (Applicable Not Applicable)

I/O Port of EUT			
I/O Port Type	Q'TY	Cable	Tested with
DC Input Port	1	1.5m, Unshielded	1
Antenna Connect Port	1	0	1
Hand-Operated Microphone Connect Port	1	0.5m, Unshielded	1
Cigar-Plug connect Port	1	0	1
External Speaker connect Port	1	0	1

3. TEST FACILITY

Facility Attestation of Global Compliance (Shenzhen) Co., Ltd

Location: 2/F., Building 2, No.1-No.4, Chaxi Sanwei Technical Industrial Park, Gushu,
Xixiang, Bao'an District, Shenzhen, Guangdong, China

Description: The test site is constructed and calibrated to meet the FCC requirements in
documents ANSI C63.4:2003.

Site Filing: The FCC Registration Number is 259865

Instrument Tolerance: All measuring equipment is in accord with ANSI C63.4 requirements that meet
industry regulatory agency and accreditation agency requirement.

4. SUPPORT EQUIPMENT LIST

Device Type	Manufacturer	Model Name	Serial No.	Data Cable	Power Cable
--	--	--	--	--	--

5. SYSTEM DESCRIPTION

EUT test procedure:

1. Connect EUT and peripheral devices.
2. Power on the EUT, the EUT begins to work.
3. Running data transmission and make sure the EUT normal working.

EMC TEST MODES

No.	TEST MODES
1	Scanning mode + Receiving mode

Note: Only the result of the worst case was recorded in the report.

6. SUMMARY OF TEST RESULTS

FCC Rules	Description Of Test	Result
§15.107	Conduction Emission	N/A
§15.109	Radiated Emission	Compliant
§15.121	Scanning receivers and frequency converters used with scanning receivers.	Compliant

7. FCC LINE CONDUCTED EMISSION TEST

7.1. TEST EQUIPMENT OF LINE CONDUCTED EMISSION TEST

Description	Manufacturer	Model	Identifier	Cal. Date	Cal. Due
Spectrum Analyzer	Agilent	E4440A	US41421290	07/18/2013	07/17/2014
EMI Test Receiver	Rohde & Schwarz	ESCI	100694	07/18/2013	07/17/2014
LISN	Rohde & Schwarz	ESH2-Z5	862060/020	07/18/2013	07/17/2014

7.2 .LIMITS OF LINE CONDUCTED EMISSION TEST

Frequency	Maximum RF Line Voltage	
	Q.P.(dBuV)	Average(dBuV)
150kHz~500kHz	66-56	56-46
500kHz~5MHz	56	46
5MHz~30MHz	60	50

**Note: 1. The lower limit shall apply at the transition frequency.

2. The limit decreases linearly with the logarithm of the frequency in the range 0.15 MHz to 0.50 MHz

7.3. BLOCK DIAGRAM OF LINE CONDUCTED EMISSION TEST

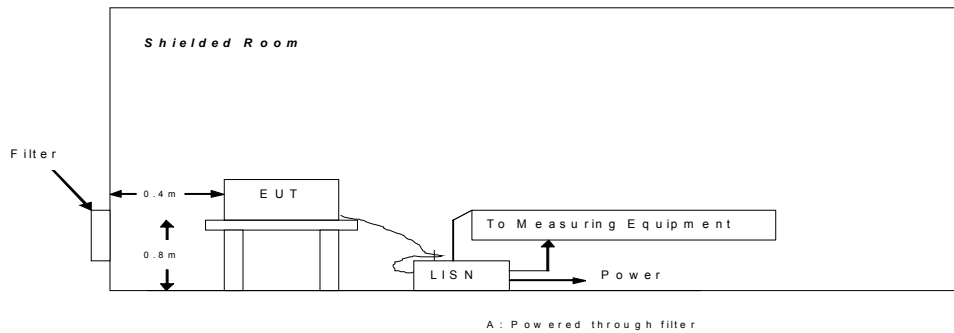

7.4. PROCEDURE OF LINE CONDUCTED EMISSION TEST

- 1) The equipment was set up as per the test configuration to simulate typical actual usage per the user's manual. When the EUT is a tabletop system, a wooden table with a height of 0.8 meters is used and is placed on the ground plane as per ANSI C63.4 (see Test Facility for the dimensions of the ground plane used). When the EUT is a floor-standing equipment, it is placed on the ground plane which has a 3-12 mm non-conductive covering to insulate the EUT from the ground plane.
- 2) Support equipment, if needed, was placed as per ANSI C63.4.
- 3) All I/O cables were positioned to simulate typical actual usage as per ANSI C63.4.
The EUT received power through a Line Impedance Stabilization Network (LISN) that was grounded to the protect earth.
- 4) The EUT test program was started. Emissions were measured on each current carrying line of the EUT using a spectrum Analyzer / Receiver connected to the LISN powering the EUT. The LISN has two monitoring points: Line 1 (Hot Side) and Line 2 (Neutral Side). Two scans were taken: one with Line 1 connected to Analyzer / Receiver and Line 2 connected to a 50 ohm load; the second scan had Line 1 connected to a 50 ohm load and Line 2 connected to the Analyzer / Receiver.
- 5) Analyzer / Receiver scanned from 150 kHz to 30MHz for emissions in each of the test modes.
- 6) During the above scans, the emissions were maximized by cable manipulation.
- 7) A scan was taken on both power lines, Line 1 and Line 2, recording at least the six highest emissions.
- 8) Emission frequency and amplitude were recorded into a computer in which correction factors were used to calculate the emission level and compare reading to the applicable limit. If EUT emission level was less -2dB to the A.V. limit in Peak mode, then the emission signal was re-checked using Q.P and Average detector.

The test data of the worst case condition (mode 2) was reported on the following Data page.

7.5 TEST RESULT OF LINE CONDUCTED EMISSION TEST
N/A

8. FCC RADIATED EMISSION TEST

8.1. TEST EQUIPMENT OF RADIATED EMISSION

Description	Manufacturer	Model	Identifier	Cal. Date	Cal. Due
PSA SERIES SPECTRUM ANALYZER	AGILENT	E4440A	US41421290	07/18/2013	07/17/2014
ANTENNA	A.H.	SAS-521-4	26	07/18/2013	07/17/2014
HORN ANTENNA	EM	EM-AH-10180	67	04/21/2013	04/20/2014
AMPLIFIER	EM	EM30180	0607030	07/18/2013	07/17/2014
POSITIONING CONTROLLER	MF	MF-7802	MF780208147	07/18/2013	07/17/2014

8.2. LIMITS OF RADIATED EMISSION TEST

Frequency (MHz)	Distance (m)	Maximum Field Strength Limit (dBuV/m/ Q.P.)
30~88	3	40.0
88~216	3	43.5
216~960	3	46.0
Above 960	3	54.0

**Note: The lower limit shall apply at the transition frequency.

8.3 BLOCK DIAGRAM OF RADIATED EMISSION TEST

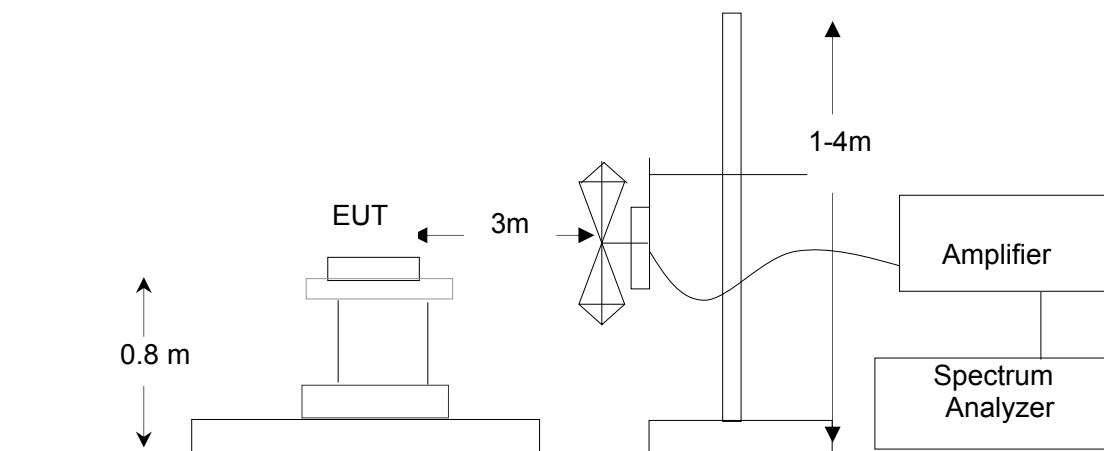

8.4 PROCEDURE OF RADIATED EMISSION TEST

- 1) The equipment was set up as per the test configuration to simulate typical actual usage per the user's manual. When the EUT is a tabletop system, a wooden turntable with a height of 0.8 meters is used which is placed on the ground plane as per ANSI C63.4 (see Test Facility for the dimensions of the ground plane used). When the EUT is floor-standing equipment, it is placed on the ground plane which has a 3-12 mm non-conductive covering to insulate the EUT from the ground plane.
- 2) Support equipment, if needed, was placed as per ANSI C63.4.
- 3) All I/O cables were positioned to simulate typical actual usage as per ANSI C63.4.
- 4) The EUT received DC 13.8V by DC source. All support equipments received AC 120V/60Hz power from socket under the turntable, if any.
- 5) The antenna was placed at 3 meter away from the EUT as stated in FCC Part 15. The antenna connected to the Analyzer via a cable and at times a pre-amplifier would be used.
- 6) The Analyzer / Receiver quickly scanned from 30MHz to 1000MHz. The EUT test program was started. Emissions were scanned and measured rotating the EUT to 360 degrees and positioning the antenna 1 to 4 meters above the ground plane, in both the vertical and the horizontal polarization, to maximize the emission reading level.
- 7) The test mode(s) were scanned during the test:
- 8) Recorded at least the six highest emissions. Emission frequency, amplitude, antenna position, polarization and turntable position were recorded into a computer in which correction factors were used to calculate the emission level and compare reading to the applicable limit and Q.P./Peak reading is presented.

The test data of the worst case condition(mode 1) was reported on the following Data page

8.5 TEST RESULT OF RADIATED EMISSION TEST

Radiated Emission Test –Horizontal -3m Below 1G

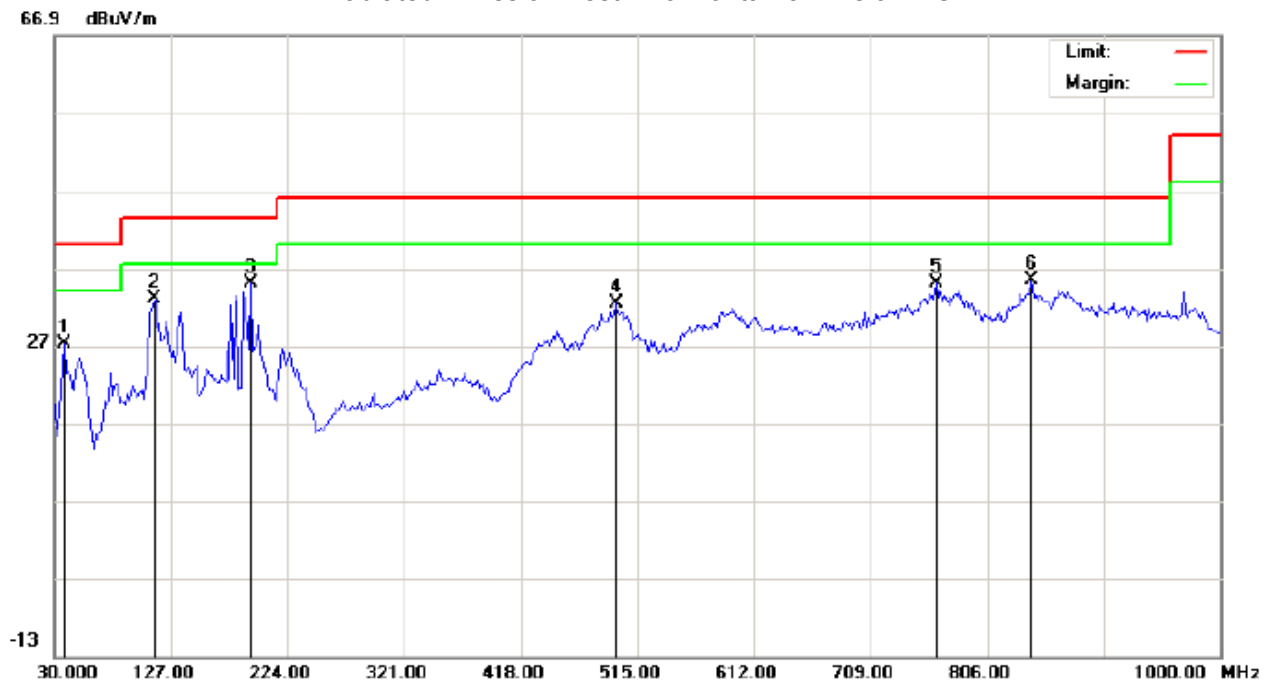

Site: site #1
Limit: FCC Class B 3M Radiation
EUT: Land Mobile Radio
M/N: 588
Mode: Mode 1
Note:

Polarization: *Horizontal*
Power:
Distance:

Temperature: 26
Humidity: 60 %

No.	Mk	Freq.	Reading	Factor	Measurement	Limit	Over	Detector	Antenna Height	Table Degree	Comment
		MHz	dBuV	dB/m	dBuV/m	dBuV/m	dB		cm	degree	
1		38.0833	17.78	9.37	27.15	40.00	-12.85	peak			
2		114.0665	20.78	12.23	33.01	43.50	-10.49	peak			
3	*	193.2831	27.27	7.67	34.94	43.50	-8.56	peak			
4		497.2167	9.58	22.78	32.36	46.00	-13.64	peak			
5		763.9664	7.25	27.66	34.91	46.00	-11.09	peak			
6		843.1833	4.40	30.99	35.39	46.00	-10.61	peak			

Radiated Emission Test –Vertical -3m Below 1G



Site: site #1
Limit: FCC Class B 3M Radiation
EUT: Land Mobile Radio
M/N: 588
Mode: Mode 1
Note:

Polarization: *Vertical*
Power:
Distance:

Temperature: 26
Humidity: 60 %

No.	Mk	Freq.	Reading	Factor	Measurement	Limit	Over	Detector	Antenna Height	Table Degree	Comment
		MHz	dBuV	dB/m	dBuV/m	dBuV/m	dB		cm	degree	
1		39.7000	21.67	7.76	29.43	40.00	-10.57	peak			
2		89.8167	21.90	8.37	30.27	43.50	-13.23	peak			
3		122.1500	24.93	6.11	31.04	43.50	-12.46	peak			
4	*	181.9667	26.48	7.80	34.28	43.50	-9.22	peak			
5		193.2833	22.46	9.34	31.80	43.50	-11.70	peak			
6		692.8333	8.21	26.34	34.55	46.00	-11.45	peak			

Radiated Emission Test –Horizontal -3m Above 1G

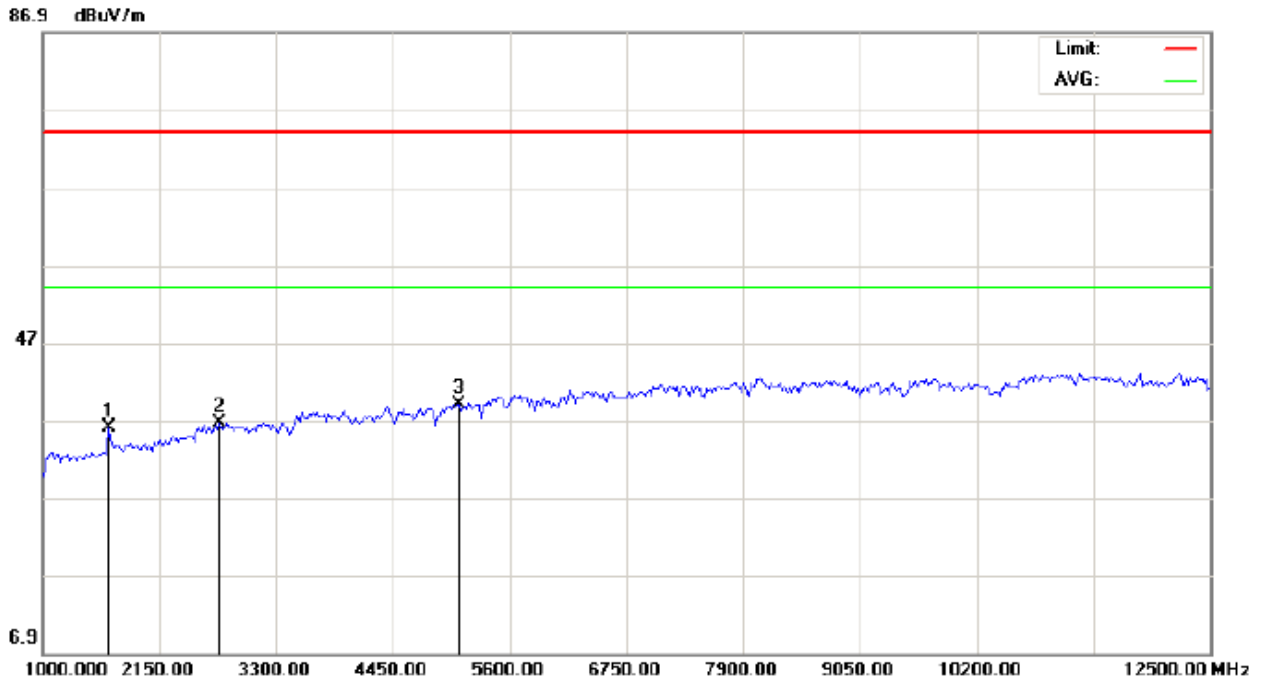

Site: site #1 Polarization: *Horizontal* Temperature: 26
Limit: FCC Class B 3M Radiation above 1GHZ(PK) Power: Humidity: 60 %
EUT: Land Mobile Radio Distance:
M/N: 588
Mode: Mode 1
Note:

No.	Mk	Freq.	Reading	Factor	Measurement	Limit	Over	Detector	Antenna Height	Table Degree	Comment
		MHz	dBuV	dB/m	dBuV/m	dBuV/m	dB		cm	degree	
1		1651.667	2.36	33.68	36.04	74.00	-37.96	peak			
2		2744.167	-2.53	39.06	36.53	74.00	-37.47	peak			
3	*	5101.667	39.07	0.00	39.07	74.00	-34.93	peak			

Radiated Emission Test –Vertical -3m Above 1G

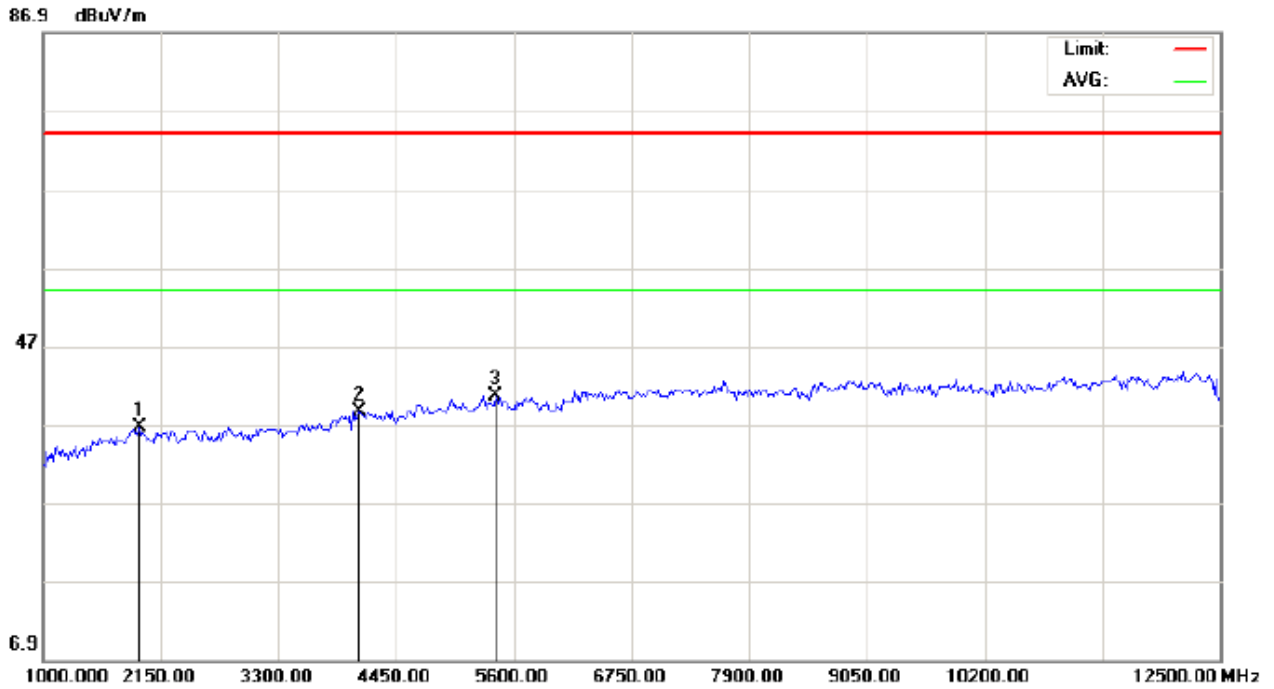

Site: site #1
Limit: FCC Class B 3M Radiation above 1GHZ(PK)
EUT: Land Mobile Radio
M/N: 588
Mode: Mode 1
Note:

Polarization: *Vertical*
Power:
Distance:

Temperature: 26
Humidity: 60 %

No.	Mk	Freq.	Reading	Factor	Measurement	Limit	Over	Detector	Antenna Height	Table Degree	Comment
		MHz	dBuV	dB/m	dBuV/m	dBuV/m	dB		cm	degree	
1		1939.167	1.93	34.74	36.67	74.00	-37.33	peak			
2		4085.833	38.65	0.00	38.65	74.00	-35.35	peak			
3	*	5427.500	40.57	0.00	40.57	74.00	-33.43	peak			

APPENDIX 1
PHOTOGRAPHS OF TEST SETUP
RADIATED TEST SETUP

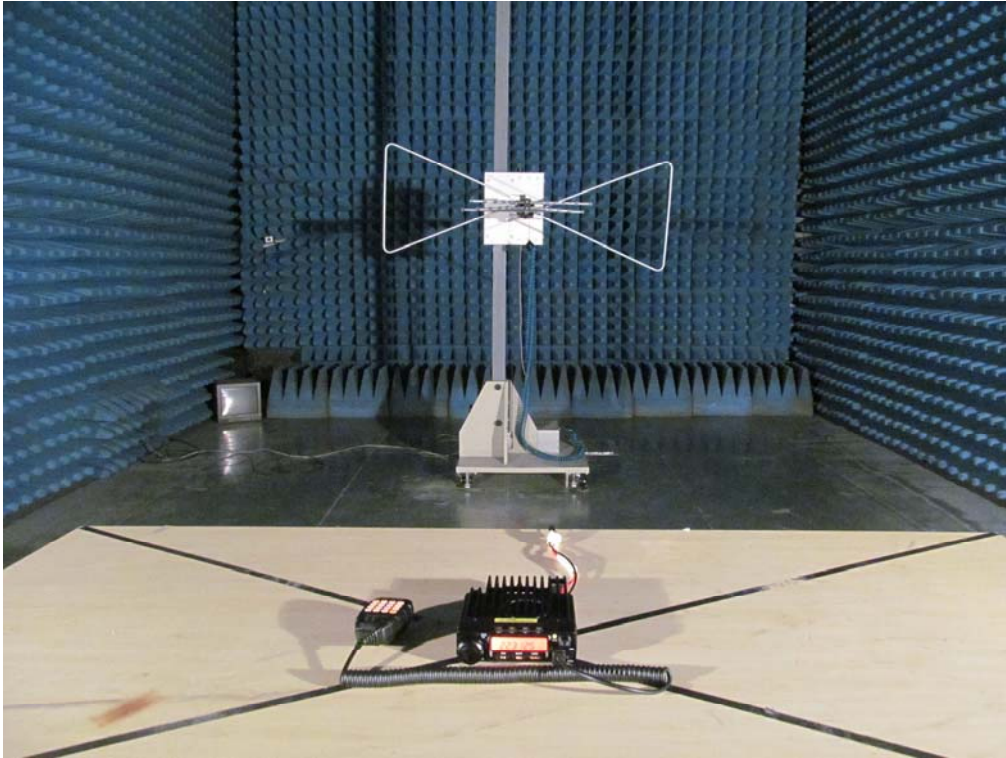

APPENDIX 2
PHOTOGRAPHS OF EUT
WHOLE VIEW OF EUT



TOP VIEW OF EUT



BOTTOM VIEW OF EUT



FRONT VIEW OF EUT



BACK VIEW OF EUT



LEFT VIEW OF EUT

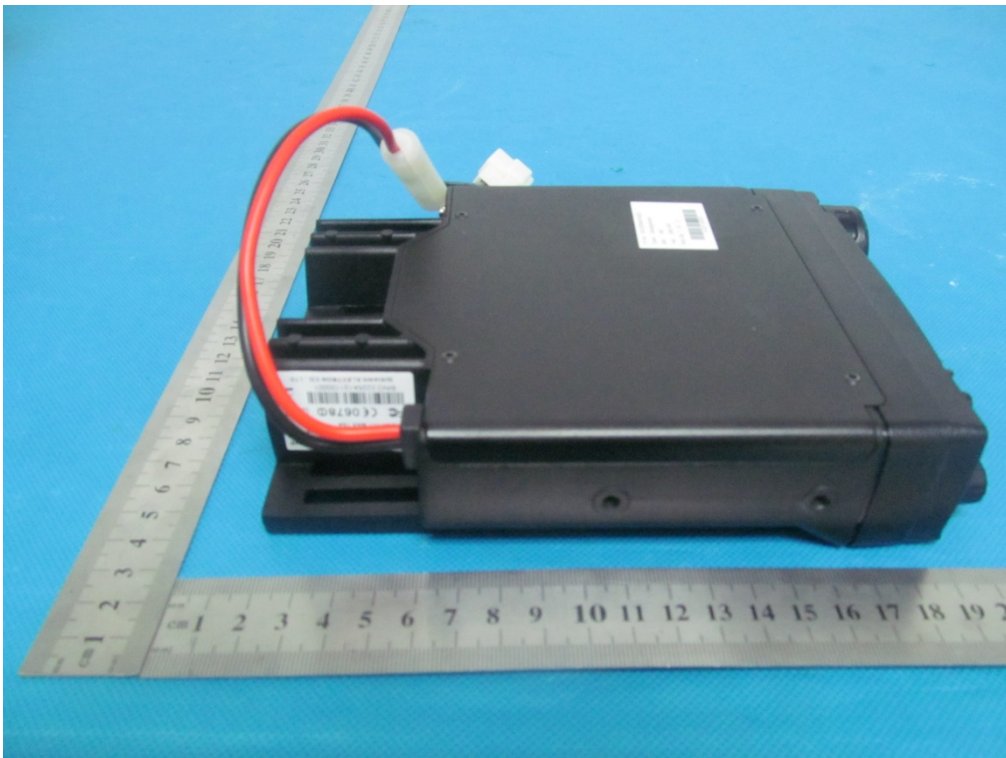

RIGHT VIEW OF EUT



OPEN VIEW-1 OF EUT

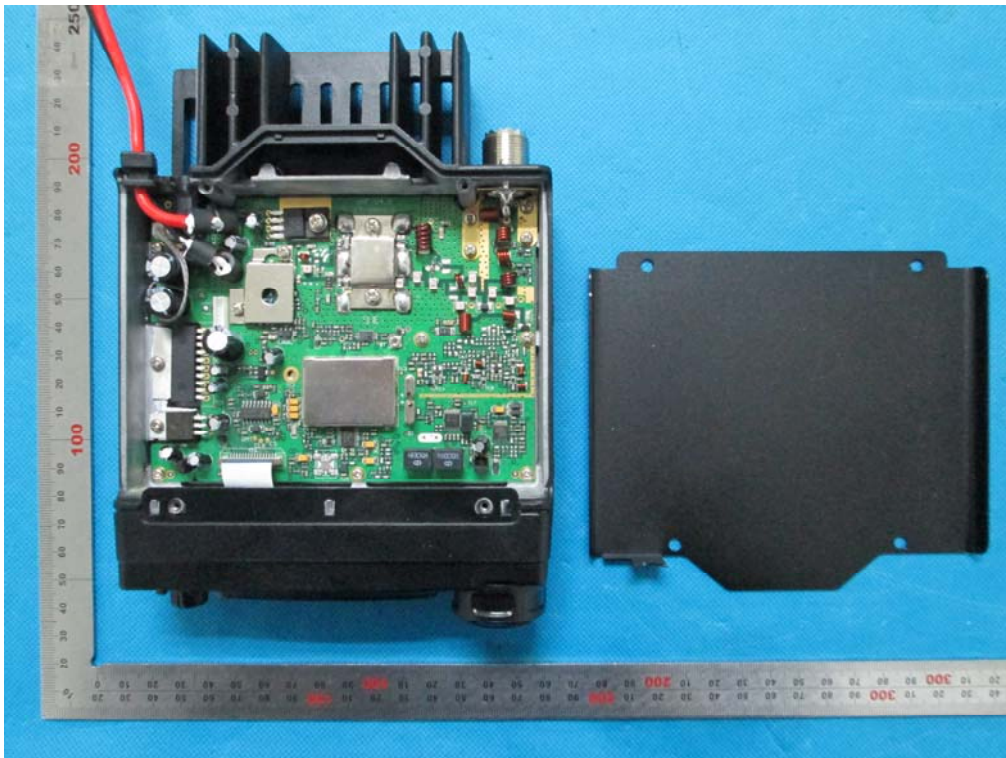

OPEN VIEW-2 OF EUT

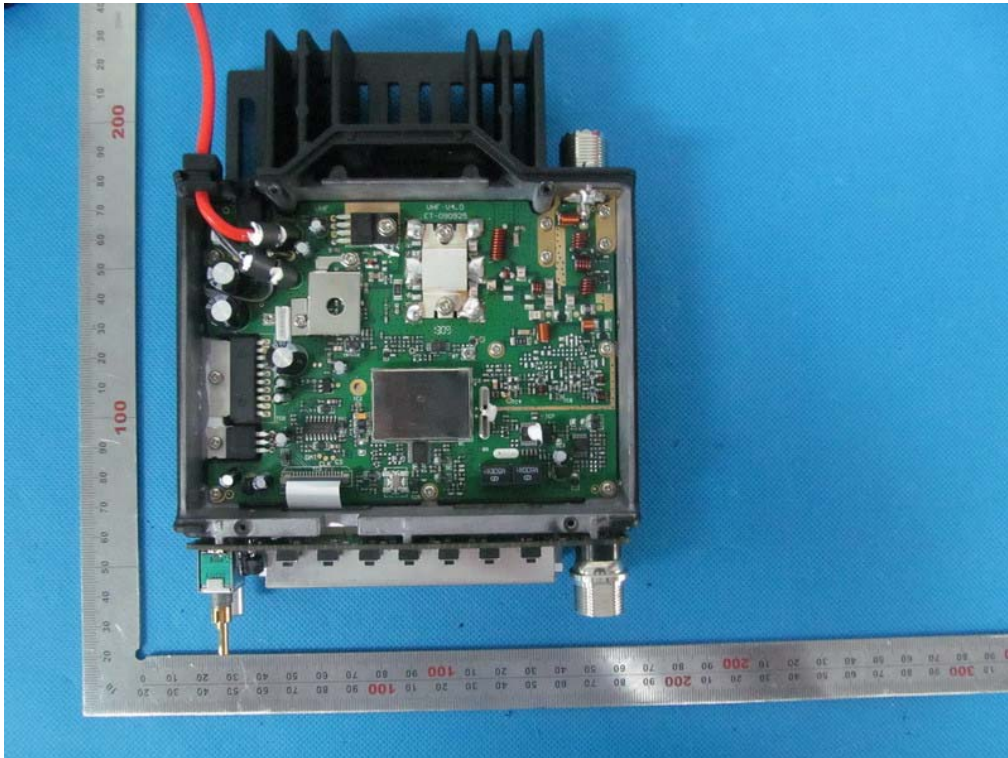

INTERNAL VIEW-1 OF EUT

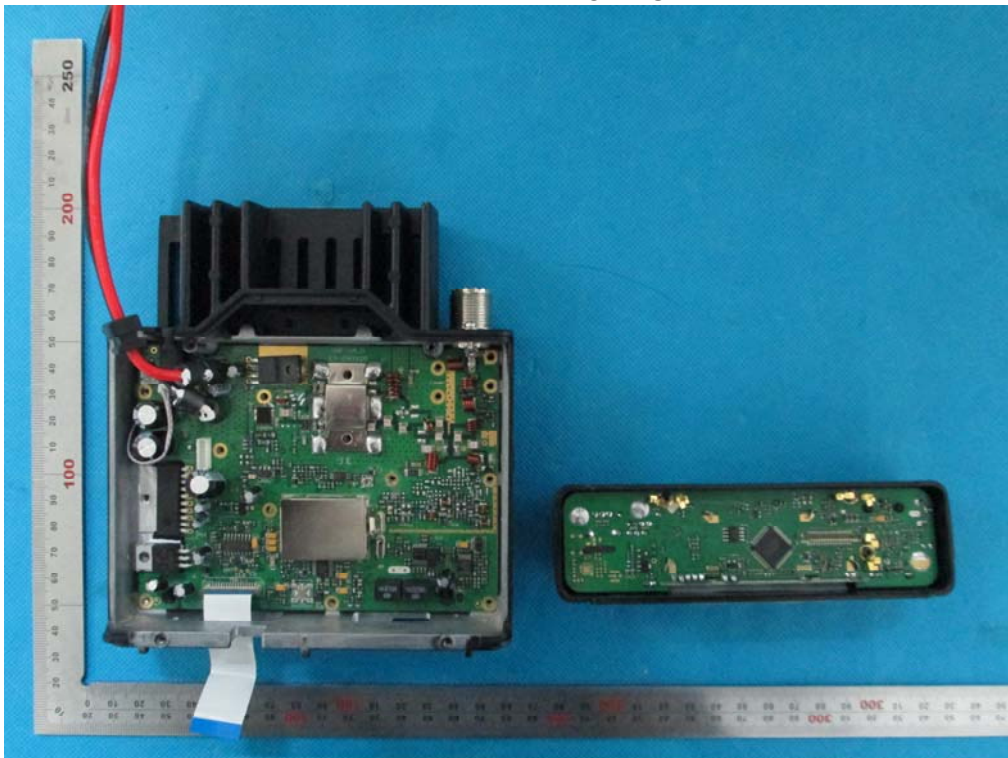

INTERNAL VIEW-2 OF EUT

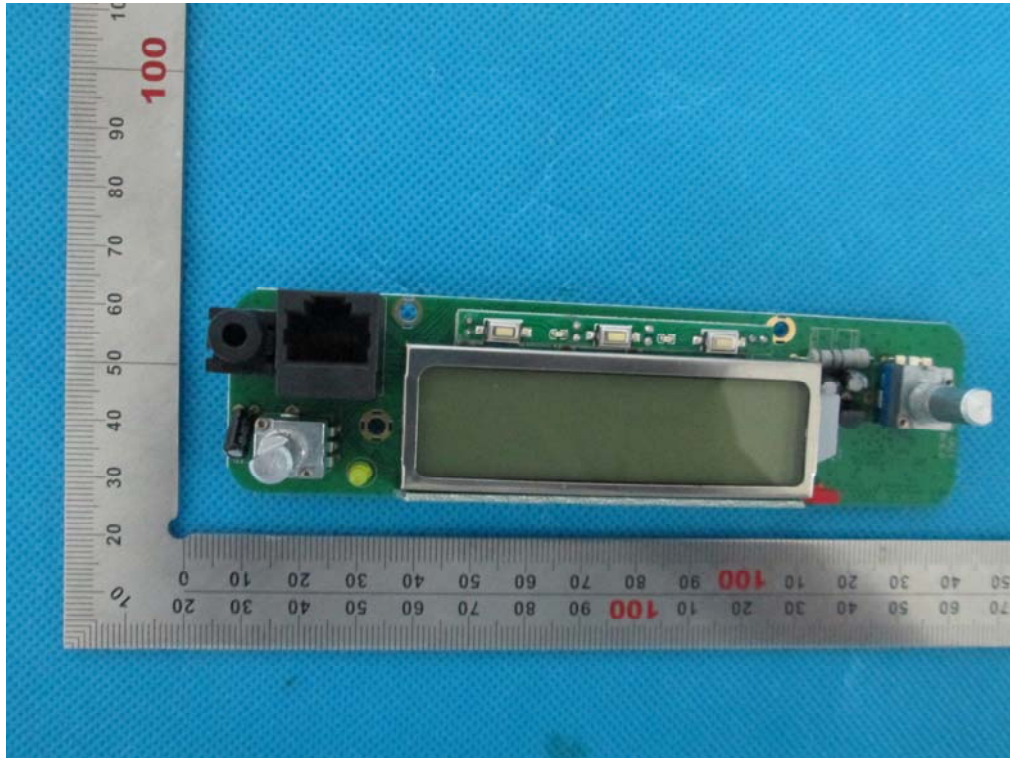

INTERNAL VIEW-3 OF EUT

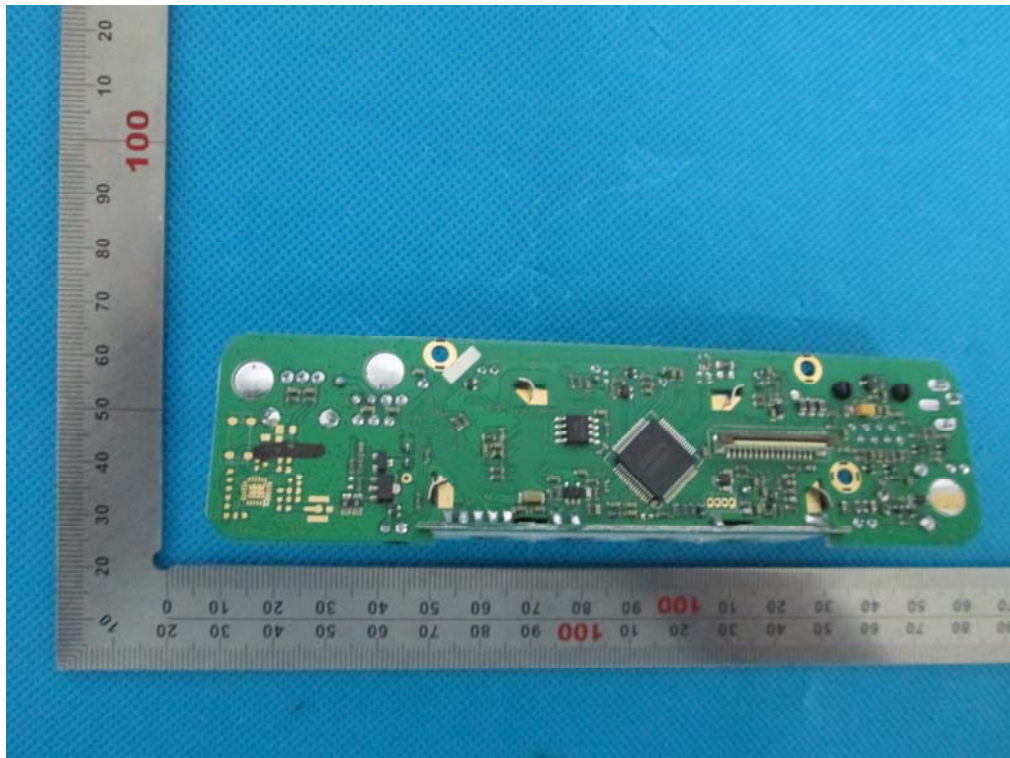

INTERNAL VIEW-4 OF EUT

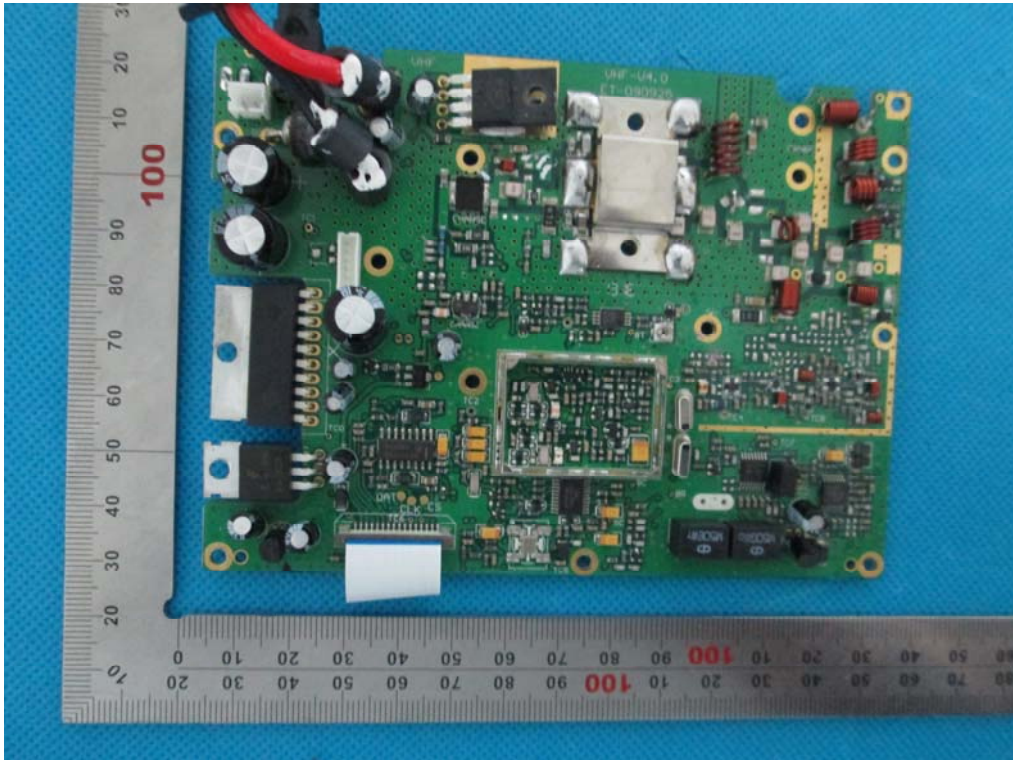

INTERNAL VIEW-5 OF EUT

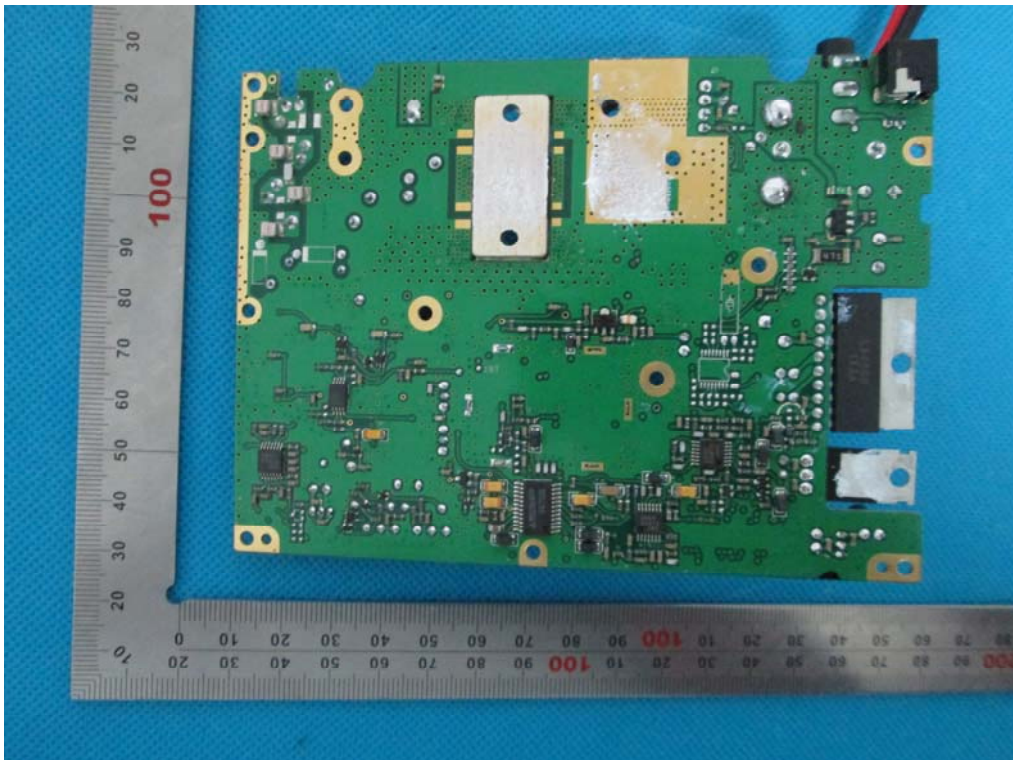

INTERNAL VIEW-6 OF EUT

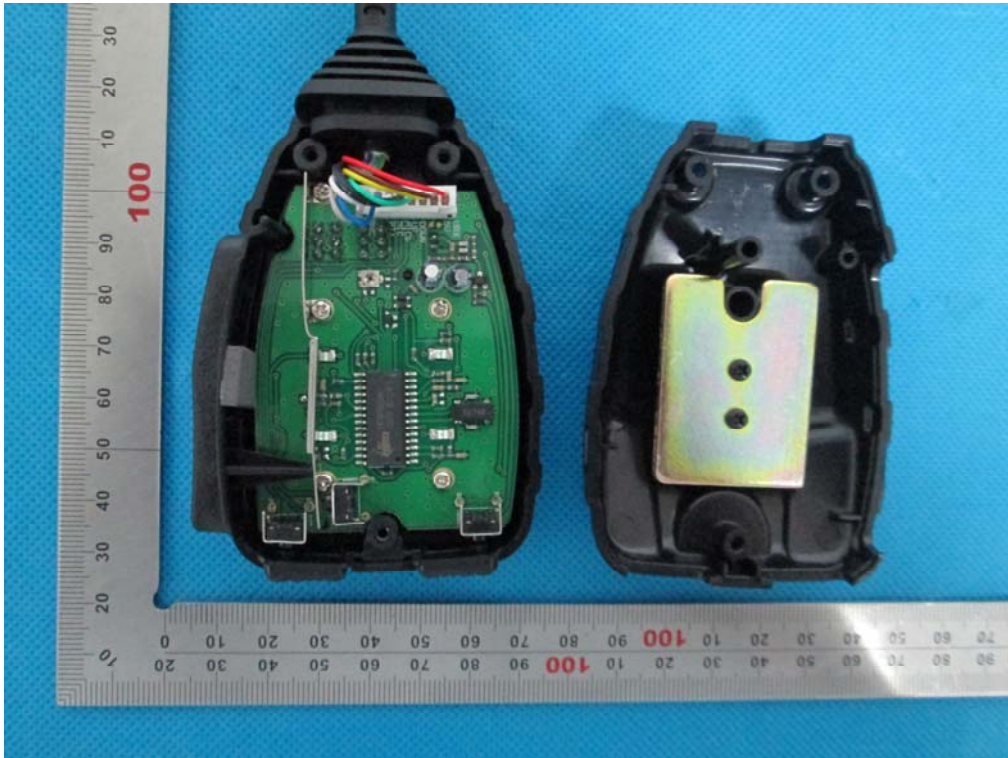

INTERNAL VIEW-7 OF EUT

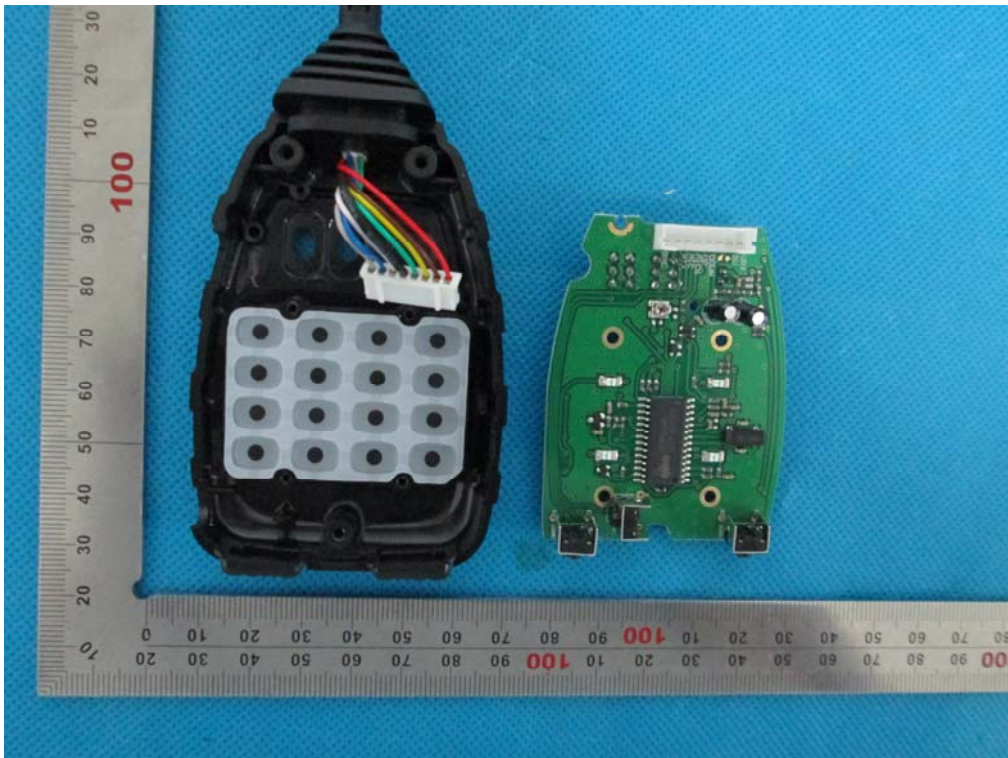

INTERNAL VIEW-8 OF EUT

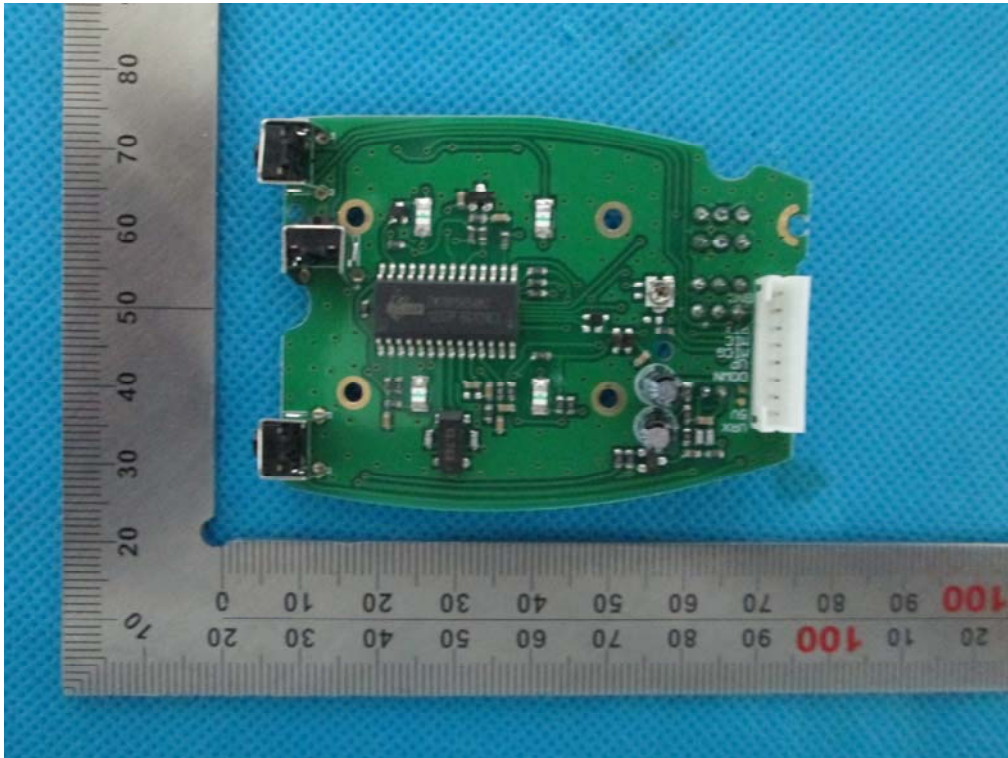

INTERNAL VIEW-9 OF EUT

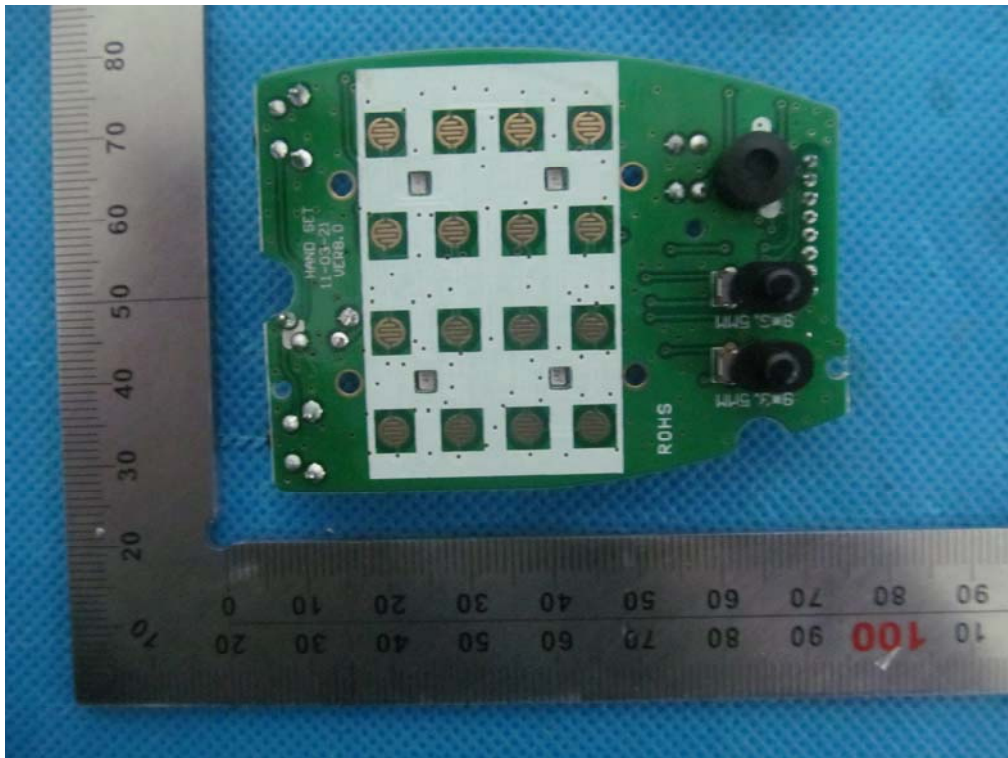

----END OF REPORT----