



**TUV Rheinland
of North America**

Emissions Test Report

EUT Name: WI-JACK DUO

EUT Model: OR-AP-DUOWJ

FCC Title 47, Part 15, SubpartC, RSS-210 Issue 6

Prepared for:

Kourosch Parsa, Ph.D.
Ortronics
125 Eugene O'Neill Drive
New London, CT 06320
Tel: 860-405-2952
Fax: 860-405-2990

Prepared by:

TUV Rheinland of North America
762 Park Avenue
Youngsville, NC 27596
Tel: (919) 554-0901
Fax: (919) 556-2043
<http://www.tuv.com/>

Report/Issue Date: 29 June 2006
Report Number: 30660840.003

Statement of Compliance

Manufacturer: Ortronics
125 Eugene O'Neill Drive
New London, CT 06320
860-405-2952
Requester / Applicant: Kourosh Parsa, Ph.D.
Name of Equipment: WI-JACK DUO
Model No. OR-AP-DUOWJ
Type of Equipment: Intentional Radiator
Application of Regulations: FCC Title 47, Part 15, SubpartC, RSS-210 Issue 6
Test Dates: 05 May 2006 to 11 May 2006

Guidance Documents:

Emissions: FCC 47 CFR Part 15.407, RSS-210 Issue 6

Test Methods:

Emissions: ANSI C63.4:2003

The electromagnetic compatibility test and documented data described in this report has been performed and recorded by TUV Rheinland of North America, in accordance with the standards and procedures listed herein. As the responsible authorized agent of the EMC laboratory, I hereby declare that a sample of one, of the equipment described above, has been shown to be compliant with the EMC requirements of the stated regulations and standards based on these results. If any special accessories and/or modifications were required for compliance, they are listed in the Executive Summary of this report.

This report must not be used to claim product endorsement by NVLAP or any agency of the U.S. Government. This report contains data that are not covered by NVLAP accreditation. This report shall not be reproduced except in full, without the written authorization of the laboratory.

29 June 2006

29 June 2006

Test Engineer

Date

NVLAP Signatory

Date



200094-0



90552 and
100881

Industry Canada

IC3755

1	EXECUTIVE SUMMARY	4
1.1	SCOPE.....	4
1.2	PURPOSE.....	4
1.3	SUMMARY OF TEST RESULTS.....	4
1.4	SPECIAL ACCESSORIES OR EQUIPMENT MODIFICATIONS	4
2	LABORATORY INFORMATION	5
2.1	ACCREDITATIONS & ENDORSEMENTS	5
2.2	TEST FACILITIES.....	6
2.3	MEASUREMENT UNCERTAINTY.....	6
2.4	CALIBRATION TRACEABILITY	6
3	PRODUCT INFORMATION	7
3.1	PRODUCT DESCRIPTION	7
3.2	EQUIPMENT CONFIGURATION	8
3.3	OPERATION MODE	8
4	EMISSIONS	9
4.1	26DB AND 99% BANDWIDTH; §15.407(A), RSS-210 §6.2.2(Q1)(I-III)	9
4.2	OUTPUT POWER; FCC §15.407(A), RSS-210 §6.2.2(Q1)	14
4.3	FREQUENCY STABILITY FCC PART 15.407(G), RSS-210 PART 6.2.2.(Q1)(IV)(G)	21
4.4	MAXIMUM PERMISSIBLE EXPOSURE; FCC §15.407(F), RSS-210 §6.2.2(Q1)(IV)(G)	22
4.5	BAND-EDGE MEASUREMENT FCC §15.407(B), RSS-210 §6.2.2(O)(E1).....	24
4.6	PEAK EXCURSION RATIO; FCC §15.407(A)(6).....	30
4.7	CONDUCTED SPURIOUS EMISSIONS; FCC §15.407(B), RSS-210 §6.2.2(O)(E1)	34
4.8	PEAK POWER SPECTRAL DENSITY; FCC §15.407(E), RSS-210 §6.2.2(O)(B).....	39
4.9	SPURIOUS EMISSIONS; FCC §§15.205, 15.209, 15.407(B), RSS-210 §6.2.2(Q1)	42
4.10	AC CONDUCTED EMISSIONS; FCC §15.207(B), RSS-210 §§6.6(B),7.4	54
5	TEST EQUIPMENT USE LIST	57
6	EMC TEST PLAN	58
6.1	INTRODUCTION.....	58
6.2	CUSTOMER	58
6.3	EQUIPMENT UNDER TEST (EUT)	59
6.4	EQUIVALENT MODELS	64
6.5	TEST SPECIFICATIONS	65

1 Executive Summary

1.1 Scope

This report is intended to document the status of conformance with the requirements of the FCC Title 47, Part 15, SubpartC, RSS-210 Issue 6 based on the results of testing performed on 05 May 2006 through 11 May 2006 on the *WI-JACK DUO* Model No. *OR-AP-DUOWJ* manufactured by Ortronics. This report only applies to the specific samples tested under the stated test conditions. It is the responsibility of the manufacturer to assure that additional production units of this model are manufactured with identical or EMI equivalent electrical and mechanical components. This report is further intended to document changes and modifications to the EUT throughout its life cycle. All documentation will be included as a supplement.

1.2 Purpose

Testing was performed to evaluate the EMC performance of the EUT in accordance with the applicable requirements, procedures, and criteria defined in the application of regulations and application of standards listed in this report.

1.3 Summary of Test Results

Table 1 - Summary of Test Results

Test	Test Method(s) FCC	Test Method(s) Industry Canada	Test Parameters	Result
Occupied Bandwidth	FCC Part 15.407(a)	RSS-210 part 6.2.2(q1)	-26dB and 99%	compliant
Peak Transmit Power	FCC Part 15.407(a)(1-2)	RSS-210 part 6.2.2(q1)	50mW, 250mW	compliant
Peak Power Spectral Density	FCC Part 15.407(a)	RSS-210 part 6.2.2(q1)	≤ 8dBm at 10kHz BW	compliant
Frequency Stability	FCC Part 15.407(g)	RSS-210 part 6.2.2(q1)		
Maximum Permissible Exposure	FCC Part 15.407(f)	RSS-210 part 6.2.2(q1)(iv)(g)	1MW/CM ²	compliant
Peak Excursion Ratio	FCC Part 15.407(a)(6)		<13dB in any 1 MHz bandwidth	compliant
Conducted Spurious Emissions	FCC Part 15.407(b)(1)	RSS-210 part 6.2.2(q1)(ii)	-20dB of P _{max} or to limits of 15.209	compliant
Band Edge Measurement	FCC Part 15.407(b)	RSS-210 part 6.2.2(o)(e1)	-20dB	compliant
Peak Power Spectral Density	FCC Part 15.407(a)	RSS-210 part 6.2.2(o)(b)	+4dBm - low band +11dBm-high band	compliant
Conducted Spurious Emissions	FCC Part 15.407(b)	RSS-210 part 6.2.2(o)(e1)	30 MHz – 40GHz	compliant
Radiated emissions and Transmitter radiated spurious emissions	FCC Part 15.205(a) FCC Part 15.209(a)	RSS-210 part 6.3	Emissions from 30MHz – 40GHz	compliant
Conducted Emissions	FCC Part 15.207	RSS-210 part 6.6	150kHz – 30MHz	compliant

1.4 Special Accessories or Equipment Modifications

The addition of some grounding straps were required to reduce harmonics to required levels. See photograph section for details.

2 Laboratory Information

2.1 Accreditations & Endorsements

2.1.1 US Federal Communications Commission

TUV Rheinland of North America at the 762 Park Ave. Youngsville, N.C 27596 address is accredited by the commission for performing testing services for the general public on a fee basis. This laboratory test facilities have been fully described in reports submitted to and accepted by the FCC (Registration No 90552 and 100881). The laboratory scope of accreditation includes: Title 47 CFR Part 15, 18, and 90. The accreditation is updated every 3 years.

2.1.2 NIST / NVLAP

TUV Rheinland of North America is accredited by the National Voluntary Laboratory Accreditation Program, which is administered under the auspices of the National Institute of Standards and Technology. The laboratory has been assessed and accredited in accordance with ISO Guide 25 and ISO 9002 (Lab code 200094-0). The scope of laboratory accreditation includes emission and immunity testing. The accreditation is updated annually.

2.1.3 Japan - VCCI

The Voluntary Control Council for Interference by Information Technology Equipment (VCCI) is a group that consists of Information Technology Equipment (ITE) manufacturers and EMC test laboratories. The purpose of the Council is to take voluntary control measures against electromagnetic interference from Information Technology Equipment, and thereby contribute to the development of a socially beneficial and responsible state of affairs in the realm of Information Technology Equipment in Japan. TUV Rheinland of North America at the 762 Park Ave. Youngsville, N.C 27596 address has been assessed and approved in accordance with the Regulations for Voluntary Control Measures. (Registration No. R-1174 and C-1236).

2.1.4 Acceptance By Mutual Recognition Arrangement

The United States has an established agreement with specific countries under the Asia Pacific Laboratory Accreditation Corporation (APLAC) Mutual Recognition Arrangement. Under this agreement, all TUV Rheinland of North America at the 762 Park Ave. Youngsville, N.C 27596 address test results and test reports within the scope of the laboratory NIST / NVLAP accreditation will be accepted by each member country.

2.2 Test Facilities

All of the test facilities are located at 762 Park Ave., Youngsville, North Carolina 27596, USA.

2.2.1 Emission Test Facility

The Open Area Test Site and AC Line Conducted measurement facility used to collect the radiated and conducted data has been constructed in accordance with ANSI C63.7:1992. The site has been measured in accordance with and verified to comply with the theoretical normalized site attenuation requirements of ANSI C63.4:1992, at a test distance of 3 and 10 meters. This site has been described in reports dated May 12, 1997, submitted to the FCC, and accepted by letter dated June 25, 1997 (31040/SIT 1300F2). The site is listed with the FCC and accredited by NVLAP (code 200094-0). The 5m semi-anechoic chamber used to collect the radiated data has been verified to comply with the theoretical normalized site attenuation requirements of ANSI C63.4:1992, at a test distance of 3 meters. A report detailing this site can be obtained from TUV Rheinland of North America.

2.3 Measurement Uncertainty

Two types of measurement uncertainty are expressed in this report, per *ISO Guide To The Expression Of Uncertainty In Measurement*, 1st addition, 1995.

The Combined Standard Uncertainty is the standard uncertainty of the result of a measurement when that result is obtained from the values of a number of other quantities, equal to the positive square root of a sum of terms, the terms being the variances or co-variances of these other quantities weighted according to how the measurement result varies with changes in these quantities. The term standard uncertainty is the result of a measurement expressed as a standard deviation.

The Expanded Uncertainty defines an interval about the result of a measurement that may be expected to encompass a large fraction of the distribution of values that could reasonably be attributed to the measurand. The fraction may be viewed as the coverage probability or level of confidence of the interval.

The test system for conducted emissions is defined as the LISN, spectrum analyzer, coaxial cables, and pads. The test system for radiated emissions is defined as the antenna, spectrum analyzer, pre-amplifier, coaxial cables, and pads. The conducted test system has a combined standard uncertainty of ± 1.2 dB. The radiated test system has a combined standard uncertainty of ± 1.6 dB. The expanded uncertainty at a level of 95% confidence is obtained by multiplying the combined standard uncertainty by a coverage factor of 2. Compliance criteria are not based on measurement uncertainty.

2.4 Calibration Traceability

All measurement instrumentation is traceable to the National Institute of Standards and Technology (NIST). Measurement method complies with ANSI/NCSL Z540-1-1994 and ISO Guide 25.

3 Product Information



Figure 1 – Photo of EUT (Provided by Manufacturer)

3.1 Product Description

The information for all equipment used in the tested system, including: descriptions of cables, clock and microprocessor frequencies, EMI critical components, and accessory equipment has been supplied by the manufacturer.

3.2 Equipment Configuration

A description and justification of the equipment configuration is given in the EMC Test Plan. The EUT was tested as described in the EMC Test Plan and was configured and operated in a manner consistent with its intended use. The EUT was connected to rated power and allowed to warm up to normal operating conditions. The placement of the EUT system components was guided by the test standard and selected to represent typical installation conditions.

In the case of an EUT that can operate in more than one configuration, preliminary testing was performed to determine the configuration that produced maximum radiation.

The final configuration was selected to produce worse case radiation and place the EUT in the most susceptible state. There were no deviations from the description of the Equipment Configuration given in the EMC Test Plan.

3.3 Operation Mode

A description and justification of the operation mode is given in the EMC Test Plan.

In the case of a EUT that can operate in more than one state, preliminary testing was performed to determine the operating mode that produced maximum radiation.

The final operating mode was selected to produce worse case radiation and place the EUT in the most susceptible state. There were no deviations from the description of the Operation Mode given in the EMC Test Plan.

Some experimentation showed that the harmonics and band widths were beyond limit at full power output. The software (ART) was used to lower the output power by 4 dB (ART value from 18 to 14). The manufacturer affirmed that the production units will be set to this value, and that this function is not accessible to the end user.

4 Emissions

Testing was performed in accordance with 47 CFR Part 15, ANSI C63.4:1992, RSS-210 Issue 6. These test methods are listed under the laboratory’s NVLAP Scope of Accreditation. This test measures the levels emanating from the EUT, thus evaluating the potential for the EUT to cause radio frequency interference to other electronic devices.

Radio Specs-802.11a

Frequency Bands

- 5.150 ~ 5.250 GHz (lower band)
- 5.250 ~ 5.350 GHz (middle band)
- 5.725 ~ 5.825 GHz (higher band)

4.1 26dB and 99% Bandwidth; §15.407(a), RSS-210 §6.2.2(q1)(i-iii)

The bandwidths are measured with a spectrum analyzer connected directly to the antenna termination, while the EUT is operating in transmission mode at the appropriate center frequency. Since the bin width is less than 0.5 RBW and the analyzer has 500 measurement points in the spectrum display, the sample detector was selected.

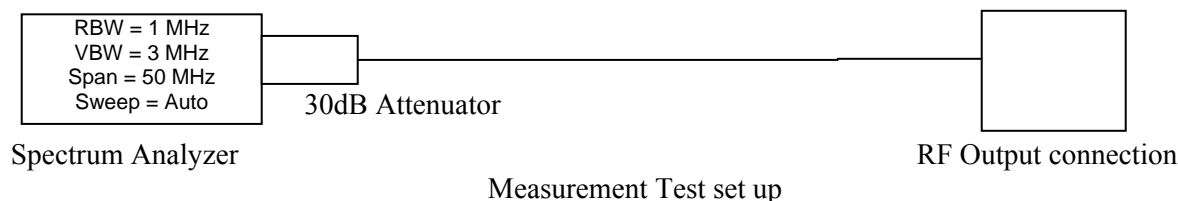

Table 2 – Bandwidth

802.11a 5.15 -5.25GHz Band		
Center Frequency (GHz)	26dB Bandwidth (MHz)	99% Bandwidth (MHz)
5.18 - low	24.950	17.535
5.21 - mid	23.948	17.535
5.24 - high	20.942	17.335

802.11a 5.25 -5.35GHz Band		
Center Frequency (GHz)	26dB Bandwidth (MHz)	99% Bandwidth (MHz)
5.28 - low	20.441	17.234
5.30 - mid	20.441	17.331
5.32 - high	20.441	17.234

Notes: Emission shown in **red** is worst case, see plots below.

Refer to TUV Test report #30660840.002 for test results in the 5.725 – 5.825GHz Band.

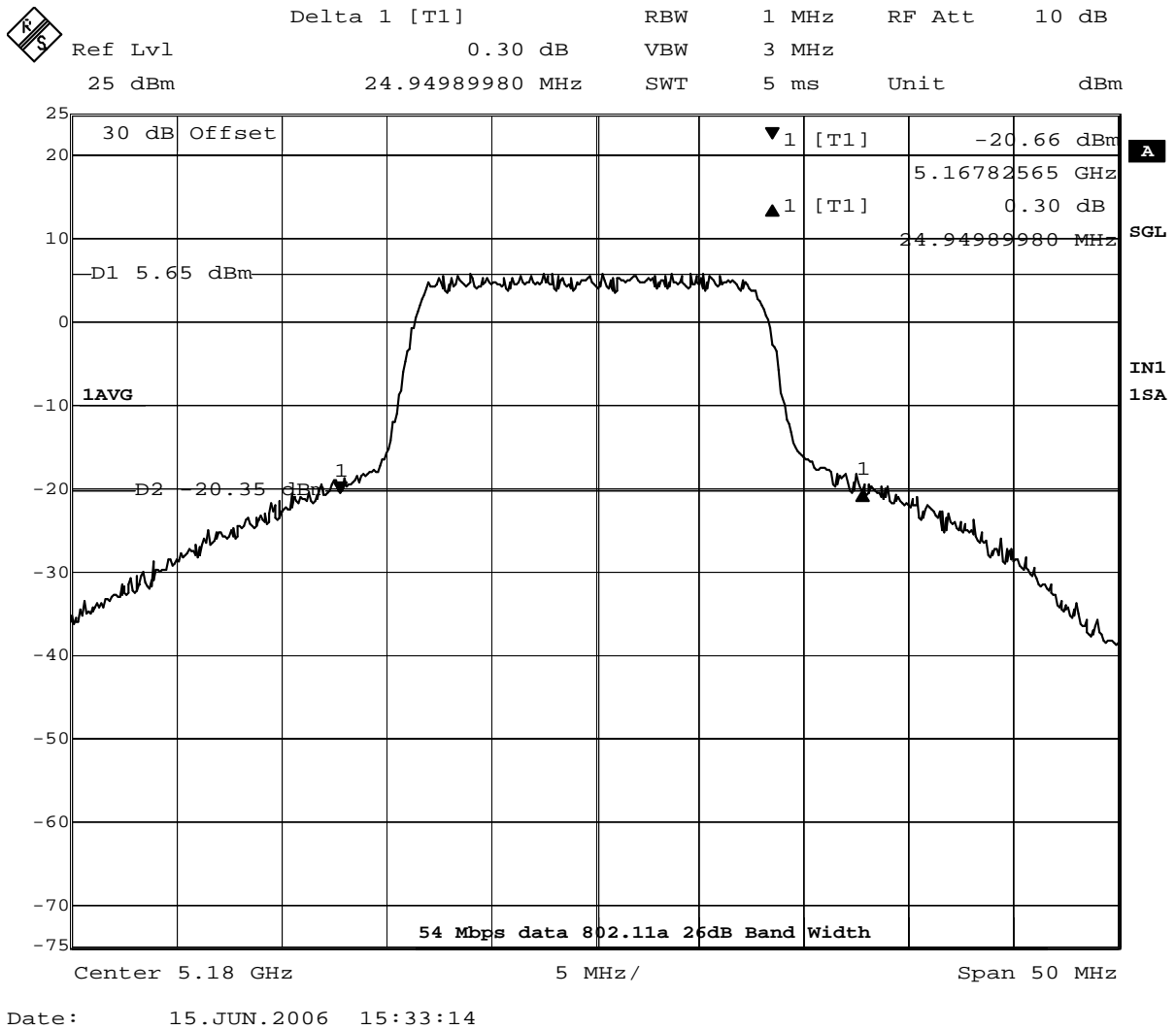

Note: plots for mid and high band are on file at TUV Rheinland – Raleigh office.

Figure 2 - Plot of 802.11a - 26dB bandwidth at 5.18GHz

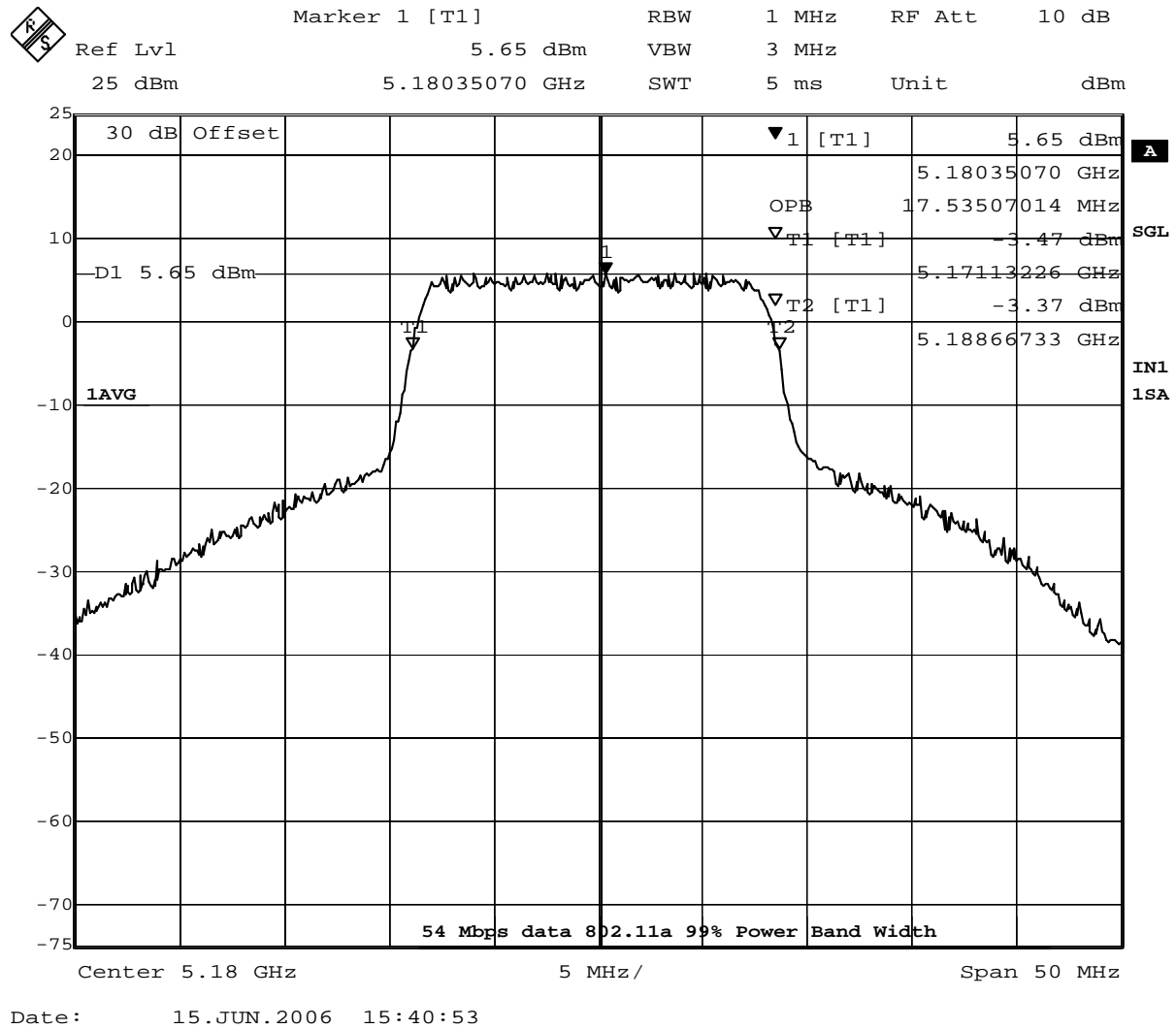

Note: plots for mid and high band are on file at TUV Rheinland – Raleigh office.

Figure 3 - Plot of 802.11a – 99% bandwidth at 5.18GHz

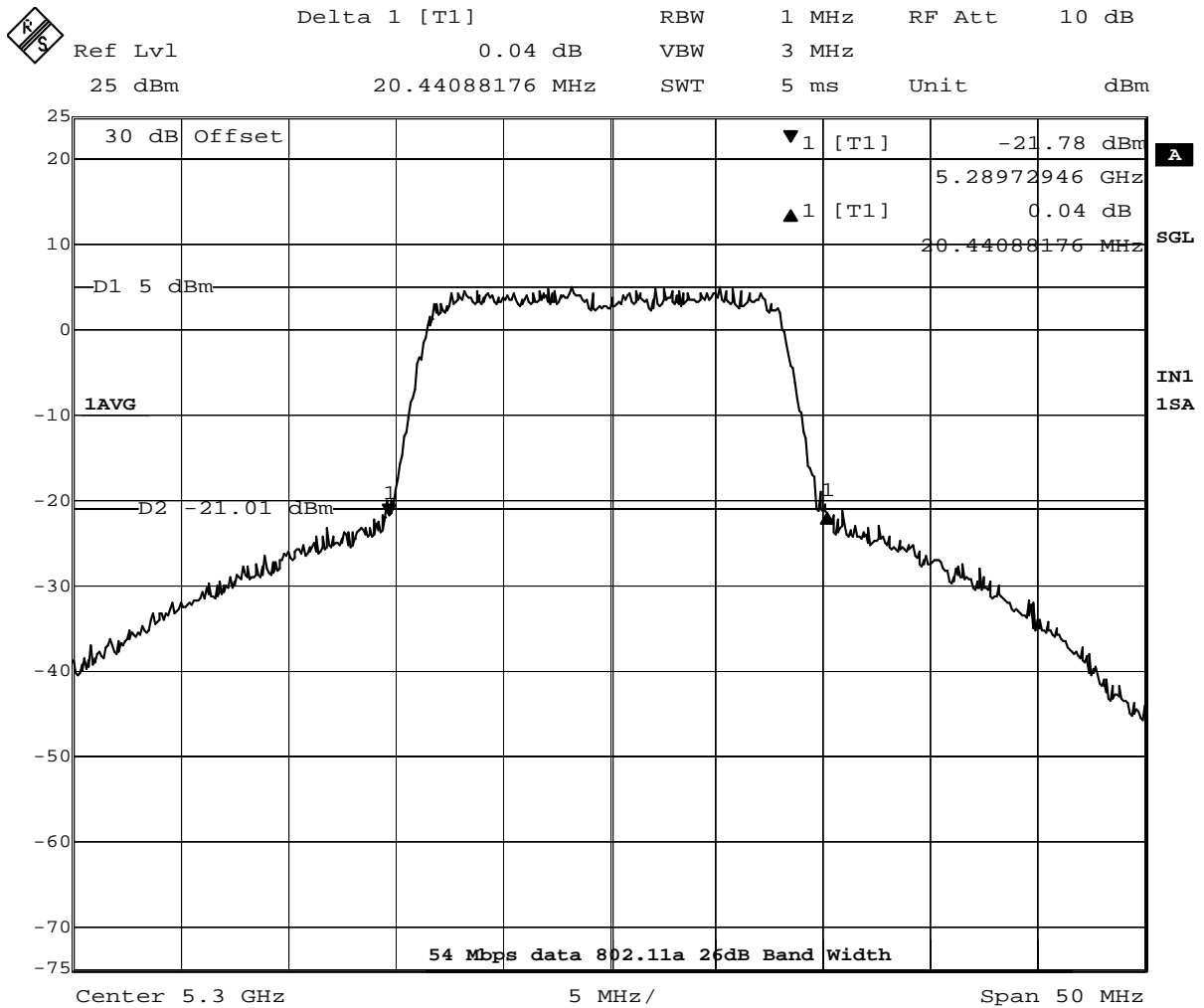

Date: 15.JUN.2006 16:25:23

Note: plots for low and high band are on file at TUV Rheinland – Raleigh office.

Figure 4 - Plot of 802.11a - 26dB bandwidth at 5.30GHz

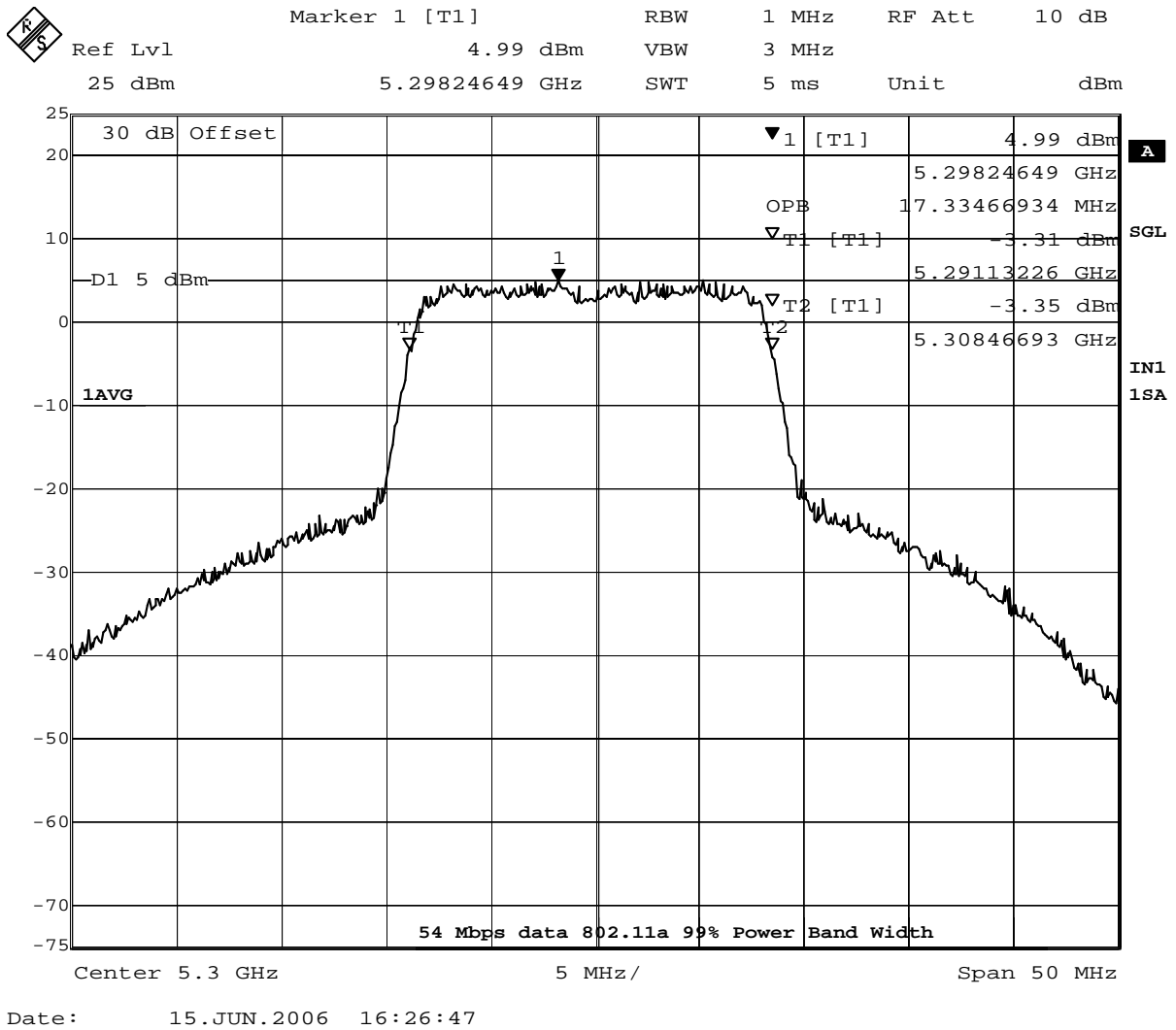

Note: plots for low and high band plots are on file at TUV Rheinland – Raleigh office.

Figure 5 - Plot of 802.11a – 99% bandwidth at 5.30GHz

Refer to Test report 30660840.002 for test results in the 5.725 – 5.825GHz Band

4.2 Output Power; FCC §15.407(a), RSS-210 §6.2.2(q1)

The transmitter output was connected to the input of a spectrum analyzer. The measurement is made while the EUT is operating in a continuous transmission mode at the appropriate center frequency. Since the bin width is less than 0.5 RBW and the analyzer has 500 measurement points in the spectrum display, the sample detector was selected. The spectrum analyzer built-in power function was used to measure peak power for the 26dB emission bandwidth. The procedure used FCC Public Notice # DA 02-2138 method #1 for peak power.

The average power was also measured but utilizing the analyzer's average power detector.

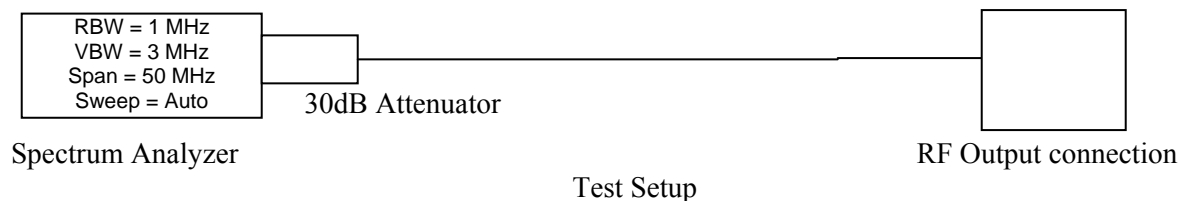

Table 3 – Peak Output Power

802.11a 5.15 -5.25GHz Band			
Center Frequency	26dB Bandwidth (MHz)	Peak Power (dBm)	Ave. Power (dBm)
5.18 GHz	24.950	16.38	5.95
5.21 GHz	23.948	16.44	5.96
5.24 GHz	20.942	15.23	5.92

802.11a 5.25 -5.35GHz Band			
Center Frequency	26dB Bandwidth (MHz)	Peak Power (dBm)	Ave. Power (dBm)
5.28 GHz	20.441	14.81	5.56
5.30 GHz	20.441	15.19	5.51
5.32 GHz	20.441	15.17	5.64

Notes: Emissions shown in red are highest emissions, see plots below

Refer to Test report 30660840.002 for test results in the 5.725 – 5.825GHz Band

4.2.1 Supply Voltage Variation

The supply voltage was varied between 97.75 and 132.25 VAC. The system operated as intended at either extreme with no change in the above bandwidths.

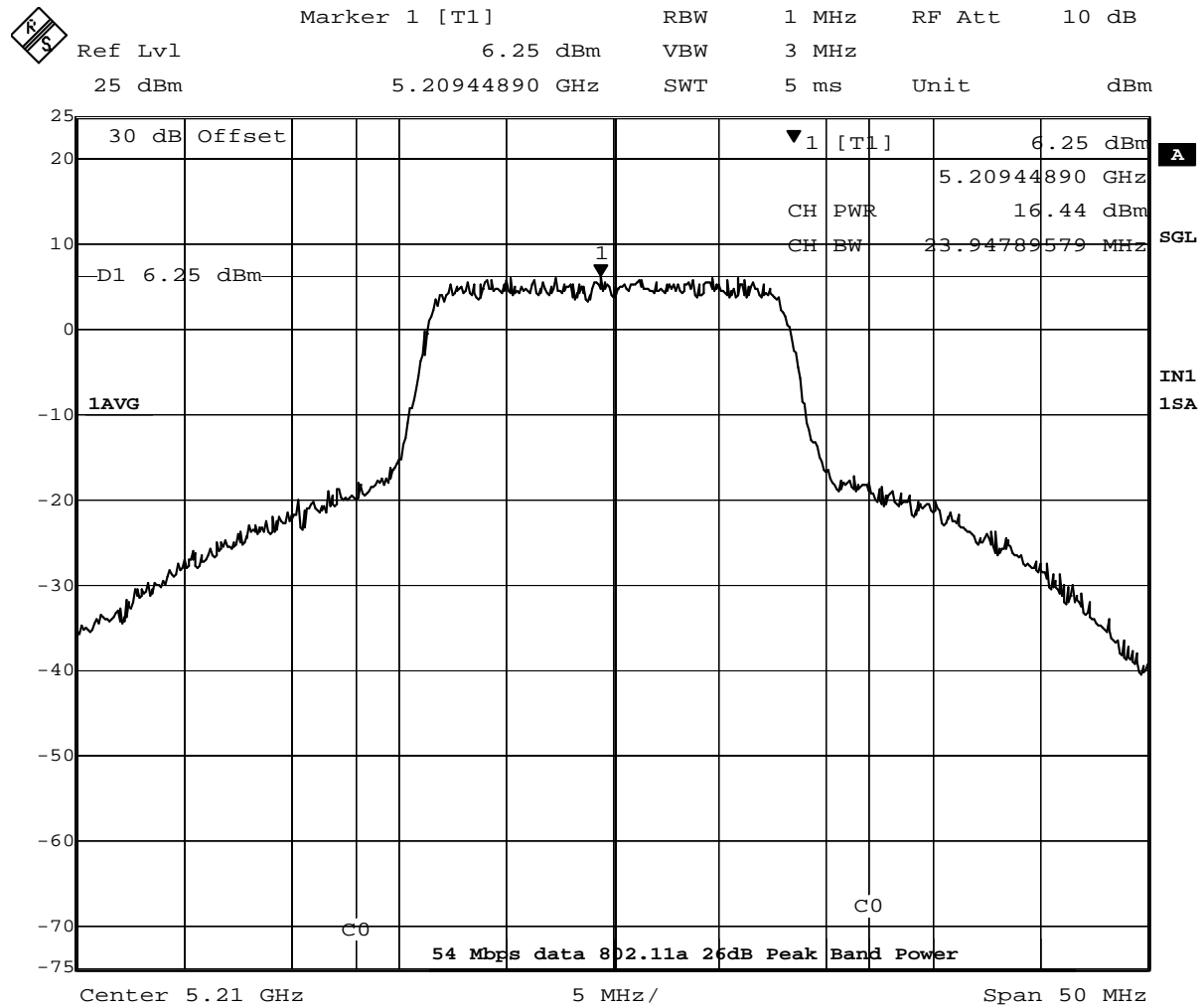

Date: 15.JUN.2006 15:50:14

Note: plots for low and high band are on file at TUV Rheinland – Raleigh office.

Figure 6 - Plot of 802.11a – 26dB Peak Band Power at 5.30GHz

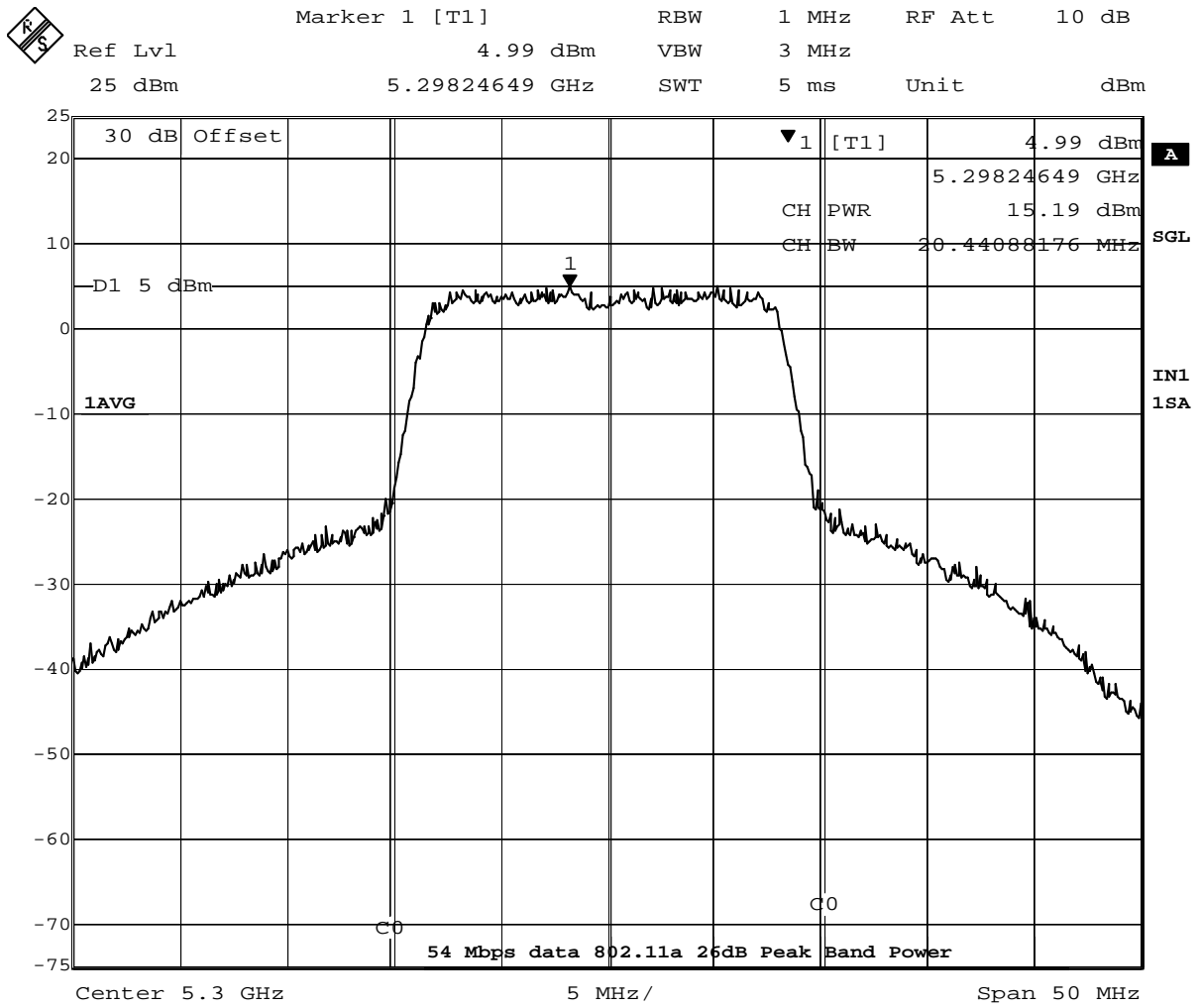

Date: 15.JUN.2006 16:28:43

Note: plots for low and high band are on file at TUV Rheinland – Raleigh office.

Figure 7 - Plot of 802.11a – 26dB Peak Band Power at 5.30GHz

4.2.2 Power Limits

Maximum Power Calculation

FCC Power Limits

Frequency Band (MHz)	FCC Limit shall not exceed the lesser of;	Maximum Observed 26dB Bandwidth (MHz)	Power Limit (dBm)
5150 - 5250	50mW (+17dBm) or 4dBm + 10log ₁₀ B	24.950	+17.0 or 17.97
5250 - 5350	250mW (+24dBm) or 11dBm + 10log ₁₀ B	20.441	+24.0 or 24.11

Industry Canada Power Limits

Frequency Band (MHz)	FCC Limit shall not exceed the lesser of;	Maximum Observed 99% Bandwidth (MHz)	Power Limit
5150 - 5250	200mW (+23dBm) or 10dBm + 10log ₁₀ B	17.535	+23.0 or 22.43
5250 - 5350	250W (+30dBm) or 11dBm + 10log ₁₀ B	17.331	+25.0 or 23.39

Note: the power limit in **RED** is the lower level of the two, and is therefore the power limit.

Refer to TUV test report #30660840.002 for test results in the 5725-5825GHz band.

4.2.3 Antenna Gain

If peak power output was performed using the conducted method then the antenna gain will be stated.

The Conducted method was used. The transmitting antennas do not have gains greater than 6dBi. Therefore per FCC §15.407(b)(1-3), the intentional radiator's power output need not be reduced, and the maximum peak output power of the intentional radiator will remain at the above levels. The following antenna data was provided by the applicant:

The EUT uses two dual-band, vertically polarized antennas. The antennas are supplied by a third party, with the following maximum gains: 5.250GHz: 3.9dBi, and 5.875GHz: 4.9dBi

The antenna structure utilizes a dipole-like structure for each band and is thus ground independent. The dual antennas allow switched diversity, however antenna combining and/or active beam-forming is not possible (only one antenna may transmit at a time for each band).

The procedure used FCC Public Notice # DA 02-2138 for peak power. The transmitter output was connected to the input of a spectrum analyzer. The measurement is made while the EUT is operating in a continuous transmission mode at the appropriate center frequency. The EIRP of the EUT is the sum of the conducted power measurement and stated antenna gain.

Power Limit References

§15.407(a) For the following frequency bands the peak transmit power over the following range of operation shall not exceed the lesser of:

- (1) 5.15-5.25GHz; 50mW (+17dBm) or $4\text{dBm} + 10\log_{10}B$, where B is the 26dB BW in MHz .
- (2) 5.25-5.35GHz; 250mW (+24dBm) or $11\text{dBm} + 10\log_{10}B$, where B is the 26dB BW in MHz .
- (3) 5.725-5.825GHz; 1W (+30dBm) or $17\text{dBm} + 10\log_{10}B$, where B is the 26dB BW in MHz .

RSS-210 §6.2.2(q1)(i-iii)

- (i) 5.15-5.25GHz (indoor use only) – The maximum equivalent isotropically radiated power (EIRP) shall not exceed 200mW or $10 + 10\log_{10} B$ dBm, whichever power is less. B is the 99% power Bandwidth in MHz.
- (ii) 5.25-5.35GHz – The maximum power shall not exceed 250mW or $11 + 10\log_{10} B$ dBm, whichever power is less. The maximum EIRP shall not exceed 1.0 watt or $17 + 10\log_{10} B$ dBm, whichever power is less. B is the 99% power Bandwidth in MHz.

Notes: Section 6.2.2(q1)(iv)(b) permits the use of a 26dB bandwidth as an alternative.

Refer to TUV test report #30660840.002 for test results in the 5725-5825GHz band.

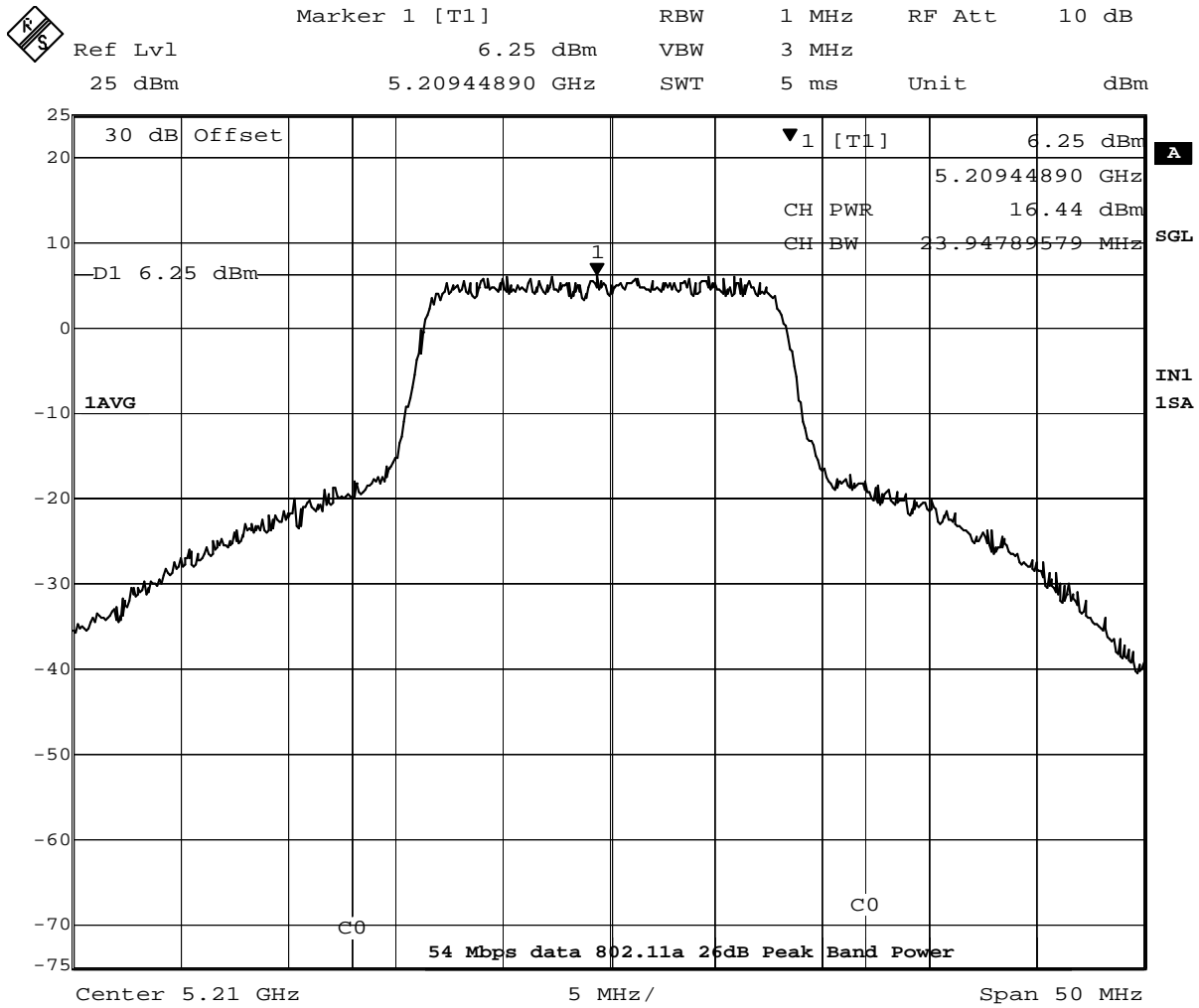

Date: 15.JUN.2006 15:50:14

Figure 8 – Peak Power Output for 802.11a - 5150 – 5250MHz

Note: plots for low and high band are on file at TUV Rheinland – Raleigh office.

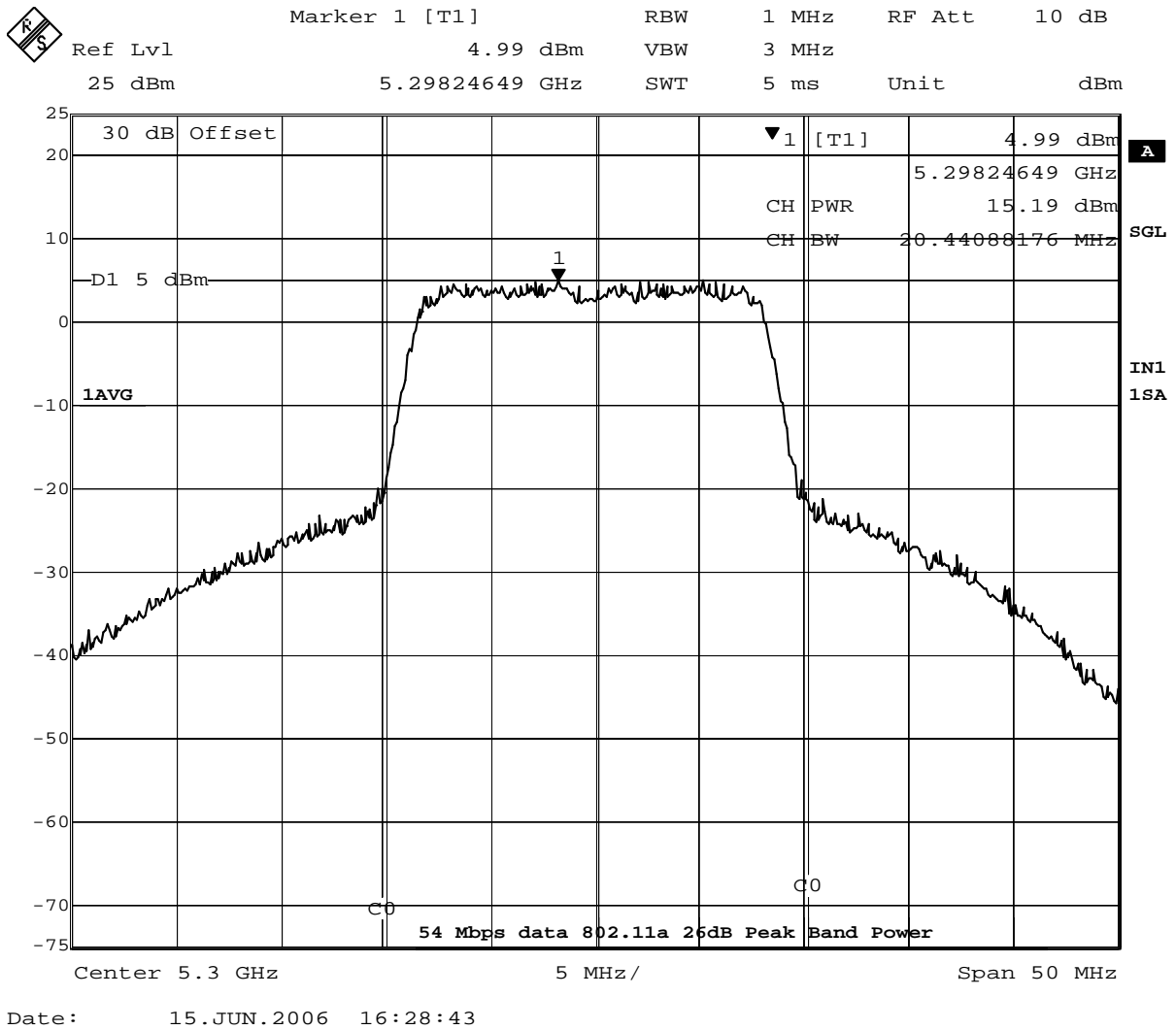

Figure 9 – Peak Power Output for 802.11a - 5250 – 5350MHz

Note: plots for low and high band are on file at TUV Rheinland – Raleigh office.

Refer to TUV test report #30660840.002 for test results in the 5725-5825GHz band.

4.3 Frequency Stability FCC Part 15.407(g), RSS-210 Part 6.2.2.(q1)(iv)(g)

4.3.1 Test procedure

The manufacturer of the equipment is responsible for ensuring that the frequency stability is such that emissions are always maintained within the band of operation under all conditions.

4.3.2 Manufacturer Declaration

The frequency stability of the reference oscillator sets the frequency stability of the RF transceiver signals. Therefore all of the RF signal should have ± 20 ppm stability.

This stability accounts for room temp tolerance of the crystal oscillator circuit, frequency variation across temperature, and crystal ageing.

Worst case:

5.150GHz - ± 20 ppm/103kHz

± 20 ppm at 5.150GHz translates to a maximum frequency shift of ± 103 kHz. As the edge of the channels are at least one MHz from either of the band edges, ± 103 kHz is more than sufficient to guarantee that the intentional emission will remain in the band over the entire operating range of the radio.

4.3.3 Voltage Variation

The ac supply voltage was varied between 85% and 115% of the nominal rated supply voltage. No change in fundamental frequency was observed during the variation. The equipment was found to be compliant.

4.3.4 Temperature Testing

The EUT was placed in a temperature chamber that was increased in 10°C steps from the extremes of equipment operation (0°C to +50°C). No change in fundamental frequency was observed during this period. The equipment complied with the specification.

4.4 Maximum Permissible Exposure; FCC §15.407(f), RSS-210 §6.2.2(q1)(iv)(g)

4.4.1 Maximum Permissible Exposure Limits

The EUT shall be operated in a manner that ensures that the public is not exposed to radio frequency levels in excess of the FCC guidelines, per FCC §1.307(b)(1).

1.5GHz to 100GHz, the Limit $S = 1\text{mW}/\text{cm}^2$ for no more than 30 minutes exposure from Table 1 of FCC §1.1310.

4.4.2 Calculations for Maximum Permissible Exposure Levels

Given:

$$E = \sqrt{(30 * p * G)} / d$$

And

$$S = E^2 / 3770$$

Where:

E = field strength in volts/meter

P = power in watts

G = numeric antenna gain

D = distance in meters

S = power density in milliwatts / cm^2

Combining and rearranging the terms to express the distance as function of the variables, yields:

$$d = \sqrt{(30 * p * G)} / 1000$$

$$d(\text{cm}) = d(\text{m}) * 100$$

Yields:

$$d = 100 * \sqrt{(30 * (P/1000) * G)} / (3770 * s)$$

$$d = 0.282 * \sqrt{(P * G / S)}$$

Where:

d = distance in cm

P = power in mW

G = numeric antenna gain

S = Power Density in cm^2

Substituting the logarithmic form of power and gain using:

$$P(\text{mW}) = 10^{(P9\text{dBm})/10} \quad \text{and} \quad G(\text{numeric}) = 10^{(G(\text{dBi})/10)}$$

Yields:

$$d = 0.282 * 10^{((P + G) / 20)} * \sqrt{S}$$

Where:

=MPE distance in cm

P = Maximum measured output Power in dBm = +16.44dBm (from table 3 above)

G = Antenna Gain in dBi 3.9dBi (from antenna manufacturer specification sheet for that frequency)

S = Power Density Limit in $\text{mW}/\text{cm}^2 = 1\text{mW}/\text{cm}^2$ (from Table 1 of FCC §1.1310).

1.1.1.1 Results

The minimum safe distance from the EUT is 2.9 cm for no more than 30 minutes of continuous exposure.

Table 4 – MPE Distance calculation

802.11a			
Power Density Limit (mW/cm^2)	Maximum Measured Output Power (dBm)	Antenna Gain (dBi)	MPE Distance (cm)
1	+16.44	+3.9	<u>2.9</u>

Refer to TUV test report #30660840.002 for test results in the 5725-5825GHz band.

4.5 Band-Edge Measurement FCC §15.407(b), RSS-210 §6.2.2(o)(e1)

4.5.1 Test Procedure

The direct measurement method was used where the band-edge is measured at 20dB below the highest in-band density measured with a spectrum analyzer connected directly to the antenna terminal of the transmitter, while the EUT is operating in continuous transmissions mode at the appropriate center frequencies.

The 5150 and 5350MHz band edges are also the FCC restricted band edges. Since the restricted band edge has lower limits, only the restricted band edge measurements will be performed.

Emissions band-edge measurements were made at the 5150 and 5350 MHz restricted band edges in accordance with the requirements of §15.205 using the limits in §15.209.

Test Setup:

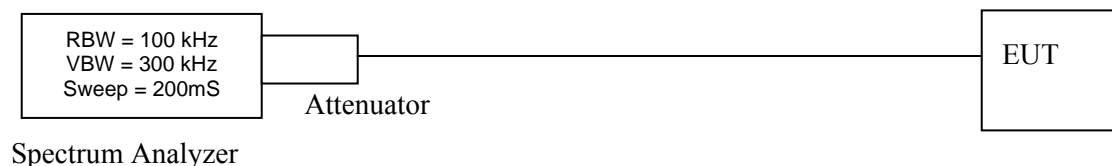
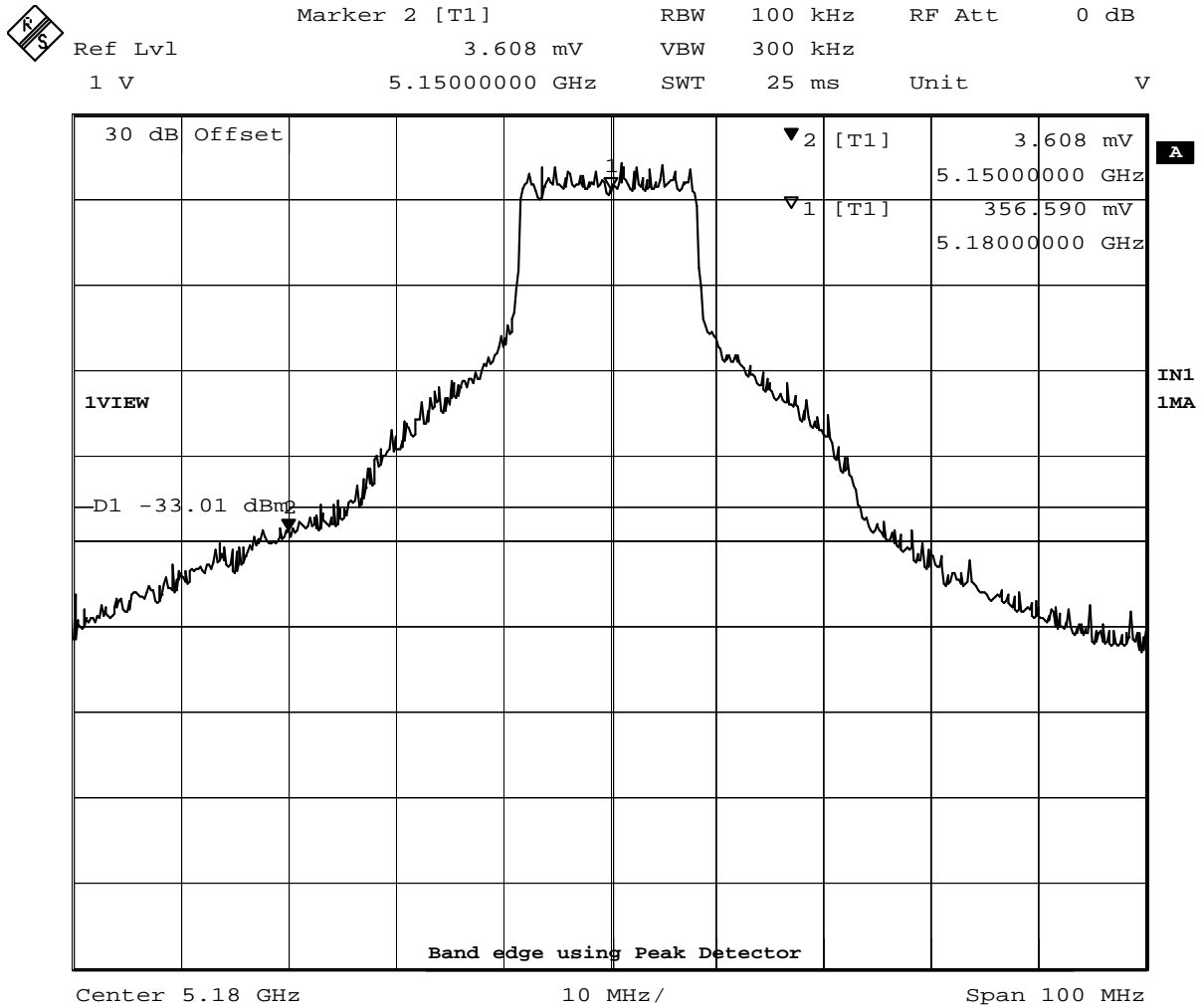

Table 5 — Band-Edge Results

Restricted band edge:							
Center Frequency (MHz)	Band Edge (MHz)	Amplitude at restricted band (μV)Pk	Amplitude at restricted band (μV)Av	Peak Limit at restricted band (μV)	Average Limit at restricted band (μV)	Margin to Peak Limit (μV)	Margin to Av. Limit (μV)
5180	5150	3608	144	5000	500	1392	356
5320	5350	1175	147	5000	500	3825	353

Note: The restricted band edge measurement was performed using the provision of FCC§15.35(b), the peak and average limits were used for this test. The peak limit is calculated to be 20dB higher than the average limit. The average limit at the restricted band is 500μV or -53dBm (at 50Ω).

Therefore -53dBm + 20dB is -33dBm, or 5000μV (5mV).



Date: 28.JUN.2006 20:09:12

Figure 10 – 802.11a at 5150MHz Restricted Band edge using Peak Detector



Marker 2 [T1] RBW 100 kHz RF Att 10 dB
 Ref Lvl 144.490 μ V VBW 300 kHz
 300 mV 5.1500000 GHz SWT 25 ms Unit V

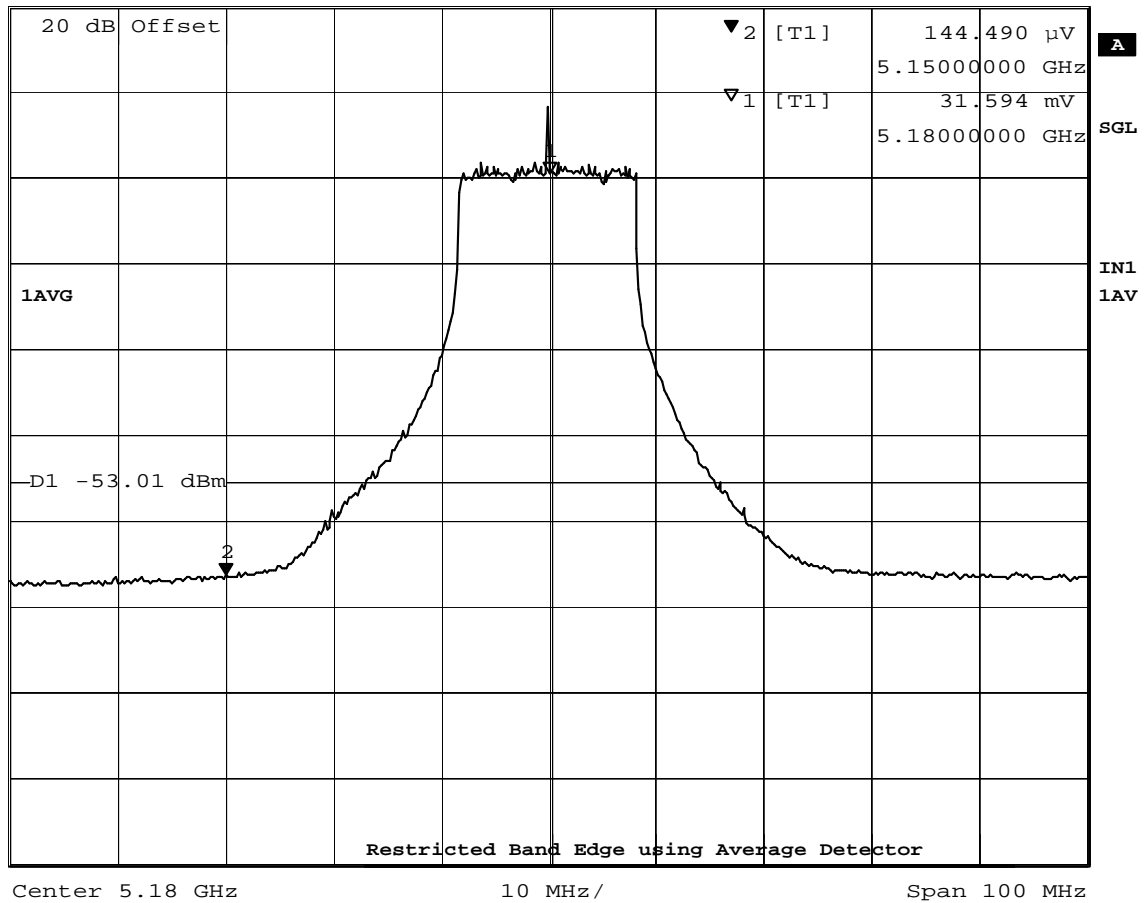

Date: 28.JUN.2006 20:21:30

Figure 11 – 802.11a at 5150MHz Restricted Band edge using Average Detector



	Marker 2 [T1]	RBW	100 kHz	RF Att	0 dB
Ref Lvl	1.175 mV	VBW	300 kHz		
1 V	5.3500000 GHz	SWT	25 ms	Unit	V

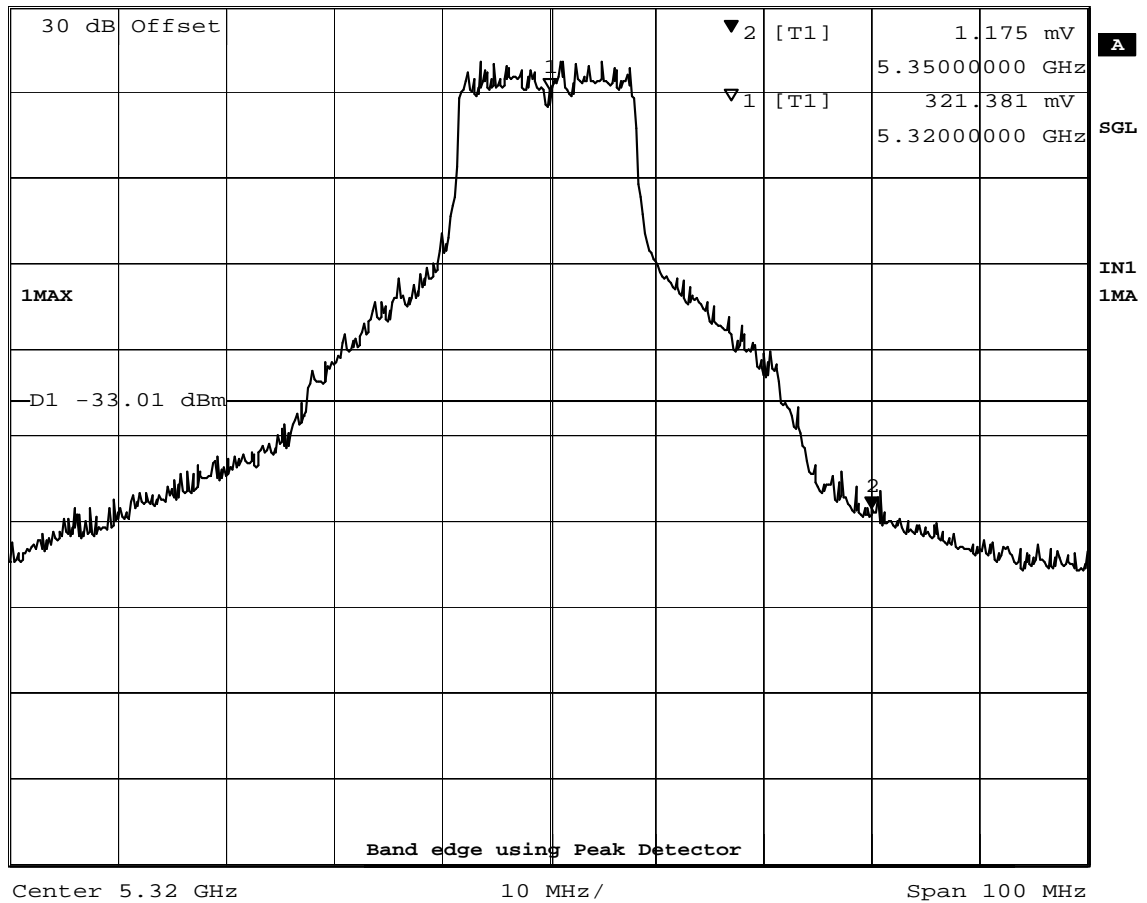

Date: 28.JUN.2006 20:06:08

Figure 12 – 802.11a at 5320MHz Restricted Band edge using Peak Detector



Marker 2 [T1] RBW 100 kHz RF Att 10 dB
 Ref Lvl 33.773 mV VBW 300 kHz
 300 mV 5.3200000 GHz SWT 25 ms Unit V

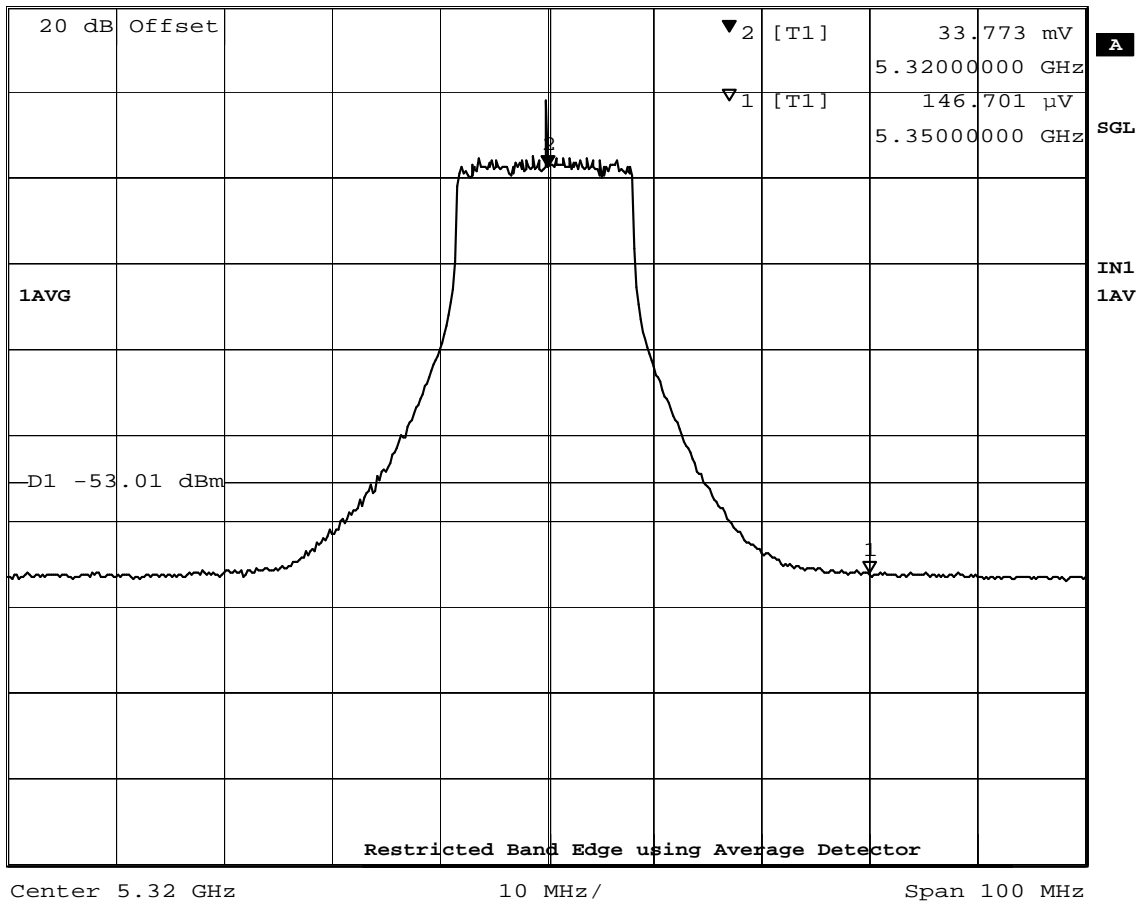

Date: 28.JUN.2006 20:24:19



Marker 1 [T1] RBW 100 kHz RF Att 10 dB
 Ref Lvl 146.701 μ V VBW 300 kHz
 300 mV 5.3500000 GHz SWT 25 ms Unit V

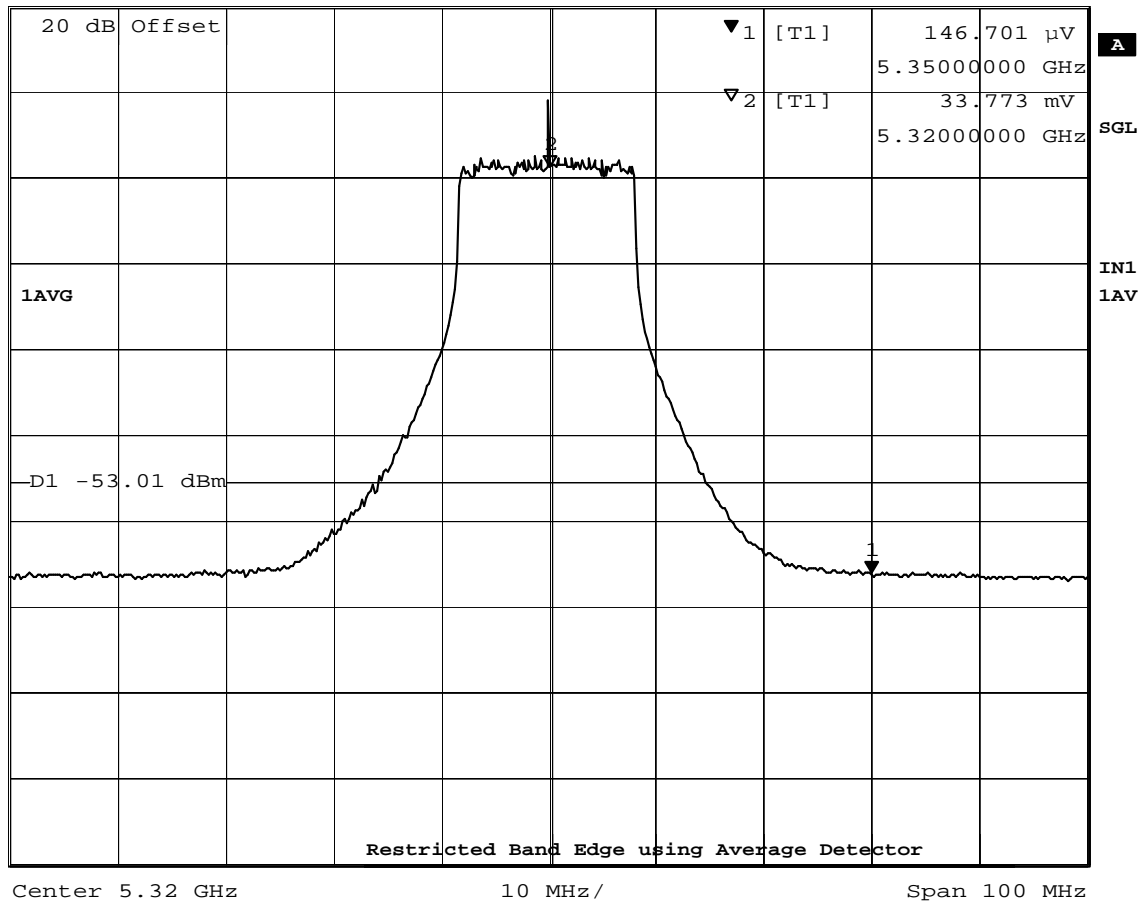

Date: 28.JUN.2006 20:35:57

Figure 13 – 802.11a at 5320MHz Restricted Band edge using Average Detector

4.6 Peak Excursion Ratio; FCC §15.407(a)(6)

4.6.1 Test Procedure

The EUT transmitter is connected directly to a spectrum analyzer using 30dB of external attenuation. The Peak Excursion Ratio is the difference in amplitude (dB) between the average measurement and peak measurements. The difference shall not exceed 13dB. The Peak Excursion measurement was performed according to procedures in DA02-2138; Aug 30, 2002.

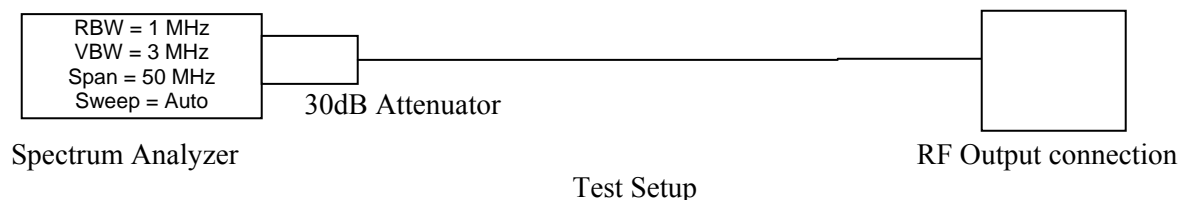

4.6.2 Measurement Results for Peak Excursion Ratio

Table 6 – 802.11a; 5.15 - 5.25 GHz Band

Center Frequency (GHz)	Peak Trace 1 (dBm)	Peak Trace 2 (dBm)	Measured Excursion Ration (dB)	Margin to 13dB limit (dB)
5.18	17.83	6.57	11.26	1.74
5.21	17.57	6.41	11.16	1.84
5.24	16.36	5.81	10.55	2.45

802.11a; 5.25 - 5.35 GHz Band

Center Frequency (GHz)	Peak Trace 1 (dBm)	Peak Trace 2 (dBm)	Measured Excursion Ration (dB)	Margin to 13dB limit (dB)
5.28	16.56	6.17	10.39	5.61
5.30	16.14	5.32	10.82	2.18
5.32	16.66	6.22	10.44	5.56

802.11a; 5.725 - 5.825 GHz Band

Center Frequency (GHz)	Peak Trace 1 (dBm)	Peak Trace 2 (dBm)	Measured Excursion Ration (dB)	Margin to 13dB limit (dB)
5.745	15.00	4.61	10.39	2.61
5.785	13.97	3.27	10.7	2.30
5.825	15.46	4.49	10.97	2.03

Notes: Emissions shown in **red** are highest emissions, see plots below

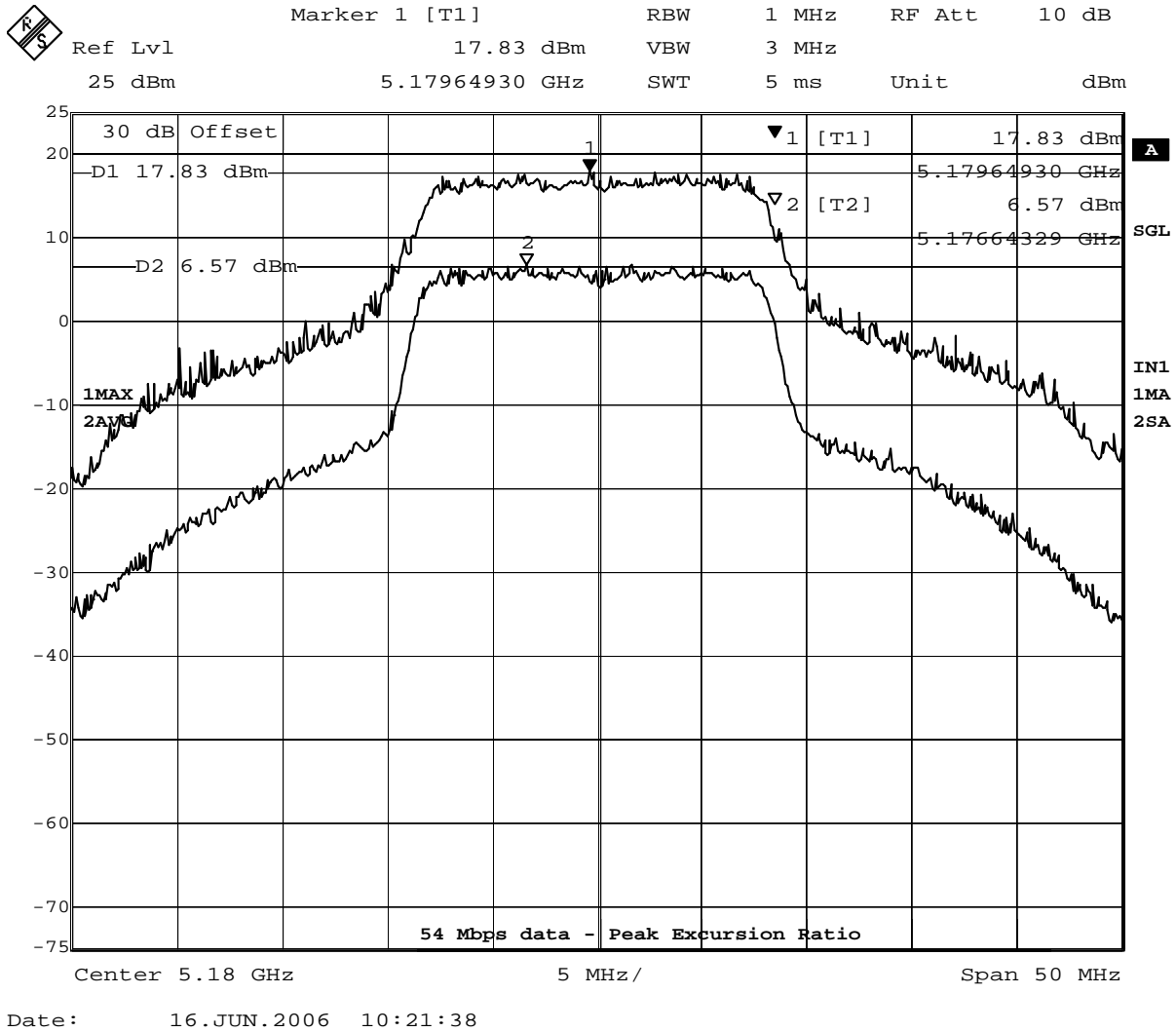

Figure 14 – 802.11a Peak Excursion Ratio; 5.15 – 5.24 GHz band

Note: plots for mid and high band are on file at TUV Rheinland – Raleigh office.

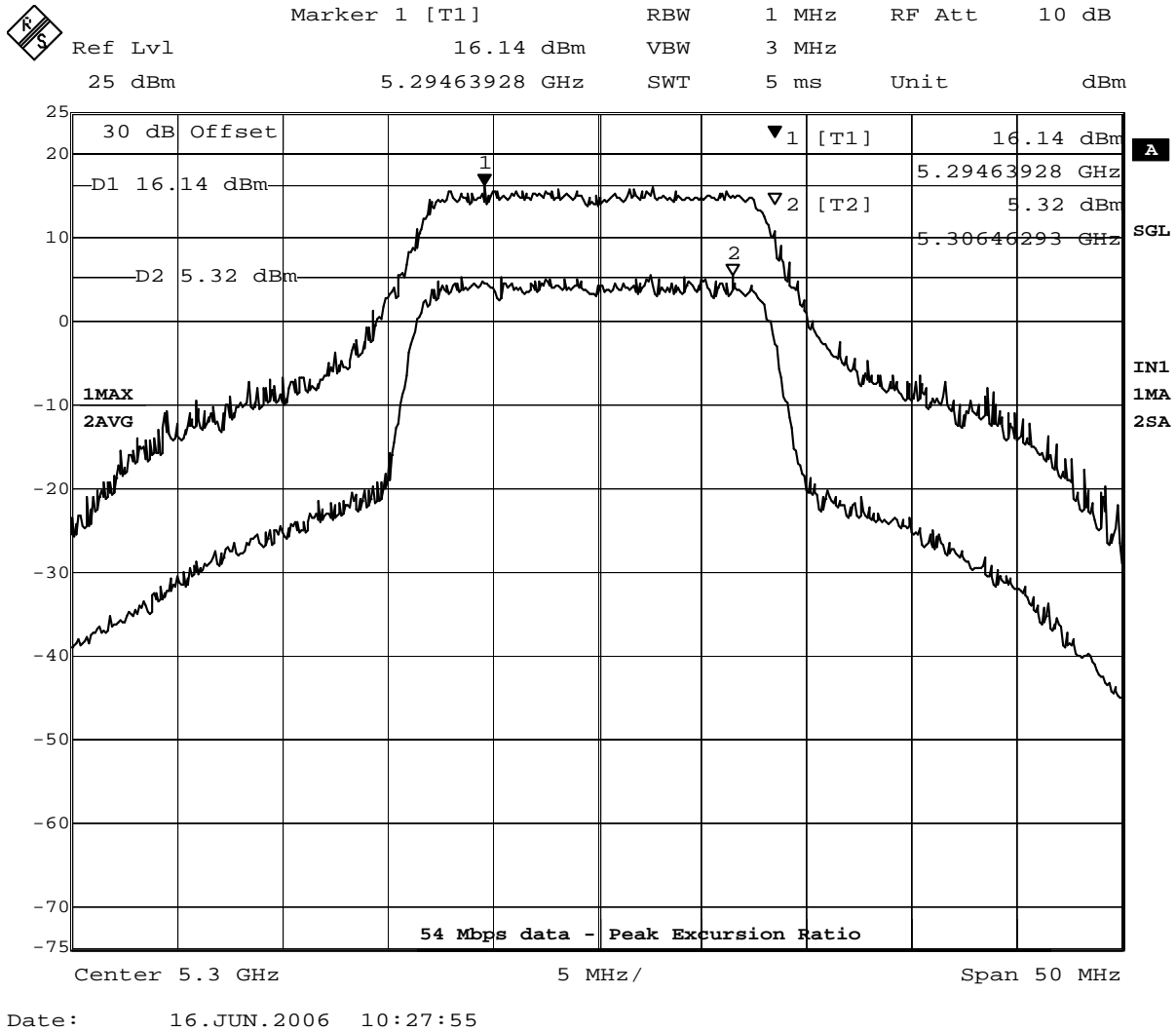

Figure 15 – 802.11a Peak Excursion Ratio; 5.15 – 5.24 GHz band

Note: plots for low and high band are on file at TUV Rheinland – Raleigh office.

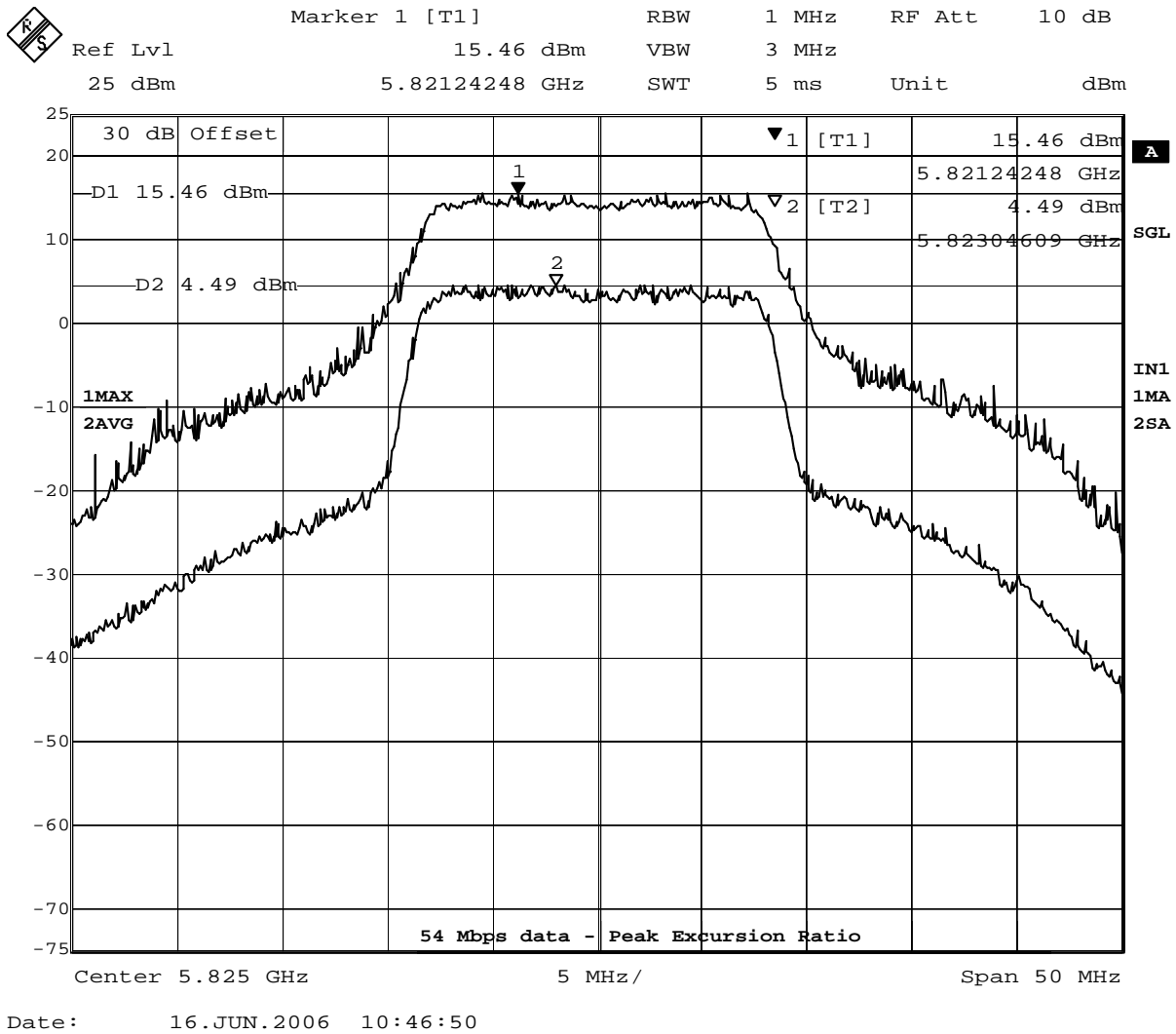

Figure 16 – 802.11a Peak Excursion Ratio; 5.725 – 5.825 GHz band

Note: plots for low and high band are on file at TUV Rheinland – Raleigh office.

4.7 Conducted Spurious Emissions; FCC §15.407(b), RSS-210 §6.2.2(o)(e1)

4.7.1 Test Procedure

Undesirable emissions are measured with a spectrum analyzer connected directly to the antenna terminal. Measurements on any frequency or frequencies over 1GHz are based on the use of measurement instrumentation employing an average detector function. All measurements above 1GHz were performed using a minimum resolution bandwidth of 1MHz.

4.7.2 Measurement Results of Conducted Spurious Emissions

Table 7 – 802.11a Peak Conducted Spurious Emissions

Start Frequency (GHz)	Stop Frequency (GHz)	Max. Emission Observed (dBm/MHz)	Margin to -27dBm Limit (dB)
Low Band (5.18GHz Transmitting frequency)			
0.30	4	-55.60	-28.60
4	5.15	-30.85	-3.85
5.825	7	-47.31	-20.31
7	13	-45.97	-18.97
13	26	-55.00	-28.00
26	40	-63.47	-36.47
Mid Band (5.32GHz Transmitting frequency)			
0.30	4	-54.1	-27.1
4	5.15	-48.57	-21.25
5.825	7	-39.89	-12.89
7	13	-44.08	-17.08
13	26	-54.18	58.18
26	40	-63.98	-36.98
High Band (5.805GHz Transmitting frequency)			
0.30	4	-56.14	-29.14
4	5.15	-44.99	-17.99
5.825	7	-44.62	-17.62
7	13	-45.01	-18.01
13	26	-57.06	-30.06
26	40	-64.02	-37.02

Note: Measurement in red is worst case

The plots show below is for worst case emissions.
 The plots for mid band and high band are on file at TUV Rheinland – Raleigh NC office.

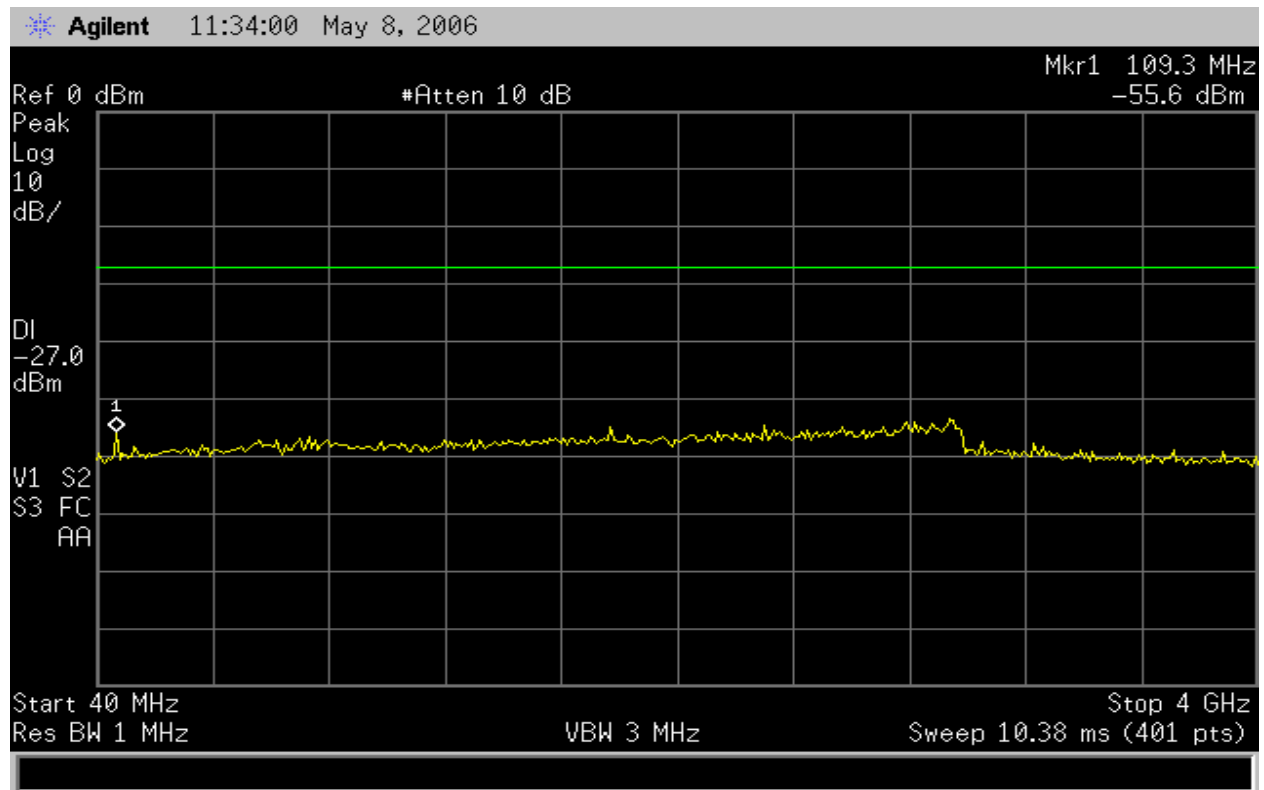

Figure 17 – 802.11a Conducted Spurious emissions worst case at 5.18GHz Transmit frequency

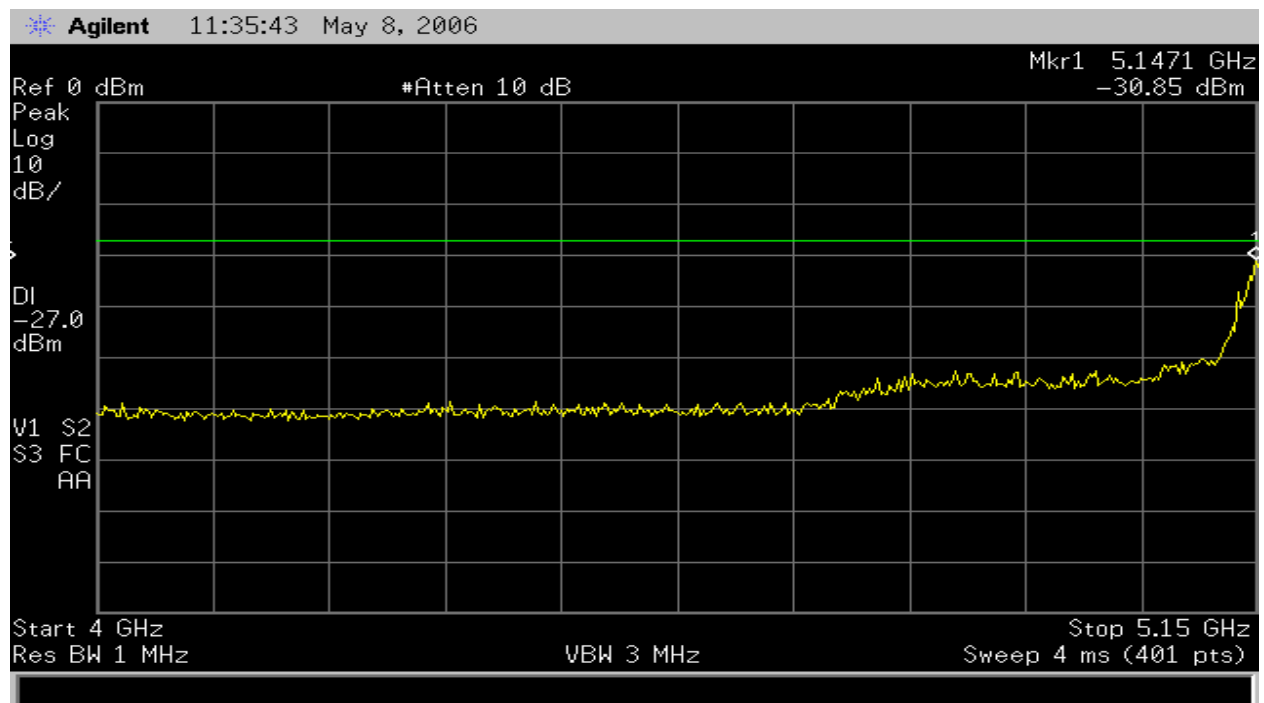

Figure 18 – 802.11a Conducted Spurious emissions worst case at 5.18GHz Transmit frequency

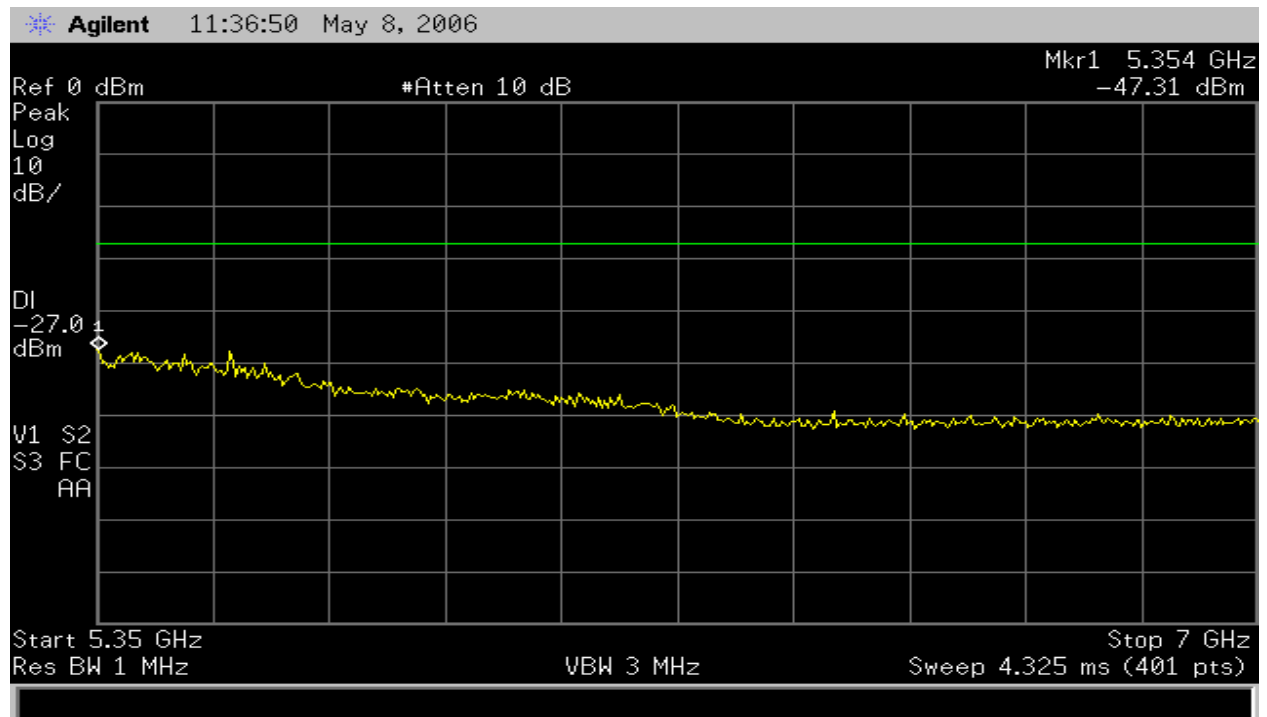

Figure 19 – 802.11a Conducted Spurious emissions worst case at 5.18GHz Transmit frequency

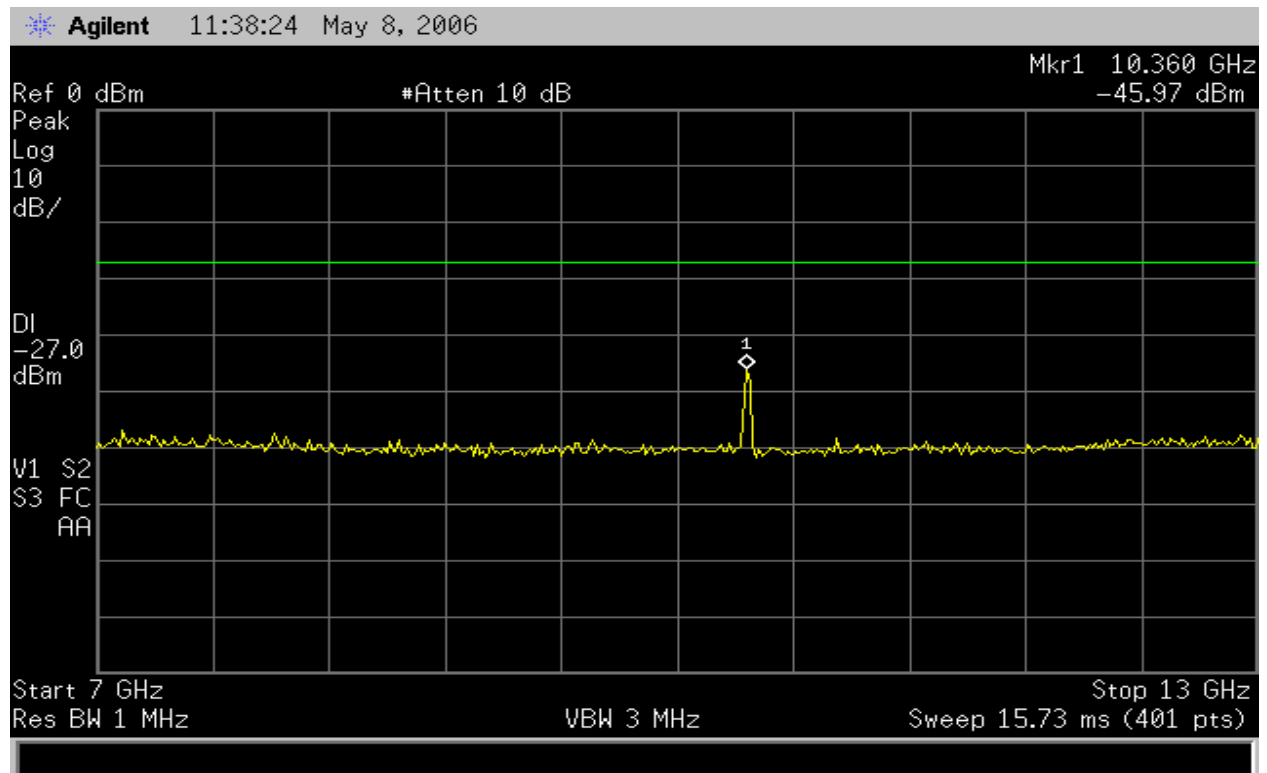

Figure 20 – 802.11a Conducted Spurious emissions worst case at 5.18GHz Transmit frequency

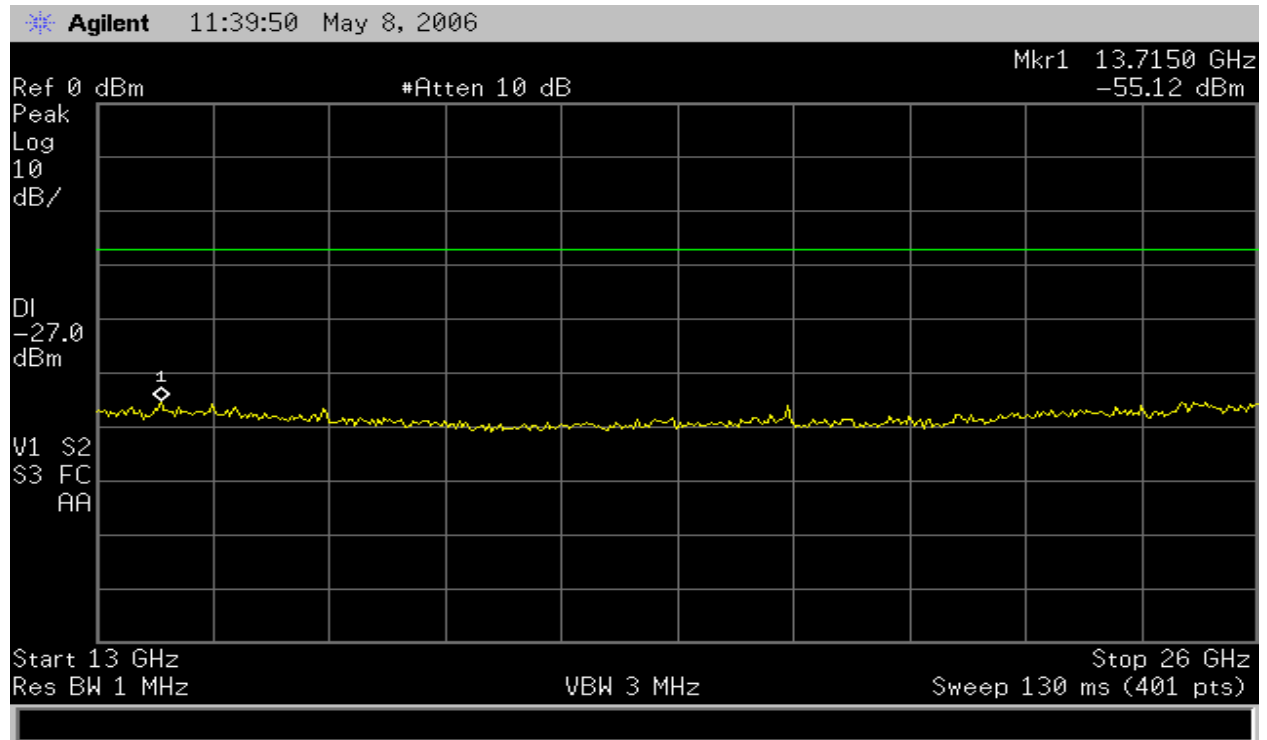
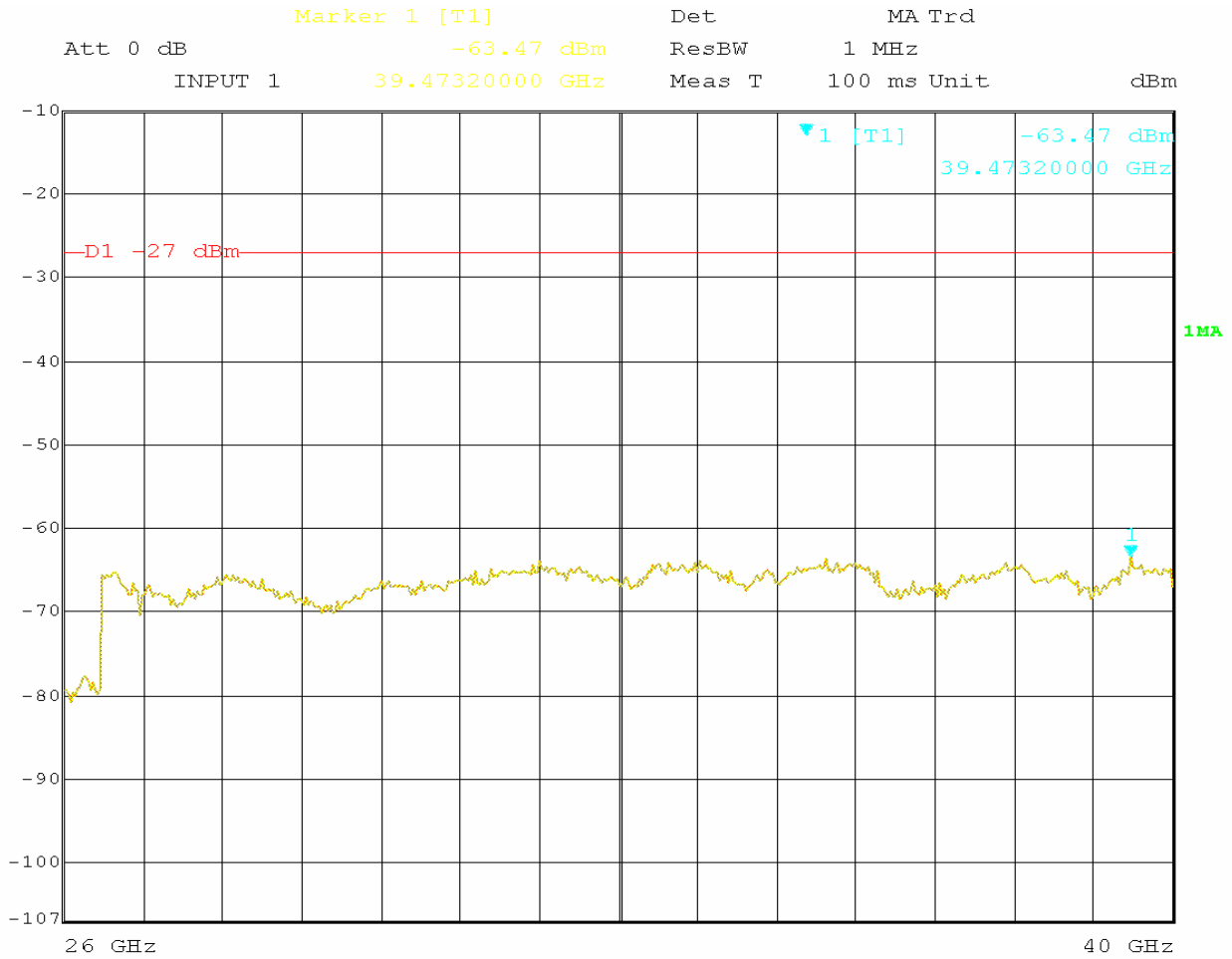

Figure 21 – 802.11a Conducted Spurious emissions worst case at 5.18GHz Transmit frequency



Date: 8.MAY.2006 13:26:18

Figure 22 – 802.11a Conducted Spurious emissions worst case at 5.18GHz Transmit frequency

4.8 Peak Power Spectral Density; FCC §15.407(e), RSS-210 §6.2.2(o)(b)

4.8.1 Test Procedure

For digitally modulated systems, the power spectral density conducted from the intentional radiator to the antenna shall not be greater than 8dBm. The transmitter output is connected to a spectrum analyzer, the maximum level in a 3kHz bandwidth is measured with the spectrum analyzer using RBW = 3 kHz, and VBW ≥ 3 kHz, sweep time = span / 3kHz with video averaging turned off. The peak Power Spectral Density is the highest level found across the emission in any 3 kHz band.

The Peak Power Spectral Density measurements were performed using the sample detector and power averaging mode. The procedures in FCC Public Notice # DA 02-2138; Aug 30, 2002 method #1 was used.

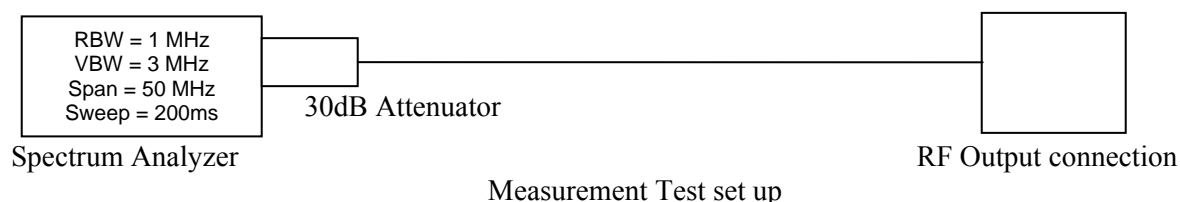

All Peak Power Spectral Density (PPSD) measurements are below the minimum limits set by parts 15.407(a)(1) at 4dBm, 15.407(a)(2) at 11dBm, and 15.407(a)(3).

Refer to TUV test report #30660840.002 for test results in the 5725-5825GHz band.

Table 8 – Table of PPSD Results

802.11a; 5.15 -5.25GHz Band, limit: 4dBm		
Center Frequency (GHz)	Peak Frequency (GHz)	Peak Power Spectral Density (dBm)
5.18 GHz	5.186	3.83
5.21 GHz	5.215	3.89
5.24 GHz	5.2397	3.99

802.11a; 5.25 -5.35GHz Band, limit: 11dBm		
Center Frequency (GHz)	Peak Frequency (GHz)	Peak Power Spectral Density (dBm)
5.28 GHz	5.285	6.24
5.30 GHz	5.298	6.11
5.32 GHz	5.317	4.32

Note: Emissions shown in red are highest emissions, see plots below

Refer to TUV test report #30660840.002 for test results in the 5725-5825GHz band.

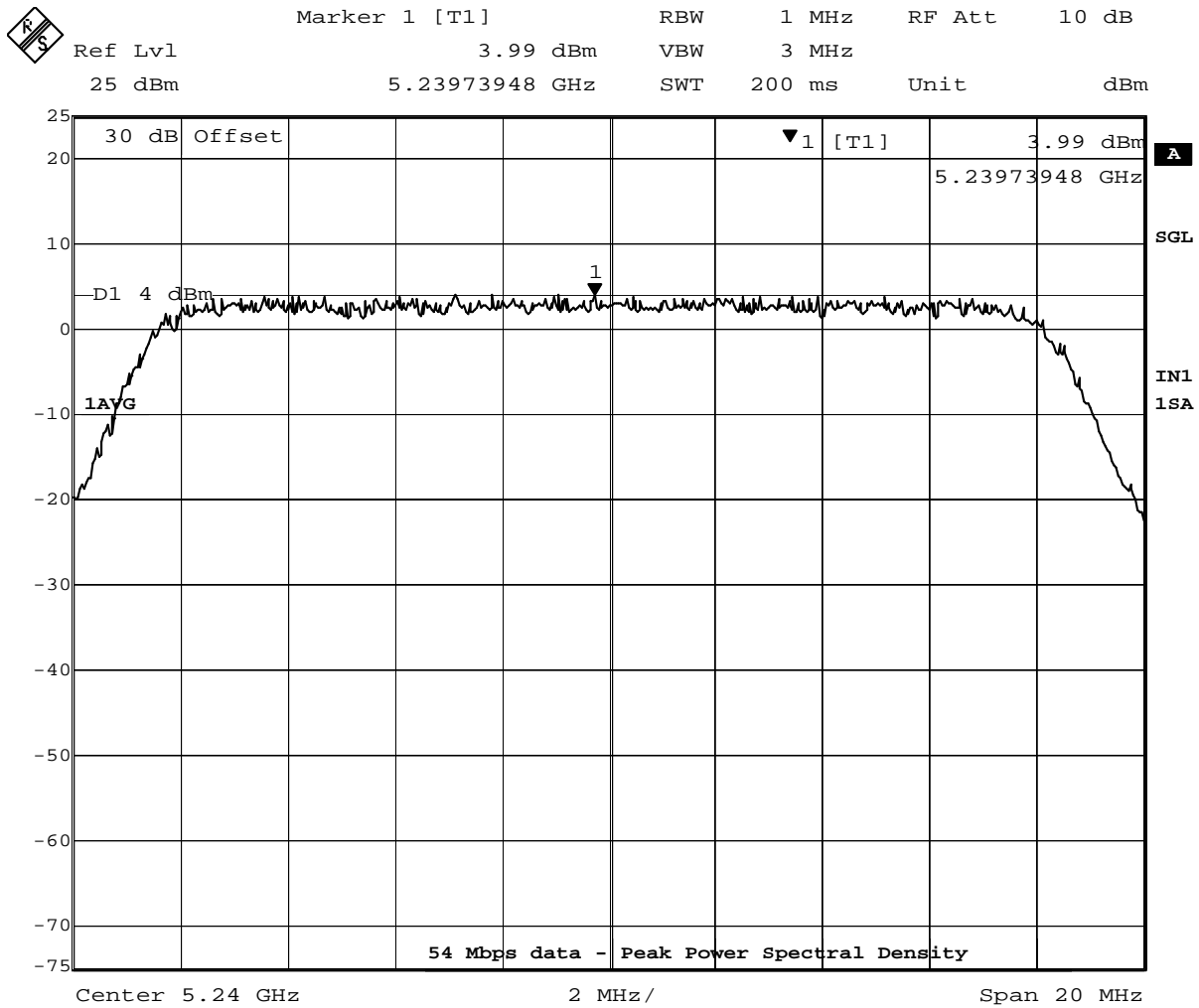

Date: 16.JUN.2006 09:24:06

Figure 23 – Peak Power Output for 802.11a - 5150 – 5250MHz

Note: plots for mid and high band are on file at TUV Rheinland – Raleigh office.

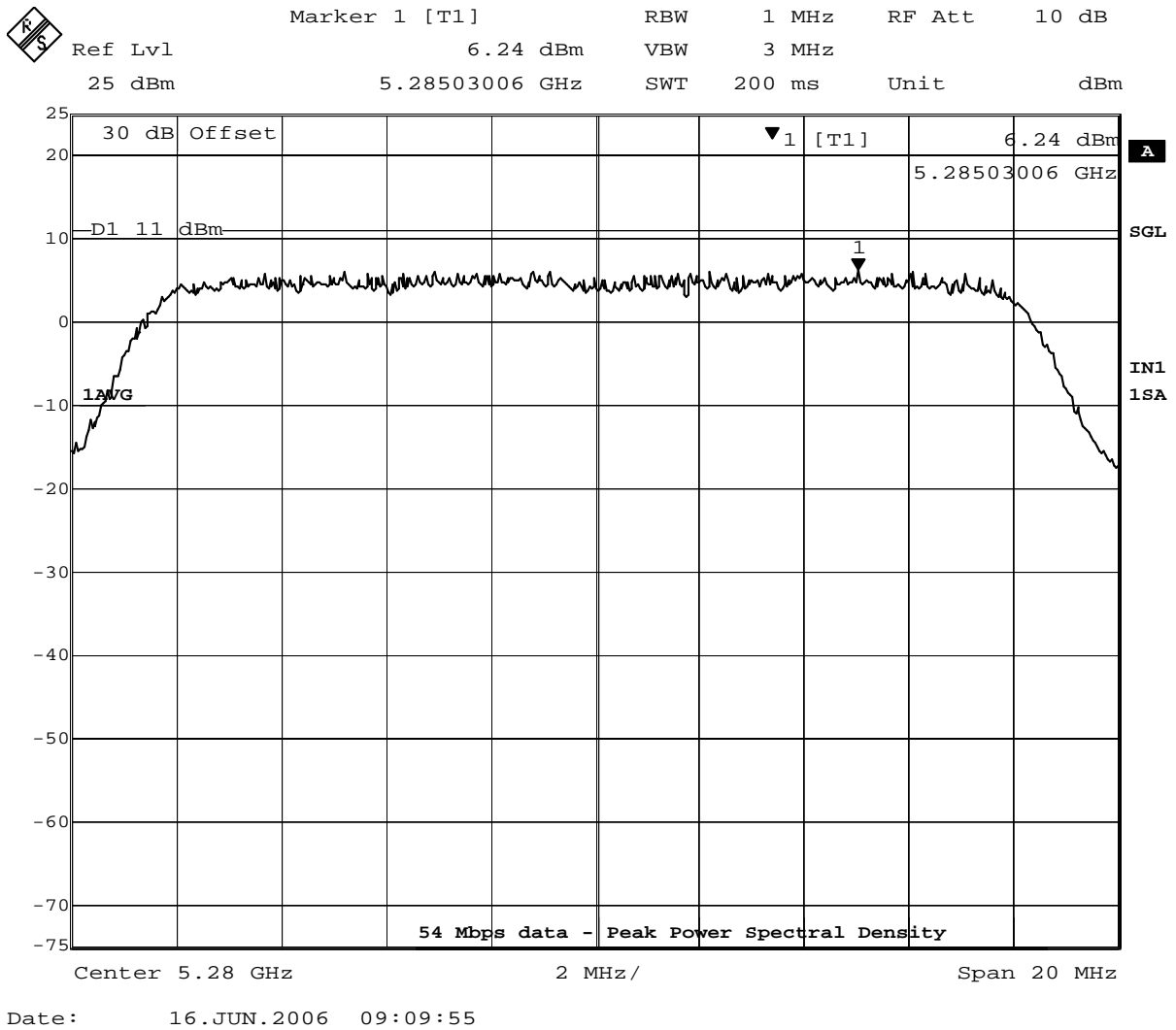

Figure 24 – Peak Power Output for 802.11a - 5250 – 5350MHz

Note: plots for low and mid band are on file at TUV Rheinland – Raleigh office.

4.9 Spurious Emissions; FCC §§15.205, 15.209, 15.407(b), RSS-210 §6.2.2(q1)

4.9.1 Test Procedure

4.9.1.1 Preliminary Test

A test program that controls instrumentation and data logging was used to automate the preliminary RF emission test procedure. The frequency range of interest was divided into sub-ranges to yield a frequency resolution of approximately 300 kHz and provide a reading at each frequency for each 6° of turntable rotation. For each frequency sub-range the turntable was rotated 360° while peak emission data was recorded and plotted over the frequency range of interest in horizontal and vertical antenna polarization's.

Preliminary emission profile testing was performed inside the anechoic chamber. The EUT was placed on a 1.0m x 1.5m non-conductive table 80cm above the floor. The EUT was positioned as shown in the setup photographs. The receiving antenna was placed at a distance of 3m at a fixed height of 1m. Measurement equipment was located outside of the chamber. A video camera was placed inside the chamber to view the EUT.

4.9.1.2 Final Test

For each frequency measured, the peak emission was maximized by manipulating the receiving antenna from 1 to 4 meters above the ground plane and placing it at the position that produced the maximum signal strength reading. The turntable was then rotated through 360° while observing the peak signal and placing the EUT at the position that produced maximum radiation. Final testing was performed on an NSA compliant test site. The EUT was placed on a 1.0m x 1.5m non-conductive table 80cm above the ground plane. The placement of EUT and cables were the same as for preliminary testing and is shown in the setup photographs.

The Quasi-Peak (QP) detector was used for frequencies at or less than 1000 MHz. Above 1000 MHz, the Average (Av) detector was used, and per part 15.35(b), the Peak limit is 20dB above average the average limit.

4.9.1.3 Deviations

There were no deviations from this test methodology.

4.9.2 Test Results

All harmonic emissions are more than 20dB below the fundamental frequencies

All emissions including emissions in all restricted bands, other than the fundamental frequencies and their harmonics, are below the 15.209 limits.

As originally tested, the EUT was found to be compliant to the requirements of the test standard(s).

4.9.2.1 Radiated Emissions outside the Frequency Band

In any 100kHz bandwidth outside the frequency band in which the spread spectrum or digitally modulated intentional radiator is operating, the radio frequency power that is produced by the intentional radiator shall be at least 20 dB below that in the 100 kHz bandwidth within the band that contains the highest level of desired power, based on radiated measurements.

SOP 1 Radiated Emissions

Tracking # 30660840.003 Page 1 of 10

EUT Name	WI-JACK DUO	Date	19 April 2006
EUT Model	OR-AP-DUOWJ	Temp / Hum in	75°F / 39%rh
EUT Serial	None	Temp / Hum out	n/a
Standard	FCC 47 CFR Part 15.407, RSS-210 Issue 6	Line AC / Freq.	N/A
Deg/sweep	12	RBW / VBW	120kHz / 300kHz
Dist/Ant Used	3m / 3110B-SAS516	Performed by	Mark Ryan
Configuration	Normal polling mode		

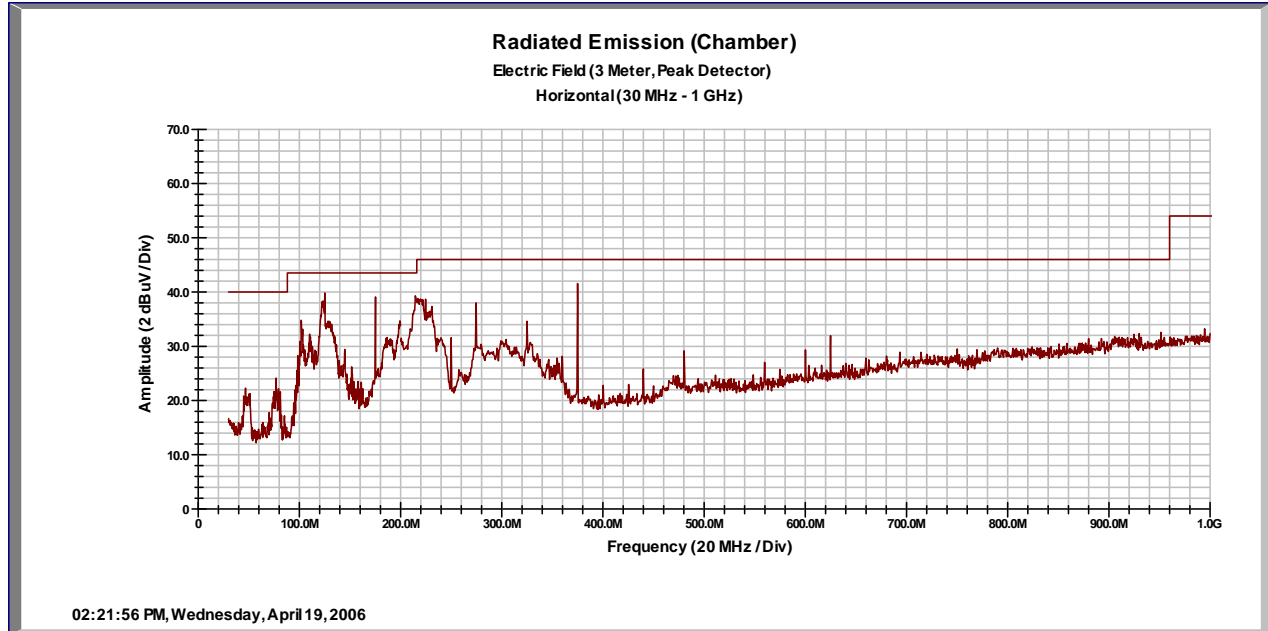

Emission Freq (MHz)	ANT Polar (H/V)	ANT Pos (m)	Table Pos (deg)	FIM Value (dBuV)	Amp Gain (dB)	Cable Loss (dB)	ANT Factor (dB/m)	E-Field Value (dBuV/m)	Spec Limit (dBuV/m)	Spec Margin (dB)
47.00	H	3.7	300	16.91	0.00	0.73	10.50	28.14	40.00	-11.86
125.00	H	1.5	297	28.88	0.00	1.21	11.90	41.99	43.50	-1.51
175.00	H	2	76	25.56	0.00	1.43	13.20	40.19	43.50	-3.31
219.44	H	1.4	354	29.51	0.00	1.63	11.20	42.34	46.00	-3.66
375.00	H	1	52	26.37	0.00	2.15	15.50	44.02	46.00	-1.98

Spec Margin = E-Field Value - Limit, E-Field Value = FIM Value - Amp Gain + Cable Loss + ANT Factor ± Uncertainty

Combined Standard Uncertainty $u_c(y) = \pm 1.6\text{dB}$ Expanded Uncertainty $U = ku_c(y)$ $k = 2$ for 95% confidence

Notes:

SOP 1 Radiated Emissions

Tracking # 30660840.003 Page 2 of 10

EUT Name	WI-JACK DUO	Date	19 April 2006
EUT Model	OR-AP-DUOWJ	Temp / Hum in	75°F / 39%rh
EUT Serial	None	Temp / Hum out	n/a
Standard	FCC 47 CFR Part 15.407, RSS-210 Issue 6	Line AC / Freq.	N/A
Deg/sweep	12	RBW / VBW	120kHz / 300kHz
Dist/Ant Used	3m / 3110B-SAS516	Performed by	Mark Ryan
Configuration	Normal polling mode		

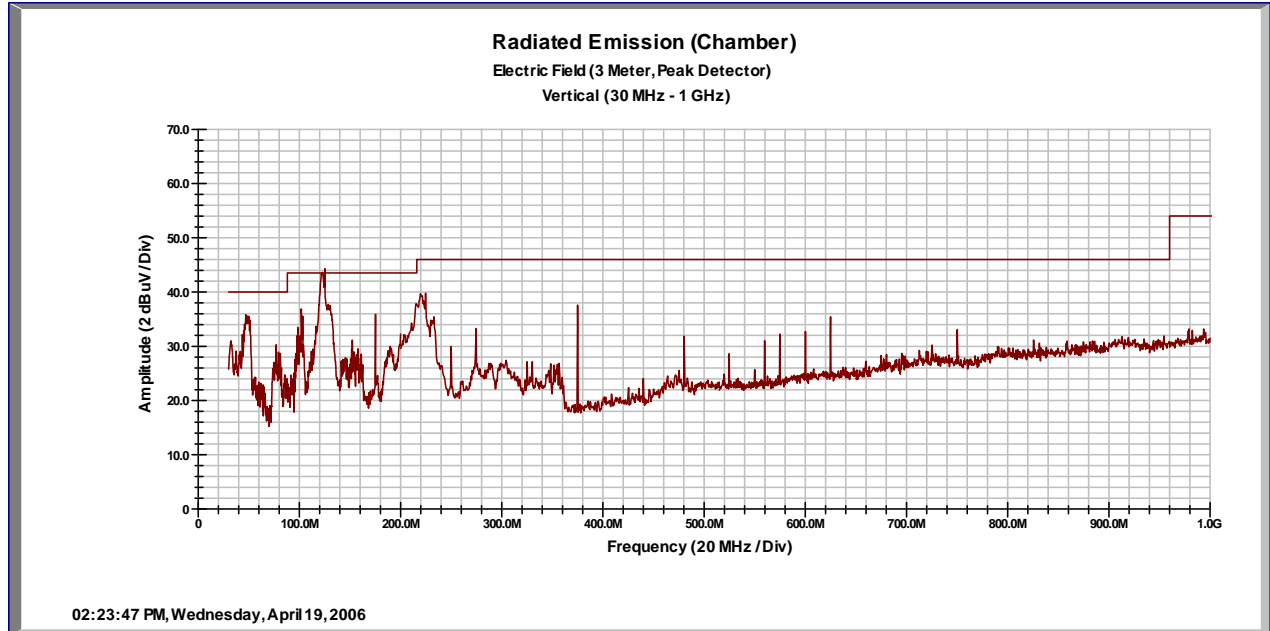

Emission Freq (MHz)	ANT Polar (H/V)	ANT Pos (m)	Table Pos (deg)	FIM Value (dBuV)	Amp Gain (dB)	Cable Loss (dB)	ANT Factor (dB/m)	E-Field Value (dBuV/m)	Spec Limit (dBuV/m)	Spec Margin (dB)
47.80	V	1.5	213	27.80	0.00	0.74	10.04	38.58	40.00	-1.42
125.00	V	1	344	28.24	0.00	1.21	12.20	41.65	43.50	-1.85
175.00	V	1	211	22.63	0.00	1.43	14.40	38.46	43.50	-5.04
231.92	V	1	240	23.65	0.00	1.66	11.59	36.91	46.00	-9.09
375.00	V	1	352	23.03	0.00	2.15	15.40	40.58	46.00	-5.42
625.00	V	1	97	15.18	0.00	2.81	18.80	36.79	46.00	-9.21

Spec Margin = E-Field Value - Limit, E-Field Value = FIM Value - Amp Gain + Cable Loss + ANT Factor ± Uncertainty

Combined Standard Uncertainty $u_c(y) = \pm 1.6\text{dB}$ Expanded Uncertainty $U = ku_c(y)$ $k = 2$ for 95% confidence

Notes:

SOP 1 Radiated Emissions

Tracking # 30660840.003 Page 3 of 10

EUT Name	WI-JACK DUO	Date	19 April 2006
EUT Model	OR-AP-DUOWJ	Temp / Hum in	75°F / 39%rh
EUT Serial	None	Temp / Hum out	n/a
Standard	FCC 47 CFR Part 15.407, RSS-210 Issue 6	Line AC / Freq.	N/A
Deg/sweep	6	RBW / VBW	1MHz / 3MHz
Dist/Ant Used	3m / 3115_2236	Performed by	Mark Ryan
Configuration	Normal polling mode		

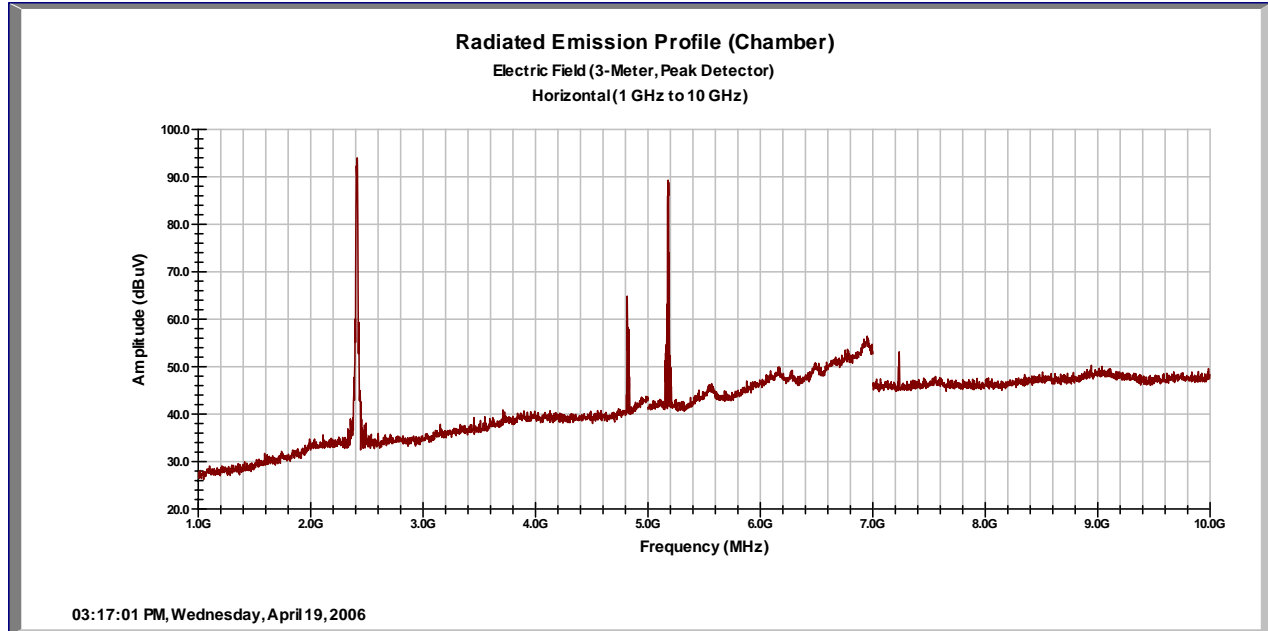

Emission Freq (MHz)	ANT Polar (H/V)	ANT Pos (m)	Table Pos (deg)	FIM Av Value (dBuV)	Amp Gain (dB)	Cable Loss (dB)	ANT Factor (dB/m)	E-Field Value (dBuV/m)	Spec Limit (dBuV/m)	Spec Margin (dB)
4807.60	H	1.5	80	28.70	35.22	10.86	33.12	37.45	54.00	-16.55
7238.80	H	1.5	81	24.73	35.04	16.00	36.20	41.89	54.00	-12.11

Spec Margin = E-Field Value - Limit, E-Field Value = FIM Value - Amp Gain + Cable Loss + ANT Factor ± Uncertainty

Combined Standard Uncertainty $u_c(y) = \pm 1.6\text{dB}$ Expanded Uncertainty $U = k u_c(y)$ $k = 2$ for 95% confidence

Notes: The spike just above 5GHz is the 802.11a transmitter; refer to report # 30660840.003 for details.

SOP 1 Radiated Emissions

Tracking # 30660840.003 Page 4 of 10

EUT Name	WI-JACK DUO	Date	19 April 2006
EUT Model	OR-AP-DUOWJ	Temp / Hum in	75°F / 39%rh
EUT Serial	None	Temp / Hum out	n/a
Standard	FCC 47 CFR Part 15.407, RSS-210 Issue 6	Line AC / Freq.	N/A
Deg/sweep	6	RBW / VBW	1MHz / 3MHz
Dist/Ant Used	3m / 3115_2236	Performed by	Mark Ryan
Configuration	Normal polling mode		

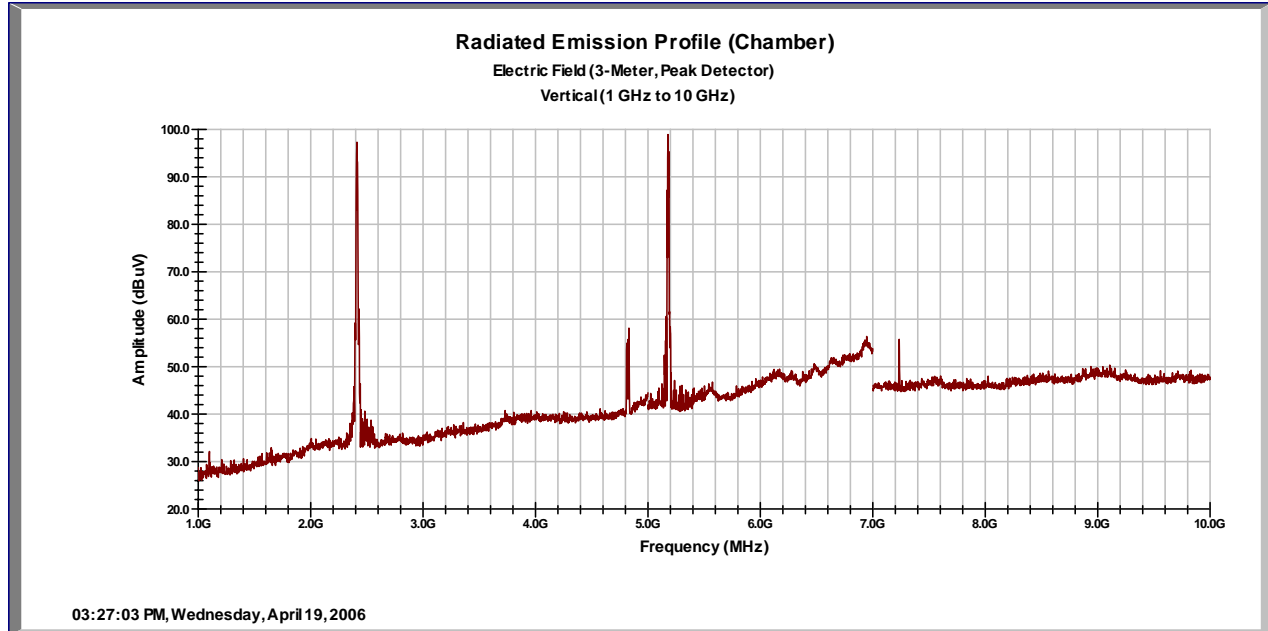

Emission Freq (MHz)	ANT Polar (H/V)	ANT Pos (m)	Table Pos (deg)	FIM Av Value (dBuV)	Amp Gain (dB)	Cable Loss (dB)	ANT Factor (dB/m)	E-Field Value (dBuV/m)	Spec Limit (dBuV/m)	Spec Margin (dB)
4807.60	V	1.5	81	17.48	35.22	10.86	33.15	26.27	54.00	-27.73
7238.80	V	1.6	95	24.86	35.04	16.00	36.16	41.97	54.00	-12.03

Spec Margin = E-Field Value - Limit, E-Field Value = FIM Value - Amp Gain + Cable Loss + ANT Factor ± Uncertainty

Combined Standard Uncertainty $u_c(y) = \pm 1.6\text{dB}$ Expanded Uncertainty $U = k u_c(y)$ $k = 2$ for 95% confidence

Notes: The spike just above 2GHz is the 802.11b/g transmitter; refer to report #01 30660840.002 for details.

SOP 1 Radiated Emissions

Tracking # 30660840.003 Page 5 of 10

EUT Name	WI-JACK DUO	Date	19 April 2006
EUT Model	OR-AP-DUOWJ	Temp / Hum in	75°F / 39%rh
EUT Serial	None	Temp / Hum out	n/a
Standard	FCC 47 CFR Part 15.407, RSS-210 Issue 6	Line AC / Freq.	N/A
Deg/sweep	6	RBW / VBW	1MHz / 3MHz
Dist/Ant Used	3m / 3115_2236	Performed by	Mark Ryan
Configuration	Normal polling mode		

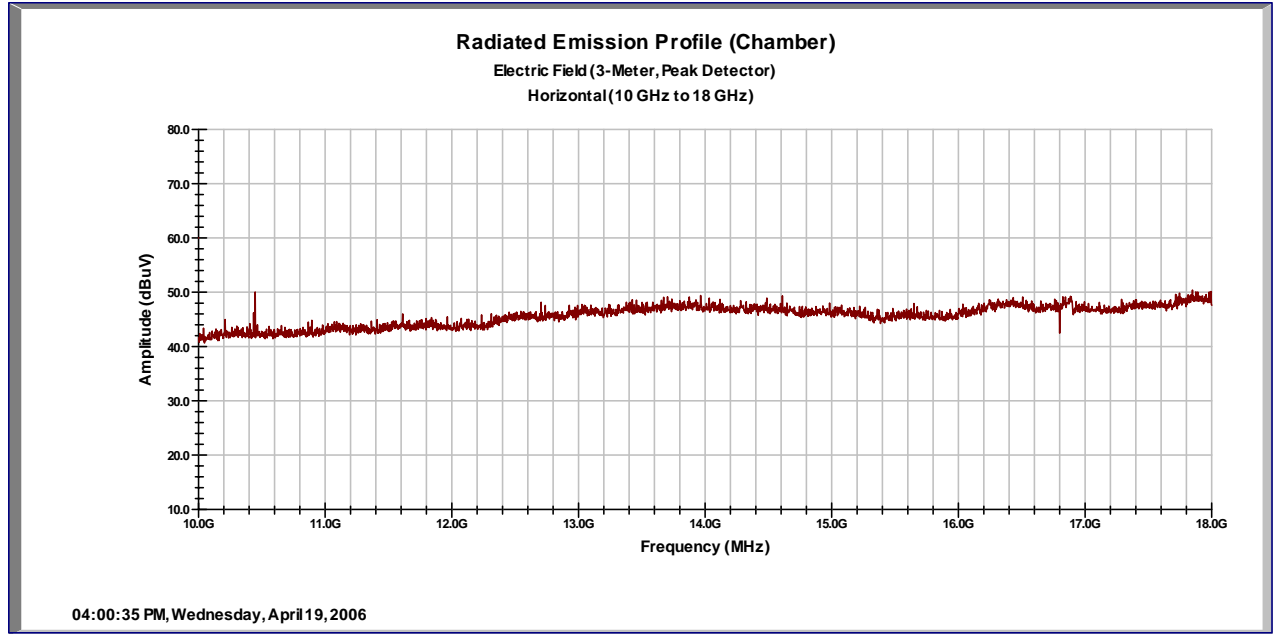

Emission Freq (MHz)	ANT Polar (H/V)	ANT Pos (m)	Table Pos (deg)	FIM Av Value (dBuV)	Amp Gain (dB)	Cable Loss (dB)	ANT Factor (dB/m)	E-Field Value (dBuV/m)	Spec Limit (dBuV/m)	Spec Margin (dB)
1034.40	V	1.2	151	19.44	36.70	4.67	24.10	11.50	54.00	-42.50

Spec Margin = E-Field Value - Limit, E-Field Value = FIM Value - Amp Gain + Cable Loss + ANT Factor ± Uncertainty

Combined Standard Uncertainty $u_c(y) = \pm 1.6\text{dB}$ Expanded Uncertainty $U = k u_c(y)$ $k = 2$ for 95% confidence

Notes: 2nd harmonic of 5GHz

SOP 1 Radiated Emissions

Tracking # 30660840.003 Page 6 of 10

EUT Name	WI-JACK DUO	Date	19 April 2006
EUT Model	OR-AP-DUOWJ	Temp / Hum in	75°F / 39%rh
EUT Serial	None	Temp / Hum out	n/a
Standard	FCC 47 CFR Part 15.407, RSS-210 Issue 6	Line AC / Freq.	N/A
Deg/sweep	6	RBW / VBW	1MHz / 3MHz
Dist/Ant Used	3m / 3115_2236	Performed by	Mark Ryan
Configuration	Normal polling mode		

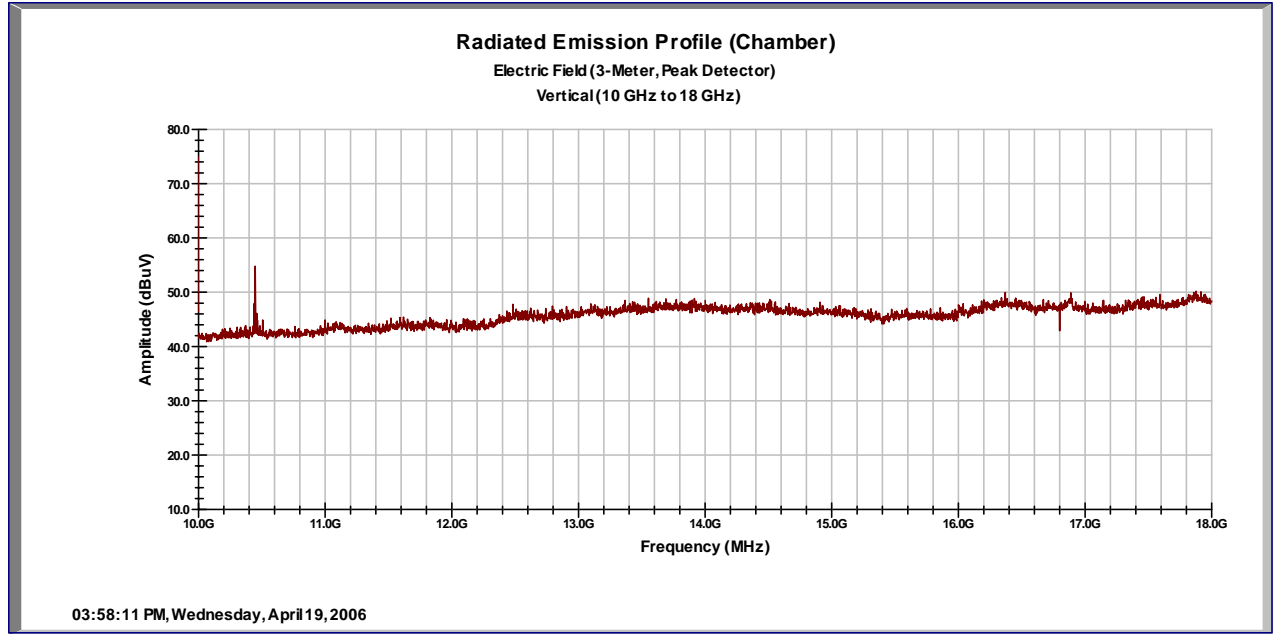

Emission Freq (MHz)	ANT Polar (H/V)	ANT Pos (m)	Table Pos (deg)	FIM Av Value (dBuV)	Amp Gain (dB)	Cable Loss (dB)	ANT Factor (dB/m)	E-Field Value (dBuV/m)	Spec Limit (dBuV/m)	Spec Margin (dB)
10356.40	V	1.1	35	20.18	35.17	16.98	38.37	40.36	54.00	-13.64

Spec Margin = E-Field Value - Limit, E-Field Value = FIM Value - Amp Gain + Cable Loss + ANT Factor ± Uncertainty

Combined Standard Uncertainty $u_c(y) = \pm 1.6\text{dB}$ Expanded Uncertainty $U = ku_c(y)$ $k = 2$ for 95% confidence

Notes: Emission is 2nd harmonic of 5GHz see report 30660840.003

SOP 1 Radiated Emissions

Tracking # 30660840.003 Page 7 of 10

EUT Name	WI-JACK DUO	Date	19 April 2006
EUT Model	OR-AP-DUOWJ	Temp / Hum in	75°F / 39%rh
EUT Serial	None	Temp / Hum out	n/a
Standard	FCC 47 CFR Part 15.407, RSS-210 Issue 6	Line AC / Freq.	N/A
Deg/sweep	6	RBW / VBW	1MHz / 3MHz
Dist/Ant Used	1m / MA86552 Horn	Performed by	Mark Ryan
Configuration	Normal polling mode		

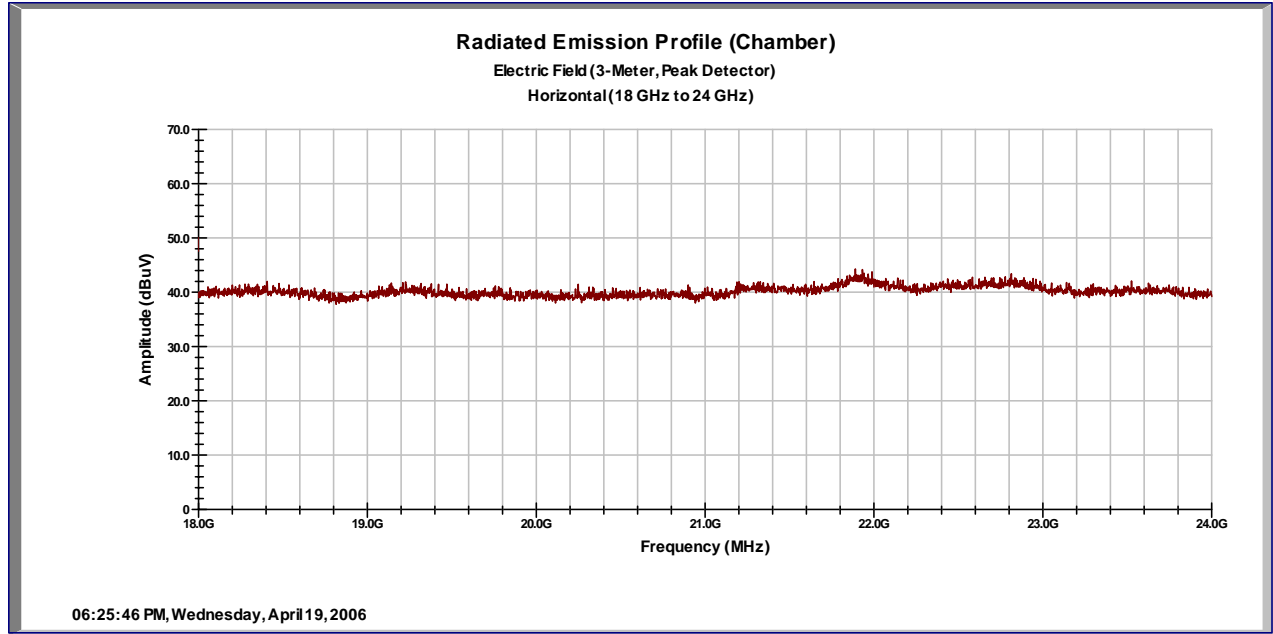

Emission Freq (MHz)	ANT Polar (H/V)	ANT Pos (m)	Table Pos (deg)	FIM Value (dBuV)	Amp Gain (dB)	Cable Loss (dB)	ANT Factor (dB/m)	E-Field Value (dBuV/m)	Spec Limit (dBuV/m)	Spec Margin (dB)

Spec Margin = E-Field Value - Limit, E-Field Value = FIM Value - Amp Gain + Cable Loss + ANT Factor ± Uncertainty

Combined Standard Uncertainty $u_c(y) = \pm 1.6\text{dB}$ Expanded Uncertainty $U = ku_c(y)$ $k = 2$ for 95% confidence

Notes: Any Signals were indistinguishable from noise floor.

SOP 1 Radiated Emissions

Tracking # 30660840.003 Page 8 of 10

EUT Name	WI-JACK DUO	Date	19 April 2006
EUT Model	OR-AP-DUOWJ	Temp / Hum in	75°F / 39%rh
EUT Serial	None	Temp / Hum out	n/a
Standard	FCC 47 CFR Part 15.407, RSS-210 Issue 6	Line AC / Freq.	N/A
Deg/sweep	6	RBW / VBW	1MHz / 3MHz
Dist/Ant Used	1m / MA86552 Horn	Performed by	Mark Ryan
Configuration	Normal polling mode		

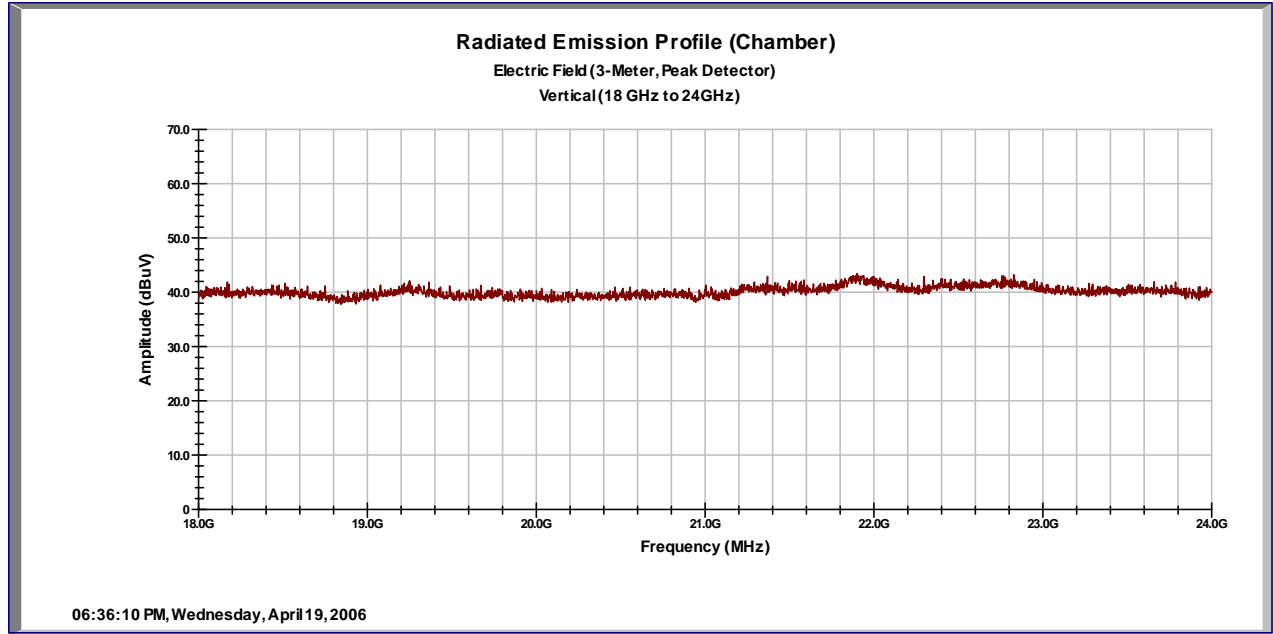

Emission Freq (MHz)	ANT Polar (H/V)	ANT Pos (m)	Table Pos (deg)	FIM Value (dBuV)	Amp Gain (dB)	Cable Loss (dB)	ANT Factor (dB/m)	E-Field Value (dBuV/m)	Spec Limit (dBuV/m)	Spec Margin (dB)

Spec Margin = E-Field Value - Limit, E-Field Value = FIM Value - Amp Gain + Cable Loss + ANT Factor ± Uncertainty

Combined Standard Uncertainty $u_c(y) = \pm 1.6\text{dB}$ Expanded Uncertainty $U = ku_c(y)$ $k = 2$ for 95% confidence

Notes: Any Signals were indistinguishable from noise floor.

SOP 1 Radiated Emissions

Tracking # 30660840.003 Page 9 of 10

EUT Name	WI-JACK DUO	Date	19 April 2006
EUT Model	OR-AP-DUOWJ	Temp / Hum in	75°F / 39%rh
EUT Serial	None	Temp / Hum out	n/a
Standard	FCC 47 CFR Part 15.407, RSS-210 Issue 6	Line AC / Freq.	N/A
Deg/sweep	6	RBW / VBW	1MHz / 3MHz
Dist/Ant Used	1m / 28-0442-6 Horn	Performed by	Mark Ryan
Configuration	Normal polling mode		

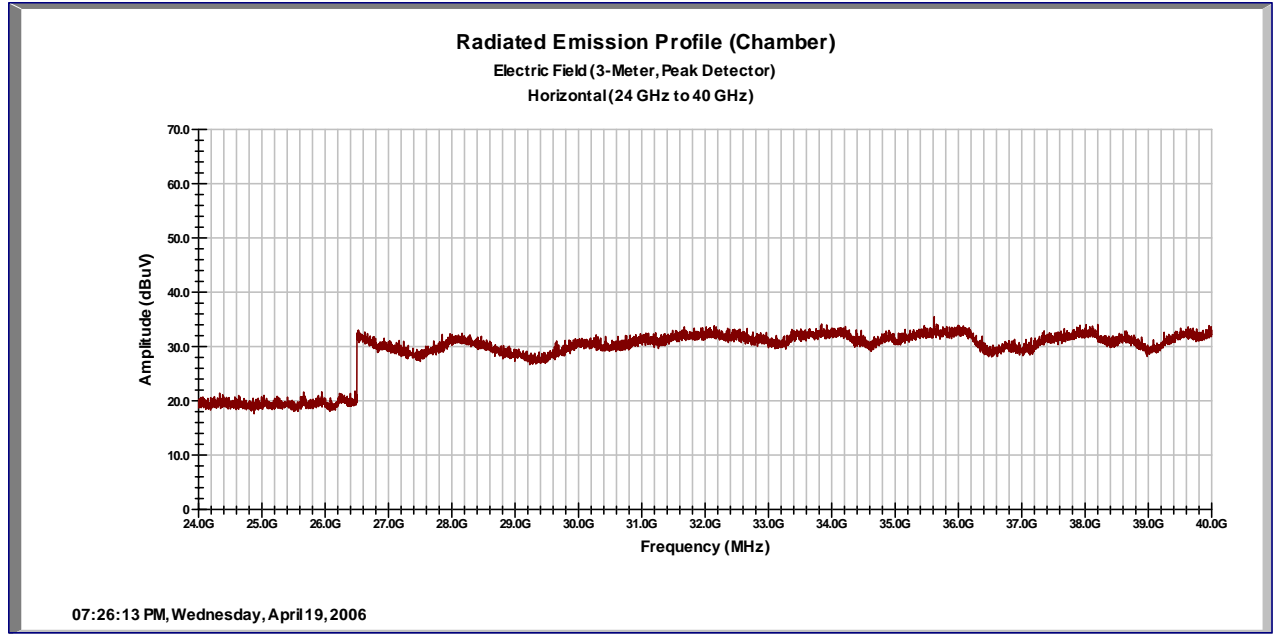

Emission Freq (MHz)	ANT Polar (H/V)	ANT Pos (m)	Table Pos (deg)	FIM Value (dBUV)	Amp Gain (dB)	Cable Loss (dB)	ANT Factor (dB/m)	E-Field Value (dBUV/m)	Spec Limit (dBUV/m)	Spec Margin (dB)

Spec Margin = E-Field Value - Limit, E-Field Value = FIM Value - Amp Gain + Cable Loss + ANT Factor ± Uncertainty

Combined Standard Uncertainty $u_c(y) = \pm 1.6\text{dB}$ Expanded Uncertainty $U = k u_c(y)$ $k = 2$ for 95% confidence

Notes: No correction factors shown. All emissions are indistinguishable from background noise.

SOP 1 Radiated Emissions

Tracking # 30660840.003 Page 10 of 10

EUT Name	WI-JACK DUO	Date	19 April 2006
EUT Model	OR-AP-DUOWJ	Temp / Hum in	75°F / 39%rh
EUT Serial	None	Temp / Hum out	n/a
Standard	FCC 47 CFR Part 15.407, RSS-210 Issue 6	Line AC / Freq.	N/A
Deg/sweep	6	RBW / VBW	1MHz / 3MHz
Dist/Ant Used	1m / 28-0442-6 Horn	Performed by	Mark Ryan
Configuration	Normal polling mode		

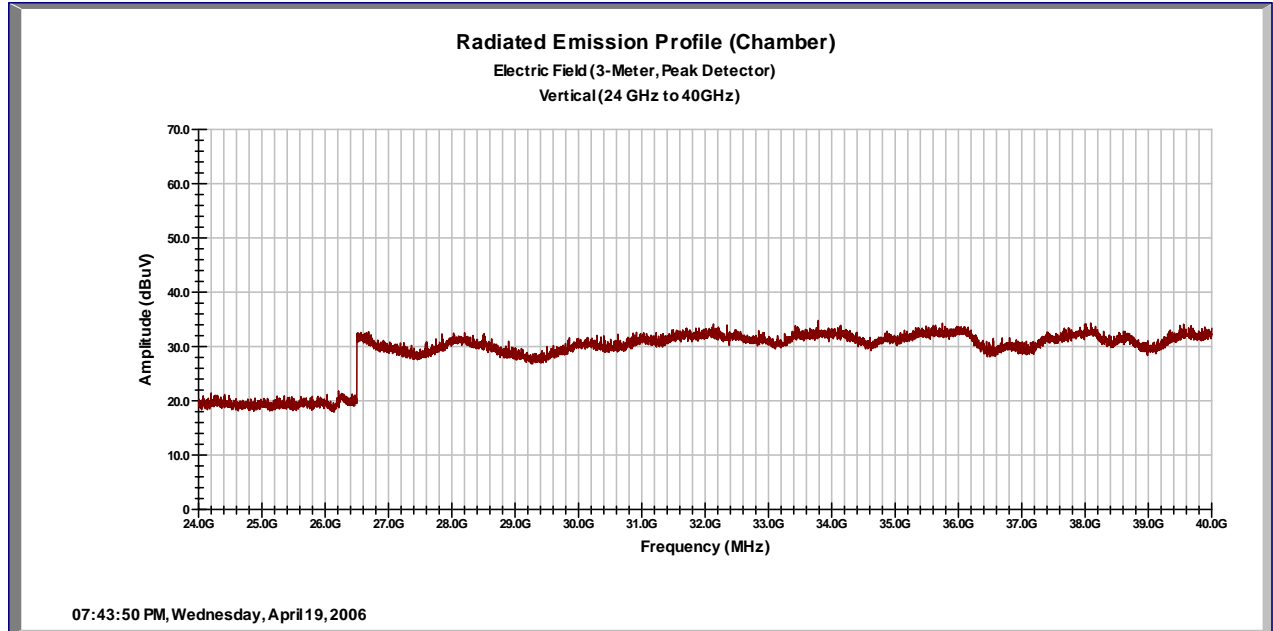

Emission Freq (MHz)	ANT Polar (H/V)	ANT Pos (m)	Table Pos (deg)	FIM Value (dBUV)	Amp Gain (dB)	Cable Loss (dB)	ANT Factor (dB/m)	E-Field Value (dBUV/m)	Spec Limit (dBUV/m)	Spec Margin (dB)

Spec Margin = E-Field Value - Limit, E-Field Value = FIM Value - Amp Gain + Cable Loss + ANT Factor ± Uncertainty

Combined Standard Uncertainty $u_c(y) = \pm 1.6\text{dB}$ Expanded Uncertainty $U = k u_c(y)$ $k = 2$ for 95% confidence

Notes: No correction factor shown. All emissions are indistinguishable from background noise.

4.9.3 Sample Calculation

The field strength is calculated by subtracting the Amplifier Gain and adding the Cable Loss and Antenna Correction Factor to the measured reading. The basic equation is as follows:

$$\text{Field Strength (dB}\mu\text{V/m)} = \text{FIM} - \text{AMP} + \text{CBL} + \text{ACF}$$

Where: FIM = Field Intensity Meter (dB μ V)
AMP = Amplifier Gain (dB)
CBL = Cable Loss (dB)
ACF = Antenna Correction Factor (dB/m)

$$\mu\text{V/m} = 10^{\frac{\text{dB}\mu\text{V} / \text{m}}{20}}$$

4.10 AC Conducted Emissions; FCC §15.207(b), RSS-210 §§6.6(b),7.4

This test measures the levels emanating from the EUT through the PoE to the Power line, thus evaluating the potential for the EUT to cause radio frequency interference to other electronic devices. The EUT was set to transmit mid-band with 802.11a modulation.

4.10.1 Test Methodology

A test program that controls instrumentation and data logging was used to automate the AC Power Line Conducted emission test procedure. The frequency range of interest was divided into sub-ranges such as to yield a frequency resolution of 9 kHz. For each frequency sub-range, each phase and neutral of the AC power line were measured with respect to ground. Measurements were performed using a set of 50μH / 50Ω LISNs.

Testing is either performed in the anechoic chamber or on PLC Site 2. The setup photographs clearly identify which site was used. The vertical ground plane used in the anechoic chamber is a 2m x 2m wooden frame that is covered with ¼ inch hardware cloth and is bonded to the horizontal ground plane.

In the case of tabletop equipment, the EUT is placed on a 1.0m x 1.5m non-conductive table 80cm above the ground plane and 40cm from a vertical ground reference plane. The rear of the EUT was positioned flush with the backside of the table and directly over the LISNs. The power and I/O cables were routed over the edge of the table and bundled approximately 40cm from the ground plane. Support equipment was powered from a separate LISN. Floor-standing equipment is placed directly on the ground plane.

4.10.1.1 Deviations

There were no deviations from this test methodology.

4.10.2 Test Results

Section 4.10.2.1 lists the final measurement data under the worst case operating modes, configurations, and/or cable positions.

As originally tested, the EUT was found to be compliant to the requirements of the test standard(s).

Plots of the EUT's AC Line Conducted emissions are contained in the following sections. The plots show peak and/or average emissions and the corresponding peak and/or average limits. If the peak emissions are below the average limit, then the EUT is considered to pass and no average measurements are made. If the peak emissions are below the quasi-peak limit and the average emissions are below the average limit, then the EUT is considered to pass and no further measurements are made. Otherwise, individual frequencies are measured and compared to the corresponding limit for the detector used (quasi-peak or average).

4.10.2.1 Final Data

The data recorded in this section contains the final results under the worst-case conditions and with any modifications or special accessories implemented as the manufacturer intends.

SOP 2 Conducted Emissions

Tracking # 30660840.003 Page 1 of 2

EUT Name	WI-JACK DUO	Date	11 May 2006
EUT Model	OR-AP-DUOWJ	Temperature	72°F
EUT Serial	None	Humidity	54%rh
Standard	FCC 47 CFR Part 15.407, RSS-210 Issue 6	Line AC /Freq	120VAC / 60Hz
LISNs Used	1	Performed by	Mark Ryan

Configuration 802.11a - transmitting mid-band

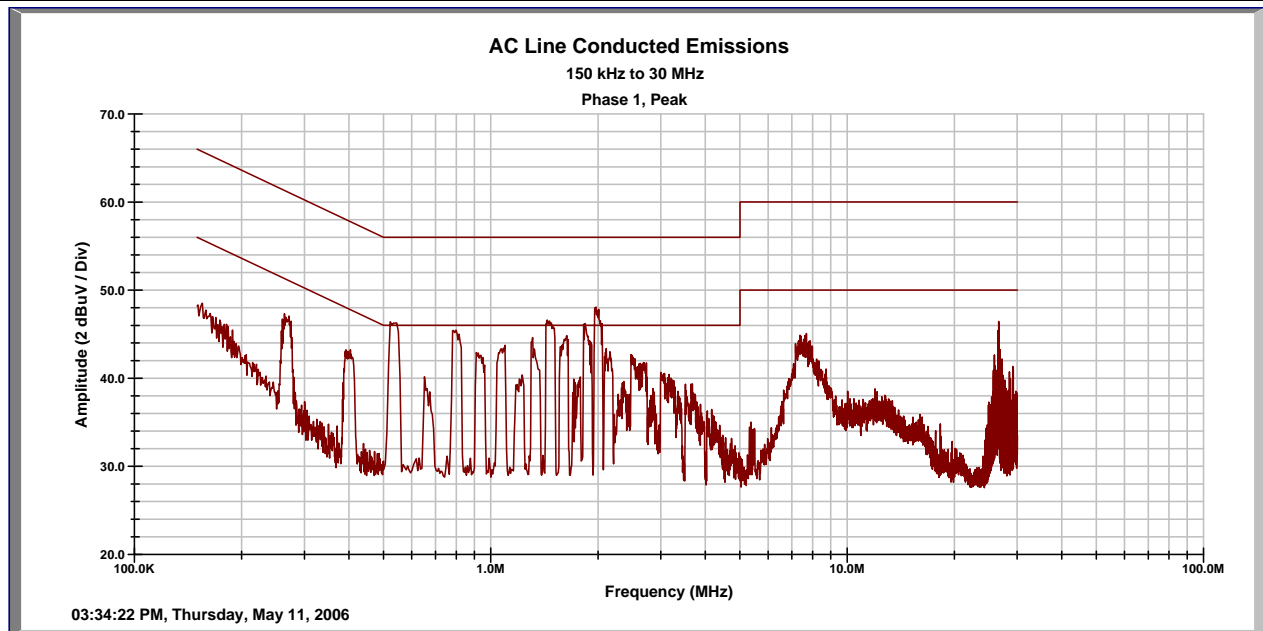

Emission Freq (MHz)	Line ID (1,2,3,N)	FIM Quasi (dBuV)	FIM Ave (dBuV)	Cable Loss (dB)	LISN + T Limiter (dB)	Quasi Limit (dBuV)	Ave Limit (dBuV)	Quasi Spec Margin (dB)	Ave Spec Margin (dB)
0.62	1	33.98	26.06	0.01	10.03	56.00	46.00	-11.98	-9.90
0.54	1	34.51	21.46	0.01	10.03	56.00	46.00	-11.45	-14.50
1.43	1	33.12	18.63	0.04	10.05	56.00	46.00	-12.79	-17.28
1.82	1	32.45	11.03	0.04	10.06	56.00	46.00	-13.45	-24.87
2.00	1	33.74	10.90	0.04	10.06	56.00	46.00	-12.16	-25.00
7.41	1	28.52	13.96	0.09	10.29	60.00	50.00	-21.10	-25.66
26.49	1	35.53	31.11	0.19	10.49	60.00	50.00	-13.79	-8.21

Quasi Spec Margin = Quasi FIM + Cable Loss + LISN CF - Quasi Limit ± Uncertainty

Ave Spec Margin = Ave FIM + Cable Loss + LISN CF - Ave Limit ± Uncertainty

Combined Standard Uncertainty $u_c(y) = \pm 1.2\text{dB}$ Expanded Uncertainty $U = k u_c(y)$ $k = 2$ for 95% confidence

Notes:

SOP 2 Conducted Emissions

Tracking # 30660840.003 Page 2 of 2

EUT Name	WI-JACK DUO	Date	11 May 2006
EUT Model	OR-AP-DUOWJ	Temperature	72°F
EUT Serial	None	Humidity	54%rh
Standard	FCC 47 CFR Part 15.407, RSS-210 Issue 6	Line AC /Freq	120VAC / 60Hz
LISNs Used	2	Performed by	Mark Ryan

Configuration 802.11a - transmitting mid-band

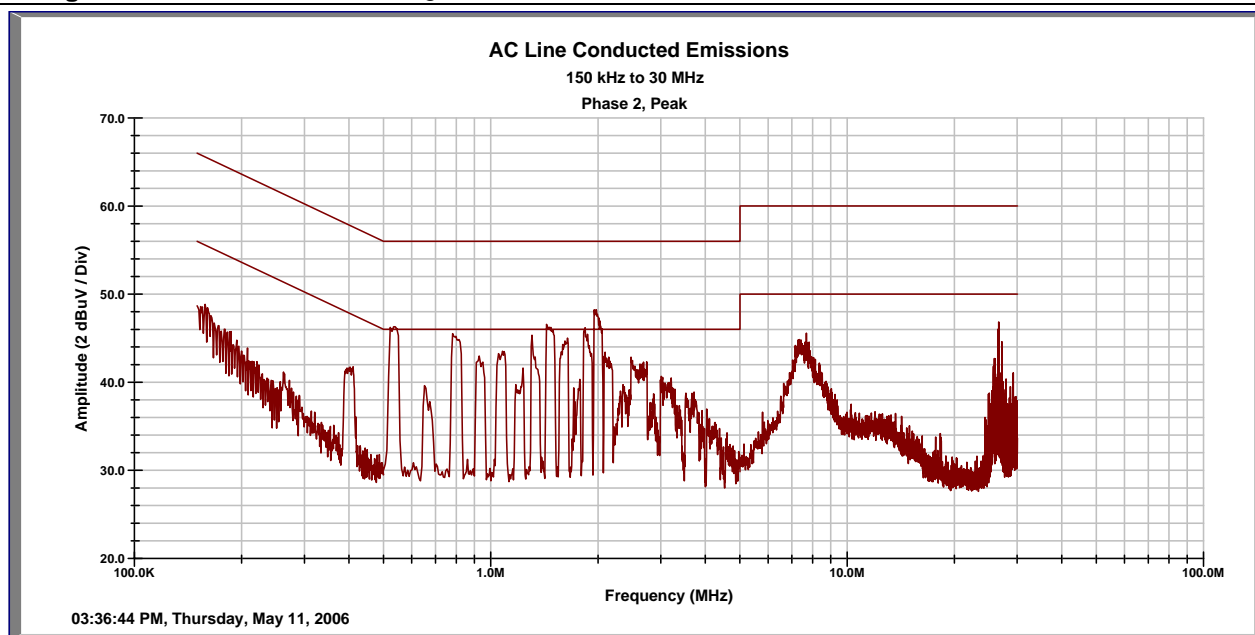

Emission Freq (MHz)	Line ID (1,2,3,N)	FIM Quasi (dBuV)	FIM Ave (dBuV)	Cable Loss (dB)	LISN + T Limiter (dB)	Quasi Limit (dBuV)	Ave Limit (dBuV)	Quasi Spec Margin (dB)	Ave Spec Margin (dB)
0.39	2	28.99	21.15	0.01	10.10	58.06	48.06	-18.97	-16.81
0.51	2	34.37	23.96	0.02	10.08	56.00	46.00	-11.53	-11.94
1.44	2	32.93	17.76	0.04	10.05	56.00	46.00	-12.98	-18.15
1.82	2	32.41	10.83	0.04	10.06	56.00	46.00	-13.49	-25.07
2.00	2	34.44	11.65	0.04	10.06	56.00	46.00	-11.46	-24.25
7.41	2	28.64	14.13	0.09	10.29	60.00	50.00	-20.98	-25.49
26.49	2	35.85	31.55	0.19	10.49	60.00	50.00	-13.47	-7.77

Quasi Spec Margin = Quasi FIM + Cable Loss + LISN CF - Quasi Limit ± Uncertainty

Ave Spec Margin = Ave FIM + Cable Loss + LISN CF - Ave Limit ± Uncertainty

Combined Standard Uncertainty $u_c(y) = \pm 1.2\text{dB}$ Expanded Uncertainty $U = k u_c(y)$ $k = 2$ for 95% confidence

Notes:

4.10.3 Sample Calculation

The signal strength is calculated by adding the LISN Correction Factor and Cable Loss to the measured reading. The basic equation is as follows:

$$\text{Field Strength (dB}\mu\text{V/m)} = \text{FIM} + \text{CBL} + \text{LCF}$$

Where: FIM = Field Intensity Meter (dB μ V)
 CBL = Cable Loss (dB)
 LCF = LISN Loss (dB)

$$\mu\text{V/m} = 10^{\frac{\text{dB}\mu\text{V} / \text{m}}{20}}$$

5 Test Equipment Use List

Equipment	Manufacturer	Model #	Serial/Inst #	Last Cal dd/mm/yy	Next Cal dd/mm/yy
SOP 1 - Radiated Emissions (5 Meter Chamber)					
Ant. Biconical	EMCO	3110B	3367	24-Feb-05	24-Feb-06
Ant. Log Periodic	AH Systems	SAS-516	133	7- Feb-05	7- Feb-06
Antenna Horn 1-18GHz	EMCO	3115	2236	29-Dec-05	29-Dec-06
Antenna Horn 18-26.5GHz	AR2	MA86552	8426	8-Aug-05	8-Aug-06
Antenna Horn 26.5 - 40GHz	ATI, Inc	28-442-6/CAL	G047702-01	14-Feb-06	14-Feb-07
Cable, Coax	Andrew	FSJ1-50A	03	15-Jan-06	15-Jan-07
Cable, Coax	Andrew	FSJ1-50A	30	15-Jan-06	15-Jan-07
Cable, Coax	Andrew	FSJ1-50A	45	15-Jan-06	15-Jan-07
Receiver, EMI	Rohde & Schwarz	ESIB40	100043	22-Dec-05	22-Dec-06
Spectrum Analyzer	Agilent Tec.	E7405A	US39440157	3-Aug-05	3-Aug-06
Spectrum Analyzer	Agilent Tec.	E7405A	US39440161	27-Feb-06	27-Feb-07

General Laboratory Equipment					
Meter, Multi	Fluke	79-3	69200606	5-Aug-05	5-Aug-06
Meter, Temp/Humid/Barom	Fisher	02-400	01	24-Oct-05	24-Oct-06
Power Supply, AC	California Instruments	1251P	L06429	CNR II	CNR II

* Calibration of equipment past due for re-calibration will be performed expeditiously. If any equipment is found to be out of tolerance at that time, affected customers will be notified accordingly.

6 EMC Test Plan

6.1 Introduction

This manufacturer-supplied document provides a description of the Equipment Under Test (EUT), configuration(s), operating condition(s), and performance acceptance criteria. It is intended to provide the test laboratory with the essential information needed to perform the requested testing.

6.2 Customer

The information in the following tables is required, as it should appear in the final test report.

Table 9 – Customer Information

Company Name	Ortronics Inc.
Web Site	http://www.ortronics.com/
Address 1	125 Eugene O'Neill Drive
City	New London
State	CT
Zip	06320
Phone	860-405-2952
Fax	860-405-2990

Table 10 – Technical Contact Information

Name	Kourosch Parsa
E-mail	Kourosch.parsa@ortronics.com
Phone	860-405-2952
Fax	860-405-2990

6.3 Equipment Under Test (EUT)

The information provided in the following table should be listed as it should appear in the final report. For those products that have only a model name, list the model number as *non-applicable* and vice-versa.

Table 11 – EUT Designation

Product Name	WiJack DUO
System Name	Wireless LAN
Model Number	TBD
Line Cards	NA
Product Description	Wireless Access Point (Dual radio a and b/g bands)

6.3.1 Product Specifications

The information provided in the following table should be listed as it should appear in the final report.

Table 12 – EUT Specifications

Size (in inches)	4.5"H 2.75"W 2"D
Weight (in pounds)	0.2 Lbs.
Power Supply (check all that apply)	Voltage Type <input checked="" type="checkbox"/> DC <input type="checkbox"/> AC
	Operating Voltage 48 v Operating Frequency NA
	Multiple Feeds <input type="checkbox"/> Yes and how many <input checked="" type="checkbox"/> No
	Current (Max) .2 (A)
	Power Consumption (Max loaded) (W)
Is the EUT a frame or a shelf product? (Note: shelf = 36" or less)	<input type="checkbox"/> Table Top <input type="checkbox"/> Rack mount <input type="checkbox"/> Floor standing cabinet <input checked="" type="checkbox"/> Other describe The unit is wall mounted. It is mounted inside a single gang box

6.3.2 Interface Specifications

The information provided in the following table should be listed as it should appear in the final report.

Table 13 – Interface Specifications

Interface Design/ Port Name	Number of this type Interfaces	Cabled with what type of cable?	Is the cable shielded?	What is the maximum potential length of the cable?	Metallic (M), Coax (C) or Fiber (F)?
User port		CAT5	<input type="checkbox"/> Yes <input checked="" type="checkbox"/> No		<input checked="" type="checkbox"/> M <input type="checkbox"/> C <input type="checkbox"/> F
Backbone port		CAT5e CAT6	<input type="checkbox"/> Yes <input checked="" type="checkbox"/> No	80 m	<input type="checkbox"/> M <input type="checkbox"/> C <input type="checkbox"/> F

6.3.3 Technical Description

Compact design fits in a standard single-gang wall outlet

- ▶ AP profile extends 12 mm from wall
- ▶ Dual-radio a/b/g support, with internal antennas
- ▶ Centrally managed thin AP
- ▶ Secure, integrated 10/100 Ethernet port
- ▶ Able to function as a dedicated air monitor
- ▶ Connects to structured cabling with standard 110 termination

Enterprise Performance in a Compact Design

The Wi-Jack Duo is the latest innovation from Ortronics/Legrand, setting the standard for compact, unobtrusive access point design. This new addition to the Wi-Jack family of access points integrates easily into your structured cabling wherever wireless access is desired. Packaged discreetly behind a single gang faceplate, the Duo supports 802.11a/b/g for simultaneous 2.4 and 5 GHz operation at speeds up to 54 Mbps.

The Wi-Jack Duo includes internal tri-band omni-directional antennas mounted safely behind the faceplate; providing optimal performance while blending aesthetically into any environment. The Duo also has an optional embedded 10/100 Ethernet port for network devices such as printers, security cameras and laptop computers. The Wi-Jack Duo is a cost-effective option for any new or retrofit wireless LAN deployment.

Centrally Managed Thin Technology

Unlike conventional APs, Wi-Jack Duos are not overburdened with performing wireless user authentication, encryption, and other resource intensive functions. The Wi-Jack intelligence is centralized within the wireless controller to create a more manageable scalable environment. New standards and feature upgrades are managed centrally at the wireless controller without requiring manual upgrades at each AP. Additional benefits include seamless support for roaming and low-latency handoffs between APs—making the Ortronics solution ideal for handling delay-sensitive applications such as multimedia and voice over wireless. Critical configuration information, such as passwords, network settings or digital certificates, are stored in the controller, not the AP.

Air Monitoring Enhances Security

Functioning as an air monitor, the Wi-Jack Duo allows administrators to monitor and protect the air. When in air monitor mode, the Duo listens on all RF channels to provide detection and protection against unwanted wireless intrusions. Rogue APs can be detected and contained from providing service, while wireless intrusions such as Denial of Service (DoS), Man-in-the-Middle, and other attacks can be detected and thwarted. Air monitors also provide RF monitoring and management capabilities allowing WLAN administrators to capture packets remotely and gain access to valuable RF spectrum information.

Specifications

Antennas

Two tri-band omni-directional

Integrated, non-detachable

Antenna Gain

- ▶ 2.4-2.5GHz / 3 dBi
- ▶ 5.150 GHz / 3.5 dBi
- ▶ 5.350 GHz / 4.3 dBi

Support for radio signal diversity

VSWR <2.5:1

Radio Specs-802.11a

Frequency Bands

- ▶ 5.150 ~ 5.250 GHz (lower band)*
- ▶ 5.250 ~ 5.350 GHz (middle band)*
- ▶ 5.500 - 5.700 GHz (ETSI band)*
- ▶ 5.725 ~ 5.825 GHz (higher band)*

*Country specific

Radio Technology: OFDM

Modulation: BPSK, QPSK, 16-QAM, 64-QAM

MAC: CSMA/CA with ACK

Data Rates: 6, 9, 12, 18, 24, 36, 48, 54 Mbps per channel

Transmit power: user configurable up to 50 mW

Operating Channels

- ▶ US & Canada: 12
- ▶ ETSI: up to 19
 - ▶ Japan: 4

Radio Specs-802.11b

Frequency Band

- ▶ 2.4 ~ 2.483 GHz (US, Canada & ETSI)
 - ▶ 2.4 ~ 2.497 GHz (Japan)

Radio Technology: DSSS

Modulation: CCK, BPSK, QPSK

MAC: CSMA/CA with ACK

Data Rates: 1, 2, 5.5, 11 Mbps per channel

Transmit power: user configurable up to 100 mW

Operating Channels

- ▶ US & Canada: 11
 - ▶ ETSI: 13
 - ▶ Japan: 14

Radio Specs-802.11g

Frequency Band

- ▶ 2.412 ~ 2.462 GHz (US, Canada)
 - ▶ 2.412 ~ 2.472 GHz (ETSI)
 - ▶ 2.412 ~ 2.484 GHz (Japan)

Radio Technology: OFDM

Modulation: CCK, BPSK, QPSK, 16-QAM, 64-QAM

MAC: CSMA/CA with ACK

Data Rates: 6, 9, 12, 18, 24, 36, 48, 54 Mbps per channel

Transmit power: user configurable up to 100 mW

Operating Channels

- ▶ US & Canada: 11
 - ▶ ETSI: 13
 - ▶ Japan: 14

Management

Network-wide AP management via

- ▶ CLI
- ▶ WEB GUI
- ▶ SNMPv3

Encryption Support (AP and wireless controller)
40-bit/64-bit/128-bit/152-bit WEP, TKIP, AES

Interfaces

One 10/100Base-TX RJ-45 auto-sensing Ethernet Interface: (Backbone Port)

- ▶ Autosensing MDI/MDX
- ▶ PoE 48 V DC / 250 mA power-over-Ethernet (802.3af compliant)

One 10/100BaseTX User Port

- ▶ Autosensing MDI/MDIX
- ▶ "Secure-jack" wired port

Mechanical Dimensions
4.50" x 2.75" x 2.21"
Wall single-gang box

Visual Indicators (LEDs)
Green: Ready/power on/off
Blue: 802.11a RF activity
Blue: 802.11b/g RF activity

Power Requirements
48 VDC/250 mA Power-over-Ethernet (802.3af compliant)

Environmental

Temperature

- ▶ Operating: 0 to 40°C
- ▶ Storage: -20 to 85°C

Humidity 5% to 95% (non-condensing)

Communication Standards

Ethernet: IEEE 802.3 / IEEE 802.3u
Power Over Ethernet: IEEE 802.3af (Backbone Connector)
Wireless: IEEE 802.11a/b/g (Wireless Interface)

Safety Standards

UL[®] Listed (UL60950)
UL Listed (Canadian Electrical Code/CSA 22.2 No. 60950)
EN60950 / IEC60950

Electromagnetic Compliance Standards

FCC Part 15 Class B
FCC Part 15 Class C 15.207/15.247
FCC Part 15 Class E 15.407
ICES-003 Class A
RSS 210 (CAN)
EN 61000-3, EN 61000-4-2, EN 61000-4-3, EN 61000-4-4
EN 61000-4-5, EN 61000-4-6, EN 61000-4-8,
EN 61000-4-11
EN 55022, EN55024 (89/336/EEC)
ETS 300 328 (89/336/EEC), ETS 301 489 (89/336/EEC)
ETS 301 893

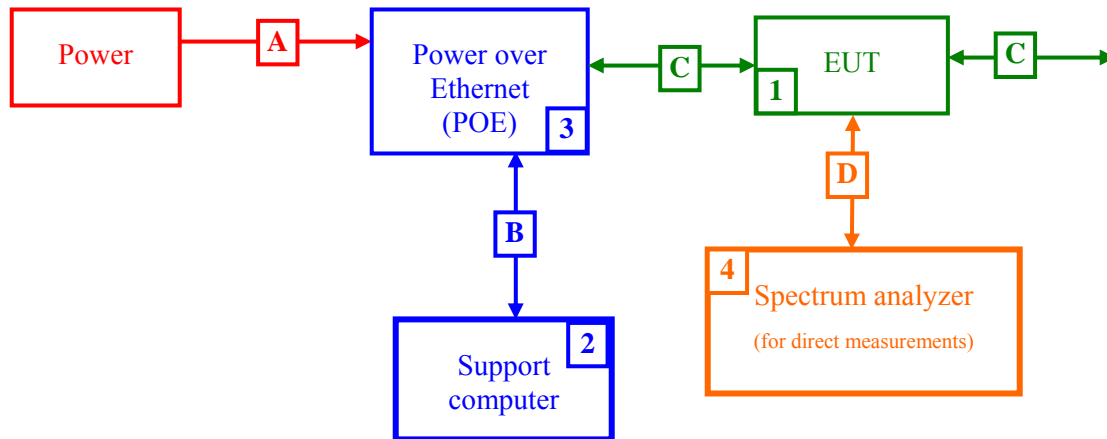

Figure 25 - Block Diagram of EUT Set-Up

Table 14 – Equipment Chassis Shown in Block Diagram

Des.	Manufacturer	Model No.	Description
1	Ortronics	Wireless Lan	EUT
2	IBM	Laptop computer	Support equipment
3	Ortronics	POE	Support equipment
4	HP	7405	Measurement equipment

Table 15 – Cables Shown in Block Diagram

Des.	Cable Name
A	AC Power to POE
B	UTP Ethernet cable – CAT 5
C	UTP Ethernet cable – CAT 5
D	Short coax Adapter cable

6.3.4 Operating Conditions

The standards require that the EUT be tested in a "typical" operating mode consistent with its intended use. Where several operating modes are possible, each should be investigated and the worst case tested. The operating mode should be defined in terms of how the equipment is operating and why it is operating that way. Within the possible modes of operation, the one selected for testing should represent the one that would produce highest emissions. For RF Immunity testing, please state the time required to complete one operation cycle.

6.3.4.1 Software

Under normal operation, the radio operates stand-alone using control firmware operating under embedded Linux. The EUT is then exercised using external PC's connected through the EUT. Windows-based traffic is used to exercise the EUT.

A second mode, which is used only for testing purposes, uses the ART (Atheros Radio Test) program. This is provided by Atheros to licensed users, and allows certain test modes suitable for certification testing.

6.3.4.2 Mode(s)

Provide instructions for setting up the EUT in each operating mode to be investigated.

Operation Mode 1: ART mode

Operation Mode 2: Normal Mode

Ortronics representative [Abicom] will be on site to change modes.

6.4 Equivalent Models

List any product(s) you wish to have evaluated as being "identical" to the equipment that was tested. Common reasons for models being equivalent are:

- Firmware limits configurations (worst case having been tested)
- Printed Circuit Board Options (worst case configurations were determined and supported by test data resulting in non-tested options being allowed for sale)
- Multiple chassis (worst case having been tested)
- Marketing (same model is marketed under different names)

Table 16 - Models Equivalent to EUT

Model	Reason for Equivalence
OR-AP-DUOWJ	Electrically the same [same exact PCBs]
OR-AP-DUO	Electrically the same [same exact PCBs]

6.4.1 Methods of Determining Equivalence

Either of the following methods can be used for including a list of equivalent models into the laboratory test report.

6.4.1.1 Manufacturer's Letter of Attestation [TUC section]

The manufacturer has provided this list of equivalent models and has been included in this report for the convenience of the customer. The laboratory has *not* performed an evaluation of these models and makes no statement regarding the validity of the list.

6.5 Test Specifications

The information provided in the following table should be provided as you would like the product to be evaluated if different from the requirements of the standard.

Table 17 – EUT Designation

Emissions	
Standard	Requirement
FCC part 15.247	Intentional Radiator

Abicom Section:

1. Schematics which shows the frequency determining/ controlling components [crystals]

Schematics are attached.

PoE-Eth Board Schematic Frequencies:

25MHz Crystal (Pg. 1: Y1)

Micrel KS8893 internal clock (generated from 25MHz Crystal): 125MHz (Pg. 1: U8)

3.3V Switching Regulator 180kHz-240kHz (Pg. 2: U4)

1.2V Switching Regulator 2MHz-3MHz (Pg. 2: U1)

Radio Board Frequencies:

Atheros AR5312 internal clock (generated from 40MHz Clock): 180MHz (Pgs. 1,2,7: U1)

40MHz Crystal (Pg. 3: Y1)

2.4GHz Band Channel Frequencies are generated internally in the AR2112 (Pg. 3: U2)

5GHz Band Channel Frequencies are generated internally in the AR5112 (Pg. 4: U3)

2. Frequencies [Ortronics will attach a specification document]

3. Block Diagrams

A Block Diagram is Attached.

4. Operational Description

Description of the circuit functions, signal flows, etc. Works together with block diagram

The block diagram shows the EUT configuration. The EUT is composed of three PC Boards, designated the “PoE/Ethernet/Regulator Board”, “Daughterboard”, and “Radio/MAC/Memory Board” in the drawing.

The PoE/Ethernet/Regulator Board provides power and wired interfaces. The power is supplied via an 802.3af Power-over-Ethernet (PoE) connection, which attaches to the RJ45 plug on the left. The PoE circuit uses switching regulation to convert from 48V to 3.3V, and a second switching regulator converts

from 3.3V to 1.2V. These are used to power the EUT. This board also contains an Ethernet Switch IC, which uses a 25MHz crystal, and associated transformers and common-mode filters.

The Daughterboard provides the interconnects between the PoE and RF boards, and is used to provide a non-PoE user interface, which allows users to connect with CAT5 cabling.

The Radio/MAC/Memory board contains a base-band processor (AR5213), Flash Memory and SDRAM. The processor uses a 40MHz external crystal, and drives two RFIC's which convert to the 2.4GHz band (AR2112) and 5GHz band (AR5112). Each RF section contains RF power amplifiers, LNA's, filtering and detection circuitry. The two RF sections feed a pair of diplexer filters, and an RF switch is used for antenna selection and diversity control. The two RF sections are capable of concurrent operation. Two dual-band antennas are used, which have maximum gains of 3dBi in the 2.4GHz band, 3.9dBi in the 5.25GHz band, and 4.9dBi in the 5.8GHz band.

Describe antenna and ground system as applicable

The EUT uses two dual-band, vertically polarized antennas. The antennas are supplied by a third party, with the following maximum gains:

2.4GHz Band: 3dBi

5.250GHz: 3.9dBi

5.875GHz: 4.9dBi

The antenna structure utilizes a dipole-like structure for each band and is thus ground independent. The dual antennas allow switched diversity, however antenna combining and/or active beam-forming is not possible (only one antenna may transmit at a time for each band).