

Product Data Sheet

Villa™ In-Wall Relay Switch

3145

Centralite®

Last Updated: April 2017

Product Overview

Adding advanced lighting control to your home has never been easier. With the Villa™ In-Wall Relay Switch, users can now have advanced features with easy-to-install, wirelessly communicating switches. The Relay Switch features contemporary styling and convenient wiring connections. It also utilizes the ZigBee HA 1.2 wireless standard. With current-sensing technology, the Villa In-Wall Relay Switch can measure and report how much energy is being used. The switch also features a power amplifier, enabling the device to communicate up to 100 feet (L.O.S.) from other ZigBee devices.

Dimensions

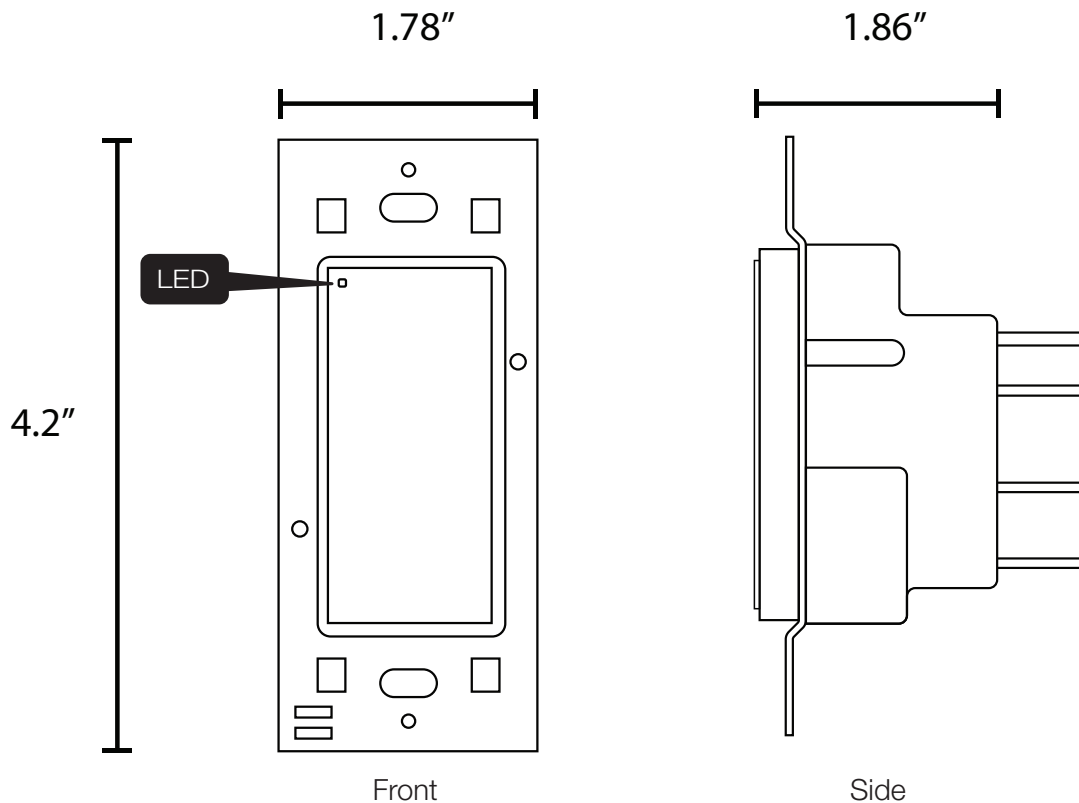

In the Box:

1x - Villa In-Wall Switch 4x - Wire Connectors
2x - Mounting Screws
1x - Installation Guide

Key Features:

- Compatible with 3-, 4-, and 5-Way Circuits
- Easy Install
- Replaces Existing In-Wall Switch
- Advance settings exclusive to Villa Smart Home

Use Cases

- Whole Home Lighting Control
- Lighting Scenes

Whole Home Lighting Control

The Villa Smart Home System is the easy and affordable way to add lighting control to your home or business. Perfect for new construction or retrofit applications.

Lighting Scenes

Set and control scenes by installing Villa In-Wall Switches around your home. Setup morning, goodbye, emergency, and goodnight scenes easily and reliably.

- One-touch “Goodnight” Scene
- Safety and Emergency Lighting

One-touch “Goodnight” Scene

By equipping your home with Villa In-Wall Switches you can “shut down” your home at night with the touch of a single button. Imagine having all interior and exterior lights turn off when you’re ready to go to sleep.

Safety and Emergency Lighting

By equipping your home with Villa In-Wall Switches, you can pair motion and door sensors to automatically trigger your lights in dark hallways or a bathroom at night.

Special Features

Drop-in Switch Replacement

The Villa In-Wall doesn’t require new wiring or special installation tools. Installing the switch is just as easy as installing a regular light switch. Each Villa In-Wall can be installed in less than 5 minutes.

Current-Sensing Circuitry

The Villa In-Wall Switch features current-sensing circuitry for real-time energy usage reporting. The current-sensing feature can also be used to notify users when a device has been turned on or off.

Updatability

The Villa In-Wall Switch supports over-the-air updates providing for seamless upgrades and feature additions without the need for any user interaction.

Getting Started

WARNING! To reduce the risk of serious injury or death, turn power OFF before installing this product.

WARNING! If a direct short is created between the RED terminal and GROUND or NEUTRAL, the Switch will be damaged and unusable.

Step 1: Confirm that the intended installation location conforms to the following requirements:

- Wall box must meet box size requirements specified by the NEC (National Electric Code).
- Installation will be completed according to national and local codes.
- The load being controlled by the device **does not exceed 800W for a single switch.**
- Use 90°C rated or higher wires.

Step 2: To avoid **SERIOUS INJURY** or **DEATH**, turn **OFF** the local electrical power feeding the switch location. To disconnect power turn off the breaker or remove the fuse from the fuse box. Verify that there is no power present using a voltage meter or test light.

Step 3: If you are replacing an existing switch, note which wires are the Ground, Circuit Feed (HOT), Load (Switch Leg), and Neutral.

Step 4: Prepare the wires for connection by stripping off the insulation 5/8-in.

Step 5: Connect the switch.

- Connect **GREEN** wire from switch to **GROUND**
- Connect **BLACK** wire from switch to **HOT FEED**
- Connect **WHITE** wire from switch to **NEUTRAL**
- Connect **RED** wire from switch to **LOAD**

Step 6: Test all connections. Fold wires and push them neatly into the wall box. Align the switch in the wall box with the air gap oriented at the bottom of the switch. Using the supplied screws, secure the switch in the wall box.

Step 7: Verify that the air gap is fully pushed in. Then turn ON circuit breaker or replace the fuse.

Step 8: If the switch is installed properly, the top LED will blink slowly, confirming that the device is powered and operational.

Step 9: You should now be able to control the load by tapping the button.

Troubleshooting

Factory Reset and Rejoin

Pull out air gap. While depressing the switch's top button, press in air gap. When the status LED turns solid, release the button. Repeat the "Getting Started" steps to rejoin the Villa network.

Note

This product will not work in applications where no neutral connection is present.

Compatibility

The Villa In-Wall Switches feature full compatibility with the Villa Smart Home system.

Technical Specifications

Power

120 VAC 60Hz

Supported Loads:

120 VAC 1000W Incandescent

120 VAC 1000W Halogen

120 VAC 1000W Fluorescent

Environmental

Operating Temperature:

0° to +25°C

Shipping / Storage

Temperature: -20° to 50°C

Humidity Range: 0 to 90% RH.
(non-condensing)

Approvals:



Wireless RF

Protocol: ZigBee HA 1.2

TX Strength: +18 dBm

RF Channels: 16

Range: >100 ft. (>30m)

Support

If you have questions about the installation of the Villa Smart Home system please contact Centralite technical support.

Contact

Toll-Free Phone: **1-877-466-5483**

Email: **support@centralite.com**

Web: **www.centralite.com**

Standard Warranty

Centralite offers a standard 24-month limited warranty on the Villa In-Wall Switch

Additional mandatory warranty period in compliance with local law product is being sold.

Contact Sales

For more information about sales or distribution, please contact:

North America

877-466-5483

sales@centralite.com

Centralite Systems, Inc.

1000 Cody Road

Mobile, AL 36695

www.centralite.com

Notice: Any content, factual information, or specifications containing errors in this document are solely inadvertent and will be corrected upon discovery. Specifications for unreleased/planned products are subject to change.

This device complies with Part 15 of the FCC Rules and with Industry Canada licence-exempt RSS Standards. Operation is subject to the following two conditions: (1) This device may not cause harmful interference, and (2) This device must accept any interference received, including interference that may cause undesired operation.

Under Industry Canada regulations, this radio transmitter may only operate using an antenna of a type and maximum (or lesser) gain approved for the transmitter by Industry Canada. To reduce potential radio interference to other users, the antenna type and its gain should be so chosen that the equivalent isotropically radiated power (e.i.r.p.) is not more than that necessary for successful communication.

This equipment complies with FCC and IC radiation exposure limits set forth for an uncontrolled environment. This equipment is in direct contact with the body of the user under normal operating conditions. This transmitter must not be co-located or operating in conjunction with any other antenna or transmitter.

Changes or modifications not expressly approved by Centralite Systems, Inc. could void the user's authority to operate the equipment.

Le présent appareil est conforme aux CNR d'Industrie Canada applicables aux appareils radio exempts de licence. L'exploitation est autorisée aux deux conditions suivantes: (1) l'appareil ne doit pas produire de brouillage, et (2) l'utilisateur de l'appareil doit accepter tout brouillage radioélectrique subi, même si le brouillage est susceptible d'en compromettre le fonctionnement.

Conformément à la réglementation d'Industrie Canada, le présent émetteur radio peut fonctionner avec une antenne d'un type et d'un gain maximal (ou inférieur) approuvé pour l'émetteur par Industrie Canada. Dans le but de réduire les risques de brouillage radioélectrique à l'intention des autres utilisateurs, il faut choisir le type d'antenne et son gain de sorte que la puissance isotrope rayonnée équivalente (p.i.r.e.) ne dépasse pas l'intensité nécessaire à l'établissement d'une communication satisfaisante.