

Product Data Sheet

IRIS Door/Window/Cabinet Sensor

3320-L



Last Updated: May 2015

Product Overview

By detecting the opening and closing of doors and windows, the Iris Door & Window Sensor can wirelessly notify users of arrivals and departures. The Iris Door & Window Sensor consists of a base, mounted to the door or window frame and a magnet to be mounted to the door or window. The Iris Door & Window Sensor is an affordable way to add automation, security, and occupancy sensing to existing connected home systems.

Dimensions

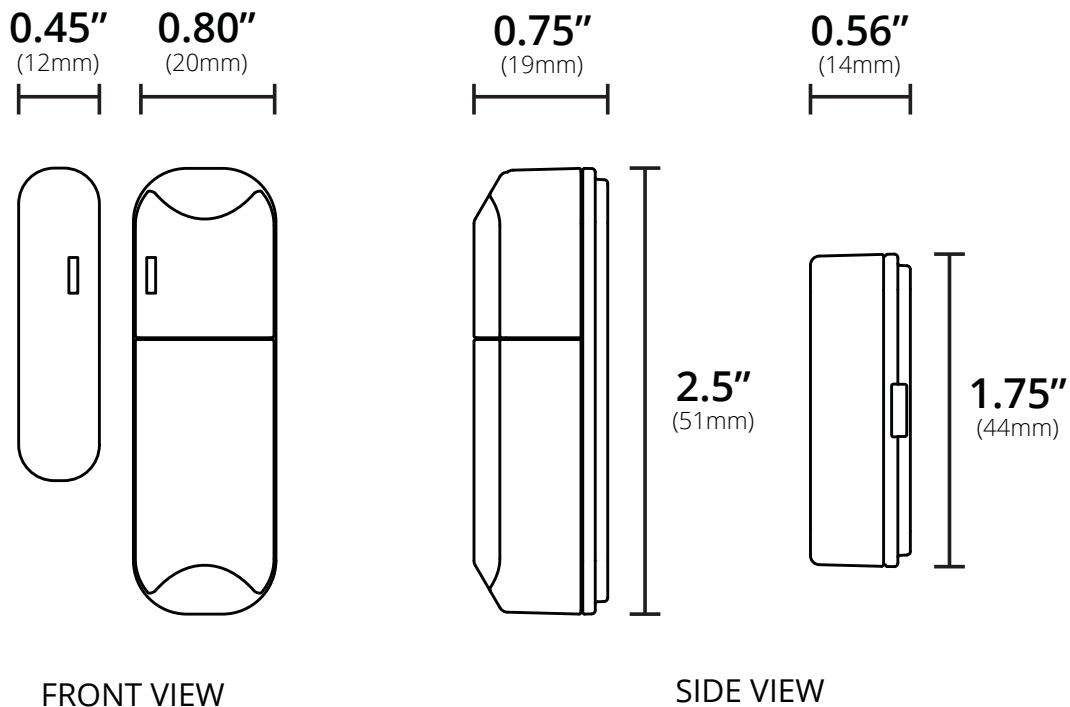

In the Box:

- | | |
|------------------------|--------------------------------------|
| 1x - Iris Door Sensor | 2x - Mounting Tape |
| 1x - Magnet | 1x - CR-2450 Battery (pre-installed) |
| 2x - Mounting Brackets | 1x - Quick Start Guide |

Key Features:

- Hall effect sensor for reliability, long battery life, and increased sensitivity.
- Magnet distance of over 1".
- Easy-to-install mounting plate for sensor and magnet.
- Easy compatibility with other manufacturers' ZigBee HA 1.2 devices.
- Pull-to-pair joining process.
- Over-the-air firmware updates.

Use Cases

- Receive alerts when doors/windows open or close while you're away.
- Trigger "welcome" or "goodbye" scenes.
- Trigger alarm when doors or windows unexpectedly open.
- Automate lights in closets and small rooms

Receive alerts when doors/windows open or close while you're away.

You can use the Iris Door & Window Sensor to notify you when the kids get home from school or when a repair man leaves.

Trigger "welcome" or "goodbye" scenes.

Your house can now welcome you home as you return from work and conserve energy while you're away. Use the Iris Door & Window Sensor in the morning by having it put thermostats in deep setback and turning off unnecessary lighting.

Trigger alarm when doors or windows unexpectedly open.

While you're away or at night while you're asleep, you want more than just notification of an entry/exit—you want an alarm to be triggered. Pair with an alarm or siren to alert your family and police to intruders as well as deterring burglars from entering the home.

Automate lights in closets and small rooms

Place a Iris Door & Window Sensor on closet and pantry doors to trigger lights to automatically turn on and off. This feature provides extra visibility and safety.

Special Features

Hall Effect Sensor

The Iris Door & Window Sensor features a Hall effect sensor for increased sensitivity, reliability, and reduced size. By eliminating the need for a reed switch, the Hall effect sensor has no moving parts, increasing reliability. This feature also increases the battery life of the sensor.

Easy Mounting Options

The Iris Door & Window Sensor can be installed using either adhesive strips or mounting screws (both included). The easy-to-install mounting plate attaches with a single screw and the sensor simply slides into place on the mount.

Pull-to-Pair Join Process

All 3-Series sensors feature "pull-to-pair" joining. The device ships with the battery pre-installed and all that

is needed to begin the joining process is to pull out a small plastic tab from the bottom of the device. There is nothing for the user to take apart or put back together.

ZigBee Home Automation 1.2 Compatibility

The Iris Door & Window Sensor is fully ZigBee HA 1.2 certified and is guaranteed to function with all open, ZigBee HA 1.2-certified hubs and devices.

Superior Range and Updatability

The Iris Door & Window Sensor supports over-the-air updates providing for seamless upgrades and feature additions without the need for any user interaction.

Getting Started

Step 1: Open ZigBee Network for Joining

Using your controller or hub's interface, enable the ZigBee network for joining.

Step 2: Pull Tab from Side of Sensor

Pull the small plastic tab out from the side of the sensor and it will immediately begin searching for a network to join.

Step 3: Finish Joining at Hub (optional)

Some hubs and controllers require additional steps such as naming or categorizing the device.

Troubleshooting

Step 1: Remove and Replace Battery from Device

Slide off the battery cover on the bottom of the device. Remove battery and replace with a new CR-2 battery. Reassemble and test operation.

Step 2: Factory Reset and Rejoin

Remove battery. Insert a paper clip into the reset hole on the side of the device. While holding down the reset button, reinsert battery to factory reset the device. Repeat the "Getting Started" steps to rejoin the ZigBee network.

Compatibility

The Iris Door & Window Sensor features out-of-the-box compatibility with the Lowe's IRIS Hub and any ZigBee HA 1.2-certified hub, controller, bridge, or platform.

Technical Specifications

Power

Rated: 3V
Battery: CR-2 (1x)
Battery Life: Up to 2 years

Environmental

Operating Temperature: 0° to 40°C

Shipping / Storage

Temperature: -20° to 50°C
Humidity Range: 0 to 90% RH.
(non-condensing)

Approvals:



Wireless RF

Protocol: ZigBee HA 1.2
TX Strength: +3 dBm
RF Channels: 16
Range: 130 ft. (40m) LOS

Approvals

This device complies with Part 15 of the FCC rules. Operation is subject to the following two conditions:

- (1) This device may not cause harmful interference and
- (2) This device must accept any interference received, including interference that may cause undesired operation.



Conforms to FCC Part 15B

FCC ID: T3L-SS019

IC: 12192A-SS019



Industry Canada licence-exempt RSS Standards. Operation is subject to the following two conditions: (1) This device may not cause harmful interference, and (2) This device must accept any interference received, including interference that may cause undesired operation.

Under Industry Canada regulations, this radio transmitter may only operate using an antenna of a type and maximum (or lesser) gain approved for the transmitter by Industry Canada. To reduce potential radio interference to other users, the antenna type and its gain should be so chosen that the equivalent isotropically radiated power (e.i.r.p.) is not more than that necessary for successful communication.

This equipment complies with FCC and IC radiation exposure limits set forth for an uncontrolled environment. This equipment is in direct contact with the body of the user under normal operating conditions. This transmitter must not be co-located or operating in conjunction with any other antenna or transmitter.

Changes or modifications not expressly approved by CentraLite Systems, Inc. could void the user's authority to operate the equipment.

Le présent appareil est conforme aux CNR d'Industrie Canada applicables aux appareils radio exempts de licence. L'exploitation est autorisée aux deux conditions suivantes: (1) l'appareil ne doit pas produire de brouillage, et (2) l'utilisateur de l'appareil doit accepter tout brouillage radioélectrique subi, même si le brouillage est susceptible d'en compromettre le fonctionnement.

Conformément à la réglementation d'Industrie Canada, le présent émetteur radio peut fonctionner avec une antenne d'un type et d'un gain maximal (ou inférieur) approuvé pour l'émetteur par Industrie Canada. Dans le but de réduire les risques de brouillage radioélectrique à l'intention des autres utilisateurs, il faut choisir le type d'antenne et son gain de sorte que la puissance isotrope rayonnée équivalente (p.i.r.e.) ne dépasse pas l'intensité nécessaire à l'établissement d'une communication satisfaisante.

Notice: Any content, factual information, or specifications containing errors in this document are solely inadvertent and will be corrected upon discovery. Specifications for unreleased/planned products are subject to change.