





FCC PART 15, SUBPART C
 IC RSS-210, ISSUE 8, DECEMBER 2010
 TEST AND MEASUREMENT REPORT

For

CentraLite Systems, Inc.

1000 Cody Road, Suite A, Mobile, Alabama 36695, USA

FCC ID: T3L-SS005
IC: 12192A-SS005

Report Type: Original Report	Product Type: ZigBee Micro-Motion Sensor
Prepared By Jerry Tong Test Engineer	
Report Number R1502196-247	
Report Date 2015-04-06	
Reviewed By Bo Li RF Lead	
Bay Area Compliance Laboratories Corp. 1274 Anvilwood Avenue, Sunnyvale, CA 94089, USA Tel: (408) 732-9162 Fax: (408) 732-9164	

Note: This test report is prepared for the customer shown above and for the device described herein. It may not be duplicated or used in part without prior written consent from Bay Area Compliance Laboratories Corp. This report **must not** be used by the customer to claim product certification, approval, or endorsement by A2LA*, NIST, or any agency of the Federal Government.

* This report may contain data that are not covered by the A2LA accreditation and are marked with an asterisk "*" see...

TABLE OF CONTENTS

1	General Description.....	5
1.1	Product Description for Equipment Under Test (EUT)	5
1.2	Mechanical Description of EUT	5
1.3	Objective.....	5
1.4	Related Submittal(s)/Grant(s)	5
1.5	Test Methodology	5
1.6	Measurement Uncertainty	5
1.7	Test Facility	6
2	System Test Configuration.....	7
2.1	Justification.....	7
2.2	EUT Exercise Software.....	7
2.3	Equipment Modifications.....	7
2.4	Local Support Equipment	7
2.5	EUT Internal Configuration Details.....	7
2.6	Interface Ports and Cables	7
2.7	Power Supply List and Details.....	7
3	Summary of Test Results	8
4	FCC §15.247 (i), §2.1091 & IC RSS-102 – RF Exposure.....	9
4.1	Applicable Standards	9
4.2	MPE Prediction.....	10
4.3	MPE Results	10
5	FCC §15.203 & IC RSS-Gen §8.3 – Antenna Requirements	11
5.1	Applicable Standards	11
5.2	Antenna Description	11
6	FCC §15.209, §15.247(d) & IC RSS-210 §A8.5 – Spurious Radiated Emissions.....	12
6.1	Applicable Standards	12
6.2	Test Setup	13
6.3	Test Procedure	14
6.4	Corrected Amplitude & Margin Calculation.....	14
6.5	Test Equipment List and Details.....	15
6.6	Test Environmental Conditions	15
6.7	Summary of Test Results.....	16
6.8	Radiated Emissions Test Results	17
7	FCC§15.247(a)(2) & IC RSS-210 §A8.2 – 6 dB & 99% Emission Bandwidth	20
7.1	Applicable Standards	20
7.2	Measurement Procedure.....	20
7.3	Test Equipment List and Details.....	20
7.4	Test Environmental Conditions	20
7.5	Test Results.....	21
8	FCC §15.247(b) & IC RSS-210 §A8.4 (4) – Peak Output Power Measurement.....	23
8.1	Applicable Standard.....	23
8.2	Measurement Procedure.....	23
8.3	Test Equipment List and Details.....	23
8.4	Test Environmental Conditions	23
8.5	Test Results.....	24
9	FCC §15.247(d) & IC RSS-210 §A8.5 – 100 kHz Bandwidth of Band Edges.....	26
9.1	Applicable Standard.....	26
9.2	Measurement Procedure.....	26
9.3	Test Equipment List and Details.....	26
9.4	Test Environmental Conditions	26

9.5 Test Results..... 27

10 FCC §15.247(e) & IC RSS-210 §A8.2 (b) – Power Spectral Density 28

10.1 Applicable Standard..... 28

10.2 Measurement Procedure..... 28

10.3 Test Equipment List and Details..... 28

10.4 Test Environmental Conditions 28

10.5 Test Results..... 29

11 Exhibit A – FCC & IC Equipment Labeling Requirements 31

11.1 FCC ID Label Requirements 31

11.2 IC Label Requirements 31

11.3 FCC ID & IC Label Contents and Location..... 32

12 Exhibit B – Test Setup Photographs 33

12.1 Radiated Emission below 1 GHz Front View 33

12.2 Radiated Emission below 1 GHz Rear View 33

12.3 Radiated Emission above 1 GHz Front View 34

12.4 Radiated Emission above 1 GHz Rear View 34

13 Exhibit C – EUT Photographs..... 35

13.1 EUT Top View..... 35

13.2 EUT Rear View 35

13.3 EUT Open Case View..... 36

13.4 Main Board Top View 36

13.5 Main Board Rear View 37

DOCUMENT REVISION HISTORY

Revision Number	Report Number	Description of Revision	Date of Revision
0	R1502196-247	Original Report	2015-04-06

1 General Description

1.1 Product Description for Equipment Under Test (EUT)

This test and measurement report was prepared on behalf of *CentraLite Systems, Inc.*, and their product *FCC ID: T3L-SS005, IC: 12192A-SS005; model: 3326*, as the “EUT” (Equipment Under Testing) as referred to in this report. The EUT is a 2.4 GHz ZigBee Micro-Motion Sensor.

1.2 Mechanical Description of EUT

The EUT measures approximately 4.5 cm (L) x 4.5 cm (W) x 2.2 cm (H) and weighs 0.05 kg.

Note: The EUT was tested without enclosure.

The test data gathered are from typical production sample, serial number: 3328, assigned by client.

1.3 Objective

This report is prepared on behalf of *CentraLite Systems, Inc.* in accordance with Part 2, Subpart J, and Part 15, Subparts B and C of the Federal Communication Commission’s rules.

The objective is to determine compliance with FCC Part 15.247 rules and IC RSS-210 rules for Output Power, Antenna Requirements, 6 dB Bandwidth, and power spectral density, 100 kHz Bandwidth of Band Edges Measurement, Spurious Emissions, Conducted and Radiated Spurious Emissions.

1.4 Related Submittal(s)/Grant(s)

N/A

1.5 Test Methodology

All measurements contained in this report were conducted in accordance with ANSI C63.10-2013, American National Standard for Methods of Measurement of Radio-Noise Emissions from Low-Voltage Electrical and Electronic Equipment in the range of 9 kHz to 40 GHz and FCC KDB 558074 D01 DTS Meas Guidance v03r02: Guidance for Performing Compliance Measurements on Digital Transmission Systems (DTS) Operating Under §15.247

1.6 Measurement Uncertainty

All measurements involve certain levels of uncertainties, especially in the field of EMC. The factors contributing to uncertainties are spectrum analyzer, cable loss, antenna factor calibration, antenna directivity, antenna factor variation with height, antenna phase center variation, antenna factor frequency interpolation, measurement distance variation, site imperfections, mismatch (average), and system repeatability.

The following calculation follows the procedures as set forth in clause 7.2.3, ETSI TR 100 028-1 V1.4.1 (2001-12), the expression of Uncertainty in Radiated RF Testing is in accordance to ISO/IEC 17025 and TR 100 028-1 V1.4.1 (2001-12).

The expanded Measurement Uncertainty value having a confidence factor of 95%, is within a range of 5.48 dB. This means that the value of conducted RF carrier power test will be within +/- 2.74 dB of the measuring radiated emissions power versus the expected value.

The expected value is defined as the power at the antenna of the Transmitter under Test.

1.7 Test Facility

Bay area compliance Laboratories Corp. (BACL) is:

1- An independent Commercial Test Laboratory accredited to **ISO 17025: 2005** by **A2LA**, in the fields of: Electromagnetic Compatibility & Telecommunications covering Emissions, Immunity, Radio, RF Exposure, Safety and Telecom. This includes NEBS (Network Equipment Building System), Wireless RF, Telecommunications Terminal Equipment (TTE); Network Equipment; Information Technology Equipment (ITE); Medical Electrical Equipment; Industrial, Commercial, and Medical Test Equipment; Professional Audio and Video Equipment; Electronic (Digital) Products; Industrial and Scientific Instruments; Cabled Distribution Systems and Energy Efficiency Lighting.

2- An ENERGY STAR Recognized Laboratory, for the LM80 Testing, a wide variety of Luminaires and Computers.

3- A NIST Designated Phase-I and Phase-II CAB including: ACMA (Australian Communication and Media Authority), BSMI (Bureau of Standards, Metrology and Inspection of Taiwan), IDA (Infocomm Development Authority of Singapore), IC(Industry Canada), Korea (Ministry of Communications Radio Research Laboratory), NCC (Formerly DGT; Directorate General of Telecommunication of Chinese Taipei) OFTA (Office of the Telecommunications Authority of Hong Kong), Vietnam, VCCI - Voluntary Control Council for Interference of Japan and a designated EU CAB (Conformity Assessment Body) (Notified Body) for the EMC and R&TTE Directives.

4- A Product Certification Body accredited to **ISO Guide 65: 1996** by **A2LA** to certify:

1- Unlicensed, Licensed radio frequency devices and Telephone Terminal Equipment for the FCC. Scope A1, A2, A3, A4, B1, B2, B3, B4 & C.

2. Radio Standards Specifications (RSS) in the Category I Equipment Standards List and All Broadcasting Technical Standards (BETS) in Category I Equipment Standards List for Industry Canada.

3. Radio Communication Equipment for Singapore.

4. Radio Equipment Specifications, GMDSS Marine Radio Equipment Specifications, and Fixed Network Equipment Specifications for Hong Kong.

5. Japan MIC Telecommunication Business Law (A1, A2) and Radio Law (B1, B2 and B3).

6. Audio/Video, Battery Charging Systems, Computers, Displays, Enterprise Servers, Imaging Equipment, Set-Top Boxes, Telephony, Televisions, Ceiling Fans, CFLs (Including GU24s), Decorative Light Strings, Integral LED Lamps, Luminaires, Residential Ventilating Fans.

The test site used by BACL Corp. to collect radiated and conducted emissions measurement data is located at its facility in Sunnyvale, California, USA.

The test site at BACL Corp. has been fully described in reports submitted to the Federal Communication Commission (FCC) and Voluntary Control Council for Interference (VCCI). The details of these reports have been found to be in compliance with the requirements of Section 2.948 of the FCC Rules on February 11 and December 10, 1997, and Article 8 of the VCCI regulations on December 25, 1997. The test site also complies with the test methods and procedures set forth in CISPR 22:2008 §10.4 for measurements below 1 GHz and §10.6 for measurements above 1 GHz as well as ANSI C63.10-2013, ANSI C63.10-2013, TIA/EIA-603 & CISPR 24:2010.

The Federal Communications Commission and Voluntary Control Council for Interference have the reports on file and they are listed under FCC registration number: 90464 and VCCI Registration No.: A-0027. The test site has been approved by the FCC and VCCI for public use and is listed in the FCC Public Access Link (PAL) database.

Additionally, BACL Corp. is an American Association for Laboratory Accreditation (A2LA) accredited laboratory (Lab Code 3297-02). The current scope of accreditations can be found at

<http://www.a2la.org/scopepdf/3297-02.pdf?CFID=1132286&CFTOKEN=e42a3240dac3f6ba-6DE17DCB-1851-9E57-477422F667031258&jsessionid=8430d44f1f47cf2996124343c704b367816b>

2 System Test Configuration

2.1 Justification

The EUT was configured for testing according to ANSI C63.10-2013 and FCC KDB 558074 D01 DTS Meas Guidance v03r02.

The EUT was tested in a testing mode to represent worst-case results during the final qualification test.

The worst-case data rates are determined to be as follows for each mode based upon investigation by measuring the average power, peak power and PPSD across all data rates bandwidths, and modulations.

2.2 EUT Exercise Software

EUT was exercised using putty.exe and verified by Jerry Tong.

2.3 Equipment Modifications

No modifications were made to the EUT.

2.4 Local Support Equipment

Manufacturer	Description	Model	Serial Number
Hewlett-Packard	Power Supply	623B	2003A05705
Dell	Laptop	Latitude D 610	-

2.5 EUT Internal Configuration Details

Manufacturer	Description	Model	Serial Number
Silicon Labs	SkyWorks ZigBee Radio	EM357/SE2432L	-
Silicon Labs	CPU	Si4355	-

2.6 Interface Ports and Cables

Description	Length	From	To
USB cable	1 m	Debug Adapter	EUT
Ethernet Cable	1 m	Debug Adapter	Laptop

2.7 Power Supply List and Details

No power supplies were required for the EUT.

3 Summary of Test Results

Results reported relate only to the product tested.

FCC & IC Rules	Description of Test	Results
FCC §15.247(i), §2.1091 IC RSS-102	RF Exposure	Compliant
FCC §15.203 IC RSS-Gen §8.3	Antenna Requirement	Compliant
FCC §15.207(a) IC RSS-Gen §8.8	AC Line Conducted Emissions	N/A ¹
FCC §15.205 IC RSS-210 §2.2	Restricted Bands	Compliant
FCC §15.209, §15.247 (d) IC RSS-Gen §8.9	Radiated Spurious Emissions	Compliant
FCC §15.247 (d) IC RSS-Gen §8.9	Conducted Transmitter Spurious Emission	N/A ²
FCC §15.247(a)(2) IC RSS-210 §A8.2	6 dB Emission Bandwidth	Compliant
FCC §15.247(b)(3) IC RSS-210 §A8.4	Maximum Peak Output Power	Compliant
FCC §15.247(d) IC RSS-210 §A8.5	100 kHz Bandwidth of Frequency Band Edge	Compliant
FCC §15.247(e) IC RSS-210 §A8.2(b)	Power Spectral Density	Compliant

¹ The EUT was battery powered.

² The EUT had no antenna port.

4 FCC §15.247 (i), §2.1091 & IC RSS-102 – RF Exposure

4.1 Applicable Standards

According to FCC §15.247(i) and §1.1307(b)(1), systems operating under the provisions of this section shall be operated in a manner that ensures that the public is not exposed to radio frequency energy level in excess of the Commission’s guidelines.

Limits for General Population/Uncontrolled Exposure

Frequency Range (MHz)	Electric Field Strength (V/m)	Magnetic Field Strength (A/m)	Power Density (mW/cm ²)	Averaging Time (minutes)
Limits for General Population/Uncontrolled Exposure				
0.3-1.34	614	1.63	* (100)	30
1.34-30	824/f	2.19/f	* (180/f ²)	30
30-300	27.5	0.073	0.2	30
300-1500	/	/	f/1500	30
1500-100,000	/	/	1.0	30

f = frequency in MHz

* = Plane-wave equivalent power density

Before equipment certification is granted, the procedure of IC RSS-102 must be followed concerning the exposure of humans to RF field

According to IC RSS-102 Issue 4 section 4.2, RF limits used for general public will be applied to the EUT.

Frequency Range (MHz)	Electric Field (V/m rms)	Magnetic Field (A/m rms)	Power Density (W/m ²)	Time Averaging (min)
0.003 - 1	280	2.19	-	6
1 - 10	280 / f	2.19 / f	-	6
10 - 30	28	2.19 / f	-	6
30 – 300	28	0.073	2*	6
300 – 1 500	1.585 f ^{0.5}	0.0042 f ^{0.5}	f / 150	6
1 500 – 15 000	61.4	0.163	10	6
15 000 – 150 000	61.4	0.163	10	616000 / f ^{1.2}
150 000- 300 000	0.158 f ^{0.5}	4.21 x 10 ⁻⁴ f ^{0.5}	6.67 x 10 ⁻⁵ f	616000 / f ^{1.2}

Note: f is frequency in MHz

* = Power density limit is applicable at frequencies greater than 100 MHz

4.2 MPE Prediction

Predication of MPE limit at a given distance, Equation from OET Bulletin 65, Edition 97-01

$$S = PG/4\pi R^2$$

Where: S = power density

P = power input to antenna

G = power gain of the antenna in the direction of interest relative to an isotropic radiator

R = distance to the center of radiation of the antenna

4.3 MPE Results

<u>Maximum peak output power at antenna input terminal (dBm):</u>	<u>5.188</u>
<u>Maximum peak output power at antenna input terminal (mW):</u>	<u>3.302</u>
<u>Prediction distance (cm):</u>	<u>20</u>
<u>Prediction frequency (MHz):</u>	<u>2405</u>
<u>Maximum Antenna Gain, typical (dBi):</u>	<u>3.3</u>
<u>Maximum Antenna Gain (numeric):</u>	<u>2.138</u>
<u>Power density of prediction frequency at 20.0 cm (mW/cm²):</u>	<u>0.001405</u>
<u>Power density of prediction frequency at 20.0 cm (W/m²):</u>	<u>0.01405</u>
<u>MPE limit for uncontrolled exposure at prediction frequency (mW/cm²):</u>	<u>1.0</u>
<u>MPE limit for uncontrolled exposure at prediction frequency (W/m²):</u>	<u>5.4</u>

The device is compliant with the requirement MPE limit for uncontrolled exposure. The maximum power density at the distance of 20 cm is 0.001405 mW/cm² (0.01405 W/m²). Limit is 1.0 mW/cm² (5.4 W/m²).

5 FCC §15.203 & IC RSS-Gen §8.3 – Antenna Requirements

5.1 Applicable Standards

According to FCC §15.203, an intentional radiator shall be designed to ensure that no antenna other than that furnished by the responsible party shall be used with the device. The use of a permanently attached antenna or of an antenna that uses a unique coupling to the intentional radiator shall be considered sufficient to comply with the provisions of this Section. The manufacturer may design the unit so that a broken antenna can be replaced by the user, but the use of a standard antenna jack or electrical connector is prohibited.

According to IC RSS-Gen §8.3: Transmitter Antenna

The applicant for equipment certification, as per RSP-100, must provide a list of all antenna types that may be used with the licence-exempt transmitter, indicating the maximum permissible antenna gain (in dBi) and the required impedance for each antenna.

Licence-exempt transmitters that have received equipment certification may operate with different types of antennas. However, it is not permissible to exceed the maximum equivalent isotropically radiated power (e.i.r.p.) limits specified in the applicable standard (RSS) for the licence-exempt apparatus.

5.2 Antenna Description

The EUT uses a trace antenna, which complies with the antenna requirement. And the antenna gain is 3.3 dBi. Please refer to the internal photos.

6 FCC §15.209, §15.247(d) & IC RSS-210 §A8.5 – Spurious Radiated Emissions

6.1 Applicable Standards

As per FCC §15.35(d): Unless otherwise specified, on any frequency or frequencies above 1000 MHz, the radiated emission limits are based on the use of measurement instrumentation employing an average detector function. Unless otherwise specified, measurements above 1000 MHz shall be performed using a minimum resolution bandwidth of 1 MHz.

As per FCC §15.209(a) and RSS-210: Except as provided elsewhere in this Subpart, the emissions from an intentional radiator shall not exceed the field strength levels specified in the following table

Frequency (MHz)	Field Strength (micro volts/meter)	Measurement Distance (meters)
0.009 - 0.490	2400/F(kHz)	300
0.490 - 1.705	24000/F(kHz)	30
1.705 - 30.0	30	30
30 - 88	100**	3
88 - 216	150**	3
216 - 960	200**	3
Above 960	500	3

** Except as provided in paragraph (g), fundamental emissions from intentional radiators operating under this Section shall not be located in the frequency bands 54-72 MHz, 76-88 MHz, 174-216 MHz or 470-806 MHz. However, operation within these frequency bands is permitted under other sections of this Part, e.g., Sections 15.231 and 15.241.

As Per FCC §15.205(a) except as show in paragraph (d) of this section, only spurious emissions are permitted in any of the frequency bands listed below:

MHz	MHz	MHz	GHz
0.090 – 0.110	16.42 – 16.423	960 – 1240	4.5 – 5.15
0.495 – 0.505	16.69475 – 16.69525	1300 – 1427	5.35 – 5.46
2.1735 – 2.1905	25.5 – 25.67	1435 – 1626.5	7.25 – 7.75
4.125 – 4.128	37.5 – 38.25	1645.5 – 1646.5	8.025 – 8.5
4.17725 – 4.17775	73 – 74.6	1660 – 1710	9.0 – 9.2
4.20725 – 4.20775	74.8 – 75.2	1718.8 – 1722.2	9.3 – 9.5
6.215 – 6.218	108 – 121.94	2200 – 2300	10.6 – 12.7
6.26775 – 6.26825	123 – 138	2310 – 2390	13.25 – 13.4
6.31175 – 6.31225	149.9 – 150.05	2483.5 – 2500	14.47 – 14.5
8.291 – 8.294	156.52475 – 156.52525	2690 – 2900	15.35 – 16.2
8.362 – 8.366	156.7 – 156.9	3260 – 3267	17.7 – 21.4
8.37625 – 8.38675	162.0125 – 167.17	3.332 – 3.339	22.01 – 23.12
8.41425 – 8.41475	167.72 – 173.2	3 3458 – 3 358	23.6 – 24.0
12.29 – 12.293	240 – 285	3.600 – 4.400	31.2 – 31.8
12.51975 – 12.52025	322 – 335.4		36.43 – 36.5
12.57675 – 12.57725	399.9 – 410		Above 38.6
13.36 – 13.41	608 – 614		

As per FCC §15.247 (d) In any 100 kHz bandwidth outside the frequency band in which the spread spectrum or digitally modulated intentional radiator is operating, the radio frequency power that is produced by the intentional radiator shall be at least 20 dB below that in the 100 kHz bandwidth within the band that contains the highest level of the desired power, based on either an RF conducted or a radiated measurement, provided the transmitter demonstrates compliance with the peak conducted power limits. If the transmitter complies with the conducted power limits based on the use of RMS averaging over a time interval, as permitted under paragraph (b)(3) of this section, the attenuation required under this paragraph shall be 30 dB instead of 20 dB. Attenuation below the general limits specified in §15.209(a) is not required. In addition, radiated emissions which fall in the restricted bands, as defined in §15.205(a), must also comply with the radiated emission limits specified in §15.209(a) (see §15.205(c)).

As per IC RSS-210 A8.5 Out-of-band Emissions, In any 100 kHz bandwidth outside the frequency band in which the spread spectrum or digitally modulated device is operating, the RF power that is produced shall be at least 20 dB below that in the 100 kHz bandwidth within the band that contains the highest level of the desired power, based on either an RF conducted or a radiated measurement, provided that the transmitter demonstrates compliance with the peak conducted power limits. If the transmitter complies with the conducted power limits based on the use of root-mean-square averaging over a time interval, as permitted under Section A8.4 (4), the attenuation required shall be 30 dB instead of 20 dB. Attenuation below the general field strength limits specified in RSS-Gen is not required.

6.2 Test Setup

The radiated emissions tests were performed in the 5-meter Chamber, using the setup in accordance with ANSI C63.10-2013. The specification used was the FCC 15 Subpart C and IC RSS-Gen limits.

The spacing between the peripherals was 10 centimeters.

External I/O cables were draped along the edge of the test table and bundle when necessary.

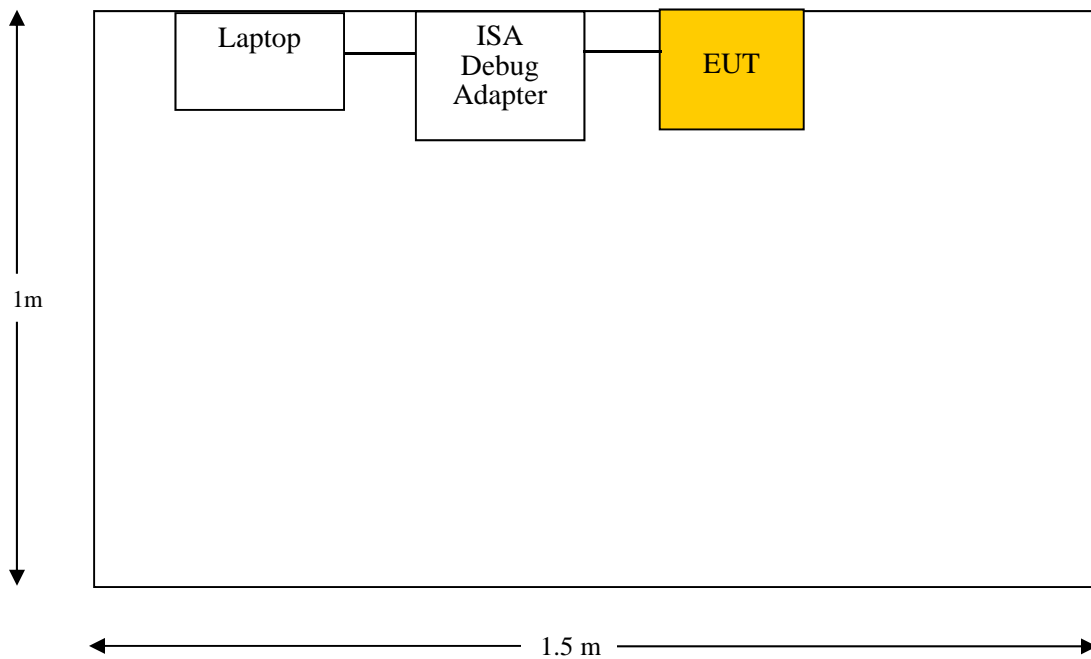

Test Setup Block Diagram

6.3 Test Procedure

The measurements are based on FCC KDB 558074 D01 DTS Meas Guidance v03r02: Guidance for Performing Compliance Measurements on Digital Transmission Systems (DTS) Operating Under §15.247 section 11: Emissions in non-restricted frequency bands and section 12: Emissions in restricted frequency bands. As well as ANSI C63.10: 2013 as described below:

For the radiated emissions test, the EUT host was connected to support equipment.

Maximizing procedure was performed on the highest emissions to ensure that the EUT complied with all installation combinations.

The EUT is set 3 meter away from the testing antenna, which is varied from 1-4 meter, and the EUT is placed on a turntable, which is 0.8 meter for below 1GHz and 1.5 meter for above 1GHz above ground plane, the table shall be rotated for 360 degrees to find out the highest emission. The receiving antenna should be changed the polarization both of horizontal and vertical.

The spectrum analyzer or receiver is set as:

Below 1000 MHz:

$$\text{RBW} = 100 \text{ kHz} / \text{VBW} = 300 \text{ kHz} / \text{Sweep} = \text{Auto}$$

Above 1000 MHz:

- (1) Peak: RBW = 1MHz / VBW = 3MHz / Sweep = Auto
- (2) Average: RBW = 1MHz / VBW = 10Hz / Sweep = Auto

6.4 Corrected Amplitude & Margin Calculation

The Corrected Amplitude (CA) is calculated by adding the Antenna Factor (AF), the Cable Loss (CL), the Attenuator Factor (Atten) and subtracting the Amplifier Gain (Ga) to indicated Amplitude (Ai) reading. The basic equation is as follows:

$$\text{CA} = \text{Ai} + \text{AF} + \text{CL} + \text{Atten} - \text{Ga}$$

For example, a corrected amplitude of 40.3 dBuV/m = Indicated Reading (32.5 dBuV) + Antenna Factor (+23.5dB) + Cable Loss (3.7 dB) + Attenuator (10 dB) - Amplifier Gain (29.4 dB)

The “**Margin**” column of the following data tables indicates the degree of compliance within the applicable limit. For example, a margin of -7 dB means the emission is 7 dB below the maximum limit. The equation for margin calculation is as follows:

$$\text{Margin} = \text{Corrected Amplitude} - \text{Limit}$$

6.5 Test Equipment List and Details

Manufacturer	Description	Model No.	Serial No.	Calibration Date	Calibration Interval
Sunol Science Corp	System Controller	SC99V	122303-1	N/A	N/A
Sunol Sciences	Antenna, Biconi-Log	JB3	A020106-2	2014-09-17	1 year
Hewlett Packard	Pre-amplifier 1-26.5 GHz	8447D	2944A06639	2014-04-26	1 year
HP/ Agilent	Pre Amplifier	8449B OPT HO2	3008A0113	2014-03-10	1 year
E-meca	10 dB Attenuator	18N-10-294	64671	N/A	N/A
Micro Tronics	Band Reject Filter	BRM50701	160	N/A	N/A
IW Microwave	Cable	SPS-2303-3840-SPS	DC1438	N/A	N/A
Hewlett Packard	Cable	-	C0003	N/A	N/A
Agilent	Analyzer, Spectrum	E4440A	MY44303352	2014-11-13	1 year
Eaton	Antenna, Horn	96001	2617	2014-11-18	1 year
Rohde & Schwarz	Receiver, EMI Test	ESCI 1166.5950K03	100044	2014-07-17	1 year

Statement of Traceability: BACL attests that all calibrations have been performed per the A2LA requirements, traceable to NIST.

6.6 Test Environmental Conditions

Temperature:	17 °C
Relative Humidity:	46 %
ATM Pressure:	101.9 kPa

The testing was performed by Jerry Tong on 2015-03-10 in 5 m chamber 2.

6.7 Summary of Test Results

According to the data hereinafter, the EUT complied with the FCC Title 47, Part 15C and IC RSS Gen §8.5 standard's radiated emissions limits, and had the worst margin of:

30-1000 MHz:

Mode: Transmitting			
Margin (dB)	Frequency (MHz)	Polarization (Horizontal/Vertical)	Range
-7.06	499.9938	Vertical	30-1000 MHz

Above 1 GHz:

Mode: Transmitting			
Margin (dB)	Frequency (MHz)	Polarization (Horizontal/Vertical)	Range
-0.415	2483.5	Horizontal	1000-25000 MHz

Please refer to the following table and plots for specific test result details

6.8 Radiated Emissions Test Results

1) 30 MHz – 1 GHz, Measured at 3 meters

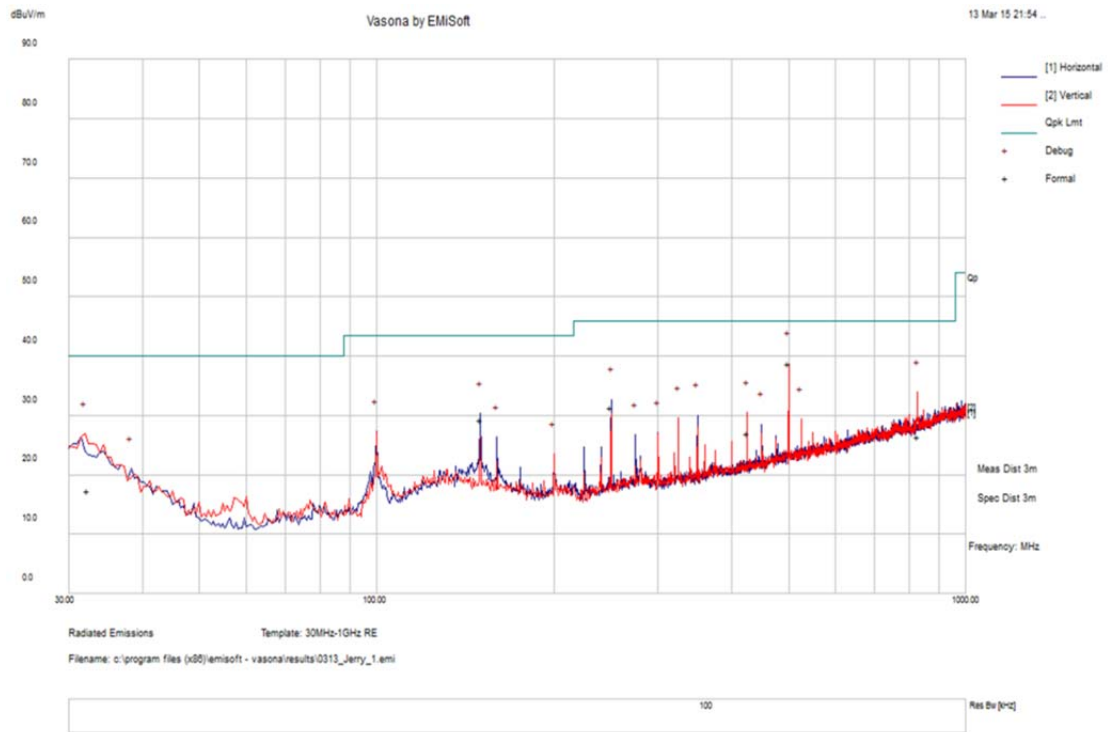

Worst case:

Frequency (MHz)	Corrected Amplitude (dB μ V/m)	Antenna Height (cm)	Antenna Polarity (H/V)	Turntable Azimuth (degrees)	Limit (dB μ V/m)	Margin (dB)	Comments (PK/QP/Ave)
499.9938	38.94	125	V	104	46	-7.06	QP
827.176	26.48	101	V	8	46	-19.52	QP
32.3	17.36	148	V	194	40	-22.64	QP
149.998	29.35	141	H	128	43.5	-14.15	QP
250.0183	31.49	164	H	250	46	-14.51	QP
425.0295	27.14	100	V	136	46	-18.86	QP

2) Above 1 GHz, Measured at 3 meters

Frequency (MHz)	S.A. Reading (dBµV)	Turntable Azimuth (degrees)	Test Antenna			Cable Loss (dB)	Pre-Amp. (dB)	Cord. Reading (dBµV/m)	FCC/IC		Comments
			Height (cm)	Polarity (H/V)	Factor (dB/m)				Limit (dBµV/m)	Margin (dB)	
Low Channel 2405 MHz, measured at 3 meters											
2405	64.76	202	154	V	28.383	2.865	0	96.008	-	-	Peak
2405	72.36	277	151	H	28.417	2.865	0	103.642	-	-	Peak
2405	61.93	202	154	V	28.383	2.865	0	93.178	-	-	Ave
2405	69.56	277	151	H	28.417	2.865	0	100.842	-	-	Ave
2390	26.63	202	154	V	28.383	2.865	0	57.878	74	-16.122	Peak
2390	26.83	277	151	H	28.417	2.865	0	58.112	74	-15.888	Peak
2390	12.73	202	154	V	28.383	2.865	0	43.978	54	-10.022	Ave
2390	13.56	277	151	H	28.417	2.865	0	44.842	54	-9.158	Ave
4810	48.51	70	150	V	32.897	4.297	35.663	50.041	74	-23.959	Peak
4810	49.95	254	165	H	32.897	4.297	35.663	51.481	74	-22.519	Peak
4810	35.43	70	150	V	32.897	4.297	35.663	36.961	54	-17.039	Ave
4810	38.64	254	165	H	32.897	4.297	35.663	40.171	54	-13.829	Ave
7215	47.95	87	150	V	37.444	5.675	36.064	55.005	76.008	-21.003	Peak
7215	46.63	289	150	H	37.442	5.675	36.064	53.683	83.642	-29.959	Peak
7215	35	87	150	V	37.444	5.675	36.064	42.055	73.178	-31.123	Ave
7215	33.45	289	150	H	37.442	5.675	36.064	40.503	80.842	-40.339	Ave
9620	45.27	0	150	V	38.830	8.704	35.900	56.904	76.008	-19.104	Peak
9620	45.97	174	150	H	38.834	8.704	35.900	57.608	83.642	-26.034	Peak
9620	30.64	0	150	V	38.830	8.704	35.900	42.274	73.178	-30.904	Ave
9620	32.27	174	150	H	38.834	8.704	35.900	43.908	80.842	-36.934	Ave
Middle Channel 2440 MHz, measured at 3 meters											
2440	63.55	61	196	V	28.383	2.865	0	94.798	-	-	Peak
2440	70.62	38	154	H	28.417	2.865	0	101.902	-	-	Peak
2440	61.28	61	196	V	28.383	2.865	0	92.528	-	-	Ave
2440	68.38	38	154	H	28.417	2.865	0	99.662	-	-	Ave
4880	49.2	25	151	V	33.119	4.404	35.896	50.827	74	-23.173	Peak
4880	50.93	360	150	H	33.354	4.404	35.896	52.792	74	-21.208	Peak
4880	37.52	25	151	V	33.119	4.404	35.896	39.147	54	-14.853	Ave
4880	39.31	360	150	H	33.354	4.404	35.896	41.172	54	-12.828	Ave
7320	47.08	275	156	V	37.242	5.788	35.958	54.152	74	-19.848	Peak
7320	45.68	282	150	H	37.356	5.788	35.958	52.866	74	-21.134	Peak
7320	33.48	275	156	V	37.242	5.788	35.958	40.552	54	-13.448	Ave
7320	30.92	282	150	H	37.356	5.788	35.958	38.106	54	-15.894	Ave
9760	46.43	0	150	V	38.908	8.157	36.032	57.464	74.798	-17.334	Peak
9760	48.42	281	184	H	38.913	8.157	36.032	59.459	81.902	-22.443	Peak
9760	31.13	0	150	V	38.908	8.157	36.032	42.164	72.528	-30.364	Ave
9760	34.97	281	184	H	38.913	8.157	36.032	46.009	79.662	-33.653	Ave

Frequency (MHz)	S.A. Reading (dBµV)	Turntable Azimuth (degrees)	Test Antenna			Cable Loss (dB)	Pre-Amp. (dB)	Cord. Reading (dBµV/m)	FCC/IC		Comments
			Height (cm)	Polarity (H/V)	Factor (dB/m)				Limit (dBµV/m)	Margin (dB)	
High Channel 2480 MHz, measured at 3 meters											
2480	58.66	132	168	V	29.764	2.950	0	91.374	-	-	Peak
2480	62.76	20	150	H	28.785	2.950	0	94.495	-	-	Peak
2480	56.38	132	168	V	28.764	2.950	0	88.094	-	-	Ave
2480	60.53	20	150	H	28.785	2.950	0	92.265	-	-	Ave
2483.5	31.05	132	168	V	29.764	2.950	0	63.764	74	-10.236	Peak
2483.5	33.63	20	150	H	28.785	2.950	0	65.365	74	-8.635	Peak
2483.5	18.91	132	168	V	28.764	2.950	0	50.624	54	-3.376	Ave
2483.5	21.85	20	150	H	28.785	2.950	0	53.585	54	-0.415	Ave
4960	46.11	0	150	V	33.531	4.404	35.909	48.136	74	-25.864	Peak
4960	48.19	315	150	H	33.556	4.404	35.909	50.241	74	-23.759	Peak
4960	30.83	0	150	V	33.531	4.404	35.909	32.856	54	-21.144	Ave
4960	34.88	315	150	H	33.556	4.404	35.909	36.931	54	-17.069	Ave
7440	45.3	0	150	V	37.242	5.869	35.963	52.448	74	-21.552	Peak
7440	45.36	0	150	H	37.238	5.869	35.963	52.504	74	-21.496	Peak
7440	30.65	0	150	V	37.242	5.869	35.963	37.798	54	-16.202	Ave
7440	30.61	0	150	H	37.238	5.869	35.963	37.754	54	-16.246	Ave
9920	45.96	0	150	V	39.036	7.657	35.976	56.677	71.374	-14.697	Peak
9920	46.03	0	150	H	39.052	7.657	35.976	56.763	74.495	-17.732	Peak
9920	31.36	0	150	V	39.036	7.657	35.976	42.077	68.094	-26.017	Ave
9920	30.87	0	150	H	39.052	7.657	35.976	41.603	72.265	-30.662	Ave

Note: Both the low channel and middle channel were tested with power setting 8, while the high channel was tested using power setting of 0.

7 FCC§15.247(a)(2) & IC RSS-210 §A8.2 – 6 dB & 99% Emission Bandwidth

7.1 Applicable Standards

According to FCC §15.247(a)(2) and IC RSS-210 A8.2 (a), systems using digital modulation techniques may operate in the 902~928 MHz, 2400~2483.5 MHz, and 5725~5850 MHz bands. The minimum 6 dB bandwidth shall be at least 500 kHz

7.2 Measurement Procedure

The measurements are based on FCC KDB 558074 D01 DTS Meas Guidance v03r02: Guidance for Performing Compliance Measurements on Digital Transmission Systems (DTS) Operating Under §15.247 section 8: DTS bandwidth

7.3 Test Equipment List and Details

Manufacturer	Description	Model No.	Serial No.	Calibration Date	Calibration Interval
Sunol Science Corp	System Controller	SC99V	122303-1	N/A	N/A
IW Microwave	Cable	SPS-2303-3840-SPS	DC1438	N/A	N/A
Agilent	Analyzer, Spectrum	E4440A	US 422221851	2014-04-09	1 year
EMCO	Antenna, Horn	3115	9511-4627	2015-01-15	1 year

Statement of Traceability: BACL attests that all calibrations have been performed per the A2LA requirements, traceable to NIST.

7.4 Test Environmental Conditions

Temperature:	17 °C
Relative Humidity:	46 %
ATM Pressure:	101.9 kPa

The testing was performed by Jerry Tong on 2015-03-10 in 5 m chamber 2.

7.5 Test Results

Channel	Frequency (MHz)	6 dB Emission Bandwidth (MHz)	99% Emission Bandwidth (MHz)	Limit (MHz)	Results
Low	2405	1.861	2.54	> 0.5	Compliant
Middle	2440	1.581	2.3975	> 0.5	Compliant
High	2480	1.584	2.3965	> 0.5	Compliant

Please refer to the following plots for detailed test results

Low channel: 2405 MHz

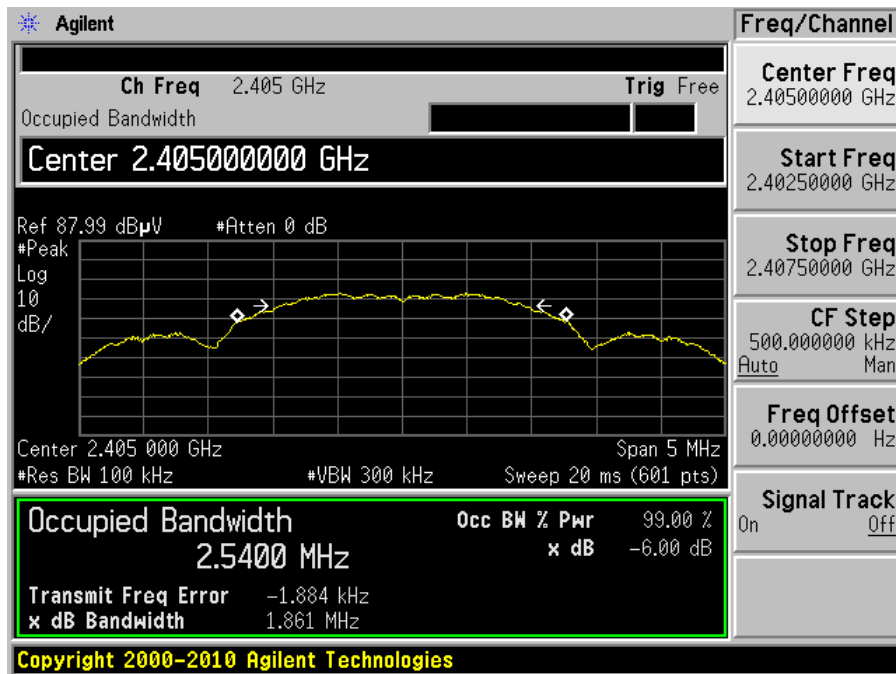

Middle channel: 2440 MHz

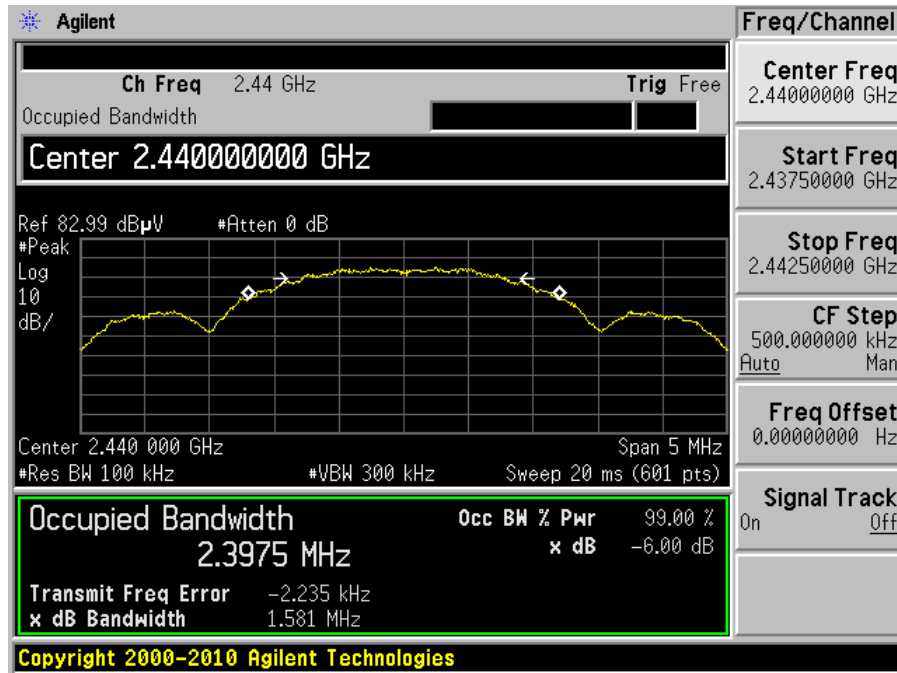

High Channel 2480 MHz

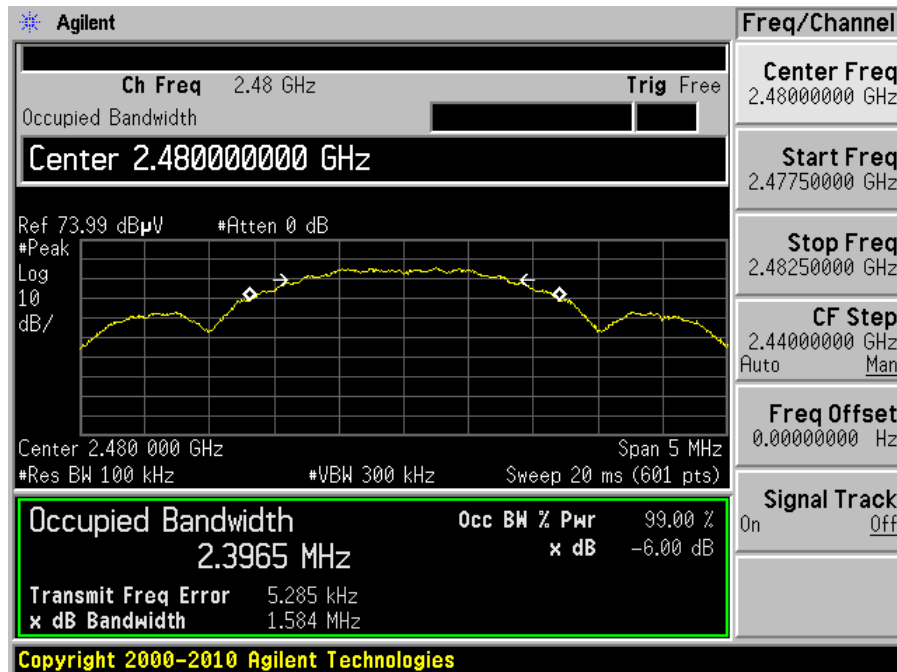

Note: These measurements were taken with the measuring antenna polarized horizontally.

8 FCC §15.247(b) & IC RSS-210 §A8.4 (4) – Peak Output Power Measurement

8.1 Applicable Standard

According to FCC §15.247(b) and IC RSS-210 §A8.4 (4) for systems using digital modulation in the 902~928 MHz, 2400~2483.5 MHz, and 5725~5850 MHz bands: 1 Watt.

8.2 Measurement Procedure

The measurements are base on FCC KDB 558074 D01 DTS Meas Guidance v03r02: Guidance for Performing Compliance Measurements on Digital Transmission Systems (DTS) Operating Under §15.247 section 9: Fundamental emission output power

8.3 Test Equipment List and Details

Manufacturer	Description	Model No.	Serial No.	Calibration Date	Calibration Interval
Sunol Science Corp	System Controller	SC99V	122303-1	N/A	N/A
IW Microwave	Cable	SPS-2303-3840-SPS	DC1438	N/A	N/A
Agilent	Analyzer, Spectrum	E4440A	US 422221851	2014-04-09	1 year
EMCO	Antenna, Horn	3115	9511-4627	2015-01-15	1 year

Statement of Traceability: BACL attests that all calibrations have been performed per the A2LA requirements, traceable to NIST.

8.4 Test Environmental Conditions

Temperature:	17 °C
Relative Humidity:	46 %
ATM Pressure:	101.9 kPa

The testing was performed by Jerry Tong on 2015-03-10 in 5 m chamber 2.

8.5 Test Results

Frequency (MHz)	S.A. Reading (dBμV)	Antenna Factor (dB/m)	Cable Loss (dB)	Cord. Reading (dBμV/m)	EIRP (dBm)	Antenna Gain (dBi)	Output Power (dBm)	Limit (dBm)	Power Setting
2405	72.5	28.383	-2.865	103.748	8.488	3.300	5.188	30	8
2440	71.28	28.383	-2.865	102.528	7.268	3.300	3.968	30	8
2480	62.89	28.764	-2.950	94.604	-0.656	3.300	-3.956	30	0

The field strength converts to conducted power should be as following:

$$E \text{ (dB}\mu\text{V/m)} = \text{EIRP [dBm]} + 95.26 \text{ for the distance at 3 meters.}$$

Please refer to the following plots:

Low channel: 2405 MHz

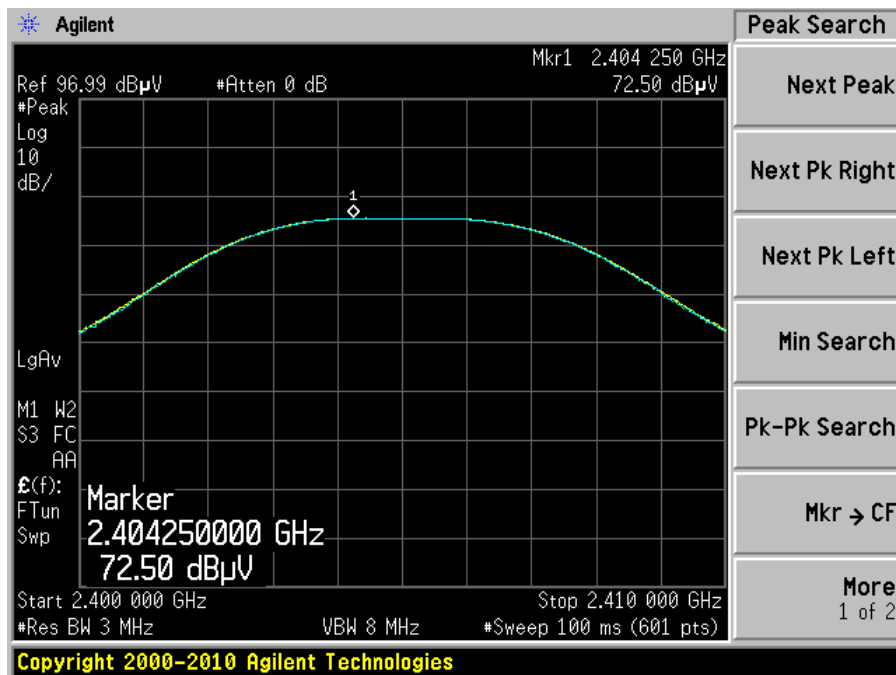

Middle channel: 2440 MHz

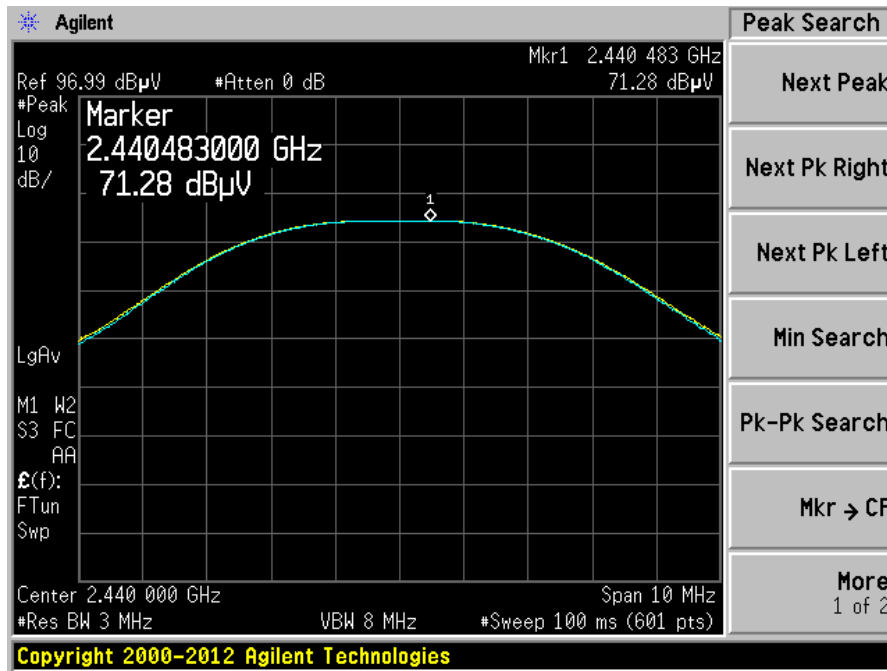

High Channel 2480 MHz

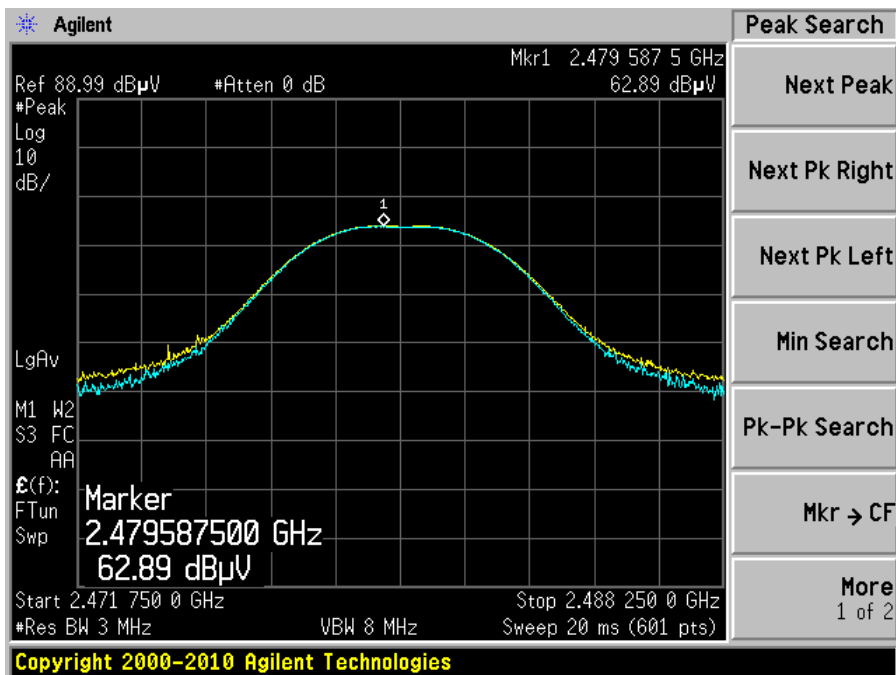

Note: These measurements were taken with the measuring antenna polarized horizontally.

9 FCC §15.247(d) & IC RSS-210 §A8.5 – 100 kHz Bandwidth of Band Edges

9.1 Applicable Standard

According to FCC §15.247(d), in any 100 kHz bandwidth outside the frequency bands in which the spread spectrum intentional radiator is operating, the radio frequency power that is produced by the intentional radiator shall be at least 20 dB below that in the 100 kHz bandwidth within the band that contains the highest level of the desired power, based on either an RF conducted or a radiated measurement. In addition, radiated emissions which fall in the restricted bands, as defined in §15.205(a), must also comply with the radiated emissions limits specified in §15.209(a) see §15.205(c).

According to IC Rss-210 §A8.5, in any 100 kHz bandwidth outside the frequency band in which the spread spectrum or digitally modulated device is operating, the radio frequency power that is produced shall be at least 20 dB below that in the 100 kHz bandwidth within the band that contains the highest level of the desired power, based on either an RF conducted or a radiated measurement, provided the transmitter demonstrates compliance with the peak conducted power limits. If the transmitter complies with the conducted power limits based on the use of RMS averaging over a time interval, as permitted under section A8.4(4), the attenuation required shall be 30 dB instead of 20 dB. Attenuation below the general limits specified in Tables 2 and 3 is not required.

9.2 Measurement Procedure

The measurements are based on FCC KDB 558074 D01 DTS Meas Guidance v03r01: Guidance for Performing Compliance Measurements on Digital Transmission Systems (DTS) Operating Under §15.247 section 13: Band-edge measurements

9.3 Test Equipment List and Details

Manufacturer	Description	Model No.	Serial No.	Calibration Date	Calibration Interval
Sunol Science Corp	System Controller	SC99V	122303-1	N/R	N/R
IW Microwave	Cable	SPS-2303-3840-SPS	DC1438	N/A	N/A
Agilent	Analyzer, Spectrum	E4440A	US 422221851	2014-04-09	1 year
EMCO	Antenna, Horn	3115	9511-4627	2015-01-15	1 year

Statement of Traceability: BACL attests that all calibrations have been performed per the A2LA requirements, traceable to NIST.

9.4 Test Environmental Conditions

Temperature:	17 °C
Relative Humidity:	46 %
ATM Pressure:	101.9 kPa

The testing was performed by Jerry Tong on 2015-03-10 in 5 m chamber 2.

9.5 Test Results

Please refer to following plots of the band edge.

Low Channel 2405 MHz

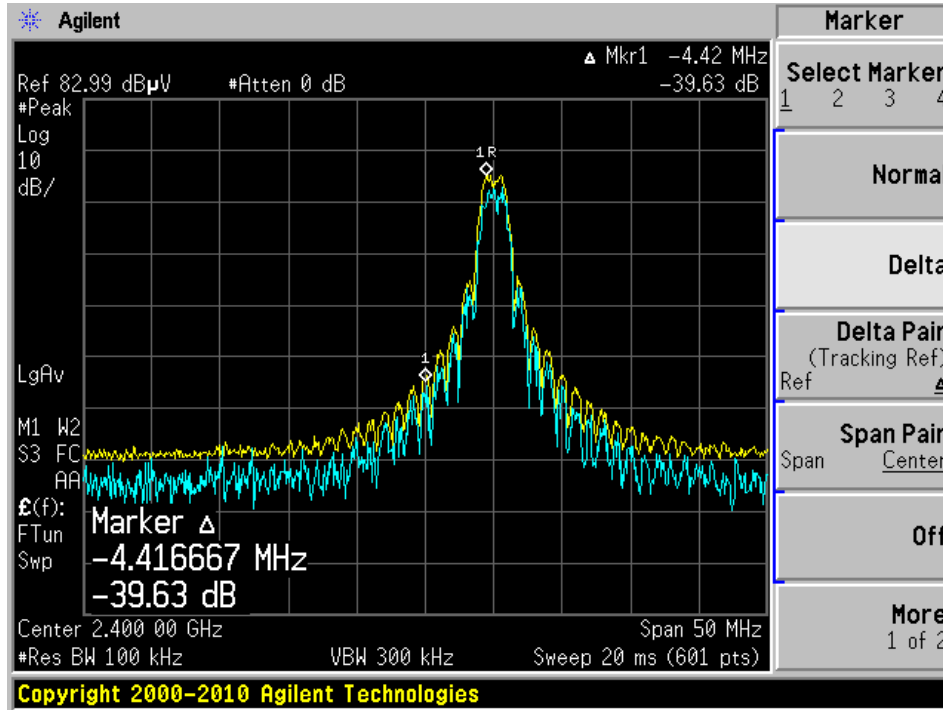

High Channel 2480 MHz

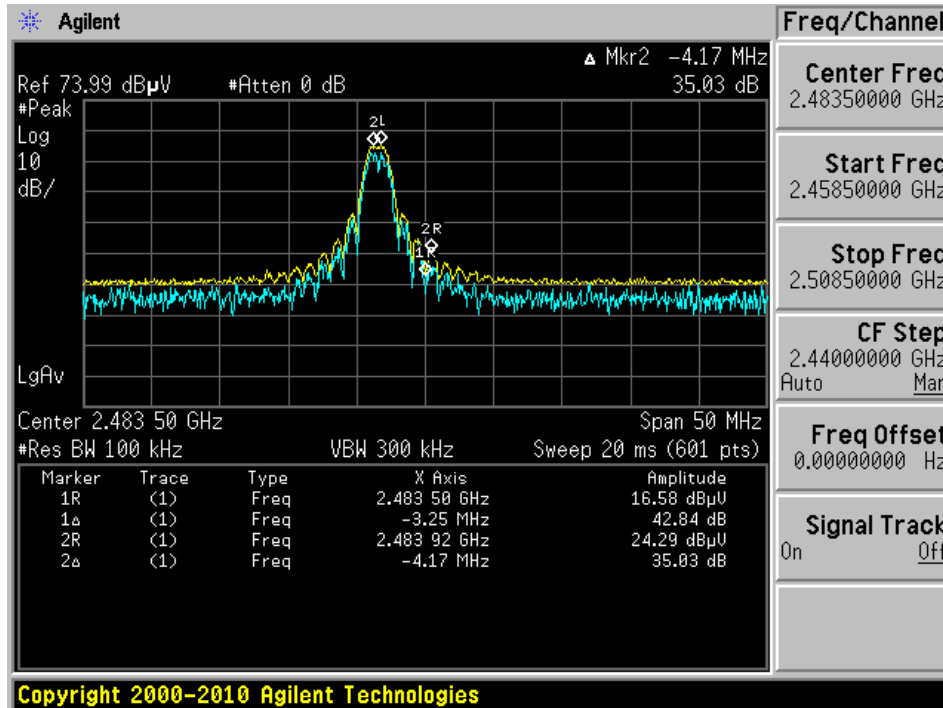

10 FCC §15.247(e) & IC RSS-210 §A8.2 (b) – Power Spectral Density

10.1 Applicable Standard

According to FCC §15.247(e) and RSS-210 §A8.2 (b), for digitally modulated systems, the power spectral density conducted from the intentional radiator to the antenna shall not be greater than 8 dBm in any 3 kHz band during any time interval of continuous transmission.

10.2 Measurement Procedure

The measurements are based on FCC KDB 558074 D01 DTS Meas Guidance v03r01: Guidance for Performing Compliance Measurements on Digital Transmission Systems (DTS) Operating Under §15.247 section 10: Maximum power spectral density level in the fundamental emission

10.3 Test Equipment List and Details

Manufacturer	Description	Model No.	Serial No.	Calibration Date	Calibration Interval
Sunol Science Corp	System Controller	SC99V	122303-1	N/R	N/R
IW Microwave	Cable	SPS-2303-3840-SPS	DC1438	N/A	N/A
Agilent	Analyzer, Spectrum	E4440A	US 422221851	2014-04-09	1 year
EMCO	Antenna, Horn	3115	9511-4627	2015-01-15	1 year

Statement of Traceability: BACL attests that all calibrations have been performed per the A2LA requirements, traceable to NIST.

10.4 Test Environmental Conditions

Temperature:	17 °C
Relative Humidity:	46 %
ATM Pressure:	101.9 kPa

The testing was performed by Jerry Tong on 2015-03-10 in 5 m chamber 2.

10.5 Test Results

Frequency (MHz)	S.A. Reading (dBμV)	Antenna Factor (dB/m)	Cable Loss (dB)	Cord. Reading (dBμV/m)	EIRP (dBm)	Antenna Gain (dBi)	Output Power (dBm)	Limit
2405	56.87	28.383	-2.865	88.118	-7.142	3.3	-10.442	8
2440	55.4	28.383	-2.865	86.648	-8.612	3.3	-11.912	8
2480	46.2	28.764	-2.950	77.914	-17.346	3.3	-20.646	8

The field strength converts to conducted power should be as following:

$$E \text{ (dB}\mu\text{V/m)} = \text{EIRP [dBm]} + 95.26 \text{ for the distance at 3 meters.}$$

Please refer to the following plots for detailed test results:

Low channel: 2405 MHz

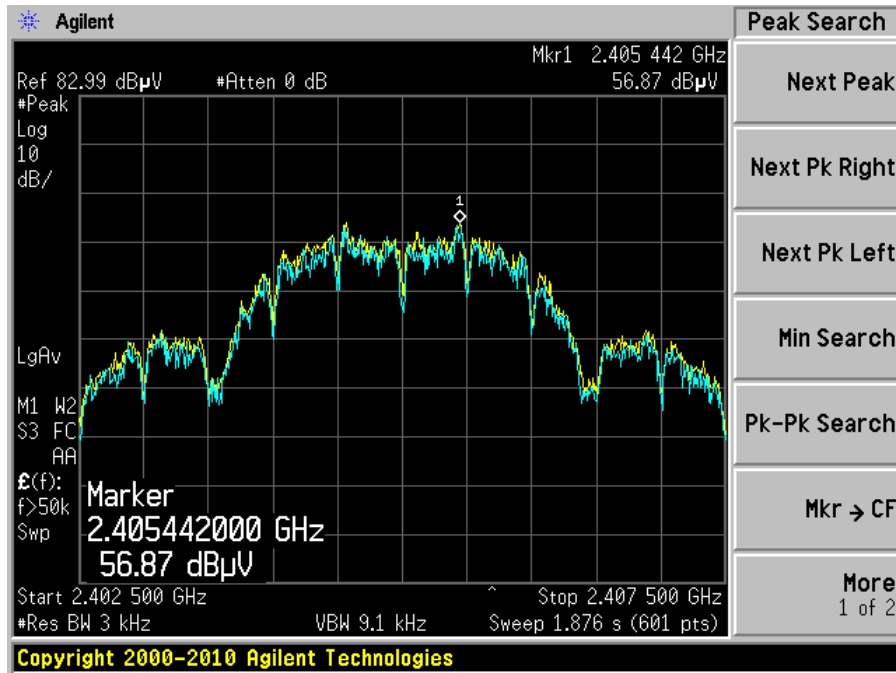

Middle channel: 2440 MHz

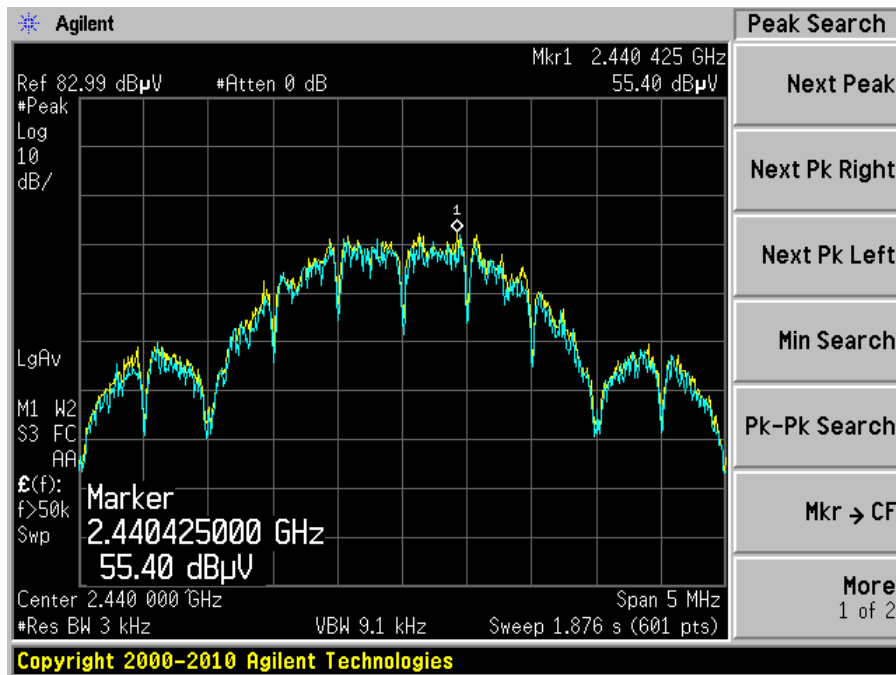

High Channel 2480 MHz

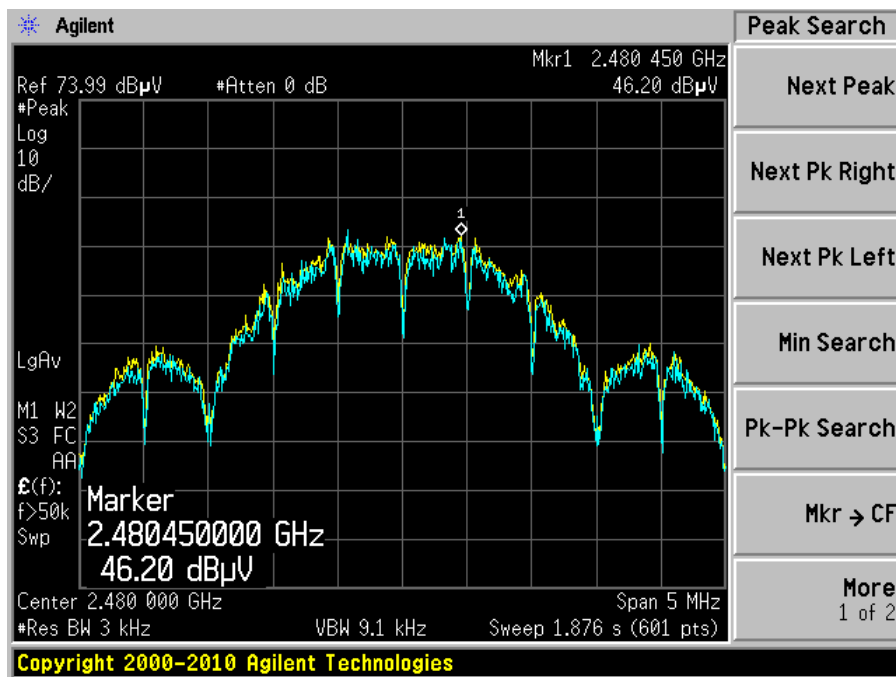

Note: These measurements were taken with the measuring antenna polarized horizontally.