



## FCC TEST REPORT

### 47 CFR FCC Part 15 Subpart B

FCC ID .....	T37PL9671-A2	
Report Reference No. ....	TRE10080050	
Compiled by ( position+printed name+signature) ..:	File administrators Wenliang Li	<i>Wenliang Li</i>
Supervised by ( position+printed name+signature) ..:	Test Engineer Xiankun Ding	<i>Xiankun Ding</i>
Approved by ( position+printed name+signature) ..:	Manager Jimmy Li	<i>Jimmy Li</i>
Date of issue .....	Oct 28, 2010	
Testing Laboratory Name .....	<b>Shenzhen Huatongwei International Inspection Co., Ltd</b>	
Address .....	Keji Nan No.12 Road, Hi-tech Park, Shenzhen, China	
Applicant's name .....	<b>ASOKA USA Corporation</b>	
Address .....	2344-A Walsh Avenue, Santa Clara City, CA 95051	
<b>Test specification:</b>		
Standard .....	<b>47 CFR FCC Part 15 Subpart B - Unintentional Radiators</b> <b>ANSI C63.4: 2009</b>	
TRF Originator .....	Shenzhen Huatongwei International Inspection CO., Ltd	
Master TRF .....	Dated 2006-06	
<b>Shenzhen Huatongwei International Inspection Co., Ltd. All rights reserved.</b>		
This publication may be reproduced in whole or in part for non-commercial purposes as long as the Shenzhen Huatongwei International Inspection Co., Ltd is acknowledged as copyright owner and source of the material. Shenzhen Huatongwei International Inspection Co., Ltd takes no responsibility for and will not assume liability for damages resulting from the reader's interpretation of the reproduced material due to its placement and context.		
Test item description .....	Pluglink-ETH-500	
Trade Mark .....	/	
Model/Type reference .....	PL9671-A2	
Listed Models .....	/	
Result .....	<b>Positive</b>	

**TEST REPORT**

<b>Test Report No. :</b>	<b>TRE10080050</b>	Oct 28, 2010
		Date of issue

Equipment under Test : Pluglink-ETH-500

Model /Type : PL9671-A2

Listed Models : /

Applicant : ASOKA USA Corporation

Address : 2344-A Walsh Avenue, Santa Clara City, CA 95051

Manufacturer : Asoka USA Corporation

Address : 2344-A Walsh Avenue Santa Clara City, CA 95051

<b>Test Result</b> according to the standards on page 4:	<b>Positive</b>
----------------------------------------------------------	-----------------

The test report merely corresponds to the test sample.  
It is not permitted to copy extracts of these test result without the written permission of the test laboratory.

# Contents

- 1. TEST STANDARDS ..... 4**
  
- 2. SUMMARY ..... 5**
  - 2.1. General Remarks 5
  - 2.2. Equipment Under Test 5
  - 2.3. Short description of the Equipment under Test (EUT) 5
  - 2.4. EUT operation mode 5
  - 2.5. Related Submittal(s) / Grant (s) 5
  - 2.6. Modifications 5
  - 2.7. Configuration of Tested System 6
  
- 3. TEST ENVIRONMENT ..... 7**
  - 3.1. Address of the test laboratory 7
  - 3.2. Test Facility 7
  - 3.3. Environmental conditions 8
  - 3.4. Statement of the measurement uncertainty 8
  - 3.5. Equipments Used during the Test 9
  
- 4. TEST CONDITIONS AND RESULTS ..... 10**
  - 4.1. Conducted Emissions Test 10
  - 4.2. Radiated Emission Test 16
  
- 5. TEST SETUP PHOTOS OF THE EUT ..... 22**
  
- 6. EXTERNAL AND INTERNAL PHOTOS OF THE EUT ..... 24**

## 1. TEST STANDARDS

The tests were performed according to following standards:

[47 CFR FCC Part 15 Subpart B](#) - Unintentional Radiators

[ANSI C63.4: 2009](#) – American National Standard for Methods of Measurement of Radio-Noise Emissions from Low-Voltage Electrical and Electronic Equipment in the Range of 9 kHz to 40GHz

## 2. SUMMARY

### 2.1. General Remarks

Date of receipt of test sample : Sep 01, 2010

Testing commenced on : Sep 01, 2010

Testing concluded on : Oct 26, 2010

### 2.2. Equipment Under Test

#### Power supply system utilised

Power supply voltage :  120V / 60 Hz  115V / 60Hz  
 12 V DC  24 V DC  
 Other (specified in blank below)

/

### 2.3. Short description of the Equipment under Test (EUT)

The EUT Pluglink-ETH-500 is an In-House BPL device.

For more details, refer to the user's manual of the EUT.

Sample Type: Prototype

### 2.4. EUT operation mode

The EUT has been tested under typical operating condition.

### 2.5. Related Submittal(s) / Grant (s)

This submittal(s) (test report) is intended for FCC ID: **T37PL9671-A2** filing to comply with the FCC Part 15, Subpart B Rules.

### 2.6. Modifications

No modifications were implemented to meet testing criteria.

## 2.7. Configuration of Tested System

Configuration of Tested System

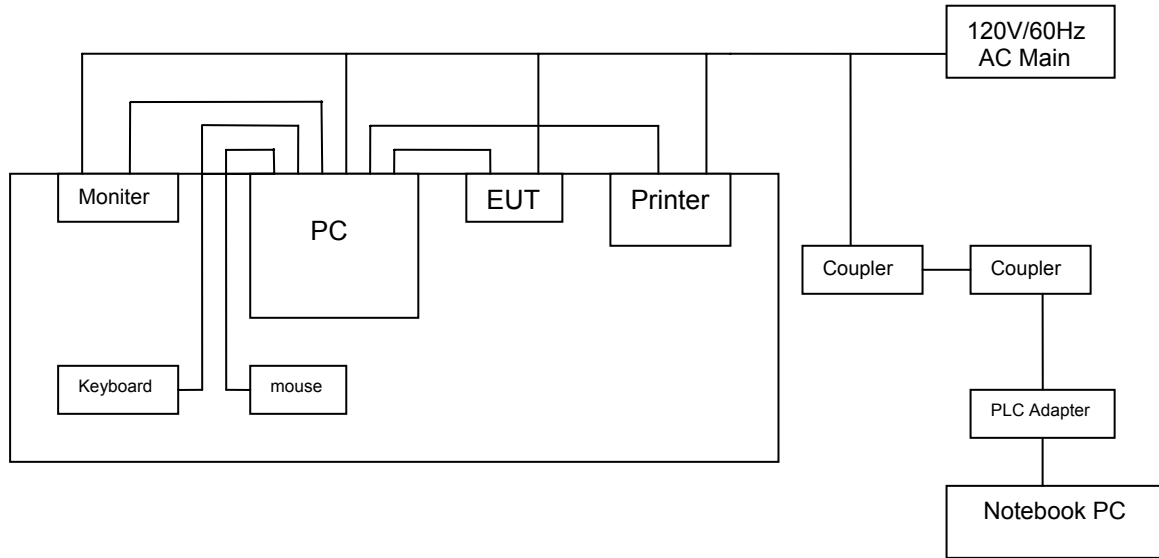

Equipment Used in Tested System

No.	Equipment	Manufacturer	Model No.	Serial No.	Notes
1	PC	HP	Compaq dx2310MT	CNG8390Q6X	(1)
2	Monitor	DELL	1707FPt	CN-OFC237-71618-65G-AAKC	(1)
3	Notebook PC	DELL	PP01L	2F485A00	(1)
4	Printer	HP	Laserjet 6L C3990A	JPZP024664	(1)
5	Keyboard	DELL	L100	CNRH65665890726009L	(1)
6	Mouse	DELL	MO56UOA	G0E02SY7	(1)
7	PlugLink AV 9560 Wireless Adapter	ASOKA	PL9560-WAP	/	(2)
8	Coupler	ASOKA	/	/	(2)

Note: (1) - supplied by test lab.  
 (2) - supplied by manufacturer.

### **3. TEST ENVIRONMENT**

#### **3.1. Address of the test laboratory**

Shenzhen Huatongwei International Inspection Co., Ltd  
Keji Nan No.12 Road, Hi-tech Park, Shenzhen, China  
Phone: 86-755-26715686 Fax: 86-755-26748089

The sites are constructed in conformance with the requirements of ANSI C63.7, ANSI C63.4 (2003) and CISPR Publication 22.

#### **3.2. Test Facility**

The test facility is recognized, certified, or accredited by the following organizations:

##### **CNAS-Lab Code: L1225**

Shenzhen Huatongwei International Inspection Co., Ltd has been assessed and proved to be in compliance with CNAS-CL01 Accreditation Criteria for Testing and Calibration Laboratories (identical to ISO/IEC 17025: 2005 General Requirements) for the Competence of Testing and Calibration Laboratories, Date of Registration: Mar 30, 2009. Valid time is until Mar 29, 2012.

##### **A2LA-Lab Cert. No. 2243.01**

Shenzhen Huatongwei International Inspection Co., Ltd, EMC Laboratory has been accredited by A2LA for technical competence in the field of electrical testing, and proved to be in compliance with ISO/IEC 17025: 2005 General Requirements for the Competence of Testing and Calibration Laboratories and any additional program requirements in the identified field of testing. Valid time is until Sept 30, 2011.

##### **FCC-Registration No.: 662850**

Shenzhen Huatongwei International Inspection Co., Ltd, EMC Laboratory has been registered and fully described in a report filed with the FCC (Federal Communications Commission). The acceptance letter from the FCC is maintained in our files. Registration 662850, Renewal date Jun 01, 2009.

##### **IC-Registration No.: 5377**

The 3m Alternate Test Site of Shenzhen Huatongwei International Inspection Co., Ltd has been registered by Certification and Engineering Bureau of Industry Canada for the performance of radiated measurements with Registration No. 5377 on November Feb 13, 2009. Valid time is until Feb 13, 2011.

##### **ACA**

Shenzhen Huatongwei International Inspection Co., Ltd, EMC Laboratory can also perform testing for the Australian C-Tick mark as a result of our A2LA accreditation.

##### **NEMKO-Aut. No.: ELA125**

Shenzhen Huatongwei International Inspection Co., Ltd has been assessed the quality assurance system, the testing facilities, qualifications and testing practices of the relevant parts of the organization. The quality assurance system of the Laboratory has been validated against ISO/IEC 17025:2005 or equivalent. The laboratory also fulfils the conditions described in Nemko Document NLA-10, the Authorization is valid through July 07, 2011.

##### **VCCI**

The 3m Semi-anechoic chamber (12.2m×7.95m×6.7m) and Shielded Room (8m×4m×3m) of Shenzhen Huatongwei International Inspection Co., Ltd has been registered in accordance with the Regulations for Voluntary Control Measures with Registration No.: R-2484. Date of Registration: December 20, 2006. Valid time is until December 20, 2012.

Main Ports Conducted Interference Measurement of Shenzhen Huatongwei International Inspection Co., Ltd has been registered in accordance with the Regulations for Voluntary Control Measures with Registration No.: C-2726. Date of Registration: December 20, 2006. Valid time is until December 19, 2012.

## DNV

Shenzhen Huatongwei International Inspection Co Ltd has been found to comply with the requirements of DNV towards subcontractor of EMC and safety testing services in conjunction with the EMC and Low voltage Directives and in the voluntary field. The acceptance is based on a formal quality Audit and follow-ups according to relevant parts of ISO/IEC Guide 17025(2005), in accordance with the requirements of the DNV Laboratory Quality Manual towards subcontractors. Valid time is until Aug 24, 2013.

### 3.3. Environmental conditions

During the measurement the environmental conditions were within the listed ranges:

Temperature:	<u>15-35 ° C</u>
Humidity:	<u>30-60 %</u>
Atmospheric pressure:	<u>950-1050mbar</u>

### 3.4. Statement of the measurement uncertainty

The data and results referenced in this document are true and accurate. The reader is cautioned that there may be errors within the calibration limits of the equipment and facilities. The measurement uncertainty was calculated for all measurements listed in this test report acc. to CISPR 16 - 4 „Specification for radio disturbance and immunity measuring apparatus and methods – Part 4: Uncertainty in EMC Measurements“ and is documented in the Shenzhen Huatongwei International Inspection Co., Ltd quality system acc. to DIN EN ISO/IEC 17025. Furthermore, component and process variability of devices similar to that tested may result in additional deviation. The manufacturer has the sole responsibility of continued compliance of the device.

Hereafter the best measurement capability for Shenzhen Huatongwei laboratory is reported:

Test	Range	Measurement Uncertainty	Notes
Radiated Emission	30~1000MHz	4.22dB	(1)
Radiated Emission	1~12.75GHz	4.35dB	(1)
Conducted Disturbance	0.15~30MHz	3.29dB	(1)

- (1) This uncertainty represents an expanded uncertainty expressed at approximately the 95% confidence level using a coverage factor of k=2.



### 3.5. Equipments Used during the Test

Conducted Emission					
Item	Test Equipment	Manufacturer	Model No.	Serial No.	Last Cal.
1	EMI TEST RECEIVER	ROHDE & SCHWARZ	ESCI	100106	2009/11
2	ARTIFICIAL MAINS	ROHDE & SCHWARZ	ESH2-Z5	100028	2009/11
3	PULSE LIMITER	ROHDE & SCHWARZ	ESHSZ2	100044	2009/11
4	EMI TEST SOFTWARE	ROHDE & SCHWARZ	ES-K1	N/A	2009/11
5	TWO-LINE V-NETWORK	ROHDE & SCHWARZ	ESH3-Z5	100049	2009/11

Radiated Emissions					
Item	Test Equipment	Manufacturer	Model No.	Serial No.	Last Cal.
1	ULTRA-BROADBAND ANTENNA	ROHDE & SCHWARZ	HL562	100015	2010/05
2	Amplifier	Sonoma	310 N	291722	2009/11
3	Double-Ridged-Waveguide Horn Antenna	ROHDE & SCHWARZ	HF906	100039	2009/11
4	Amplifier	ROHDE & SCHWARZ	HF906 (1-18)GMZ	00101800-28-5A	2009/11
5	EMI TEST RECEIVER	ROHDE & SCHWARZ	ESI 26	100009	2009/11
6	RF TEST PANEL	ROHDE & SCHWARZ	TS / RSP	335015/ 0017	2009/11
7	TURNTABLE	ETS	2088	2149	2009/11
8	ANTENNA MAST	ETS	2075	2346	2009/11
9	EMI TEST SOFTWARE	ROHDE & SCHWARZ	ESK1	N/A	2009/11

## **4. TEST CONDITIONS AND RESULTS**

### **4.1. Conducted Emissions Test**

#### **TEST CONFIGURATION**

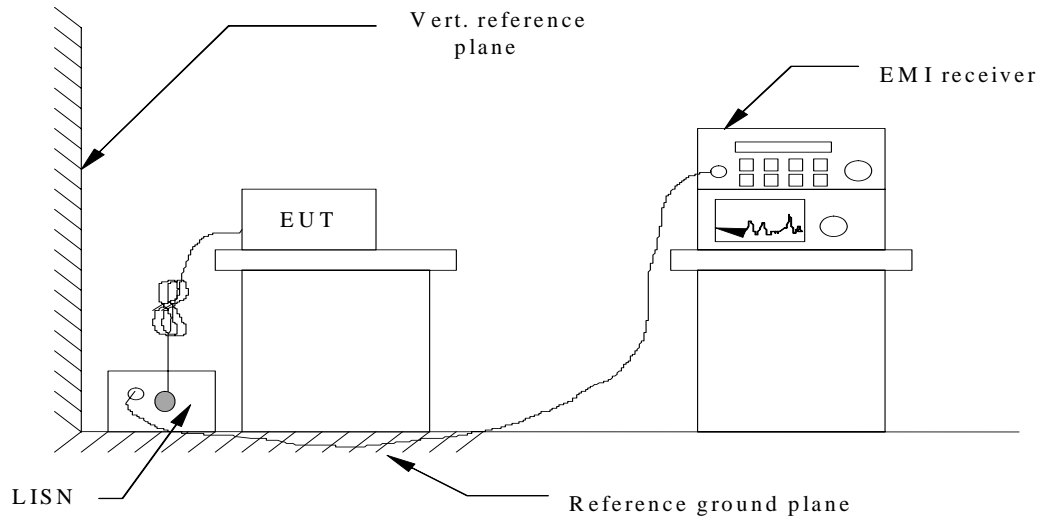

#### **TEST PROCEDURE**

- 1 The equipment was set up as per the test configuration to simulate typical actual usage per the user's manual. The EUT is a tabletop system, a wooden table with a height of 0.8 meters is used and is placed on the ground plane as per ANSI C63.4-2009.
- 2 Support equipment, if needed, was placed as per ANSI C63.4-2009.
- 3 All I/O cables were positioned to simulate typical actual usage as per ANSI C63.4-2009.
- 4 The EUT received AC120V/60Hz power through a Line Impedance Stabilization Network (LISN) which supplied power source and was grounded to the ground plane.
- 5 All support equipments received AC power from a second LISN, if any.
- 6 The EUT test program was started. Emissions were measured on each current carrying line of the EUT using a spectrum Analyzer / Receiver connected to the LISN powering the EUT. The LISN has two monitoring points: Line 1 (Hot Side) and Line 2 (Neutral Side). Two scans were taken: one with Line 1 connected to Analyzer / Receiver and Line 2 connected to a 50 ohm load; the second scan had Line 1 connected to a 50 ohm load and Line 2 connected to the Analyzer / Receiver.
- 7 Analyzer / Receiver scanned from 150 KHz to 30MHz for emissions in each of the test modes.
- 8 During the above scans, the emissions were maximized by cable manipulation.

**CONDUCTED POWER LINE EMISSION LIMIT**

For unintentional device, according to § 15.107(a) Line Conducted Emission Limits is as following :

Frequency (MHz)	Maximum RF Line Voltage (dB $\mu$ V)			
	CLASS A		CLASS B	
	Q.P.	Ave.	Q.P.	Ave.
0.15 - 0.50	79	66	66-56*	56-46*
0.50 - 5.00	73	60	56	46
5.00 - 30.0	73	60	60	50

For unintentional device, according to § 15.107(c) Line Conducted Emission Limits is as following :

Frequency (KHz)	Maximum RF Line Voltage	
	Q.P.	Ave.
535-1705	1000 $\mu$ V	60dB $\mu$ V

For In-House BPL devices operating as unintentional radiators below 30 MHz, the conducted emissions shall be measured in the 535 – 1705 kHz band as specified in Section 15.107(c). For In- House BPL devices operating as unintentional radiators above 30 MHz, the conducted emissions shall be measured as specified in Section 15.107(a).

**TEST CONDITION**

The data rate was set at the maximum rate used by the EUT, and the operating frequency of the EUT as unintentional radiator was divided into two frequency band, below 30MHz and above 30MHz.

**TEST RESULTS**

Operating frequency blow 30MHz

SCAN TABLE: "Voltage (9K-30M)FIN"

Short Description: 150K-30M Voltage

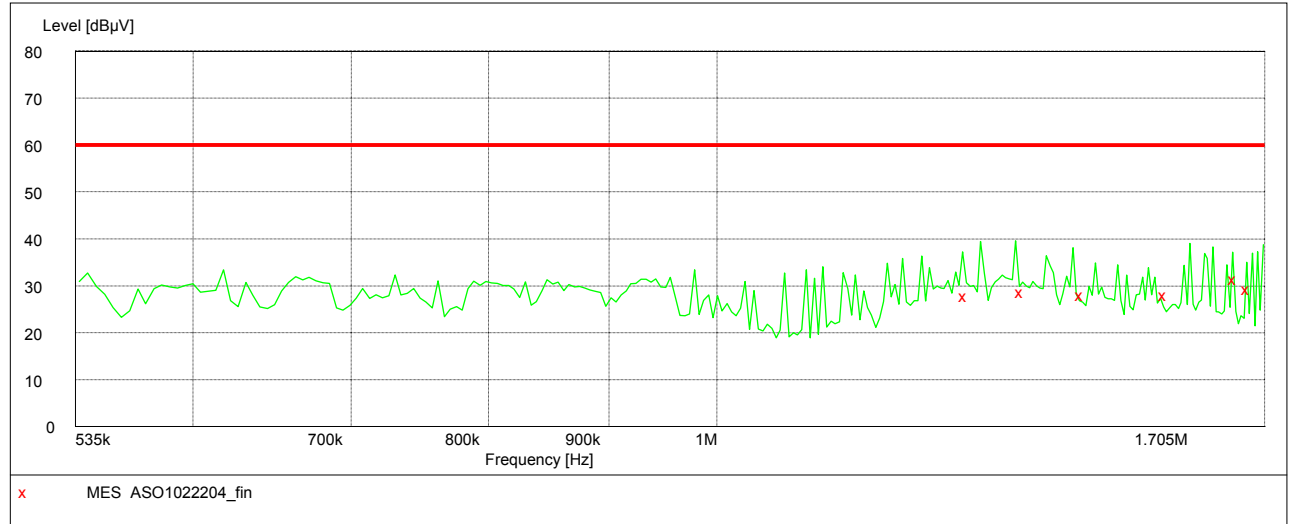

**MEASUREMENT RESULT: "ASO1022204\_fin"**

10/22/2010 3:18PM

Frequency MHz	Level dBµV	Transd dB	Limit dBµV	Margin dB	Detector	Line	PE
1.275000	28.10	10.2	60	31.9	QP	L1	GND
1.347000	28.90	10.2	60	31.1	QP	L1	GND
1.428000	28.30	10.2	60	31.7	QP	L1	GND
1.549500	28.20	10.2	60	31.8	QP	L1	GND
1.657500	31.70	10.2	60	28.3	QP	L1	GND
1.680000	29.60	10.2	60	30.4	QP	L1	GND

**Remark:**

- (1) Measuring frequencies from 0.535 MHz to the 1.705 MHz.
- (2) Data of measurement within this frequency range shown "---" in the table above means the reading of emissions are attenuated more than 20dB below the permissible limits or the field strength is too small to be measured.
- (3) The IF bandwidth of EMI Test Receiver was 9KHz for measuring from 0.535 MHz to 1.705 MHz

**SCAN TABLE: "Voltage (9K-30M)FIN"**

Short Description: 150K-30M Voltage

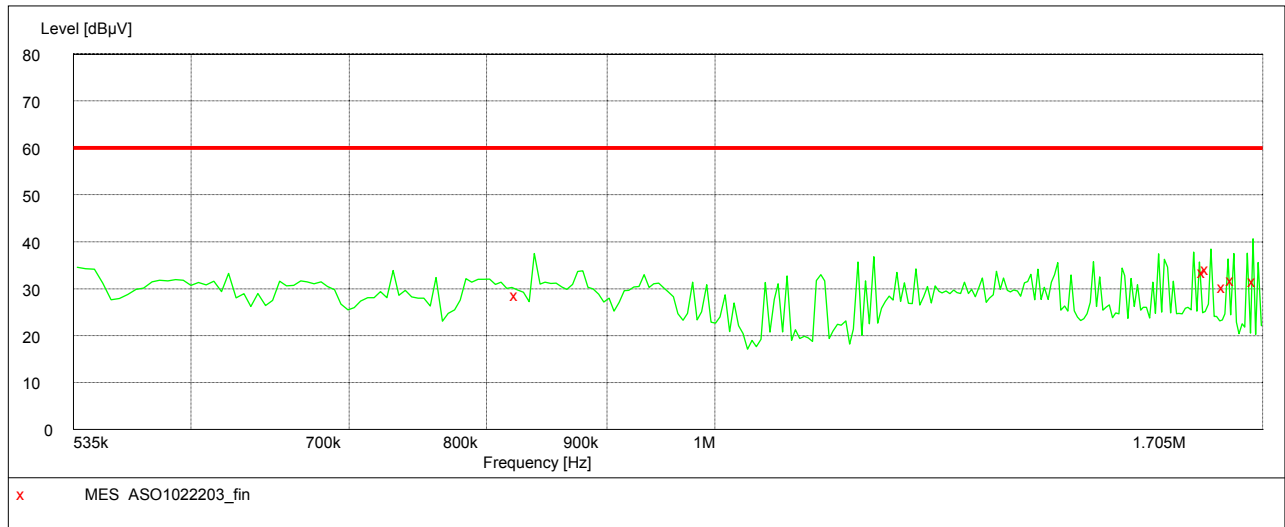

**MEASUREMENT RESULT: "ASO1022203\_fin"**

10/22/2010 3:14PM

Frequency MHz	Level dBµV	Transd dB	Limit dBµV	Margin dB	Detector	Line	PE
0.825000	28.80	10.2	60	31.2	QP	N	GND
1.612500	33.70	10.2	60	26.3	QP	N	GND
1.617000	34.40	10.2	60	25.6	QP	N	GND
1.644000	30.60	10.2	60	29.4	QP	N	GND
1.657500	31.90	10.2	60	28.1	QP	N	GND
1.693500	31.70	10.2	60	28.3	QP	N	GND

**Remark:**

- (1) Measuring frequencies from 0.535 MHz to the 1.705 MHz.
- (2) Data of measurement within this frequency range shown "---" in the table above means the reading of emissions are attenuated more than 20dB below the permissible limits or the field strength is too small to be measured.
- (3) The IF bandwidth of EMI Test Receiver was 9KHz for measuring from 0.535 MHz to 1.705 MHz

**Operating frequency above 30MHz**

**SCAN TABLE: "Voltage (9K-30M)FIN"**

Short Description: 150K-30M Voltage

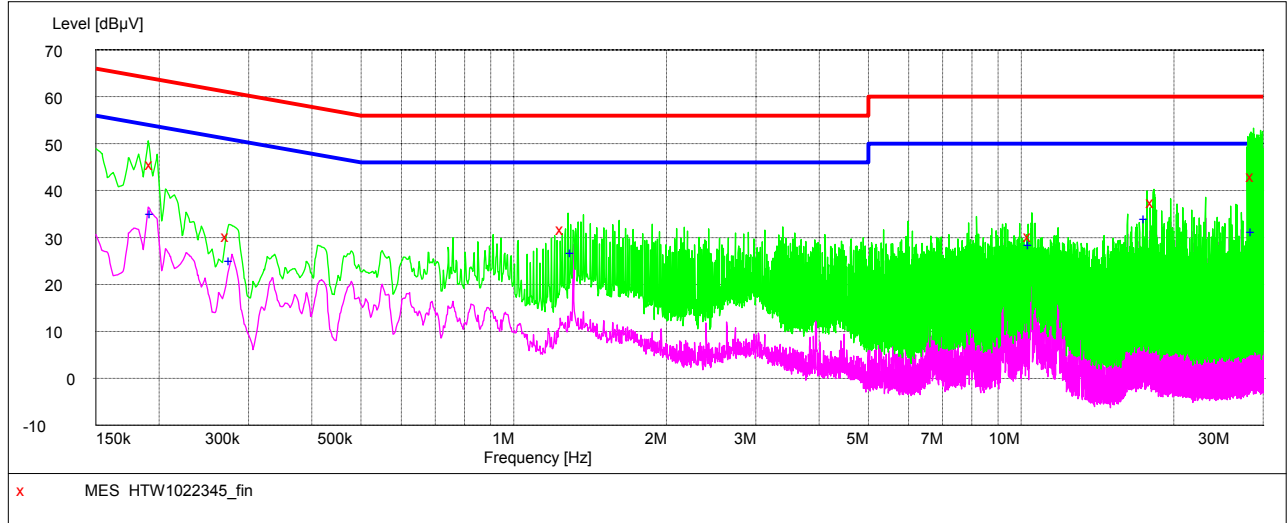

**MEASUREMENT RESULT: "HTW1022345\_fin"**

10/22/2010 4:17PM

Frequency MHz	Level dBµV	Transd dB	Limit dBµV	Margin dB	Detector	Line	PE
0.194000	45.90	10.5	64	18.0	QP	L1	GND
0.274000	30.50	10.5	61	30.5	QP	L1	GND
1.254000	32.00	10.5	56	24.0	QP	L1	GND
10.462000	30.50	10.9	60	29.5	QP	L1	GND
18.246000	37.70	11.0	60	22.3	QP	L1	GND
28.714000	43.40	11.3	60	16.6	QP	L1	GND

**MEASUREMENT RESULT: "HTW1022345\_fin2"**

10/22/2010 4:14PM

Frequency MHz	Level dBµV	Transd dB	Limit dBµV	Margin dB	Detector	Line	PE
0.194000	35.10	10.5	54	18.8	AV	L1	GND
0.278000	25.10	10.5	51	25.8	AV	L1	GND
1.310000	26.90	10.5	46	19.1	AV	L1	GND
10.466000	28.60	10.9	50	21.4	AV	L1	GND
17.694000	34.10	11.0	50	15.9	AV	L1	GND
28.686000	31.30	11.3	50	18.7	AV	L1	GND

**Remark:**

- (1) Measuring frequencies from 0.15 MHz to the 30 MHz.
- (2) Data of measurement within this frequency range shown "---" in the table above means the reading of emissions are attenuated more than 20dB below the permissible limits or the field strength is too small to be measured.
- (3) The IF bandwidth of EMI Test Receiver was 9KHz for measuring from 0.15 MHz to 30MHz

**SCAN TABLE: "Voltage (9K-30M)FIN"**

Short Description: 150K-30M Voltage

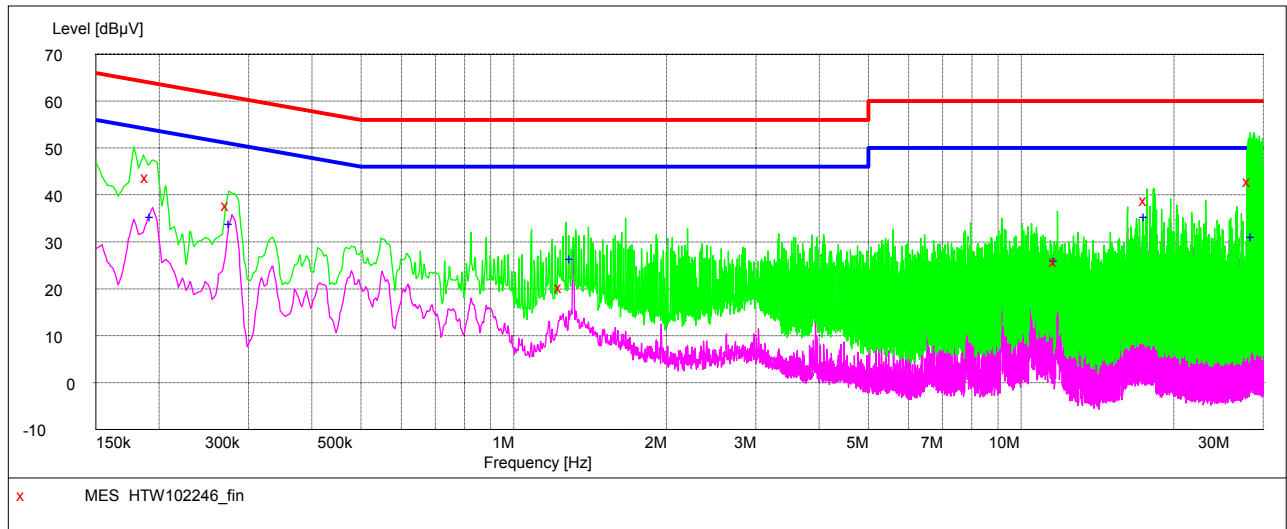

**MEASUREMENT RESULT: "HTW1022346\_fin"**

10/22/2010 4:17PM

Frequency MHz	Level dBµV	Transd dB	Limit dBµV	Margin dB	Detector	Line	PE
0.190000	43.90	10.5	64	20.1	QP	N	GND
0.274000	38.10	10.5	61	22.9	QP	N	GND
1.242000	20.60	10.5	56	35.4	QP	N	GND
11.762000	26.00	10.9	60	34.0	QP	N	GND
17.694000	39.20	11.0	60	20.8	QP	N	GND
28.346000	43.10	11.3	60	16.9	QP	N	GND

**MEASUREMENT RESULT: "HTW1022346\_fin2"**

10/22/2010 4:17PM

Frequency MHz	Level dBµV	Transd dB	Limit dBµV	Margin dB	Detector	Line	PE
0.194000	35.40	10.5	54	18.5	AV	N	GND
0.278000	34.00	10.5	51	16.9	AV	N	GND
1.306000	26.60	10.5	46	19.4	AV	N	GND
11.770000	26.10	10.9	50	23.9	AV	N	GND
17.694000	35.40	11.0	50	14.6	AV	N	GND
28.686000	31.10	11.3	50	18.9	AV	N	GND

**Remark:**

- (1) Measuring frequencies from 0.15 MHz to the 30 MHz.
- (2) Data of measurement within this frequency range shown "---" in the table above means the reading of emissions are attenuated more than 20dB below the permissible limits or the field strength is too small to be measured.
- (3) The IF bandwidth of EMI Test Receiver was 9KHz for measuring from 0.15 MHz to 30MHz

## 4.2. Radiated Emission Test

### TEST CONFIGURATION

- a) Radiated Emission Test Set-Up, Frequency below 1000MHz

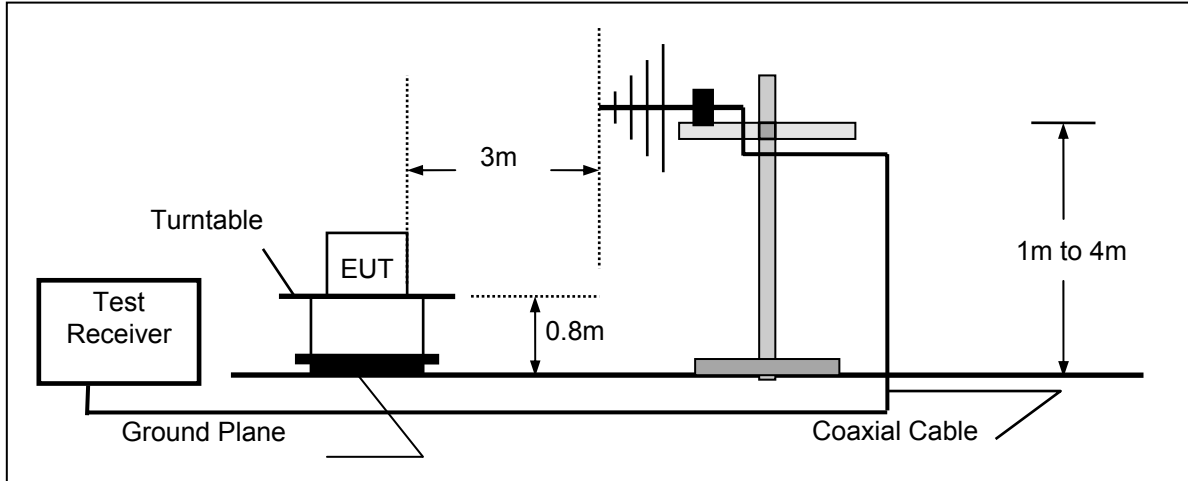

- b) Radiated Emission Test Set-Up, Frequency above 1000MHz

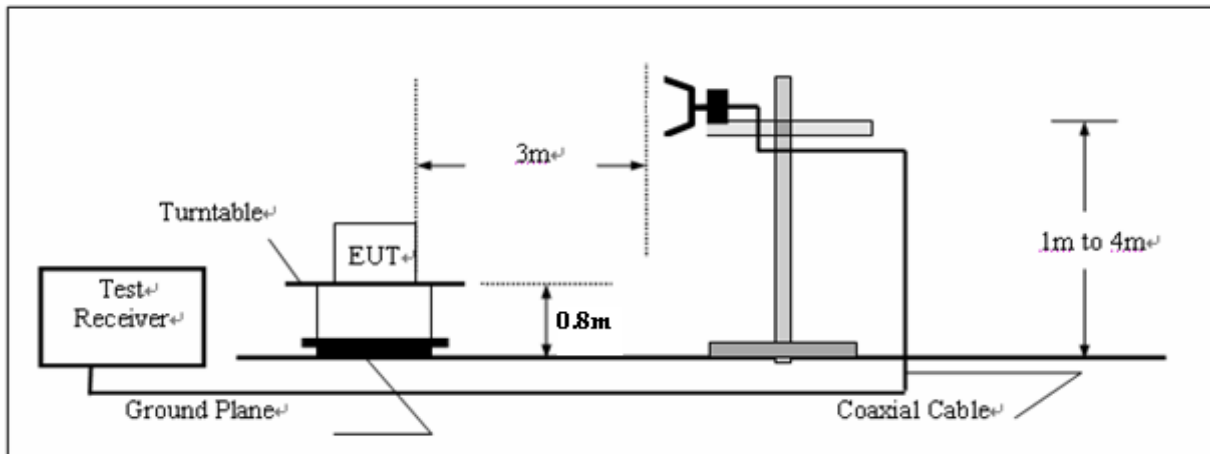

### TEST PROCEDURE

1. The EUT is placed on a turntable, which is 0.8m above ground plane.
2. The turntable shall be rotated for 360 degrees to determine the position of maximum emission level.
3. EUT is set 3m away from the receiving antenna, which is varied from 1m to 4m to find out the highest emissions.
4. Maximum procedure was performed on the six highest emissions to ensure EUT compliance.
5. And also, each emission was to be maximized by changing the polarization of receiving antenna both horizontal and vertical.
6. Repeat above procedures until the measurements for all frequencies are complete.



**FIELD STRENGTH CALCULATION**

The field strength is calculated by adding the Antenna Factor and Cable Factor and subtracting the Amplifier Gain and Duty Cycle Correction Factor (if any) from the measured reading. The basic equation with a sample calculation is as follows:

$$FS = RA + AF + CL - AG$$

Where FS = Field Strength	CL = Cable Attenuation Factor (Cable Loss)
RA = Reading Amplitude	AG = Amplifier Gain
AF = Antenna Factor	

**RADIATION LIMIT**

For unintentional device, according to § 15.109(a), except for Class A digital devices, the field strength of radiated emissions from unintentional radiators at a distance of 3 meters shall not exceed the following values:

Frequency (MHz)	Distance (Meters)	Radiated (dBμV/m)	Radiated (μV/m)
30-88	3	40.0	100
88-216	3	43.5	150
216-960	3	46.0	200
Above 960	3	54.0	500

For intentional device, according to § 15.209(a), the general requirement of field strength of radiated emissions from intentional radiators at a distance of 3 meters shall not exceed the above table.

**TEST CONDITION**

The data rate was set at the maximum rate used by the EUT.

The highest fundamental frequency of the EUT is 166MHz, according to § 15.33(a), the radiated emission test was performed within the frequency band 30 – 2000MHz.

**TEST RESULTS**

Operation Mode: Maximum data rate      Temperature: 20 °C      Humidity: 70 % RH      Polarity: Ver. / Hor.

**SCAN TABLE: "test Field(30M-1G)QP"**

Short Description:      Field Strength(30M-1G)  
 Start      Stop      Step      Detector      Meas.      IF      Transducer  
 Frequency      Frequency      Width           Time      Bandw.  
 30.0 MHz      1.0 GHz      60.0 kHz      QuasiPeak      1.0 s      120 kHz      HL562 10

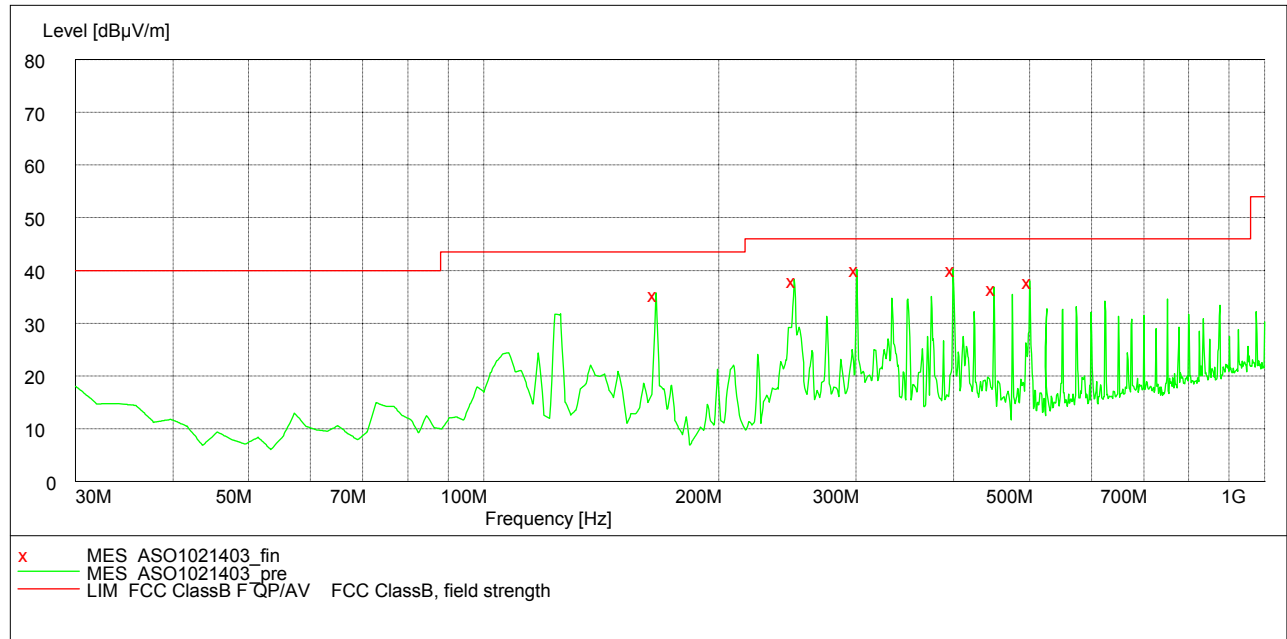

**MEASUREMENT RESULT: "ASO1021403\_fin"**

Frequency (MHz)	Field Strength (dBµV/m)	Limit (dBµV/m)	Margin (dB)	Detect or	Antenna Factor (dB/m)	Cable Loss (dB)	Amplifier Gain (dB)	Reading Amplitude (dBµV)	Polarization
166.070	35.7	43.5	7.8	QP	7.4	7.6	32.0	52.7	Horizontal
249.660	38.3	46.0	7.7	QP	10.5	8.0	31.9	51.7	Horizontal
300.200	40.3	46.0	5.7	QP	12.2	8.3	31.9	51.7	Horizontal
399.340	40.3	46.0	5.7	QP	14.3	8.5	32.0	49.5	Horizontal
449.880	36.8	46.0	9.2	QP	14.5	8.9	32.0	45.4	Horizontal
500.420	38.1	46.0	7.9	QP	15.7	9.2	32.0	45.2	Horizontal

**Remark:**

- (1) Measuring frequencies from 30 MHz to the 1 GHz.
- (2) Data of measurement within this frequency range shown "---" in the table above means the reading of emissions are attenuated more than 20dB below the permissible limits or the field strength is too small to be measured.
- (3) The IF bandwidth of EMI Test Receiver was 120KHz for measuring from 30 MHz to 1 GHz and 1 MHz for measuring above 1 GHz

**SCAN TABLE: "test Field(30M-1G)QP"**

Short Description:		Field Strength(30M-1G)					
Start	Stop	Step	Detector	Meas.	IF	Transducer	
Frequency	Frequency	Width		Time	Bandw.		
30.0 MHz	1.0 GHz	60.0 kHz	QuasiPeak	1.0 s	120 kHz	HL562 10	

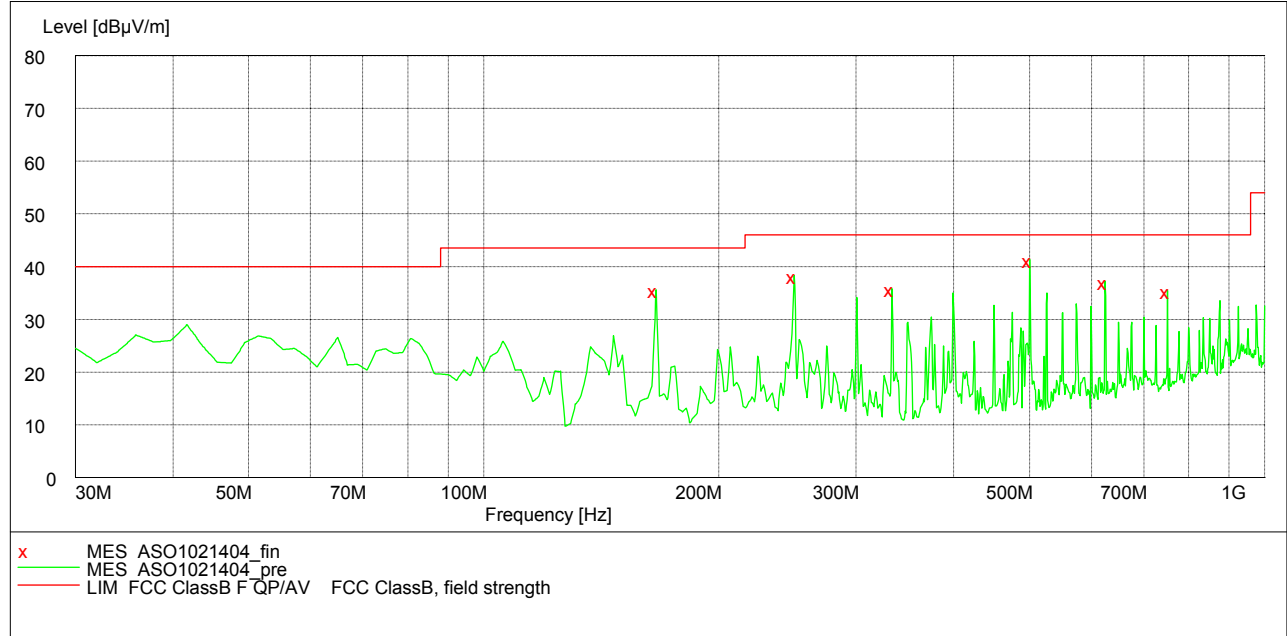

**MEASUREMENT RESULT: "ASO1021404\_fin"**

Frequency (MHz)	Field Strength (dBµV/m)	Limit (dBµV/m)	Margin (dB)	Detect or	Antenna Factor (dB/m)	Cable Loss (dB)	Amplifier Gain (dB)	Reading Amplitude (dBµV)	Polarization
166.070	35.6	43.5	7.9	QP	7.4	7.6	32.0	52.6	Vertical
249.660	38.3	46.0	7.7	QP	10.5	8.0	31.9	51.7	Vertical
333.250	35.8	46.0	10.2	QP	12.5	8.4	31.9	46.8	Vertical
500.420	41.4	46.0	4.6	QP	15.7	9.2	32.0	48.5	Vertical
624.830	37.2	46.0	8.8	QP	17.5	9.3	32.0	42.4	Vertical
751.180	35.5	46.0	10.5	QP	19.3	9.6	31.9	38.5	Vertical

**Remark:**

- (1) Measuring frequencies from 30 MHz to the 1 GHz.
- (2) Data of measurement within this frequency range shown "---" in the table above means the reading of emissions are attenuated more than 20dB below the permissible limits or the field strength is too small to be measured.
- (3) The IF bandwidth of EMI Test Receiver was 120KHz for measuring from 30 MHz to 1 GHz and 1 MHz for measuring above 1 GHz

**SWEEP TABLE: "test (1G-18G) P"**

Short Description: Field Strength(above 1G)  
 Start Stop Detector Meas. IF Transducer  
 Frequency Frequency Time Bandw.  
 1.0 GHz 18.0 GHz MaxPeak Coupled 1 MHz HF906-10

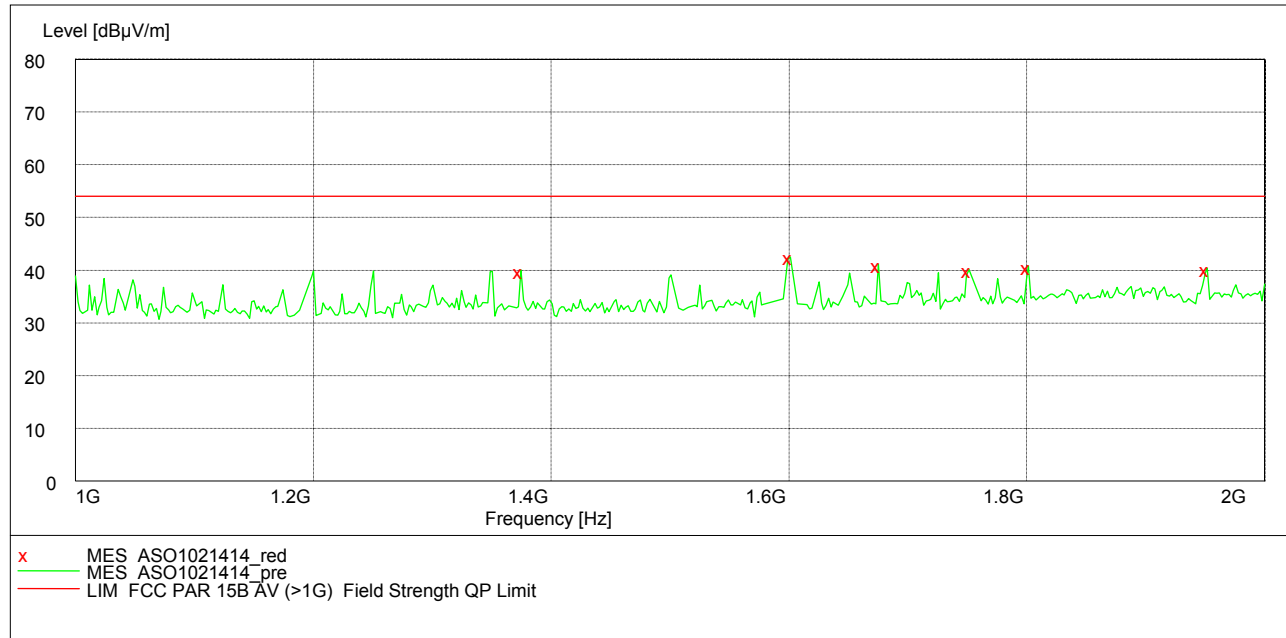

**MEASUREMENT RESULT: "ASO1021414\_red"**

Frequency (MHz)	Field Strength (dBµV/m)	Limit (dBµV/m)	Margin (dB)	Detect or	Antenna Factor (dB/m)	Cable Loss (dB)	Amplifier Gain (dB)	Reading Amplitude (dBµV)	Polarization
1374.74	40.0	54.0	14.0	Peak	25.6	3.5	31.9	42.8	Horizontal
1601.20	42.5	54.0	11.5	Peak	25.5	3.8	32.0	45.2	Horizontal
1675.35	41.1	54.0	12.9	Peak	25.9	3.9	32.0	43.3	Horizontal
1751.50	40.1	54.0	13.9	Peak	26.4	4.1	32.0	41.6	Horizontal
1801.60	40.8	54.0	13.2	Peak	26.5	4.1	32.0	42.2	Horizontal
1951.90	40.4	54.0	13.6	Peak	27.3	4.2	32.1	41.0	Horizontal

**Remark:**

- (1) Measuring frequencies from 1 GHz to the 2 GHz.
- (2) Data of measurement within this frequency range shown "----" in the table above means the reading of emissions are attenuated more than 20dB below the permissible limits or the field strength is too small to be measured.
- (3) The RBW of EMI Test Receiver was 1MHz and the VBW was 3MHz for measuring from 1 GHz to 2 GHz.
- (4) The average measurement was not performed when the peak measured data under the limit of average detection.

**SWEEP TABLE: "test (1G-18G) P"**

Short Description: Field Strength(above 1G)  
 Start Stop Detector Meas. IF Transducer  
 Frequency Frequency Time Bandw.  
 1.0 GHz 18.0 GHz MaxPeak Coupled 1 MHz HF906-10

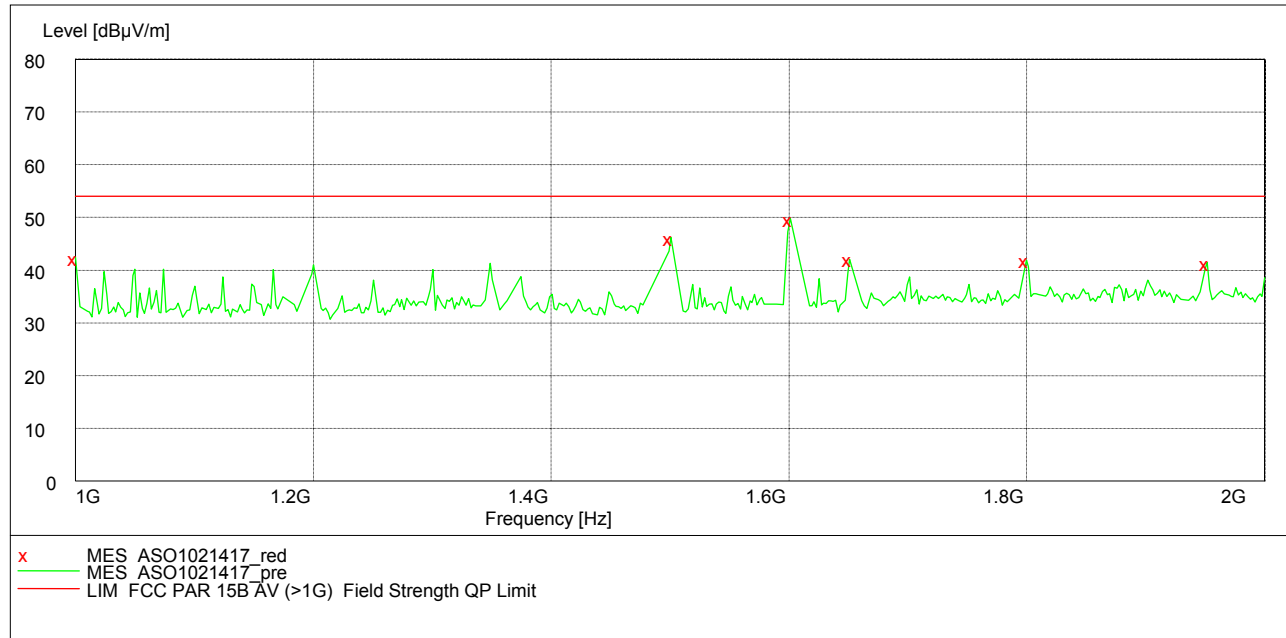

**MEASUREMENT RESULT: "ASO1021417\_red"**

Frequency (MHz)	Field Strength (dBµV/m)	Limit (dBµV/m)	Margin (dB)	Detect or	Antenna Factor (dB/m)	Cable Loss (dB)	Amplifier Gain (dB)	Reading Amplitude (dBµV)	Polarization
1000.00	42.4	54.0	11.6	Peak	24.6	3.1	31.9	46.6	Vertical
1501.00	46.2	54.0	7.8	Peak	24.8	3.7	31.9	49.6	Vertical
1601.20	49.8	54.0	4.2	Peak	25.5	3.8	32.0	52.5	Vertical
1651.30	42.1	54.0	11.9	Peak	25.7	3.9	32.0	44.5	Vertical
1799.59	41.9	54.0	12.1	Peak	26.5	4.1	32.0	43.3	Vertical
1951.90	41.4	54.0	12.6	Peak	27.3	4.2	32.1	42.0	Vertical

**Remark:**

- (1) Measuring frequencies from 1 GHz to the 2 GHz.
- (2) Data of measurement within this frequency range shown "---" in the table above means the reading of emissions are attenuated more than 20dB below the permissible limits or the field strength is too small to be measured.
- (3) The RBW of EMI Test Receiver was 1MHz and the VBW was 3MHz for measuring from 1 GHz to 2 GHz.
- (4) The average measurement was not performed when the peak measured data under the limit of average detection.

## 5. Test Setup Photos of the EUT



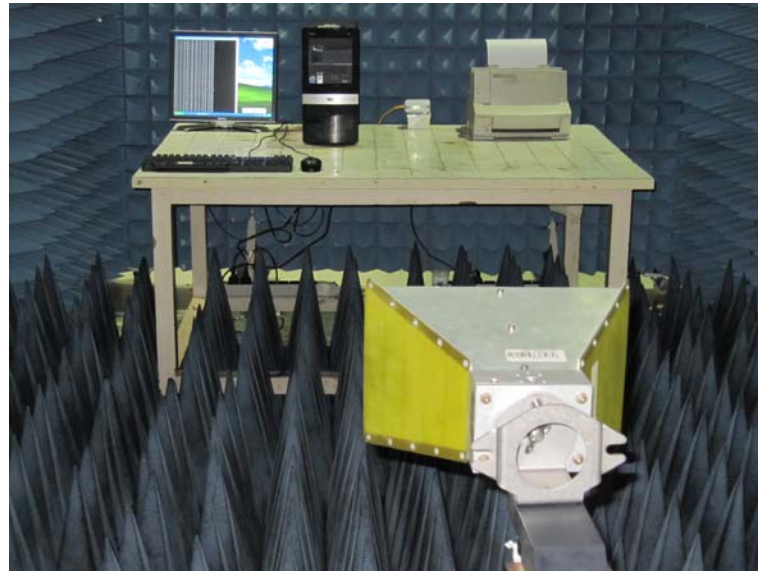

## 6. External and Internal Photos of the EUT

### External Photos





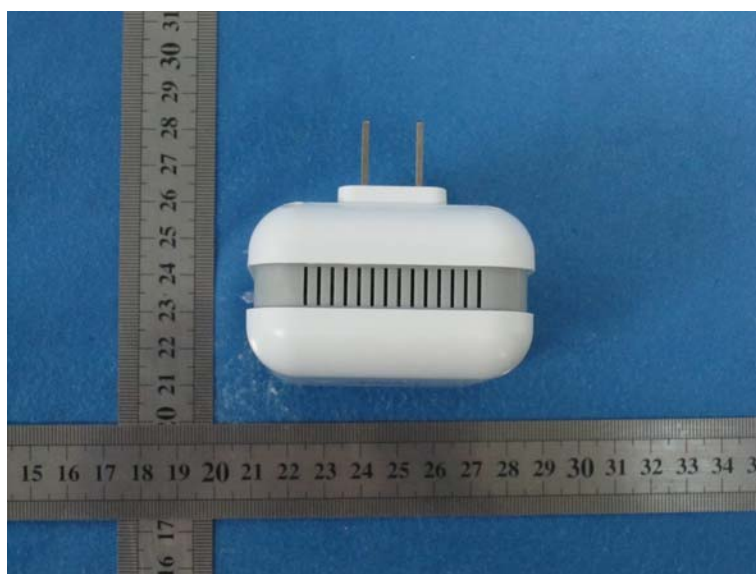
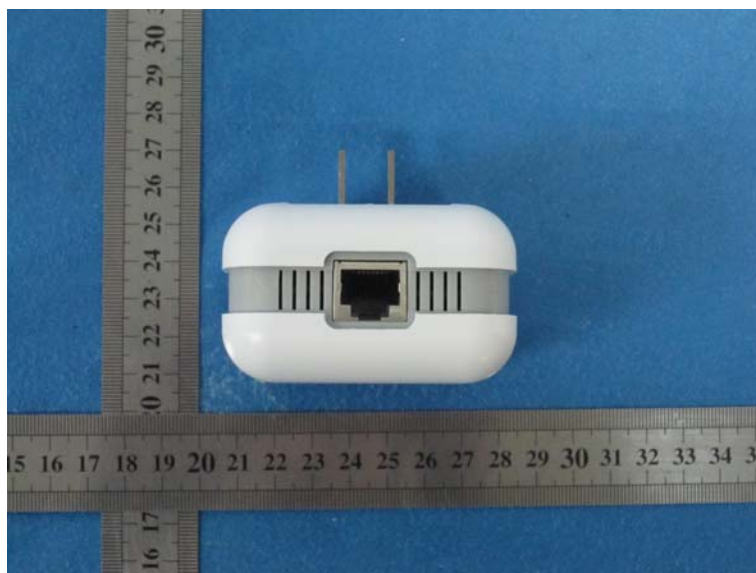

Internal Photos

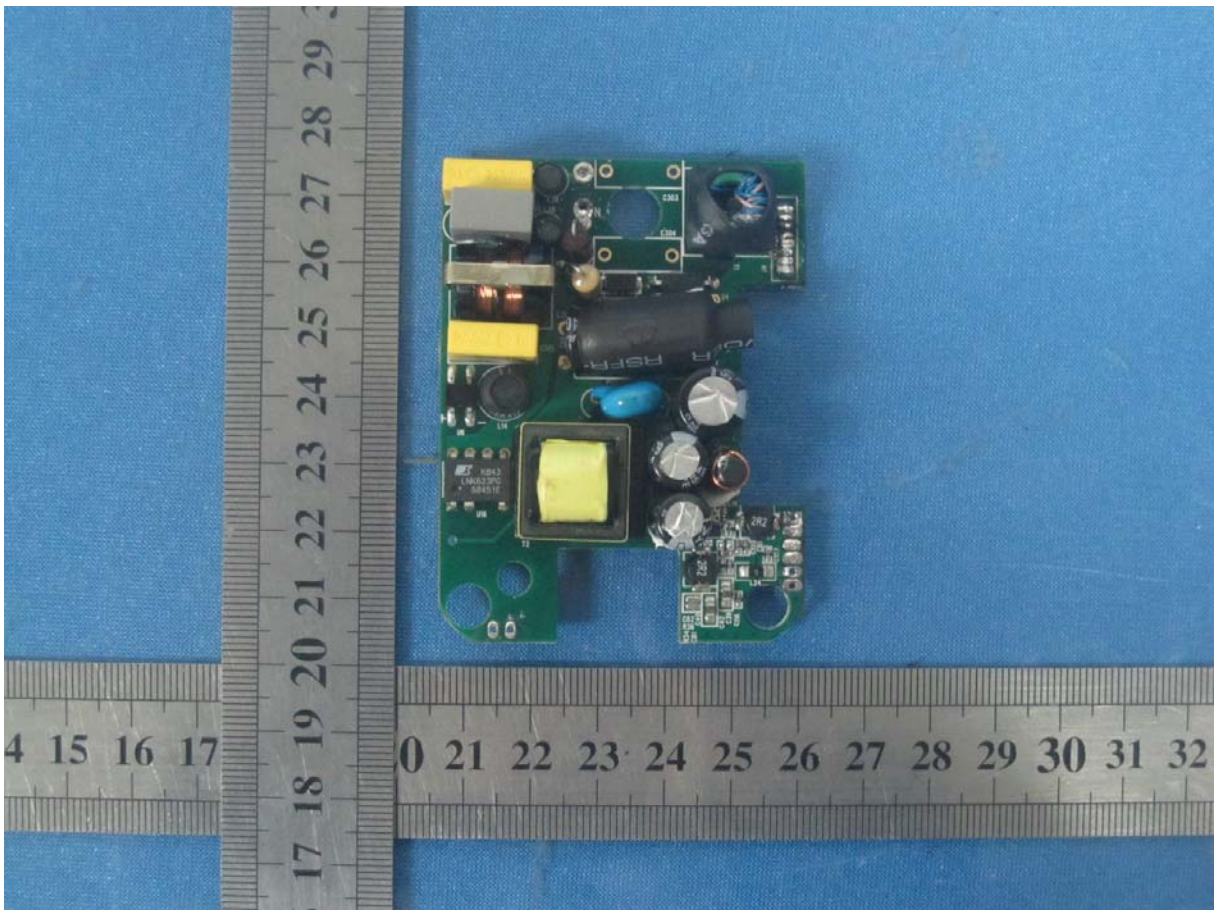
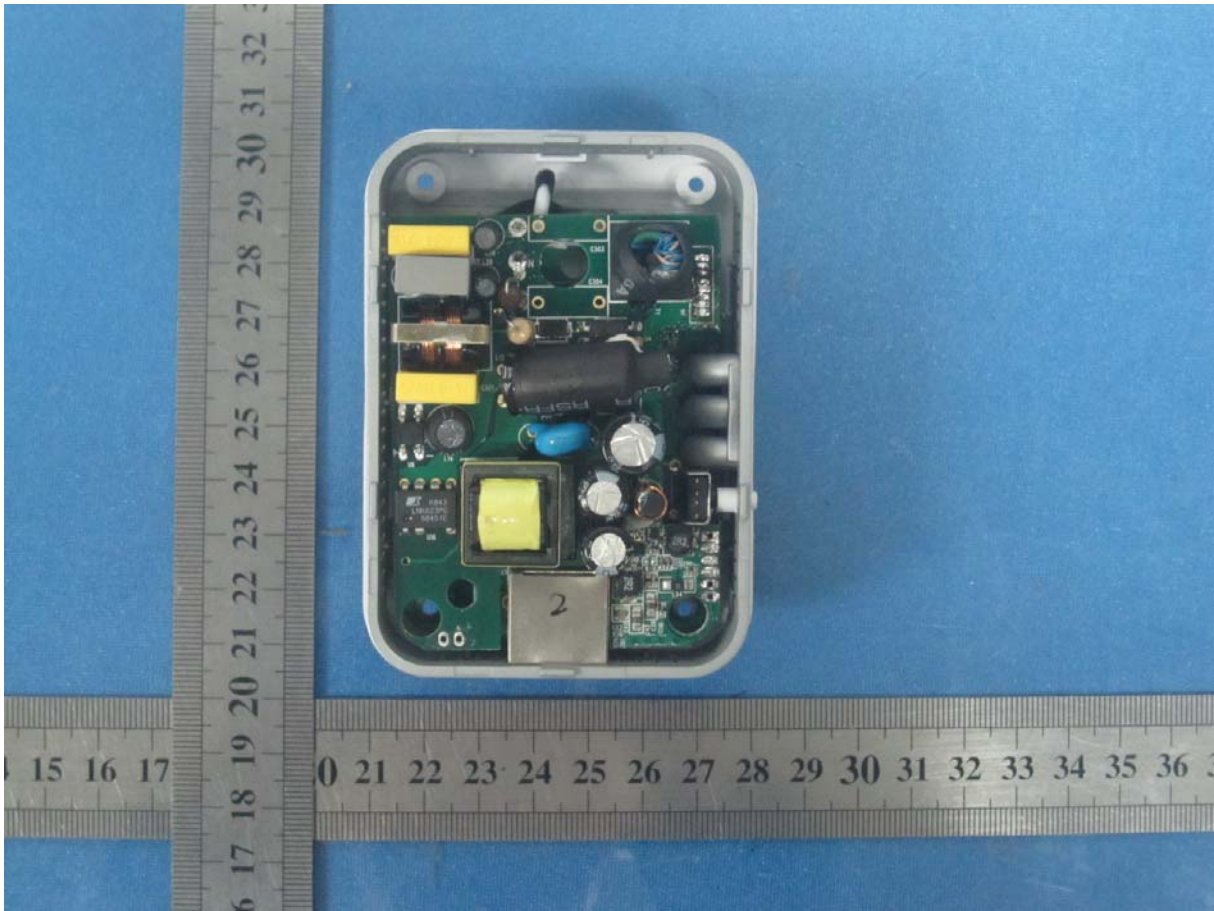

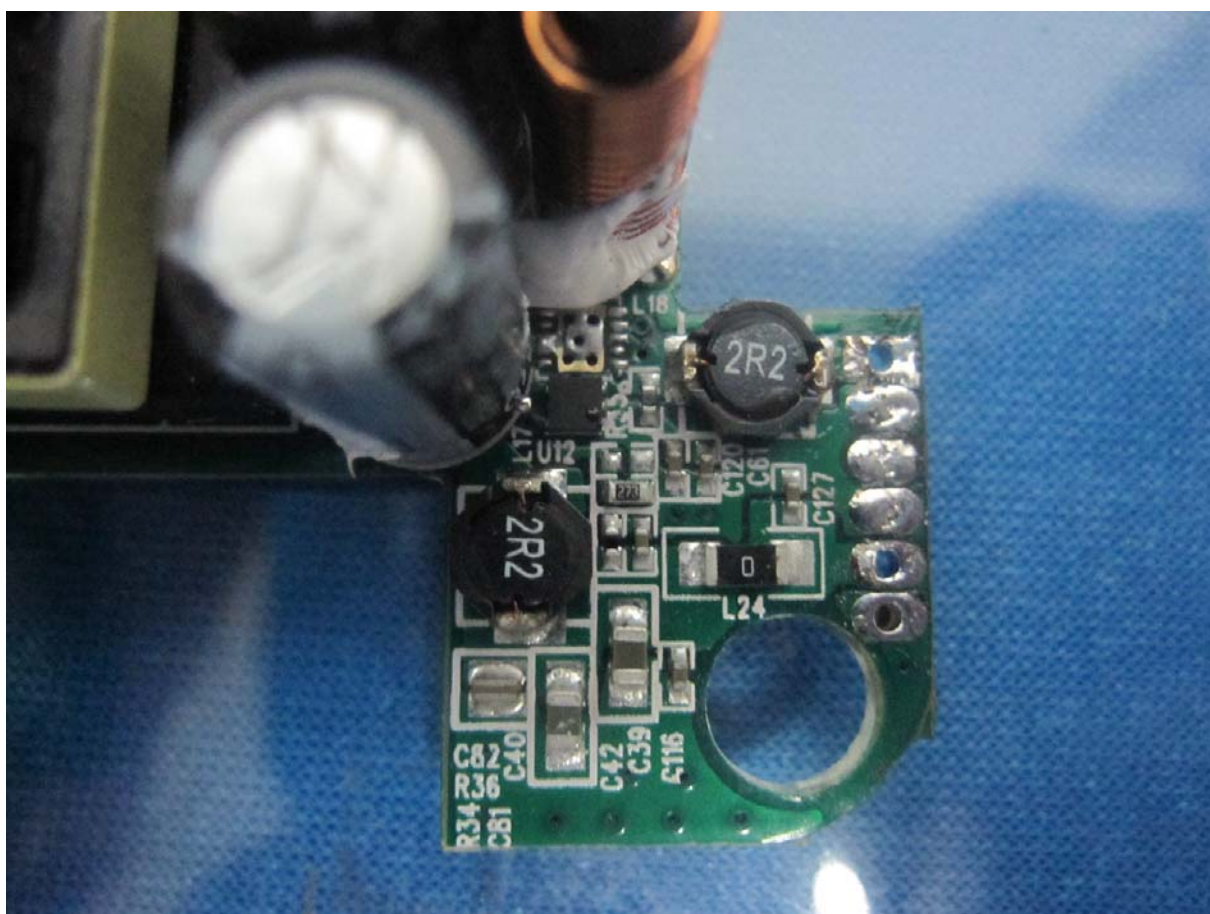
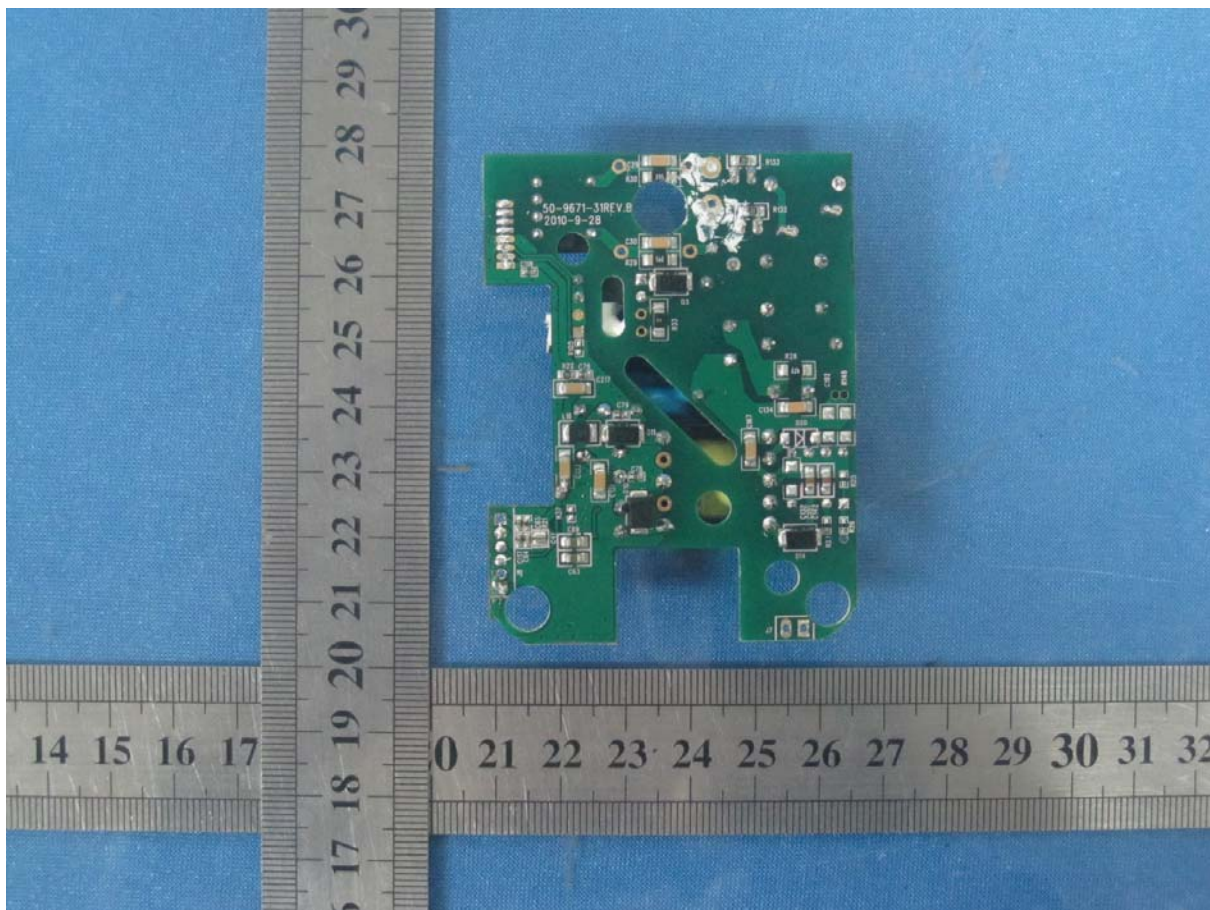

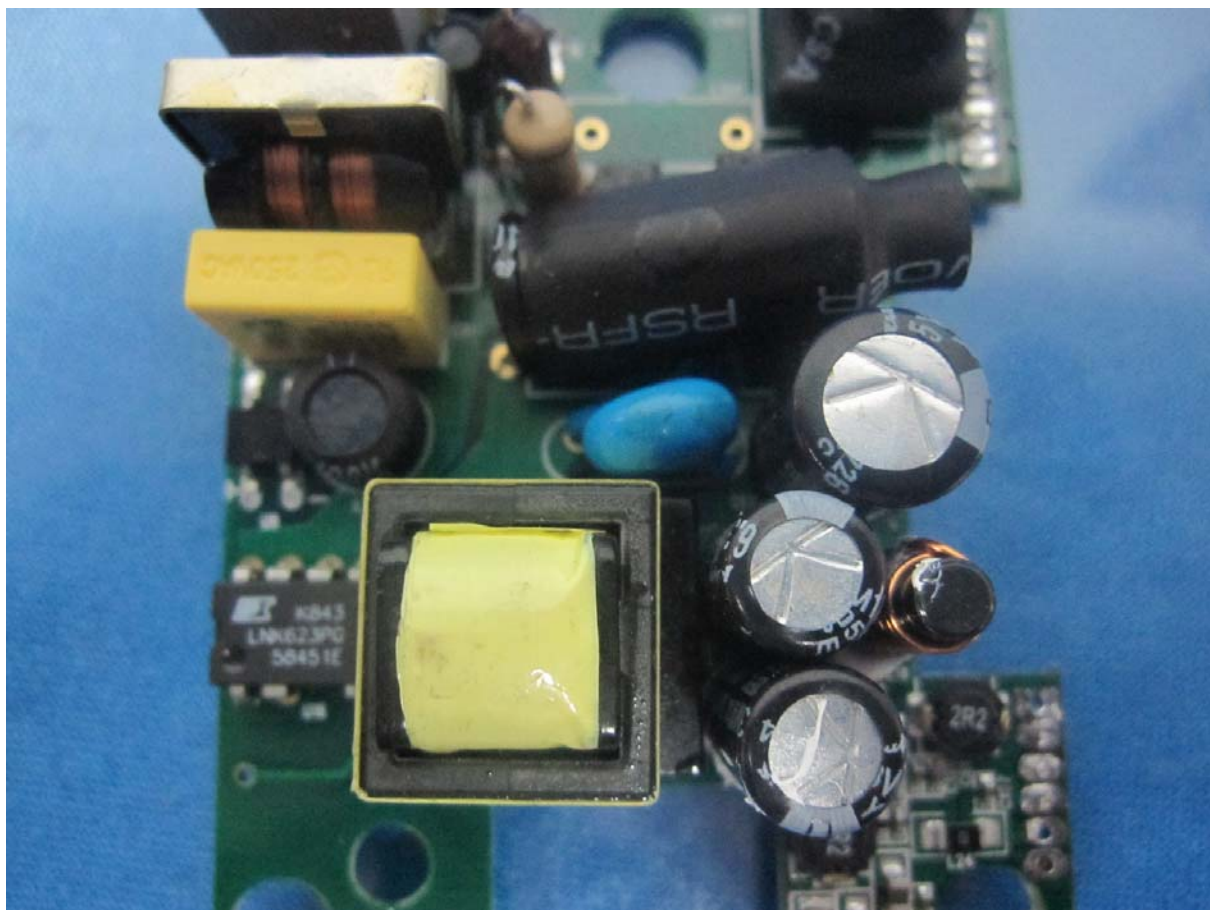

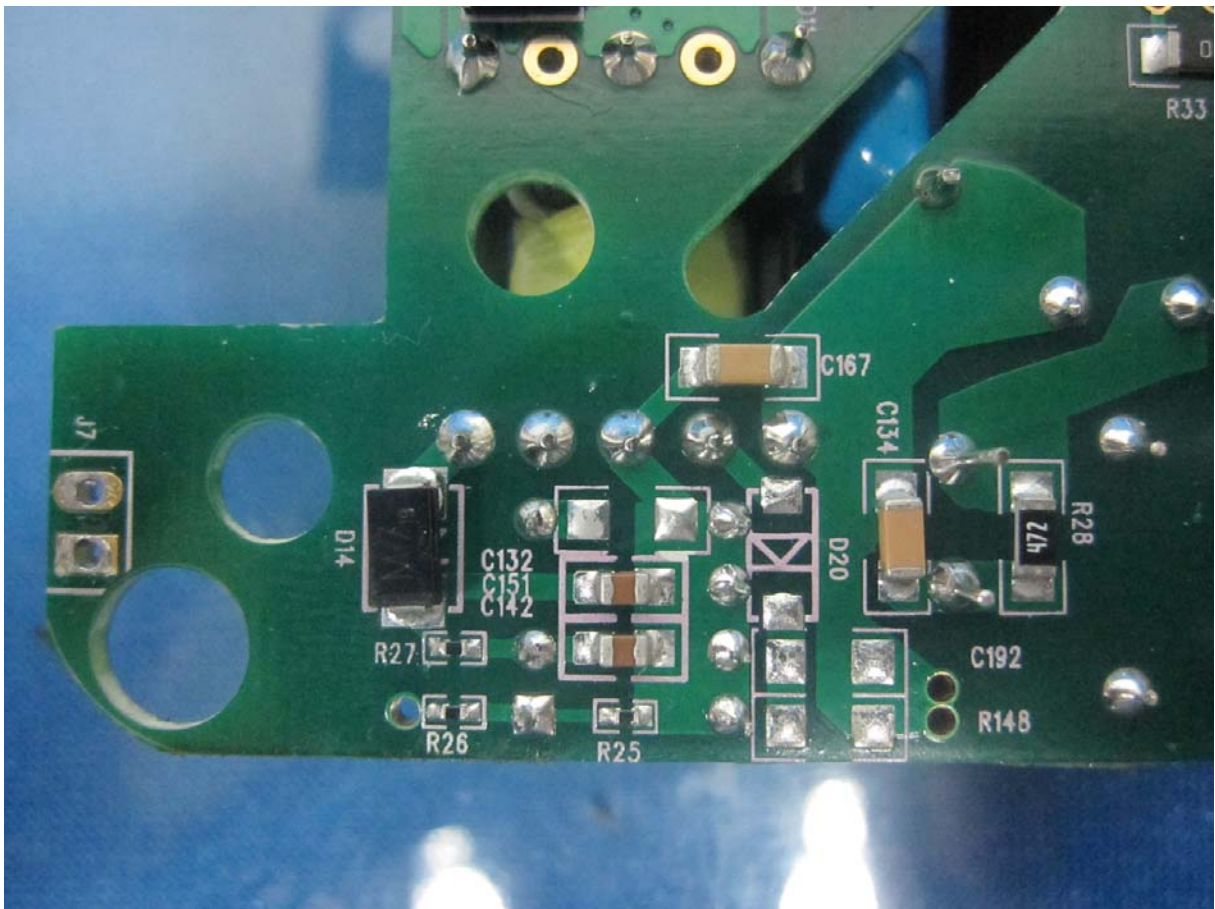
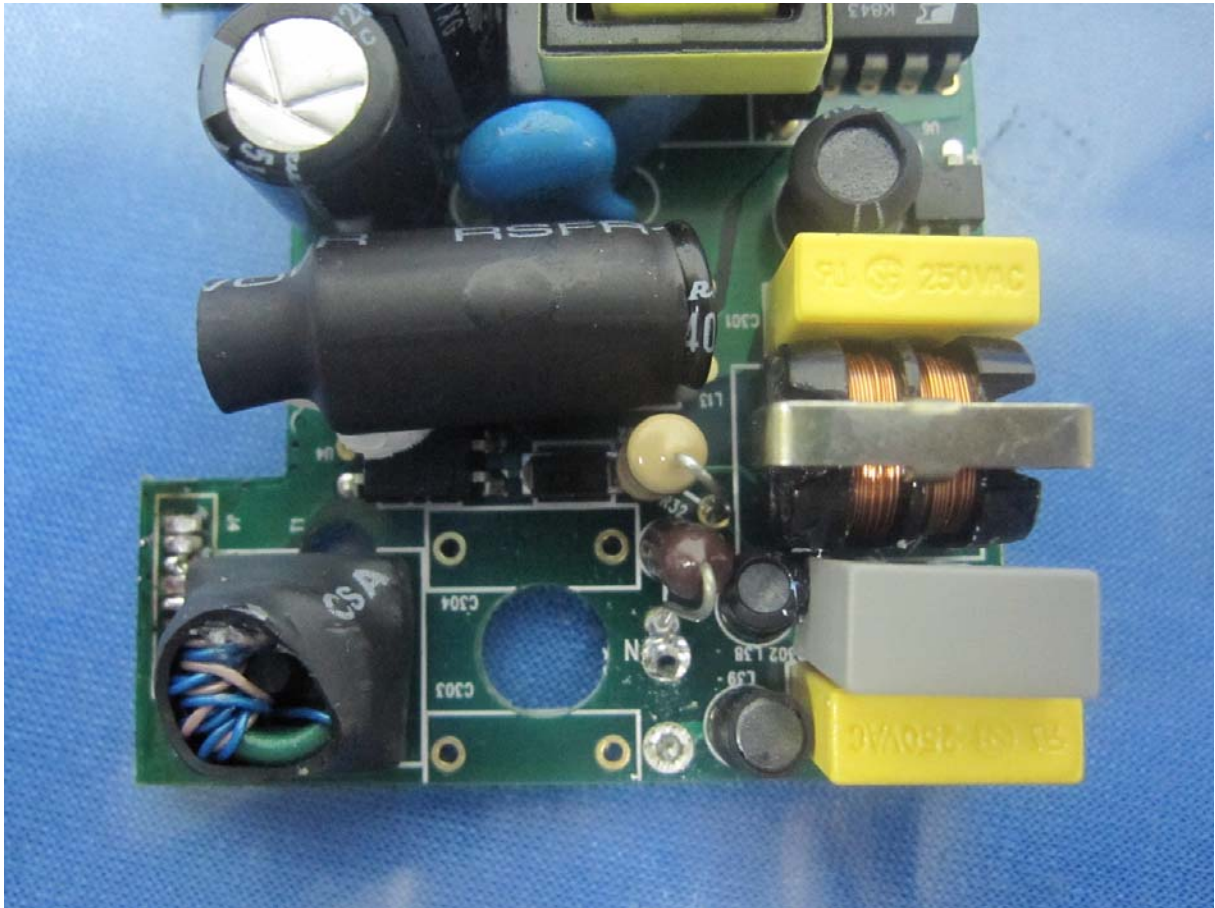

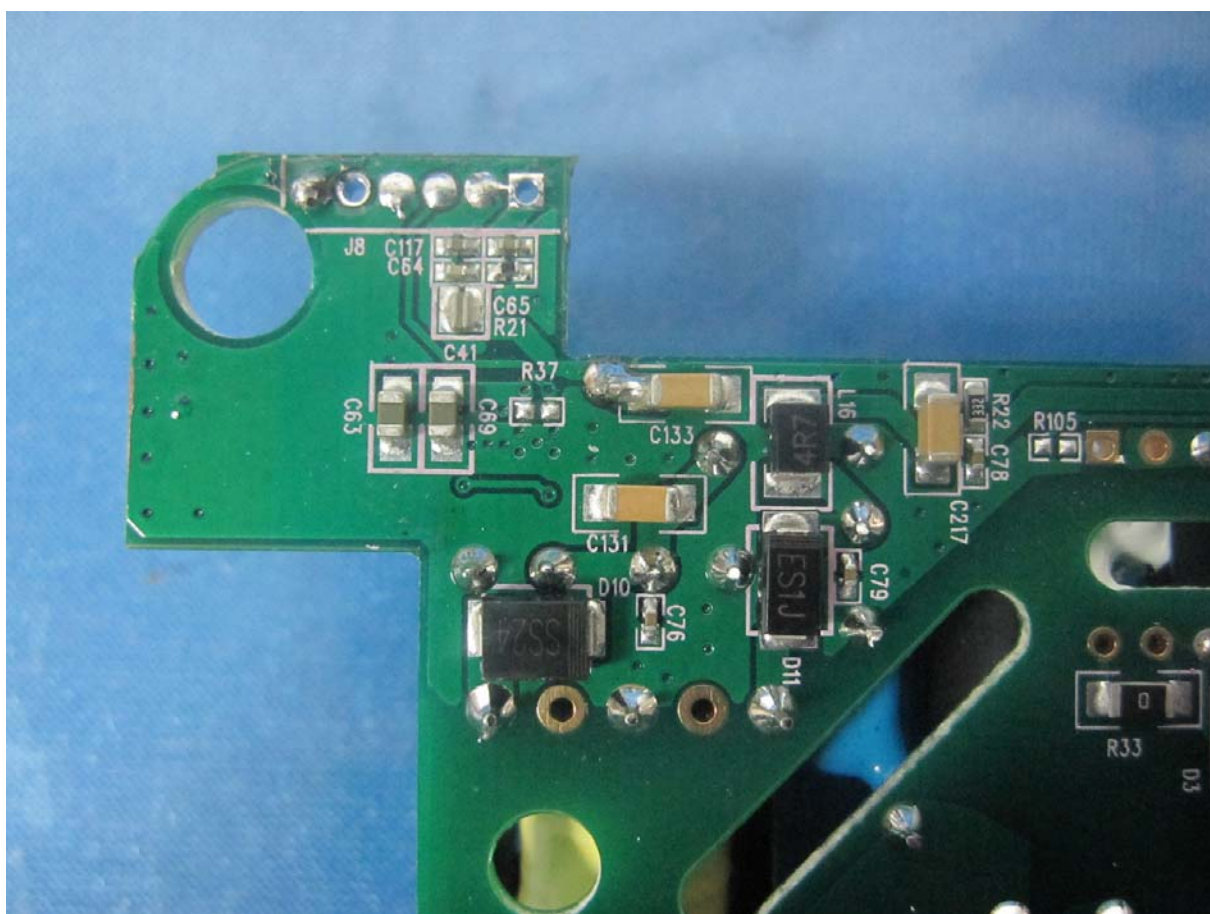
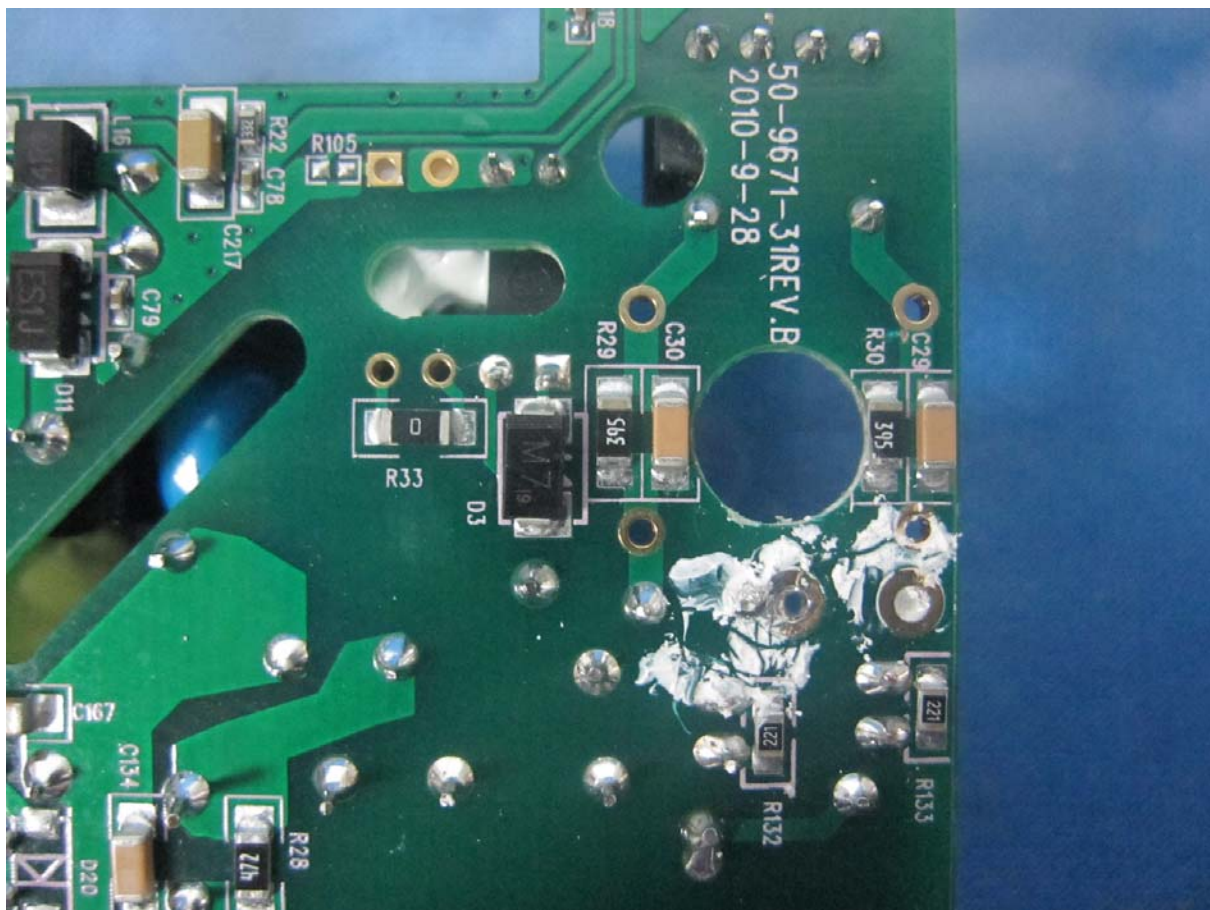

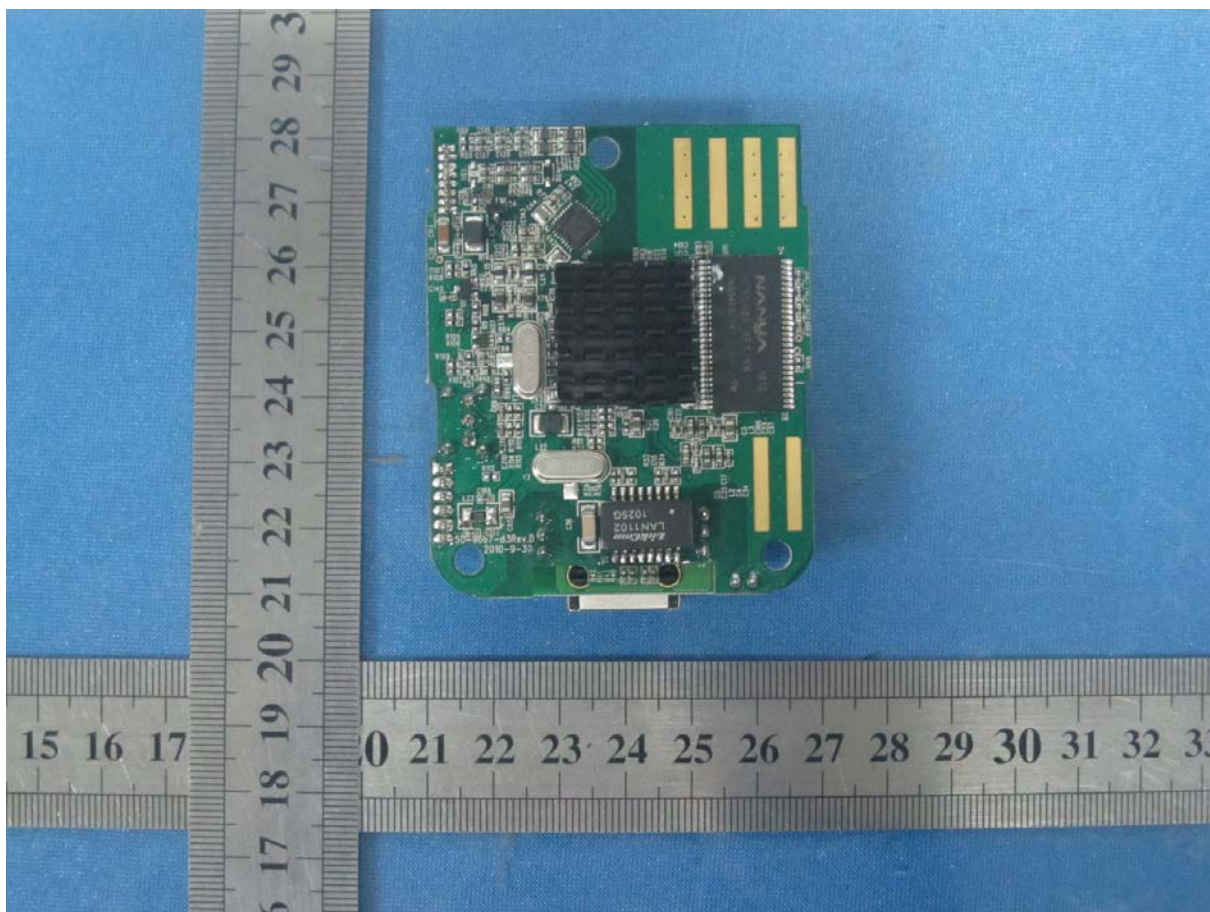
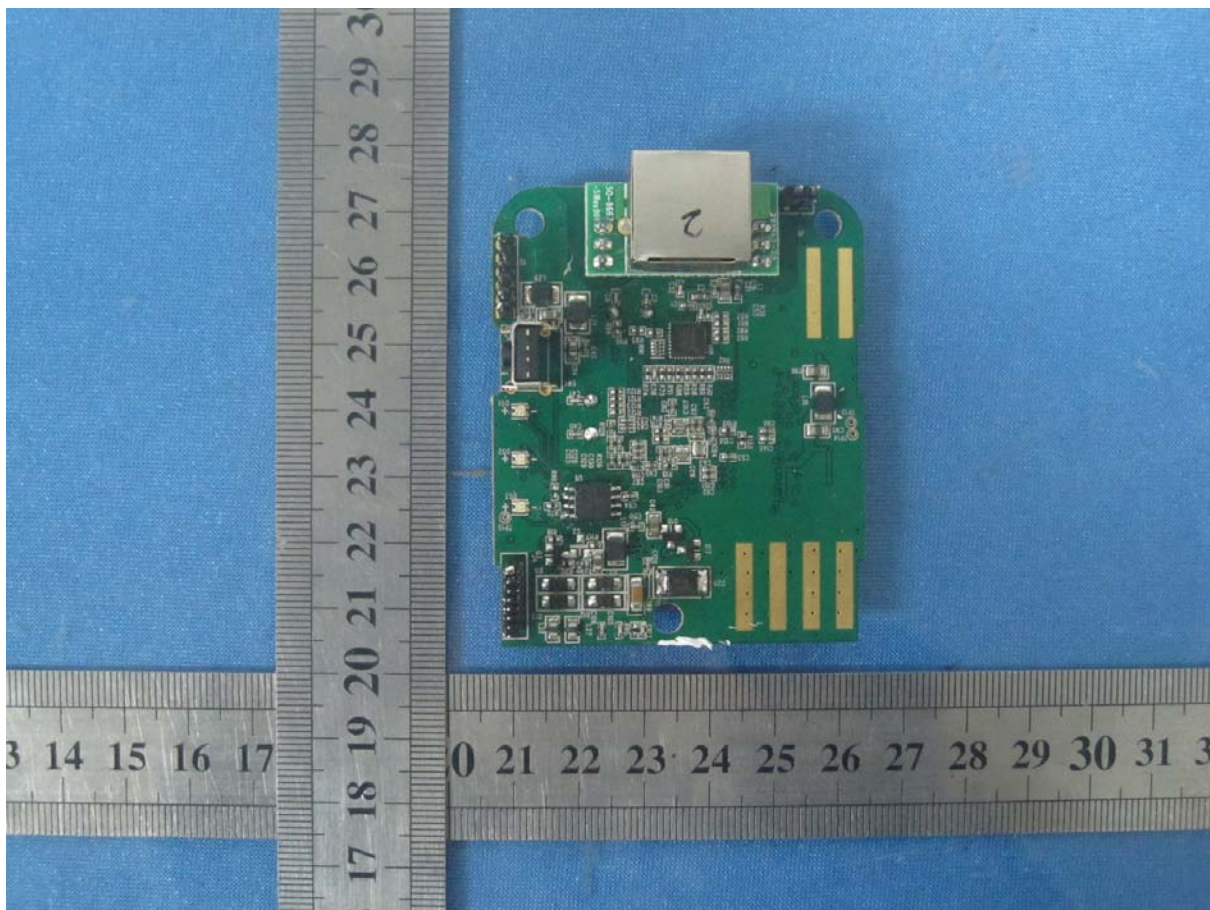

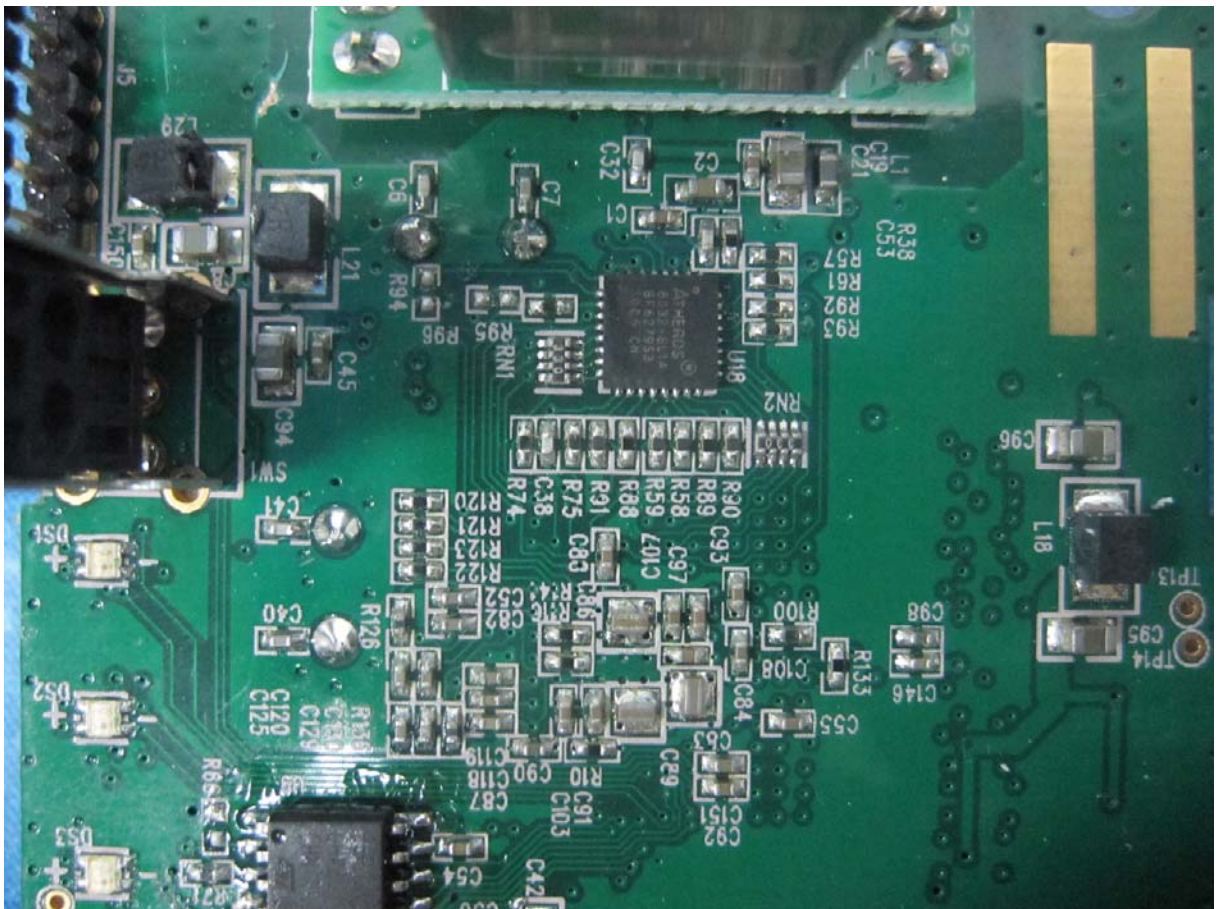
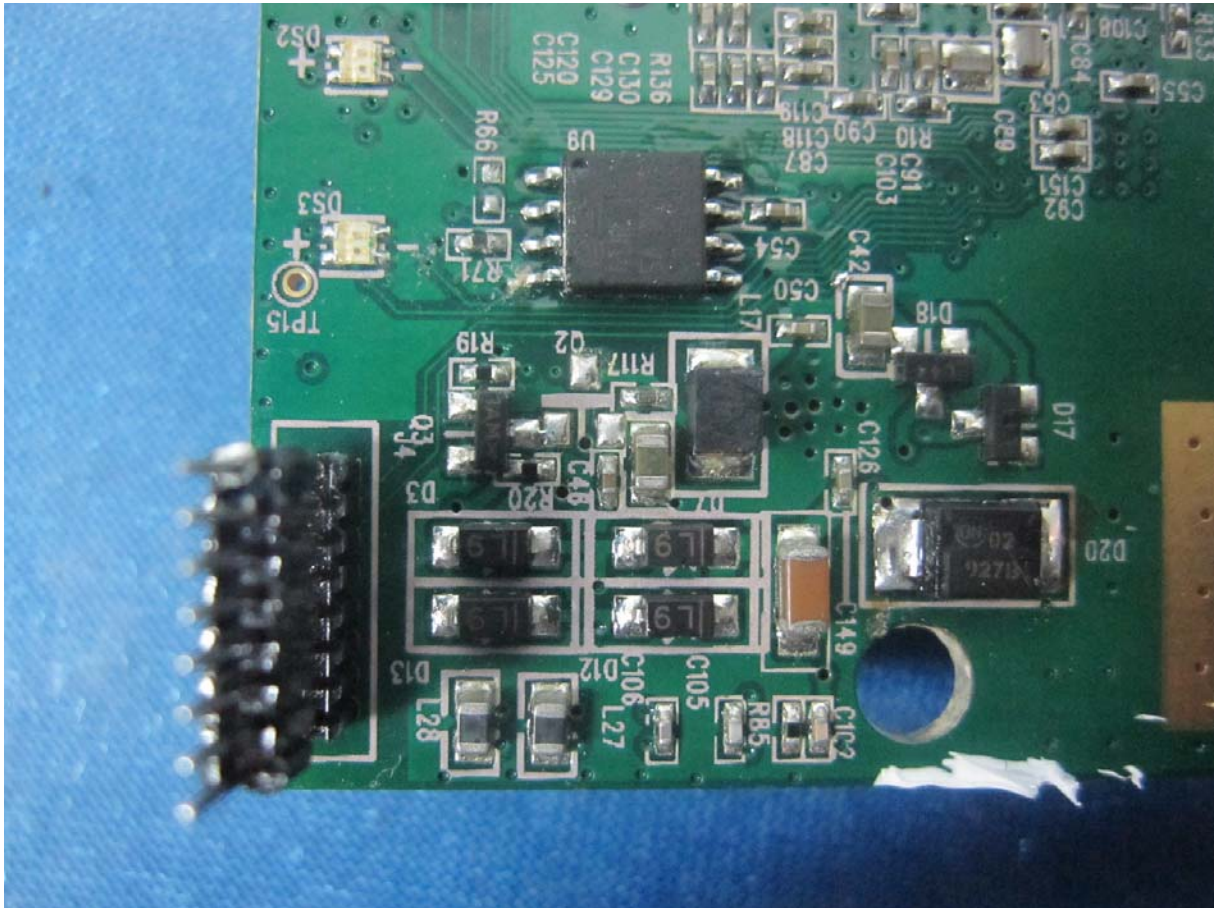





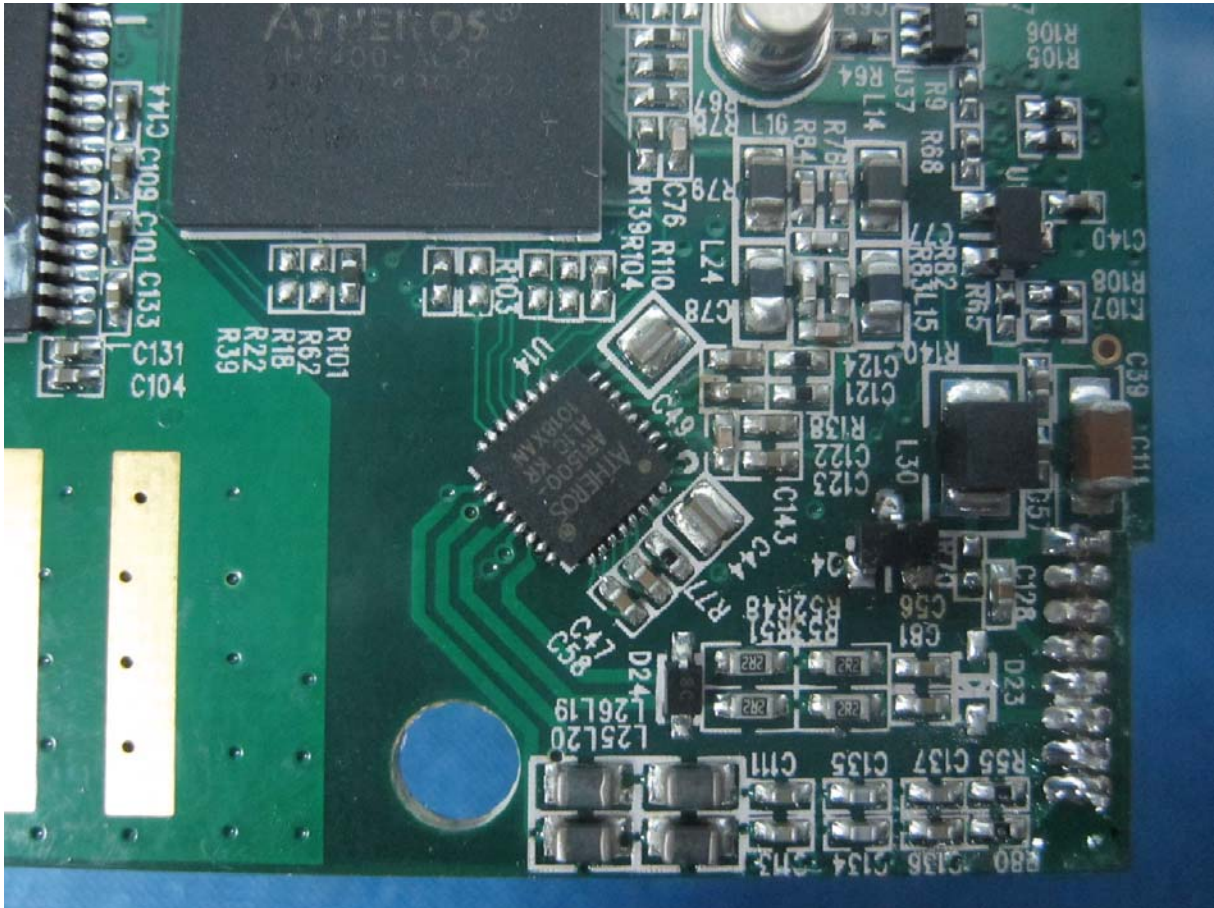

.....End of Report.....