

DATE	REVISION	DESCRIPTION
08/26/2008	A	INITIAL RELEASE
10/28/2008	B	add FB1 & FB2
2/25/2009	C	remove R112
3/18/2009	D	swap GPIO7 and GPIO9 on 50-pin connector

CONFIDENTIAL

Copyright 2008. Asoka USA Corporation. All Rights Reserved.
 This document contains confidential information of Asoka USA Corporation. In consideration of the receipt of this document, recipient agrees not to reproduce or make this information available in any manner to persons outside the group directly responsible for evaluation of its contents.

ASOKA-USA, CORPORATION		
2344-A Walsh Ave Santa Clar, CA 95051 1-650-286-1700		
Title SM6400-50-PIN		
Size A	Document Number SCH-80-6400A-01	Rev D
Date: Wednesday, March 18, 2009 Sheet 1 of 6		

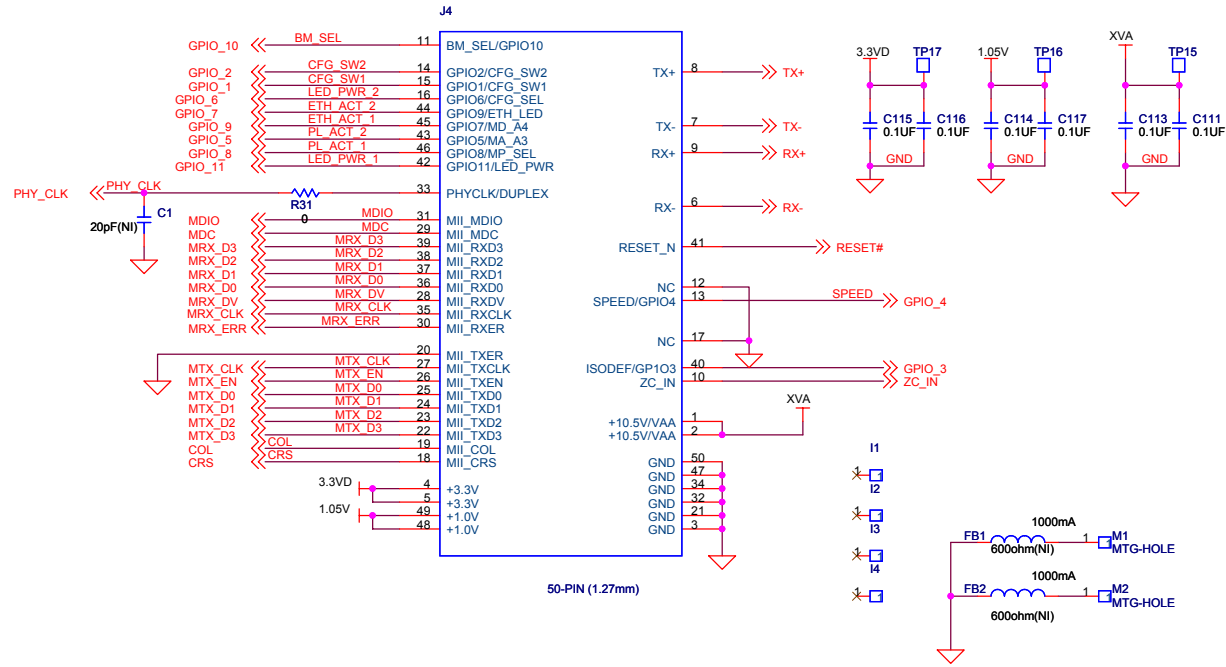

CONFIDENTIAL

Copyright 2008. Asoka USA Corporation. All Rights Reserved. This document contains confidential information of Asoka USA Corporation. In consideration of the receipt of this document, recipient agrees not to reproduce or make this information available in any manner to persons outside the group directly responsible for evaluation of its contents.

ASOKA USA CORPORATION		
2344-A Walsh Ave Santa Clar, CA 95051 1-650-286-1700		
Title		
SM6400-50-PIN		
Size	Document Number	Rev
Custom	SCH-80-6400A-01	D
Date:	Wednesday, March 18, 2009	Sheet 2 of 6

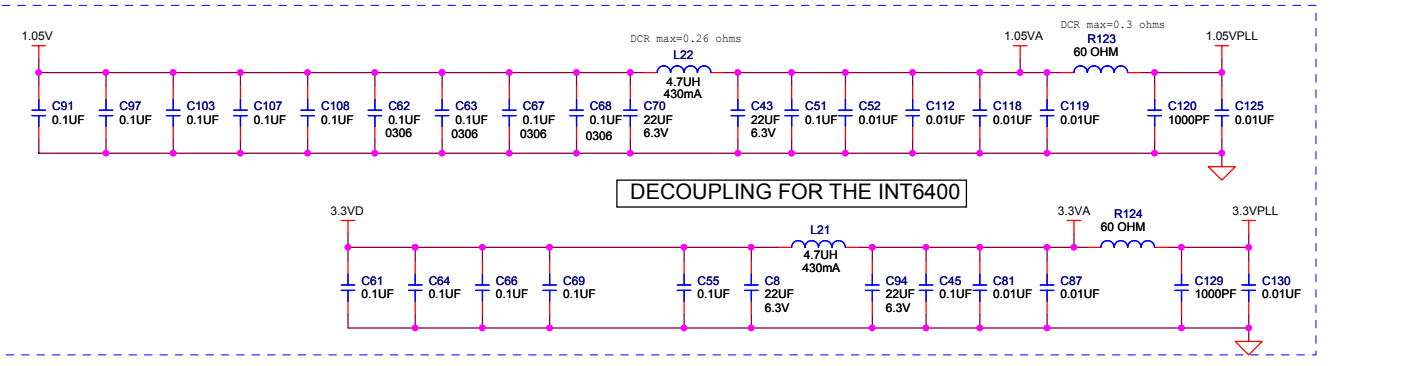
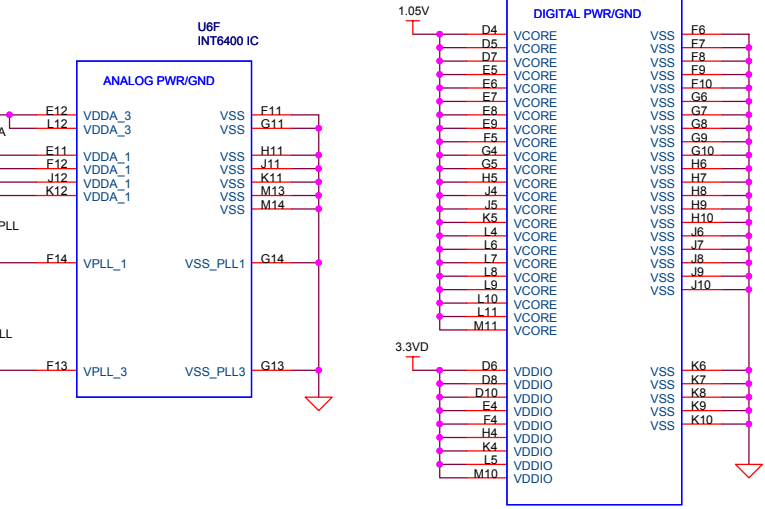
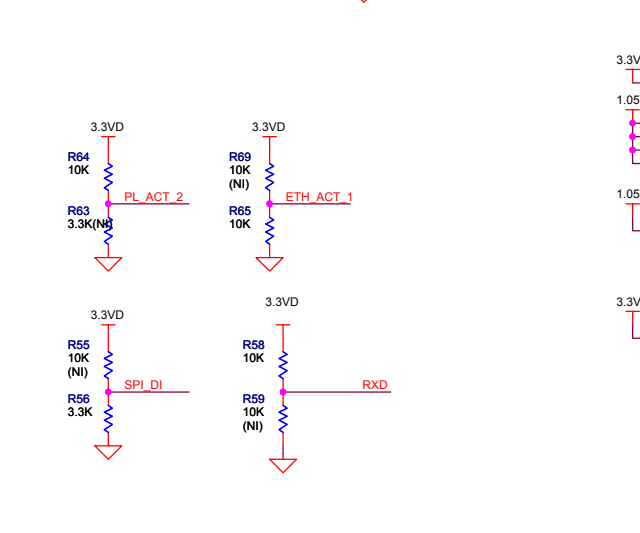
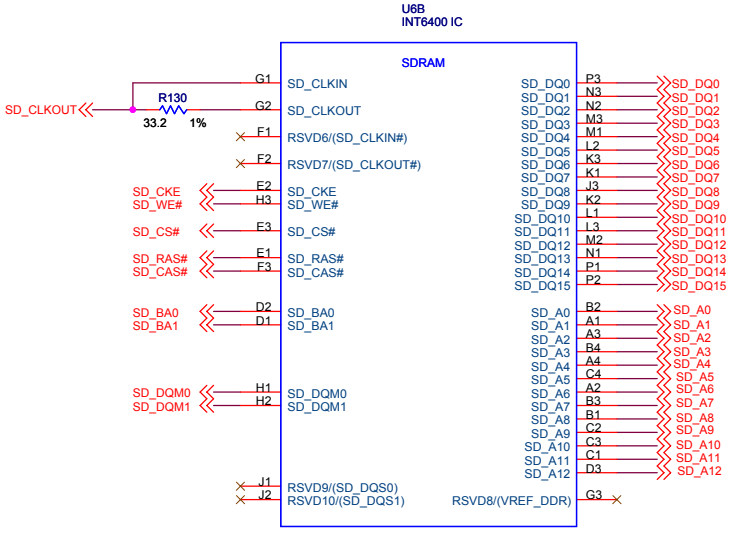
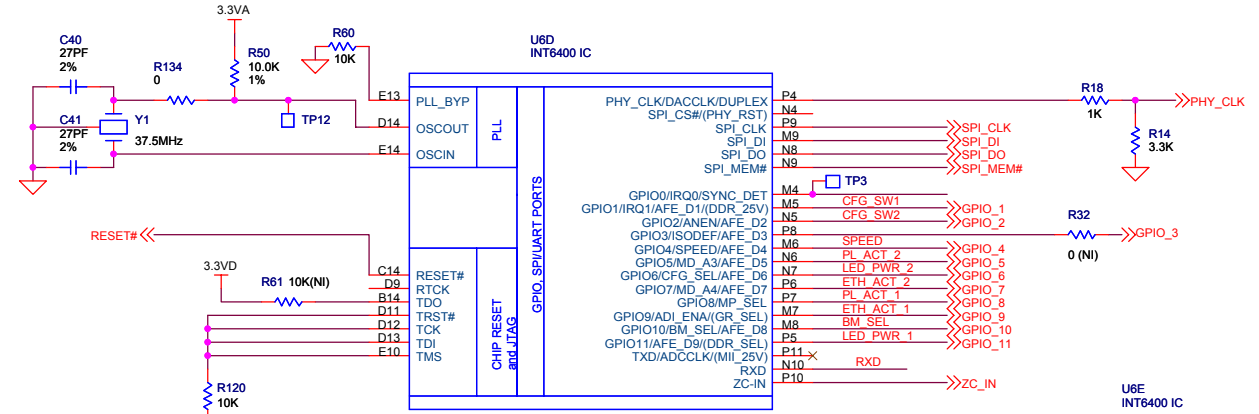
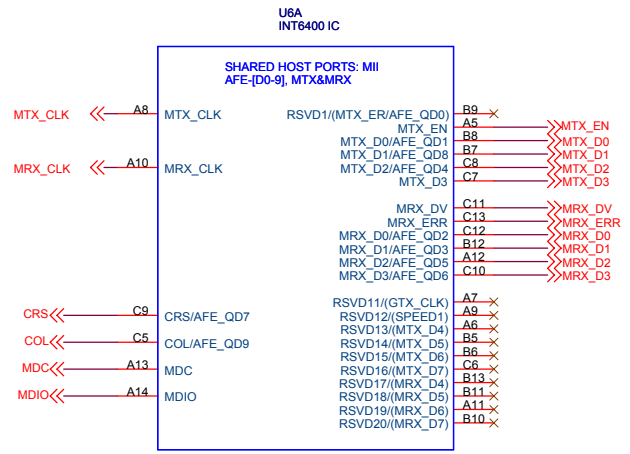

CONFIDENTIAL

Copyright 2008. Asoka USA Corporation. All Rights Reserved. This document contains confidential information of Asoka USA Corporation. In consideration of the receipt of this document, recipient agrees not to reproduce or make this information available in any manner to persons outside the group directly responsible for evaluation of its contents.

ASOKA-USA, CORPORATION		
2344-A Walsh Ave Santa Clar, CA 95051 1-850-286-1700		
Title: SM6400-50-PIN		
Size: Custom	Document Number: SCH-80-6400A-01	Rev: D
Date: Wednesday, March 18, 2009	Sheet: 3	of 6

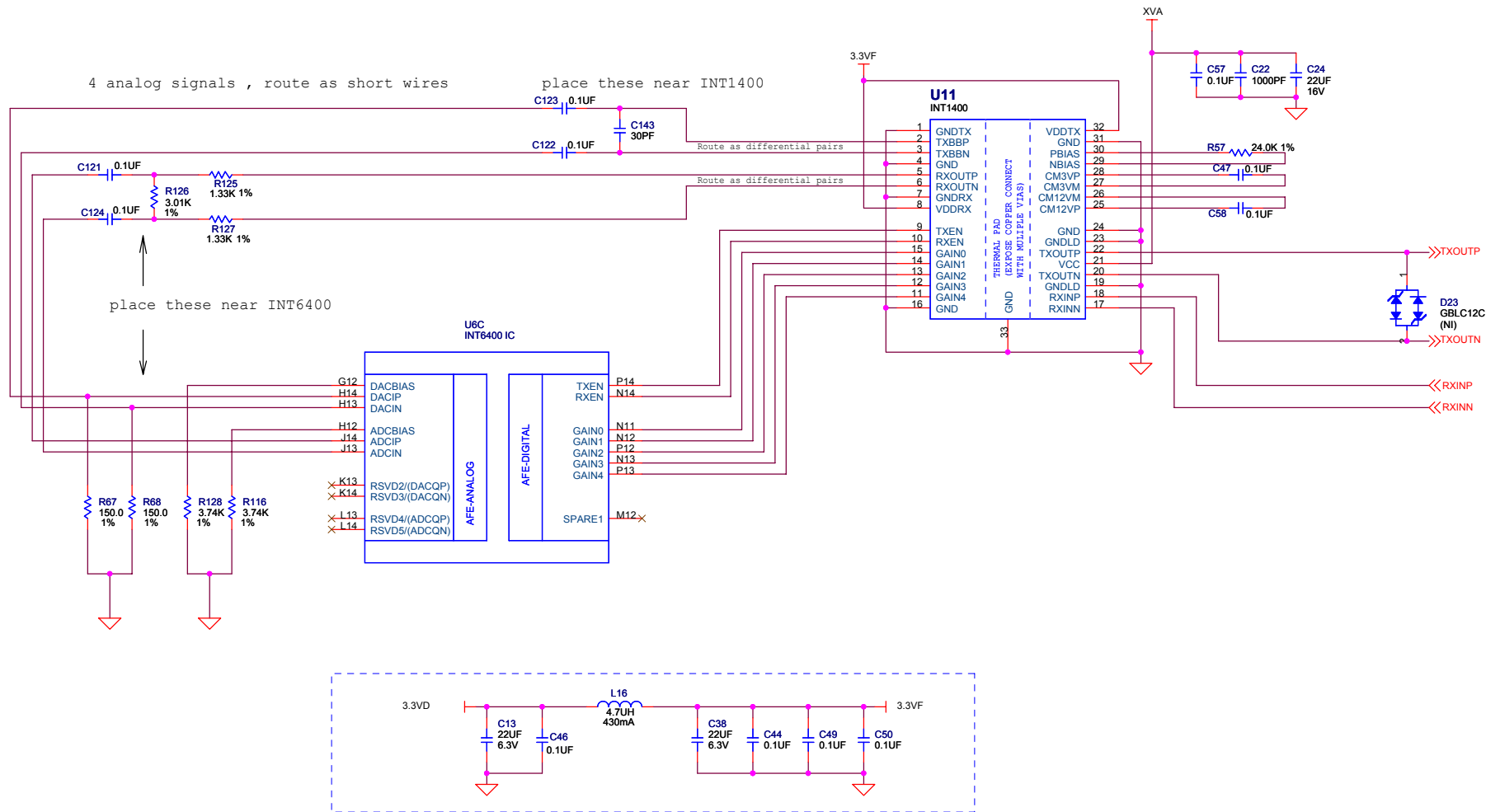

CONFIDENTIAL

Copyright 2008. Asoka USA Corporation. All Rights Reserved.
 This document contains confidential information of Asoka USA Corporation. In consideration of the receipt of this document, recipient agrees not to reproduce or make this information available in any manner to persons outside the group directly responsible for evaluation of its contents.

ASOKA-USA, CORPORATION		
2344-A Walsh Ave Santa Clar, CA 95051 1-650-286-1700		
Title		SM6400-50-PIN
Size	Document Number	Rev
Custom	SCH-80-6400A-01	D
Date:	Wednesday, March 18, 2009	Sheet 4 of 6

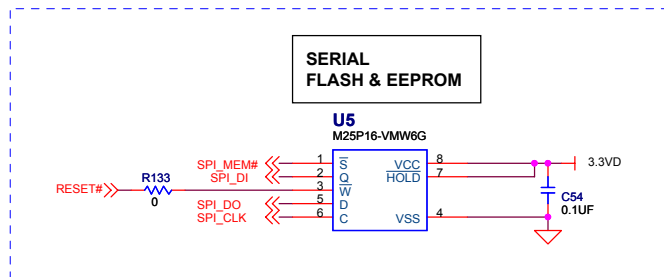

SDRAM

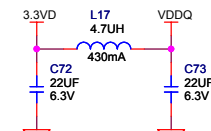
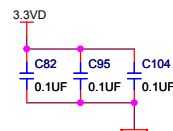
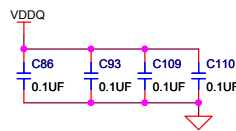
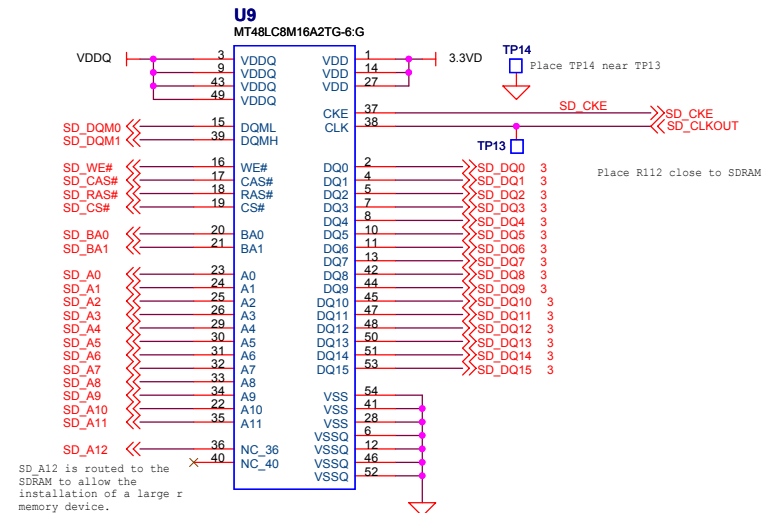

CONFIDENTIAL

Copyright 2008. Asoka USA Corporation. All Rights Reserved. This document contains confidential information of Asoka USA Corporation. In consideration of the receipt of this document, recipient agrees not to reproduce or make this information available in any manner to persons outside the group directly responsible for evaluation of its contents.

ASOKA-USA, CORPORATION		
2344-A Walsh Ave Santa Clar, CA 95051 1-650-286-1700		
Title		
SM6400-50-PIN		
Size	Document Number	Rev
Custom	SCH-80-6400A-01	D
Date:	Wednesday, March 18, 2009	Sheet 5 of 6

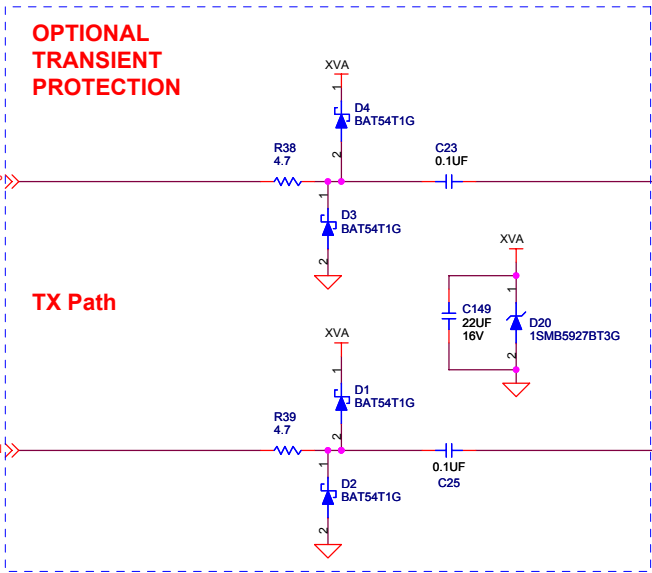

RX BANDPASS FILTER

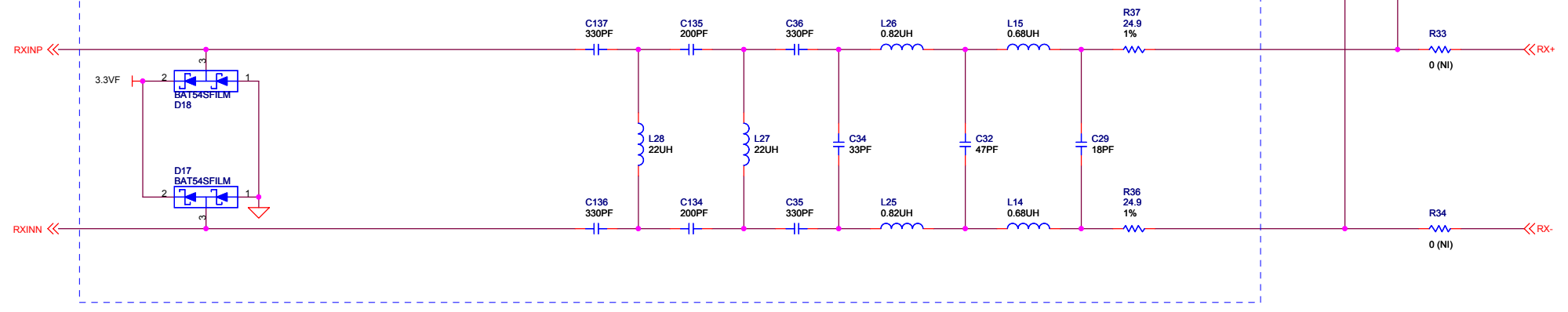

CONFIDENTIAL

Copyright 2008. Asoka USA Corporation. All Rights Reserved. This document contains confidential information of Asoka USA Corporation. In consideration of the receipt of this document, recipient agrees not to reproduce or make this information available in any manner to persons outside the group directly responsible for evaluation of its contents.

ASOKA-USA, CORPORATION		
2344-A Walsh Ave Santa Clar, CA 95051 1-650-286-1700		
Title		SM6400-50-PIN
Size	Document Number	Rev
Custom	SCH-80-6400A-01	D
Date:	Wednesday, March 18, 2009	Sheet 6 of 6