



Shenzhen Huatongwei International Inspection Co., Ltd.

Keji S, 12th, Road, Hi-tech Industrial Park, Shenzhen, Guangdong, China

Phone: 86-755-26748099

Fax: 86-755-26748089

http://www.szhtw.com.cn



FCC TEST REPORT

47 CFR FCC Part 15 Subpart B

FCC ID.....: **T37PL9571-WAP**

Report Reference No......: **TRE1209009502 R/C:82725**

Compiled by

(position+printed name+signature)..: File administrators Tim Zhang

Tim Zhang

Supervised by

(position+printed name+signature)..: Test Engineer Eric Zhang

Eric Zhang

Approved by

(position+printed name+signature)..: Manager Wenliang Li

Wenliang Li

Date of issue.....: Feb 19, 2013

Testing Laboratory Name: **Shenzhen Huatongwei International Inspection Co., Ltd**

Address: Keji Nan No.12 Road, Hi-tech Park, Shenzhen, China

Applicant's name.....: **ASOKA Shenzhen Limited.**

Address: Room 1701,17/F., Fiyta Hi Tech Building, Gao-Xin Rd, South, Shenzhen, P R China

Test specification:

Standard.....: **47 CFR FCC Part 15 Subpart B - Unintentional Radiators**

ANSI C63.4: 2009

TRF Originator.....: Shenzhen Huatongwei International Inspection CO., Ltd

Master TRF.....: Dated 2006-06

Shenzhen Huatongwei International Inspection Co., Ltd. All rights reserved.

This publication may be reproduced in whole or in part for non-commercial purposes as long as the Shenzhen Huatongwei International Inspection Co., Ltd is acknowledged as copyright owner and source of the material. Shenzhen Huatongwei International Inspection Co., Ltd takes no responsibility for and will not assume liability for damages resulting from the reader's interpretation of the reproduced material due to its placement and context.

Test item description: PlugLink 500 Wireless "N" Adapter

Trade Mark: /

Model/Type reference.....: PL9571-WAP

Operation Frequency.....: From 2MHz to 70MHz

Listed Models: /

Result.....: **Positive**

TEST REPORT

Test Report No. :	TRE1209009502	Feb 19, 2013
		Date of issue

Equipment under Test : PlugLink 500 Wireless "N" Adapter

Model /Type : PL9571-WAP

Listed Models : /

Applicant : ASOKA Shenzhen Limited.

Address : Room 1701,17/F., Fiyta Hi Tech Building, Gao-Xin Rd, South, Shenzhen , P R China

Manufacturer : Asoka USA Corporation

Address : 2620 Augustine Drive Suite 230,Santa Clara City,CA 95054

Test Result according to the standards on page 4:	Positive
--	-----------------

The test report merely corresponds to the test sample.
 It is not permitted to copy extracts of these test result without the written permission of the test laboratory.

Contents

1.	<u>TEST STANDARDS</u>	<u>4</u>
2.	<u>SUMMARY</u>	<u>5</u>
2.1.	General Remarks	5
2.2.	Equipment Under Test	5
2.3.	Short description of the Equipment under Test (EUT)	5
2.4.	EUT operation mode	5
2.5.	Related Submittal(s) / Grant (s)	5
2.6.	Modifications	5
2.7.	Configuration of Tested System	6
2.8.	Product Information	6
3.	<u>TEST ENVIRONMENT.....</u>	<u>7</u>
3.1.	Address of the test laboratory	7
3.2.	Test Facility	7
3.3.	Environmental conditions	8
3.4.	Statement of the measurement uncertainty	8
3.5.	Equipments Used during the Test	8
4.	<u>TEST CONDITIONS AND RESULTS.....</u>	<u>10</u>
4.1.	Conducted Emissions Test	10
4.2.	Radiated Emission Test	16
5.	<u>TEST SETUP PHOTOS OF THE EUT</u>	<u>22</u>

1. TEST STANDARDS

The tests were performed according to following standards:

[47 CFR FCC Part 15 Subpart B](#) - Unintentional Radiators

[ANSI C63.4: 2009](#) – American National Standard for Methods of Measurement of Radio-Noise Emissions from Low-Voltage Electrical and Electronic Equipment in the Range of 9 kHz to 40GHz

2. SUMMARY

2.1. General Remarks

Date of receipt of test sample	:	Sep 25, 2012
Testing commenced on	:	Sep 25, 2012
Testing concluded on	:	Feb 19, 2013

2.2. Equipment Under Test

Power supply system utilised

Power supply voltage	:	<input checked="" type="radio"/> 120V / 60 Hz	<input type="radio"/> 115V / 60Hz
		<input type="radio"/> 12 V DC	<input type="radio"/> 24 V DC
		<input type="radio"/> Other (specified in blank below)	

/

2.3. Short description of the Equipment under Test (EUT)

The EUT PlugLink 500 Wireless "N" Adapter is an In-House BPL device.

For more details, refer to the user's manual of the EUT.

Sample Type: Prototype

2.4. EUT operation mode

The EUT has been tested under typical operating condition.

2.5. Related Submittal(s) / Grant (s)

This submittal(s) (test report) is intended for FCC ID: **T37PL9571-WAP** filing to comply with the FCC Part 15, Subpart B Rules.

2.6. Modifications

No modifications were implemented to meet testing criteria.

2.7. Configuration of Tested System

Configuration of Tested System

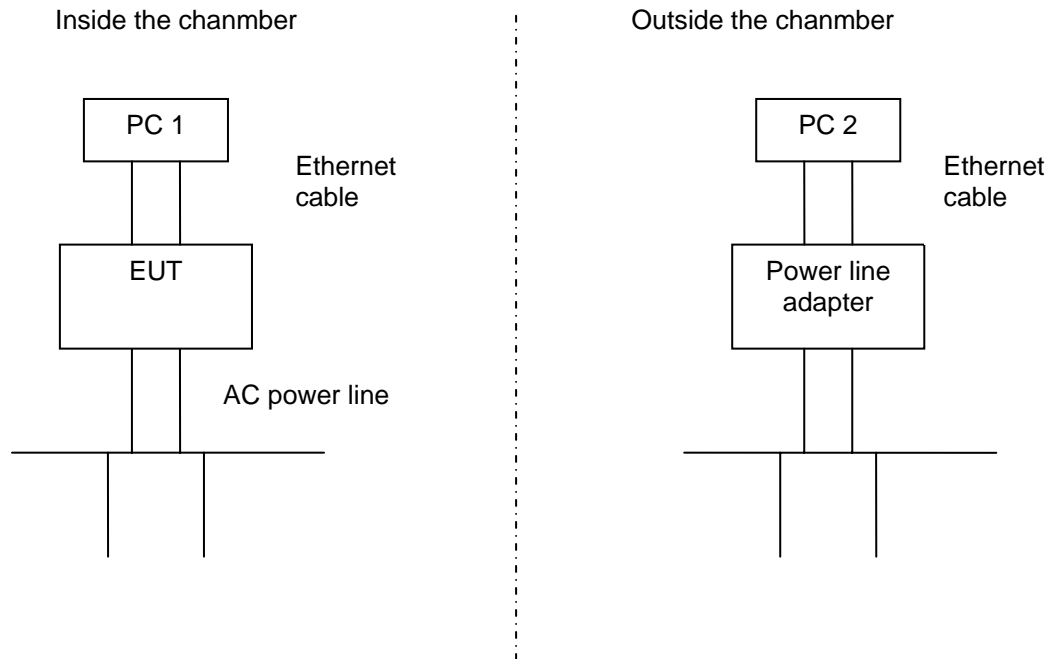

Equipment Used in Tested System

No.	Equipment	Manufacturer	Model No.	Serial No.	Notes
1	PC	DELL	DIMENSION E520	1RNN42X	
2	Notebook PC	DELL	D600	CN-0X2034-48643-428-1379	
3	PlugLink 500 Wireless "N" Adapter	ASOKA	PL9571-WAP	/	

2.8. Product Information

As the product operation frequency band from 2MHz to 70MHz, we choose two products to test conducted emission for operation difference frequencies, the two products PCB layouts and hardware are the same and only software regulates the operating range. While use product 3 which operation frequency band from 2MHz to 70MHz for radiated emission.

Product 1:

Series Number: Y12095000231
 Operation frequency: 2MHz-30MHz;

Product 2:

Series Number: Y12095000152
 Operation frequency: 30MHz-70MHz;

Product 3:

Series Number: Y12095000205
 Operation frequency: 2MHz-70MHz;

3. TEST ENVIRONMENT

3.1. Address of the test laboratory

Shenzhen Huatongwei International Inspection Co., Ltd
Keji Nan No.12 Road, Hi-tech Park, Shenzhen, China
Phone: 86-755-26715686 Fax: 86-755-26748089

The sites are constructed in conformance with the requirements of ANSI C63.7, ANSI C63.4 (2009) and CISPR Publication 22.

3.2. Test Facility

The test facility is recognized, certified, or accredited by the following organizations:

CNAS-Lab Code: L1225

Shenzhen Huatongwei International Inspection Co., Ltd. has been assessed and proved to be in compliance with CNAS-CL01 Accreditation Criteria for Testing and Calibration Laboratories (identical to ISO/IEC 17025: 2005 General Requirements) for the Competence of Testing and Calibration Laboratories, Date of Registration: Mar.01, 2012. Valid time is until Feb. 28, 2015.

A2LA-Lab Cert. No. 2243.01

Shenzhen Huatongwei International Inspection Co., Ltd. EMC Laboratory has been accredited by A2LA for technical competence in the field of electrical testing, and proved to be in compliance with ISO/IEC 17025: 2005 General Requirements for the Competence of Testing and Calibration Laboratories and any additional program requirements in the identified field of testing. Valid time is until Sep. 30, 2013.

FCC-Registration No.: 662850

Shenzhen Huatongwei International Inspection Co., Ltd. EMC Laboratory has been registered and fully described in a report filed with the FCC (Federal Communications Commission). The acceptance letter from the FCC is maintained in our files. Registration 662850, Renewal date Jun. 01, 2012, valid time is until Jun. 01, 2015.

IC-Registration No.: 5377A

The 3m Alternate Test Site of Shenzhen Huatongwei International Inspection Co., Ltd. has been registered by Certification and Engineering Bureau of Industry Canada for the performance of radiated measurements with Registration No. 5377A on Jan. 25, 2011, valid time is until Jan. 24, 2014.

ACA

Shenzhen Huatongwei International Inspection Co., Ltd. EMC Laboratory can also perform testing for the Australian C-Tick mark as a result of our A2LA accreditation.

NEMKO-Aut. No.: ELA125

Shenzhen Huatongwei International Inspection Co., Ltd. has been assessed the quality assurance system, the testing facilities, qualifications and testing practices of the relevant parts of the organization. The quality assurance system of the Laboratory has been validated against ISO/IEC 17025 or equivalent. The laboratory also fulfils the conditions described in Nemko Document NLA-10, the authorization is valid through Jul. 07, 2013.

VCCI

The 3m Semi-anechoic chamber (12.2m×7.95m×6.7m) and Shielded Room (8m×4m×3m) of Shenzhen Huatongwei International Inspection Co., Ltd. has been registered in accordance with the Regulations for Voluntary Control Measures with Registration No.: G-292. Date of Registration: Dec. 24, 2010. Valid time is until Dec. 23, 2013.

Main Ports Conducted Interference Measurement of Shenzhen Huatongwei International Inspection Co., Ltd. has been registered in accordance with the Regulations for Voluntary Control Measures with Registration No.: C-2726. Date of Registration: Dec. 20, 2009. Valid time is until Dec. 19, 2012.

Telecommunication Ports Conducted Interference Measurement of Shenzhen Huatongwei International Inspection Co., Ltd. has been registered in accordance with the Regulations for Voluntary Control Measures with Registration No.: T-1837. Date of Registration: May 07, 2010. Valid time is until May 06, 2013.

DNV

Shenzhen Huatongwei International Inspection Co., Ltd. has been found to comply with the requirements of DNV towards subcontractor of EMC and safety testing services in conjunction with the EMC and Low voltage Directives and in the voluntary field. The acceptance is based on a formal quality Audit and follow-ups according to relevant parts of ISO/IEC Guide 17025 (2005), in accordance with the requirements of the DNV Laboratory Quality Manual towards subcontractors. Valid time is until Aug. 24, 2013.

3.3. Environmental conditions

During the measurement the environmental conditions were within the listed ranges:

Temperature:	<u>15-35 ° C</u>
Humidity:	<u>30-60 %</u>
Atmospheric pressure:	<u>950-1050mbar</u>

3.4. Statement of the measurement uncertainty

The data and results referenced in this document are true and accurate. The reader is cautioned that there may be errors within the calibration limits of the equipment and facilities. The measurement uncertainty was calculated for all measurements listed in this test report acc. to CISPR 16 - 4 „Specification for radio disturbance and immunity measuring apparatus and methods – Part 4: Uncertainty in EMC Measurements“ and is documented in the Shenzhen Huatongwei International Inspection Co., Ltd quality system acc. to DIN EN ISO/IEC 17025. Furthermore, component and process variability of devices similar to that tested may result in additional deviation. The manufacturer has the sole responsibility of continued compliance of the device.

Hereafter the best measurement capability for Shenzhen Huatongwei laboratory is reported:

Test	Range	Measurement Uncertainty	Notes
Radiated Emission	30~1000MHz	4.24 dB	(1)
Radiated Emission	1~18GHz	5.16 dB	(1)
Radiated Emission	18-40GHz	5.54 dB	(1)
Conducted Disturbance	0.15~30MHz	3.39 dB	(1)

(1) This uncertainty represents an expanded uncertainty expressed at approximately the 95% confidence level using a coverage factor of k=2.

3.5. Equipments Used during the Test

Conducted Emission					
Item	Test Equipment	Manufacturer	Model No.	Serial No.	Last Cal.
1	EMI TEST RECEIVER	Rohde & Schwarz	ESCI	100106	2012/10/27
2	ARTIFICIAL MAINS	Rohde & Schwarz	ESH2-Z5	100028	2012/10/27
3	PULSE LIMITER	Rohde & Schwarz	ESHSZ2	100044	2012/10/27
4	EMI TEST SOFTWARE	Rohde & Schwarz	ES-K1	N/A	2012/10/27
5	TWO-LINE V-NETWORK	Rohde & Schwarz	ESH3-Z5	100049	2012/10/27

Radiated Emission					
Item	Test Equipment	Manufacturer	Model No.	Serial No.	Last Cal.
1	ULTRA-BROADBAND ANTENNA	Rohde & Schwarz	HL562	100015	2012/10/27
2	EMI TEST RECEIVER	Rohde & Schwarz	ESI 26	100009	2012/10/27
3	RF TEST PANEL	Rohde & Schwarz	TS / RSP	335015/ 0017	2012/10/27
4	TURNTABLE	ETS	2088	2149	2012/10/27
5	ANTENNA MAST	ETS	2075	2346	2012/10/27
6	EMI TEST SOFTWARE	Rohde & Schwarz	ESK1	N/A	2012/10/27
7	HORN ANTENNA	Rohde & Schwarz	HF906	100039	2012/10/27
8	Amplifer	Sonoma	310N	E009-13	2012/10/27
9	JS amplifer	Rohde & Schwarz	JS4-00101800-28-5A	F201504	2012/10/27
10	High pass filter	Compliance Direction systems	BSU-6	34202	2012/10/27

The calibration interval was one year.

4. TEST CONDITIONS AND RESULTS

4.1. Conducted Emissions Test

TEST CONFIGURATION

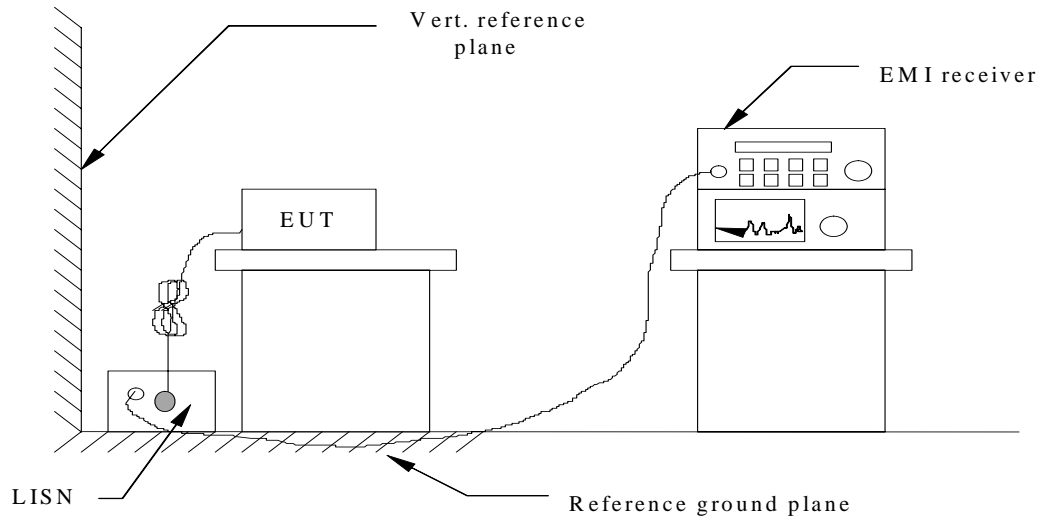

TEST PROCEDURE

- 1 The equipment was set up as per the test configuration to simulate typical actual usage per the user's manual. The EUT is a tabletop system, a wooden table with a height of 0.8 meters is used and is placed on the ground plane as per ANSI C63.4-2009.
- 2 Support equipment, if needed, was placed as per ANSI C63.4-2009.
- 3 All I/O cables were positioned to simulate typical actual usage as per ANSI C63.4-2009.
- 4 The EUT received AC120V/60Hz power through a Line Impedance Stabilization Network (LISN) which supplied power source and was grounded to the ground plane.
- 5 All support equipments received AC power from a second LISN, if any.
- 6 The EUT test program was started. Emissions were measured on each current carrying line of the EUT using a spectrum Analyzer / Receiver connected to the LISN powering the EUT. The LISN has two monitoring points: Line 1 (Hot Side) and Line 2 (Neutral Side). Two scans were taken: one with Line 1 connected to Analyzer / Receiver and Line 2 connected to a 50 ohm load; the second scan had Line 1 connected to a 50 ohm load and Line 2 connected to the Analyzer / Receiver.
- 7 Analyzer / Receiver scanned from 150 KHz to 30MHz for emissions in each of the test modes.
- 8 During the above scans, the emissions were maximized by cable manipulation.

CONDUCTED POWER LINE EMISSION LIMIT

For unintentional device, according to § 15.107(a) Line Conducted Emission Limits is as following :

Frequency (MHz)	Maximum RF Line Voltage (dB μ V)			
	CLASS A		CLASS B	
	Q.P.	Ave.	Q.P.	Ave.
0.15 - 0.50	79	66	66-56*	56-46*
0.50 - 5.00	73	60	56	46
5.00 - 30.0	73	60	60	50

For unintentional device, according to § 15.107(c) Line Conducted Emission Limits is as following :

Frequency (KHz)	Maximum RF Line Voltage	
535-1705	1000 μ V	60dB μ V

For In-House BPL devices operating as unintentional radiators below 30 MHz, the conducted emissions shall be measured in the 535 – 1705 kHz band as specified in Section 15.107(c). For In- House BPL devices operating as unintentional radiators above 30 MHz, the conducted emissions shall be measured as specified in Section 15.107(a).

TEST CONDITION

The data rate was set at the maximum rate used by the EUT, and the operating frequency of the EUT as unintentional radiator was divided into two frequency band, blow 30MHz and above 30MHz.

TEST RESULTS

Operating frequency blow 30MHz

SCAN TABLE: "Voltage (9K-30M) FIN"
 Short Description: 150K-30M Voltage

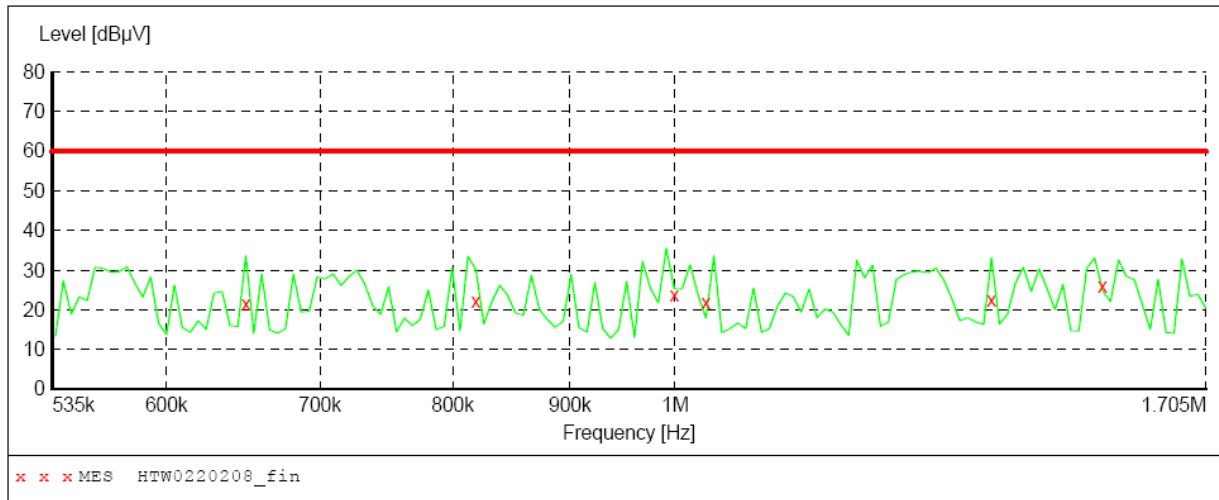

MEASUREMENT RESULT: "HTW0220208_fin"

2/20/2013 4:36PM

Frequency MHz	Level dBµV	Transd dB	Limit dBµV	Margin dB	Detector	Line	PE
0.649868	21.50	10.1	60	38.5	QP	L1	GND
0.818805	22.10	10.1	60	37.9	QP	L1	GND
0.999299	23.70	10.2	60	36.3	QP	L1	GND
1.031660	21.90	10.2	60	38.1	QP	L1	GND
1.374418	22.40	10.2	60	37.6	QP	L1	GND
1.536614	26.00	10.2	60	34.0	QP	L1	GND

SCAN TABLE: "Voltage (9K-30M) FIN"

Short Description: 150K-30M Voltage

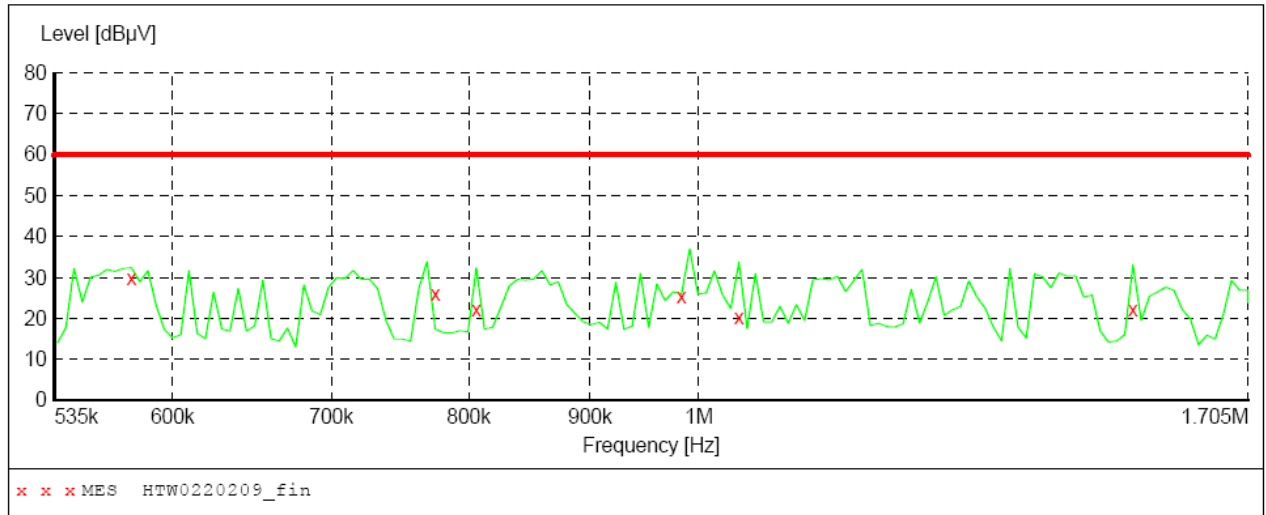

MEASUREMENT RESULT: "HTW0220209_fin"

2/20/2013 4:41PM

Frequency MHz	Level dBµV	Transd dB	Limit dBµV	Margin dB	Detector	Line	PE
0.576657	29.90	10.1	60	30.1	QP	N	GND
0.774383	25.90	10.1	60	34.1	QP	N	GND
0.805866	22.30	10.1	60	37.7	QP	N	GND
0.983500	25.40	10.2	60	34.6	QP	N	GND
1.039913	20.40	10.2	60	39.6	QP	N	GND
1.524419	22.00	10.2	60	38.0	QP	N	GND

Operating frequency Above 30MHz

SCAN TABLE: "Voltage (9K-30M) FIN"
 Short Description: 150K-30M Voltage

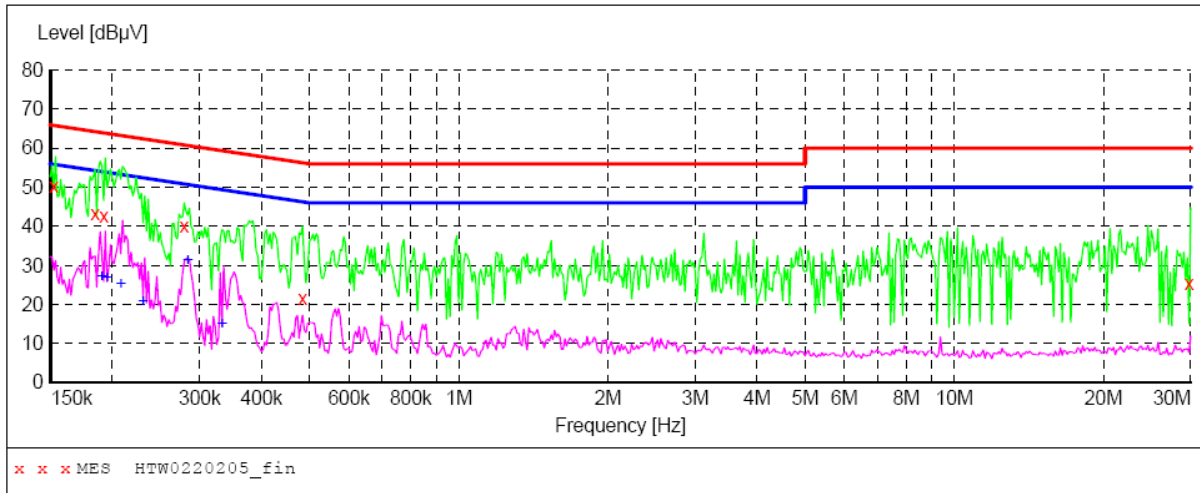

MEASUREMENT RESULT: "HTW0220205_fin"

2/20/2013 4:13PM

Frequency MHz	Level dBµV	Transd dB	Limit dBµV	Margin dB	Detector	Line	PE
0.152400	50.20	10.1	66	15.7	QP	L1	GND
0.184524	43.10	10.1	64	21.2	QP	L1	GND
0.192020	42.60	10.1	64	21.3	QP	L1	GND
0.279256	40.10	10.1	61	20.7	QP	L1	GND
0.483931	21.40	10.1	56	34.9	QP	L1	GND
29.777240	25.50	11.0	60	34.5	QP	L1	GND

MEASUREMENT RESULT: "HTW0220205_fin2"

2/20/2013 4:13PM

Frequency MHz	Level dBµV	Transd dB	Limit dBµV	Margin dB	Detector	Line	PE
0.190500	27.20	10.1	54	26.8	AV	L1	GND
0.195105	26.80	10.1	54	27.0	AV	L1	GND
0.207950	25.30	10.1	53	28.0	AV	L1	GND
0.230650	21.00	10.1	52	31.4	AV	L1	GND
0.283742	31.40	10.1	51	19.3	AV	L1	GND
0.332770	15.10	10.1	49	34.3	AV	L1	GND

SCAN TABLE: "Voltage (9K-30M) FIN"
 Short Description: 150K-30M Voltage

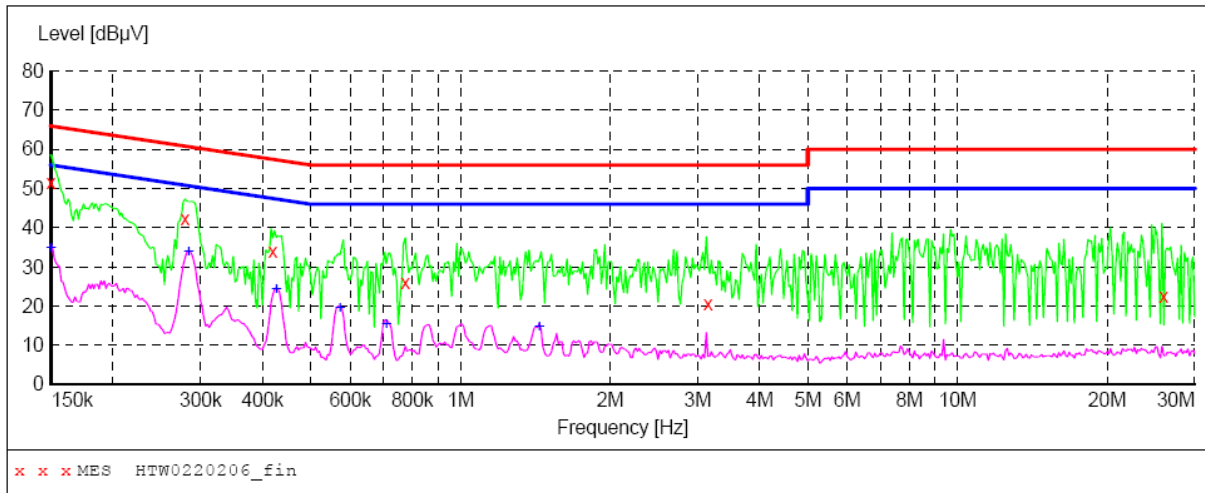

MEASUREMENT RESULT: "HTW0220206_fin"

2/20/2013 4:21PM

Frequency MHz	Level dBµV	Transd dB	Limit dBµV	Margin dB	Detector	Line	PE
0.150000	51.40	10.1	66	14.6	QP	N	GND
0.279256	42.40	10.1	61	18.4	QP	N	GND
0.419270	33.90	10.1	58	23.6	QP	N	GND
0.774386	25.90	10.1	56	30.1	QP	N	GND
3.147850	20.70	10.2	56	35.3	QP	N	GND
26.004918	22.60	11.0	60	37.4	QP	N	GND

MEASUREMENT RESULT: "HTW0220206_fin2"

2/20/2013 4:21PM

Frequency MHz	Level dBµV	Transd dB	Limit dBµV	Margin dB	Detector	Line	PE
0.150000	35.00	10.1	56	21.0	AV	N	GND
0.283742	34.10	10.1	51	16.6	AV	N	GND
0.426011	24.40	10.1	47	22.9	AV	N	GND
0.572080	19.50	10.1	46	26.5	AV	N	GND
0.709400	15.60	10.1	46	30.4	AV	N	GND
1.441722	14.80	10.2	46	31.2	AV	N	GND

Remark:

- (1) Measuring frequencies from 0.15 MHz to the 30 MHz.
- (2) Data of measurement within this frequency range shown "---" in the table above means the reading of emissions are attenuated more than 20dB below the permissible limits or the field strength is too small to be measured.
- (3) The IF bandwidth of EMI Test Receiver was 9KHz for measuring from 0.15 MHz to 30MHz

4.2. Radiated Emission Test

TEST CONFIGURATION

- a) Radiated Emission Test Set-Up, Frequency below 1000MHz

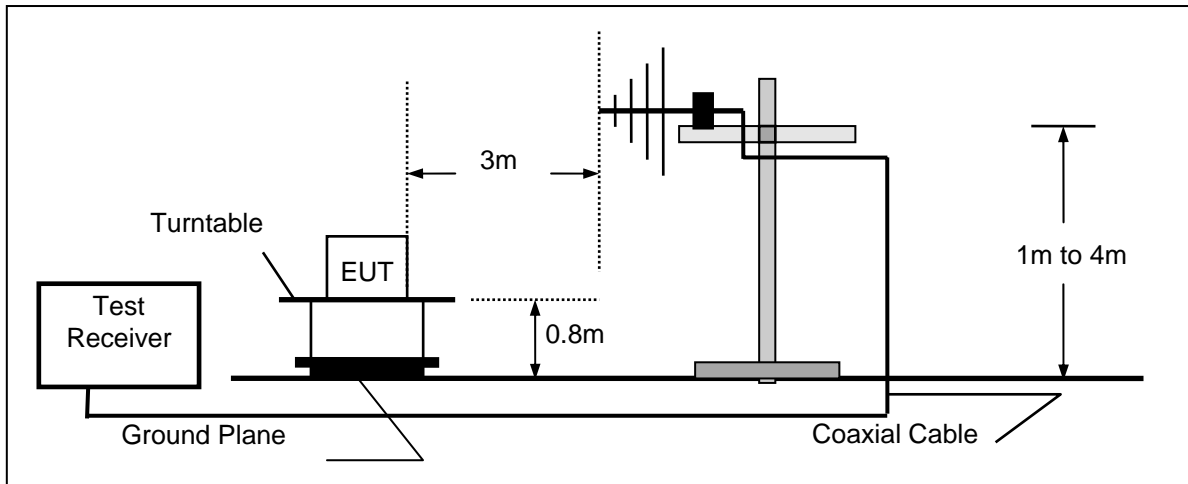

- b) Radiated Emission Test Set-Up, Frequency above 1000MHz

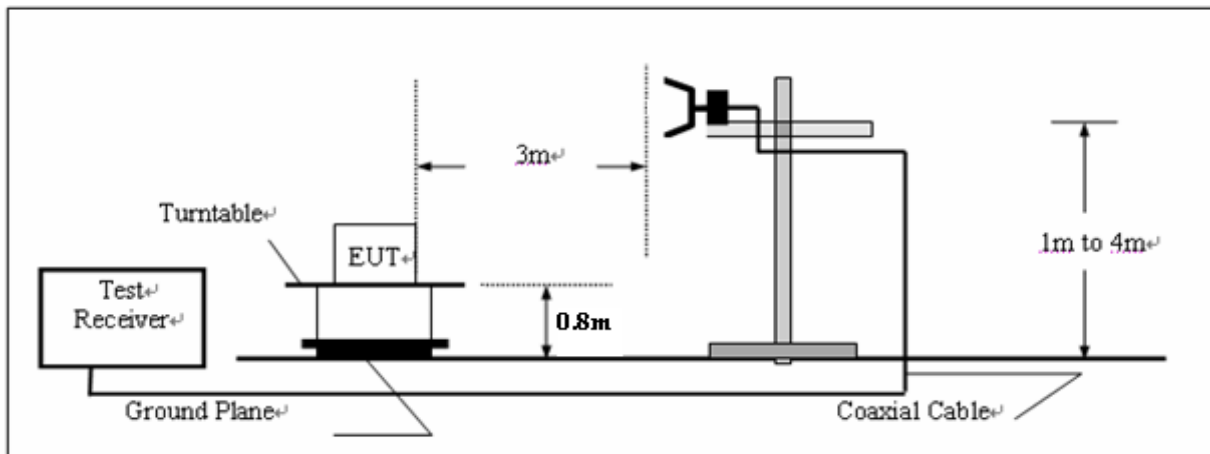

TEST PROCEDURE

1. The EUT is placed on a turntable, which is 0.8m above ground plane.
2. The turntable shall be rotated for 360 degrees to determine the position of maximum emission level.
3. EUT is set 3m away from the receiving antenna, which is varied from 1m to 4m to find out the highest emissions.
4. Maximum procedure was performed on the six highest emissions to ensure EUT compliance.
5. And also, each emission was to be maximized by changing the polarization of receiving antenna both horizontal and vertical.
6. Repeat above procedures until the measurements for all frequencies are complete.

FIELD STRENGTH CALCULATION

The field strength is calculated by adding the Antenna Factor and Cable Factor and subtracting the Amplifier Gain and Duty Cycle Correction Factor (if any) from the measured reading. The basic equation with a sample calculation is as follows:

$$FS = RA + AF + CL - AG$$

Where FS = Field Strength	CL = Cable Attenuation Factor (Cable Loss)
RA = Reading Amplitude	AG = Amplifier Gain
AF = Antenna Factor	

For example

Frequency (MHz)	FS (dBµV/m)	RA (dBµV/m)	AF (dB)	CL (dB)	AG (dB)	Transd (dB)
300.00	40	58.1	12.2	1.6	31.90	-18.1

$$Transd=AF +CL-AG$$

RADIATION LIMIT

For unintentional device, according to § 15.109(a), except for Class A digital devices, the field strength of radiated emissions from unintentional radiators at a distance of 3 meters shall not exceed the following values:

Frequency (MHz)	Distance (Meters)	Radiated (dBµV/m)	Radiated (µV/m)
30-88	3	40.0	100
88-216	3	43.5	150
216-960	3	46.0	200
Above 960	3	54.0	500

For intentional device, according to § 15.209(a), the general requirement of field strength of radiated emissions from intentional radiators at a distance of 3 meters shall not exceed the above table.

TEST CONDITION

The data rate was set at the maximum rate used by the EUT.

The highest fundamental frequency of the EUT is 200MHz, according to § 15.33(a), the radiated emission test was performed within the frequency band 30MHz – 2000MHz. The unintentional operating frequency range is 2MHz – 70MHz.

TEST RESULTS

SCAN TABLE: "test Field(30M-1G)QP"

Short Description: Field Strength(30M-1G)
 Start Stop Step Detector Meas. IF Transducer
 Frequency Frequency Width Time Bandw.
 30.0 MHz 1.0 GHz 60.0 kHz QuasiPeak 1.0 s 120 kHz HL562

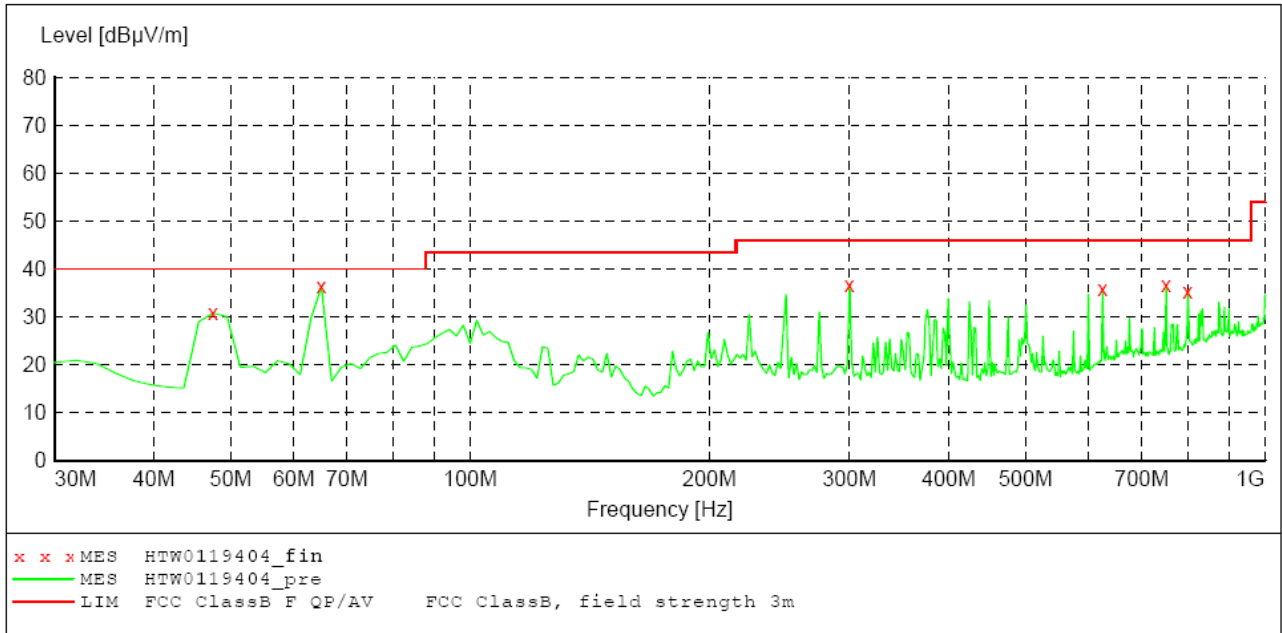

MEASUREMENT RESULT: "HTW0119404_fin"

1/19/2013 4:55PM

Frequency MHz	Level dBµV/m	Transd dB	Limit dBµV/m	Margin dB	Det.	Height cm	Azimuth deg	Polarization
47.494990	30.80	-21.3	40.0	9.2	QP	300.0	291.00	HORIZONTAL
64.989980	36.30	-24.2	40.0	3.7	QP	300.0	320.00	HORIZONTAL
300.200401	36.80	-17.7	46.0	9.2	QP	100.0	179.00	HORIZONTAL
624.829659	35.70	-12.2	46.0	10.3	QP	100.0	203.00	HORIZONTAL
751.182365	36.60	-11.2	46.0	9.4	QP	100.0	135.00	HORIZONTAL
799.779559	35.40	-9.8	46.0	10.6	QP	100.0	227.00	HORIZONTAL

SCAN TABLE: "test Field(30M-1G)QP"

Short Description:		Field Strength(30M-1G)					
Start	Stop	Step	Detector	Meas. Time	IF Bandw.	Transducer	
Frequency	Frequency	Width					
30.0 MHz	1.0 GHz	60.0 kHz	QuasiPeak	1.0 s	120 kHz	HL562	

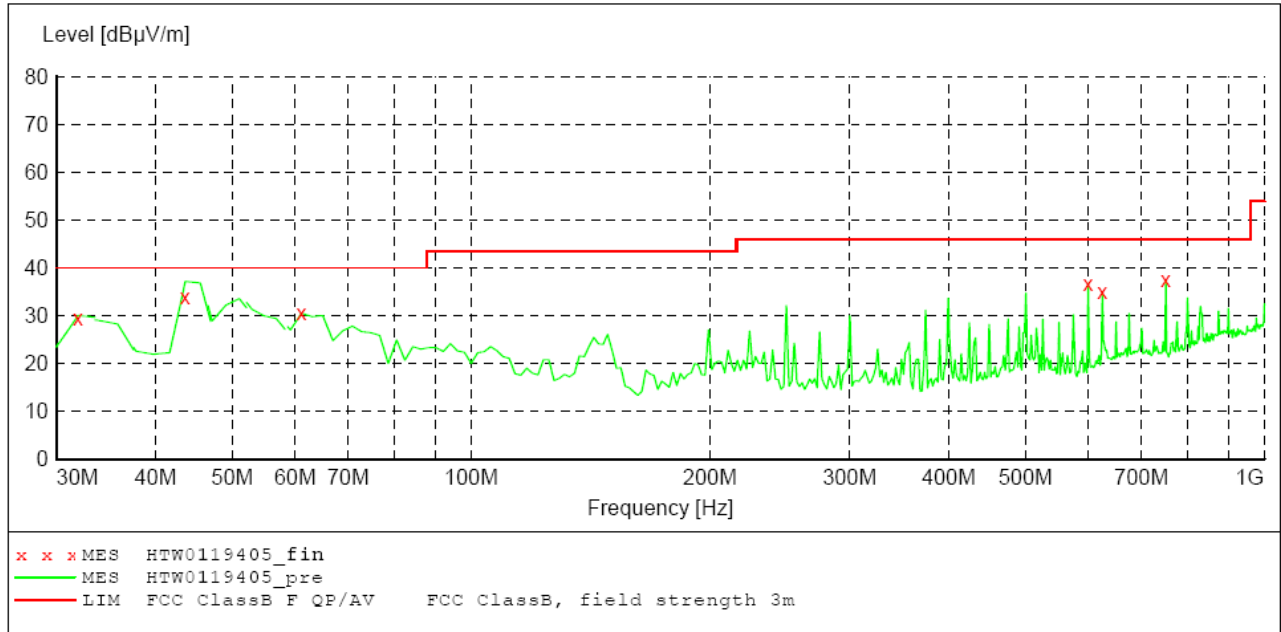

MEASUREMENT RESULT: "HTW0119405_fin"

1/19/2013 4:57PM

Frequency MHz	Level dBµV/m	Transd dB	Limit dBµV/m	Margin dB	Det.	Height cm	Azimuth deg	Polarization
31.943888	30.00	-12.5	40.0	10.0	QP	100.0	173.00	VERTICAL
43.607214	35.20	-18.8	40.0	4.8	QP	100.0	29.00	VERTICAL
61.102204	30.50	-25.1	40.0	9.5	QP	100.0	168.00	VERTICAL
599.559118	36.80	-13.7	46.0	9.2	QP	100.0	221.00	VERTICAL
624.829659	35.00	-12.2	46.0	11.0	QP	100.0	173.00	VERTICAL
751.182365	37.50	-11.2	46.0	8.5	QP	100.0	7.00	VERTICAL

Remark:

- (1) Measuring frequencies from 30 MHz to the 1 GHz.
- (2) Data of measurement within this frequency range shown "---" in the table above means the reading of emissions are attenuated more than 20dB below the permissible limits or the field strength is too small to be measured.
- (3) The IF bandwidth of EMI Test Receiver was 120KHz for measuring from 30 MHz to 1 GHz and 1 MHz for measuring above 1 GHz

Sweep TABLE: "test Field(1G-2G)QP"

Short Description: Field Strength(1G-2G)

Start Frequency	Stop Frequency	Detector	IF Bandw.	Transducer
1.0 GHz	2.0 GHz	MaxPeak	1 MHz	HF906

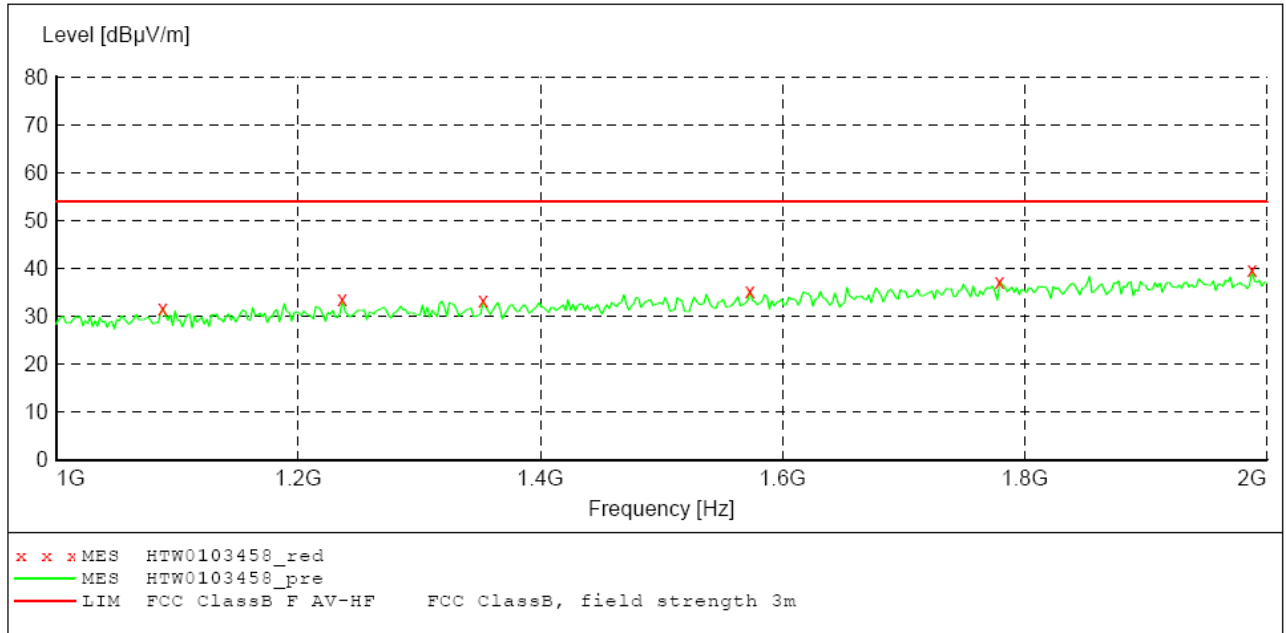

MEASUREMENT RESULT: "HTW0103458_red"

1/03/2013 1:13PM

Frequency MHz	Level dBuV/m	Transd dB	Limit dBuV/m	Margin dB	Det.	Height cm	Azimuth deg	Polarization
1088.176353	31.80	-9.0	54.0	22.2	PK	100.0	129.00	HORIZONTAL
1236.472946	33.50	-7.8	54.0	20.5	PK	100.0	31.00	HORIZONTAL
1352.705411	33.20	-6.9	54.0	20.8	PK	100.0	0.00	HORIZONTAL
1573.146293	35.20	-5.2	54.0	18.8	PK	100.0	125.00	HORIZONTAL
1779.559118	37.30	-3.2	54.0	16.7	PK	100.0	68.00	HORIZONTAL
1987.975952	39.60	-1.5	54.0	14.4	PK	100.0	152.00	HORIZONTAL

Remark:

- (1) Measuring frequencies from 1 GHz to the 2 GHz.
- (2) Data of measurement within this frequency range shown "---" in the table above means the reading of emissions are attenuated more than 20dB below the permissible limits or the field strength is too small to be measured.
- (3) The RBW of EMI Test Receiver was 1MHz and the VBW was 3MHz for measuring from 1 GHz to 2 GHz.
- (4) The average measurement was not performed when the peak measured data under the limit of average detection.

Sweep TABLE: "test Field(1G-2G)QP"

Short Description: Field Strength(1G-2G)

Start Frequency	Stop Frequency	Detector	IF Bandw.	Transducer
1.0 GHz	2.0 GHz	MaxPeak	1 MHz	HF906

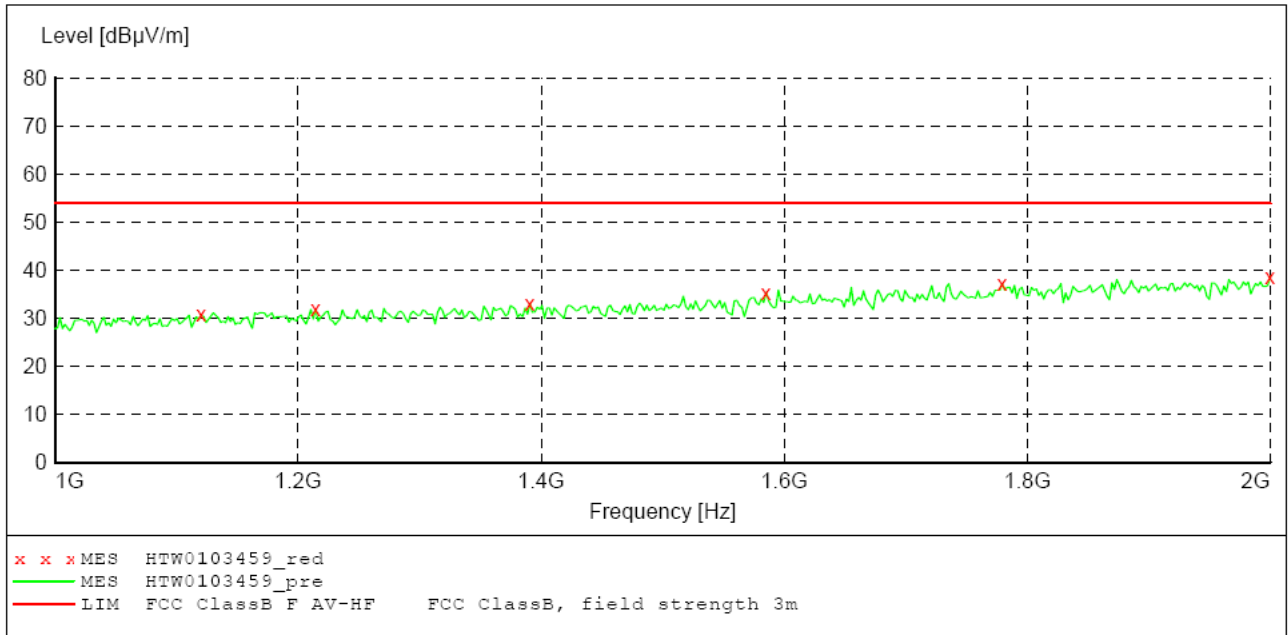

MEASUREMENT RESULT: "HTW0103459_red"

1/03/2011 1:14PM

Frequency MHz	Level dBµV/m	Transd dB	Limit dBµV/m	Margin dB	Det.	Height cm	Azimuth deg	Polarization
1120.240481	30.70	-8.7	54.0	23.3	PK	100.0	51.00	VERTICAL
1214.428858	31.90	-8.0	54.0	22.1	PK	100.0	172.00	VERTICAL
1390.781563	33.10	-6.7	54.0	20.9	PK	100.0	114.00	VERTICAL
1585.170341	35.40	-5.1	54.0	18.6	PK	100.0	7.00	VERTICAL
1779.559118	37.30	-3.2	54.0	16.7	PK	100.0	142.00	VERTICAL
2000.000000	38.70	-1.4	54.0	15.3	PK	100.0	157.00	VERTICAL

Remark:

- (1) Measuring frequencies from 1 GHz to the 2 GHz.
- (2) Data of measurement within this frequency range shown "---" in the table above means the reading of emissions are attenuated more than 20dB below the permissible limits or the field strength is too small to be measured.
- (3) The RBW of EMI Test Receiver was 1MHz and the VBW was 3MHz for measuring from 1 GHz to 2 GHz.
- (4) The average measurement was not performed when the peak measured data under the limit of average detection.

5. Test Setup Photos of the EUT

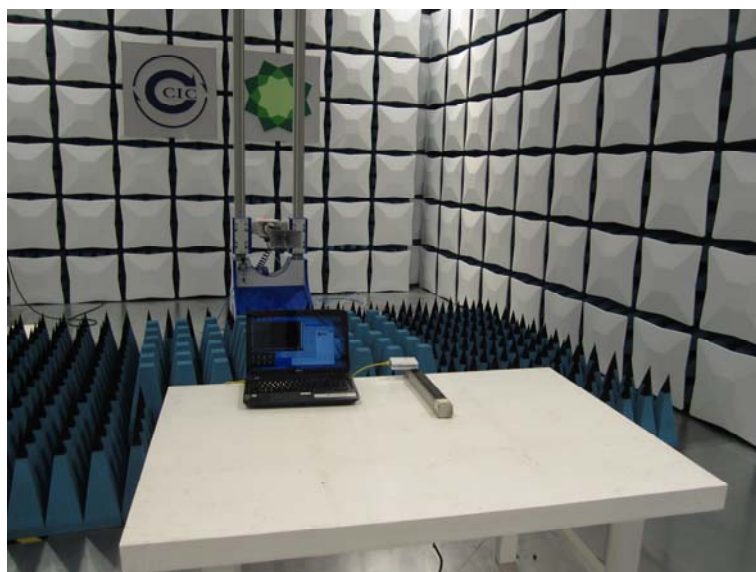

.....End of Report.....