

5

4

3

2

1

D

D

DATE

REVISION

DESCRIPTION

09/27/2007

A

INITIAL RELEASE

C

C

B

B

A

A

ASOKA-USA, CORPORATION

558 Pilgrim Drive, Unit H
Foster City, CA 94044
1-650-286-1700

Title

PSU PLC 200M MODEM

Size
A

Document Number

SCH-80-8660-12

Rev
A

Date: Thursday, September 27, 2007 Sheet 1 of 2

5

4

3

2

1

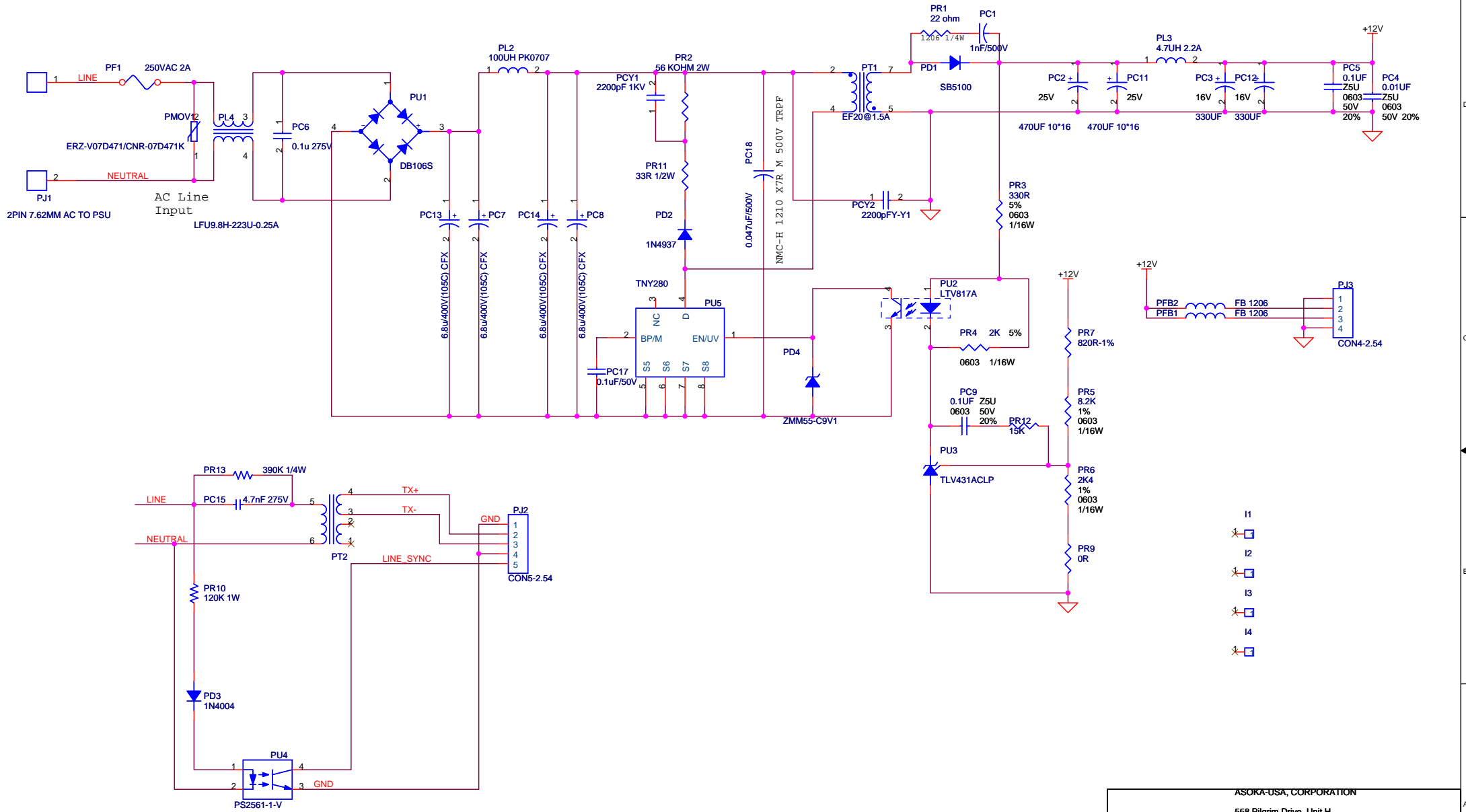

- I1
- I2
- I3
- I4

ASOKA-USA, CORPORATION			
558 Pilgrim Drive, Unit H Foster City, CA 94044 1-650-286-1700			
Title		PSU PLC 200M MODEM	
Size	Document Number	SCH-80-8660-12	Rev
B			A
Date:	Thursday, September 27, 2007	Sheet	2 of 2

DATE	REVISION	DESCRIPTION
11/12/2007	A	INITIAL RELEASE

CONFIDENTIAL

Copyright 2007. Asoka USA Corporation. All Rights Reserved.
 This document contains confidential information of Asoka USA Corporation. In consideration of the receipt of this document, recipient agrees not to reproduce or make this information available in any manner to persons outside the group directly responsible for evaluation of its contents.

ASOKA-USA CORPORATION		
558 PILGRIM DRIVE, UNIT H FOSTER CITY, CA 94404 1-650-286-1700		
Title PLC 200M MODEM WITH WIFI		
Size A	Document Number SCH-80-9560-02	Rev A
Date: Tuesday, April 22, 2008		Sheet 1 of 9

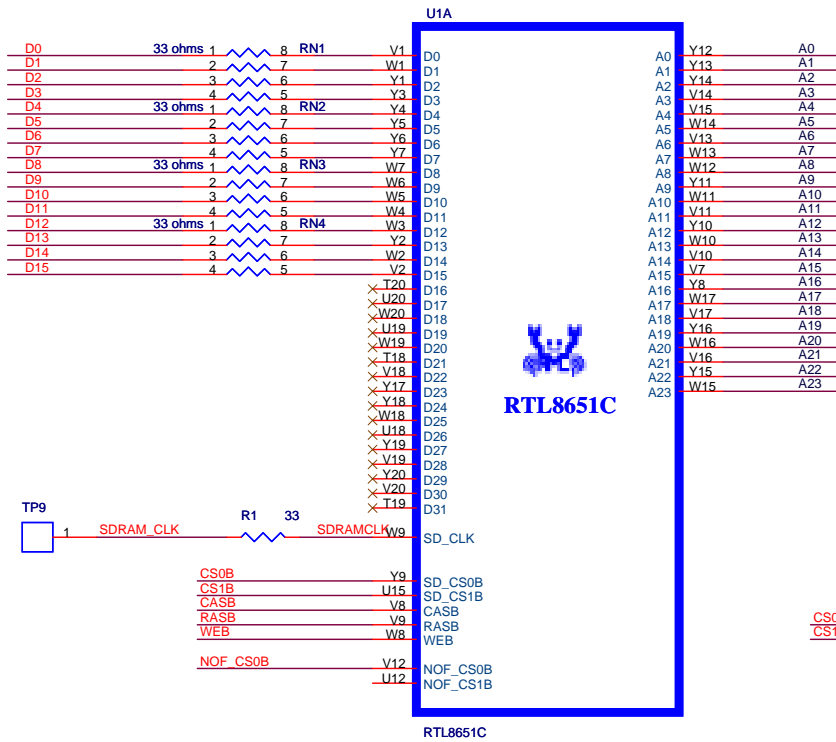

MEMORY

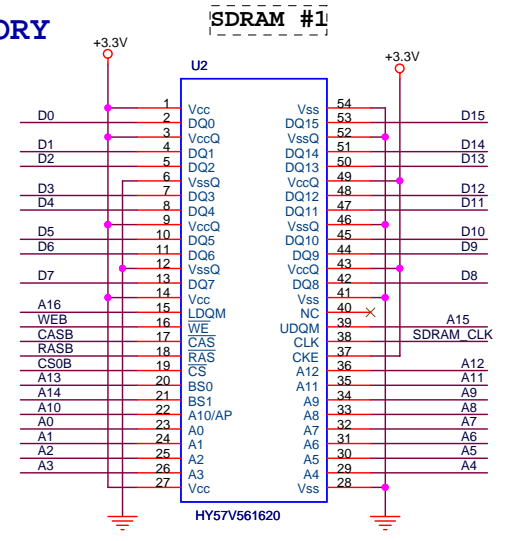

FLASH-0

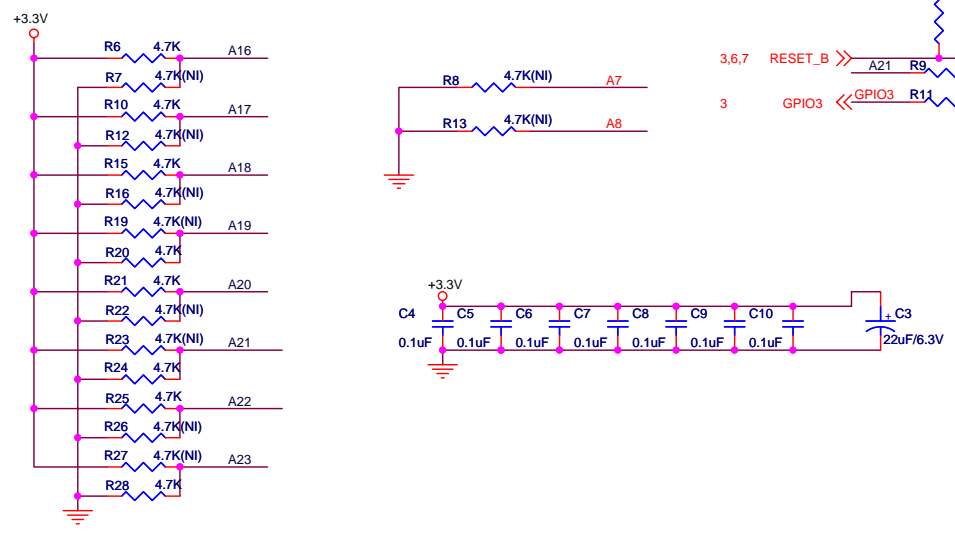
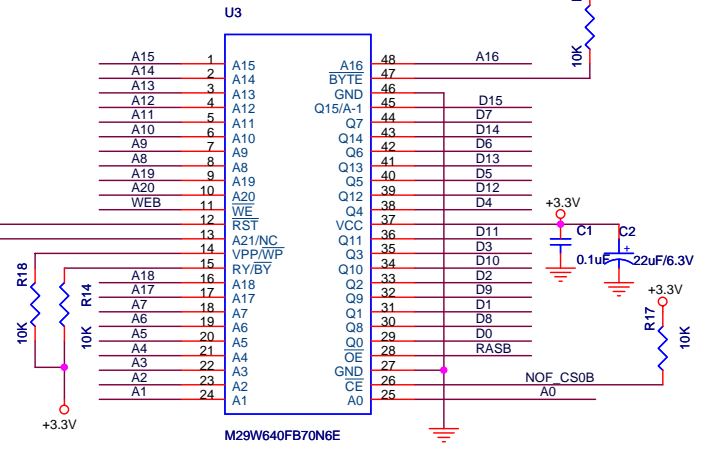

CONFIDENTIAL

Copyright 2007. Asoka USA Corporation. All Rights Reserved.

This document contains confidential information of Asoka USA Corporation. In consideration of the receipt of this document, recipient agrees not to reproduce or make this information available in any manner to persons outside the group directly responsible for evaluation of its contents.

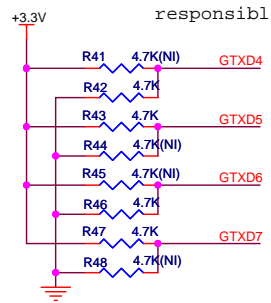
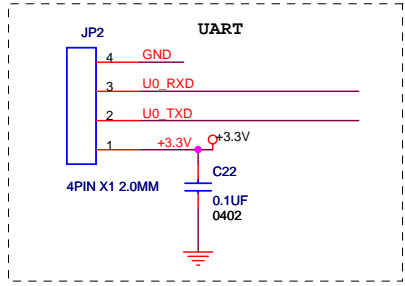
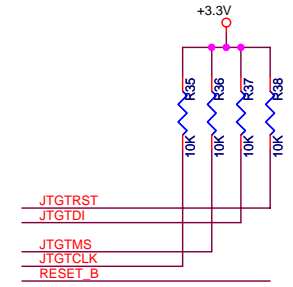
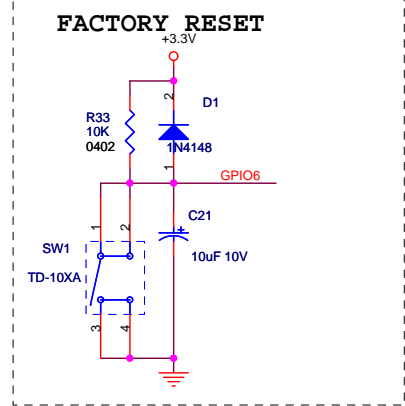
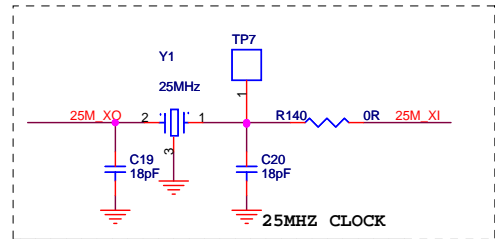
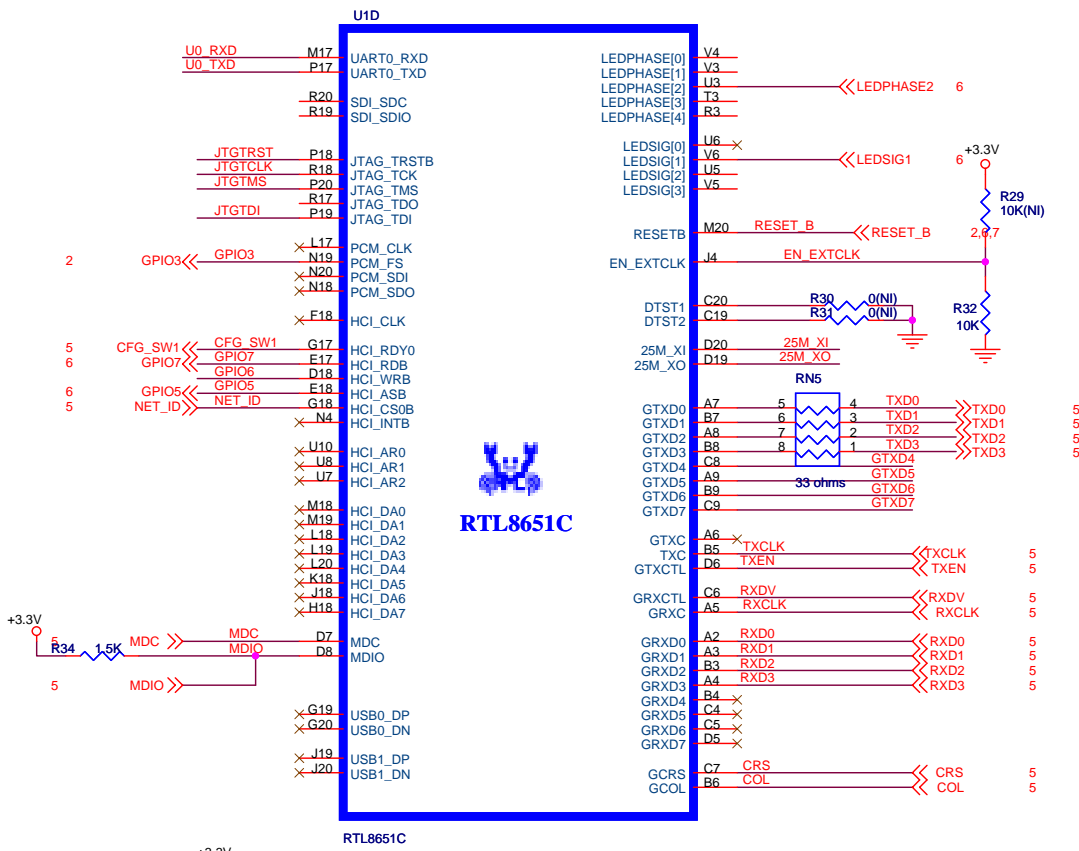

CONFIDENTIAL

Copyright 2007. Asoka USA Corporation. All Rights Reserved. This document contains confidential information of Asoka USA Corporation. In consideration of the receipt of this document, recipient agrees not to reproduce or make this information available in any manner to persons outside the group directly responsible for evaluation of its contents.

ASOKA-USA CORPORATION		
558 PILGRIM DRIVE, UNIT H FOSTER CITY, CA 94404 1-650-286-1700		
Title PLC 200M MODEM WITH WIFI		
Size B	Document Number SCH-80-9560-02	Rev A
Date: Tuesday, April 22, 2008	Sheet 3	of 9

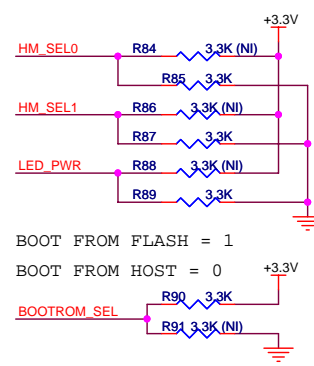
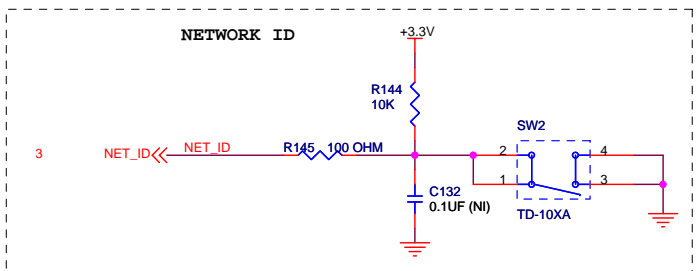
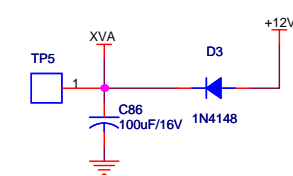
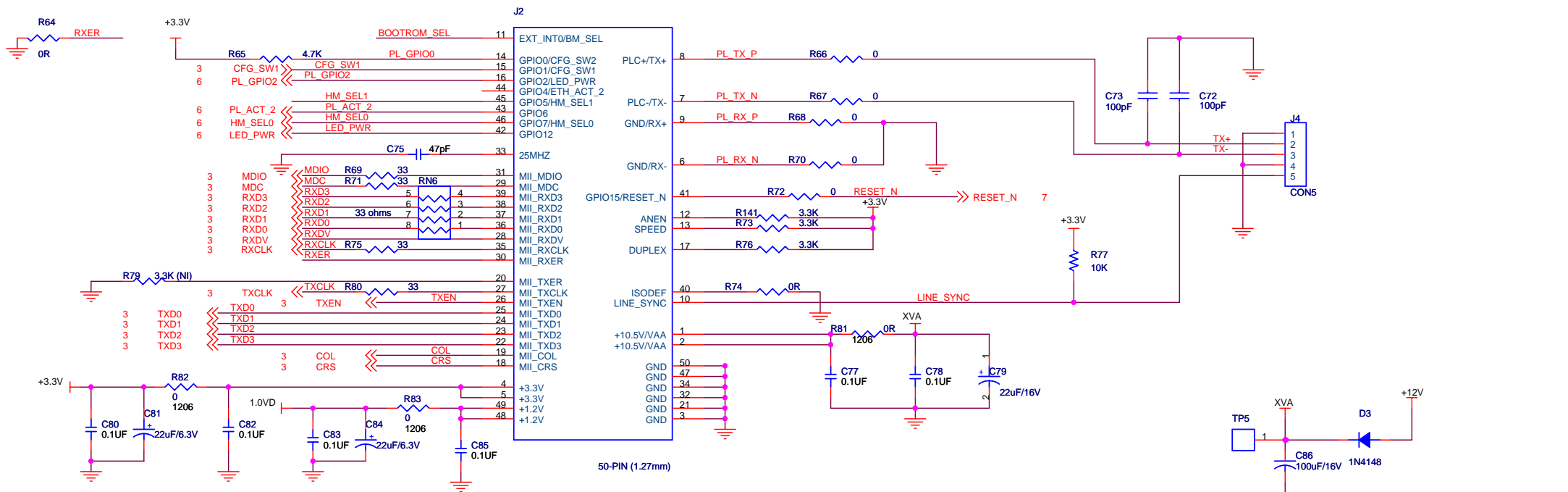

INT6000 INTERFACE MODE SELECT

HM_SEL (1:0)	MODE
00	MII PHY
01	MII MAC
10	NA
11	NA

BOOT FROM FLASH = 1
 BOOT FROM HOST = 0

- I1
- I2
- I3
- I4

CONFIDENTIAL

Copyright 2007. Asoka USA Corporation. All Rights Reserved. This document contains confidential information of Asoka USA Corporation. In consideration of the receipt of this document, recipient agrees not to reproduce or make this information available in any manner to persons outside the group directly responsible for evaluation of its contents.

ASOKA-USA CORPORATION
 558 PILGRIM DRIVE, UNIT H
 FOSTER CITY, CA 94404
 1-650-286-1700

Title: **PLC 200M MODEM WITH WIFI**

Size B Document Number: **SCH-80-9560-02** Rev A

Date: Tuesday, April 22, 2008 Sheet 5 of 9

PLC LED

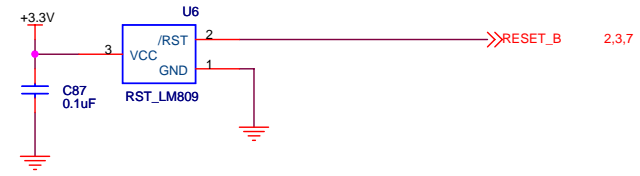
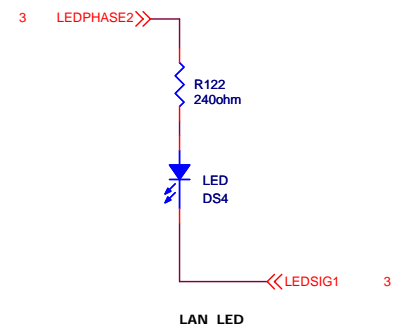
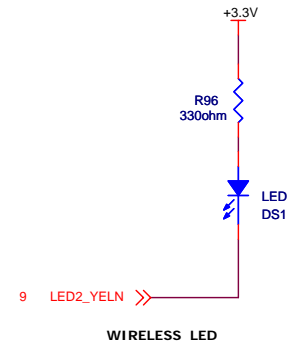
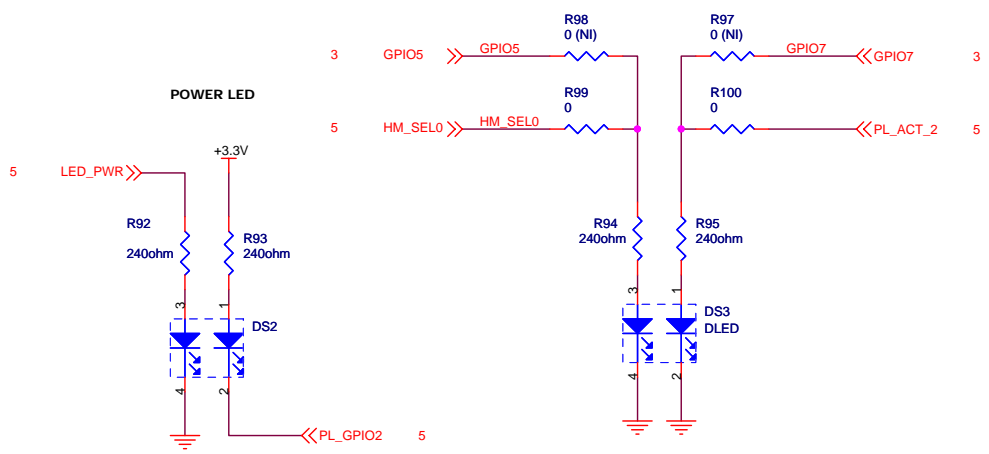

CONFIDENTIAL

Copyright 2007, Asoka USA Corporation. All Rights Reserved. This document contains confidential information of Asoka USA Corporation. In consideration of the receipt of this document, recipient agrees not to reproduce or make this information available in any manner to persons outside the group directly responsible for evaluation of its contents.

ASOKA-USA, CORPORATION			
558 Pilgrim Drive, Unit H Foster City, CA 94044 1-286-1700			
Title		PLC 200M MODEM WITH WIFI	
Size	Document Number	Rev	
B	SCH-80-9560-02	A	
Date:	Tuesday, April 22, 2008	Sheet	6 of 9

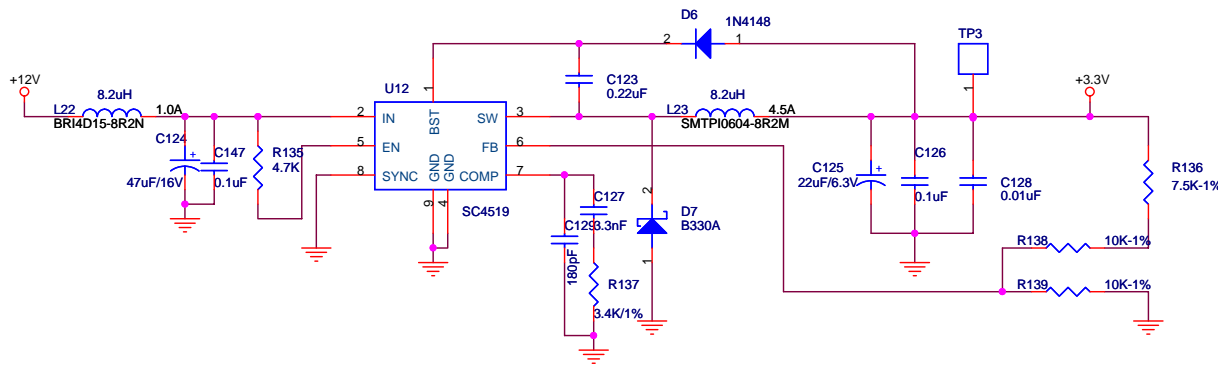
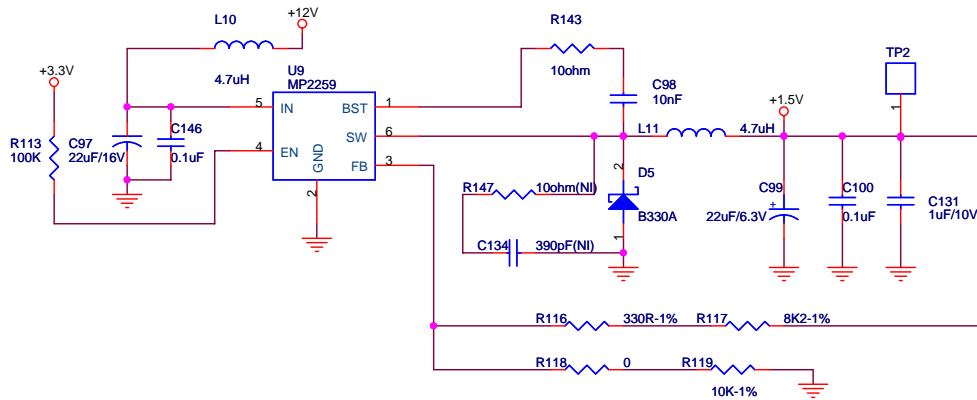
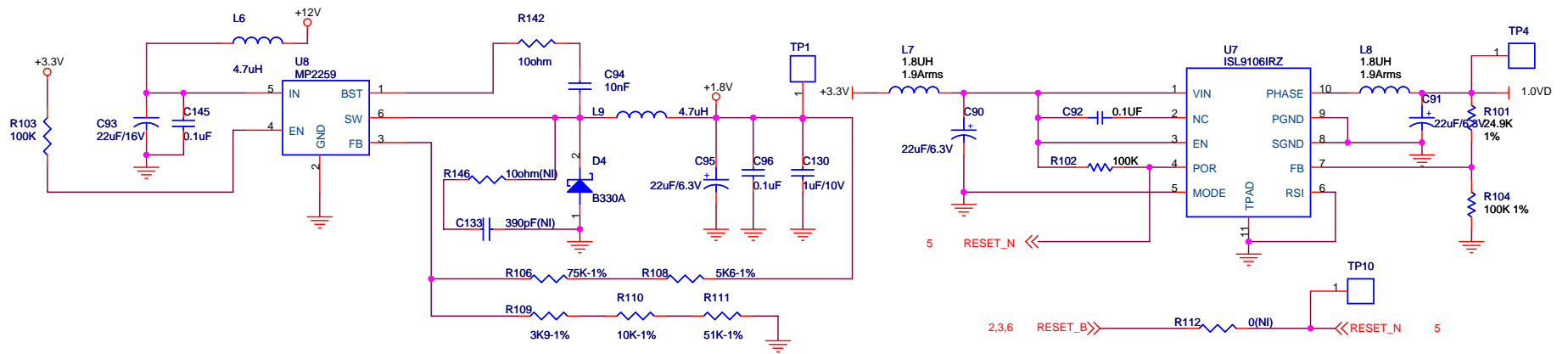

CONFIDENTIAL

Copyright 2007. Asoka USA Corporation. All Rights Reserved. This document contains confidential information of Asoka USA Corporation. In consideration of the receipt of this document, recipient agrees not to reproduce or make this information available in any manner to persons outside the group directly responsible for evaluation of its contents.

Title		
PLC 200M MODEM WITH WIFI		
Size	Document Number	Rev
B	SCH-80-9560-02	A
Date:	Tuesday, April 22, 2008	Sheet 7 of 9

Layout Guide:
Near to the RTL8651C
Chip side

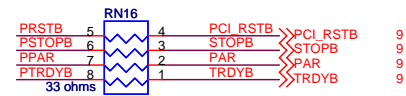
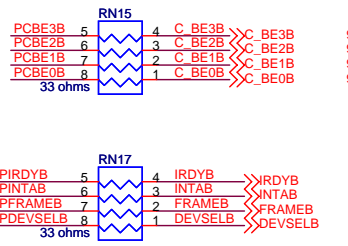
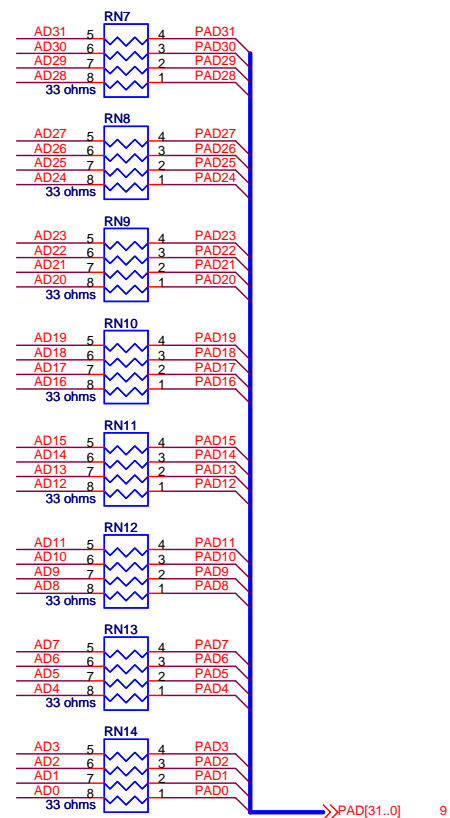
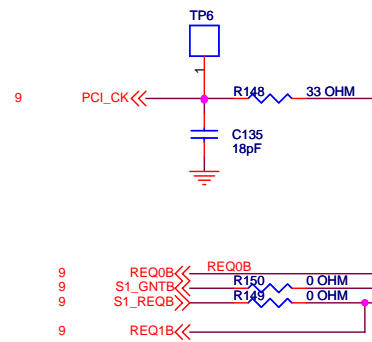
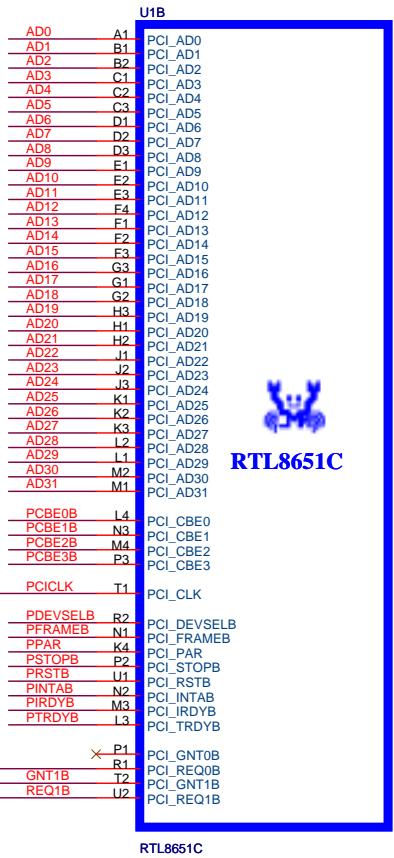

Title		
PLC 200M MODEM WITH WIFI		
Size	Document Number	Rev
B	SCH-80-9560-02	A
Date:	Tuesday, April 22, 2008	Sheet 8 of 9

PCI Slot 1
Mini PCI Slot
(3.3V,33/66MHz,32Bit)

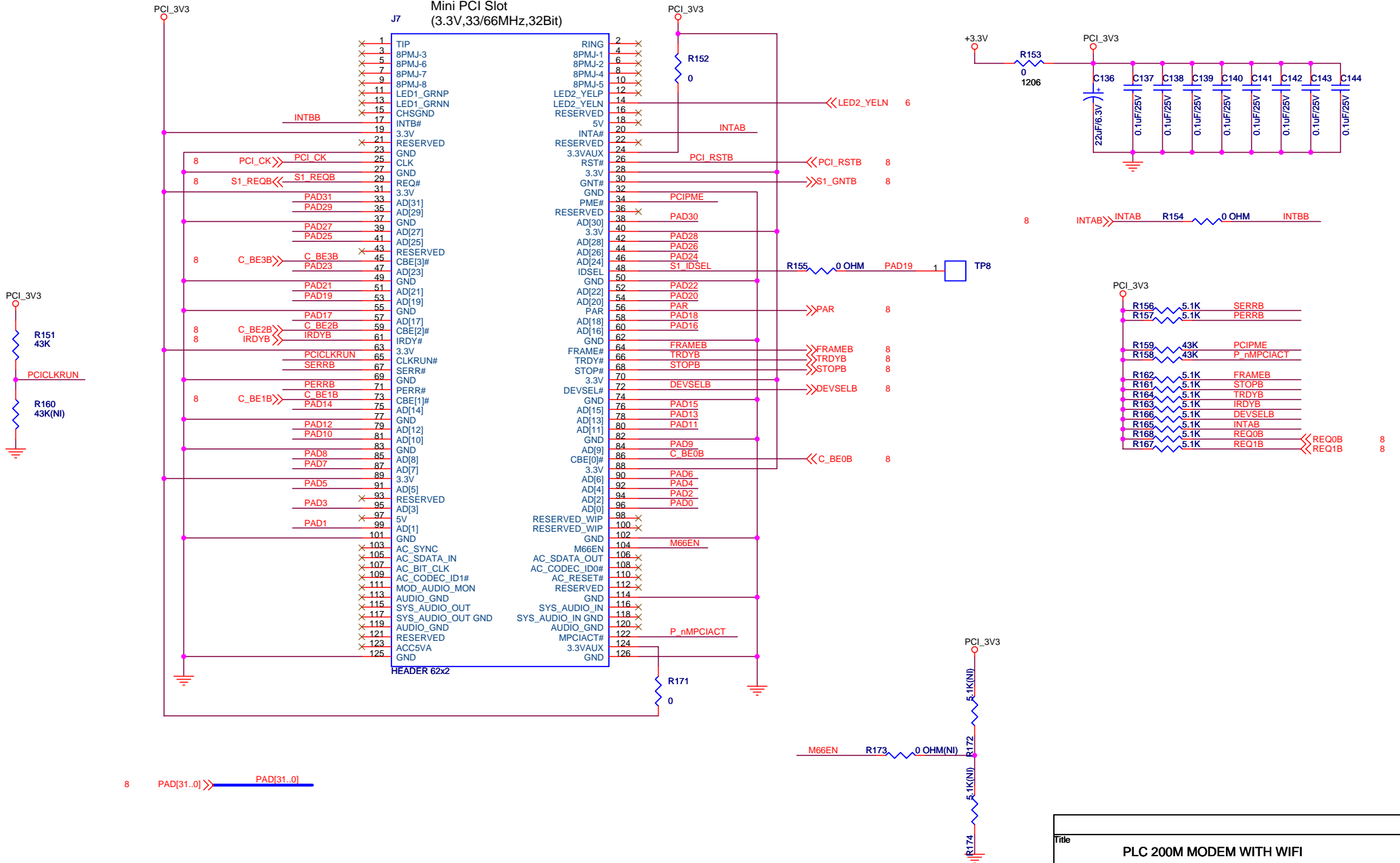

Title		
PLC 200M MODEM WITH WIFI		
Size	Document Number	Rev
B	SCH-80-9560-02	A
Date:	Tuesday, April 22, 2008	Sheet 9 of 9