

TEST REPORT

Applicant Name : YEALINK (XIAMEN) NETWORK TECHNOLOGY CO., LTD.
Address : FCC: 309, 3rd Floor, No.16, Yun Ding North Road, Huli District,
 Xiamen City, Fujian, China
 ISEDC: 309, 3rd Floor, No.16, Yun Ding North Road, Huli
 District Xiamen City Fujian 361008 China (Peoples Republic
 Of)
Report Number : SZNS220328-10962E-RF
FCC ID: T2C-W57R
IC: 10741A-W57R

Test Standard (s)

FCC PART 15D; RSS-GEN ISSUE 5, FEBRUARY 2021 AMENDMENT 2; RSS-213, ISSUE 3,
 MARCH 2015

Sample Description

Product Type: DECT IP Phone
Model No.: W57R
Multiple Model(s) No.: N/A
Trade Mark: **Yealink**
Date Received: 2022/03/28
Report Date: 2022/05/09

Test Result:	Pass*
---------------------	-------

* In the configuration tested, the EUT complied with the standards above.

Prepared and Checked By:

Black Ding

Black Ding
 EMC Engineer

Approved By:

Robert Li

Robert Li
 EMC Engineer

Note: This report may contain data that are not covered by the A2LA accreditation and are marked with an asterisk "*" .

Shenzhen Accurate Technology Co., Ltd. is not responsible for the authenticity of any test data provided by the applicant. Data included from the applicant that may affect test results are marked with an asterisk "**". Customer model name, addresses, names, trademarks etc. are not considered data.

This report cannot be reproduced except in full, without prior written approval of the Company. Unless otherwise stated the results shown in this test report refer only to the sample(s) tested. This report is valid only with a valid digital signature. The digital signature may be available only under the Adobe software above version 7.0.

Shenzhen Accurate Technology Co., Ltd.

1/F., Building A, Changyuan New Material Port, Science & Industry Park, Nanshan District, Shenzhen, Guangdong, P.R. China
 Tel: +86 755-26503290 Fax: +86 755-26503396 Web: www.atc-lab.com

TABLE OF CONTENTS

GENERAL INFORMATION	4
PRODUCT DESCRIPTION FOR EQUIPMENT UNDER TEST (EUT).....	4
OBJECTIVE	4
TEST METHODOLOGY	4
MEASUREMENT UNCERTAINTY.....	5
TEST FACILITY	5
SYSTEM TEST CONFIGURATION	6
DESCRIPTION OF TEST CONFIGURATION	6
EUT EXERCISE SOFTWARE	6
EQUIPMENT MODIFICATIONS	6
LOCAL SUPPORT EQUIPMENT LIST AND DETAILS	6
EXTERNAL I/O CABLE.....	6
BLOCK DIAGRAM OF TEST SETUP	7
SUMMARY OF TEST RESULTS	8
TEST EQUIPMENT LIST	9
FCC§15.247 (I), §1.1307 (B) (1) & §2.1093 – RF EXPOSURE	11
APPLICABLE STANDARD	11
RSS-102 – RF EXPOSURE	12
APPLICABLE STANDARD	12
§ 15.317, § 15.203 & RSS-GEN §6.8 ANTENNA REQUIREMENT	13
APPLICABLE STANDARD	13
ANTENNA CONNECTOR CONSTRUCTION	13
§ 15.315, § 15.207 & RSS-213 §5.4 CONDUCTED EMISSIONS	14
APPLICABLE STANDARD	14
EUT SETUP	14
EMI TEST RECEIVER SETUP.....	15
TEST PROCEDURE	15
FACTOR & MARGIN CALCULATION	15
TEST DATA	15
§ 15.323 (A) & RSS-213 §5.5 EMISSION BANDWIDTH	22
APPLICABLE STANDARD	22
TEST PROCEDURE	22
TEST DATA	23
§ 15.319 (C) & RSS-213 §5.6 PEAK TRANSMIT POWER	25
APPLICABLE STANDARD	25
TEST PROCEDURE	25
TEST DATA	26
§ 15.319 (D) & RSS-213 §5.7 POWER SPECTRAL DENSITY	30
APPLICABLE STANDARD	30
TEST PROCEDURE	30
TEST DATA	30
§ 15.323 (D) & RSS-213 §5.8 EMISSION INSIDE AND OUTSIDE THE SUB-BAND	35

APPLICABLE STANDARD	35
TEST PROCEDURE	36
FACTOR & MARGIN CALCULATION	36
TEST DATA	37
§ 15.323 (F) & RSS-213 §5.3 FREQUENCY STABILITY.....	60
APPLICABLE STANDARD	60
TEST PROCEDURE	60
TEST DATA	61
§ 15.323 (C)(E)§ 15.319 (F) & RSS-213 §5.1&§5.2 SPECIFIC REQUIREMENTS FOR UPCS DEVICE	62
APPLICABLE STANDARD	62
TEST PROCEDURE	62
TEST DATA	62
1) AUTOMATIC DISCONTINUATION OF TRANSMISSION.....	63
2) MONITORING TIME	63
3) LOWER MONITORING THRESHOLD.....	63
4) MAXIMUM TRANSMIT PERIOD	64
5) SYSTEM ACKNOWLEDGEMENT	64
6) LEAST INTERFERED CHANNEL (LIC)	65
7) RANDOM WAITING	67
8) MONITORING BANDWIDTH AND REACTION TIME	68
9) MONITORING ANTENNA.....	69
10) MONITORING THRESHOLD RELAXATION	69
11) DUPLEX CONNECTIONS.....	69
12) ALTERNATIVE MONITORING INTERVAL.....	71
13) FAIR ACCESS	72
14) FRAME REPETITION STABILITY FRAME PERIOD AND JITTER	72

GENERAL INFORMATION

Product Description for Equipment under Test (EUT)

HVIN	W57R
FVIN	118.85.254.3
Frequency Range	1921.536-1928.448 MHz
Maximum conducted peak output power	20.18dBm
Modulation Technique	GFSK
Antenna Specification*	0 dBi (It is provided by the applicant)
Voltage Range	DC 3.7V from battery or DC 5.0V from adapter
Sample serial number	SZNS220328-10962E-RF-S1 for Conducted and Radiated Emissions SZNS220328-10962E-RF-S2 for RF Conducted Test (Assigned by ATC)
Sample/EUT Status	Good condition
Adapter 1 information	Model: YLPS050600B1-US Input: AC 100-120V, 50-60Hz, 0.2A Output: DC 5.0V, 600 mA
Adapter 2 information	Model: YLPS050600C1-US Input: AC 100-120V, 50-60Hz, 0.2A Output: DC 5.0V, 0.6A
Adapter 3 information	Model: YLPS050600E1-US Input: AC 100-120V, 50-60Hz, 0.2A Output: DC 5.0V, 0.6A

Objective

The tests were performed in order to determine the compliance of the EUT with FCC Part 15-Subpart D, section 15.207, 15.315, 15.317, 15.319 and 15.323 rules. The EMI measurements were performed according to the measurement procedure described in ANSI C63.17 – 2013 and RSS-213 Issue 3, 2GHz License-Exempt Personal Communications Service Devices (PCS) OF THE Canadian Department of Industry rules and RSS-GEN ISSUE 5, FEBRUARY 2021 AMENDMENT 2 of the Innovation, Science and Economic Development Canada rules.

Test Methodology

All measurements contained in this report were conducted with ANSI C63.17 - 2013, American National Standard Methods of Measurement of the Electromagnetic and Operational Compatibility of Unlicensed Personal Communications Services (UPCS) Devices.

All emissions measurement was performed at Shenzhen Accurate Technology Co., Ltd. The radiated testing was performed at an antenna-to-EUT distance of 3 meters.

Each test item follows test standards and with no deviation.

Measurement Uncertainty

Parameter		Uncertainty
Occupied Channel Bandwidth		5%
RF output power, conducted		0.73dB
Unwanted Emission, conducted		1.6dB
Emissions, Radiated	30MHz - 1GHz	4.28dB
	1GHz- 18GHz	4.98dB
	18GHz- 26.5GHz	5.06dB
Temperature		1°C
Humidity		6%
Supply voltages		0.4%

Note: The extended uncertainty given in this report is obtained by combining the standard uncertainty times the coverage factor K with the 95% confidence interval. Otherwise required by the applicant or Product Regulations, Decision Rule in this report did not consider the uncertainty.

Test Facility

The test site used by Shenzhen Accurate Technology Co., Ltd. to collect test data is located on the 1/F., Building A, Changyuan New Material Port, Science & Industry Park, Nanshan District, Shenzhen, Guangdong, P.R. China.

The test site has been approved by the FCC under the KDB 974614 D01 and is listed in the FCC Public Access Link (PAL) database, FCC Registration No.: 708358, the FCC Designation No.: CN1189. Accredited by American Association for Laboratory Accreditation (A2LA) The Certificate Number is 429 7.01.

Listed by Innovation, Science and Economic Development Canada (ISED), the Registration Number is 5077A.

SYSTEM TEST CONFIGURATION

Description of Test Configuration

The system was configured to testing mode which is provided by the manufacturer.

EUT Exercise Software

“DECT-ExRfTool”* exercise software was used and the power level is D7*. The software and power level was provided by the applicant.

Equipment Modifications

No modification was made to the EUT tested.

Local Support Equipment List and Details

Manufacturer	Description	Model	Serial Number
Rohde & Schwarz	Digital Radio Communication Tester	CMD60	830861/029

External I/O Cable

Cable Description	Length (m)	From Port	To
Un-shielded un-detachable DC cable	2.0	Adapter	Charger

Block Diagram of Test Setup

Conducted Emission:

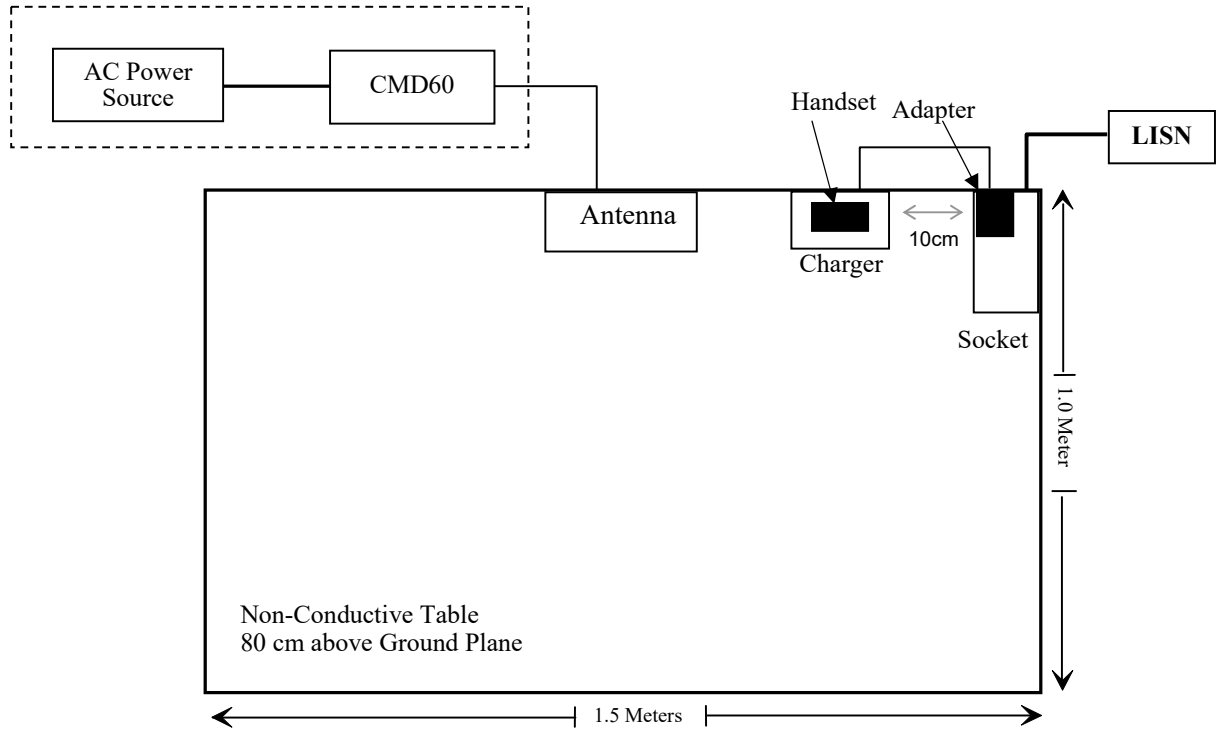

Radiated Emission:

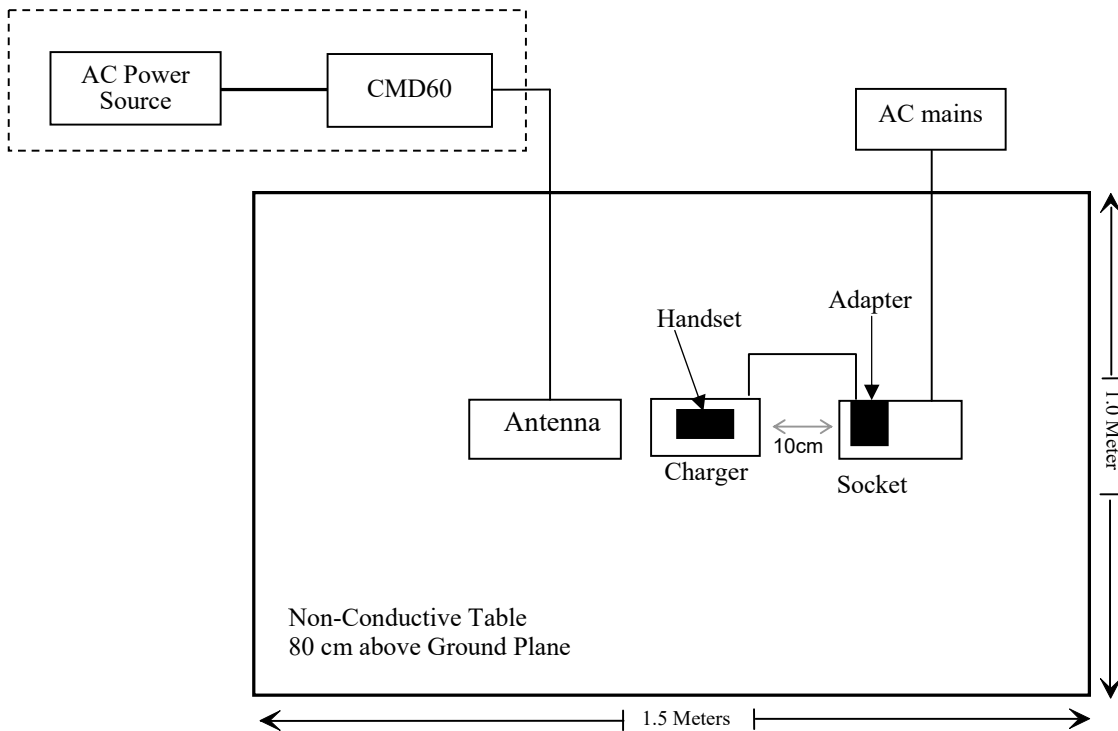

SUMMARY OF TEST RESULTS

FCC Rules	ISED Rules	Description of Test	Result
& 2.1093	RSS-102	RF Exposure	Compliant
§ 15.317, § 15.203	RSS-Gen §6.8	Antenna Requirement	Compliant
§ 15.315, § 15.207	RSS-213 §5.4	Conducted Emission	Compliant
§ 15.323 (a)	RSS-213 §5.5	Emission Bandwidth	Compliant
§ 15.319 (c)	RSS-213 §5.6	Peak Transmit Power	Compliant
§ 15.319 (d)	RSS-213 §5.7	Power Spectral Density	Compliant
§ 15.323 (d)	RSS-213 §5.8	Emission Inside and Outside the sub-band	Compliant
/	RSS-213 §5.8	Radiated Emission	Compliant
§ 15.323 (f)	RSS-213 §5.3	Frequency Stability	Compliant
§ 15.323 (c)(e) § 15.319 (f)	RSS-213 §5.1&§5.2	Specific Requirements for UPCS	Compliant

Note: EUT have two antennas, pre-scan the output power, antenna 1 is higher, so antenna 1 is chosen for the full test.

TEST EQUIPMENT LIST

Manufacturer	Description	Model	Serial Number	Calibration Date	Calibration Due Date
Conducted Emissions Test					
Rohde& Schwarz	EMI Test Receiver	ESCI	100784	2021/12/13	2022/12/12
Rohde & Schwarz	L.I.S.N.	ENV216	101314	2021/12/13	2022/12/12
Anritsu Corp	50 Coaxial Switch	MP59B	6100237248	2021/12/13	2022/12/12
Unknown	RF Coaxial Cable	N-2m	No.2	2021/12/25	2022/12/24
Conducted Emission Test Software: e3 19821G (V9)					
Radiated Emission Test					
Rohde& Schwarz	Test Receiver	ESR	102725	2021/12/13	2022/12/12
Rohde&Schwarz	Spectrum Analyzer	FSV40	101949	2021/12/13	2022/12/12
SONOMA INSTRUMENT	Amplifier	310 N	186131	2021/11/09	2022/11/08
A.H. Systems, inc.	Preamplifier	PAM-0118P	135	2021/11/09	2022/11/08
Quinstar	Amplifier	QLW-18405536-J0	15964001002	2021/11/11	2022/11/10
Schwarzbeck	Bilog Antenna	VULB9163	9163-323	2021/07/06	2024/07/05
Schwarzbeck	Horn Antenna	BBHA9120D	9120D-1067	2020/01/05	2023/01/04
Schwarzbeck	HORN ANTENNA	BBHA9170	9170-359	2020/01/05	2023/01/04
Radiated Emission Test Software: e3 19821G (V9)					
Unknown	RF Coaxial Cable	No.10	N050	2021/12/14	2022/12/13
Unknown	RF Coaxial Cable	No.11	N1000	2021/12/14	2022/12/13
Unknown	RF Coaxial Cable	No.12	N040	2021/12/14	2022/12/13
Unknown	RF Coaxial Cable	No.13	N300	2021/12/14	2022/12/13
Unknown	RF Coaxial Cable	No.14	N800	2021/12/14	2022/12/13
Unknown	RF Coaxial Cable	No.15	N600	2021/12/14	2022/12/13
Unknown	RF Coaxial Cable	No.16	N650	2021/12/14	2022/12/13
Wainwright	High Pass Filter	WHKX3.6/18 G-10SS	5	2021/12/14	2022/12/13

Manufacturer	Description	Model	Serial Number	Calibration Date	Calibration Due Date
RF Conducted test					
Rohde & Schwarz	Spectrum Analyzer	FSV-40	101495	2021/12/13	2022/12/12
Rohde & Schwarz	Digital Radio Communication Tester	CMD60	830861/029	2021/07/09	2022/07/08
AGILENT	Vector Signal Generator	N5182A	MY50143401	2021/12/13	2022/12/12
Fluke	Multi Meter	45	7664009	2021/12/14	2022/12/13
Manson	DC Power Source	KPS-6604	ATCS-205	NCR	NCR
Rohde & Schwarz	Vector Signal Generator	SMBV100A	260434	2021/12/13	2022/12/12
Mini-Circuits	Power Splitter	DC-18000MHz	SF10944151S	2021/12/14	2022/12/13
Gongwen	Temp. & Humid. Chamber	HSD-500	109	2021/10/14	2022/10/13
Unknown	RF Coaxial Cable	No.31	RF-01	Each time	
Unknown	RF Cable	Unknown	Unknown	Each time	

* **Statement of Traceability:** Shenzhen Accurate Technology Co., Ltd. attests that all calibrations have been performed in accordance to requirements that traceable to National Primary Standards and International System of Units (SI).

FCC§15.247 (i), §1.1307 (b) (1) & §2.1093 – RF EXPOSURE

Applicable Standard

According to FCC §2.1093 and §1.1307(b) (1), systems operating under the provisions of this section shall be operated in a manner that ensure that the public is not exposed to radio frequency energy level in excess of the Commission's guideline.

Measurement Result

Please refer to SAR test report: SZNS220328-10962E-SAA.

RSS-102 – RF EXPOSURE

Applicable Standard

According to RSS-102, systems operating under the provisions of this section shall be operated in a manner that ensures that the public is not exposed to radio frequency energy level in excess of the Commission's guideline.

Result: Pass.

Please refer to SAR Report Number: SZNS220328-10962E-SAB.

§ 15.317, § 15.203 & RSS-Gen §6.8 ANTENNA REQUIREMENT

Applicable Standard

According to FCC § 15.203, an intentional radiator shall be designed to ensure that no antenna other than that furnished by the responsible party shall be used with the device. The use of a permanently attached antenna or of an antenna that uses a unique coupling to the intentional radiator shall be considered sufficient to comply with the provisions of this Section. The manufacturer may design the unit so that a broken antenna can be replaced by the user, but the use of a standard antenna jack or electrical connector is prohibited.

The applicant for equipment certification shall provide a list of all antenna types that may be used with the transmitter, where applicable (i.e. for transmitters with detachable antenna), indicating the maximum permissible antenna gain (in dBi) and the required impedance for each antenna. The test report shall demonstrate the compliance of the transmitter with the limit for maximum equivalent isotropically radiated power (e.i.r.p.) specified in the applicable RSS, when the transmitter is equipped with any antenna type, selected from this list.

For expediting the testing, measurements may be performed using only the antenna with highest gain of each combination of transmitter and antenna type, with the transmitter output power set at the maximum level. However, the transmitter shall comply with the applicable requirements under all operational conditions and when in combination with any type of antenna from the list provided in the test report (and in the notice to be included in the user manual, provided below).

When measurements at the antenna port are used to determine the RF output power, the effective gain of the device's antenna shall be stated, based on a measurement or on data from the antenna's manufacturer.

The test report shall state the RF power, output power setting and spurious emission measurements with each antenna type that is used with the transmitter being tested.

For licence-exempt equipment with detachable antennas, the user manual shall also contain the following notice in a conspicuous location:

This radio transmitter [enter the device's ISED certification number] has been approved by Innovation, Science and Economic Development Canada to operate with the antenna types listed below, with the maximum permissible gain indicated. Antenna types not included in this list that have a gain greater than the maximum gain indicated for any type listed are strictly prohibited for use with this device. Immediately following the above notice, the manufacturer shall provide a list of all antenna types which can be used with the transmitter, indicating the maximum permissible antenna gain (in dBi) and the required impedance for each antenna type.

Antenna Connector Construction

The EUT has two integral antenna arrangements, all antennas were permanently attached and both the gain is 0dBi, fulfill the requirement of this section. Please refer to the EUT photos.

Type	Antenna Gain	Impedance
Metal	0 dBi	50 Ω

§ 15.315, § 15.207 & RSS-213 §5.4 CONDUCTED EMISSIONS

Applicable Standard

FCC§15.315, an unlicensed PCS device that is designed to be connected to the public utility (AC) power line must meet the limits specified in §15.207.

A radio apparatus that is designed to be connected to the public utility (AC) power line shall ensure that the radio frequency voltage, which is conducted back onto the AC power line on any frequency or frequencies within the band 150 kHz-30 MHz, shall not exceed the limits in the below table.

Unless the requirements applicable to a given device state otherwise, for any radio apparatus equipped to operate from the public utility AC power supply either directly or indirectly (such as with a battery charger), the radio frequency voltage of emissions conducted back onto the AC power lines in the frequency range of 0.15 MHz to 30 MHz shall not exceed the limits shown in below table. The more stringent limit applies at the frequency range boundaries.

Table - AC Power Lines Conducted Emission Limits		
Frequency range (MHz)	Conducted limit (dB μ V)	
	Quasi-Peak	Average**
0.15 – 0.5	66 to 56*	56 to 46*
0.5 – 5	56	46
5 – 30	60	50

Note: *Decreases with the logarithm of the frequency
 ** A linear average detector is required

EUT Setup

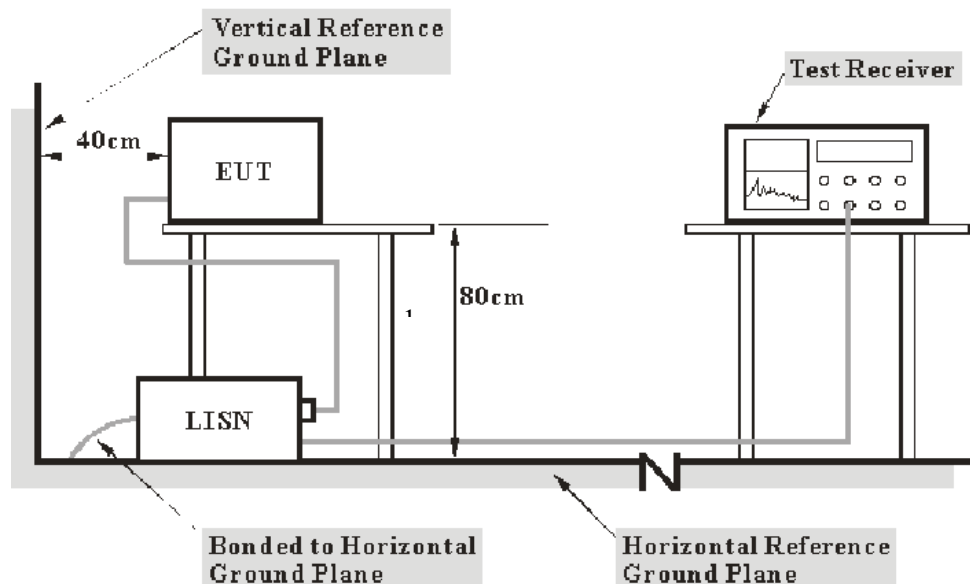

- Note: 1. Support units were connected to second LISN.
 2. Both of LISNs (AMN) 80 cm from EUT and at the least 80 cm from other units and other metal planes support units.

The setup of EUT is according with per ANSI C63.10-2013 measurement procedure. The specification used was with the FCC 15.315, FCC 15.207 and RSS-Gen limits.

The external I/O cables were draped along the test table and formed a bundle 30 to 40 cm long in the middle.

The spacing between the peripherals was 10 cm.

EMI Test Receiver Setup

The EMI test receiver was set to investigate the spectrum from 150 kHz to 30 MHz.

During the conducted emission test, the EMI test receiver was set with the following configurations:

Frequency Range	IF B/W
150 kHz – 30 MHz	9 kHz

Test Procedure

During the conducted emission test, adapter was connected to the outlet of the LISN.

Maximizing procedure was performed on the six (6) highest emissions of the EUT.

All final data was recorded in the Quasi-peak and average detection mode.

Factor & Margin Calculation

The Factor is calculated by adding the LISN Insertion Loss, Cable Loss. The basic equation is as follows:

$$\text{Factor} = \text{LISN Insertion Loss} + \text{Cable Loss}$$

The “**Over Limit**” column of the following data tables indicates the degree of compliance with the applicable limit. For example, a over limit of -7 dB means the emission is 7 dB below the limit. The equation for margin calculation is as follows:

$$\begin{aligned} \text{Over Limit} &= \text{Level} - \text{Limit} \\ \text{Level} &= \text{Read level} + \text{Factor} \end{aligned}$$

Test Data

Environmental Conditions

Temperature:	24 °C
Relative Humidity:	48 %
ATM Pressure:	101.0 kPa

The testing was performed by Caro Hu on 2022-04-21.

EUT operation mode: Transmitting(worst case is Low channel)

Adapter 1(Model: YLPS050600B1-US)

AC 120V/60 Hz, Line

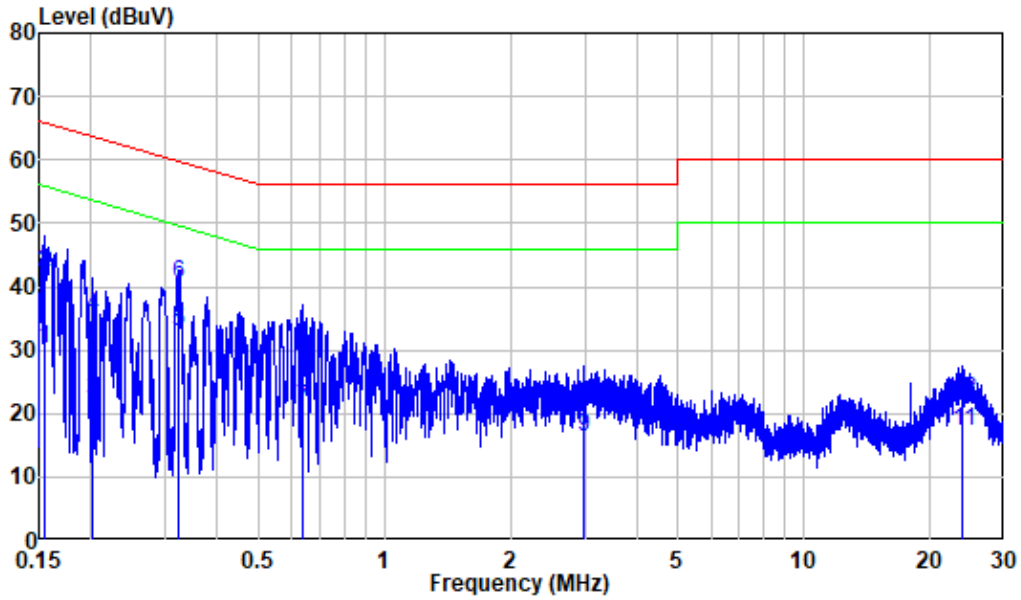

	Freq	Factor	Read Level	Limit Level	Limit Line	Over Limit	Remark
	MHz	dB	dBuV	dBuV	dBuV	dB	
1	0.154	9.80	20.54	30.34	55.76	-25.42	Average
2	0.154	9.80	32.50	42.30	65.76	-23.46	QP
3	0.202	9.80	12.11	21.91	53.55	-31.64	Average
4	0.202	9.80	25.66	35.46	63.55	-28.09	QP
5	0.323	9.80	23.03	32.83	49.62	-16.79	Average
6	0.323	9.80	30.60	40.40	59.62	-19.22	QP
7	0.636	9.81	10.90	20.71	46.00	-25.29	Average
8	0.636	9.81	20.70	30.51	56.00	-25.49	QP
9	2.972	9.83	6.44	16.27	46.00	-29.73	Average
10	2.972	9.83	11.48	21.31	56.00	-34.69	QP
11	23.856	10.04	7.21	17.25	50.00	-32.75	Average
12	23.856	10.04	11.85	21.89	60.00	-38.11	QP

AC 120V/60 Hz, Neutral

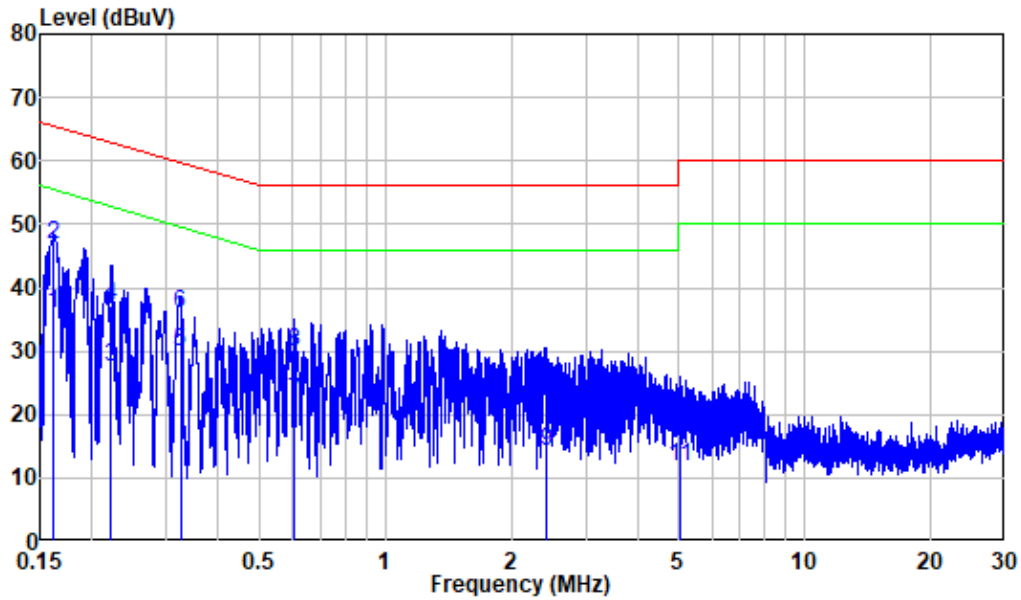

	Freq	Factor	Read Level	Limit Level	Limit Line	Over Limit	Remark
	MHz	dB	dBuV	dBuV	dBuV	dB	
1	0.162	9.80	26.02	35.82	55.37	-19.55	Average
2	0.162	9.80	36.95	46.75	65.37	-18.62	QP
3	0.222	9.80	17.73	27.53	52.73	-25.20	Average
4	0.222	9.80	27.38	37.18	62.73	-25.55	QP
5	0.324	9.80	20.24	30.04	49.59	-19.55	Average
6	0.324	9.80	26.26	36.06	59.59	-23.53	QP
7	0.606	9.81	12.16	21.97	46.00	-24.03	Average
8	0.606	9.81	20.07	29.88	56.00	-26.12	QP
9	2.422	9.82	4.25	14.07	46.00	-31.93	Average
10	2.422	9.82	13.86	23.68	56.00	-32.32	QP
11	5.025	9.89	1.93	11.82	50.00	-38.18	Average
12	5.025	9.89	8.63	18.52	60.00	-41.48	QP

Adapter 2(Model: YLPS050600C1-US)

AC 120V/60 Hz, Line

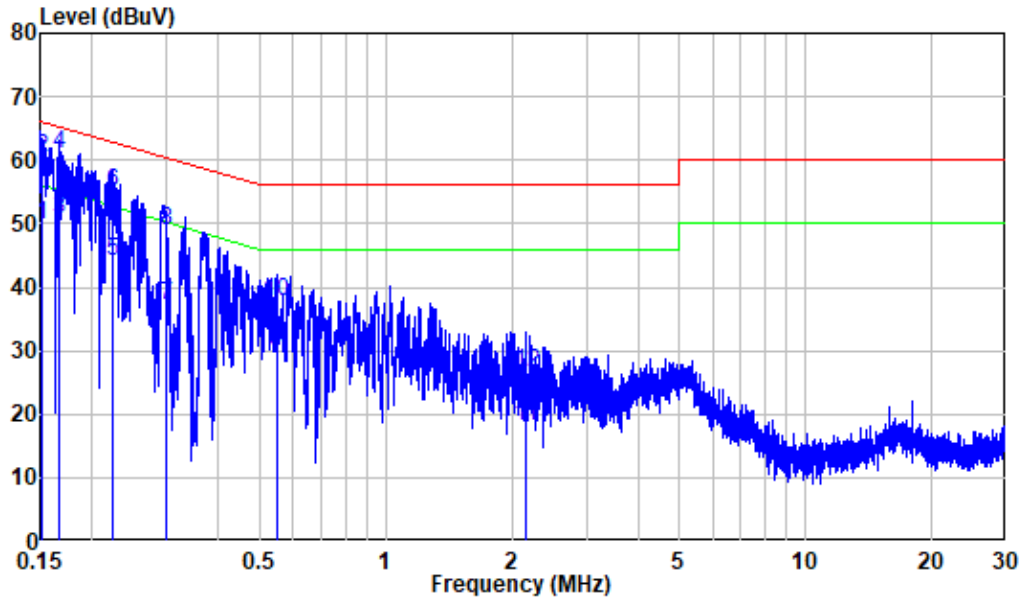

	Freq	Factor	Read Level	Level	Limit Line	Over Limit	Remark
	MHz	dB	dBuV	dBuV	dBuV	dB	
1	0.152	9.80	40.01	49.81	55.87	-6.06	Average
2	0.152	9.80	50.68	60.48	65.87	-5.39	QP
3	0.167	9.80	41.02	50.82	55.12	-4.30	Average
4	0.167	9.80	51.33	61.13	65.12	-3.99	QP
5	0.222	9.80	34.35	44.15	52.73	-8.58	Average
6	0.222	9.80	45.10	54.90	62.73	-7.83	QP
7	0.300	9.80	27.36	37.16	50.24	-13.08	Average
8	0.300	9.80	39.00	48.80	60.24	-11.44	QP
9	0.548	9.81	20.17	29.98	46.00	-16.02	Average
10	0.548	9.81	27.84	37.65	56.00	-18.35	QP
11	2.148	9.82	8.28	18.10	46.00	-27.90	Average
12	2.148	9.82	16.62	26.44	56.00	-29.56	QP

AC 120V/60 Hz, Neutral

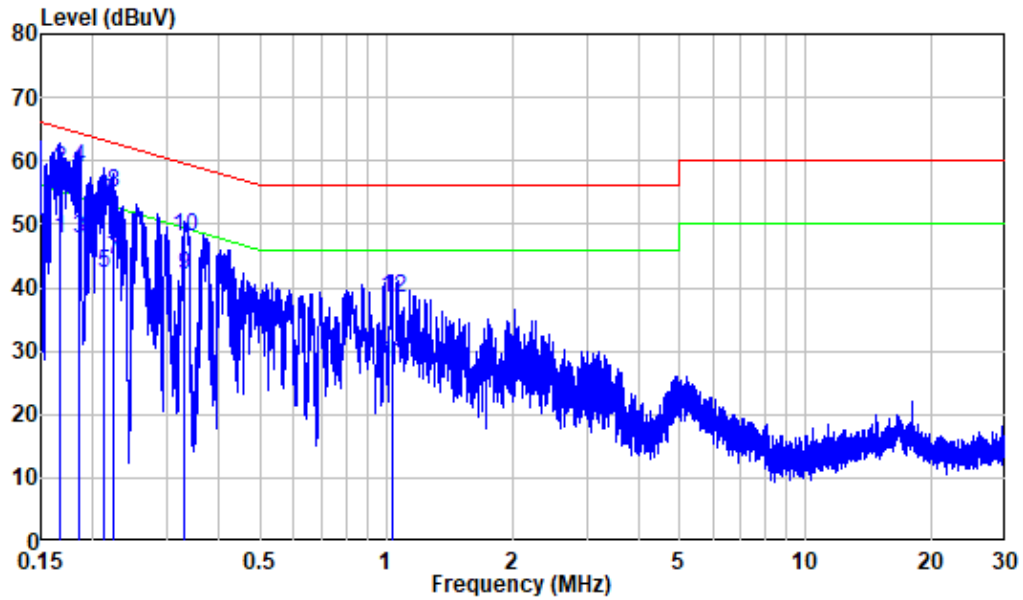

	Freq	Factor	Read Level	Limit Level	Limit Line	Over Limit	Remark
	MHz	dB	dBuV	dBuV	dBuV	dB	
1	0.166	9.80	37.96	47.76	55.15	-7.39	Average
2	0.166	9.80	48.87	58.67	65.15	-6.48	QP
3	0.184	9.80	37.99	47.79	54.28	-6.49	Average
4	0.184	9.80	49.04	58.84	64.28	-5.44	QP
5	0.213	9.80	32.45	42.25	53.11	-10.86	Average
6	0.213	9.80	44.08	53.88	63.11	-9.23	QP
7	0.223	9.80	34.65	44.45	52.70	-8.25	Average
8	0.223	9.80	45.19	54.99	62.70	-7.71	QP
9	0.330	9.80	32.20	42.00	49.44	-7.44	Average
10	0.330	9.80	38.12	47.92	59.44	-11.52	QP
11	1.030	9.81	18.20	28.01	46.00	-17.99	Average
12	1.030	9.81	28.63	38.44	56.00	-17.56	QP

Adapter 3(Model: YLPS050600E1-US)

AC 120V/60 Hz, Line

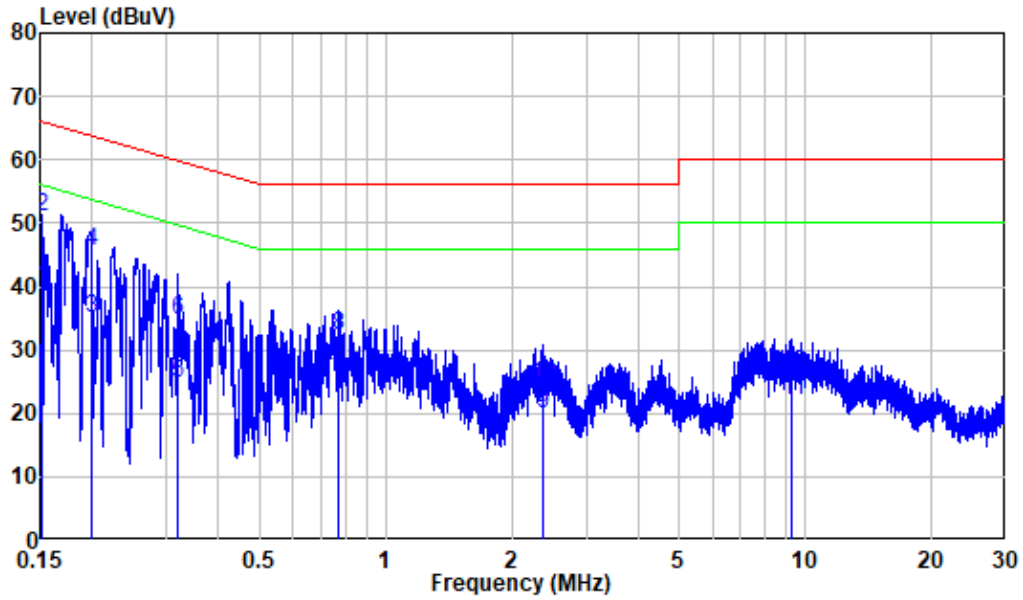

	Freq	Factor	Read Level	Level	Limit	Over Limit	Remark
	MHz	dB	dBuV	dBuV	dBuV	dB	
1	0.151	9.80	29.91	39.71	55.92	-16.21	Average
2	0.151	9.80	41.12	50.92	65.92	-15.00	QP
3	0.200	9.80	25.24	35.04	53.61	-18.57	Average
4	0.200	9.80	35.77	45.57	63.61	-18.04	QP
5	0.320	9.80	15.00	24.80	49.71	-24.91	Average
6	0.320	9.80	24.99	34.79	59.71	-24.92	QP
7	0.774	9.81	15.16	24.97	46.00	-21.03	Average
8	0.774	9.81	22.40	32.21	56.00	-23.79	QP
9	2.373	9.82	10.13	19.95	46.00	-26.05	Average
10	2.373	9.82	14.69	24.51	56.00	-31.49	QP
11	9.296	9.89	12.10	21.99	50.00	-28.01	Average
12	9.296	9.89	16.49	26.38	60.00	-33.62	QP

AC 120V/60 Hz, Neutral

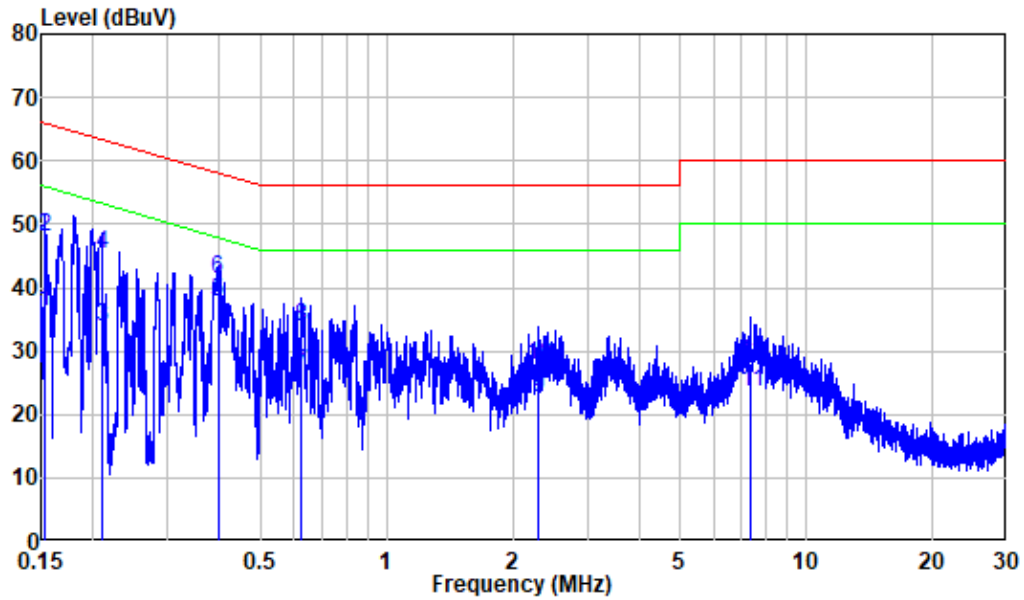

	Freq	Factor	Read Level	Limit Level	Limit Line	Over Limit	Remark
	MHz	dB	dBuV	dBuV	dBuV	dB	
1	0.154	9.80	26.30	36.10	55.81	-19.71	Average
2	0.154	9.80	38.08	47.88	65.81	-17.93	QP
3	0.209	9.80	24.00	33.80	53.23	-19.43	Average
4	0.209	9.80	35.50	45.30	63.23	-17.93	QP
5	0.396	9.80	28.03	37.83	47.94	-10.11	Average
6	0.396	9.80	31.41	41.21	57.94	-16.73	QP
7	0.627	9.81	16.72	26.53	46.00	-19.47	Average
8	0.627	9.81	24.07	33.88	56.00	-22.12	QP
9	2.295	9.82	12.68	22.50	46.00	-23.50	Average
10	2.295	9.82	18.00	27.82	56.00	-28.18	QP
11	7.378	9.97	13.49	23.46	50.00	-26.54	Average
12	7.378	9.97	18.06	28.03	60.00	-31.97	QP

§ 15.323 (a) & RSS-213 §5.5 EMISSION BANDWIDTH

Applicable Standard

Operation shall be contained within the 1920–1930 MHz band. The emission bandwidth shall be less than 2.5 MHz and greater than 50 kHz.

The emission bandwidth is measured in accordance with ANSI C63.17 sub-clause 6.1.3 using the setup below:

Test Setup 1:

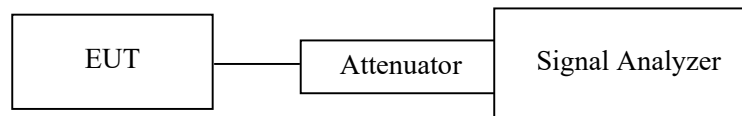

The width, in Hz, of the signal between two points, one below the carrier center frequency and one above the carrier center frequency, that is 26 dB down relative to the maximum level of the modulated carrier. It is based on the use of measurement instrumentation employing a peak detector function with an instrument resolution bandwidth approximately equal to 1% of the emission band-width of the device under measurement. [Extraction from 47 CFR 15, subpart D, 15.303 (C)].

Test Procedure

Using the manufacturer's information on occupied bandwidth set the spectrum analyzer as follows:

Resolution bandwidth	1.0% of the emission bandwidth (as close as possible)
Video bandwidth	>3 times the resolution bandwidth
Number of sweeps	sufficient to stability the trace
Detection mode	peak detection with maximum hold

EBW:

The emission bandwidth (x dB) is defined as the frequency range between two points, one above and one below the carrier frequency, at which the spectral density of the emission is attenuated x dB below the maximum in-band spectral density of the modulated signal. Spectral density (power per unit bandwidth) is to be measured with a detector of resolution bandwidth in the range of 1% to 5% of the anticipated emission bandwidth, and a video bandwidth at least 3x the resolution bandwidth.

OBW:

- The transmitter shall be operated at its maximum carrier power measured under normal test conditions.
- The span of the analyzer shall be set to capture all products of the modulation process, including the emission skirts.
- The resolution bandwidth (RBW) shall be in the range of 1% to 5% of the occupied bandwidth (OBW) and video bandwidth (VBW) shall be approximately 3x RBW.

Test Data

Environmental Conditions

Temperature:	28.9 °C
Relative Humidity:	62 %
ATM Pressure:	101.6 kPa

The testing was performed by Key Pei on 2022-04-12 and 2022-04-14.

Test mode: Transmitting

Channel	Frequency (MHz)	99% Emission Bandwidth (MHz)	26 dB Emission Bandwidth (MHz)	Limit
Low	1921.536	1.233	1.371	50 kHz ~ 2.5 MHz
Middle	1924.992	1.216	1.394	50 kHz ~ 2.5 MHz
High	1928.448	1.216	1.394	50 kHz ~ 2.5 MHz

Test Result: Pass

Please refer to the following plots.

Low Channel

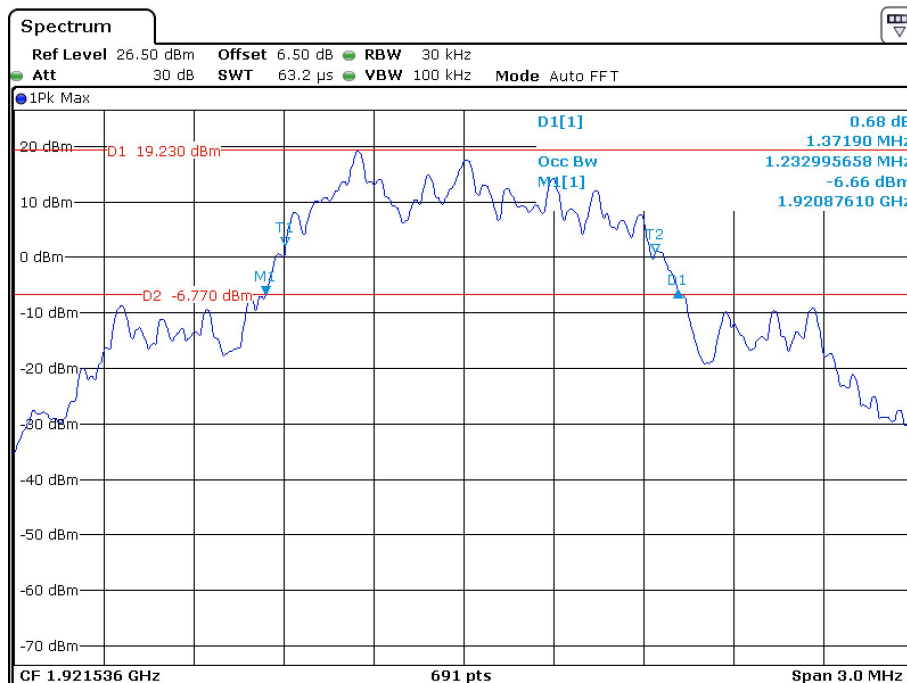

Date: 14.APR.2022 11:10:47

Middle Channel

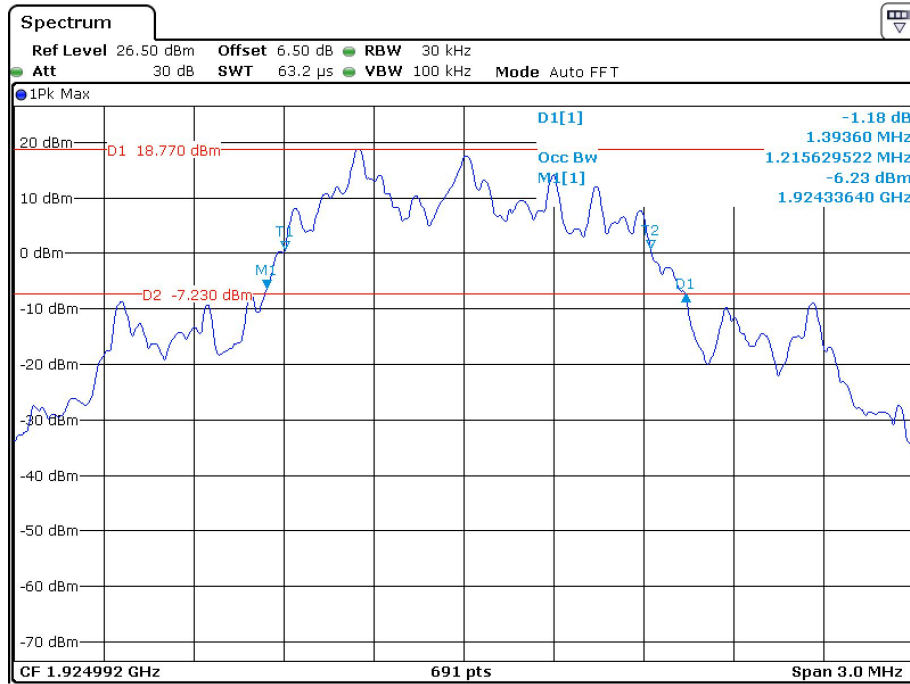

Date: 14.APR.2022 11:11:42

High Channel

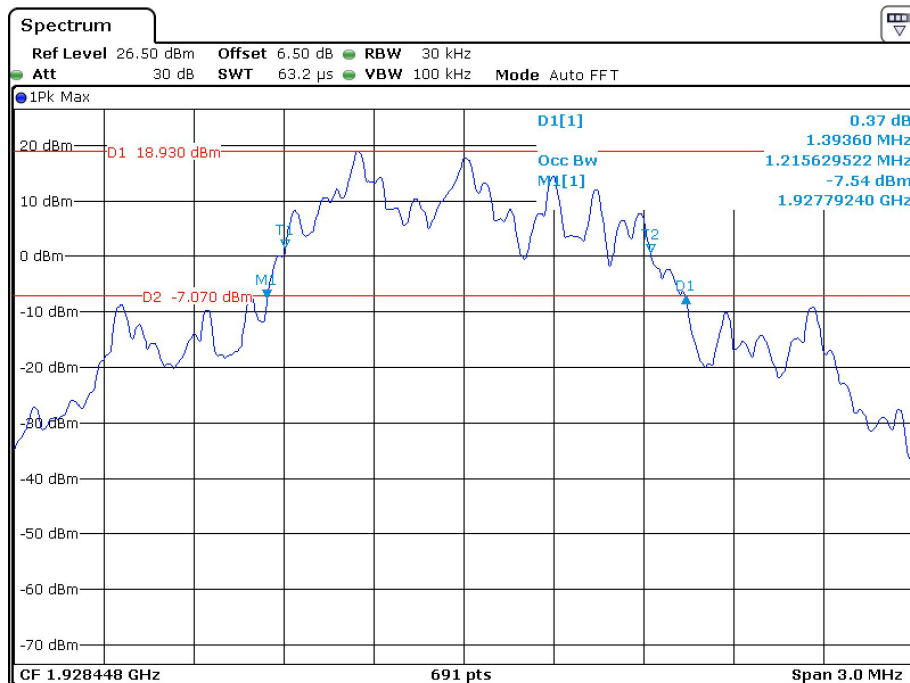

Date: 12.APR.2022 14:45:03

§ 15.319 (c) & RSS-213 §5.6 PEAK TRANSMIT POWER

Applicable Standard

The peak power output as measured over an interval of time equal to the frame rate or transmission burst of the device under all conditions of modulation. Usually this parameter is measured as a conducted emission by direct connection of a calibrated test instrument to the equipment under test. If the device cannot be connected directly, alternative techniques acceptable to the Commission may be used [47 CFR 15, subpart D, 15.303].

The peak transmit power is according to ANSI C63.17-2013 §6.1.2

Per FCC Part 15.319 (c) Peak transmit power shall not exceed 100 microwatts multiplied by the square root of the emission bandwidth in hertz. Peak transmit power must be measured over any interval of continuous transmission using instrumentation calibrated in terms of an rms-equivalent voltage. The measurement results shall be properly adjusted for any instrument limitations, such as detector response times, limited resolution bandwidth capability when compared to the emission bandwidth, sensitivity, etc., so as to obtain a true peak measurement for the emission in question over the full bandwidth of the channel.

Per FCC Part 15.319 (e), the peak transmit power shall be reduced by the amount in decibels that the maximum directional gain of the antenna exceeds 3 dBi.

Calculation of Peak Transmit Power Limit:

$$\text{Peak Transmit Power Limit} = 100\mu\text{W} \times (\text{EBW})^{1/2}$$

EBW is the transmit emission bandwidth in Hz determined in the other test item:

Peak transmit power shall not exceed 100 μW multiplied by the square root of the occupied bandwidth in hertz. The peak transmit power shall be reduced by the amount in decibels that the maximum directional gain of the antenna exceeds 3 dBi.

Test Procedure

Using the manufacturer's information on occupied bandwidth set the spectrum analyzer as follows:

RBW	\geq Emission bandwidth
Video bandwidth	\geq RBW
Span	Zero
Center frequency	Nominal center frequency of channels
Amplitude scale	Log (linear may be used if analyzer has sufficient linear dynamic range and accuracy)
Detection	Peak detection
Trigger	Video
Sweep rate	Sufficiently rapid to permit the transmit pulse to be resolved accurately

Test Data**Environmental Conditions**

Temperature:	28.9 °C
Relative Humidity:	62 %
ATM Pressure:	101.6 kPa

The testing was performed by Key Pei on 2022-04-12.

Test mode: Transmitting:

Test Result: Pass

Please refer to the following table and plots.

Antenna 0

Channel	Frequency (MHz)	Peak Transmit Power (dBm)	Limit (dBm)	ISED Limit (dBm)
Low	1921.536	19.56	20.68	20.45
Middle	1924.992	19.68	20.72	20.42
High	1928.448	19.90	20.72	20.42
FCC: EBW _{Low channel} = 1371000Hz, EBW _{Middle channel} = 1394000 Hz, EBW _{High channel} = 1394000 Hz Peak Transmit Power Limit = $100(\text{EBW})^{1/2} \mu\text{W}$				
ISED: EBW _{Low channel} = 1233000Hz, EBW _{Middle channel} = 1216000Hz, EBW _{High channel} = 1216000 Hz Peak Transmit Power Limit = $100(\text{EBW})^{1/2} \mu\text{W}$				

Antenna 1

Channel	Frequency (MHz)	Peak Transmit Power (dBm)	Limit (dBm)	ISED Limit (dBm)
Low	1921.536	20.00	20.68	20.45
Middle	1924.992	20.13	20.72	20.42
High	1928.448	20.18	20.72	20.42
FCC: EBW _{Low channel} = 1371000Hz, EBW _{Middle channel} = 1394000 Hz, EBW _{High channel} = 1394000 Hz Peak Transmit Power Limit = $100(\text{EBW})^{1/2} \mu\text{W}$				
ISED: EBW _{Low channel} = 1233000Hz, EBW _{Middle channel} = 1216000Hz, EBW _{High channel} = 1216000 Hz Peak Transmit Power Limit = $100(\text{EBW})^{1/2} \mu\text{W}$				

Antenna 0

Low Channel

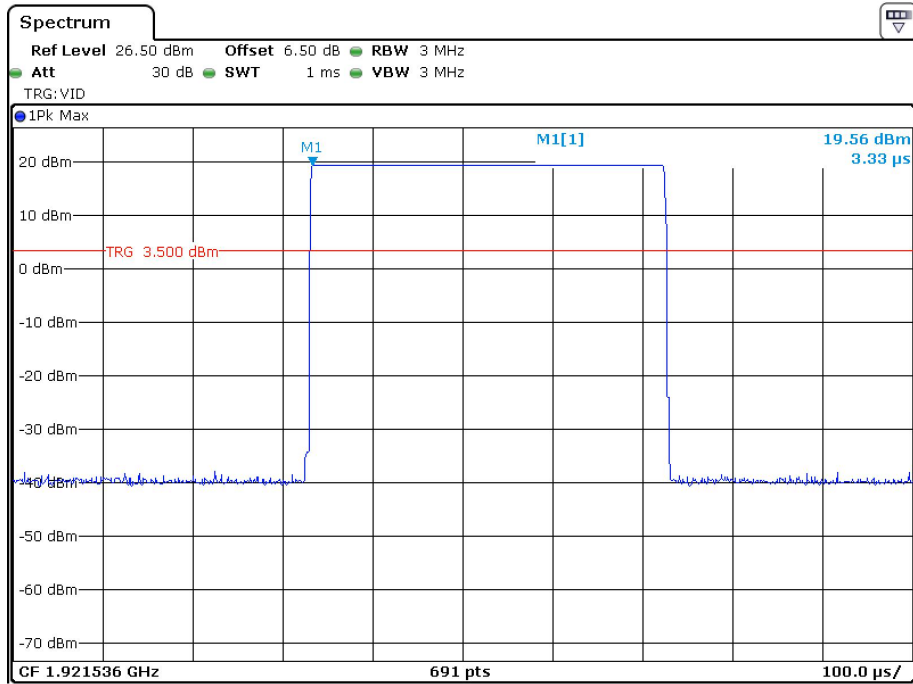

Date: 12.APR.2022 14:34:07

Middle Channel

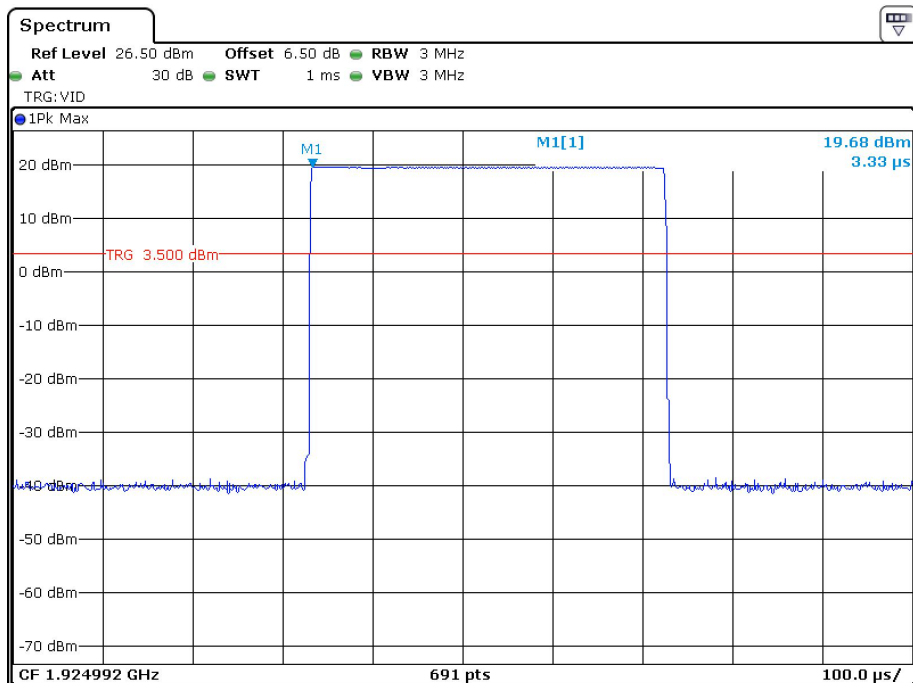

Date: 12.APR.2022 14:34:40

High Channel

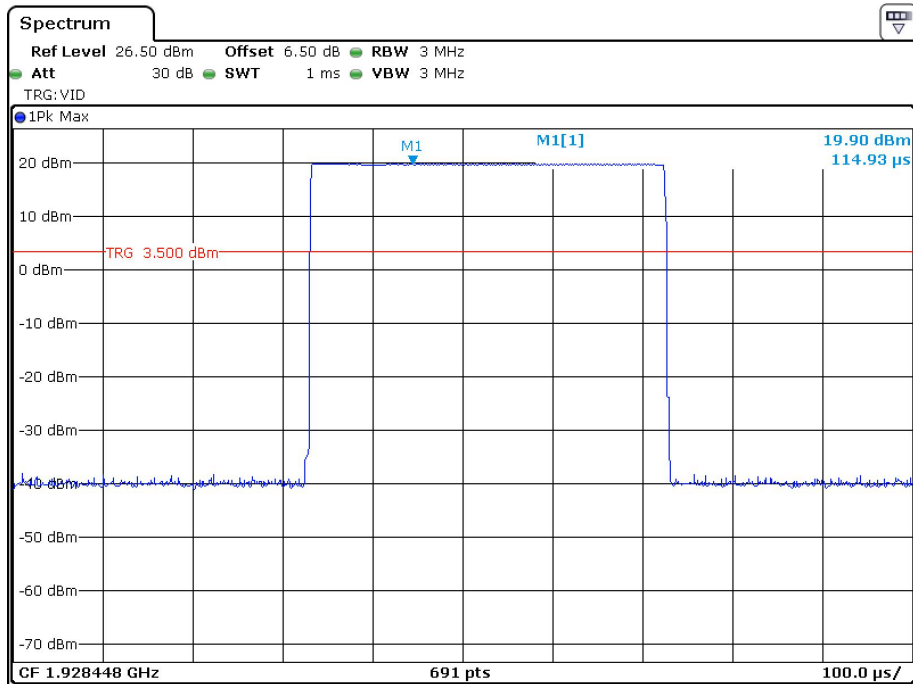

Date: 12.APR.2022 14:35:50

Antenna 1

Low Channel

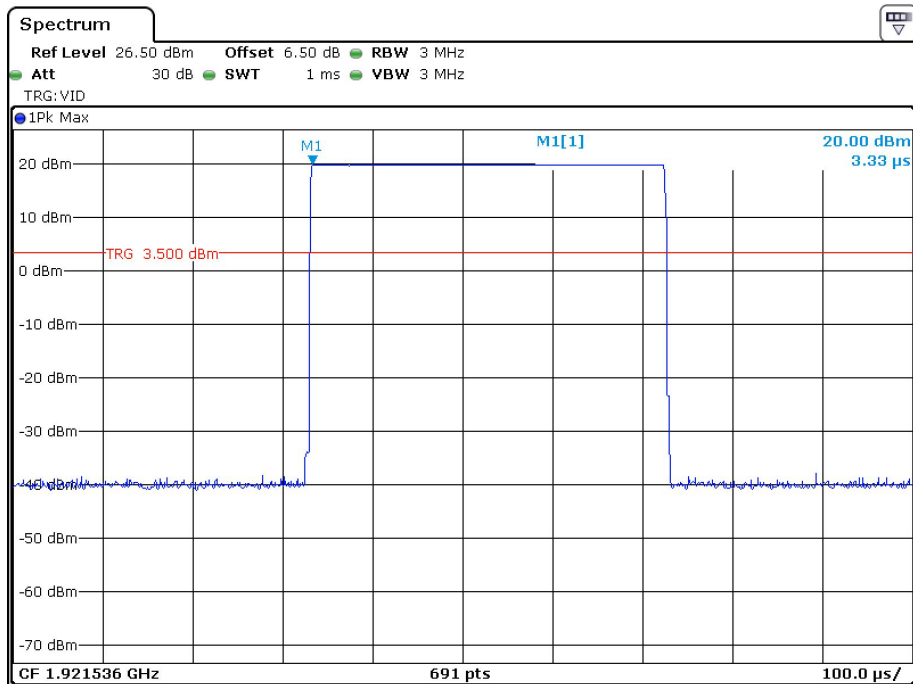

Date: 12.APR.2022 14:30:42

Middle Channel

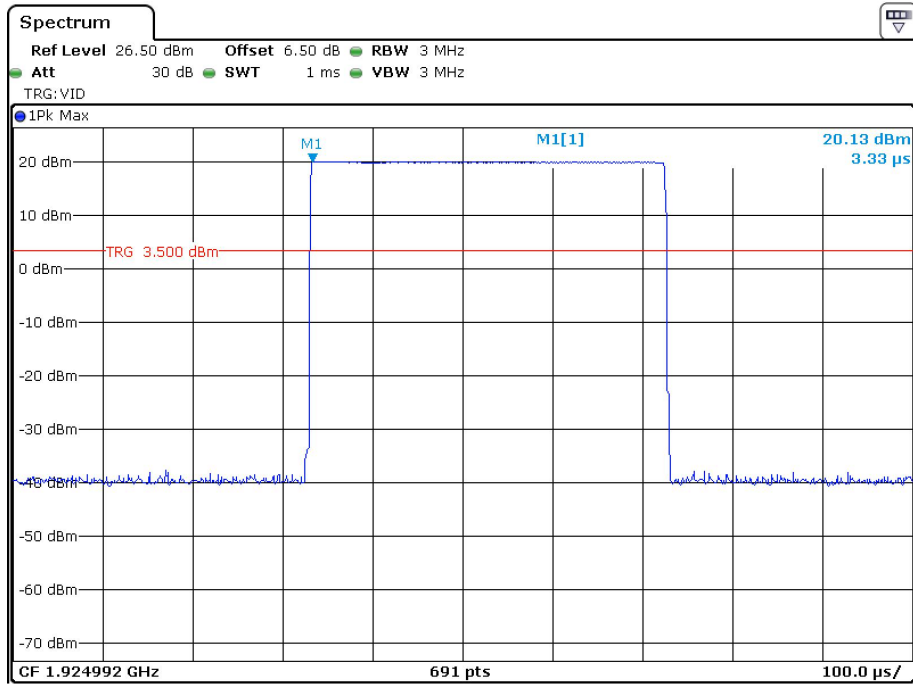

Date: 12.APR.2022 14:28:41

High Channel

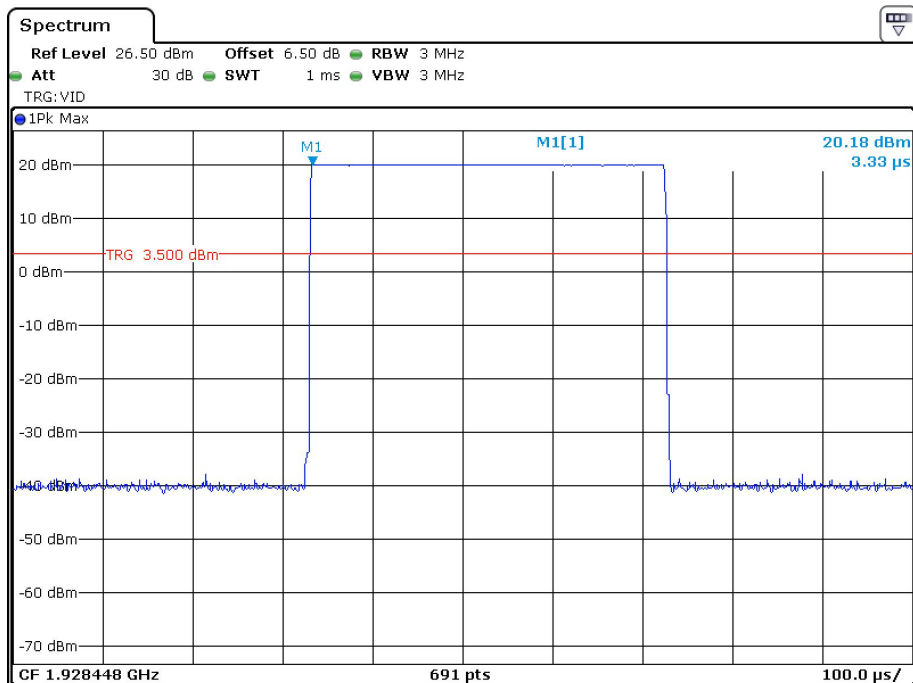

Date: 12.APR.2022 14:29:57

§ 15.319 (d) & RSS-213 §5.7 POWER SPECTRAL DENSITY

Applicable Standard

The average pulse energy in a 3 kHz bandwidth is divided by the pulse duration.

The power spectral density shall not exceed 3mW in any 3 kHz bandwidth as measured with a spectrum analyzer having a resolution bandwidth of 3 kHz.

The power spectral density is measured in accordance with ANSI C63.17-2013 Clause 6.1.5.

The peak-hold power spectral density of transmitters shall not exceed 12 mW per any 3 kHz bandwidth. As an alternative to the peak-hold power spectral density, the time-averaged power spectral density may be measured and it shall not exceed 3 mW per any 3 kHz bandwidth.

Test Procedure

Using the manufacturer's information on occupied bandwidth set the spectrum analyzer as follows:

RBW	3 kHz
Video bandwidth	$\geq 3 \times \text{RBW}$
Span	Zero span at frequency with the maximum level (frequency determined in 6.1.3 if the same type of signal (continuous versus burst) was used in 6.1.3)
Center frequency	Spectral peak as determined in 6.1.3
Sweep time	For burst signals, sufficient to include essentially all of the maximum length burst at the output of a 3 kHz filter (e.g., maximum input burst duration plus 600 μs). For continuous signals, 20 ms.
Amplitude scale	Log power
Detection	Sample detection and averaged for a minimum of 100 sweeps
Trigger	External or internal

Test Data

Environmental Conditions

Temperature:	28.9 °C
Relative Humidity:	62 %
ATM Pressure:	101.6 kPa

The testing was performed by Key Pei on 2022-04-14.

Test Result: Pass

Please refer to following table and plots

Test mode: Transmitting

Channel	Frequency (MHz)	Power Spectral Density		Limit (mW/3kHz)
		(dBm/3kHz)	(mW/3kHz)	
Low	1921.536	-4.18	0.38	3
Middle	1924.992	-0.42	0.91	3
High	1928.448	-0.14	0.97	3

Low Channel

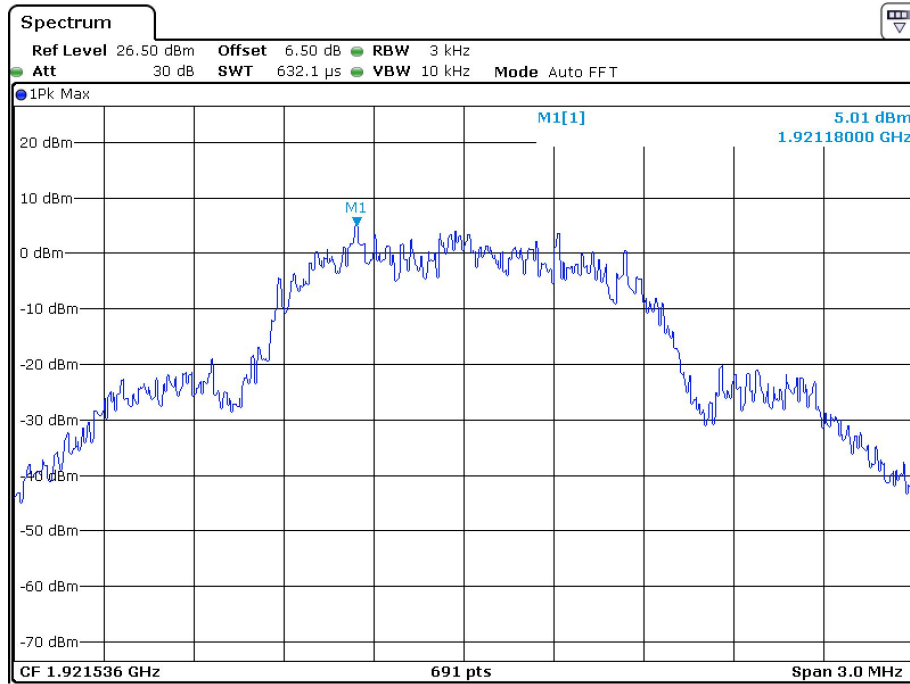

Date: 14.APR.2022 10:58:54

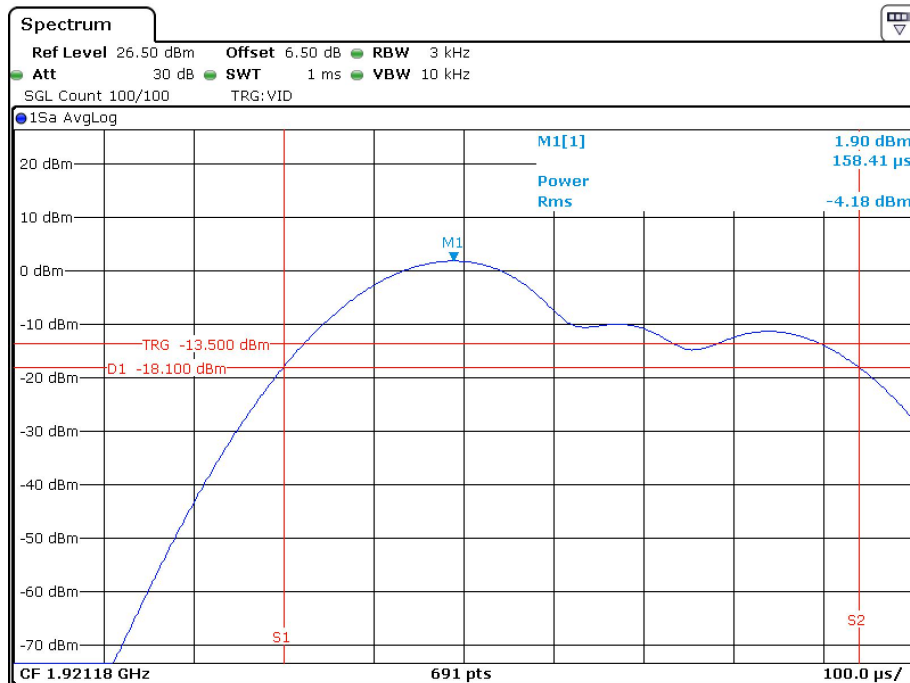

Date: 14.APR.2022 11:00:48

Middle Channel

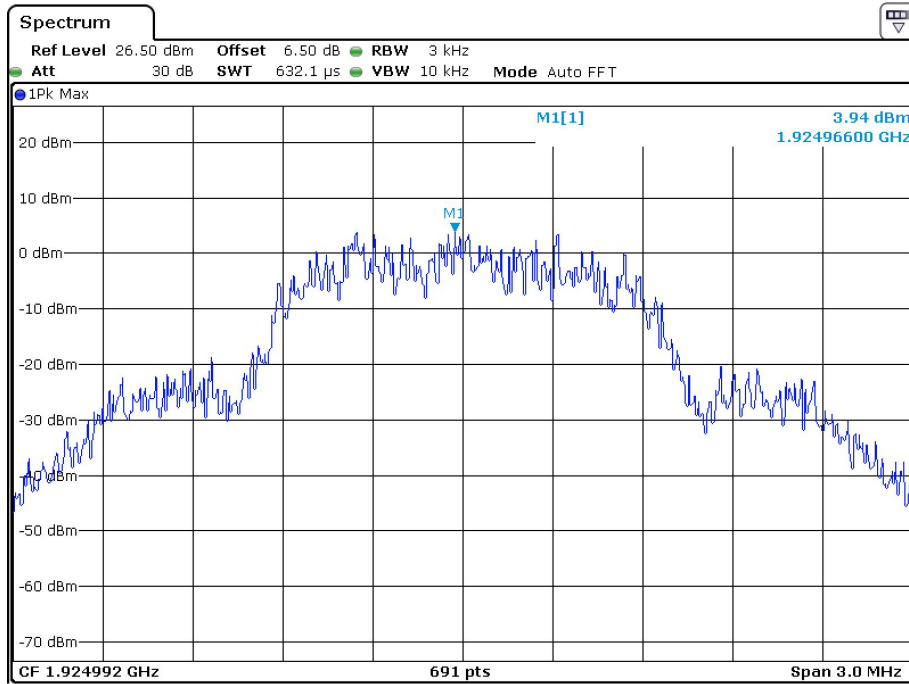

Date: 14.APR.2022 11:01:59

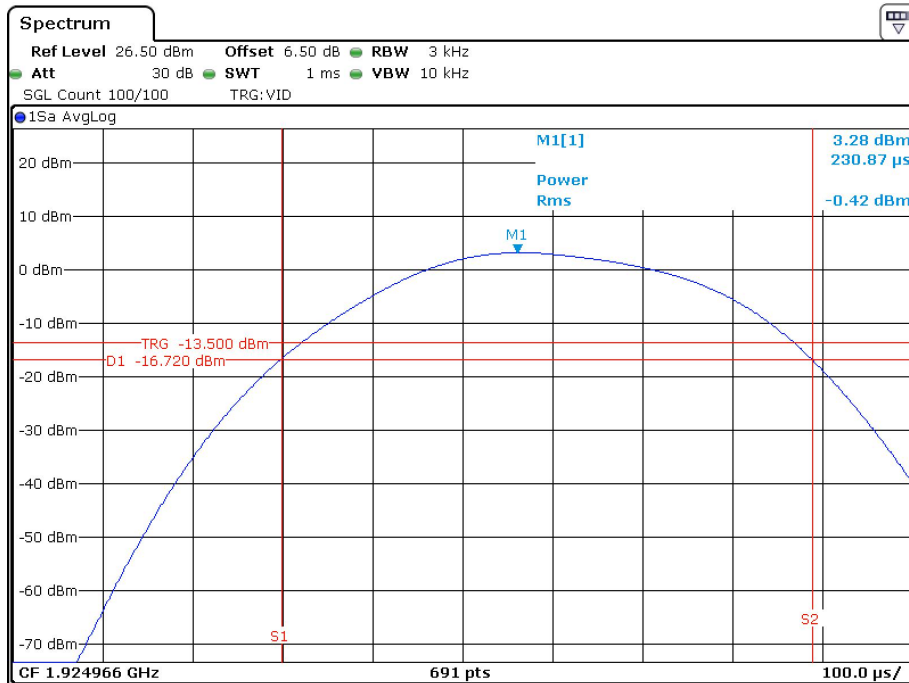

Date: 14.APR.2022 11:05:05

High Channel

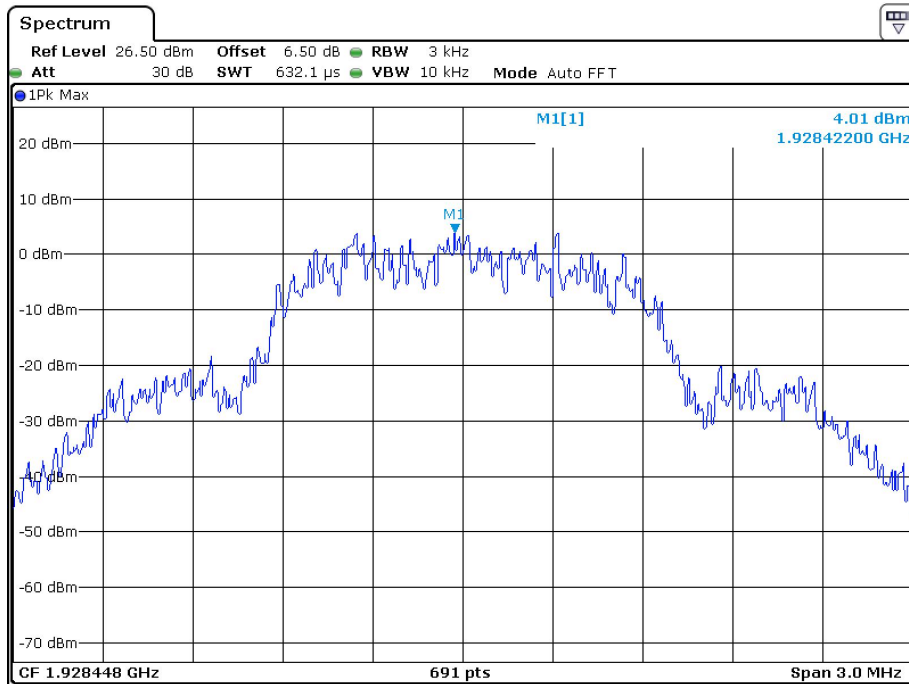

Date: 14.APR.2022 11:05:48

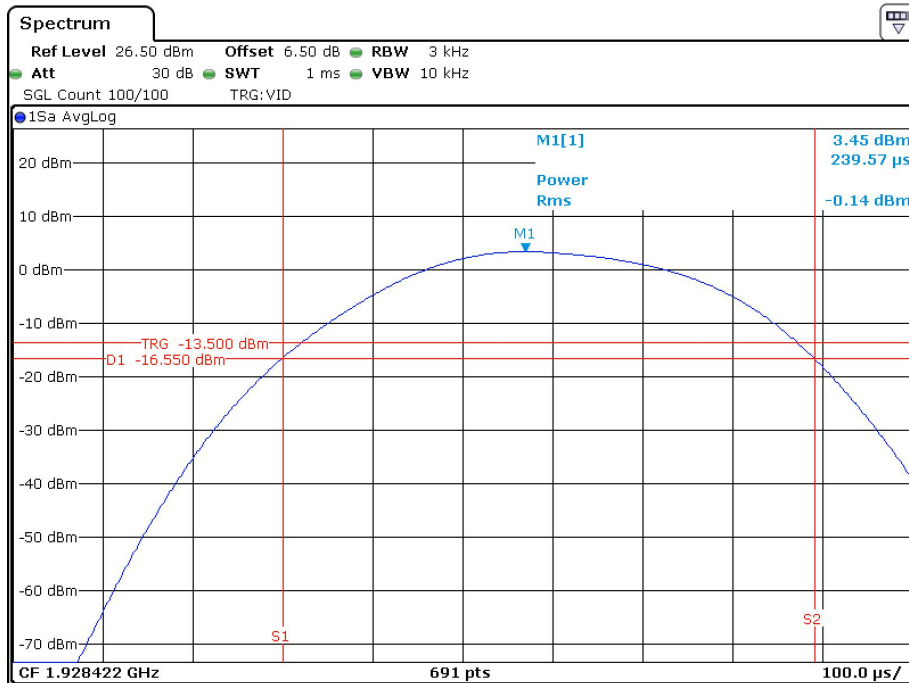

Date: 14.APR.2022 11:07:19

§ 15.323 (d) & RSS-213 §5.8 EMISSION INSIDE AND OUTSIDE THE SUB-BAND

Applicable Standard

Emissions inside the sub-band must comply with the following emission mask:

1. In the bands between 1B and 2B measured from the center of the emission bandwidth the total power emitted by the device shall be at least 30 dB below the transmit power permitted for that device;
2. in the bands between 2B and 3B measured from the center of the emission bandwidth the total power emitted by an intentional radiator shall be at least 50 dB below the transmit power permitted for that radiator;
3. in the bands between 3B and the sub-band edge the total power emitted by an intentional radiator in the measurement bandwidth shall be at least 60 dB below the transmit power permitted for that radiator.

Where B = emission bandwidth

Emission Outside the sub-band shall be attenuated below a reference power of 112 mw (20.5 dBm) as follows:

1. 30 dB between the sub-band and 1.25 MHz above or below the sub-band;
2. 50 dB between 1.25 and 2.5 MHz above or below the sub-band;
3. 60 dB at 2.5 MHz or greater above or below the sub-band.

Emissions outside the 1920-1930 MHz Band

Emissions outside the 1920-1930 MHz band shall be attenuated below a reference power of 112 milliwatts (-9.5 dBW) by at least:

- 30 dB between the band edges and 1.25 MHz above and below the band edges;
- 50 dB between 1.25 MHz and 2.5 MHz above or below the band edges; and
- 60 dB at 2.5 MHz or greater above or below the band edges.

Emissions inside the 1920-1930 MHz Band

Emissions inside the 1920-1930 MHz band shall be attenuated below the transmit power permitted for that device, as follows:

- 30 dB between the frequencies 1B and 2B measured from the centre of the occupied bandwidth;
- 50 dB between the frequencies 2B and 3B measured from the centre of the occupied bandwidth; and
- 60 dB between the frequencies 3B and band edge, where B is the occupied bandwidth in hertz.

Test Procedure

According to ANSI C63.17.2013 Clause 6.1.6.

In-band emission:

Spectrum analyzer settings for measuring in-band emission

RBW	Approximately 1% of the emission bandwidth (B)
Video bandwidth	$3 \times \text{RBW}$
Sweep time	The sweep time shall be sufficiently slow that the swept frequency rate shall not exceed one RBW per three transmit bursts.
Number of sweeps	Sufficient to stabilize the trace
Amplitude scale	Log
Detection	Peak detection and max hold enabled
Span	Approximately equal to $3.5 B$

Out-band emission:

RBW	30kHz
Video bandwidth	100kHz
Center frequency	Nominal center frequency of channels
Amplitude scale	Log (linear may be used if analyzer has sufficient linear dynamic range and accuracy)
Detection	Peak detection

Factor & Margin Calculation

The Factor is calculated by adding the Antenna Factor and Cable Loss, and subtracting the Amplifier Gain. The basic equation is as follows:

$$\text{Factor} = \text{Antenna Factor} + \text{Cable Loss} - \text{Amplifier Gain}$$

The “**Over Limit/Margin**” column of the following data tables indicates the degree of compliance with the applicable limit. For example, an Over Limit/margin of -7dB means the emission is 7dB below the limit. The equation for calculation is as follows:

$$\begin{aligned} \text{Over Limit/Margin} &= \text{Level / Corrected Amplitude} - \text{Limit} \\ \text{Level / Corrected Amplitude} &= \text{Read Level} + \text{Factor} \end{aligned}$$

Test Data**Environmental Conditions**

Temperature:	25~28.9 °C
Relative Humidity:	62~65 %
ATM Pressure:	101.0~101.6 kPa

The testing was performed by Nick Fang on 2022-04-24 for below 1GHz, Nick Fang on 2022-04-27 for above 1GHz and Key Pei on 2022-04-12 for RF conducted.

Test mode: Transmitting

Test Result: Pass

Please refer to following plots

FCC:

Low Channel (Unwanted Emission inside the Sub-band)



Date: 12.APR.2022 14:57:29

Middle Channel (Unwanted Emission inside the Sub-band)

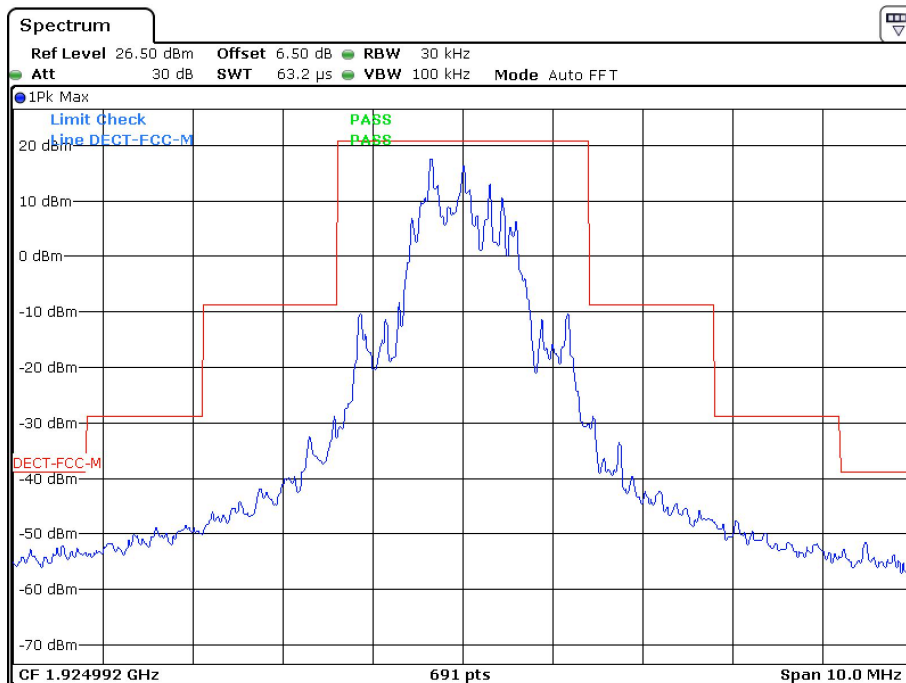

Date: 12.APR.2022 15:12:47

High Channel (Unwanted Emission inside the Sub-band)

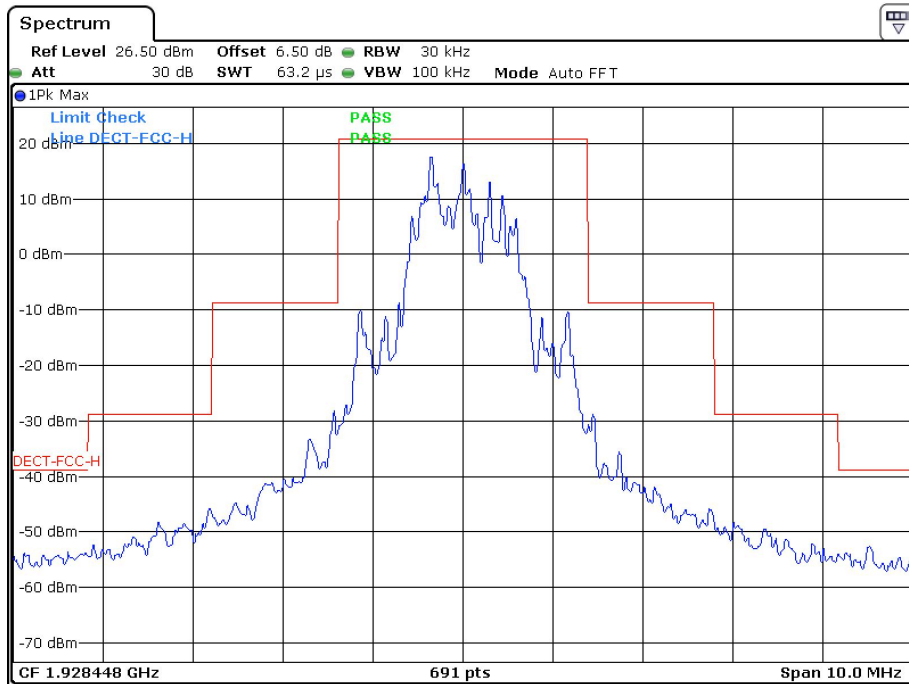

Date: 12.APR.2022 15:10:51

ISEDC:

Low Channel (Unwanted Emission inside the Sub-band)



Date: 12.APR.2022 15:00:25

Middle Channel (Unwanted Emission inside the Sub-band)

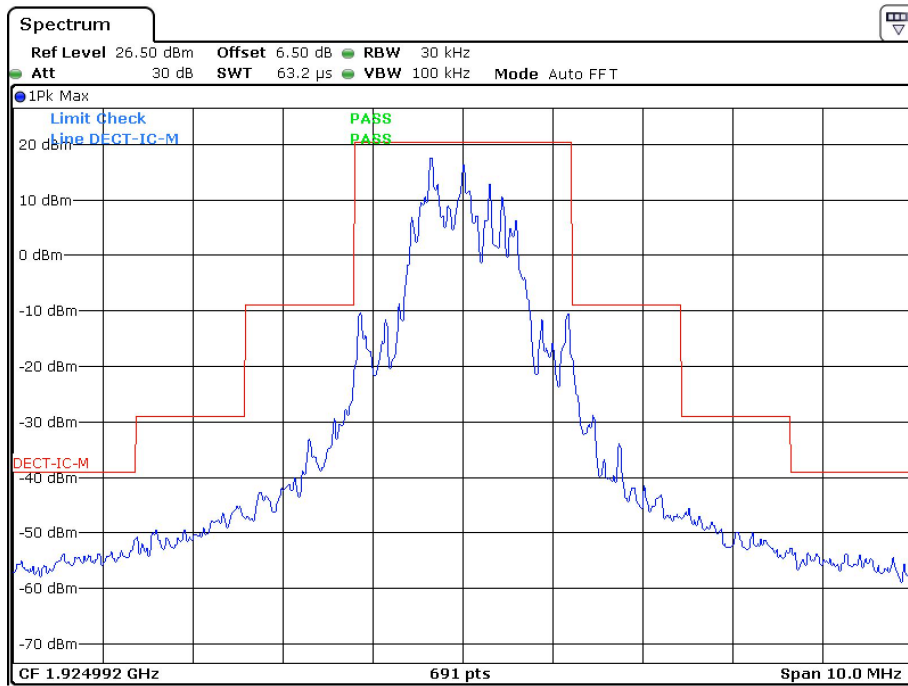

Date: 12.APR.2022 15:14:56

High Channel (Unwanted Emission inside the Sub-band)

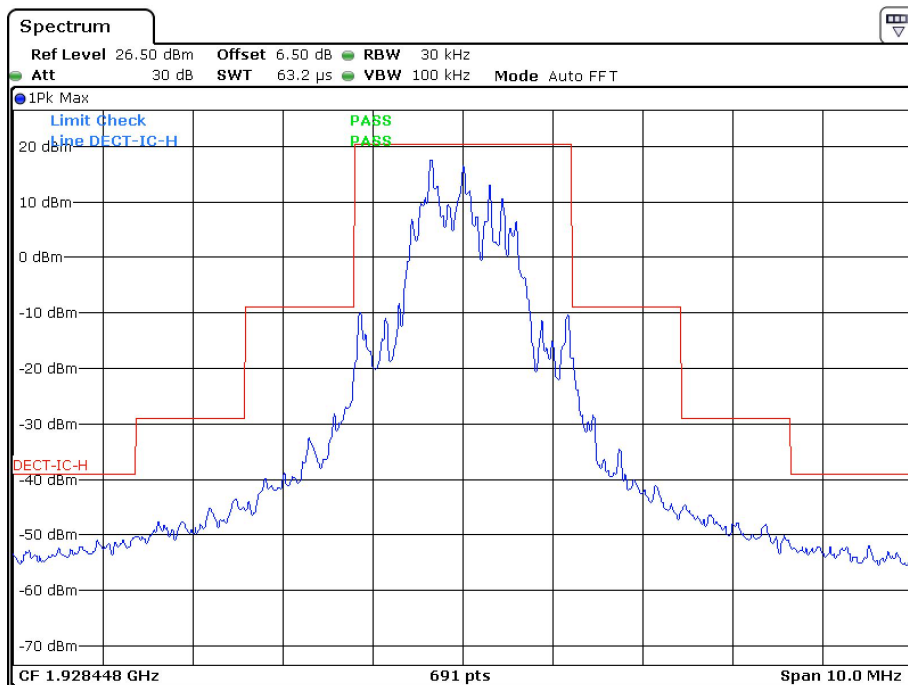

Date: 12.APR.2022 15:08:56