



FCC TEST REPORT

According to

47 CFR, Part 2, Part 15, CISPR PUB. 22

Applicant : YEALINK(XIAMEN) NETWORK TECHNOLOGY CO., LTD
Address : 309, 3th Floor, No.16, Yun Ding North Road, Huli District,
Xiamen City, Fujian, China
Equipment : Media IP Phone
Model No. : SIP-T52S

I HEREBY CERTIFY THAT :

The sample was received on Feb 09, 2017 and the testing was carried out on Feb 23, 2017 at CerpPASS Technology Corp. The test result refers exclusively to the test presented test model / sample. Without written approval of CerpPASS Technology Corp., the test report shall not be reproduced except in full.

Approved by:

Miro Chueh
EMC/RF B.U. Manager



FCC TEST REPORT

Issued by:

CerpPASS Technology (Suzhou) Co.,Ltd

No.66,Tangzhuang Road, Suzhou Industrial Park, Jiangsu 215006, China

Tel:86-512-6917-5888

Fax:86-512-6917-5666

The test record, data evaluation & Equipment. Under Test configurations represented herein are true and accurate accounts of the measurements of the samples EMC characteristics under the conditions specified in this report.

Laboratory Accreditation:

CerpPASS Technology Corporation Test Laboratory

NVLAP LAB Code:	200954-0
TAF LAB Code:	1439

CerpPASS Technology(SuZhou) Co., Ltd.

NVLAP LAB Code:	200814-0
CNAS LAB Code:	L5515



Contents

1. Summary of Test Procedure and Test Result.....	5
1.1. Applicable Standards	5
2. Test Configuration of Equipment under Test	6
2.1. Feature of Equipment under Test.....	6
2.2. Test Manner	6
2.3. Description of Test System.....	7
2.4. Connection Diagram of Test System.....	8
2.5. General Information of Test.....	9
2.6. Measurement Uncertainty	10
3. Test of Conducted Emission.....	11
3.1. Test Limit	11
3.2. Test Procedures	11
3.3. Typical test Setup.....	12
3.4. Measurement Equipment.....	12
3.5. Test Result and Data.....	13
3.6. Test Photographs	17
4. Test of Radiated Emission	18
4.1. Test Limit	18
4.2. Test Procedures	19
4.3. Typical test Setup.....	20
4.4. Measurement Equipment.....	21
4.5. Test Result and Data (30MHz~1GHz).....	22
4.6. Test Result and Data (1GHz ~6GHz).....	28
4.7. Test Photographs (30MHz ~ 1GHz).....	34
4.8. Test Photographs (1GHz ~ 6GHz)	36
5. Photographs of EUT	38



History of this test report

ORIGINAL.

Additional attachment as following record:

Report No	Version	Date	Description
SEFD1702032	Rev 01	Feb 24, 2017	Initial Issue



1. Summary of Test Procedure and Test Result

1.1. Applicable Standards

The measurements shown in this test report were made in accordance with the procedures given in ANSI C63.4 – 2014 and the energy emitted by this equipment was passed Part 2, Part 15, CISPR PUB. 22.



The energy emitted by this equipment was passed both Radiated and Conducted Emissions Class B limits.

Test Item	Normative References	Test Result	Remarks
Conducted Emission	ANSI C63.4-2014 FCC Part 15 Subpart B	PASS	Meets Class B Limit Minimum passing margin(AVG) is -12.38 dB at 4.3580 MHz
Radiated Emission	ANSI C63.4-2014 FCC Part 15 Subpart B	PASS	Meets Class B Limit Minimum passing margin(QP) is -3.45 dB at 259.3700 MHz



2. Test Configuration of Equipment under Test

2.1. Feature of Equipment under Test

Product Name:	Media IP Phone	
Model Name:	SIP-T52S	
Adapter #1:	Model No.:	YLPS052000B-US
	Input:	100-240V~50/60Hz, 350mA
	Output:	5.0V  2.0A
Adapter #2:	Model No.:	YLPS052000C-US
	Input:	100-240V~50/60Hz, 0.5A
	Output:	5.0V  2.0A
FCC ID:	T2C-T52S	

Note: Please refer to user manual.

2.2. Test Manner

- a. During testing, the interface cables and equipment positions were varied according to ANSI C63.4.
- b. Turn on the power of all equipment.
- c. The complete test system included Earphone, POE Switch, Notebook PC, Media IP Phone, Color-screen Expansion Module and EUT for EMI test.
- d. The test mode for CE as follow:
Mode 1: Full System power from YLPS052000B-US Adapter
Mode 2: Full System power from YLPS052000C-US Adapter
The "Test Mode 1,2" were reported as final data.
- e. The test mode for RE as follow:
Mode 1: Full System power from YLPS052000B-US Adapter
Mode 2: Full System power from YLPS052000C-US Adapter
Mode 3: Full System power from POE Switch
The "Test Mode 1,2,3" were reported as final data.
- f. The maximum operating frequency is above 108MHz, the test frequency range is from 30MHz to 18GHz.



2.3. Description of Test System

No.	Device	Manufacturer	Model No.	Description
1	Earphone	Yealink	N/A	N/A
2	POE Switch	D-Link	NES-1008P	Non-Shielded,1.8m
3	Notebook PC	Lenovo	G50	Non-Shielded,1.5m
4	Media IP Phone	Yealink	SIP-T54S	Non-Shielded,1.8m
5	Color-screen Expansion Modulec	Yealink	EXP50	N/A



2.4. Connection Diagram of Test System

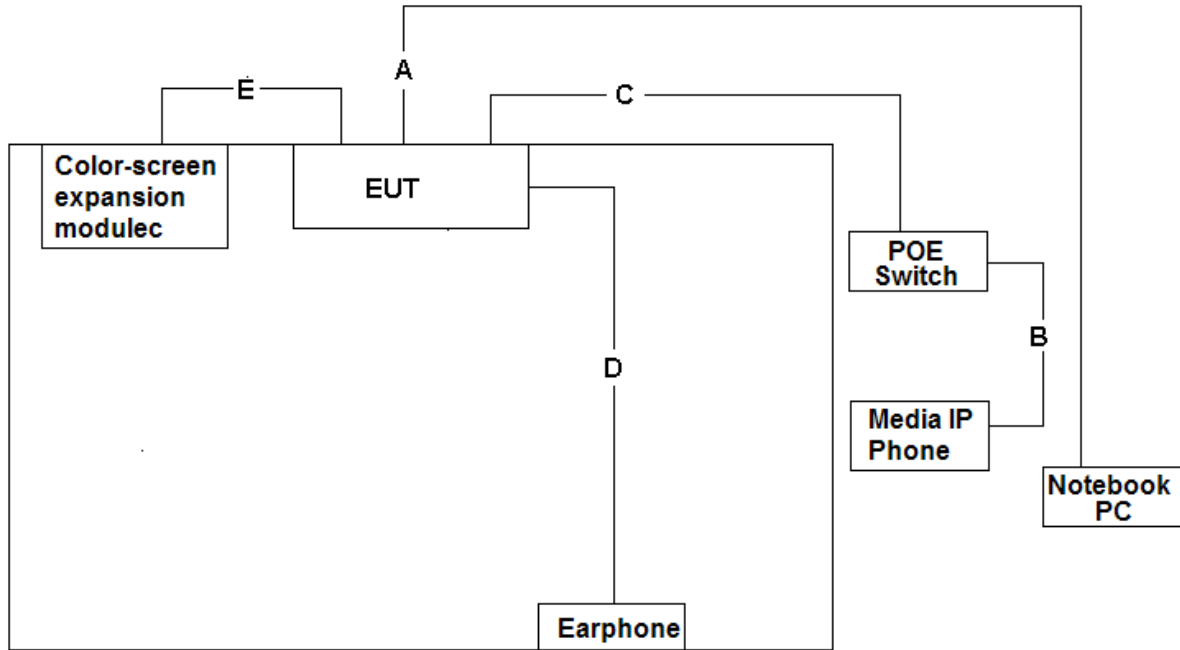

No.	Cable	Quantity	Description
A	LAN Cable	1	Shielded, > 3.0m
B	LAN Cable	1	Shielded, 2.0m
C	LAN Cable	1	Shielded, >3.0m
D	Audio Cable	1	Non-shielded, 2.0m
E	USB Cable	1	Shielded, 0.2m with a core



2.5. General Information of Test

Test Site :	CerpPASS Technology (Suzhou) Co.,Ltd Address: No.66,Tangzhuang Road, Suzhou Industrial Park, Jiangsu 215006, China Tel: +86-512-6917-5888 Fax: +86-512-6917-5666
FCC Registration Number :	331395
IC Registration Number :	7290A-1, 7290A-2
VCCI	T-1945 for Telecommunication Test C-2919 for Conducted emission test R-2670 for Radiated emission test G-227 for radiated disturbance above 1GHz
Frequency Range Investigated :	Conducted Emission Test: from 150 kHz to 30 MHz Radiated Emission Test: from 30 MHz to 6,000 MHz
Test Distance :	The test distance of radiated emission below 1GHz from antenna to EUT is 3 M. The test distance of radiated emission above 1GHz from antenna to EUT is 3 M.



2.6. Measurement Uncertainty

Where relevant, the following measurement uncertainty levels have been estimated for tests performed on the EUT as specified in CISPR 16-4-2:

Test results and Measurement uncertainty without any relationship in the test report.

Measurement	Frequency	Uncertainty
Conducted emissions(LINE)	9KHz-30MHz	+/- 0.7738 dB
Conducted emissions(NEUTRAL)	9KHz-30MHz	+/- 0.7886 dB

Measurement	Polarity	Frequency	Uncertainty
Radiated emissions (below 1GHz)	H	30MHz ~ 200MHz	+/- 3.8909dB
		200MHz ~1000MHz	+/- 3.6555dB
	V	30MHz ~ 200MHz	+/- 3.8948dB
		200MHz ~1000MHz	+/- 3.6538dB
Radiated emissions (above 1GHz)	H	1000MHz ~18000MHz	+/- 3.8948 dB
		18000MHz ~40000MHz	+/-3.8844dB
	V	1000MHz ~18000MHz	+/- 3.8906dB
		18000MHz ~40000MHz	+/- 3.8744dB

This uncertainty represents an expanded uncertainty expressed at approximately the 95% confidence level using a coverage factor of k=2.

Consistent with industry standard (e.g. CISPR 22: 2008, clause 11, Measurement Uncertainty) determining compliance with the limits shall be based on the results of the compliance measurement. Consequently the measured emissions being less than the maximum allowed emission result in this being a compliant test or passing test.



3. Test of Conducted Emission

3.1. Test Limit

Conducted Emissions were measured from 150 kHz to 30 MHz with a bandwidth of 9 KHz on the 120 VAC power and return leads of the EUT according to the methods defined in ANSI C63.4-2014 Section 3.1. The EUT was placed on a nonmetallic stand in a shielded room 0.8 meters above the ground plane as shown in section 2.2. The interface cables and equipment positioning were varied within limits of reasonable applications to determine the position produced maximum conducted emissions.

Conducted Emission Limits:

Frequency (MHz)	Quasi Peak (dB μ V)	Average (dB μ V)
0.15 – 0.5	66-56*	56-46*
0.5 – 5.0	56	46
5.0 – 30.0	60	50

3.2. Test Procedures

- a. The EUT was placed 0.4 meter from the conducting wall of the shielding room was kept at least 80 centimeters from any other grounded conducting surface.
- b. Connect EUT to the power mains through a line impedance stabilization network (LISN).
- c. All the support units are connecting to the other LISN.
- d. The LISN provides 50 ohm coupling impedance for the measuring instrument.
- e. The FCC states that a 50 ohm, 50 micro-Henry LISN should be used.
- f. Both sides of AC line were checked for maximum conducted interference.
- g. The frequency range from 150 kHz to 30 MHz was searched.
- h. Set the test-receiver system to Peak Detect Function and Specified Bandwidth with Maximum Hold Mode.



3.3. Typical test Setup

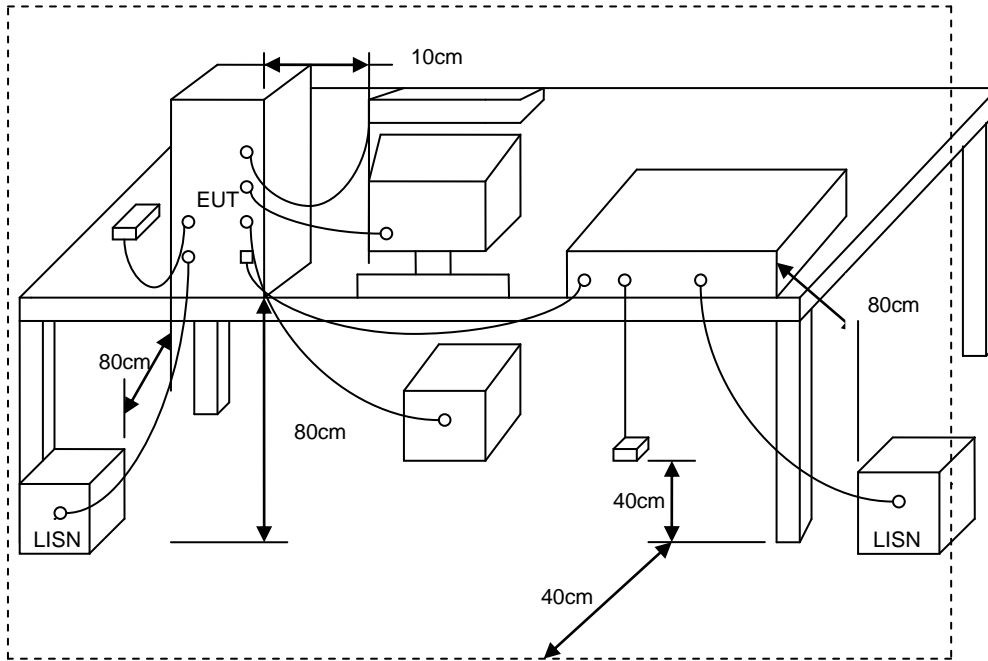

3.4. Measurement Equipment

Instrument/Ancillary	Manufacturer	Model No.	Serial No.	Calibration Date	Valid Date.
Test Receiver	R&S	ESCI	100565	2016.07.07	2017.07.06
AMN	R&S	ESH2-Z5	100182	2016.08.31	2017.08.30
Two-Line V-Network	R&S	ENV216	100325	/	/
ISN	FCC	FCC-TLISN-T2-02	20379	2016.03.26	2017.03.25
ISN	FCC	FCC-TLISN-T4-02	20380	2016.06.24	2017.06.24
ISN	FCC	FCC-TLISN-T8-02	20381	2016.03.26	2017.03.25
ISN	TESEQ	ISN ST08	30175	2016.03.26	2017.03.25
Current Probe	R&S	EZ-17	100303	2016.03.26	2017.03.25
Passive Voltage Probe	R&S	ESH2-Z3	100026	2016.03.26	2017.03.25
Pulse Limiter	R&S	ESH3-Z2	100529	2016.03.26	2017.03.25
Temperature/ Humidity Meter	Zhicheng	ZC1-11	CEP-TH-004	2016.03.29	2017.03.28
EZ-EMC	Fala	Ver CT3A1	N/A	N/A	N/A



3.5. Test Result and Data

Test Mode :	Mode 1: Full System power from YLPS052000B-US Adapter		
AC Power :	AC 120V/60Hz	Phase :	LINE
Equipment :	Media IP Phone	Model No :	SIP-T52S
Temperature :	21°C	Humidity :	54%
Pressure(mbar) :	1002	Date :	2017/02/23

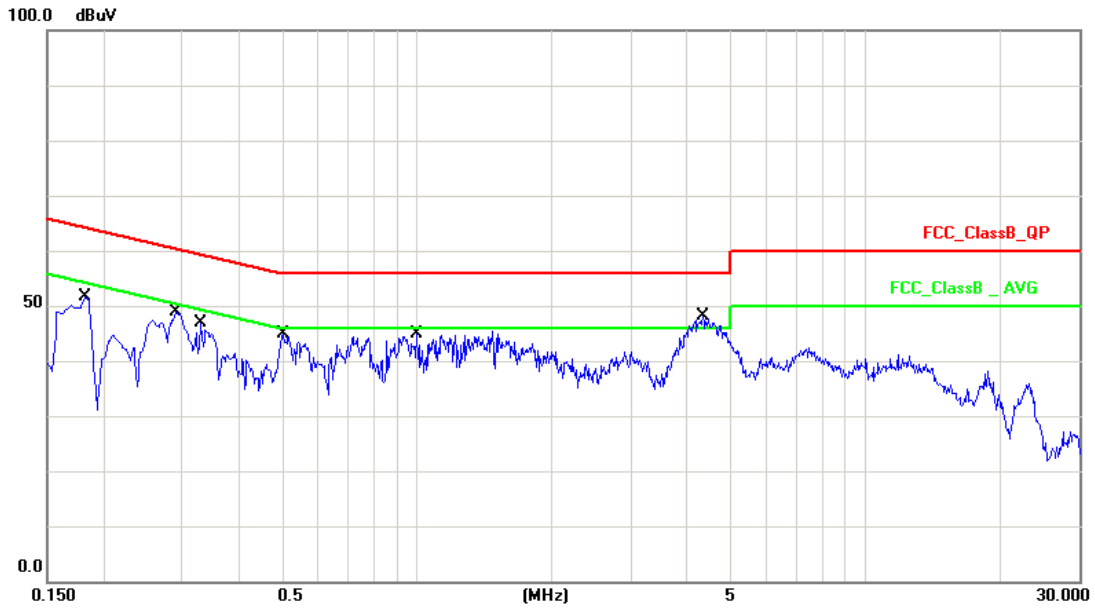

No.	Frequency (MHz)	Factor (dB)	Reading (dBuV)	Level (dBuV)	Limit (dBuV)	Margin (dB)	Detector
1	0.1819	10.12	34.93	45.05	64.39	-19.34	QP
2	0.1819	10.12	17.84	27.96	54.39	-26.43	AVG
3	0.2900	10.14	35.07	45.21	60.52	-15.31	QP
4	0.2900	10.14	26.07	36.21	50.52	-14.31	AVG
5	0.3300	10.14	29.23	39.37	59.45	-20.08	QP
6	0.3300	10.14	18.98	29.12	49.45	-20.33	AVG
7	0.5060	10.16	30.22	40.38	56.00	-15.62	QP
8	0.5060	10.16	22.45	32.61	46.00	-13.39	AVG
9	1.0020	10.16	27.39	37.55	56.00	-18.45	QP
10	1.0020	10.16	19.19	29.35	46.00	-16.65	AVG
11	4.3580	10.22	31.42	41.64	56.00	-14.36	QP
12	4.3580	10.22	23.40	33.62	46.00	-12.38	AVG

Note: Measurement Level = Reading Level + Correct Factor



Test Mode :	Mode 1: Full System power from YLPS052000B-US Adapter		
AC Power :	AC 120V/60Hz	Phase :	NEUTRAL
Equipment :	Media IP Phone	Model No :	SIP-T52S
Temperature :	21°C	Humidity :	54%
Pressure(mbar) :	1002	Date :	2017/02/23

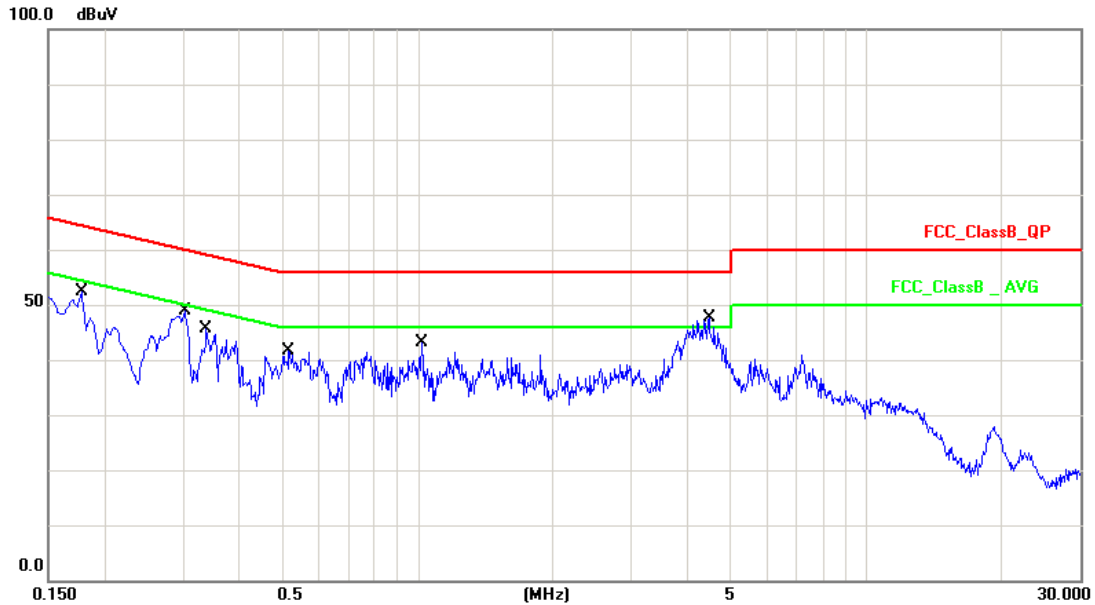

No.	Frequency (MHz)	Factor (dB)	Reading (dBuV)	Level (dBuV)	Limit (dBuV)	Margin (dB)	Detector
1	0.1780	10.13	33.50	43.63	64.57	-20.94	QP
2	0.1780	10.13	19.76	29.89	54.57	-24.68	AVG
3	0.3020	10.14	32.91	43.05	60.19	-17.14	QP
4	0.3020	10.14	26.58	36.72	50.19	-13.47	AVG
5	0.3379	10.14	26.81	36.95	59.25	-22.30	QP
6	0.3379	10.14	19.43	29.57	49.25	-19.68	AVG
7	0.5180	10.15	26.83	36.98	56.00	-19.02	QP
8	0.5180	10.15	20.69	30.84	46.00	-15.16	AVG
9	1.0220	10.18	24.84	35.02	56.00	-20.98	QP
10	1.0220	10.18	18.10	28.28	46.00	-17.72	AVG
11	4.4740	10.24	29.24	39.48	56.00	-16.52	QP
12	4.4740	10.24	23.28	33.52	46.00	-12.48	AVG

Note: Measurement Level = Reading Level + Correct Factor



Test Mode :	Mode 2: Full System power from YLPS052000C-US Adapter		
AC Power :	AC 120V/60Hz	Phase :	LINE
Equipment :	Media IP Phone	Model No :	SIP-T52S
Temperature :	21°C	Humidity :	54%
Pressure(mbar) :	1002	Date :	2017/02/23

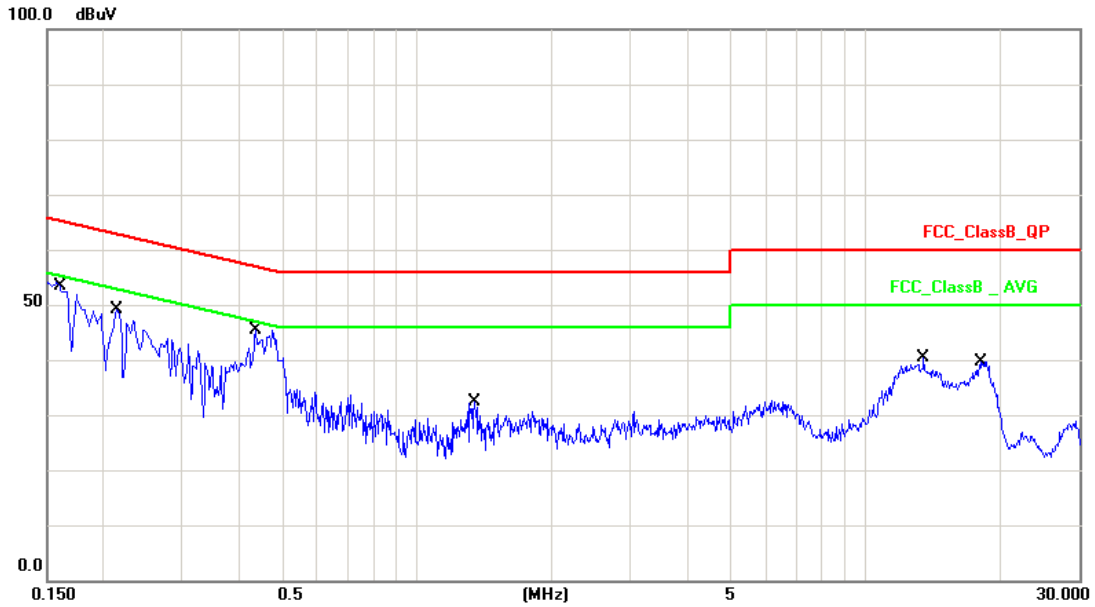

No.	Frequency (MHz)	Factor (dB)	Reading (dBuV)	Level (dBuV)	Limit (dBuV)	Margin (dB)	Detector
1	0.1620	10.13	38.04	48.17	65.36	-17.19	QP
2	0.1620	10.13	18.78	28.91	55.36	-26.45	AVG
3	0.2140	10.12	33.05	43.17	63.04	-19.87	QP
4	0.2140	10.12	16.12	26.24	53.04	-26.80	AVG
5	0.4380	10.15	29.09	39.24	57.10	-17.86	QP
6	0.4380	10.15	17.16	27.31	47.10	-19.79	AVG
7	1.3460	10.16	15.40	25.56	56.00	-30.44	QP
8	1.3460	10.16	5.60	15.76	46.00	-30.24	AVG
9	13.4980	10.44	21.59	32.03	60.00	-27.97	QP
10	13.4980	10.44	14.61	25.05	50.00	-24.95	AVG
11	18.1420	10.41	22.79	33.20	60.00	-26.80	QP
12	18.1420	10.41	14.60	25.01	50.00	-24.99	AVG

Note: Measurement Level = Reading Level + Correct Factor



Test Mode :	Mode 2: Full System power from YLPS052000C-US Adapter		
AC Power :	AC 120V/60Hz	Phase :	NEUTRAL
Equipment :	Media IP Phone	Model No :	SIP-T52S
Temperature :	21°C	Humidity :	54%
Pressure(mbar) :	1002	Date :	2017/02/23

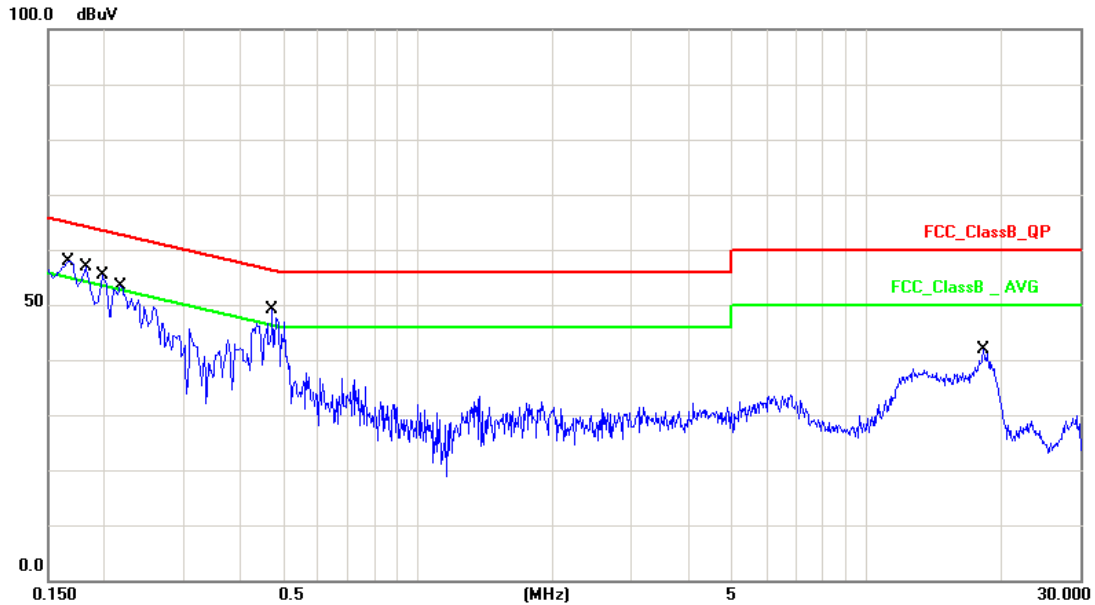

No.	Frequency (MHz)	Factor (dB)	Reading (dBuV)	Level (dBuV)	Limit (dBuV)	Margin (dB)	Detector
1	0.1660	10.13	42.48	52.61	65.15	-12.54	QP
2	0.1660	10.13	20.33	30.46	55.15	-24.69	AVG
3	0.1819	10.13	41.44	51.57	64.39	-12.82	QP
4	0.1819	10.13	22.18	32.31	54.39	-22.08	AVG
5	0.1980	10.13	40.21	50.34	63.69	-13.35	QP
6	0.1980	10.13	21.25	31.38	53.69	-22.31	AVG
7	0.2180	10.13	37.92	48.05	62.89	-14.84	QP
8	0.2180	10.13	19.65	29.78	52.89	-23.11	AVG
9	0.4740	10.15	32.79	42.94	56.44	-13.50	QP
10	0.4740	10.15	20.62	30.77	46.44	-15.67	AVG
11	18.2820	10.47	23.86	34.33	60.00	-25.67	QP
12	18.2820	10.47	15.80	26.27	50.00	-23.73	AVG

Note: Measurement Level = Reading Level + Correct Factor

Test engineer: Sun. Zhang



3.6. Test Photographs

Front View



Rear View





4. Test of Radiated Emission

4.1. Test Limit

Below 1GHz (for digital device)

For unintentional device, according to CISPR PUB.22, for Class B digital devices, the general requirement of field strength of radiated emissions from intentional radiators at a distance of 10 meters shall not exceed the below table.

FREQUENCY (MHz)	dBuV/m (At 10m)	
	Class A	Class B
30 ~ 230	40	30
230 ~ 1000	47	37

Limit tables for non-digital device:

Class A Radiated Emission limit at 10m (for others)

Frequency (MHz)	Field Strength Limit (uV/m)Q.P.	Field Strength Limit (dBuV/m)Q.P.
30 - 88	90	39
88 - 216	150	43.5
216 – 960	210	46.4
Above 960	300	49.5

Class B Radiated Emission limit at 3m (for others)

Frequency (MHz)	Field Strength Limit (uV/m)Q.P.	Field Strength Limit (dBuV/m)Q.P.
30 - 88	100	40
88 - 216	150	43.5
216 – 960	200	46
Above 960	500	54

Above 1GHz(for all device)

Frequency (MHz)	Class A (dBuV/m) (At 10m)		Class B (dBuV/m) (At 3m)	
	Average	Peak	Average	Peak
Above 1000	49.5	69.5	54	74

- NOTE:** (1) The lower limit shall apply at the transition frequencies.
 (2) Emission level (dBuV/m) = 20 log Emission level (uV/m).
 (3) The measurement above 1GHz is at close-in distances 3m, and determine the limit L2 corresponding to the close-in distance d2 by applying the following relation: $L2 = L1 (d1/d2)$, where L1 is the specified limit in microvolts per metre (uV/m) at the distance d1 (10m), L2 is the new limit for distance d2 (3m).
 So the new Class A limit above 1GHz at 3m is as following table:



Frequency (MHZ)	Class A (dBuV/m) (At 3m)	
	Average	Peak
Above 1000	60	80

According to FCC Part 15.33 (b), for an unintentional radiator, including a digital device, the spectrum shall be investigated from the lowest radio frequency signal generated or used in the device, without going below the lowest frequency for which a radiated emission limit is specified, up to the frequency shown in the following table:

Highest frequency generated or used in the device or on which the device operates or tunes (MHz)	Upper frequency of measurement range (MHz)
Below 1.75	30
1.75-108	1000
108-500	2000
500-1000	5000
Above 1000	5 th harmonic of the highest frequency or 40GHz, whichever is lower

4.2. Test Procedures

Procedure of Preliminary Test

- The equipment was set up as per the test configuration to simulate typical usage per the user's manual. When the EUT is a tabletop system, a wooden turntable with a height of 0.8 meters is used which is placed on the ground plane. When the EUT is a floor standing equipment, it is placed on the ground plane which has a 15 cm non-conductive covering to insulate the EUT from the ground plane.
- Support equipment, if needed, was placed as per ANSI C63.4.
- All I/O cables were positioned to simulate typical usage as per ANSI C63.4.
- The EUT received AC 120VAC/60Hz power source from the outlet socket under the turntable. All support equipment power received from another socket under the turntable.
- The antenna was placed at 3 or 10 meter away from the EUT as stated in ANSI C63.4. The antenna connected to the Spectrum Analyzer via a cable and at times a pre-amplifier would be used.
- The Analyzer / Receiver quickly scanned from 30MHz to 40GHz. The EUT test program was started. Emissions were scanned and measured rotating the EUT to 360 degrees and positioning the antenna 1 to 4 meters above the ground plane, in both the vertical and the horizontal polarization, to maximize the emission reading level.



- Set the spectrum analyzer/ Receiver in the following setting as:
Below 1GHz:
RBW=120KHz / VBW=300KHz / Sweep=AUTO
Above 1GHz:
Peak: RBW=1MHz, VBW=3MHz / Sweep=AUTO
Average: RBW=1MHz / VBW=10Hz / Sweep=AUTO
- The worst configuration of EUT and cable of the above highest emission level were recorded for reference of the final test.

Procedure of Final Test

- EUT and support equipment were set up on the turntable as per the configuration with highest emission level in the preliminary test.
- The Analyzer / Receiver scanned from 30MHz to 40GHz. Emissions were scanned and measured rotating the EUT to 360 degrees, varying cable placement and positioning the antenna 1 or 1 to 4 meters above the ground plane, in both the vertical and the horizontal polarization, to maximize the emission reading level.
- Recording at least the six highest emissions. Emission frequency, amplitude, antenna position, polarization and turntable position were recorded into a computer in which correction factors were used to calculate the emission level and compare reading to the applicable limit. Below 1GHz the Q.P. reading and above 1GHz the Peak and Average reading are presented.
- The test data of the worst-case condition(s) was recorded.

4.3. Typical test Setup

Below 1GHz Test Setup

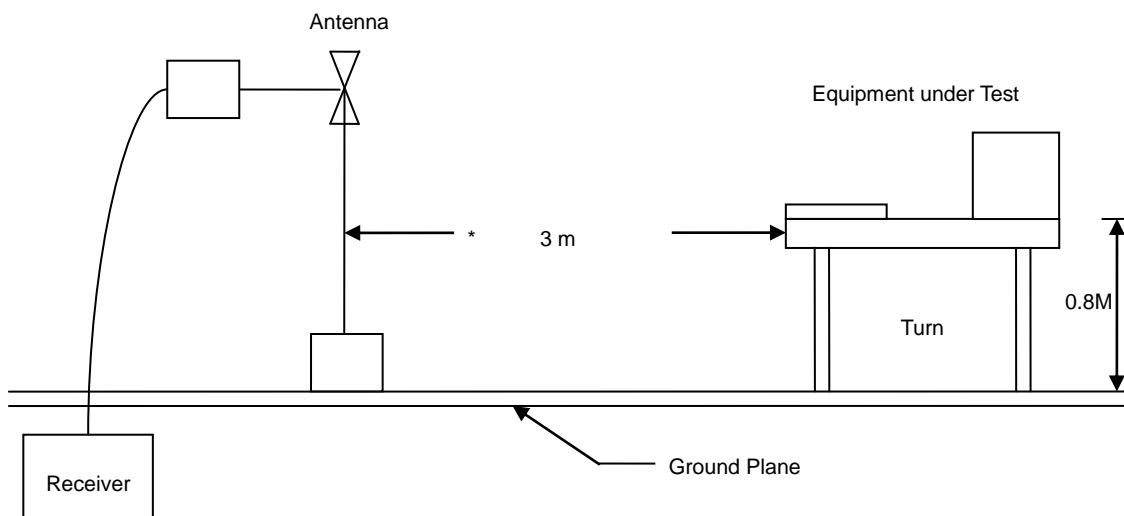



Above 1GHz Test Setup

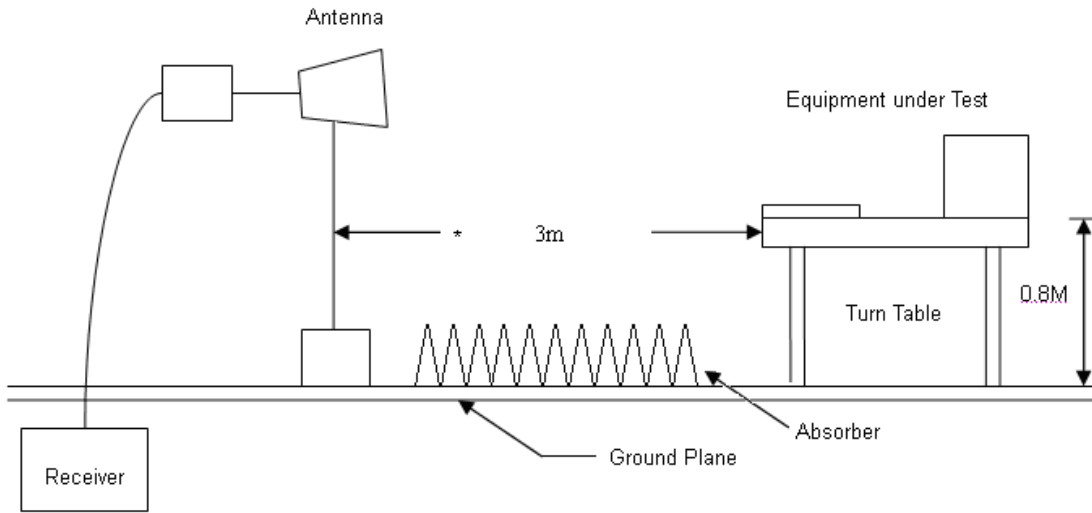

4.4. Measurement Equipment

Instrument/Ancillary	Manufacturer	Model No.	Serial No.	Calibration Date	Valid Date.
EMI Test Receiver	R&S	ESCI	101183	2016.06.29	2017.06.28
Preamplifier	songyi	EM330	60618	2016.03.26	2017.03.25
Preamplifier	Agilent	8449B	3008A02342	2016.03.26	2017.03.25
Bilog Antenna	Sunol Science	JB1	A072414-1	2016.04.16	2017.04.15
Broad-Band Horn Antenna	Schwarzbeck	BBHA9120D	9120D-618	2016.04.16	2017.04.15
Broad-Band Horn Antenna	Schwarzbeck	BBHA9170	9170-347	2016.04.16	2017.04.15
Preamplifier	COM-POWER	PA-840	711885	2016.03.26	2017.03.25
Spectrum Analyzer	R&S	FSP40	100324	2016.08.02	2017.08.01
Temperature/ Humidity Meter	Zhicheng	ZC1-11	CEP-TH-002	2016.03.29	2017.03.28
EZ-EMC	Fala	Ver CT3A1	N/A	N/A	N/A



4.5. Test Result and Data (30MHz~1GHz)

Test Mode :	Mode 1: Full System power from YLPS052000B-US Adapter		
AC Power :	AC 120V/60Hz	Ant. Polarization:	Horizontal
Equipment :	Media IP Phone	Model No :	SIP-T52S
Temp :	22°C	Humidity :	53%
Pressure(mbar) :	1002	Date :	2017/02/22

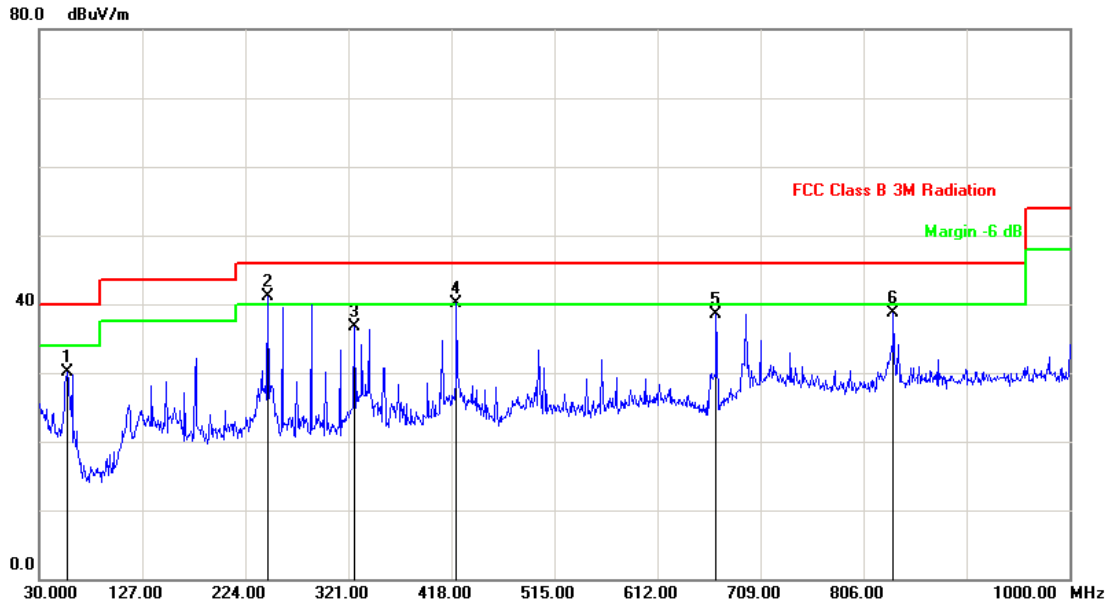

No.	Frequency (MHz)	Factor (dB/m)	Reading (dBuV)	Level (dBuV/m)	Limit (dBuV/m)	Margin (dB)	Det.	Height (cm)	Azimuth (deg)
1	56.1899	-12.02	42.17	30.15	40.00	-9.85	peak	100	21
2	245.3400	-11.45	52.50	41.05	46.00	-4.95	peak	100	54
3	326.8199	-6.36	43.07	36.71	46.00	-9.29	peak	100	4
4	422.8500	-3.58	43.64	40.06	46.00	-5.94	peak	200	65
5	667.2898	-1.94	40.37	38.43	46.00	-7.57	peak	200	156
6	834.1299	1.31	37.36	38.67	46.00	-7.33	peak	100	18

Note: Measurement Level = Reading Level + Correct Factor

Test Mode :	Mode 1: Full System power from YLPS052000B-US Adapter
-------------	---



AC Power :	AC 120V/60Hz	Ant. Polarization:	Vertical
Equipment :	Media IP Phone	Model No :	SIP-T52S
Temp :	22°C	Humidity :	53%
Pressure(mbar) :	1002	Date :	2017/02/22

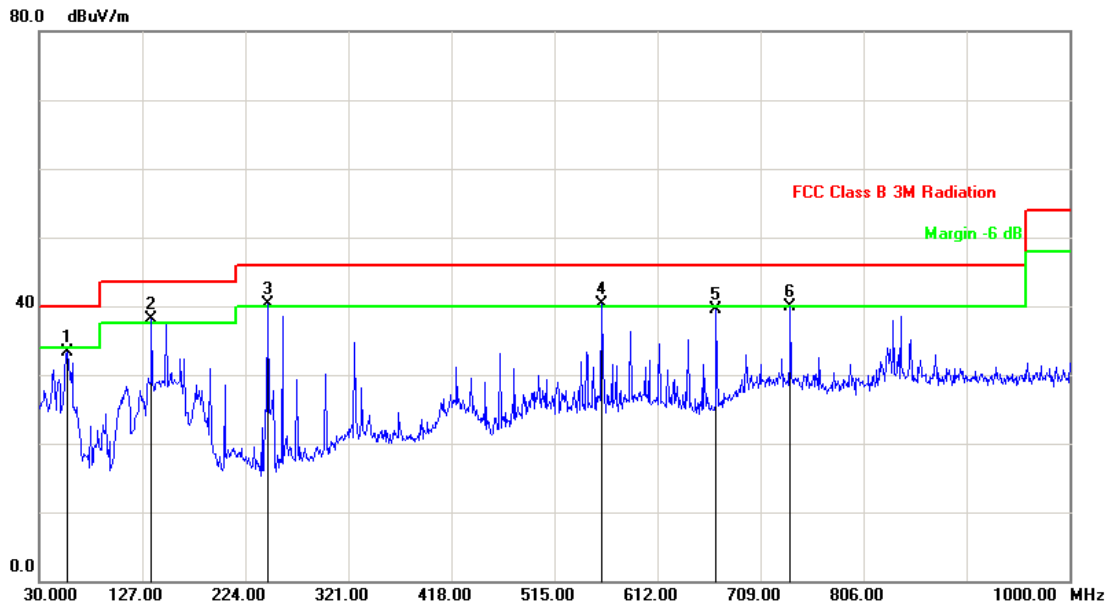

No.	Frequency (MHz)	Factor (dB/m)	Reading (dBuV)	Level (dBuV/m)	Limit (dBuV/m)	Margin (dB)	Det.	Height (cm)	Azimuth (deg)
1	56.1899	-12.02	45.39	33.37	40.00	-6.63	peak	100	6
2	135.7298	-8.25	46.43	38.18	43.50	-5.32	peak	100	65
3	245.3400	-11.45	51.70	40.25	46.00	-5.75	peak	100	59
4	559.6200	-3.32	43.58	40.26	46.00	-5.74	peak	200	65
5	667.2898	-1.94	41.48	39.54	46.00	-6.46	peak	200	304
6	737.1299	1.60	38.26	39.86	46.00	-6.14	peak	100	59

Note: Measurement Level = Reading Level + Correct Factor

Test Mode :	Mode 2: Full System power from YLPS052000C-US Adapter
-------------	---



AC Power :	AC 120V/60Hz	Ant. Polarization:	Horizontal
Equipment :	Media IP Phone	Model No :	SIP-T52S
Temp :	22°C	Humidity :	53%
Pressure(mbar) :	1002	Date :	2017/02/22

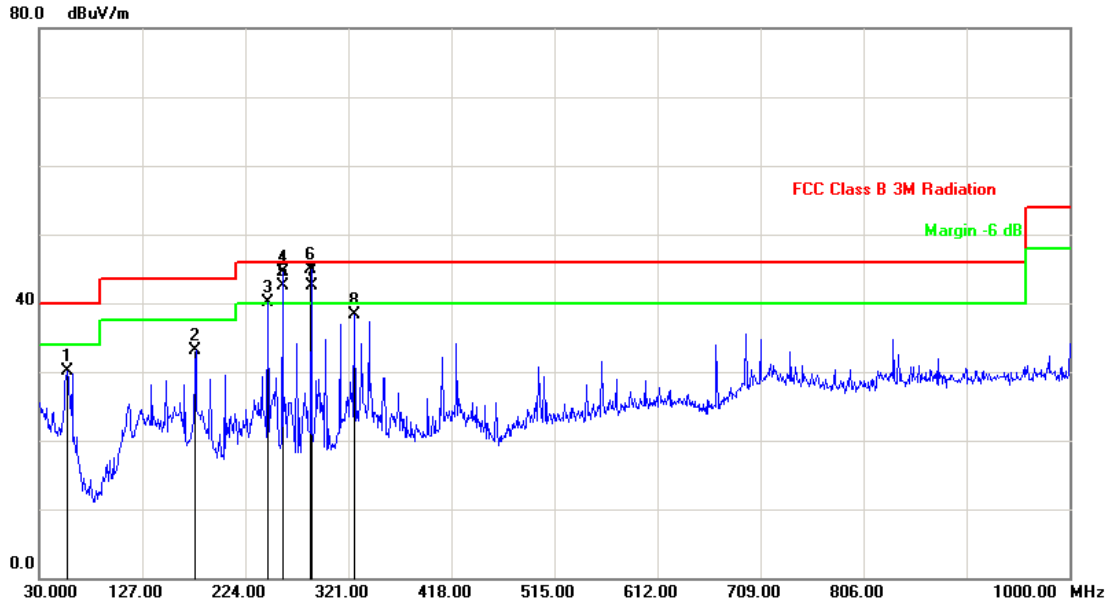

No.	Frequency (MHz)	Factor (dB/m)	Reading (dBuV)	Level (dBuV/m)	Limit (dBuV/m)	Margin (dB)	Det.	Height (cm)	Azimuth (deg)
1	56.1899	-12.02	42.17	30.15	40.00	-9.85	peak	100	273
2	177.4399	-7.64	40.67	33.03	43.50	-10.47	peak	100	179
3	245.3400	-11.45	51.50	40.05	46.00	-5.95	peak	100	28
4	258.9200	-10.25	54.68	44.43	46.00	-1.57	peak	100	108
5	259.3700	-10.21	52.76	42.55	46.00	-3.45	QP	100	108
6	286.0799	-8.77	53.67	44.90	46.00	-1.10	peak	100	234
7	287.1400	-8.73	51.20	42.47	46.00	-3.53	QP	100	234
8	326.8199	-6.36	44.57	38.21	46.00	-7.79	peak	100	199

Note: Measurement Level = Reading Level + Correct Factor

Test Mode :	Mode 2: Full System power from YLPS052000C-US Adapter
-------------	---



AC Power :	AC 120V/60Hz	Ant. Polarization:	Vertical
Equipment :	Media IP Phone	Model No :	SIP-T52S
Temp :	22°C	Humidity :	53%
Pressure(mbar) :	1002	Date :	2017/02/22

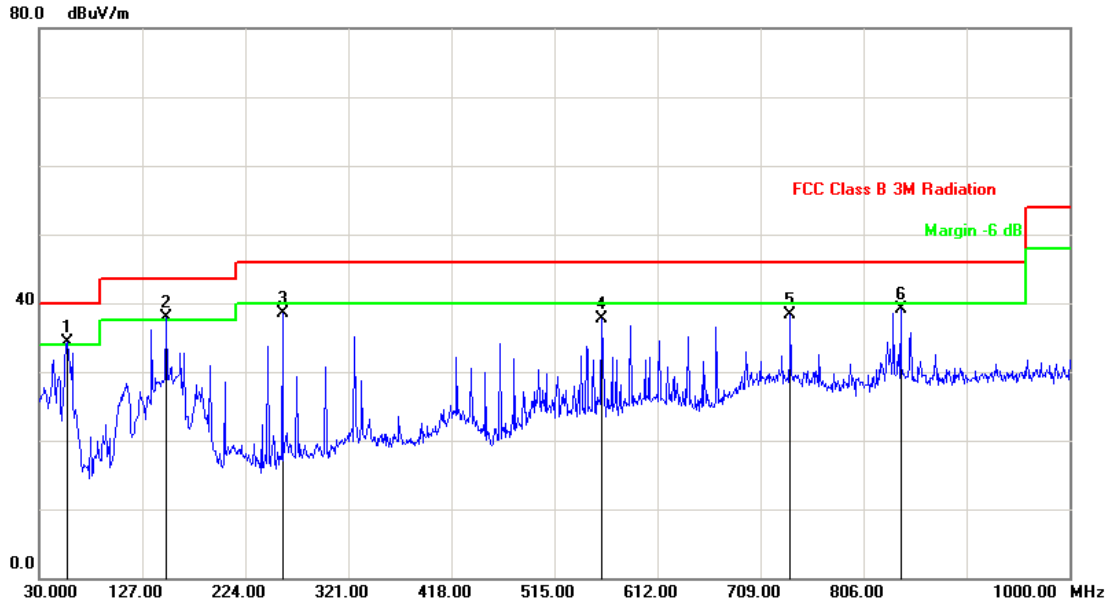

No.	Frequency (MHz)	Factor (dB/m)	Reading (dBuV)	Level (dBuV/m)	Limit (dBuV/m)	Margin (dB)	Det.	Height (cm)	Azimuth (deg)
1	56.1900	-12.02	46.39	34.37	40.00	-5.63	peak	100	204
2	149.3100	-7.67	45.48	37.81	43.50	-5.69	peak	100	320
3	258.9200	-10.25	48.84	38.59	46.00	-7.41	peak	100	311
4	559.6200	-3.32	41.08	37.76	46.00	-8.24	peak	100	130
5	737.1300	1.60	36.76	38.36	46.00	-7.64	peak	100	359
6	840.9200	1.47	37.56	39.03	46.00	-6.97	peak	100	35

Note: Measurement Level = Reading Level + Correct Factor

Test Mode :	Mode 3: Full System power from POE Switch
-------------	---



DC Power :	POE 48V	Ant. Polarization:	Horizontal
Equipment :	Media IP Phone	Model No :	SIP-T52S
Temp :	22°C	Humidity :	53%
Pressure(mbar) :	1002	Date :	2017/02/22

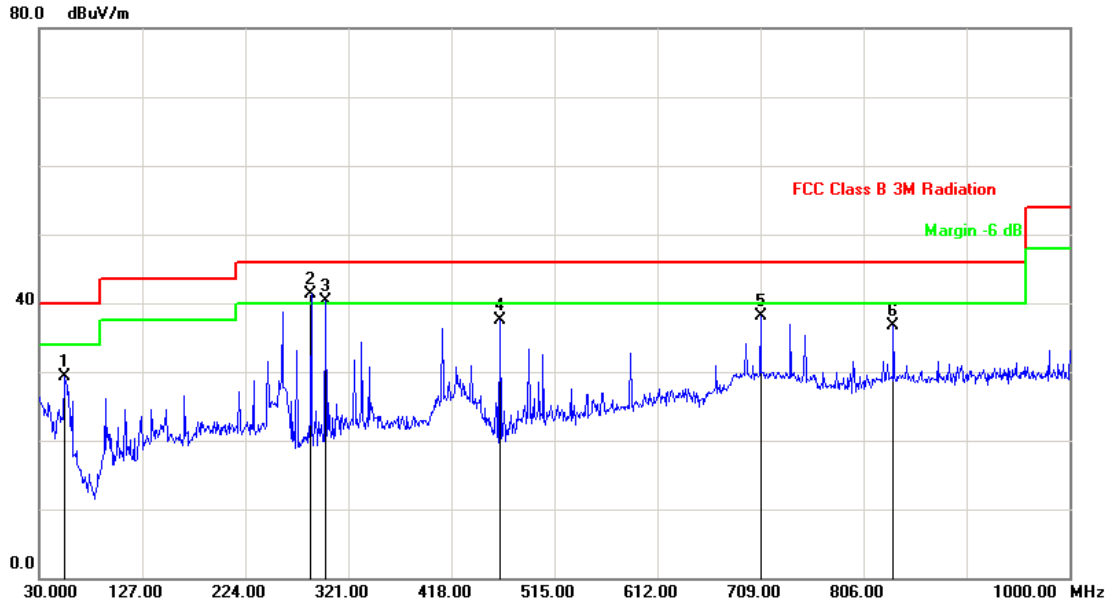

No.	Frequency (MHz)	Factor (dB/m)	Reading (dBuV)	Level (dBuV/m)	Limit (dBuV/m)	Margin (dB)	Det.	Height (cm)	Azimuth (deg)
1	53.2800	-11.53	40.85	29.32	40.00	-10.68	peak	100	72
2	286.0799	-8.77	50.00	41.23	46.00	-4.77	peak	100	292
3	299.6600	-8.29	48.60	40.31	46.00	-5.69	peak	100	257
4	463.5899	-7.29	44.86	37.57	46.00	-8.43	peak	100	303
5	709.0000	1.24	36.91	38.15	46.00	-7.85	peak	100	137
6	834.1299	1.31	35.48	36.79	46.00	-9.21	peak	100	122

Note: Measurement Level = Reading Level + Correct Factor

Test Mode :	Mode 3: Full System power from POE Switch
-------------	---



DC Power :	POE 48V	Ant. Polarization:	Vertical
Equipment :	Media IP Phone	Model No :	SIP-T52S
Temp :	22°C	Humidity :	53%
Pressure(mbar) :	1002	Date :	2017/02/22

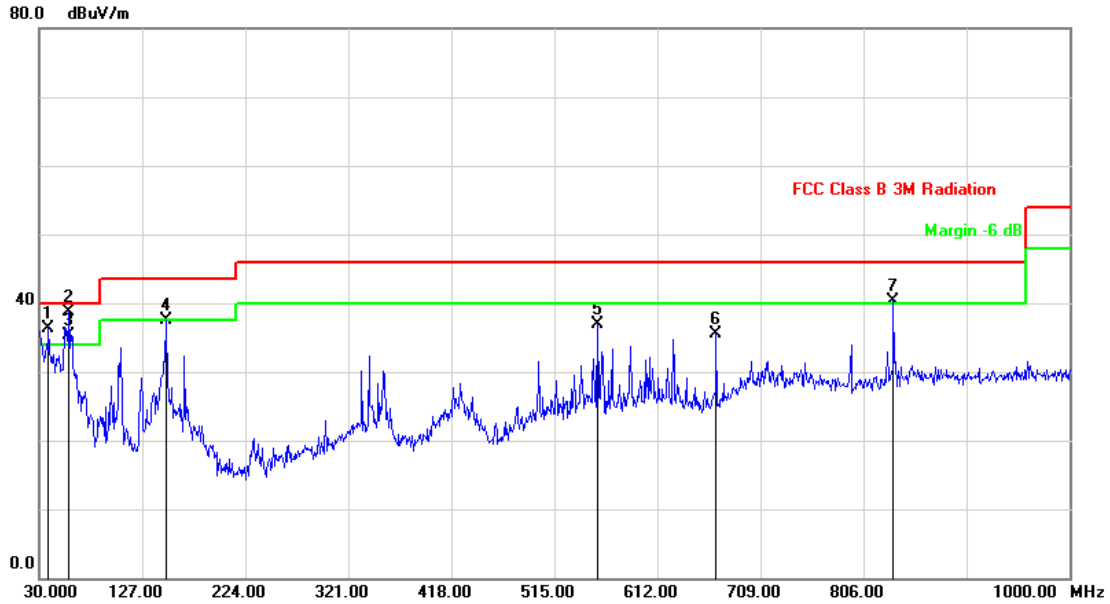

No.	Frequency (MHz)	Factor (dB/m)	Reading (dBuV)	Level (dBuV/m)	Limit (dBuV/m)	Margin (dB)	Det.	Height (cm)	Azimuth (deg)
1	38.7300	-5.77	42.09	36.32	40.00	-3.68	peak	100	17
2	58.1300	-12.35	51.06	38.71	40.00	-1.29	peak	100	128
3	58.1420	-12.35	47.56	35.21	40.00	-4.79	QP	100	120
4	149.3100	-7.67	45.11	37.44	43.50	-6.06	peak	100	17
5	555.7400	-3.46	40.32	36.86	46.00	-9.14	peak	100	101
6	667.2900	-1.94	37.44	35.50	46.00	-10.50	peak	100	237
7	834.1300	1.31	39.09	40.40	46.00	-5.60	peak	100	351

Note: Measurement Level = Reading Level + Correct Factor



4.6. Test Result and Data (1GHz ~6GHz)

Test Mode :	Mode 1: Full System power from YLPS052000B-US Adapter		
AC Power :	AC 120V/60Hz	Ant. Polarization:	Horizontal
Equipment :	Media IP Phone	Model No :	SIP-T52S
Temp :	22°C	Humidity :	53%
Pressure(mbar) :	1002	Date :	2017/02/22

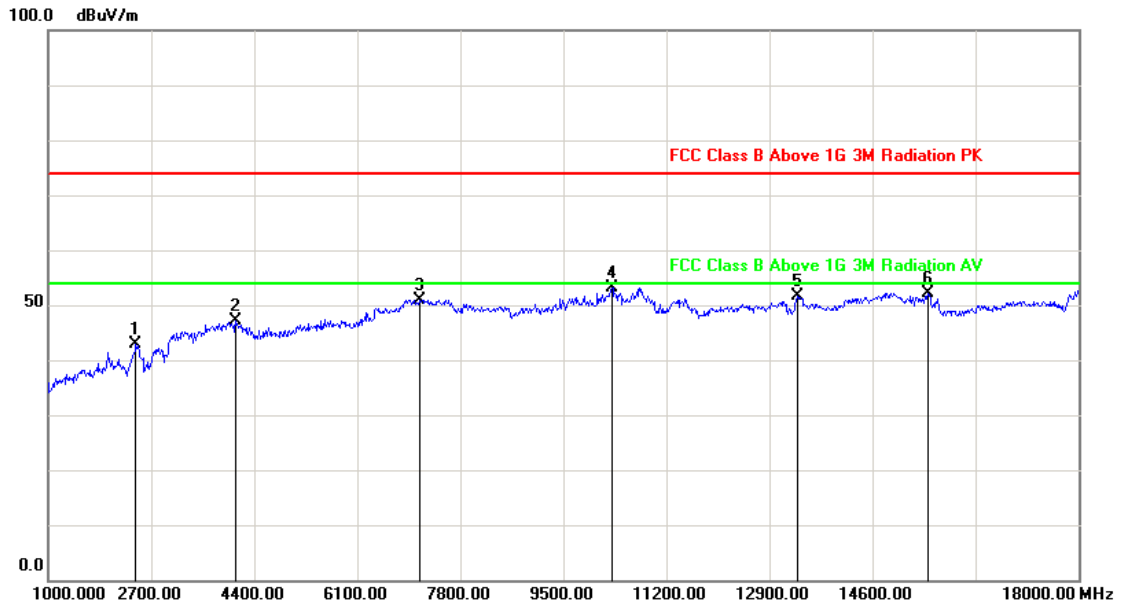

No.	Frequency (MHz)	Factor (dB/m)	Reading (dBuV)	Level (dBuV/m)	Limit (dBuV/m)	Margin (dB)	Det.	Height (cm)	Azimuth (deg)
1	2445.000	-2.04	44.85	42.81	74.00	-31.19	peak	100	256
2	4094.000	3.31	43.74	47.05	74.00	-26.95	peak	100	360
3	7137.000	8.15	42.80	50.95	74.00	-23.05	peak	100	67
4	10299.000	11.51	41.72	53.23	74.00	-20.77	peak	100	248
5	13359.000	17.85	33.85	51.70	74.00	-22.30	peak	100	36
6	15518.000	21.90	30.11	52.01	74.00	-21.99	peak	100	303

Note: Measurement Level = Reading Level + Correct Factor

Test Mode :	Mode 1: Full System power from YLPS052000B-US Adapter
-------------	---



AC Power :	AC 120V/60Hz	Ant. Polarization:	Vertical
Equipment :	Media IP Phone	Model No :	SIP-T52S
Temp :	22°C	Humidity :	53%
Pressure(mbar) :	1002	Date :	2017/02/22

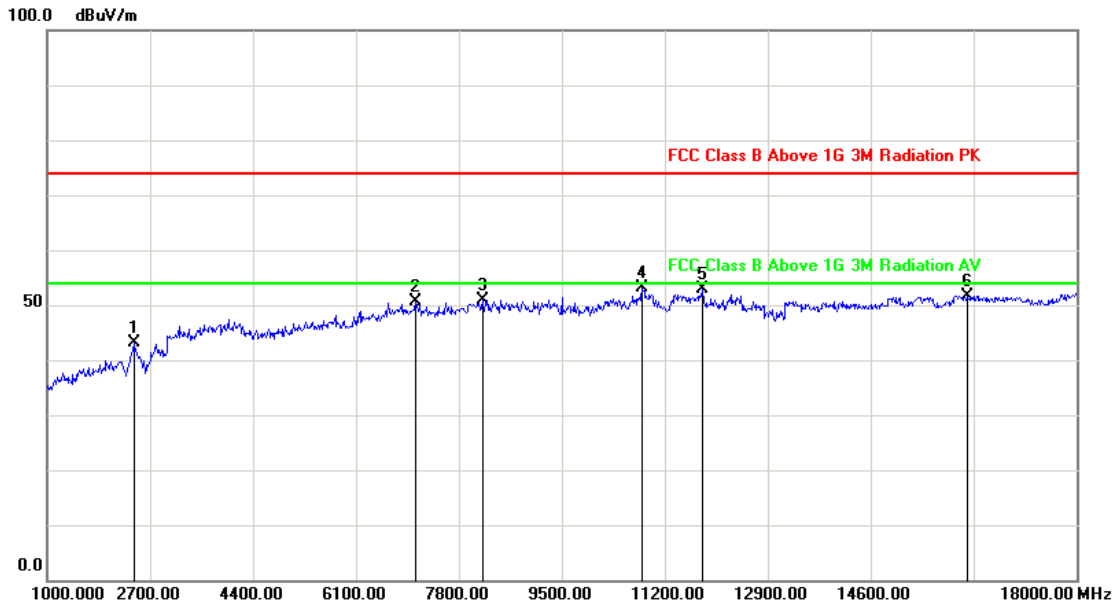

No.	Frequency (MHz)	Factor (dB/m)	Reading (dBuV)	Level (dBuV/m)	Limit (dBuV/m)	Margin (dB)	Det.	Height (cm)	Azimuth (deg)
1	2428.000	-2.10	45.26	43.16	74.00	-30.84	peak	100	36
2	7086.000	8.11	42.49	50.60	74.00	-23.40	peak	100	133
3	8191.000	9.12	41.81	50.93	74.00	-23.07	peak	100	74
4	10826.000	12.45	40.72	53.17	74.00	-20.83	peak	100	198
5	11829.000	12.09	40.87	52.96	74.00	-21.04	peak	100	0
6	16198.000	14.76	36.99	51.75	74.00	-22.25	peak	100	0

Note: Measurement Level = Reading Level + Correct Factor

Test Mode :	Mode 2: Full System power from YLPS052000C-US Adapter
-------------	---



AC Power :	AC 120V/60Hz	Ant. Polarization:	Horizontal
Equipment :	Media IP Phone	Model No :	SIP-T52S
Temp :	22°C	Humidity :	53%
Pressure(mbar) :	1002	Date :	2017/02/22

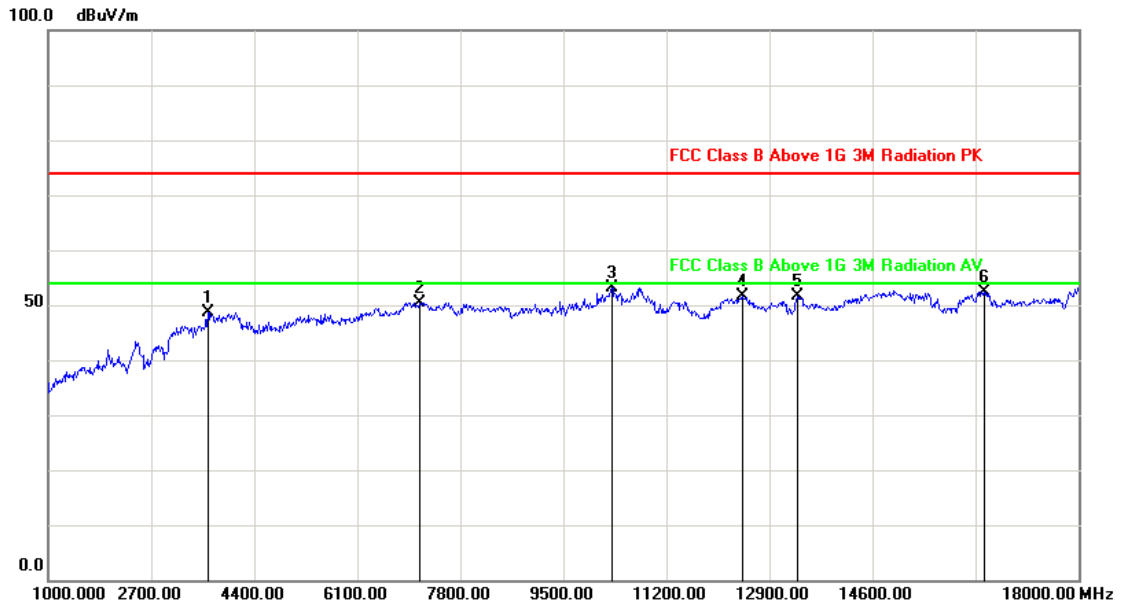

No.	Frequency (MHz)	Factor (dB/m)	Reading (dBuV)	Level (dBuV/m)	Limit (dBuV/m)	Margin (dB)	Det.	Height (cm)	Azimuth (deg)
1	3635.000	2.07	46.61	48.68	74.00	-25.32	peak	100	21
2	7137.000	8.15	42.30	50.45	74.00	-23.55	peak	100	55
3	10299.000	11.51	41.72	53.23	74.00	-20.77	peak	200	265
4	12458.000	13.53	38.19	51.72	74.00	-22.28	peak	100	0
5	13359.000	17.85	33.85	51.70	74.00	-22.30	peak	200	314
6	16436.000	14.80	37.69	52.49	74.00	-21.51	peak	100	59

Note: Measurement Level = Reading Level + Correct Factor

Test Mode :	Mode 2: Full System power from YLPS052000C-US Adapter
-------------	---



AC Power :	AC 120V/60Hz	Ant. Polarization:	Vertical
Equipment :	Media IP Phone	Model No :	SIP-T52S
Temp :	22°C	Humidity :	53%
Pressure(mbar) :	1002	Date :	2017/02/22

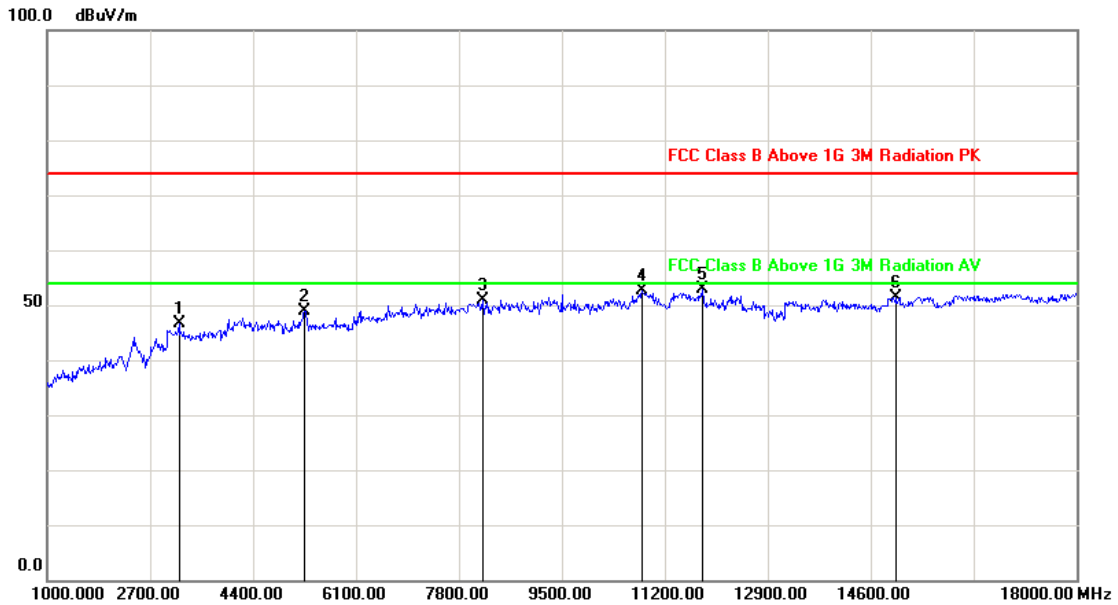

No.	Frequency (MHz)	Factor (dB/m)	Reading (dBuV)	Level (dBuV/m)	Limit (dBuV/m)	Margin (dB)	Det.	Height (cm)	Azimuth (deg)
1	3176.000	0.18	46.33	46.51	74.00	-27.49	peak	100	58
2	5250.000	4.43	44.49	48.92	74.00	-25.08	peak	100	25
3	8191.000	9.12	41.81	50.93	74.00	-23.07	peak	100	45
4	10826.000	12.45	40.22	52.67	74.00	-21.33	peak	100	208
5	11829.000	12.09	40.87	52.96	74.00	-21.04	peak	200	345
6	15008.000	22.45	29.01	51.46	74.00	-22.54	peak	200	159

Note: Measurement Level = Reading Level + Correct Factor

Test Mode :	Mode 3: Full System power from POE Switch
-------------	---



DC Power :	POE 48V	Ant. Polarization:	Horizontal
Equipment :	Media IP Phone	Model No :	SIP-T52S
Temp :	22°C	Humidity :	53%
Pressure(mbar) :	1002	Date :	2017/02/22

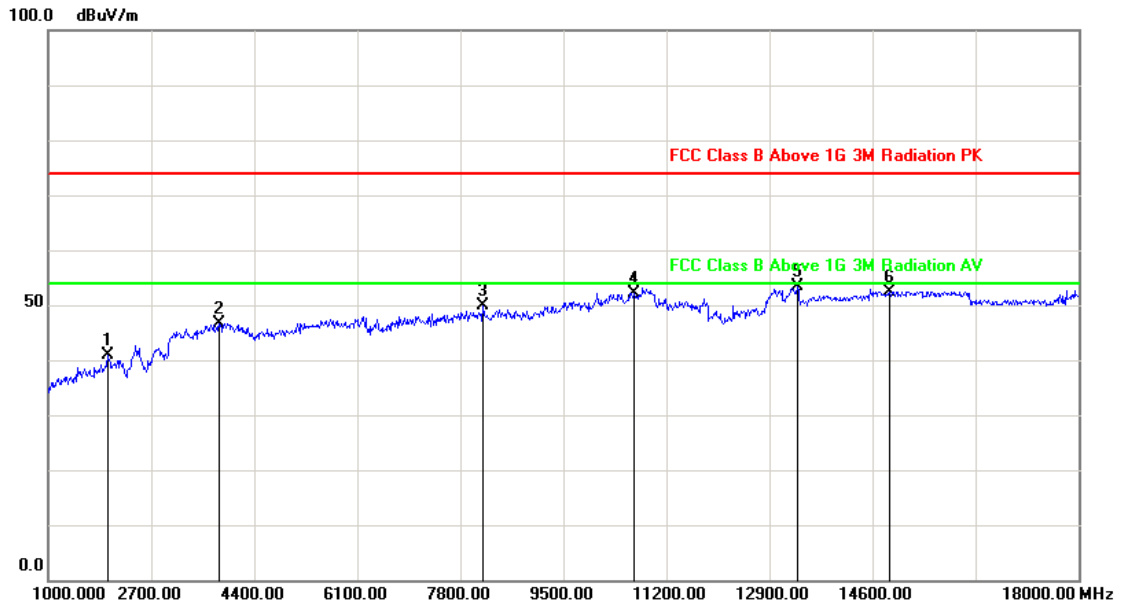

No.	Frequency (MHz)	Factor (dB/m)	Reading (dBuV)	Level (dBuV/m)	Limit (dBuV/m)	Margin (dB)	Det.	Height (cm)	Azimuth (deg)
1	1986.000	-3.76	44.68	40.92	74.00	-33.08	peak	100	209
2	3822.000	2.78	43.82	46.60	74.00	-27.40	peak	100	266
3	8174.000	9.13	40.81	49.94	74.00	-24.06	peak	100	71
4	10673.000	12.24	40.00	52.24	74.00	-21.76	peak	100	76
5	13359.000	17.85	35.46	53.31	74.00	-20.69	peak	100	100
6	14872.000	21.79	30.70	52.49	74.00	-21.51	peak	100	94

Note: Measurement Level = Reading Level + Correct Factor

Test Mode :	Mode 3: Full System power from POE Switch
-------------	---



DC Power :	POE 48V	Ant. Polarization:	Vertical
Equipment :	Media IP Phone	Model No :	SIP-T52S
Temp :	22°C	Humidity :	53%
Pressure(mbar) :	1002	Date :	2017/02/22

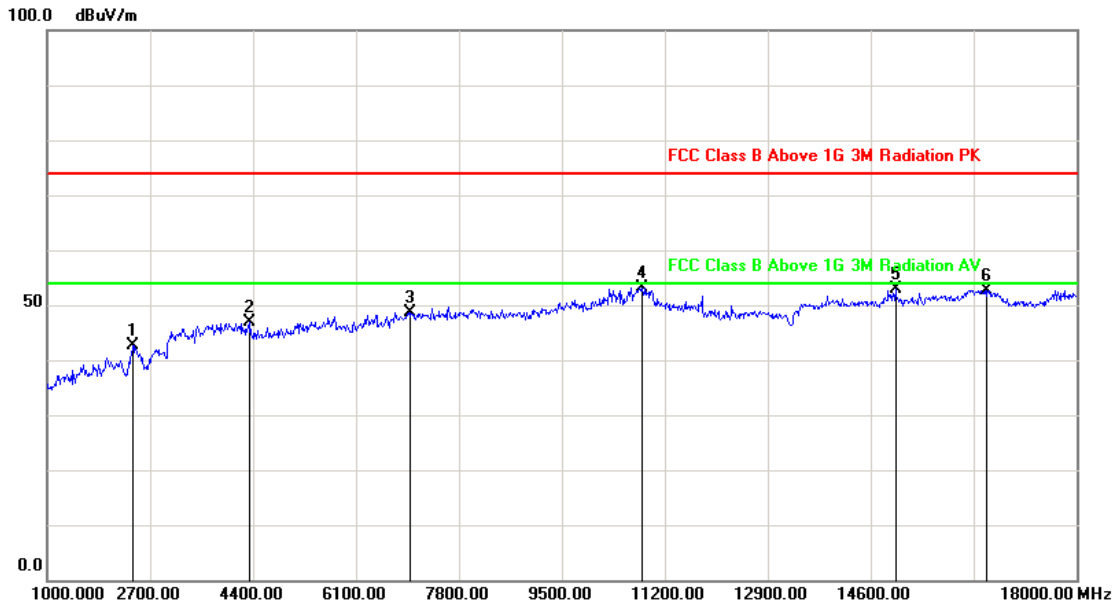

No.	Frequency (MHz)	Factor (dB/m)	Reading (dBuV)	Level (dBuV/m)	Limit (dBuV/m)	Margin (dB)	Det.	Height (cm)	Azimuth (deg)
1	2411.000	-2.16	44.80	42.64	74.00	-31.36	peak	100	210
2	4349.000	2.92	43.85	46.77	74.00	-27.23	peak	100	240
3	7001.000	8.05	40.63	48.68	74.00	-25.32	peak	100	358
4	10826.000	12.45	40.80	53.25	74.00	-20.75	peak	100	278
5	15008.000	22.45	30.49	52.94	74.00	-21.06	peak	100	0
6	16521.000	14.96	37.76	52.72	74.00	-21.28	peak	100	0

Note: Measurement Level = Reading Level + Correct Factor

Test engineer: Sun. Zhang



4.7. Test Photographs (30MHz ~ 1GHz)

MODE 1, 2

Front View

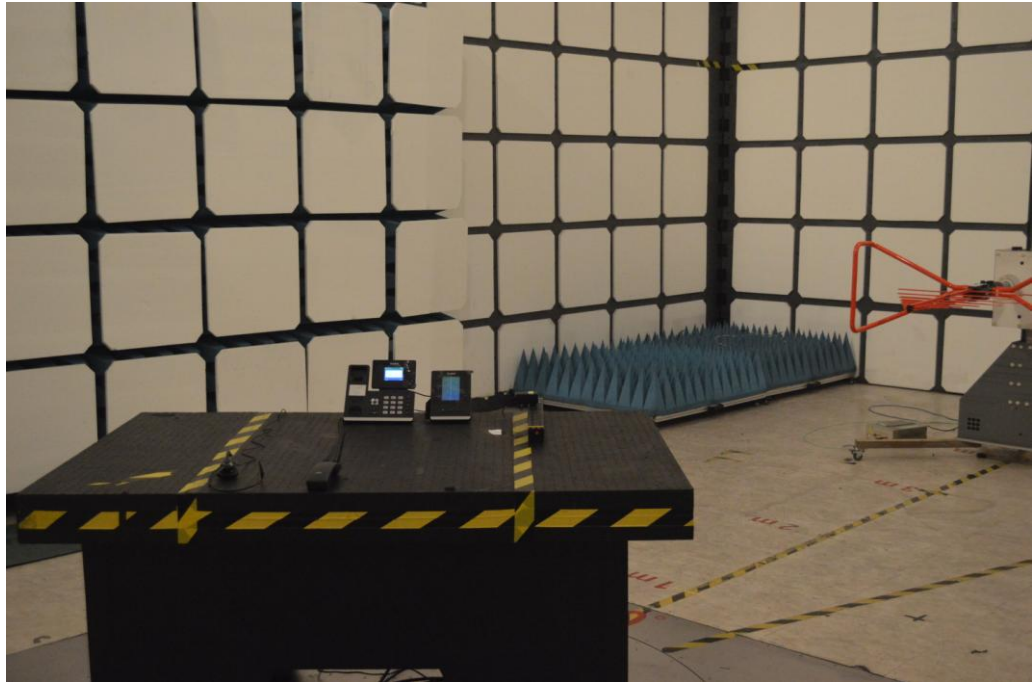

Rear View

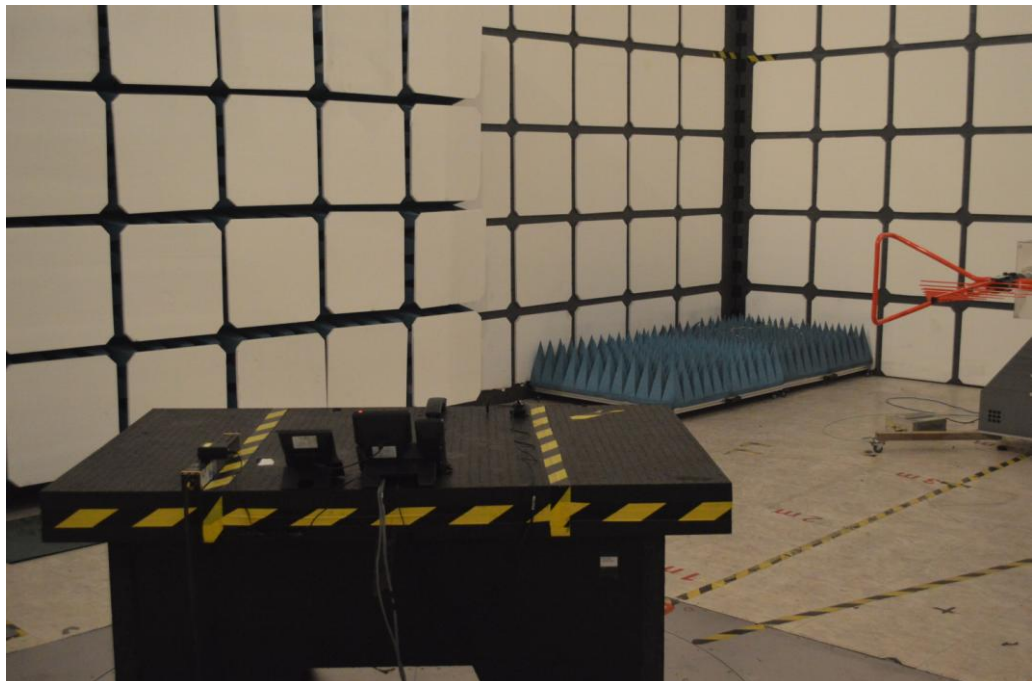

MODE 3



Front View

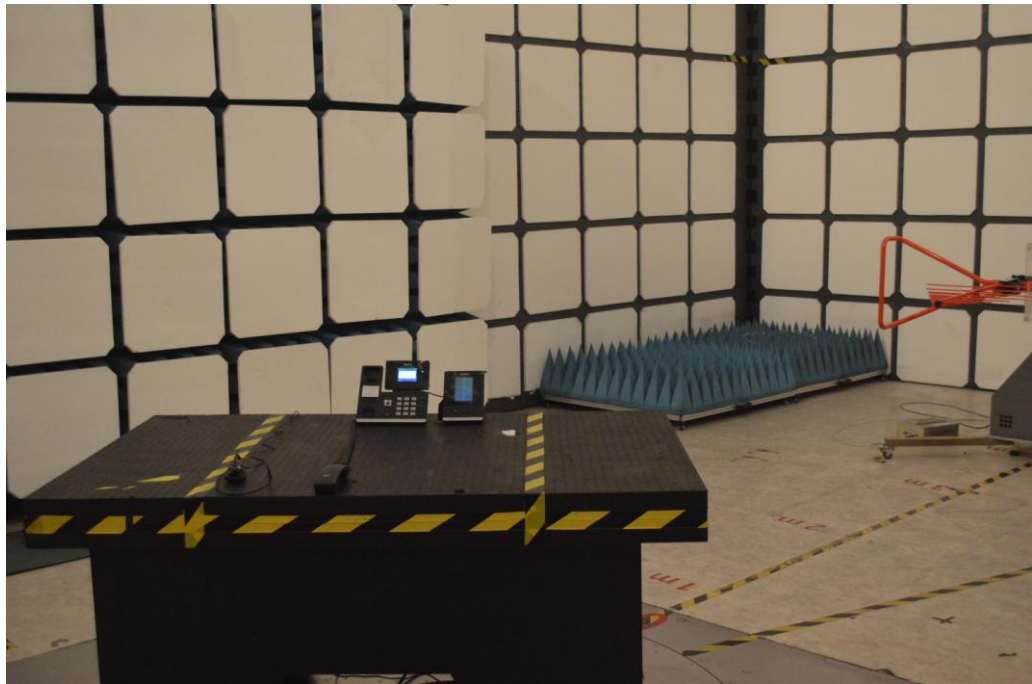

Rear View

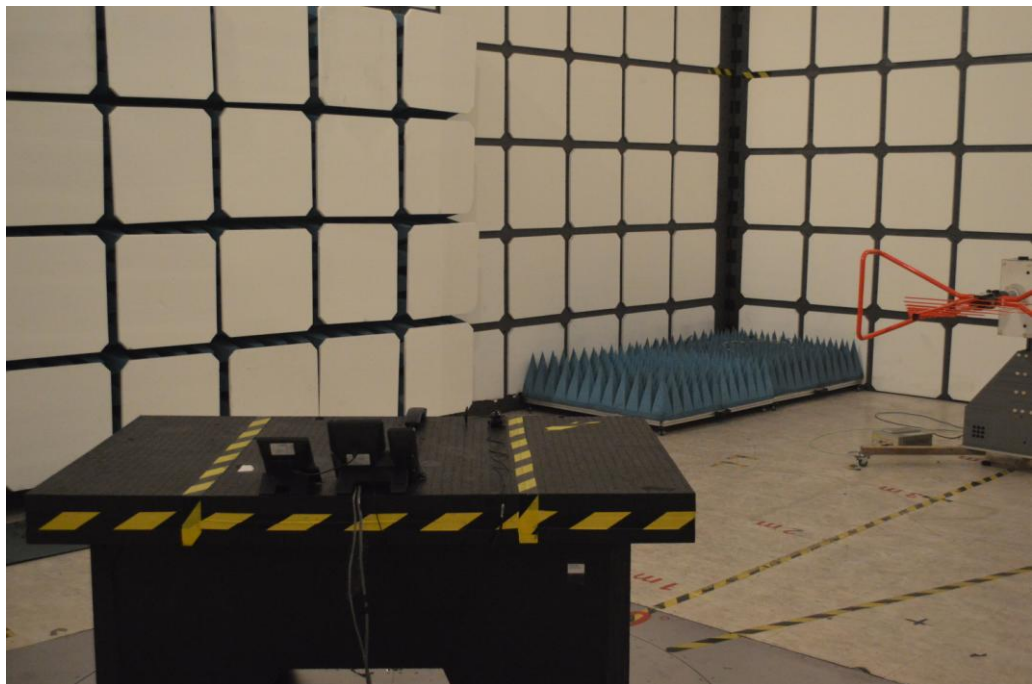



4.8. Test Photographs (1GHz ~ 6GHz)

MODE 1, 2

Front View

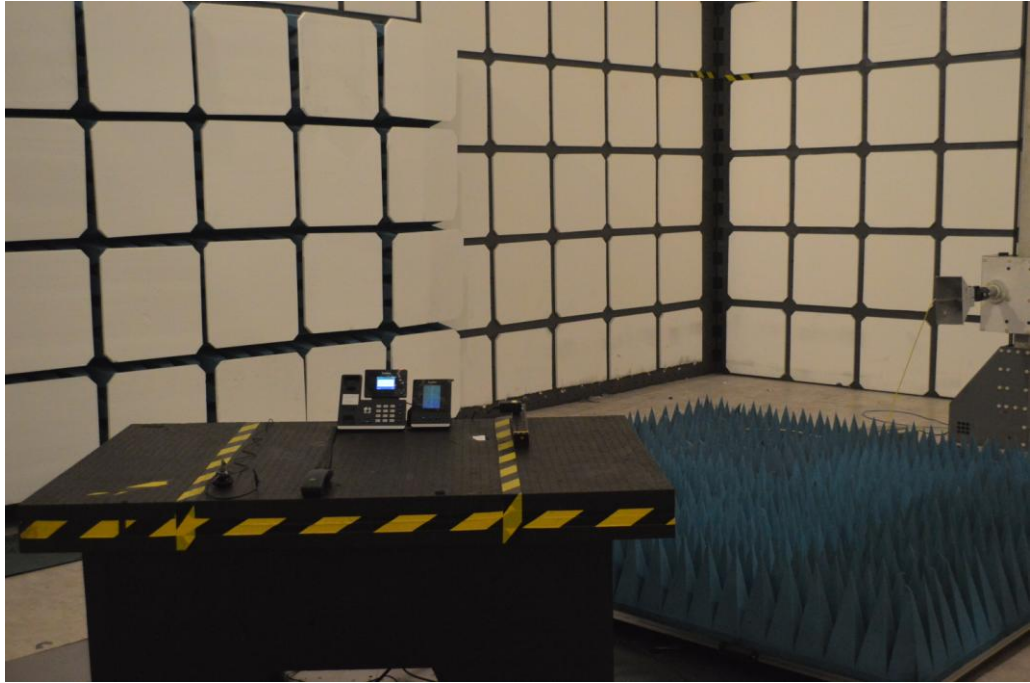

Rear View

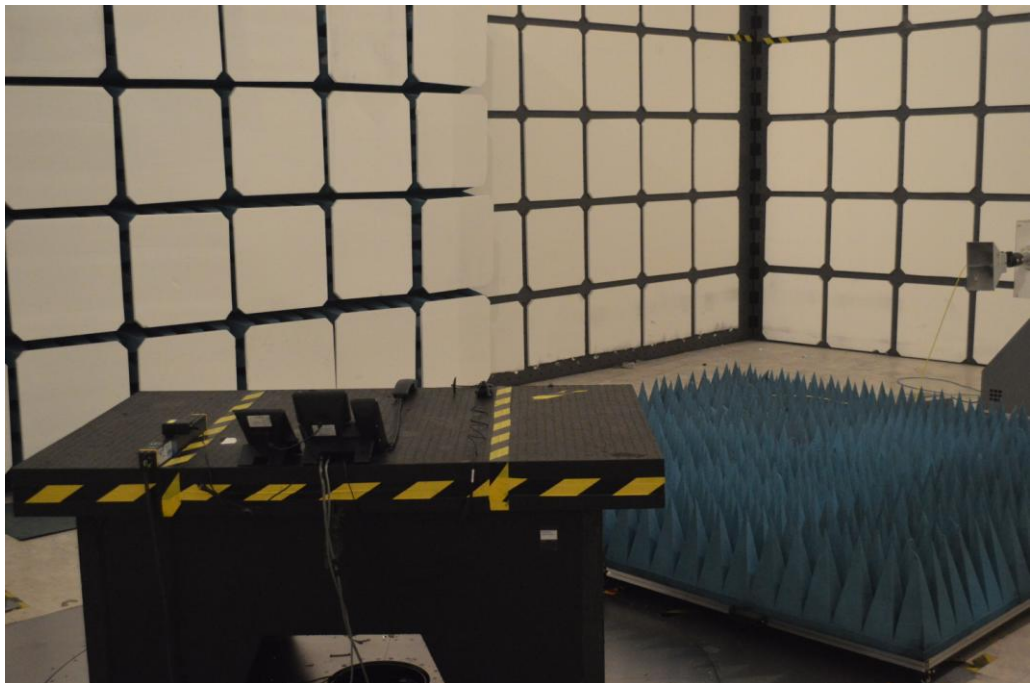



MODE 3

Front View

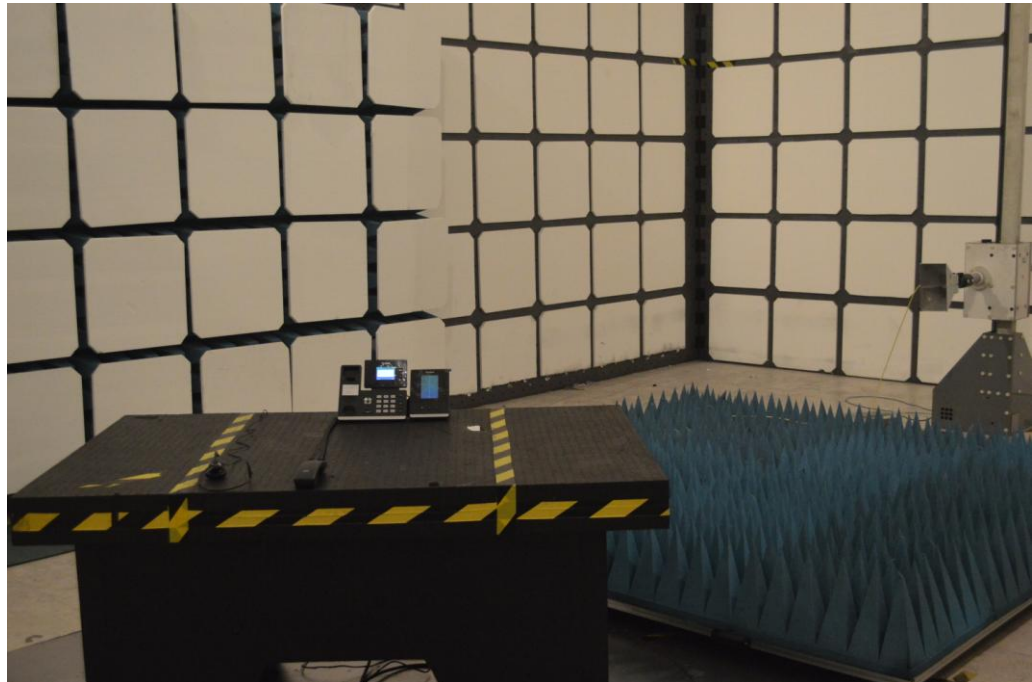

Rear View

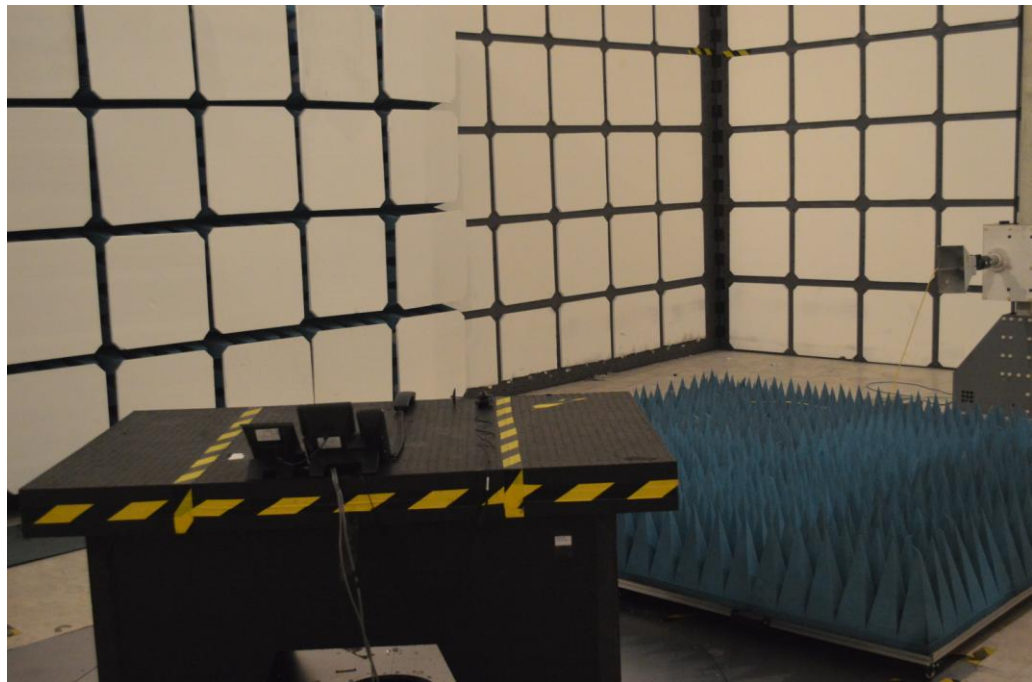



5. Photographs of EUT

1) EUT Photo



2) EUT Photo





3) EUT Photo



4) EUT Photo

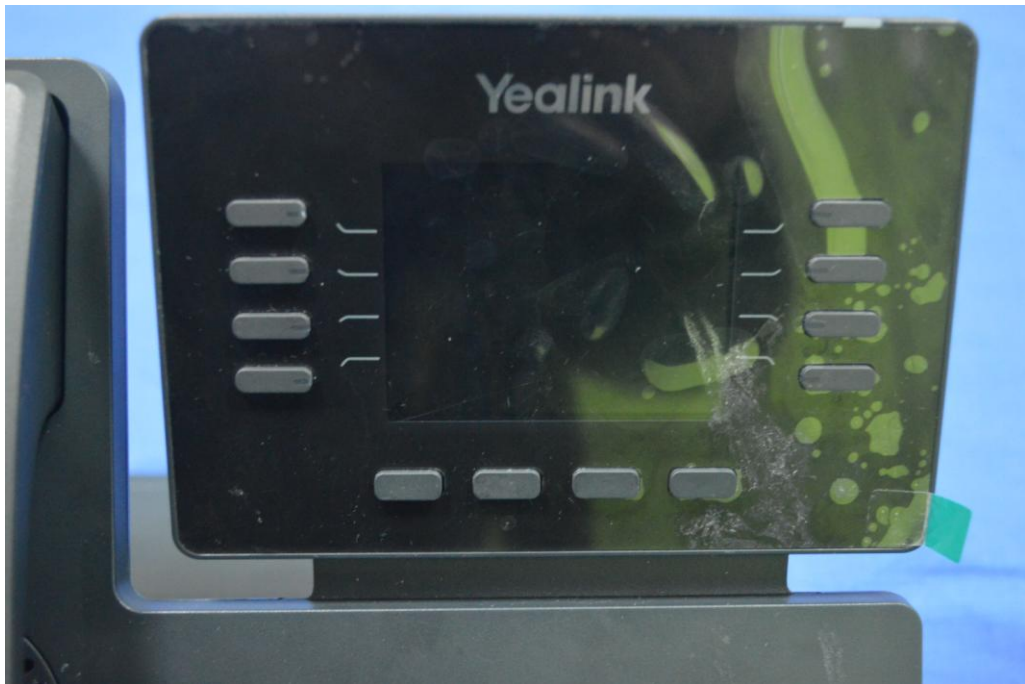



5) EUT Photo



6) EUT Photo





7) EUT Photo



8) EUT Photo





9) EUT Photo

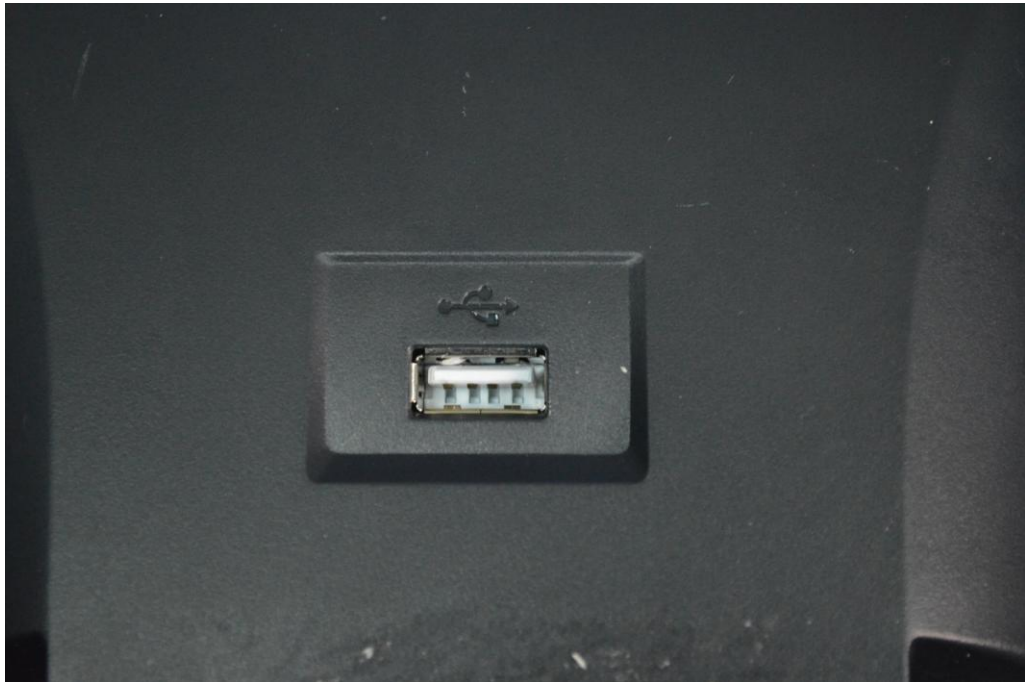

10) EUT Photo





11) EUT Photo(Adapter/ YLPS052000B-US)



12) EUT Photo





13) EUT Photo

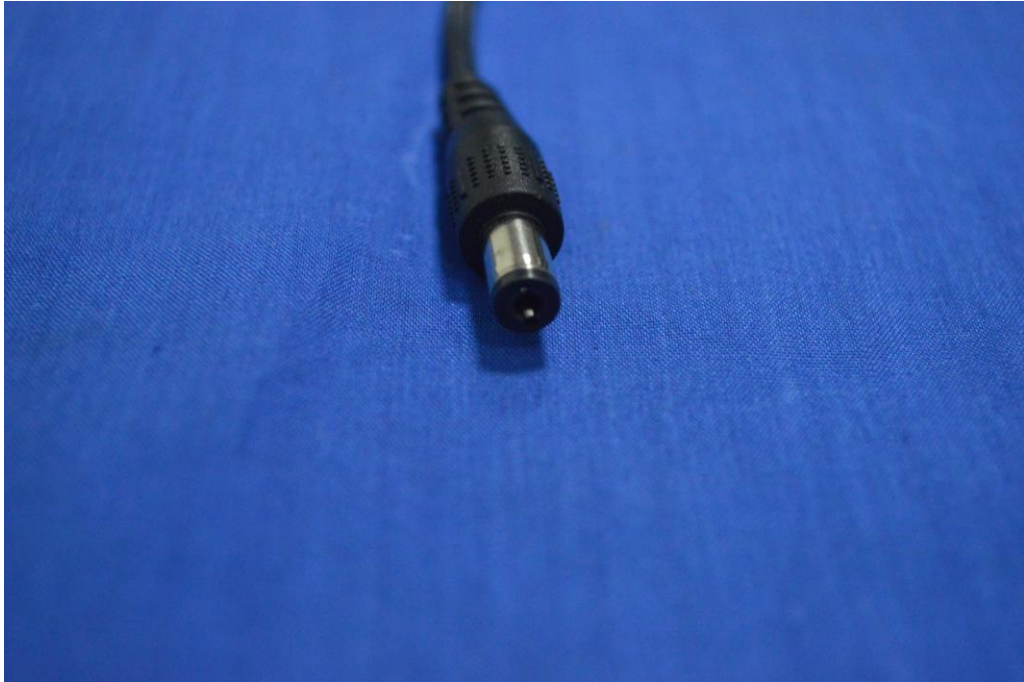

14) EUT Photo(Adapter/ YLPS052000C-US)





15) EUT Photo

