



**EUROFINS ELECTRICAL TESTING SERVICE (SHENZHEN) Co., LTD.**

# **RADIO TEST - REPORT**

**FCC&IC Compliance Test Report for**

**Product name: Wireless Presentation System**

**Model name: RoomCast**

**FCC ID: T2C-ROOMCAST**

**IC: 10741A-ROOMCAST**

**Test Report Number: EFGX21030184-IE-01-E09**

The above sample(s) and sample information was/were submitted and identified on behalf of the applicant.  
Eurofins assures objectivity and impartiality of the test, and fulfills the obligation of confidentiality for applicant's commercial information and technical documents.



Eurofins Electrical Testing Service (Shenzhen) Co., Ltd.  
1st Floor, Building 2, Chungu, Meisheng Huigu Science and Technology Park,  
No. 83 Dabao Road, Bao'an District, Shenzhen. P.R.China

Phone: +86-0755-829118671  
Fax: +86-0755-82910749

## Content

<b>1</b>	<b>General Information</b>	<b>4</b>
1.1	Notes	4
1.2	Testing laboratory	5
1.3	Details of applicant	5
1.4	Details of manufacturer	5
1.5	Application details	6
1.6	Test item	6
1.7	Test standards	7
<b>2</b>	<b>Technical test</b>	<b>8</b>
2.1	Summary of test results	8
2.2	Test environment	8
2.3	Measurement uncertainty	8
2.4	Test mode	9
2.5	Test equipment utilized	10
2.6	Auxiliary equipment used during test	11
2.7	Test software information	11
2.8	Test setup	12
2.9	Test results	14
<b>3</b>	<b>Technical Requirement</b>	<b>15</b>
3.1	Conducted emission AC power port	15
3.2	Duty cycle	16
3.3	6dB bandwidth	17
3.4	99% Occupied Bandwidth	18
3.5	26 dB Bandwidth	19
3.6	Maximum Conducted Output Power	20
3.7	Power spectral density	25
3.8	Transmitter radiated spurious emissionsr	27
<b>4</b>	<b>Test Setup Photos</b>	<b>31</b>
<b>5</b>	<b>External Photo</b>	<b>31</b>
<b>6</b>	<b>Internal Photos</b>	<b>31</b>



## 1 General Information

### 1.1 Notes

The results of this test report relate exclusively to the item tested as specified in chapter “Description of test item” and are not transferable to any other test items.

Eurofins Electrical Testing Service (Shenzhen) Co., Ltd. is not responsible for any generalisations and conclusions drawn from this report. Any modification of the test item can lead to invalidity of test results and this test report may therefore be not applicable to the modified test item.

The test report may only be reproduced or published in full. Reproducing or publishing extracts of the report requires the prior written approval of the Eurofins Electrical Testing Service (Shenzhen) Co., Ltd.

This document is subject to the General Terms and Conditions and the Testing and Certification System of Eurofins Electrical Testing Service (Shenzhen) Co., Ltd., available on request or accessible at [www.eurofins.com](http://www.eurofins.com).

#### Operator:

2021-06-30		Bruce Zheng / Project Engineer	
Date	Eurofins-Lab.	Name / Title	Signature

#### Technical responsibility for area of testing:

2021-06-30		Tom Tian / Supervisor	
Date	Eurofins	Name / Title	Signature

## 1.2 Testing laboratory

Eurofins Electrical Testing Service (Shenzhen) Co., Ltd.

1st Floor, Building 2, Chungu, Meisheng Huigu Science and Technology Park, No. 83 Dabao Road, Bao'an District, Shenzhen. P.R.China.

Telephone : +86-755-82911867

Fax : +86-755-82910749

The Laboratory has passed the Accreditation by the American Association for Laboratory Accreditation (A2LA). The Accreditation number is 5376.01

The Laboratory has been listed by industry Canada to perform electromagnetic emission measurements, The CAB identifier is CN0088

## 1.3 Details of applicant

Name : YEALINK(XIAMEN) NETWORK TECHNOLOGY CO.,LTD  
Address : 309, 3rd Floor, No.16, Yun Ding North Road, Huli District, Xiamen City, Fujian, P.R. China  
Telephone : ./.  
Fax : ./.

## 1.4 Details of manufacturer

Name : YEALINK(XIAMEN) NETWORK TECHNOLOGY CO.,LTD  
Address : 3rd -6th Floor, No.15 building, Golden Industrial Park, No.120 Hong Tang, Tong'an District, Xiamen City, Fujian, P.R. China  
Telephone : ./.  
Fax : ./.

## 1.5 Application details

Date of receipt of application : 2021-03-22  
 Date of receipt of test item : 2021-03-22  
 Date of test : 2021-03-22 to 2021-06-01  
 Date of issue : 2021-06-30

## 1.6 Test item

Product type : Wireless Presentation System  
 Model name : RoomCast  
 Brand : YEALINK  
 Serial number : ./.  
 Ratings : AC Adapter Model: YLPS121250C1-US  
 Input: 100-240V ~ 50/60Hz 0.5A  
 Output: 12V = 1.25A  
 PoE: 54 Vd.c., 0.56A

Test voltage : DC 12V  
 FCC ID : T2C-ROOMCAST  
 IC : 10741A-ROOMCAST  
 PMN : Wireless Presentation System  
 HVIN : RoomCast  
 Additional information : ./

### RadioTechnical data

Radio Tech. : WLAN (IEEE 802.11 a,n,ac) / U-NII-1&U-NII-3 MIMO  
 Frequency Range : 5 180 MHz ~ 5 240 MHz (U-NII-1 Band 1: 11a/n\_HT20, 11ac\_VHT20)  
 5 190 MHz ~ 5 230 MHz (U-NII-1 Band 1: 11n\_HT40, 11ac\_VHT40)  
 5 210 MHz (U-NII-1 Band 1: 11ac\_VHT80)  
 5 745 MHz ~ 5 825 MHz (U-NII-3 Band: 11a/n\_HT20, 11ac\_VHT20)  
 5 755 MHz ~ 5 795 MHz (U-NII-3 Band: 11n\_HT40, 11ac\_VHT40)  
 5 775 MHz (U-NII-3 Band: 11ac\_VHT80)  
 Modulation : 802.11a: OFDM (BPSK, QPSK, 16QAM, 64QAM)  
 802.11n: OFDM (BPSK, QPSK, 16QAM, 64QAM)  
 802.11ac: OFDM (BPSK, QPSK, 16QAM, 64QAM, 256QAM)  
 Antenna type : FPC antenna  
 Channel Spacing : 802.11a/n(HT20)/ac(VHT20): 20MHz  
 802.11n(HT40)/ac(VHT40): 40MHz  
 802.11ac(VHT80): 80MHz  
 Antenna gain : 5 150 MHz ~ 5 250 MHz: 3.0 dB i  
 5 725 MHz ~ 5 850 MHz: 3.0 dB i

## 1.7 Test standards

Test Standards	
FCC Part 15 Subpart C	PART 15 - RADIO FREQUENCY DEVICES Subpart C - Intentional Radiators
FCC Part 15 Subpart E	Subpart E—Unlicensed National Information Infrastructure Devices
RSS-247 Issue 2 February 2017	RSS-247 — Digital Transmission Systems (DTSs), Frequency Hopping Systems (FHSs) and Licence-Exempt Local Area Network (LE-LAN) Devices
RSS-GEN Issue 5 March 2019	RSS-Gen — General Requirements for Compliance of Radio Apparatus

### Test Method

- 1: ANSI C63.4-2014, American National Standard for Methods of Measurement of Radio-Noise Emissions from Low-Voltage Electrical and Electronic Equipment in the Range of 9 kHz to 40 GHz.
- 2: ANSI C63.10-2013, American National Standard for Testing Unlicensed Wireless Devices.
- 3: KDB789033 D02 General UNII Test Procedures New Rules v02r01

## 2 Technical test

### 2.1 Summary of test results

No deviations from the technical specification(s) were ascertained in the course of the tests performed.

or

The deviations as specified were ascertained in the course of the tests performed.

### 2.2 Test environment

Ac line conducted

Environment Parameter	Temperature	Relative Humidity
101.2kPa	23.7 °C	61.3%

RF conducted

Environment Parameter	Temperature	Relative Humidity
101.2kPa	24.7 °C	43.1%

Radiated

Environment Parameter	Temperature	Relative Humidity
101.2kPa	24.3 °C	51.6%

### 2.3 Measurement uncertainty

The uncertainty is calculated using the methods suggested in the "Guide to the Expression of Uncertainty in Measurement" (GUM) published by ISO.

System Measurement Uncertainty	
Test Items	Extended Uncertainty
Uncertainty in conducted measurements	1.96dB
Uncertainty for Conducted RF test	RF Power Conducted: 1.16dB Frequency test involved: 1.05x10 <sup>-7</sup> or 1%
Uncertainty for Radiated Spurious Emission 25MHz-3000MHz	Horizontal: 4.46dB; Vertical: 4.54dB;
Uncertainty for Radiated Spurious Emission 3000MHz-18000MHz	Horizontal: 4.42dB; Vertical: 4.41dB;
Uncertainty for Radiated Spurious Emission 18000MHz-40000MHz	Horizontal: 4.63dB; Vertical: 4.62dB;



## 2.4 Test mode

Frequency band (MHz)		5150~5250	
802.11a / n HT20 / ac VHT20		802.11n HT40 / ac VHT40	
Channel	Frequency(MHz)	Channel	Frequency(MHz)
36	5180	38	5190
40	5200	46	5230
44	5220	<b>802.11ac VHT80</b>	
48	5240	42	5210

Frequency band (MHz)		5725~5850	
802.11a / n HT20 / ac VHT20		802.11n HT40 / ac VHT40	
Channel	Frequency(MHz)	Channel	Frequency(MHz)
149	5745	151	5755
153	5765	159	5795
157	5785	<b>802.11ac VHT80</b>	
161	5805	155	5775
165	5825	--	--

For U-NII-1 Bnad 802.11a/n(HT20 SISO/MIMO)/ac(VHT20 SISO/MIMO), the lowest, middle, highest channel numbers of the EUT used and tested in this report are separately 36 (5180MHz), 40 (5200MHz) and 48 (5240MHz).

For U-NII-1 Bnad 802.11n(HT40 SISO/MIMO)/ac(VHT40 SISO/MIMO), the lowest, highest channel numbers of the EUT used and tested in this report are separately 38 (5190MHz) , 46 (5230MHz).

For U-NII-1 Bnad 802.11ac(VHT80 SISO/MIMO), the middle channel numbers of the EUT used and tested in this report are separately 42 (5210MHz).

For U-NII-3 Bnad 802.11a/n(HT20 SISO/MIMO)/ac(VHT20 SISO/MIMO), the lowest, middle, highest channel numbers of the EUT used and tested in this report are separately 149 (5745MHz), 157 (5785MHz) and 165 (5825MHz).

For U-NII-3 Bnad 802.11n(HT40 SISO/MIMO)/ac(VHT40 SISO/MIMO), the lowest, highest channel numbers of the EUT used and tested in this report are separately 151 (5755MHz) , 159 (5795MHz).

For U-NII-3 Bnad 802.11ac(VHT80 SISO/MIMO), the middle channel numbers of the EUT used and tested in this report are separately 155 (5775MHz).

The EUT was set at continuously transmitting mode during the test.

## 2.5 Test equipment utilized

EQUIPMENT ID	EQUIPMENT NAME	MODEL NO.	CAL. DUE DATE
23-2-13-05	EMI Test Receiver	ESR3	2022-03-15
23-2-13-06	LISN	NNLK 8127 RC	2022-03-15
23-2-10-16	Attenuator	VTSD 9561-F	2022-03-16
23-2-10-63	Temperature & Humidity Meter	COS-03	2022-03-27
23-2-10-65	Barometer	Baro	2022-03-23
23-2-13-12	Signal Analyzer	N9010B-544	2022-03-15
23-2-13-13	BT/WLAN Tester	CMW270	2022-03-15
23-2-13-14	Signal Generator	N5183B-520	2022-03-15
23-2-13-15	Vector Signal Generator	N5182B-506	2022-03-15
23-2-10-43	Switch and Control Unit	ERIT-E-JS0806-2	2022-06-17
23-2-10-44	DC power supply	E3642A	2022-06-03
23-2-10-45	Temperature test chamber	SG-80-CC-2	2022-03-15
23-2-10-50	Temperature & Humidity Meter	COS-03	2022-03-27
23-2-10-66	Barometer	Baro	2022-03-23
23-2-13-01	EMI Test Receiver	ESR7	2022-03-15
23-2-13-02	Signal Analyzer	N9020B-544	2022-03-15
23-2-12-01	Active Loop Antenna	FMZB 1519B	2022-05-13
23-2-12-02	TRILOG Broadband Antenna	VULB9168	2022-04-27
23-2-12-03	Horn Antenna	3117	2022-05-11
23-2-12-04	Horn Antenna	BBHA 9170	2022-05-11
23-2-10-01	Preamplifier	BBV9745	2022-03-16
23-2-10-02	Preamplifier	TAP01018048	2022-03-16
23-2-10-03	Preamplifier	TAP18040048	2022-03-22
23-2-10-62	Temperature & Humidity Meter	COS-03	2022-03-27
23-2-10-64	Barometer	Baro	2022-03-23
23-2-10-14	Switch and Control Unit	ERIT-E-JS0806-SF1	N/A
23-2-13-03	EMI Test Receiver	ESR7	2022-03-16
23-2-13-04	Signal Analyzer	N9020B-526	2022-03-15
23-2-12-06	Active Loop Antenna	FMZB 1519B	2022-05-13
23-2-12-07	TRILOG Broadband Antenna	VULB9168	2022-04-27
23-2-12-08	Horn Antenna	3117	2022-05-11
23-2-10-46	Preamplifier	BBV9745	2022-03-16
23-2-10-47	Preamplifier	TAP01018048	2022-03-16
23-2-10-61	Temperature & Humidity Meter	COS-03	2022-03-27
23-2-10-52	Barometer	Baro	2022-03-23
23-2-10-15	Switch and Control Unit	ERIT-E-JS0806-SF1	N/A

## 2.6 Auxiliary equipment used during test

DESCRIPTION	MANUFACTURER	MODEL NO.	S/N
Laptop	LENOVO	TP00096A	PF-1QH0LV

## 2.7 Test software information

Test Software&Version	QCARCT / V3.0250.0		
Mode	Power setting		Rate
	Ant1	Ant2	
802.11a	8	8	6Mbit
802.11n HT20	7.5	7.5	MCS0
802.11n HT40	7.5	7.5	MCS0
802.11ac VHT20	7.5	7.5	AC_MCS0
802.11ac VHT40	7.5	7.5	AC_MCS0
802.11ac HT80	7	7	AC_MCS0

## 2.8 Test setup

Ac line conducted

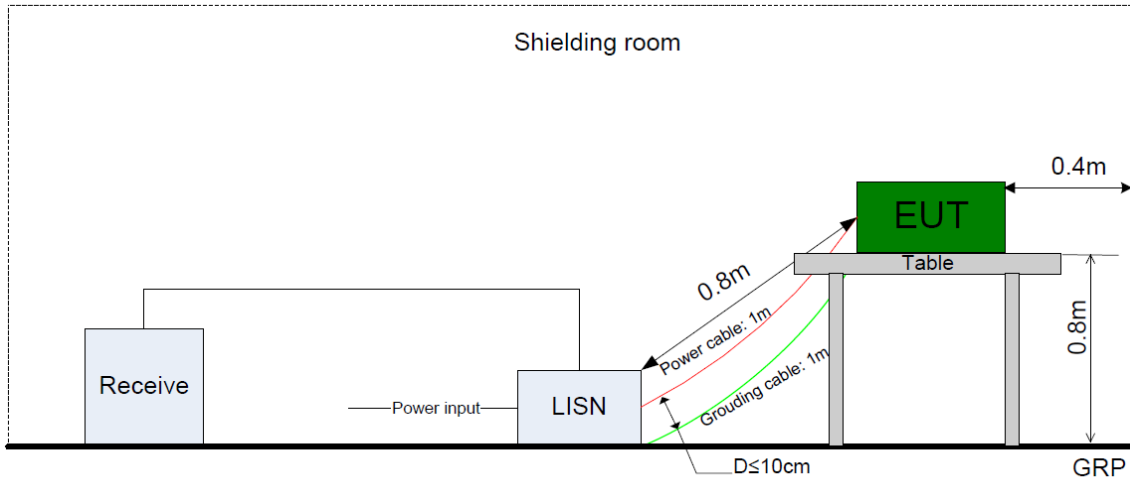

RF Conducted tests

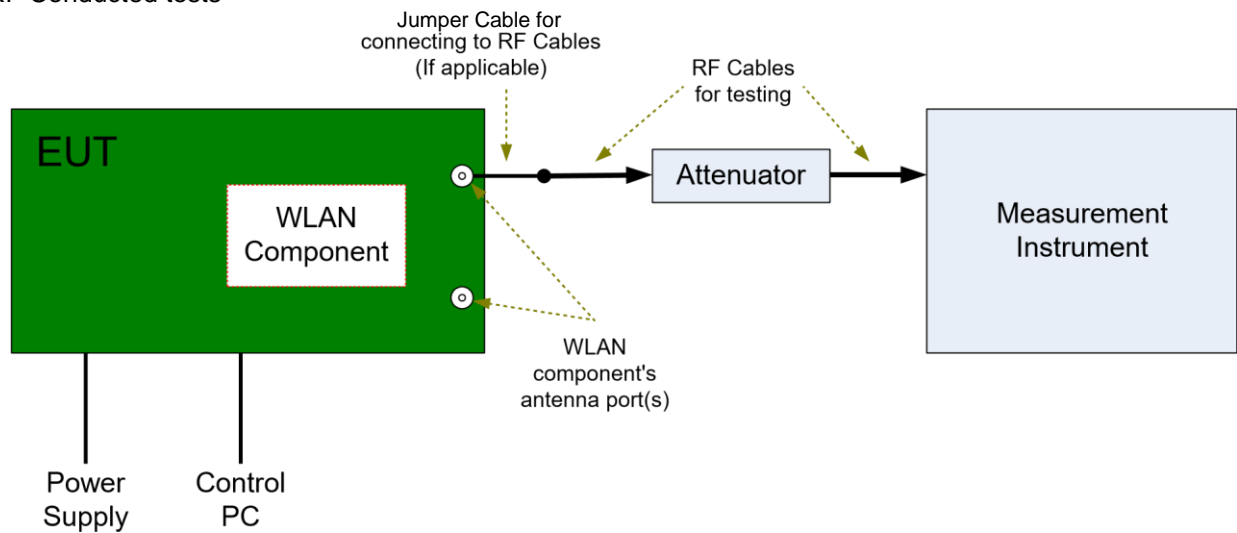

Radiated tests below 30MHz

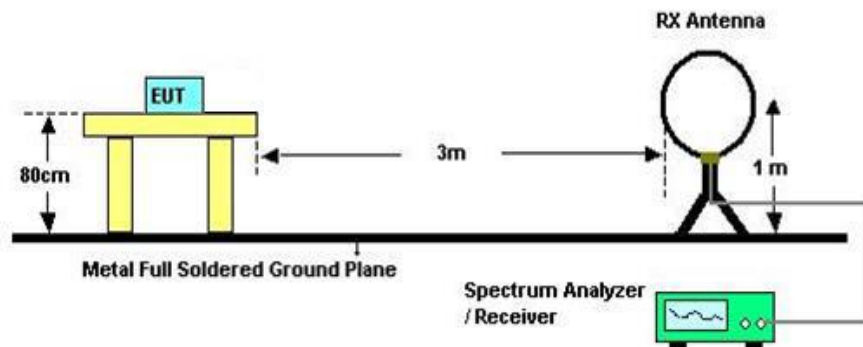

## Radiated tests below 1GHz

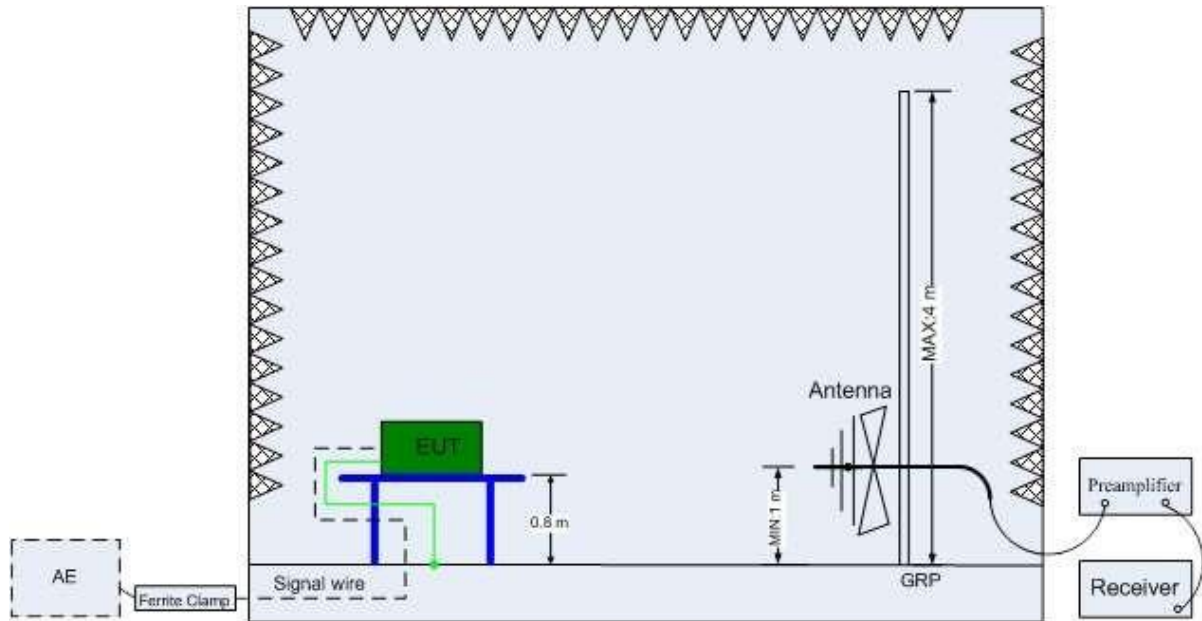

## Radiated tests above 1GHz

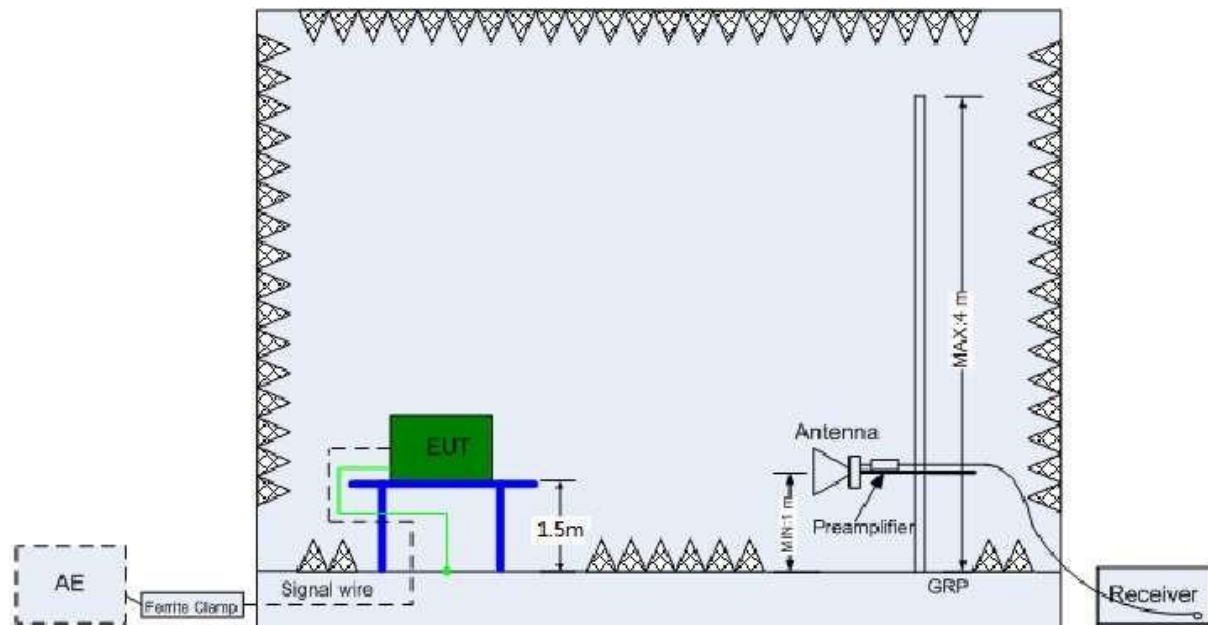

## 2.9 Test results

 1<sup>st</sup> test

 test after modification

 production test

Technical Requirements					
FCC Part 15 Subpart E/ IC RSS-247 Issue 2 / RSS-Gen Issue 5					
Test Condition			Test Result	Verdict	Test Site
§15.207	RSS-GEN 8.8	Conducted emission AC power port	Appendix E	Pass	Site 1
§15.407(a)(1) §15.407(a)(3)	RSS-247 Issue 2 6.2.1.1 RSS-247 Issue 2 6.2.4.1	Maximum Conducted Output Power	Appendix B	Pass	Site 1
§15.407(a)(1) §15.407(a)(3)	RSS-247 Issue 2 6.2.1.1 RSS-247 Issue 2 6.2.4.1	Power spectral density	Appendix C	Pass	Site 1
§15.407(e)	RSS-247 Issue 2 6.2.4.1	6 dB bandwidth	Appendix A3	Pass	Site 1
§15.407(a)	--	26 dB Bandwidth	Appendix A1	N/A	--
--	RSS-GEN 6.7	99% Occupied Bandwidth	Appendix A2	Pass	Site 1
§15.205(a) §15.209(a) §15.407(b)(1) §15.407(b)(4)	RSS-Gen Issue 5 8.9 RSS-Gen Issue 5 8.10 RSS-247 Issue 2 6.2.1.2 RSS-247 Issue 2 6.2.4.2	Transmitter Radiated Spurious Emissions	Appendix F	Pass	Site 1
--	--	Duty cycle	Appendix D	Pass	Pass
§15.203	RSS-GEN 6.8	Antenna requirement	See note 1	Pass	--

Remark 1: N/A – Not Applicable.

Note 1: The EUT uses a FPC antenna, the antenna 1 gain: 3.0 dBi, the antenna 2 gain: 3.0 dBi. According to §15.203/ RSS-GEN 6.8, it is considered sufficiently to comply with the provisions of this section.

### 3 Technical Requirement

#### 3.1 Conducted emission AC power port

**Test Method:**

The test method was referred to the subclause 6.2 of ANSI C63.10-2013.

The EUT is placed on a non-conducting table 40 cm from the vertical ground plane and 80 cm above the horizontal ground plane. The EUT is configured in accordance with ANSI C63.10.

The receiver is set to a resolution bandwidth of 9 kHz. Peak detection is used unless otherwise noted as quasi-peak or average.

Line conducted data is recorded for both Neutral and Live lines.

**Limit:**

FCC §15.207 (a)

RSS-Gen 8.8

<b>Frequency</b>	<b>QP Limit</b>	<b>AV Limit</b>
<b>MHz</b>	<b>dB<math>\mu</math>V</b>	<b>dB<math>\mu</math>V</b>
0.150-0.500	66-56*	56-46*
0.500-5	56	46
5-30	60	50

Decreasing linear.

## 3.2 Duty cycle

### Test Method:

The test method was referred to the subclause 11.6 of ANSI C63.10-2013.

Measurements of duty cycle and transmission duration shall be performed using one of the following techniques:

- a) A diode detector and an oscilloscope that together have a sufficiently short response time to permit accurate measurements of the ON and OFF times of the transmitted signal.
- b) The zero-span mode on a spectrum analyzer or EMI receiver if the response time and spacing between bins on the sweep are sufficient to permit accurate measurements of the ON and OFF times of the transmitted signal:
  - 1) Set the center frequency of the instrument to the center frequency of the transmission.
  - 2) Set  $RBW \cong OBW$  if possible; otherwise, set RBW to the largest available value.
  - 3) Set  $VBW \cong RBW$ . Set detector = peak or average.
  - 4) The zero-span measurement method shall not be used unless both RBW and VBW are  $> 50/T$  and the number of sweep points across duration  $T$  exceeds 100. (For example, if VBW and/or RBW are limited to 3 MHz, then the zero-span method of measuring the duty cycle shall not be used if  $T \leq 16.7 \mu s$ .)

### Limit:

None; for reporting purposes only.



### 3.3 6dB bandwidth

**Test Method:**

The test method was referred to the subclause 11.8 of ANSI C63.10-2013.

The steps for the first option are as follows:

- a) Set RBW = 100 kHz.
- b) Set the VBW  $\cong$  [3 × RBW].
- c) Detector = peak.
- d) Trace mode = max hold.
- e) Sweep = auto couple.
- f) Allow the trace to stabilize.
- g) Measure the maximum width of the emission that is constrained by the frequencies associated with the two outermost amplitude points (upper and lower frequencies) that are attenuated by 6 dB relative to the maximum level measured in the fundamental emission.

**Limit:**

FCC §15.407 (e)

RSS-247 Issue 2  
6.2.4.1

The minimum 6 dB bandwidth shall be at least 500 kHz.

### 3.4 99% Occupied Bandwidth

**Test Method:**

The test method was referred to the subclause D of KDB 789033 D02 General UNII Test Procedures New Rules v02r01.

The following procedure shall be used for measuring (99%) power bandwidth:

1. Set center frequency to the nominal EUT channel center frequency.
2. Set span = 1.5 times to 5.0 times the OBW.
3. Set RBW = 1% to 5% of the OBW
4. Set VBW  $\geq 3 \times$  RBW
5. Video averaging is not permitted. Where practical, a sample detection and single sweep mode shall be used. Otherwise, peak detection and max hold mode (until the trace stabilizes) shall be used.
6. Use the 99% power bandwidth function of the instrument (if available).
7. If the instrument does not have a 99% power bandwidth function, the trace data points are recovered and directly summed in power units. The recovered amplitude data points, beginning at the lowest frequency, are placed in a running sum until 0.5% of the total is reached; that frequency is recorded as the lower frequency. The process is repeated until 99.5% of the total is reached; that frequency is recorded as the upper frequency. The 99% occupied bandwidth is the difference between these two frequencies.

**Limit:**

None; for reporting purposes only.

### 3.5 26 dB Bandwidth

**Test Method:**

The test method was referred to the subclause C.1 of KDB 789033 D02 General UNII Test Procedures New Rules v02r01.

- a) Set RBW = approximately 1% of the emission bandwidth.
- b) Set the VBW > RBW.
- c) Detector = Peak.
- d) Trace mode = max hold.
- e) Measure the maximum width of the emission that is 26 dB down from the maximum of the emission. Compare this with the RBW setting of the analyzer. Readjust RBW and repeat measurement as needed until the RBW/EBW ratio is approximately 1%.

**Limit:**

None; for reporting purposes only.

### 3.6 Maximum Conducted Output Power

#### Test Method

The test method was referred to the subclause E.2 of KDB 789033 D02 General UNII Test Procedures New Rules v02r01.

Measurement of maximum conducted output power using a spectrum analyzer requires integrating the spectrum across a frequency span that encompasses, at a minimum, either the EBW or the 99% occupied bandwidth of the signal. However, the EBW must be used to determine bandwidth dependent limits on maximum conducted output power in accordance with Section 15.407(a).

- a) The test method shall be selected as follows:
  - (i) Method SA-1 or SA-1 Alternative (averaging with the EUT transmitting at full power throughout each sweep) shall be applied if either of the following conditions can be satisfied:
    - The EUT transmits continuously (or with a duty cycle  $\geq 98\%$ ).
    - Sweep triggering or gating can be implemented in a way that the device transmits at the maximum power control level throughout the duration of each of the instrument sweeps to be averaged. This condition can generally be achieved by triggering the instrument's sweep if the duration of the sweep (with the analyzer configured as in Method SA-1, i.e., II.E.2.b)) is equal to or shorter than the duration  $T$  of each transmission from the EUT and if those transmissions exhibit full power throughout their durations.
  - (ii) Method SA-2 or SA-2 Alternative (averaging across on and off times of the EUT transmissions, followed by duty cycle correction) shall be applied if the conditions of (i) cannot be achieved and the transmissions exhibit a constant duty cycle during the measurement duration. Duty cycle will be considered to be constant if variations are less than  $\pm 2\%$ .
  - (iii) Method SA-3 (power averaging (rms) detection with max hold) or SA-3 Alternative (reduced VBW with max hold) shall be applied if the conditions of (i) and (ii) cannot be achieved.
- b) **Method SA-1** (trace averaging with the EUT transmitting at full power throughout each sweep):
  - (i) Set span to encompass the entire emission bandwidth (EBW) (or, alternatively, the entire 99% occupied bandwidth) of the signal.
  - (ii) Set RBW = 1 MHz.
  - (iii) Set VBW  $\geq 3$  MHz.
  - (iv) Number of points in sweep  $\geq 2 \times \text{span} / \text{RBW}$ . (This ensures that bin-to-bin spacing is  $\leq \text{RBW}/2$ , so that narrowband signals are not lost between frequency bins.)
  - (v) Sweep time = auto.
  - (vi) Detector = power averaging (rms), if available. Otherwise, use sample detector mode.
  - (vii) If transmit duty cycle  $< 98\%$ , use a video trigger with the trigger level set to enable triggering only on full power pulses. Transmitter must operate at maximum power control level for the entire duration of every sweep. If the EUT transmits continuously (i.e., with no off intervals) or at duty cycle  $\geq 98\%$ , and if each transmission is entirely at the maximum power control level, then the trigger shall be set to "free run."

- (viii) Trace average at least 100 traces in power averaging (rms) mode.
  - (ix) Compute power by integrating the spectrum across the EBW (or, alternatively, the entire 99% occupied bandwidth) of the signal using the instrument's band power measurement function with band limits set equal to the EBW (or occupied bandwidth) band edges. If the instrument does not have a band power function, sum the spectrum levels (in power units) at 1 MHz intervals extending across the EBW (or, alternatively, the entire 99% occupied bandwidth) of the spectrum.
- c) **Method SA-1 Alternative** (power averaging (rms) detection with slow sweep and EUT transmitting continuously at full power):
- (i) Set span to encompass the entire EBW (or, alternatively, the entire 99% occupied bandwidth) of the signal.
  - (ii) Set RBW = 1 MHz.
  - (iii) Set VBW  $\geq$  3 MHz.
  - (iv) Number of points in sweep  $\geq 2 \times \text{span} / \text{RBW}$ . (This ensures that bin-to-bin spacing is  $\leq \text{RBW}/2$ , so that narrowband signals are not lost between frequency bins.)
  - (v) Manually set sweep time  $\geq 10 \times (\text{number of points in sweep}) \times (\text{symbol period of the transmitted signal})$ , but not less than the automatic default sweep time.
  - (vi) Set detector = power averaging (rms).
  - (vii) The EUT shall be operated at 100% duty cycle.
  - (viii) Perform a single sweep.
  - (ix) Compute power by integrating the spectrum across the EBW (or, alternatively, the entire 99% occupied bandwidth) of the signal using the instrument's band power measurement function with band limits set equal to the EBW (or occupied bandwidth) band edges. If the instrument does not have a band power function, sum the spectrum levels (in power units) at 1 MHz intervals extending across the EBW (or, alternatively, the entire 99% occupied bandwidth) of the spectrum.
- d) **Method SA-2** (trace averaging across on and off times of the EUT transmissions, followed by duty cycle correction).
- (i) Measure the duty cycle,  $x$ , of the transmitter output signal as described in II.B.
  - (ii) Set span to encompass the EBW (or, alternatively, the entire 99% occupied bandwidth) of the signal.
  - (iii) Set RBW = 1 MHz.
  - (iv) Set VBW  $\geq$  3 MHz.
  - (v) Number of points in sweep  $\geq 2 \times \text{span} / \text{RBW}$ . (This ensures that bin-to-bin spacing is  $\leq \text{RBW}/2$ , so that narrowband signals are not lost between frequency bins.)
- (vi) Sweep time = auto.
- (vii) Detector = power averaging (rms), if available. Otherwise, use sample detector mode.
  - (viii) Do not use sweep triggering. Allow the sweep to "free run."

- (ix) Trace average at least 100 traces in power averaging (rms) mode; however, the number of traces to be averaged shall be increased above 100 as needed to ensure that the average accurately represents the true average over the on and off periods of the transmitter.
  - (x) Compute power by integrating the spectrum across the EBW (or, alternatively, the entire 99% occupied bandwidth) of the signal using the instrument's band power measurement function with band limits set equal to the EBW (or occupied bandwidth) band edges. If the instrument does not have a band power function, sum the spectrum levels (in power units) at 1 MHz intervals extending across the EBW (or, alternatively, the entire 99% occupied bandwidth) of the signal.
  - (xi) Add  $10 \log(1/x)$ , where  $x$  is the duty cycle, to the measured power in order to compute the average power during the actual transmission times (because the measurement represents an average over both the on and off times of the transmission). For example, add  $10 \log(1/0.25) = 6$  dB if the duty cycle is 25%.
- e) **Method SA-2 Alternative** (power averaging (rms) detection with slow sweep with each spectrum bin averaging across on and off times of the EUT transmissions, followed by duty cycle correction).
- (i) Measure the duty cycle,  $x$ , of the transmitter output signal as described in II.B.
  - (ii) Set span to encompass the entire EBW (or, alternatively, the entire 99% occupied bandwidth) of the signal.
  - (iii) Set RBW = 1 MHz.
  - (iv) Set VBW  $\geq$  3 MHz.
  - (v) Number of points in sweep  $\geq 2 \times \text{span} / \text{RBW}$ . (This ensures that bin-to-bin spacing is  $\leq \text{RBW}/2$ , so that narrowband signals are not lost between frequency bins.)
  - (vi) Manually set sweep time  $\geq 10 \times (\text{number of points in sweep}) \times (\text{total on/off period of the transmitted signal})$ .
  - (vii) Set detector = power averaging (rms).
  - (viii) Perform a single sweep.
  - (ix) Compute power by integrating the spectrum across the EBW (or, alternatively, the entire 99% occupied bandwidth) of the signal using the instrument's band power measurement function with band limits set equal to the EBW (or occupied bandwidth) band edges. If the instrument does not have a band power function, sum the spectrum levels (in power units) at 1 MHz intervals extending across the EBW (or, alternatively, the entire 99% occupied bandwidth) of the spectrum.
  - (x) Add  $10 \log(1/x)$ , where  $x$  is the duty cycle, to the measured power in order to compute the average power during the actual transmission times (because the measurement represents an average over both the on and off times of the transmission). For example, add  $10 \log(1/0.25) = 6$  dB if the duty cycle is 25%.
- f) **Method SA-3** (power averaging (rms) detection with max hold):
- (i) Set span to encompass the entire EBW (or, alternatively, the entire 99% occupied bandwidth) of the signal. (ii) Set sweep trigger to "free run." (iii) Set RBW = 1 MHz.
  - (iv) Set VBW  $\geq$  3 MHz

- (v) Number of points in sweep  $\geq 2 \times \text{span} / \text{RBW}$ . (This ensures that bin-to-bin spacing is  $\leq \text{RBW}/2$ , so that narrowband signals are not lost between frequency bins.)
- (vi) Sweep time  $\leq (\text{number of points in sweep}) \times T$ , where  $T$  is defined in II.B.1.a).

Note: If this results in a sweep time less than the auto sweep time of the analyzer, Method SA-3 Alternative shall not be used. (The purpose of this step is to ensure that averaging time in each bin is less than or equal to the minimum time of a transmission.) (vii) Detector = power averaging (rms).

(viii) Trace mode = max hold.

(ix) Allow max hold to run for at least 60 seconds, or longer as needed to allow the trace to stabilize.

(x) Compute power by integrating the spectrum across the EBW (or, alternatively, the entire 99% occupied bandwidth) of the signal using the instrument's band power measurement function with band limits set equal to the EBW (or occupied bandwidth) band edges. If the instrument does not have a band power function, sum the spectrum levels (in power units) at 1 MHz intervals extending across the EBW (or, alternatively, the entire 99% occupied bandwidth) of the spectrum.

g) **Method SA-3 Alternative** (Reduced VBW with max hold):

(i) Set span to encompass the entire emission bandwidth (EBW) of the signal.

(ii) Set sweep trigger to "free run." (iii) Set RBW = 1 MHz.

(iv) Set VBW  $\geq 1/T$ , where  $T$  is defined in II.B.1.a).

(v) Number of points in sweep  $\geq 2 \times \text{span} / \text{RBW}$ . (This ensures that bin-to-bin spacing is  $\leq \text{RBW}/2$ , so that narrowband signals are not lost between frequency bins.)

(vi) Sweep time = auto.

(vii) Detector = peak.

(viii) Video filtering shall be applied to a voltage-squared or power signal (rms), if possible. Otherwise, it shall be set to operate on a linear voltage signal (which may require use of linear display mode). Log mode must not be used.

- The preferred voltage-squared (i.e., power or rms) mode is selected on some analyzers by setting the "Average-VBW Type" to power or rms.

- If power averaging (rms) mode is not available, linear voltage mode is selected on some analyzers by setting the display mode to linear. Other analyzers have a setting for "Average-VBW Type" that can be set to "Voltage" regardless of the display mode. (ix) Trace mode = max hold.

(x) Allow max hold to run for at least 60 seconds, or longer as needed to allow the trace to stabilize.

(xi) Compute power by integrating the spectrum across the EBW (or, alternatively, the entire 99% occupied bandwidth) of the signal using the instrument's band power measurement function with band limits set equal to the EBW (or occupied bandwidth) band edges. If the instrument does not have a band power function, sum the spectrum levels

(in power units) at 1 MHz intervals extending across the EBW (or, alternatively, the entire 99% occupied bandwidth) of the spectrum.

(xii) If linear mode was used in II.E.2.g)(viii), add 1 dB to the final result to compensate for the difference between linear averaging and power averaging.

#### Limits:

##### FCC 15.407(a)(1)(iv)

For client devices in the 5.15-5.25 GHz band, the maximum conducted output power over the frequency band of operation shall not exceed 250 mW provided the maximum antenna gain does not exceed 6 dBi. In addition, the maximum power spectral density shall not exceed 11 dBm in any 1 megahertz band. If transmitting antennas of directional gain greater than 6 dBi are used, both the maximum conducted output power and the maximum power spectral density shall be reduced by the amount in dB that the directional gain of the antenna exceeds 6 dBi.

##### FCC 15.407(a)(3)

For the band 5.725-5.85 GHz, the maximum conducted output power over the frequency band of operation shall not exceed 1 W. In addition, the maximum power spectral density shall not exceed 30 dBm in any 500-kHz band. If transmitting antennas of directional gain greater than 6 dBi are used, both the maximum conducted output power and the maximum power spectral density shall be reduced by the amount in dB that the directional gain of the antenna exceeds 6 dBi. However, fixed point-to-point U-NII devices operating in this band may employ transmitting antennas with directional gain greater than 6 dBi without any corresponding reduction in transmitter conducted power. Fixed, point-to-point operations exclude the use of point-to-multipoint systems, omnidirectional applications, and multiple collocated transmitters transmitting the same information. The operator of the U-NII device, or if the equipment is professionally installed, the installer, is responsible for ensuring that systems employing high gain directional antennas are used exclusively for fixed, point-to-point operations.

##### RSS-247 Issue 2,

###### 6.2.1.1 Frequency band 5 150-5 250 MHz

For OEM devices installed in vehicles, the maximum e.i.r.p. shall not exceed 30 mW or  $1.76 + 10 \log_{10} B$ , dBm, whichever is less. Devices shall implement transmitter power control (TPC) in order to have the capability to operate at least 3 dB below the maximum permitted e.i.r.p. of 30 mW.

For other devices, the maximum e.i.r.p. shall not exceed 200 mW or  $10 + 10 \log_{10} B$ , dBm, whichever power is less. B is the 99% emission bandwidth in megahertz. The e.i.r.p. spectral density shall not exceed 10 dBm in any 1.0 MHz band.

###### 6.2.4.1 Frequency band 5 725-5 850 MHz

For equipment operating in the band 5725-5850 MHz, the minimum 6 dB bandwidth shall be at least 500 kHz.

The maximum conducted output power shall not exceed 1 W. The output power spectral density shall not exceed 30 dBm in any 500 kHz band. If transmitting antennas of directional gain greater than 6 dBi are used, both the maximum conducted output power and the output power spectral density shall be reduced by the amount in dB that the directional gain of the antenna exceeds 6 dBi. However, fixed point-to-point devices operating in this band may employ transmitting antennas with directional gain greater than 6 dBi without any corresponding reduction in transmitter conducted power. Fixed point-to-point operations exclude the use of point-to-multipoint systems, omnidirectional applications and multiple collocated transmitters transmitting the same information.



### 3.7 Power spectral density

#### Test Method:

The test method was referred to the subclause F.5 of KDB 789033 D02 General UNII Test Procedures New Rules v02r01.

For devices operating in the bands 5.15–5.25 GHz, 5.25–5.35 GHz, and 5.47–5.725 GHz, the preceding procedures make use of 1 MHz RBW to satisfy directly the 1 MHz reference bandwidth specified in Section 15.407(a)(5). For devices operating in the band 5.725–5.85 GHz, the rules specify a measurement bandwidth of 500 kHz. Many spectrum analyzers do not have 500 kHz RBW, thus a narrower RBW may need to be used. The rules permit the use of RBWs less than 1 MHz, or 500 kHz, “provided that the measured power is integrated over the full reference bandwidth” to show the total power over the specified measurement bandwidth (i.e., 1 MHz, or 500 kHz). If measurements are performed using a reduced resolution bandwidth (< 1 MHz, or < 500 kHz) and integrated over 1 MHz, or 500 kHz bandwidth, the following adjustments to the procedures apply:

- a) Set  $RBW \geq 1/T$ , where  $T$  is defined in II.B.I.a).
- b) Set  $VBW \geq 3 RBW$ .
- c) If measurement bandwidth of Maximum PSD is specified in 500 kHz, add  $10 \log(500 \text{ kHz}/RBW)$  to the measured result, whereas RBW (<500 kHz) is the reduced resolution bandwidth of the spectrum analyzer set during measurement.
- d) If measurement bandwidth of Maximum PSD is specified in 1 MHz, add  $10 \log(1\text{MHz}/RBW)$  to the measured result, whereas RBW (< 1 MHz) is the reduced resolution bandwidth of spectrum analyzer set during measurement.
- e) Care must be taken to ensure that the measurements are performed during a period of continuous transmission or are corrected upward for duty cycle.

#### Limit:

##### FCC 15.407(a)(1)(iv)

For client devices in the 5.15-5.25 GHz band, the maximum conducted output power over the frequency band of operation shall not exceed 250 mW provided the maximum antenna gain does not exceed 6 dBi. In addition, the maximum power spectral density shall not exceed 11 dBm in any 1 megahertz band. If transmitting antennas of directional gain greater than 6 dBi are used, both the maximum conducted output power and the maximum power spectral density shall be reduced by the amount in dB that the directional gain of the antenna exceeds 6 dBi.

##### FCC 15.407(a)(3)

For the band 5.725-5.85 GHz, the maximum conducted output power over the frequency band of operation shall not exceed 1 W. In addition, the maximum power spectral density shall not exceed 30 dBm in any 500-kHz band. If transmitting antennas of directional gain greater than 6 dBi are used, both the maximum conducted output power and the maximum power spectral density shall be reduced by the amount in dB that the directional gain of the antenna exceeds 6 dBi. However, fixed point-to-point U-NII devices operating in this band may employ transmitting antennas with directional gain greater than 6 dBi without any corresponding reduction in transmitter conducted power. Fixed, point-to-point operations exclude the use of point-to-multipoint systems, omnidirectional applications, and multiple collocated transmitters transmitting the same information. The operator of the U-NII device, or if the equipment is professionally installed, the installer, is responsible for ensuring that systems employing high gain directional antennas are used exclusively for fixed, point-to-point operations.

RSS-247 Issue 2,

6.2.1.1 Frequency band 5 150-5 250 MHz

For OEM devices installed in vehicles, the maximum e.i.r.p. shall not exceed 30 mW or  $1.76 + 10 \log_{10} B$ , dBm, whichever is less. Devices shall implement transmitter power control (TPC) in order to have the capability to operate at least 3 dB below the maximum permitted e.i.r.p. of 30 mW.

For other devices, the maximum e.i.r.p. shall not exceed 200 mW or  $10 + 10 \log_{10} B$ , dBm, whichever power is less. B is the 99% emission bandwidth in megahertz. The e.i.r.p. spectral density shall not exceed 10 dBm in any 1.0 MHz band.

#### 6.2.4.1 Frequency band 5 725-5 850 MHz

For equipment operating in the band 5725-5850 MHz, the minimum 6 dB bandwidth shall be at least 500 kHz.

The maximum conducted output power shall not exceed 1 W. The output power spectral density shall not exceed 30 dBm in any 500 kHz band. If transmitting antennas of directional gain greater than 6 dBi are used, both the maximum conducted output power and the output power spectral density shall be reduced by the amount in dB that the directional gain of the antenna exceeds 6 dBi. However, fixed point-to-point devices operating in this band may employ transmitting antennas with directional gain greater than 6 dBi without any corresponding reduction in transmitter conducted power. Fixed point-to-point operations exclude the use of point-to-multipoint<sup>Footnote3</sup> systems, omnidirectional applications and multiple collocated transmitters transmitting the same information.

### 3.8 Transmitter radiated spurious emissions

#### Test Method:

The test method was referred to the subclause G of KDB 789033 D02 General UNII Test Procedures New Rules v02r01 and ANSI C63.10-2013.

#### Test Procedures for emission below 30 MHz

The EUT was placed on the top of a rotating table 0.8 meters above the ground at a 3 meter anechoic chamber test site. The table was rotated 360 degrees to determine the position of the highest radiation.

1. Then antenna is a loop antenna is fixed at one meter above the ground to determine the maximum value of the field strength. Both parallel and perpendicular of the antenna are set to make the measurement.
2. For each suspected emission, the EUT was arranged to its worst case and then the table was turned from 0 degrees to 360 degrees to find the maximum reading.
3. The test-receiver system was set to average or quasi peak detect function and Specified Bandwidth with Maximum Hold Mode.

#### Test Procedures for emission from above 30 MHz

The EUT was placed on the top of a rotating table 0.8 meters above the ground at a 3 meter anechoic chamber test site below 1 GHz and 1.5 meter above the ground at a 3 meter anechoic chamber test site above 1 GHz. The table was rotated 360 degrees to determine the position of the highest radiation.

1. During performing radiated emission below 1 GHz, the EUT was set 3 meters away from the interference receiving antenna, which was mounted on the top of a variable-height antenna tower. During performing radiated emission above 1 GHz, the EUT was set 3 meter away from the interference-receiving antenna.
2. The antenna is a bi-log antenna, a horn antenna and its height is varied from one meter to four meters above the ground to determine the maximum value of the field strength. Both horizontal and vertical polarizations of the antenna are set to make the measurement.
3. For each suspected emission, the EUT was arranged to its worst case and then the antenna was tuned to heights from 1 meter to 4 meters and the table was turned from 0 degrees to 360 degrees to find the maximum reading.
4. The test-receiver system was set to Peak Detect Function and Specified Bandwidth with Maximum Hold Mode.

#### Note

All data rates and modes were investigated for radiated spurious emissions. Only the radiated emissions of the configuration that produced the worst case emissions are reported in this section.

#### - II.G.4. Unwanted emissions measurements below 1 GHz

Compliance shall be demonstrated using CISPR quasi-peak detection; however, peak detection is permitted as an alternative to quasi-peak detection.

#### - II.G.5. Unwanted maximum emissions measurements above 1 GHz

Peak emission levels are measured by setting the analyzer as follows: Set to RBW = 1 MHz, VBW ≥ 3 MHz, Detector = Peak, Sweep time = auto, Trace mode = Max hold.

#### - II.G.6. Average unwanted emissions measurements above 1 GHz

Set to RBW = 1 MHz VBW ≥ 3 MHz Detector = power averaging (rms), Averaging type = power averaging (rms), Sweep time = auto, Perform a trace average of at least 100 traces If the transmission is continuous, If the transmission is not continuous, the number of traces shall be increased by a factor of 1/x, where x is the duty cycle. For example, with 50 % duty cycle, at least 200 traces shall be averaged.

If tests are performed with the EUT transmitting at a duty cycle less than 98 %, a correction factor shall be added to the measurement results prior to comparing to the emission limit in order to compute the emission level that would have been measured had the test been performed at 100 % duty cycle. The correction factor is computed as follows:

- If power averaging (rms) mode was used in II.G.6.c)(iv), the correction factor is  $10 \log (1 / x)$ , where x is the duty cycle. For example, if the transmit duty cycle was 50 %, then 3 dB must be added to the measured emission levels.

#### Limit:

##### FCC § 15.407(b)

(1) For transmitters operating in the 5.15-5.25 GHz band: All emissions outside of the 5.15-5.35 GHz band shall not exceed an e.i.r.p. of - 27 dB m/MHz.

(4) For transmitters operating in the 5.725-5.85 GHz band:

(i) All emissions shall be limited to a level of -27 dB m/MHz at 75 MHz or more above or below the band edge increasing linearly to 10 dB m/MHz at 25 MHz above or below the band edge, and from 25 MHz above or below the band edge increasing linearly to a level of 15.6 dB m/MHz at 5 MHz above or below the band edge, and from

5 MHz above or below the band edge increasing linearly to a level of 27 dB m/MHz at the band edge.

##### RSS-247 Issue 2

###### 6.2.1.2 Frequency band 5 150-5 250 MHz

For transmitters with operating frequencies in the band 5 150-5 250 MHz, all emissions outside the band 5 150-5 350 MHz shall not exceed -27 dB m/MHz e.i.r.p. Any unwanted emissions that fall into the band 5 250-5 350 MHz shall be attenuated below the channel power by at least 26 dB, when measured using a resolution bandwidth between 1 and 5 % of the occupied bandwidth (i.e. 99% bandwidth), above 5 250 MHz. The 26 dB bandwidth may fall into the 5 250-5 350 MHz band; however, if the occupied bandwidth also falls within the 5 250- 5350 MHz band, the transmission is considered as intentional and the devices shall comply with all requirements in the band 5 250-5 350 MHz including implementing dynamic frequency selection (DFS) and TPC, on the portion of the emission that resides in the 5 250-5 350 MHz band.

###### 6.2.4.2 Frequency band 5 725-5 850 MHz

Devices operating in the band 5 725-5 850 MHz with antenna gain greater than 10 dB i can have unwanted emissions that comply with either the limits in this section or in section 5.5 until six (6) months after the publication date of this standard for certification. Certified devices that do not comply with emission limits in this section shall not be manufactured, imported, distributed, leased, offered for sale or sold after April 1, 2018.

Devices operating in the band 5 725-5 850 MHz with antenna gain of 10 dB i or less can have unwanted emissions that comply with either the limits in this section or in section 5.5 until April 1, 2018 for certification. Certified devices that do not comply with emission limits in this section shall not be manufactured, imported, distributed, leased, offered for sale or sold after April 1, 2020.

Devices operating in the band 5 725-5 850 MHz shall have e.i.r.p. of unwanted emissions comply with the following:

- a) 27 dB m/MHz at frequencies from the band edges decreasing linearly to 15.6 dB m/MHz at 5 MHz above or below the band edges;
- b) 15.6 dB m/MHz at 5 MHz above or below the band edges decreasing linearly to 10 dB m/MHz at 25 MHz above or below the band edges;
- c) 10 dB m/MHz at 25 MHz above or below the band edges decreasing linearly to -27 dB m/MHz at 75 MHz above or below the band edges; and
- d) -27 dB m/MHz at frequencies more than 75 MHz above or below the band edges.

Radiated emissions which fall in the restricted bands, as defined in §15.205(a), must also comply with the radiated emission limits specified in §15.209(a) (see §15.205(c)):

Frequency Range (MHz)	Field Strength Limit (uV/m) at 3 m	Field Strength Limit (dBuV/m) at 3 m
0.009-0.490	2400/F(kHz) @ 300 m	-
0.490-1.705	24000/F(kHz) @ 30 m	-
1.705 - 30	30 @ 30m	-
30 - 88	100	40
88 - 216	150	43.5
216 - 960	200	46
Above 960	500	54

#### FCC §15.205 Restricted bands of operation

MHz	MHz	MHz	GHz
0.090-0.110	16.42-16.423	399.9-410	4.5-5.15
0.495-0.505	16.69475-16.69525	608-614	5.35-5.46
2.1735-2.1905	16.80425-16.80475	960-1240	7.25-7.75
4.125-4.128	25.5-25.67	1300-1427	8.025-8.5
4.17725-4.17775	37.5-38.25	1435-1626.5	9.0-9.2
4.20725-4.20775	73-74.6	1645.5-1646.5	9.3-9.5
6.215-6.218	74.8-75.2	1660-1710	10.6-12.7
6.26775-6.26825	108-121.94	1718.8-1722.2	13.25-13.4
6.31175-6.31225	123-138	2200-2300	14.47-14.5
8.291-8.294	149.9-150.05	2310-2390	15.35-16.2
8.362-8.366	156.52475-156.52525	2483.5-2500	17.7-21.4
8.37625-8.38675	156.7-156.9	2690-2900	22.01-23.12
8.41425-8.41475	162.0125-167.17	3260-3267	23.6-24.0
12.29-12.293	167.72-173.2	3332-3339	31.2-31.8
12.51975-12.52025	240-285	3345.8-3358	36.43-36.5
12.57675-12.57725	322-335.4	3600-4400	
13.36-13.41			

## RSS-GEN 8.10

MHz	MHz	MHz	GHz
0.090 - 0.110	16.42 - 16.423	1660 - 1710	9.0 - 9.2
0.495 - 0.505	16.69475 - 16.69525	1718.8 - 1722.2	9.3 - 9.5
2.1735 - 2.1905	25.5 - 25.67	2200 - 2300	10.6 - 12.7
3.020 - 3.026	37.5 - 38.25	2310 - 2390	13.25 - 13.4
4.125 - 4.128	73 - 74.6	2483.5 - 2500	14.47 - 14.5
4.17725 - 4.17775	74.8 - 75.2	2655 - 2900	15.35 - 16.2
4.20725 - 4.20775	108 - 138	3260 - 3267	17.7 - 21.4
5.677 - 5.683	149.9 - 150.05	3332 - 3339	22.01 - 23.12
6.215 - 6.218	156.52475 - 156.52525	3345.8 - 3358	23.6 - 24.0
6.26775 - 6.26825	156.7 - 156.9	3500 - 4400	31.2 - 31.8
6.31175 - 6.31225	162.0125 - 167.17	4500 - 5150	36.43 - 36.5
8.291 - 8.294	167.72 - 173.2	5350 - 5460	Above 38.6
8.362 - 8.366	240 - 285	7250 - 7750	
8.37625 - 8.38675	322 - 335.4	8025 - 8500	
8.41425 - 8.41475	399.9 - 410		
12.29 - 12.293	608 - 614		
12.51975 - 12.52025	960 - 1427		
12.57675 - 12.57725	1435 - 1626.5		
13.36 - 13.41	1645.5 - 1646.5		

## **4 Test Setup Photos**

Ref "EFGX21030184-IE-01\_Setup\_Photos.pdf"

## **5 External Photo**

Ref "EFGX21030184-IE-02\_External\_Photos.pdf"

## **6 Internal Photos**

Ref "EFGX21030184-IE-03\_Internal\_Photos.pdf"

## **7 Appendix**

Ref "EFGX21030184-IE-01-E09\_appendix.pdf"

**--End of report--**