

# TEST REPORT

Applicant Name: YEALINK(XIAMEN) NETWORK TECHNOLOGY CO.,LTD.  
Address: No.666 Hu'an Rd. Huli District Xiamen City, Fujian, P.R. China  
Report Number: 2401S52962-RFA  
FCC ID: T2C-MCORELITE  
IC: 10741A-MCORELITE

## Test Standard (s)

FCC PART 15.247; RSS-GEN ISSUE 5, FEBRUARY 2021 AMENDMENT 2;  
RSS-247 ISSUE 3, AUGUST 2023

## Sample Description

Product Type: Mini-PC  
Model No.: MCore Lite  
Multiple Model(s) No.: N/A  
Trade Mark: Yealink  
Date Received: 2024/04/07  
Issue Date: 2024/05/23

Test Result:	Pass▲
--------------	-------

▲ In the configuration tested, the EUT complied with the standards above.

## Prepared and Checked By:

*Andy Yu*

Andy Yu  
RF Engineer

## Approved By:

*Nancy Wang*

Nancy Wang  
RF Supervisor

Note: The information marked # is provided by the applicant, the laboratory is not responsible for its authenticity and this information can affect the validity of the result in the test report. Customer model name, addresses, names, trademarks etc. are included.

This report cannot be reproduced except in full, without prior written approval of the Company. Unless otherwise stated the results shown in this test report refer only to the sample(s) tested. This report is valid only with a valid digital signature. The digital signature may be available only under the Adobe software above version 7.0.

This report must not be used by the customer to claim product certification, approval, or endorsement by NVLAP or any agency of the U.S. Government.

This report may contain data that are not covered by the NVLAP accreditation and are marked with an asterisk "▼".

## Bay Area Compliance Laboratories Corp. (Shenzhen)

5F(B-West), 6F, 7F, the 3rd Phase of Wan Li Industrial Building D, Shihua Rd, FuTian Free Trade Zone, Shenzhen, China

Tel: +86-755-33320018 Fax: +86-755-33320008 www.baclcorp.com.cn

## TABLE OF CONTENTS

<b>DOCUMENT REVISION HISTORY .....</b>	<b>4</b>
<b>GENERAL INFORMATION.....</b>	<b>5</b>
PRODUCT DESCRIPTION FOR EQUIPMENT UNDER TEST (EUT).....	5
OBJECTIVE .....	5
TEST METHODOLOGY .....	5
MEASUREMENT UNCERTAINTY .....	6
TEST FACILITY .....	6
<b>SYSTEM TEST CONFIGURATION.....</b>	<b>7</b>
DESCRIPTION OF TEST CONFIGURATION .....	7
EUT EXERCISE SOFTWARE .....	7
SPECIAL ACCESSORIES.....	7
EQUIPMENT MODIFICATIONS .....	7
SUPPORT EQUIPMENT LIST AND DETAILS .....	8
EXTERNAL I/O CABLE.....	8
BLOCK DIAGRAM OF TEST SETUP .....	9
<b>SUMMARY OF TEST RESULTS .....</b>	<b>11</b>
<b>TEST EQUIPMENT LIST .....</b>	<b>12</b>
<b>FCC §15.247 (I) &amp; §1.1307 (B) &amp; §2.1091 - MPE-BASED EXEMPTION .....</b>	<b>14</b>
APPLICABLE STANDARD .....	14
RESULT .....	15
<b>RSS-102 § 4 - EXPOSURE LIMITS .....</b>	<b>16</b>
APPLICABLE STANDARD .....	16
RESULT .....	16
<b>FCC §15.203 &amp; RSS-GEN §6.8 - ANTENNA REQUIREMENT .....</b>	<b>18</b>
APPLICABLE STANDARD .....	18
ANTENNA CONNECTOR CONSTRUCTION .....	18
<b>FCC §15.207 (A) &amp; RSS-GEN § 8.8 - AC LINE CONDUCTED EMISSIONS.....</b>	<b>19</b>
APPLICABLE STANDARD .....	19
EUT SETUP.....	19
EMI TEST RECEIVER SETUP.....	19
TEST PROCEDURE .....	19
FACTOR & OVER LIMIT CALCULATION.....	20
TEST DATA .....	20
<b>FCC §15.209, §15.205 &amp; §15.247(D) &amp; RSS-247§ 5.5 - SPURIOUS EMISSIONS .....</b>	<b>25</b>
APPLICABLE STANDARD .....	25
EUT SETUP.....	25
EMI TEST RECEIVER & SPECTRUM ANALYZER SETUP .....	26
TEST PROCEDURE .....	27
FACTOR & OVER LIMIT/MARGIN CALCULATION .....	27
TEST DATA .....	27

**FCC §15.247(A) (1) & RSS-247 § 5.1 (B) - CHANNEL SEPARATION TEST .....41**  
 APPLICABLE STANDARD .....41  
 TEST PROCEDURE .....41  
 TEST DATA .....42

**FCC §15.247(A) (1) & RSS-247 § 5.1 (A), RSS-GEN § 6.7 - 20 DB EMISSION BANDWIDTH & 99% OCCUPIED BANDWIDTH .....43**  
 APPLICABLE STANDARD .....43  
 TEST PROCEDURE .....43  
 TEST DATA .....44

**FCC §15.247(A) (1) (III) & RSS-247 § 5.1 (D) - QUANTITY OF HOPPING CHANNEL TEST.....45**  
 APPLICABLE STANDARD .....45  
 TEST PROCEDURE .....45  
 TEST DATA .....46

**FCC §15.247(A) (1) (III) & RSS-247 § 5.1 (D) - TIME OF OCCUPANCY (DWELL TIME) .....47**  
 APPLICABLE STANDARD .....47  
 TEST PROCEDURE .....47  
 TEST DATA .....48

**FCC §15.247(B) (1) & RSS-247§ 5.1(B) &§ 5.4(B) - PEAK OUTPUT POWER MEASUREMENT .....49**  
 APPLICABLE STANDARD .....49  
 TEST PROCEDURE .....49  
 TEST DATA .....50

**FCC §15.247(D) & RSS-247 § 5.5 - BAND EDGES TESTING .....51**  
 APPLICABLE STANDARD .....51  
 TEST PROCEDURE .....51  
 TEST DATA .....52

**EUT PHOTOGRAPHS .....53**

**TEST SETUP PHOTOGRAPHS .....54**

**APPENDIX .....55**  
 APPENDIX A: 20dB EMISSION BANDWIDTH.....55  
 APPENDIX B: OCCUPIED CHANNEL BANDWIDTH .....61  
 APPENDIX C: MAXIMUM CONDUCTED OUTPUT POWER .....67  
 APPENDIX D: CARRIER FREQUENCY SEPARATION .....73  
 APPENDIX E: TIME OF OCCUPANCY .....75  
 APPENDIX F: NUMBER OF HOPPING CHANNELS .....85  
 APPENDIX G: BAND EDGE MEASUREMENTS .....87

**DOCUMENT REVISION HISTORY**

Revision Number	Report Number	Description of Revision	Date of Revision
0	2401S52962-RFA	Original Report	2024/05/23

## GENERAL INFORMATION

### Product Description for Equipment under Test (EUT)

HVIN	MCORELITE
FVIN	N/A
Product	Mini-PC
Tested Model	MCore Lite
Multiple Model(s)	N/A
Frequency Range	Bluetooth: 2402-2480MHz
Transmit Power	8.08dBm
Modulation Technique	Bluetooth: GFSK, $\pi/4$ -DQPSK, 8DPSK
Antenna Specification <sup>#</sup>	2.32dBi (provided by the applicant)
Voltage Range	DC 19V from adapter
Sample serial number	2JJC-2 for Conducted and Radiated Emissions Test 2JJC-1 for RF Conducted Test (Assigned by BACL, Shenzhen)
Sample/EUT Status	Good condition
Adapter Information	Model:HKA09019047-6U Input: AC 100-240V~50/60Hz, 1.5A Output: DC 19.0V, 4.74A, 90.06W

### Objective

This test report is in accordance with Part 2-Subpart J, Part 15-Subparts A and C of the Federal Communication Commissions rules and RSS-247 Issue 3, August 2023, RSS-GEN Issue 5, Feb. 2021Amendment 2 of the Innovation, Science and Economic Development Canada rules.

### Test Methodology

All measurements contained in this report were conducted with ANSI C63.10-2013, American National Standard of Procedures for Compliance Testing of Unlicensed Wireless Devices and RSS-247 Issue 3, August 2023, RSS-GEN Issue 5, Feb. 2021Amendment 2 of the Innovation, Science and Economic Development Canada rules.

All emissions measurement was performed at Bay Area Compliance Laboratories Corp. (Shenzhen). The radiated testing was performed at an antenna-to-EUT distance of 3 meters.

Each test item follows test standards and with no deviation.

**Measurement Uncertainty**

Parameter		Uncertainty
Occupied Channel Bandwidth		±5%
RF output power, conducted		0.72 dB(k=2, 95% level of confidence)
AC Power Lines Conducted Emissions	9kHz-150kHz	3.94dB(k=2, 95% level of confidence)
	150kHz-30MHz	3.84dB(k=2, 95% level of confidence)
Radiated Emissions	9kHz - 30MHz	3.30dB(k=2, 95% level of confidence)
	30MHz~200MHz (Horizontal)	4.48dB(k=2, 95% level of confidence)
	30MHz~200MHz (Vertical)	4.55dB(k=2, 95% level of confidence)
	200MHz~1000MHz (Horizontal)	4.85dB(k=2, 95% level of confidence)
	200MHz~1000MHz (Vertical)	5.05dB(k=2, 95% level of confidence)
	1GHz - 6GHz	5.35dB(k=2, 95% level of confidence)
	6GHz - 18GHz	5.44dB(k=2, 95% level of confidence)
18GHz - 40GHz	5.16dB(k=2, 95% level of confidence)	
Temperature		±1°C
Humidity		±1%
Supply voltages		±0.4%

*Note: The extended uncertainty given in this report is obtained by combining the standard uncertainty times the coverage factor K with the 95% confidence interval. Otherwise required by the applicant or Product Regulations, Decision Rule in this report did not consider the uncertainty.*

**Test Facility**

The Test site used by Bay Area Compliance Laboratories Corp. (Shenzhen) to collect test data is located on the 5F(B-West) , 6F, 7F, the 3rd Phase of Wan Li Industrial Building D, Shihua Rd, FuTian Free Trade Zone, Shenzhen, China.

The lab has been recognized as the FCC accredited lab under the KDB 974614 D01 and is listed in the FCC Public Access Link (PAL) database, FCC Registration No. : 715558, the FCC Designation No. : CN5045.

The lab has been recognized by Innovation, Science and Economic Development Canada to test to Canadian radio equipment requirements, the CAB identifier: CN0023.

## SYSTEM TEST CONFIGURATION

### Description of Test Configuration

The system was configured for testing in an engineering mode.

Channel	Frequency (MHz)	Channel	Frequency (MHz)
0	2402	40	2442
1	2403	41	2443
2	2404	42	2444
...	...	...	...
...	...	...	...
36	2438	75	2477
37	2439	76	2478
38	2440	77	2479
39	2441	78	2480

EUT was tested with Channel 0, 39 and 78.

### EUT Exercise Software

“DRTU #” exercise software was used, GFSK power level is 4<sup>#</sup>,  $\pi/4$ -DQPSK power level is 3<sup>#</sup> and 8DPSK power level is 5<sup>#</sup>. The software and power level was provided by the applicant.

### Special Accessories

No special accessory.

### Equipment Modifications

No modification was made to the EUT tested.

**Support Equipment List and Details**

Manufacturer	Description	Model	Serial Number
Sandisk	U disk *2	Unknown	Unknown
NEWMEN	Keyboard	KM-201	Unknown
Rapoo	Mouse	N100	A2602N1200069844
Redmi	Monitor	A22FAB-RA	47366/206100029128
HIKVISION	Router	DS-3WR03	10021642429
Yealink	Touch Panel	M Touch plus	Unknown

**External I/O Cable**

Cable Description	Length (m)	From Port	To
Unshielded un-detachable AC cable	1.2	LISN1/ AC Mains	Receptacle
Unshielded detachable AC cable	0.5	Receptacle	Adapter
Shielded Un-detachable DC cable	1.5	Adapter	EUT
Un-Shielded Un-detachable USB cable	1.5	Keyboard	EUT
Un-Shielded Un-detachable USB cable	1.2	Mouse	EUT
Shielded detachable HDMI cable	1.6	EUT	Monitor
Shielded detachable AC cable	2.0	LISN2/ AC Mains	Monitor
Shielded detachable RJ45 cable	5.0	EUT	Router
Unshielded detachable AC cable	1.2	LISN2/ AC Mains	Router
Shielded detachable RJ45 cable	5.0	EUT	Touch panel



### Block Diagram of Test Setup

For Conducted Emissions:

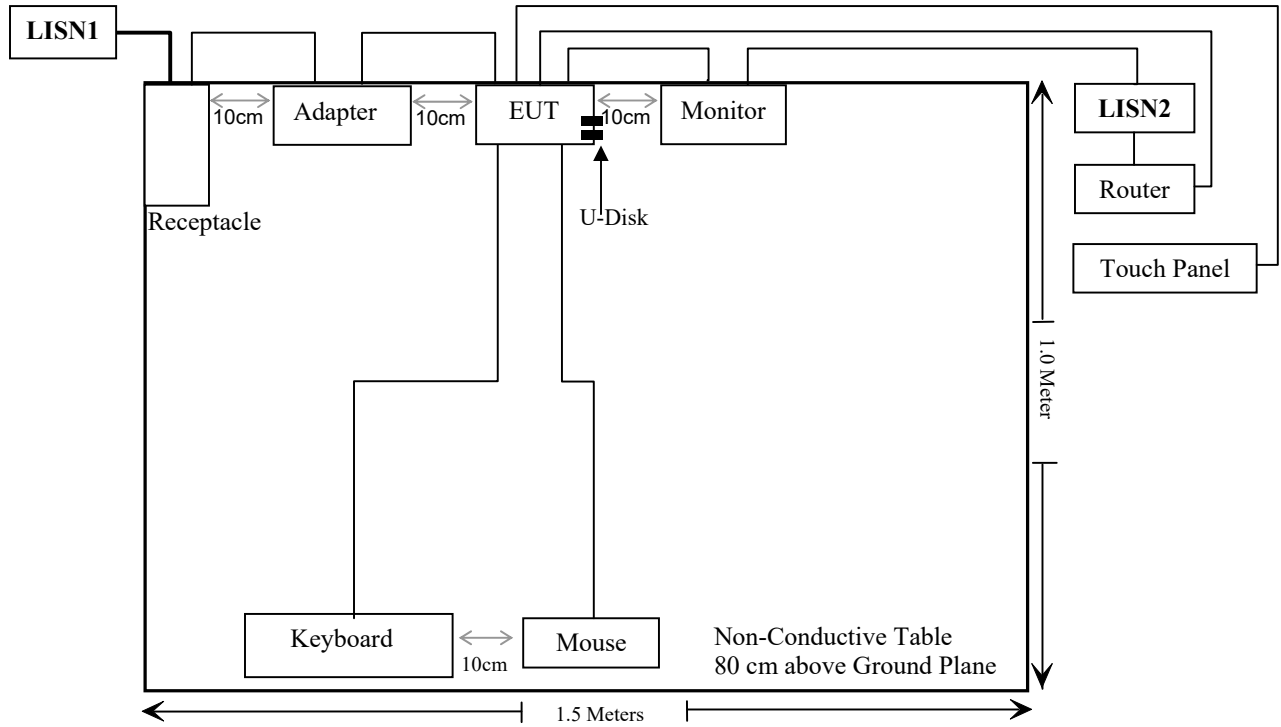

Radiated Emissions (below 1GHz):

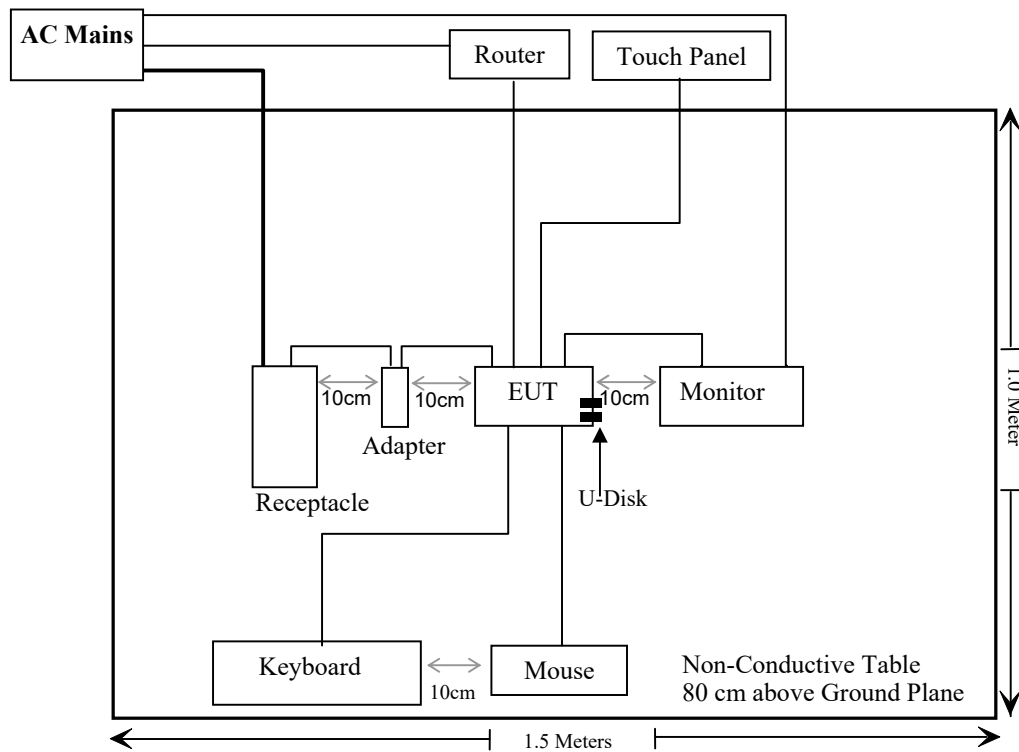

Radiated Emissions (above 1GHz):

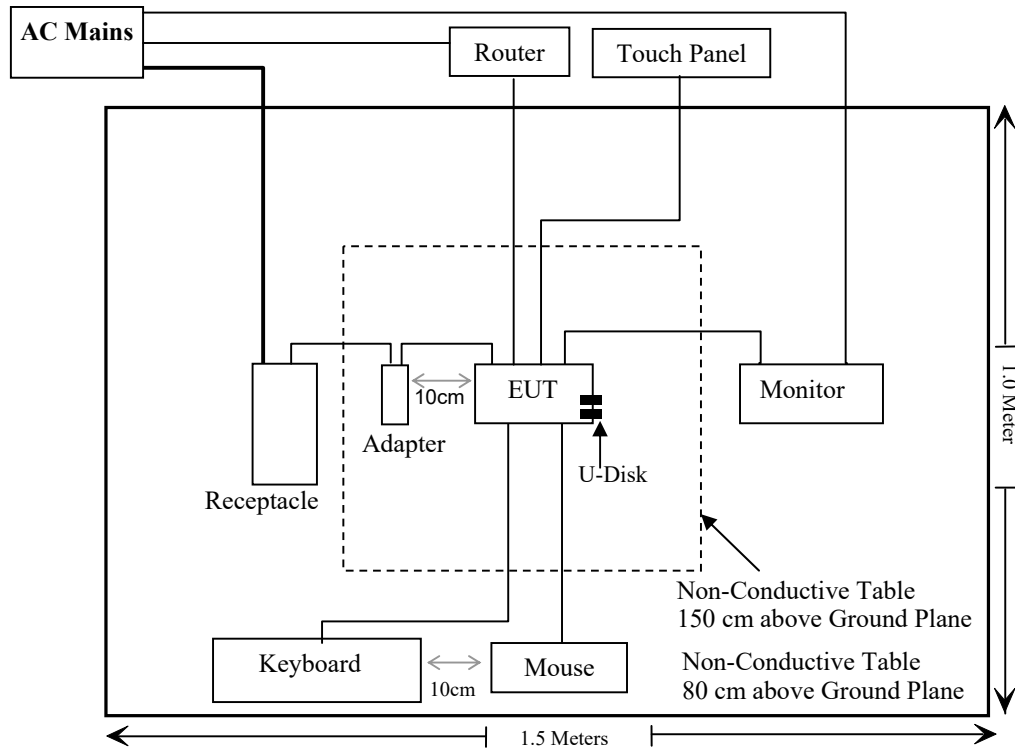

## SUMMARY OF TEST RESULTS

Rules	Description of Test	Result
FCC §15.247 (i), §1.1307 (b) & §2.1091	MPE-Based Exemption	Compliant
RSS-102 § 4	Exposure Limits	Compliant
FCC §15.203 RSS-Gen §6.8	Antenna Requirement	Compliant
FCC §15.207(a) RSS-Gen §8.8	AC Line Conducted Emissions	Compliant
FCC §15.205, §15.209, §15.247(d) RSS-247 § 5.5, RSS-GEN § 8.10	Radiated Emissions	Compliant
FCC §15.247(a)(1) RSS-247 § 5.1(a), RSS-GEN § 6.7	20 dB Emission Bandwidth & 99% Occupied Bandwidth	Compliant
FCC §15.247(a)(1) RSS-247 § 5.1 (b)	Channel Separation Test	Compliant
FCC §15.247(a)(1)(iii) RSS-247 § 5.1 (d)	Time of Occupancy (Dwell Time)	Compliant
FCC §15.247(a)(1)(iii) RSS-247 § 5.1 (d)	Quantity of hopping channel Test	Compliant
FCC §15.247(b)(1) RSS-247 § 5.1(b) & § 5.4(b)	Peak Output Power Measurement	Compliant
FCC §15.247(d) RSS-247 § 5.5	Band edges	Compliant

**TEST EQUIPMENT LIST**

Manufacturer	Description	Model	Serial Number	Calibration Date	Calibration Due Date
<b>Conducted Emission Test</b>					
Rohde & Schwarz	EMI Test Receiver	ESCI	101120	2024/01/16	2025/01/15
Rohde & Schwarz	LISN	ENV216	101613	2024/01/16	2025/01/15
Rohde & Schwarz	Transient Limiter	ESH3Z2	DE25985	2023/08/03	2024/08/02
Unknown	CE Cable	CE Cable	UF A210B-1-0720-504504	2023/08/03	2024/08/02
Audix	EMI Test software	E3	191218(V9)	NCR	NCR
<b>Radiated Emission Test</b>					
R&S	EMI Test Receiver	ESR3	102455	2024/01/16	2025/01/15
Sonoma instrument	Pre-amplifier	310 N	186238	2023/06/08	2024/06/07
Sunol Sciences	Broadband Antenna	JB1	A040904-1	2023/07/20	2026/07/19
BACL	Active Loop Antenna	1313-1A	4031911	2024/03/21	2025/03/20
Unknown	Cable	Chamber Cable 1	F-03-EM236	2023/08/03	2024/08/02
Unknown	Cable	Chamber Cable 4	EC-007	2023/08/03	2024/08/02
Audix	EMI Test software	E3	19821b(V9)	NCR	NCR
Rohde & Schwarz	Spectrum Analyzer	FSV40	101605	2024/03/27	2025/03/26
COM-POWER	Pre-amplifier	PA-122	181919	2023/06/29	2024/06/28
Schwarzbeck	Horn Antenna	BBHA9120D(1201)	1143	2023/07/26	2026/07/25
Unknown	RF Cable	KMSE	0735	2023/10/08	2024/10/07
Unknown	RF Cable	UFA147	219661	2023/10/08	2024/10/07
JD	Multiplex Switch Test Control Set	DT7220FSU	DQ77926	NCR	NCR
SNSD	2.4G Band Reject filter	BSF2402-2480MN-0898-001	2.4G filter	2023/08/03	2024/08/02
Audix	EMI Test software	E3	191218(V9)	NCR	NCR
A.H.System	Pre-amplifier	PAM-1840VH	190	2023/08/02	2024/08/01
Electro-Mechanics Co	Horn Antenna	3116	9510-2270	2023/09/18	2026/09/17
UTIFLEX	RF Cable	NO. 13	232308-001	2023/08/03	2024/08/02

Manufacturer	Description	Model	Serial Number	Calibration Date	Calibration Due Date
<b>RF Conducted Test</b>					
Tonscend	RF control Unit	JS0806-2	19D8060154	2023/09/06	2024/09/05
Rohde & Schwarz	Signal and Spectrum Analyzer	FSV40	101473	2024/01/16	2025/01/15
MARCONI	10dB Attenuator	6534/3	2942	2023/07/04	2024/07/03
Unknown	RF Cable	65475	01670515	2023/07/04	2024/07/03

\* **Statement of Traceability:** Bay Area Compliance Laboratories Corp. (Shenzhen) attests that all calibrations have been performed in accordance to requirements that traceable to National Primary Standards and International System of Units (SI).

**FCC §15.247 (I) & §1.1307 (B) & §2.1091 - MPE-BASED EXEMPTION**

**Applicable Standard**

According to subpart 15.247 (i) and subpart 2.1091 systems operating under the provisions of this section shall be operated in a manner that ensures the public is not exposed to RF energy level in excess of the communication guidelines.

According to KDB 447498 D04 Interim General RF Exposure Guidance

MPE-Based Exemption:

General frequency and separation-distance dependent MPE-based effective radiated power(ERP) thresholds are in Table B.1 [Table 1 of § 1.1307(b)(1)(i)(C)] to support an exemption from further evaluation from 300 kHz through 100 GHz.

Table 1 to § 1.1307(b)(3)(i)(C) - Single RF Sources Subject to Routine Environmental Evaluation

RF Source frequency (MHz)	Threshold ERP (watts)
0.3-1.34	1,920 R <sup>2</sup> .
1.34-30	3,450 R <sup>2</sup> /f <sup>2</sup> .
30-300	3.83 R <sup>2</sup> .
300-1,500	0.0128 R <sup>2</sup> f.
1,500-100,000	19.2R <sup>2</sup> .

R is the minimum separation distance in meters  
 f = frequency in MHz

For multiple RF sources: Multiple RF sources are exempt if:

in the case of fixed RF sources operating in the same time-averaging period, or of multiple mobile or portable RF sources within a device operating in the same time averaging period, if the sum of the fractional contributions to the applicable thresholds is less than or equal to 1 as indicated in the following equation:

$$\sum_{i=1}^a \frac{P_i}{P_{th,i}} + \sum_{j=1}^b \frac{ERP_j}{ERP_{th,j}} + \sum_{k=1}^c \frac{Evaluated_k}{Exposure\ Limit_k} \leq 1$$

**Result**

Mode	Frequency (MHz)	Tune up conducted power <sup>#</sup>	Antenna Gain <sup>#</sup>		ERP		Evaluation Distance (m)	ERP Limit (mW)
		(dBm)	(dBi)	(dBd)	(dBm)	(mW)		
BT	2402-2480	8.5	2.86	0.71	9.21	8.34	0.2	768
BLE	2402-2480	5.5	2.86	0.71	6.21	4.18	0.2	768
2.4G Wi-Fi	2412-2472	21.0	2.86	0.71	21.71	148.25	0.2	768
5.2G Wi-Fi	5180-5240	16.0	4.97	2.82	18.82	76.21	0.2	768
5.3G Wi-Fi	5260-5320	16.0	4.97	2.82	18.82	76.21	0.2	768
5.6G Wi-Fi	5500-5720	16.0	4.97	2.82	18.82	76.21	0.2	768
5.8G Wi-Fi	5745-5825	16.0	4.97	2.82	18.82	76.21	0.2	768

- Note: 1. The tune up conducted power and antenna gain was declared by the applicant.  
 2. The BT, 2.4G Wi-Fi and 5G Wi-Fi can transmit at same time.  
 3. 0dBd=2.15dBi

Simultaneous transmitting consideration (worst case):

The ratio= $ERP_{BT}/limit + ERP_{2.4G\ Wi-Fi}/limit + ERP_{5G\ Wi-Fi}/limit = 8.34/768 + 148.25/768 + 76.21/768 = 0.303 < 1.0$ , so simultaneous exposure is compliant.

To maintain compliance with the FCC’s RF exposure guidelines, place the equipment at least 20cm from nearby persons.

**Result: Compliant.**

## RSS-102 § 4 - EXPOSURE LIMITS

### Applicable Standard

According to RSS-102 §4:

**Table 4: RF Field Strength Limits for Devices Used by the General Public (Uncontrolled Environment)**

Frequency Range (MHz)	Electric Field (V/m rms)	Magnetic Field (A/m rms)	Power Density (W/m <sup>2</sup> )	Reference Period (minutes)
0.003-10 <sup>21</sup>	83	90	-	Instantaneous <sup>*</sup>
0.1-10	-	0.73/ f	-	6 <sup>**</sup>
1.1-10	87/ f <sup>0.5</sup>	-	-	6 <sup>**</sup>
10-20	27.46	0.0728	-2	6
20-48	58.07/ f <sup>0.25</sup>	0.1540/ f <sup>0.25</sup>	8.944/ f <sup>0.5</sup>	6
48-300	22.06	0.05852	1.291	6
300-6000	3.142 f <sup>0.3417</sup>	0.008335 f <sup>0.3417</sup>	0.02619 f <sup>0.6834</sup>	6
6000-15000	61.4	0.163	10	6
15000-150000	61.4	0.163	10	616000/ f <sup>1.2</sup>
150000-300000	0.158 f <sup>0.5</sup>	4.21 x 10 <sup>-4</sup> f <sup>0.5</sup>	6.67 x 10 <sup>-5</sup> f	616000/f

Note: f is frequency in MHz.

<sup>\*</sup> Based on nerve stimulation (NS).

<sup>\*\*</sup> Based on specific absorption rate (SAR).

### Result

#### Calculated Formulary:

Predication of MPE limit at a given distance

$$S = \frac{PG}{4\pi R^2}$$

S = power density (in appropriate units, e.g. W/m<sup>2</sup>)

P = power input to the antenna (in appropriate units, e.g., W).

G = power gain of the antenna in the direction of interest relative to an isotropic radiator, the power gain factor, is normally numeric gain.

R = distance to the center of radiation of the antenna (appropriate units, e.g., m)

For simultaneously transmit system, the calculated power density should comply with:

$$\sum_i \frac{S_i}{S_{Limit,i}} \leq 1$$



For worst case:

Mode	Frequency (MHz)	Antenna Gain <sup>#</sup>		Max Tune-up Power <sup>#</sup>		Evaluation Distance (m)	Power Density (W/m <sup>2</sup> )	MPE Limit (W/m <sup>2</sup> )
		(dBi)	(numeric)	(dBm)	(mW)			
BT	2402-2480	2.86	1.93	8.5	7.08	0.2	0.027	5.35
BLE	2402-2480	2.86	1.93	5.5	3.55	0.2	0.014	5.35
2.4G Wi-Fi	2412-2472	2.86	1.93	21.0	125.89	0.2	0.483	5.37
5.2G Wi-Fi	5180-5240	4.97	3.14	16.0	39.81	0.2	0.249	9.05
5.3G Wi-Fi	5260-5320	4.97	3.14	16.0	39.81	0.2	0.249	9.14
5.6G Wi-Fi	5500-5720	4.97	3.14	16.0	39.81	0.2	0.249	9.43
5.8G Wi-Fi	5745-5825	4.97	3.14	16.0	39.81	0.2	0.249	9.71

Note: 1. The tune up conducted power and antenna gain was declared by the applicant.  
 2. The BT, 2.4G Wi-Fi and 5G Wi-Fi can transmit at same time.

Simultaneous transmitting consideration (worst case):

The ratio=  $MPE_{BT}/limit + MPE_{2.4G\ Wi-Fi}/limit + MPE_{5G\ Wi-Fi}/limit = 0.027/5.35 + 0.483/5.37 + 0.249/9.05 = 0.123 < 1.0$ , so simultaneous exposure is compliant.

**Result: Compliant.**

Note: To maintain compliance with the RF exposure guidelines, place the equipment at least 0.2 m from nearby persons.

## FCC §15.203 & RSS-GEN §6.8 - ANTENNA REQUIREMENT

### Applicable Standard

According to FCC § 15.203, an intentional radiator shall be designed to ensure that no antenna other than that furnished by the responsible party shall be used with the device. The use of a permanently attached antenna or of an antenna that uses a unique coupling to the intentional radiator shall be considered sufficient to comply with the provisions of this Section. The manufacturer may design the unit so that a broken antenna can be replaced by the user, but the use of a standard antenna jack or electrical connector is prohibited.

According to FCC § 15.203, the applicant for equipment certification shall provide a list of all antenna types that may be used with the transmitter, where applicable (i.e. for transmitters with detachable antenna), indicating the maximum permissible antenna gain (in dBi) and the required impedance for each antenna. The test report shall demonstrate the compliance of the transmitter with the limit for maximum equivalent isotropically radiated power (e.i.r.p.) specified in the applicable RSS, when the transmitter is equipped with any antenna type, selected from this list.

For expediting the testing, measurements may be performed using only the antenna with highest gain of each combination of transmitter and antenna type, with the transmitter output power set at the maximum level. However, the transmitter shall comply with the applicable requirements under all operational conditions and when in combination with any type of antenna from the list provided in the test report (and in the notice to be included in the user manual, provided below).

When measurements at the antenna port are used to determine the RF output power, the effective gain of the device’s antenna shall be stated, based on a measurement or on data from the antenna’s manufacturer.

The test report shall state the RF power, output power setting and spurious emission measurements with each antenna type that is used with the transmitter being tested.

For licence-exempt equipment with detachable antennas, the user manual shall also contain the following notice in a conspicuous location:

This radio transmitter [enter the device’s ISED certification number] has been approved by Innovation, Science and Economic Development Canada to operate with the antenna types listed below, with the maximum permissible gain indicated. Antenna types not included in this list that have a gain greater than the maximum gain indicated for any type listed are strictly prohibited for use with this device.

Immediately following the above notice, the manufacturer shall provide a list of all antenna types which can be used with the transmitter, indicating the maximum permissible antenna gain (in dBi) and the required impedance for each antenna type.

### Antenna Connector Construction

The EUT has one internal antenna arrangement which was permanently attached for Bluetooth and the maximum antenna gain<sup>#</sup> is 2.32dBi, fulfill the requirement of this section. Please refer to the EUT photos.

Antenna Type	Antenna Gain <sup>#</sup>	Impedance	Frequency Range
PCB	2.32dBi	50Ω	2.4~2.5GHz

**Result: Compliant**

## FCC §15.207 (a) & RSS-GEN § 8.8 - AC LINE CONDUCTED EMISSIONS

### Applicable Standard

FCC §15.207(a), RSS-GEN § 8.8

### EUT Setup

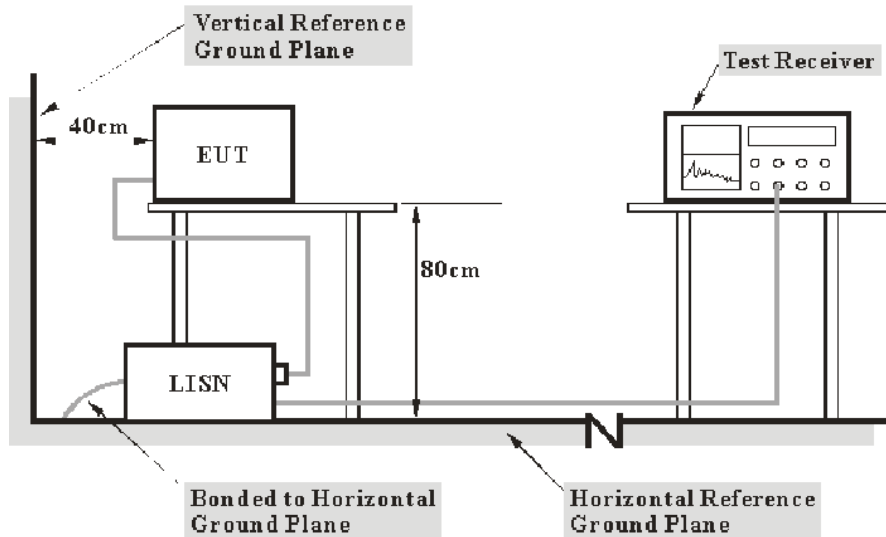

- Note: 1. Support units were connected to second LISN.  
 2. Both of LISNs (AMN) 80 cm from EUT and at the least 80 cm from other units and other metal planes support units.

The measurement procedure of EUT setup is according with ANSI C63.10-2013. The related limit was specified in FCC Part 15.207 & RSS-Gen.

The spacing between the peripherals was 10 cm.

### EMI Test Receiver Setup

The EMI test receiver was set to investigate the spectrum from 150 kHz to 30 MHz.

During the conducted emission test, the EMI test receiver was set with the following configurations:

Frequency Range	IF B/W
150 kHz – 30 MHz	9 kHz

### Test Procedure

Maximizing procedure was performed on the six (6) highest emissions of the EUT.

All final data was recorded in the Quasi-peak and average detection mode.

**Factor & Over Limit Calculation**

The factor is calculated by adding LISN VDF (Voltage Division Factor) and Cable Loss. The basic equation is as follows:

$$\text{Factor} = \text{LISN VDF} + \text{Cable Loss}$$

The “**Over limit**” column of the following data tables indicates the degree of compliance with the applicable limit. For example, an Over limit of -7 dB means the emission is 7 dB below the limit. The equation for calculation is as follows:

$$\begin{aligned} \text{Over Limit} &= \text{Level} - \text{Limit} \\ \text{Level} &= \text{Read Level} + \text{Factor} \end{aligned}$$

Note: The term "cable loss" refers to the combination of a cable and a 10dB transient limiter (attenuator).

**Test Data**

**Environmental Conditions**

<b>Temperature:</b>	25 °C
<b>Relative Humidity:</b>	70 %
<b>ATM Pressure:</b>	101 kPa

*The testing was performed by Macy Shi on 2024-05-06.*

*EUT operation mode: Transmitting (Maximum output power mode, EDR (8DPSK) High Channel)*

AC 120V/60 Hz, Line

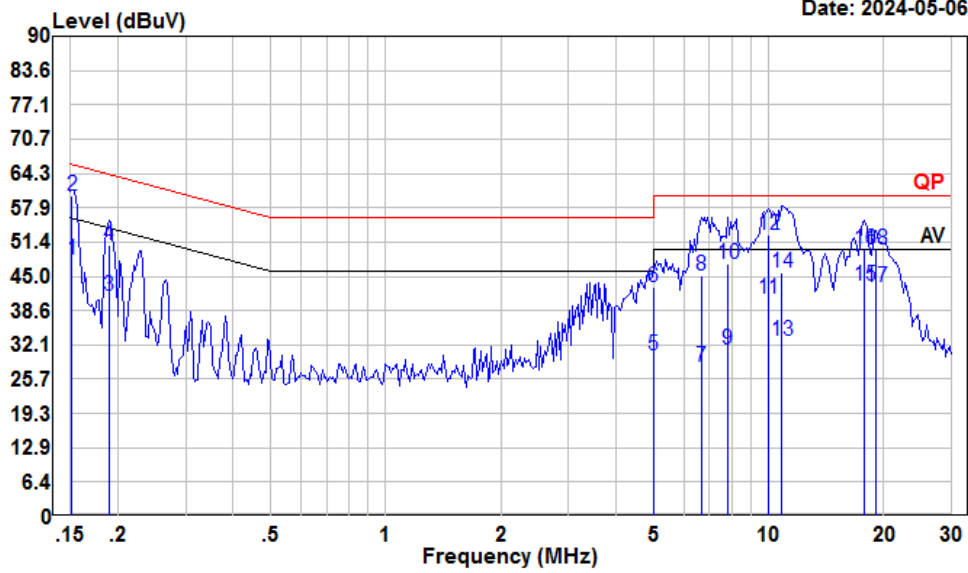

Condition: Line  
 Project : 2401S52962-RF  
 Tester : Macy shi  
 Note : BT

	Read Freq	Read Level	LISN Level	LISN Factor	Cable Loss	Limit Line	Over Limit	Remark
	MHz	dBuV	dBuV	dB	dB	dBuV	dB	
1	0.15	27.21	48.26	10.90	10.15	55.91	-7.65	Average
2	0.15	39.16	60.21	10.90	10.15	65.91	-5.70	QP
3	0.19	20.50	41.43	10.82	10.11	54.06	-12.63	Average
4	0.19	29.80	50.73	10.82	10.11	64.06	-13.33	QP
5	5.00	9.69	30.29	10.38	10.22	50.00	-19.71	Average
6	5.00	22.30	42.90	10.38	10.22	60.00	-17.10	QP
7	6.66	7.40	28.10	10.48	10.22	50.00	-21.90	Average
8	6.66	24.50	45.20	10.48	10.22	60.00	-14.80	QP
9	7.81	10.60	31.36	10.53	10.23	50.00	-18.64	Average
10	7.81	26.50	47.26	10.53	10.23	60.00	-12.74	QP
11	9.97	19.90	40.76	10.60	10.26	50.00	-9.24	Average
12	9.97	32.00	52.86	10.60	10.26	60.00	-7.14	QP
13	10.85	12.11	32.94	10.60	10.23	50.00	-17.06	Average
14	10.85	24.74	45.57	10.60	10.23	60.00	-14.43	QP
15	17.85	22.30	43.19	10.78	10.11	50.00	-6.81	Average
16	17.85	29.20	50.09	10.78	10.11	60.00	-9.91	QP

	Freq	Read Level	LISN Level	Cable Factor	Cable Loss	Limit Line	Over Limit	Remark
	MHz	dBuV	dBuV	dB	dB	dBuV	dB	
17	19.02	22.10	43.06	10.85	10.11	50.00	-6.94	Average
18	19.02	29.00	49.96	10.85	10.11	60.00	-10.04	QP

AC 120V/60 Hz, Neutral

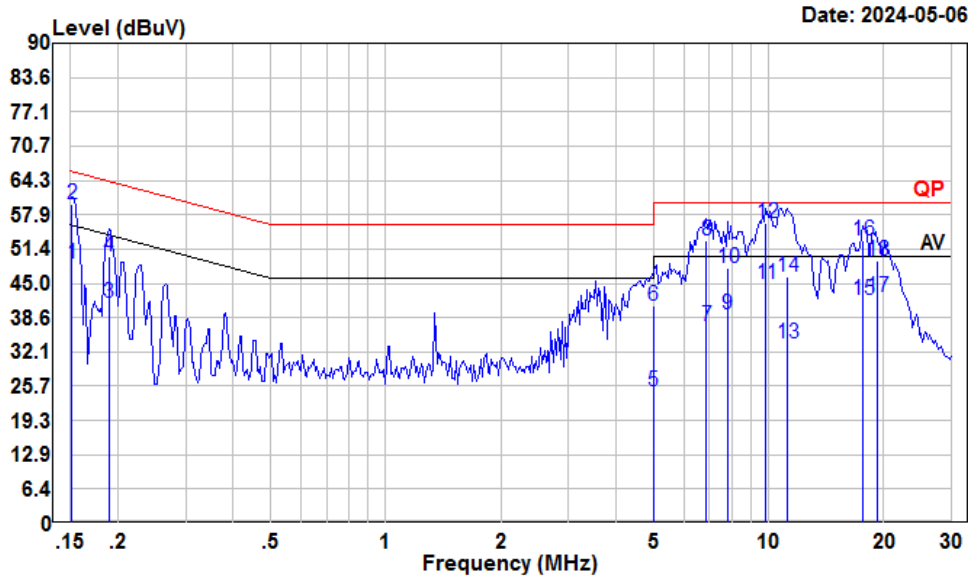

Date: 2024-05-06

Condition: Neutral  
 Project : 2401S52962-RF  
 Tester : Macy shi  
 Note : BT

	Read Freq	Read Level	LISN Level	LISN Factor	Cable Loss	Limit Line	Over Limit	Remark
	MHz	dBuV	dBuV	dB	dB	dBuV	dB	
1	0.15	27.85	48.59	10.59	10.15	55.91	-7.32	Average
2	0.15	39.14	59.88	10.59	10.15	65.91	-6.03	QP
3	0.19	20.90	41.45	10.44	10.11	54.06	-12.61	Average
4	0.19	29.50	50.05	10.44	10.11	64.06	-14.01	QP
5	5.00	4.02	24.76	10.52	10.22	50.00	-25.24	Average
6	5.00	20.02	40.76	10.52	10.22	60.00	-19.24	QP
7	6.88	16.20	37.11	10.69	10.22	50.00	-12.89	Average
8	6.88	32.20	53.11	10.69	10.22	60.00	-6.89	QP
9	7.81	18.30	39.26	10.73	10.23	50.00	-10.74	Average
10	7.81	26.80	47.76	10.73	10.23	60.00	-12.24	QP
11	9.86	23.89	44.95	10.80	10.26	50.00	-5.05	Average
12	9.86	35.29	56.35	10.80	10.26	60.00	-3.65	QP
13	11.20	12.71	33.73	10.80	10.22	50.00	-16.27	Average
14	11.20	25.09	46.11	10.80	10.22	60.00	-13.89	QP
15	17.66	21.00	41.85	10.74	10.11	50.00	-8.15	Average
16	17.66	32.30	53.15	10.74	10.11	60.00	-6.85	QP

	Freq	Read Level	LISN Level	LISN Factor	Cable Loss	Limit Line	Over Limit	Remark
	MHz	dBuV	dBuV	dB	dB	dBuV	dB	
17	19.22	21.50	42.32	10.71	10.11	50.00	-7.68	Average
18	19.22	28.30	49.12	10.71	10.11	60.00	-10.88	QP



# FCC §15.209, §15.205 & §15.247(D) & RSS-247§ 5.5 - SPURIOUS EMISSIONS

## Applicable Standard

FCC §15.205; §15.209; §15.247(d); RSS-247§ 5.5; RSS-GEN § 8.10

## EUT Setup

9 kHz-30MHz:

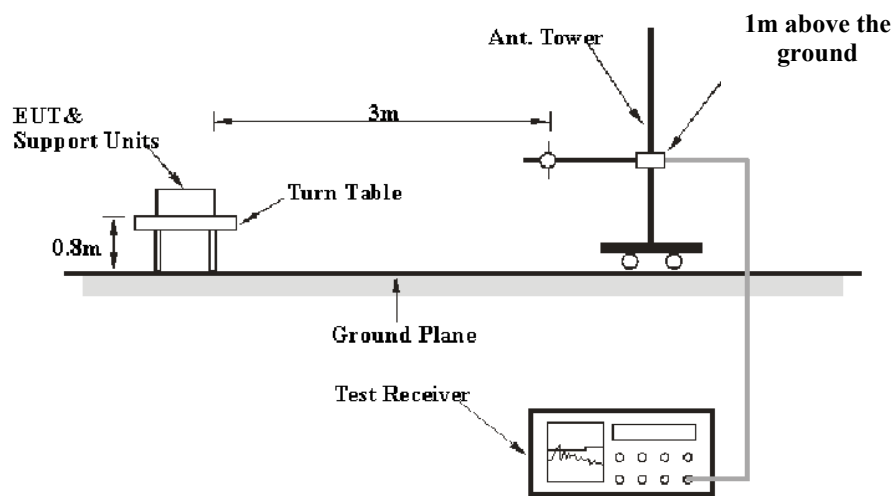

30MHz-1GHz:

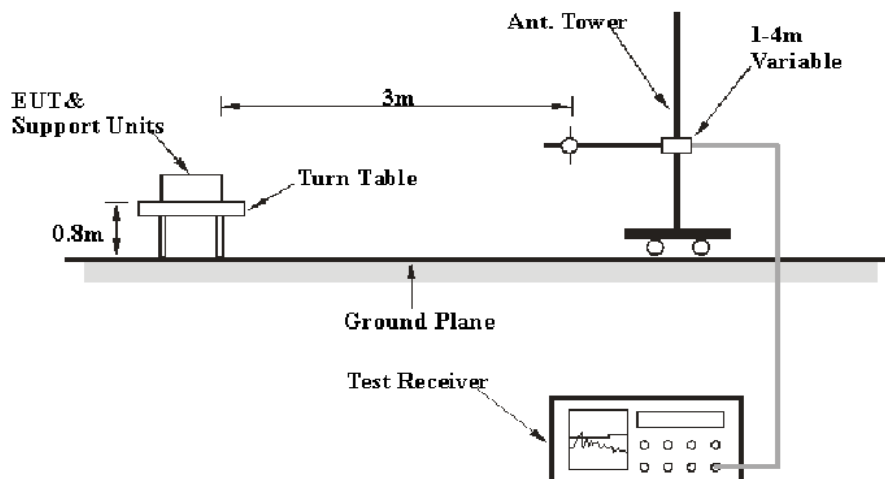

**Above 1GHz:**

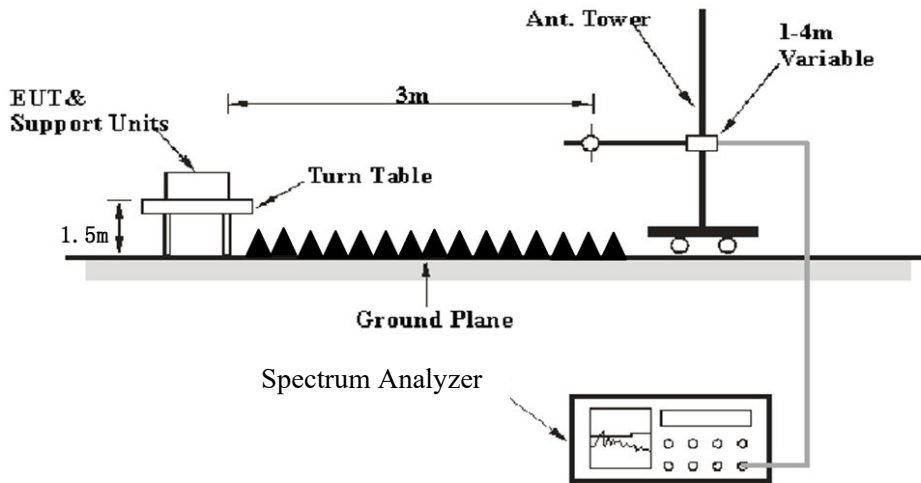

The radiated emission performed in the 3 meters, using the setup accordance with the ANSI C63.10-2013. The specification used was the FCC 15.209, FCC 15.247, RSS-247, RSS-Gen limits.

**EMI Test Receiver & Spectrum Analyzer Setup**

The EMI test receiver & Spectrum Analyzer Setup were set with the following configurations:

Frequency Range	RBW	Video B/W	IF B/W	Measurement
9 kHz – 150 kHz	/	/	200 Hz	QP
	300 Hz	1 kHz	/	PK
150 kHz – 30 MHz	/	/	9 kHz	QP
	10 kHz	30 kHz	/	PK
30 MHz – 1000 MHz	/	/	120 kHz	QP
	100 kHz	300 kHz	/	PK
Above 1 GHz	Harmonics & Band Edge			
	1MHz	3 MHz	/	PK
	Average Emission Level=Peak Emission Level+20*log(Duty cycle)			
	Other Emissions			
	1MHz	3 MHz	/	PK
	1MHz	10 Hz	/	Average

For Duty cycle measurement:

Use the duty cycle factor correction factor method per 15.35(c).

Duty cycle=On time/100milliseconds, On time= $N1*L1+N2*L2+...Nn-1*Ln-1+Nn*Ln$ ,

Where N1 is number of type 1 pulses, L1 is length of type 1 pulse, etc.

**Test Procedure**

Maximizing procedure was performed on the highest emissions to ensure that the EUT complied with all installation combinations.

All final data was recorded in Quasi-peak detection mode except for the frequency bands 9–90 kHz, 110–490 kHz and above 1000 MHz, average detection modes for frequency bands 9–90 kHz and 110–490 kHz, peak and average detection modes for frequencies above 1 GHz.

For 9 kHz-30MHz, the report shall list the six emissions with the smallest margin relative to the limit, for each of the three antenna orientations (parallel, perpendicular, and ground-parallel) unless the margin is greater than 20 dB.

If the maximized peak measured value complies with under the QP/Average limit more than 6dB, then it is unnecessary to perform an QP/Average measurement.

All emissions under the average limit and under the noise floor have not recorded in the report.

**Factor & Over Limit/Margin Calculation**

The Factor is calculated by adding the Antenna Factor and Cable Loss, and subtracting the Amplifier Gain. The basic equation is as follows:

$$\text{Factor} = \text{Antenna Factor} + \text{Cable Loss} - \text{Amplifier Gain}$$

The “**Over Limit/Margin**” column of the following data tables indicates the degree of compliance with the applicable limit. For example, an Over Limit/margin of -7dB means the emission is 7dB below the limit. The equation for calculation is as follows:

$$\begin{aligned} \text{Over Limit/Margin} &= \text{Level} / \text{Corrected Amplitude} - \text{Limit} \\ \text{Level} / \text{Corrected Amplitude} &= \text{Read Level} + \text{Factor} \end{aligned}$$

**Test Data**

**Environmental Conditions**

<b>Temperature:</b>	22~25.3 °C
<b>Relative Humidity:</b>	50~58 %
<b>ATM Pressure:</b>	101 kPa

*The testing was performed by Anson Su on 2024-04-29 for below 1GHz and Tyler Wu on 2024-04-25 and Zenos Qiao on 2024-04-27 for above 1GHz.*

*EUT operation mode: Transmitting*

*Note: Pre-scan in the X, Y and Z axes of orientation, the worst case z-axis of orientation was recorded.*

**9 kHz-30MHz:** (Maximum output power mode, EDR (8DPSK) High Channel)

The amplitude of spurious emissions attenuated more than 20 dB below the limit was not recorded.

**30MHz-1GHz:** (Maximum output power mode, EDR (8DPSK) High Channel)

**Horizontal**

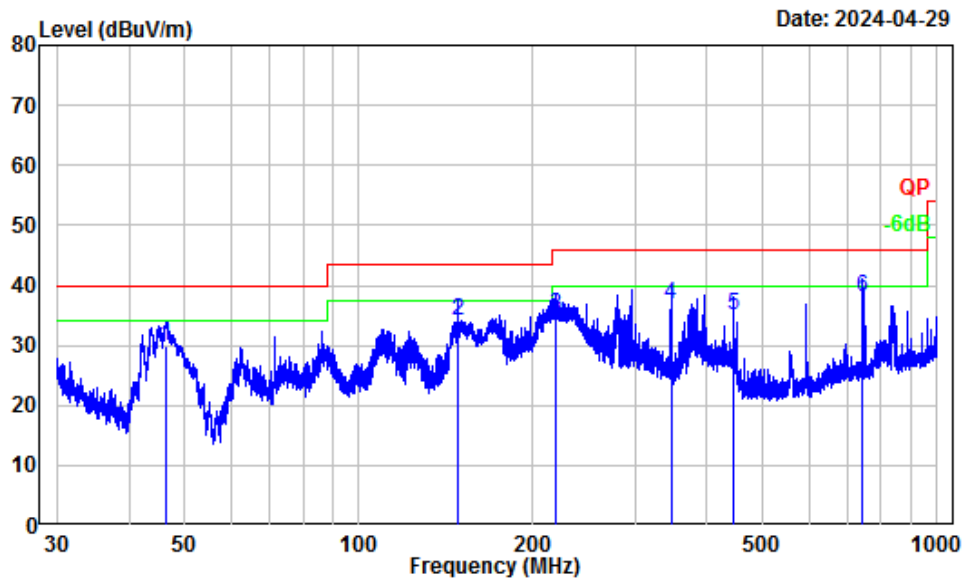

Site : Chamber A  
 Condition : 3m Horizontal  
 Project Number: 2401S52962-RF  
 Note : BT  
 Tester : Anson Su

	Freq	Factor	Read Level	Limit Level	Limit Line	Over Limit	Remark
	MHz	dB/m	dBuV	dBuV/m	dBuV/m	dB	
1	46.32	-14.39	44.28	29.89	40.00	-10.11	QP
2	148.44	-11.25	45.50	34.25	43.50	-9.25	QP
3	219.75	-11.35	46.47	35.12	46.00	-10.88	QP
4	346.51	-9.86	46.84	36.98	46.00	-9.02	QP
5	445.83	-5.77	40.80	35.03	46.00	-10.97	QP
6	742.58	-1.64	39.61	37.97	46.00	-8.03	QP

Vertical

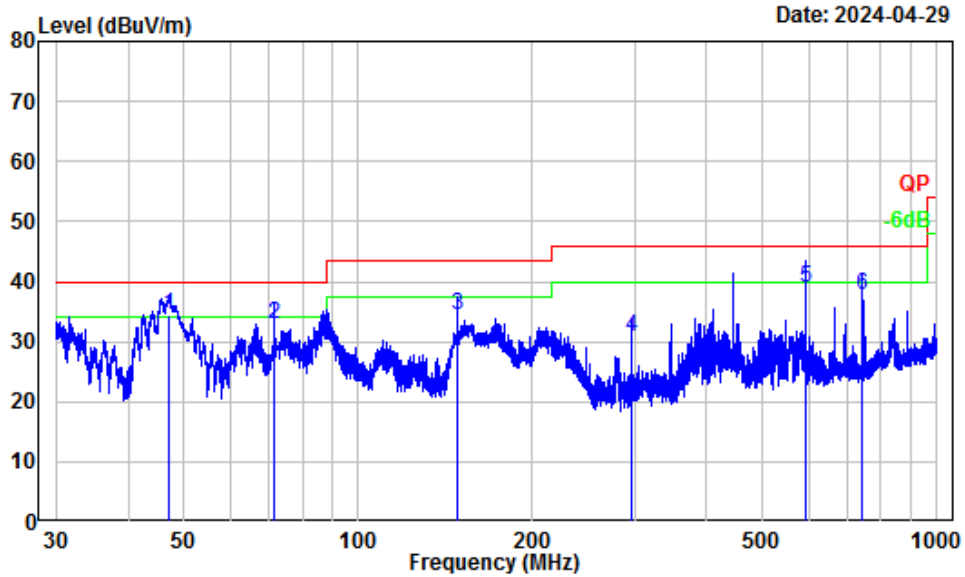

Site : Chamber A  
 Condition : 3m Vertical  
 Project Number: 2401S52962-RF  
 Note : BT  
 Tester : Anson Su

	Freq	Factor	Read Level	Level	Limit Line	Over Limit	Remark
	MHz	dB/m	dBuV	dBuV/m	dBuV/m	dB	
1	46.91	-15.78	50.20	34.42	40.00	-5.58	QP
2	71.58	-17.29	50.11	32.82	40.00	-7.18	QP
3	148.51	-11.60	46.00	34.40	43.50	-9.10	QP
4	296.96	-10.48	41.35	30.87	46.00	-15.13	QP
5	594.09	-4.50	43.59	39.09	46.00	-6.91	QP
6	742.58	-2.13	40.00	37.87	46.00	-8.13	QP

**Above 1GHz:**

Frequency (MHz)	Receiver		Polar (H/V)	Factor (dB/m)	Corrected Amplitude (dBµV/m)	Limit (dBµV/m)	Margin (dB)
	Reading (dBµV)	PK/Ave					
<b>GFSK</b>							
Low Channel 2402MHz							
2317.58	55.13	PK	H	-3.03	52.10	74	-21.90
2386.93	55.49	PK	V	-2.93	52.56	74	-21.44
4804.00	45.98	PK	H	2.42	48.40	74	-25.60
4804.00	46.37	PK	V	2.42	48.79	74	-25.21
Middle Channel 2441MHz							
4882.00	46.05	PK	H	2.58	48.63	74	-25.37
4882.00	46.21	PK	V	2.58	48.79	74	-25.21
High Channel 2480MHz							
2484.15	61.70	PK	H	-3.17	58.53	74	-15.47
2483.53	56.32	PK	V	-3.17	53.15	74	-20.85
4960.00	46.26	PK	H	2.68	48.94	74	-25.06
4960.00	46.05	PK	V	2.68	48.73	74	-25.27

**Note:**

Factor = Antenna factor (RX) + Cable Loss – Amplifier Factor

Corrected Amplitude = Factor + Reading

Margin = Corrected. Amplitude - Limit

The other spurious emission which is in the noise floor level was not recorded.

Field Strength of Average							
Frequency (MHz)	Peak Measurement @3m (dBµV/m)	Polar (H/V)	Duty Cycle Corrected Factor (dB)	Average Level (dBµV/m)	FCC Part 15.247/RSS-247		
					Limit (dBµV/m)	Margin (dB)	Comment
<b>Low Channel 2402MHz</b>							
2317.58	52.10	H	-24.73	27.37	54	-26.63	Bandedge
2386.93	52.56	V	-24.73	27.83	54	-26.17	Bandedge
4804.00	48.40	H	-24.73	23.67	54	-30.33	Harmonic
4804.00	48.79	V	-24.73	24.06	54	-29.94	Harmonic
<b>Middle Channel 2441MHz</b>							
4882.00	48.63	H	-24.73	23.9	54	-30.10	Harmonic
4882.00	48.79	V	-24.73	24.06	54	-29.94	Harmonic
<b>High Channel 2480MHz</b>							
2484.15	58.53	H	-24.73	33.8	54	-20.2	Bandedge
2483.53	53.15	V	-24.73	28.42	54	-25.58	Bandedge
4960.00	48.94	H	-24.73	24.21	54	-29.79	Harmonic
4960.00	48.73	V	-24.73	24	54	-30.00	Harmonic

Note: Average level= Peak level+ Duty Cycle Corrected Factor

Worst case duty cycle:

$$\text{Duty cycle} = \text{Ton}/100\text{ms} = 2.899 \times 2 / 100 = 0.05798$$

$$\text{Duty Cycle Corrected Factor} = 20\lg(\text{Duty cycle}) = 20\lg 0.0575 = -24.73$$

**Duty Cycle  
(100ms)**

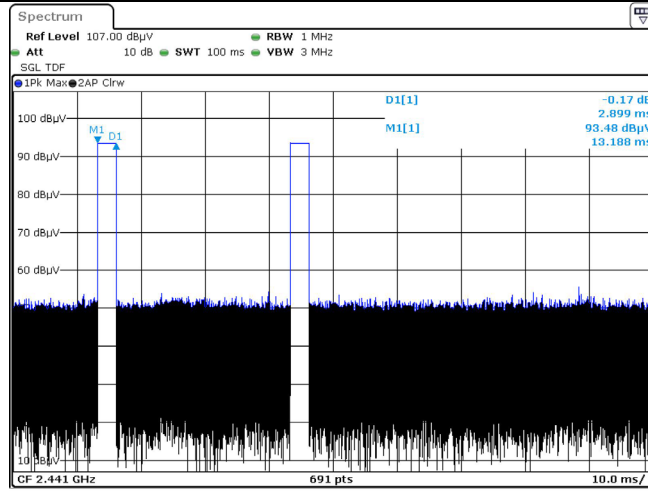

ProjectNo.:2401S52962-RF Tester:Tyler Wu  
Date: 25.APR.2024 21:53:38

**Duty Cycle  
(1s)**

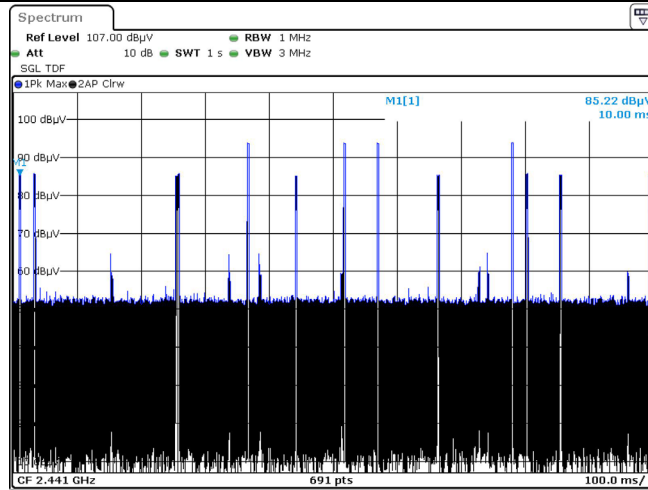

ProjectNo.:2401S52962-RF Tester:Tyler Wu  
Date: 25.APR.2024 21:52:18



Test plots for example as below:

**Band Edge Measurements (Radiated):**

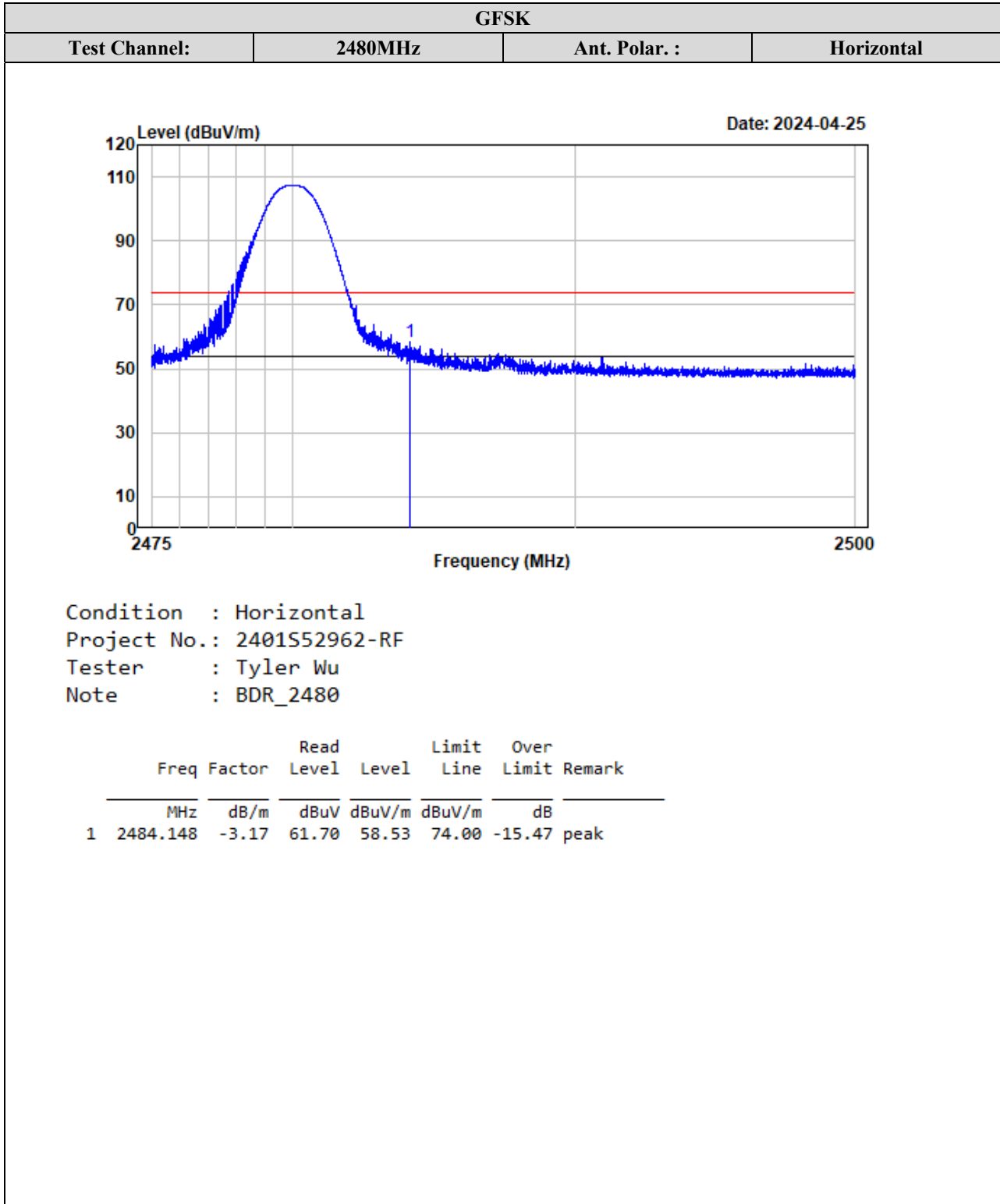

GFSK			
Test Channel:	2480MHz	Ant. Polar. :	Vertical

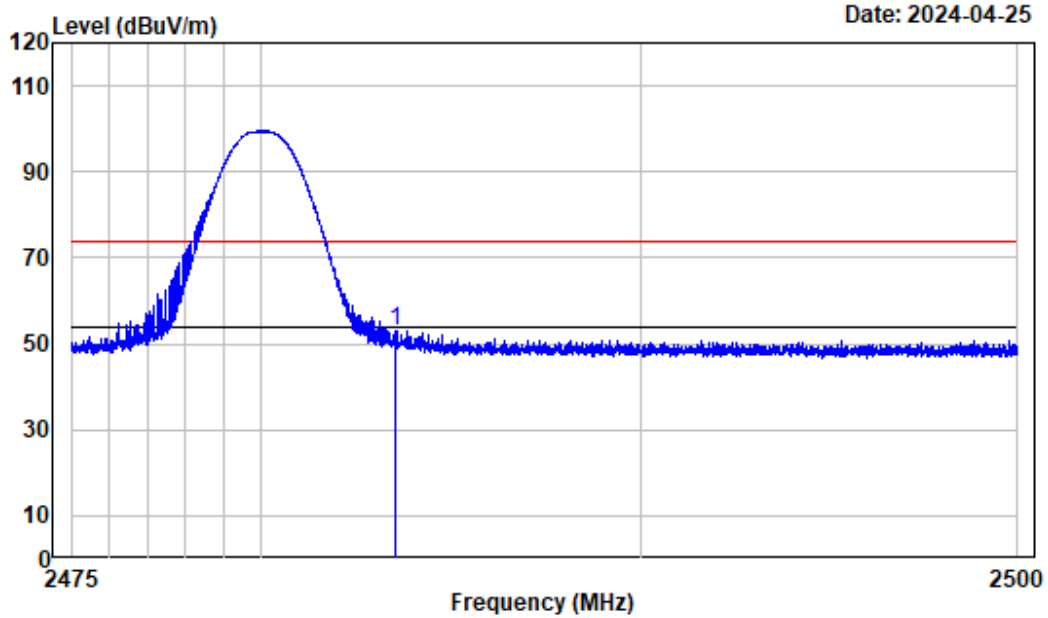

Condition : Vertical  
 Project No.: 2401S52962-RF  
 Tester : Tyler Wu  
 Note : BDR\_2480

	Freq	Factor	Read Level	Level	Limit Line	Over Limit	Remark
	MHz	dB/m	dBuV	dBuV/m	dBuV/m	dB	
1	2483.530	-3.17	56.32	53.15	74.00	-20.85	peak

**Harmonic Measurements:**

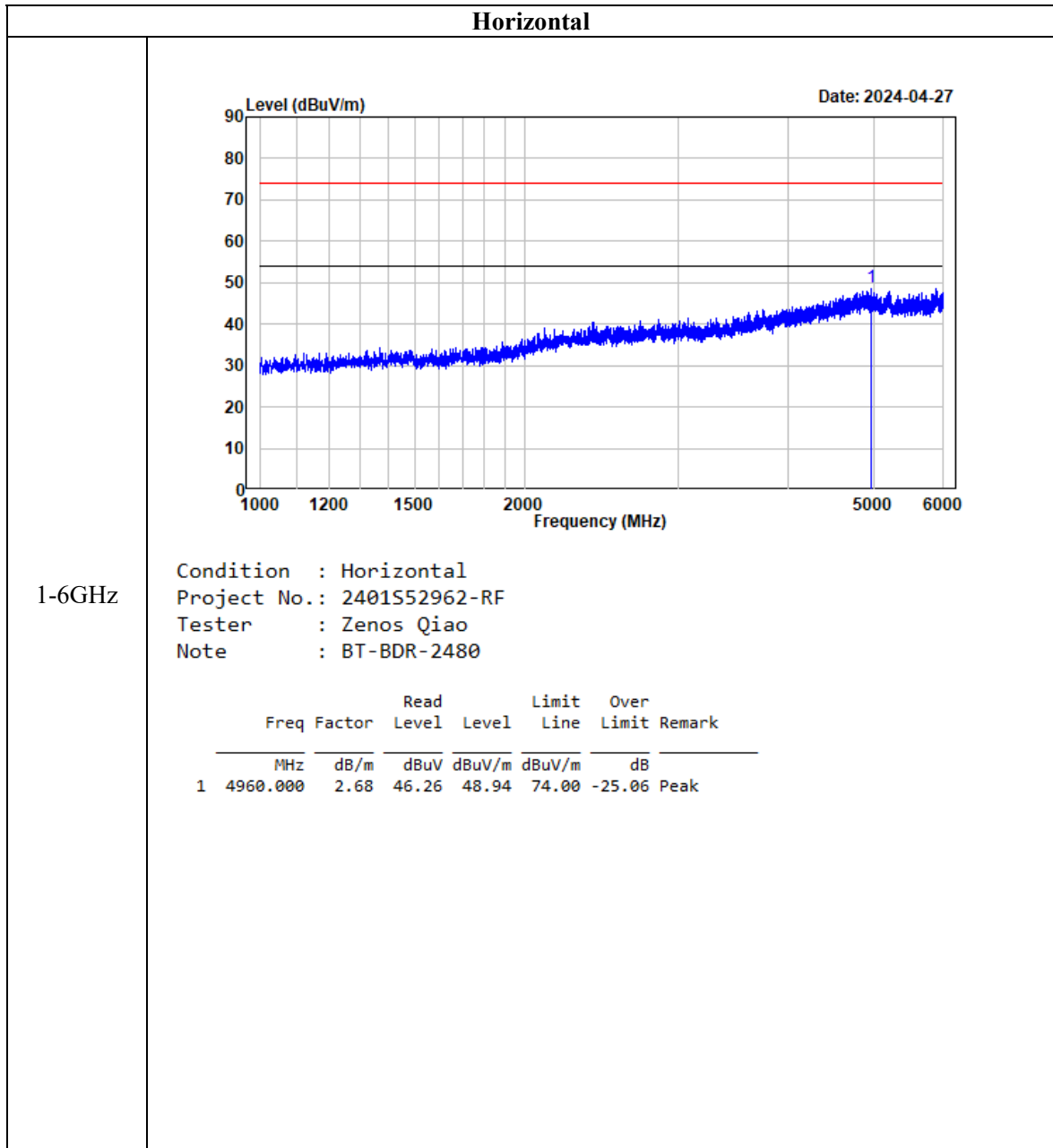

**Vertical**

1-6GHz

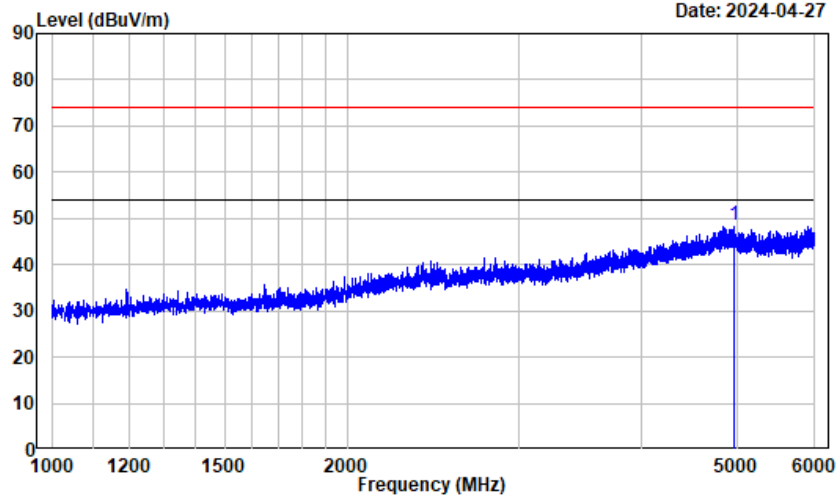

Condition : Vertical  
 Project No.: 2401S52962-RF  
 Tester : Zenos Qiao  
 Note : BT-BDR-2480

	Freq	Factor	Read Level	Level	Limit Line	Over Limit	Remark
	MHz	dB/m	dBuV	dBuV/m	dBuV/m	dB	
1	4960.000	2.68	46.05	48.73	74.00	-25.27	Peak

**Horizontal**

6-18GHz

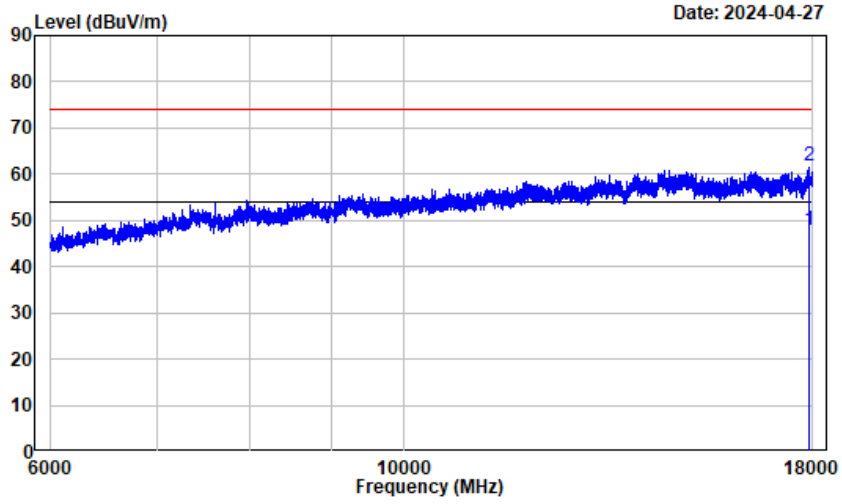

Condition : Horizontal  
 Project No.: 2401S52962-RF  
 Tester : Zenos Qiao  
 Note : BT-BDR-2480

	Freq	Factor	Read Level	Level	Limit Line	Over Limit	Remark
	MHz	dB/m	dBuV	dBuV/m	dBuV/m	dB	
1	17919.000	24.05	23.81	47.86	54.00	-6.14	Average
2	17919.000	24.05	37.68	61.73	74.00	-12.27	Peak

**Vertical**

6-18GHz

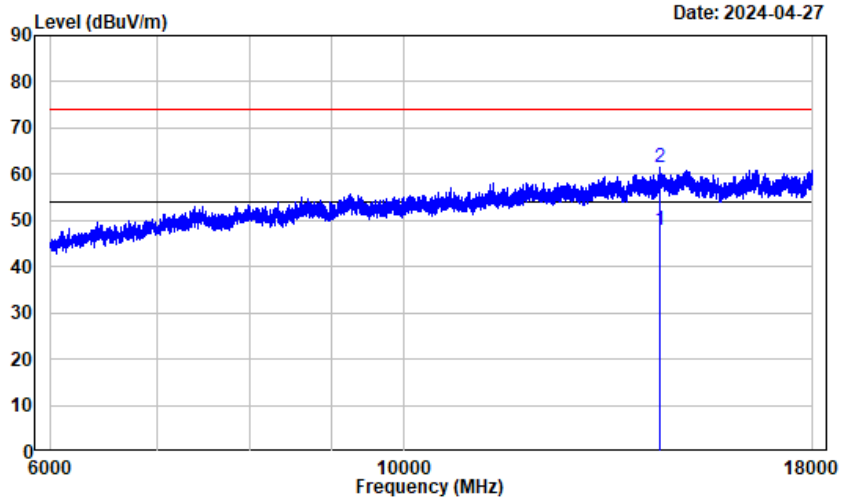

Condition : Vertical  
 Project No.: 2401S52962-RF  
 Tester : Zenos Qiao  
 Note : BT-BDR-2480

	Freq	Factor	Read Level	Level	Limit Line	Over Limit	Remark
	MHz	dB/m	dBuV	dBuV/m	dBuV/m	dB	
1	14455.500	17.37	30.35	47.72	54.00	-6.28	Average
2	14455.500	17.37	44.19	61.56	74.00	-12.44	Peak

**Horizontal**

18-25GHz

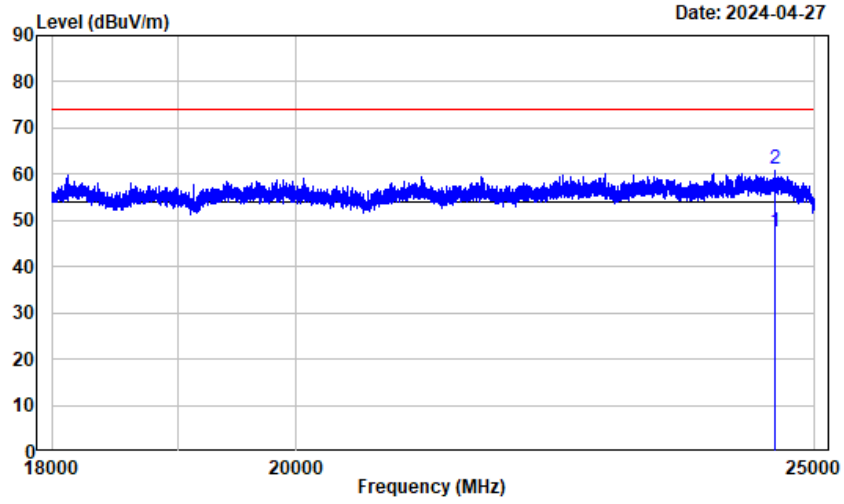

Condition : Horizontal  
 Project No.: 2401S52962-RF  
 Tester : Zenos Qiao  
 Note : BT-BDR-2480

	Freq	Factor	Read Level	Level	Limit Line	Over Limit	Remark
	MHz	dB/m	dBuV	dBuV/m	dBuV/m	dB	
1	24575.630	18.90	28.67	47.57	54.00	-6.43	Average
2	24575.630	18.90	42.28	61.18	74.00	-12.82	Peak

**Vertical**

18-25GHz

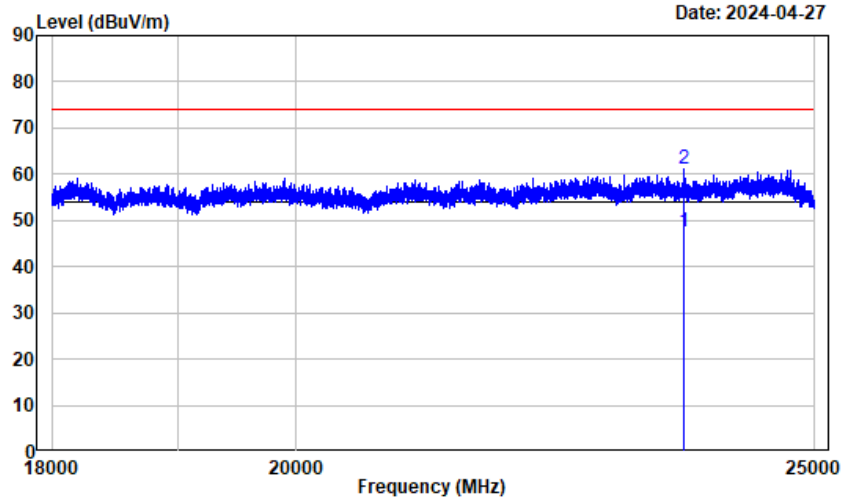

Condition : Vertical  
 Project No.: 2401S52962-RF  
 Tester : Zenos Qiao  
 Note : BT-BDR-2480

	Freq	Factor	Read Level	Level	Limit Line	Over Limit	Remark
	MHz	dB/m	dBuV	dBuV/m	dBuV/m	dB	
1	23629.750	17.54	29.91	47.45	54.00	-6.55	Average
2	23629.750	17.54	43.46	61.00	74.00	-13.00	Peak



## **FCC §15.247(a) (1) & RSS-247 § 5.1 (b) - CHANNEL SEPARATION TEST**

### **Applicable Standard**

According to FCC §15.247(a) (1):

Frequency hopping systems shall have hopping channel carrier frequencies separated by a minimum of 25 kHz or the 20 dB bandwidth of the hopping channel, whichever is greater. Alternatively, frequency hopping systems operating in the 2400-2483.5 MHz band may have hopping channel carrier frequencies that are separated by 25 kHz or two-thirds of the 20 dB bandwidth of the hopping channel, whichever is greater provided the systems operate with an output power no greater than 125 mW. The system shall hop to channel frequencies that are selected at the system hopping rate from a pseudo randomly ordered list of hopping frequencies. Each frequency must be used equally on the average by each transmitter. The system receivers shall have input bandwidths that match the hopping channel bandwidths of their corresponding transmitters and shall shift frequencies in synchronization with the transmitted signals.

According to RSS-247 § 5.1 (b):

Frequency hopping systems (FHSs) shall have hopping channel carrier frequencies separated by a minimum of 25 kHz or the -20 dB bandwidth of the hopping channel, whichever is greater. Alternatively, FHSs operating in the band 2400-2483.5 MHz may have hopping channel carrier frequencies that are separated by 25 kHz or two thirds of the -20 dB bandwidth of the hopping channel, whichever is greater, provided that the systems operate with an output power no greater than 0.125 W. The system receivers shall have input bandwidths that match the hopping channel bandwidths of their corresponding transmitters and shall shift frequencies in synchronization with the transmitted signals.

### **Test Procedure**

Test Method: ANSI C63.10-2013 Clause 7.8.2

1. Set the EUT in transmitting mode, max hold the channel.
2. Set the adjacent channel of the EUT and max hold another trace.
3. Measure the channel separation.

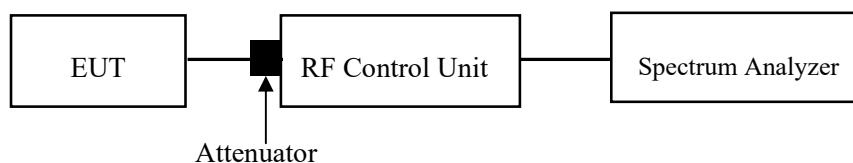

**Test Data****Environmental Conditions**

<b>Temperature:</b>	22~24 °C
<b>Relative Humidity:</b>	48~52 %
<b>ATM Pressure:</b>	101 kPa

*The testing was performed by Lee Li on 2024-04-25 and 2024-05-15.*

*EUT operation mode: Transmitting*

***Test Result: Compliant. Please refer to the Appendix.***

## **FCC §15.247(a) (1) & RSS-247 § 5.1 (a), RSS-GEN § 6.7 - 20 dB EMISSION BANDWIDTH & 99% OCCUPIED BANDWIDTH**

### **Applicable Standard**

According to FCC §15.247(a) (1):

Alternatively, frequency hopping systems operating in the 2400–2483.5 MHz band may have hopping channel carrier frequencies that are separated by 25 kHz or two-thirds of the 20 dB bandwidth of the hopping channel, whichever is greater, provided the systems operate with an output power no greater than 125 mW.

According to RSS-247 § 5.1 (a), RSS-GEN § 6.7:

The occupied bandwidth or the “99% emission bandwidth” is defined as the frequency range between two points, one above and the other below the carrier frequency, within which 99% of the total transmitted power of the fundamental transmitted emission is contained. The occupied bandwidth shall be reported for all equipment in addition to the specified bandwidth required in the applicable RSSs.

In some cases, the “20 dB bandwidth” is required, which is defined as the frequency range between two points, one at the lowest frequency below and one at the highest frequency above the carrier frequency, at which the maximum power level of the transmitted emission is attenuated 20 dB below the maximum in-band power level of the modulated signal, where the two points are on the outskirts of the in-band emission.

### **Test Procedure**

Test Method: ANSI C63.10-2013 Clause 7.8.7 & Clause 6.9.2

The following conditions shall be observed for measuring the occupied bandwidth and 20 dB bandwidth:

- The transmitter shall be operated at its maximum carrier power measured under normal test conditions.
- The span of the spectrum analyzer shall be set large enough to capture all products of the modulation process, including the emission skirts, around the carrier frequency, but small enough to avoid having other emissions (e.g. on adjacent channels) within the span.
- The detector of the spectrum analyzer shall be set to “Sample”. However, a peak, or peak hold, may be used in place of the sampling detector since this usually produces a wider bandwidth than the actual bandwidth (worst-case measurement). Use of a peak hold (or “Max Hold”) may be necessary to determine the occupied / 20 dB bandwidth if the device is not transmitting continuously.
- The resolution bandwidth (RBW) shall be in the range of 1% to 5% of the actual occupied / 20 dB bandwidth and the video bandwidth (VBW) shall not be smaller than three times the RBW value. Video averaging is not permitted.

Note: It may be necessary to repeat the measurement a few times until the RBW and VBW are in compliance with the above requirement.

For the 99% emission bandwidth, the trace data points are recovered and directly summed in linear power level terms. The recovered amplitude data points, beginning at the lowest frequency, are placed in a running sum until 0.5% of the total is reached, and that frequency recorded. The process is repeated for the highest frequency data points (starting at the highest frequency, at the right side of the span, and going down in frequency). This frequency is then recorded. The difference between the two recorded frequencies is the occupied bandwidth (or the 99% emission bandwidth).

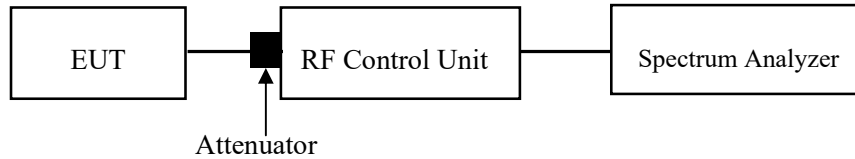

**Test Data**

**Environmental Conditions**

<b>Temperature:</b>	24 °C
<b>Relative Humidity:</b>	48 %
<b>ATM Pressure:</b>	101 kPa

*The testing was performed by Lee Li on 2024-04-25.*

*EUT operation mode: Transmitting*

***Test Result: Compliant. Please refer to the Appendix.***

## FCC §15.247(a) (1) (iii) & RSS-247 § 5.1 (d) - QUANTITY OF HOPPING CHANNEL TEST

### Applicable Standard

According to FCC §15.247(a) (1) (iii):

Frequency hopping systems in the 2400–2483.5 MHz band shall use at least 15 channels. The average time of occupancy on any channel shall not be greater than 0.4 seconds within a period of 0.4 seconds multiplied by the number of hopping channels employed. Frequency hopping systems may avoid or suppress transmissions on a particular hopping frequency provided that a minimum of 15 channels are used.

According to RSS-247 § 5.1 (d):

Frequency hopping systems (FHSS) operating in the band 2400-2483.5 MHz shall use at least 15 hopping channels. The average time of occupancy on any channel shall not be greater than 0.4 seconds within a period of 0.4 seconds, multiplied by the number of hopping channels employed. Transmissions on particular hopping frequencies may be avoided or suppressed provided that at least 15 hopping channels are used.

### Test Procedure

Test Method: ANSI C63.10-2013 Clause 7.8.3

1. Check the calibration of the measuring instrument (SA) using either an internal calibrator or a known signal from an external generator.
2. Set the EUT in hopping mode from first channel to last.
3. By using the max-hold function record the quantity of the channel.

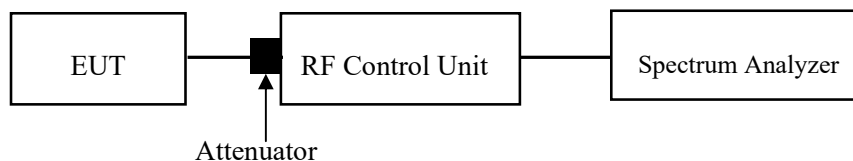

**Test Data****Environmental Conditions**

<b>Temperature:</b>	24 °C
<b>Relative Humidity:</b>	48 %
<b>ATM Pressure:</b>	101 kPa

*The testing was performed by Lee Li on 2024-04-25.*

*EUT operation mode: Transmitting*

***Test Result: Compliant. Please refer to the Appendix.***

## FCC §15.247(a) (1) (iii) & RSS-247 § 5.1 (d) - TIME OF OCCUPANCY (DWELL TIME)

### Applicable Standard

According to FCC §15.247(a) (1) (iii):

Frequency hopping systems in the 2400-2483.5 MHz shall use at least 15 channels. The average time of occupancy on any channel shall not be greater than 0.4 seconds within a period of 0.4 seconds multiplied by the number of hopping channels employed. Frequency hopping systems may avoid or suppress transmissions on a particular hopping frequency provided that a minimum of 15 channels are used.

According to RSS-247 § 5.1 (d):

Frequency hopping systems (FHSs) operating in the band 2400-2483.5 MHz shall use at least 15 hopping channels. The average time of occupancy on any channel shall not be greater than 0.4 seconds within a period of 0.4 seconds, multiplied by the number of hopping channels employed. Transmissions on particular hopping frequencies may be avoided or suppressed provided that at least 15 hopping channels are used.

### Test Procedure

Test Method: ANSI C63.10-2013 Clause 7.8.4

1. The EUT was worked in channel hopping.
2. Set the RBW to: 1MHz.
3. Set the VBW  $\geq 3 \times$  RBW.
4. Set the span to 0Hz.
5. Detector = peak.
6. Sweep time = auto couple.
7. Trace mode = max hold.
8. Allow trace to fully stabilize.
9. Recorded the time of single pulses

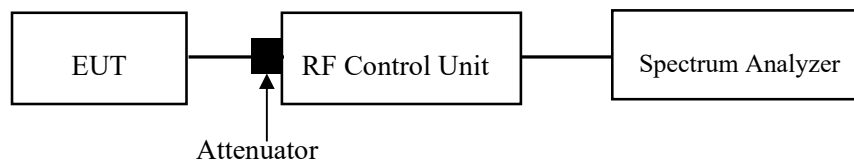

Note 1: A period time= $0.4 \times 79 = 31.6(S)$ , Result=BurstWidth\*Totalhops

Note 2: Totalhops=Hopping Number in  $3.16s \times 10$

Note 3: Hopping Number in  $3.16s =$  Total of highest signals in  $3.16s$  (Second high signals were other channel)

**Test Data****Environmental Conditions**

<b>Temperature:</b>	24 °C
<b>Relative Humidity:</b>	48 %
<b>ATM Pressure:</b>	101 kPa

*The testing was performed by Lee Li on 2024-04-25.*

*EUT operation mode: Transmitting*

***Test Result: Compliant. Please refer to the Appendix.***



## FCC §15.247(b) (1) & RSS-247§ 5.1(b) &§ 5.4(b) - PEAK OUTPUT POWER MEASUREMENT

### Applicable Standard

According to FCC §15.247(b) (1):

For frequency hopping systems operating in the 2400–2483.5 MHz band employing at least 75 non-overlapping hopping channels, and all frequency hopping systems in the 5725-5850 MHz band: 1 watt. And for all other frequency hopping systems in the 2400–2483.5 MHz band: 0.125 watts.

According to RSS-247§ 5.1(b) &§ 5.4(b):

For frequency hopping systems (FHSs) operating in the band 2400-2483.5 MHz, the maximum peak conducted output power shall not exceed 1.0 W if the hopset uses 75 or more hopping channels; the maximum peak conducted output power shall not exceed 0.125 W if the hopset uses less than 75 hopping channels. The e.i.r.p. shall not exceed 4 W (see Section 5.4(e) for exceptions).

Frequency hopping systems (FHSs) shall have hopping channel carrier frequencies separated by a minimum of 25 kHz or the -20 dB bandwidth of the hopping channel, whichever is greater. Alternatively, FHSs operating in the band 2400-2483.5 MHz may have hopping channel carrier frequencies that are separated by 25 kHz or two thirds of the -20 dB bandwidth of the hopping channel, whichever is greater, provided that the systems operate with an output power no greater than 0.125 W.

### Test Procedure

Test Method: ANSI C63.10-2013 Clause 7.8.5

1. Place the EUT on a bench and set in transmitting mode.
2. Remove the antenna from the EUT and then connect a low loss RF cable from the antenna port to one test equipment.
3. Add a correction factor to the display.

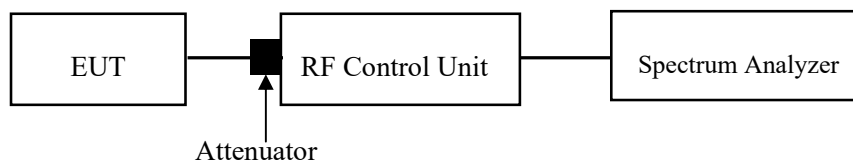

**Test Data****Environmental Conditions**

<b>Temperature:</b>	24 °C
<b>Relative Humidity:</b>	48 %
<b>ATM Pressure:</b>	101 kPa

*The testing was performed by Lee Li on 2024-04-25.*

*EUT operation mode: Transmitting*

***Test Result: Compliant. Please refer to the Appendix.***

## **FCC §15.247(d) & RSS-247 § 5.5 - BAND EDGES TESTING**

### **Applicable Standard**

According to FCC §15.247(d).

In any 100 kHz bandwidth outside the frequency band in which the spread spectrum or digitally modulated intentional radiator is operating, the radio frequency power that is produced by the intentional radiator shall be at least 20 dB below that in the 100 kHz bandwidth within the band that contains the highest level of the desired power, based on either an RF conducted or a radiated measurement, provided the transmitter demonstrates compliance with the peak conducted power limits. If the transmitter complies with the conducted power limits based on the use of RMS averaging over a time interval, as permitted under paragraph (b)(3) of this section, the attenuation required under this paragraph shall be 30 dB instead of 20 dB. Attenuation below the general limits specified in §15.209(a) is not required. In addition, radiated emissions which fall in the restricted bands, as defined in §15.205(a), must also comply with the radiated emission limits specified in §15.209(a) (see §15.205(c)).

According to RSS-247 § 5.5.

In any 100 kHz bandwidth outside the frequency band in which the spread spectrum or digitally modulated device is operating, the RF power that is produced shall be at least 20 dB below that in the 100 kHz bandwidth within the band that contains the highest level of the desired power, based on either an RF conducted or a radiated measurement, provided that the transmitter demonstrates compliance with the peak conducted power limits. If the transmitter complies with the conducted power limits based on the use of root-mean-square averaging over a time interval, as permitted under Section 5.4(e), the attenuation required shall be 30 dB instead of 20 dB. Attenuation below the general field strength limits specified in RSS-Gen is not required.

### **Test Procedure**

Test Method: ANSI C63.10-2013 Clause 7.8.6 & Clause 6.10

1. Check the calibration of the measuring instrument using either an internal calibrator or a known signal from an external generator.
2. Remove the antenna from the EUT and then connect to a low loss RF cable from the antenna port to a EMI test receiver, then turn on the EUT and make it operate in transmitting mode. Then set it to Low Channel and High Channel within its operating range, and make sure the instrument is operated in its linear range.
3. Set RBW of spectrum analyzer to 100 kHz with a convenient frequency span including 100 kHz bandwidth from band edge.
4. Measure the highest amplitude appearing on spectral display and set it as a reference level. Plot the graph with marking the highest point and edge frequency.
5. Repeat above procedures until all measured frequencies were complete.

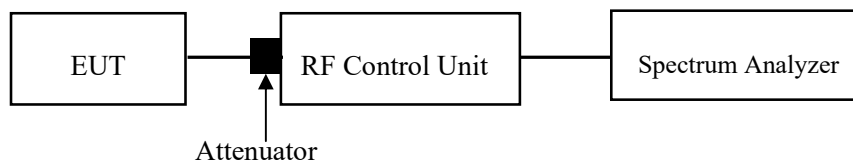

**Test Data****Environmental Conditions**

<b>Temperature:</b>	22~24 °C
<b>Relative Humidity:</b>	48~52 %
<b>ATM Pressure:</b>	101 kPa

*The testing was performed by Lee Li on 2024-04-25 and Tom Tan on 2024-05-15.*

*EUT operation mode: Transmitting*

***Test Result: Compliant. Please refer to the Appendix.***

## **EUT PHOTOGRAPHS**

---

Please refer to the attachment 2401S52962-RF External photo and 2401S52962-RF Internal photo.

## **TEST SETUP PHOTOGRAPHS**

---

Please refer to the attachment 2401S52962-RFA Test Setup photo.

**APPENDIX****Appendix A: 20dB Emission Bandwidth****Test Result**

Test Mode	Antenna	Frequency[MHz]	20db EBW[MHz]	FL[MHz]	FH[MHz]	Limit[MHz]	Verdict
DH1	Ant1	2402	0.89	2401.55	2402.44	---	---
		2441	0.89	2440.55	2441.44	---	---
		2480	0.89	2479.54	2480.44	---	---
2DH1	Ant1	2402	1.43	2401.27	2402.69	---	---
		2441	1.43	2440.27	2441.70	---	---
		2480	1.43	2479.26	2480.70	---	---
3DH1	Ant1	2402	1.44	2401.27	2402.71	---	---
		2441	1.44	2440.27	2441.71	---	---
		2480	1.44	2479.27	2480.71	---	---

### Test Graphs

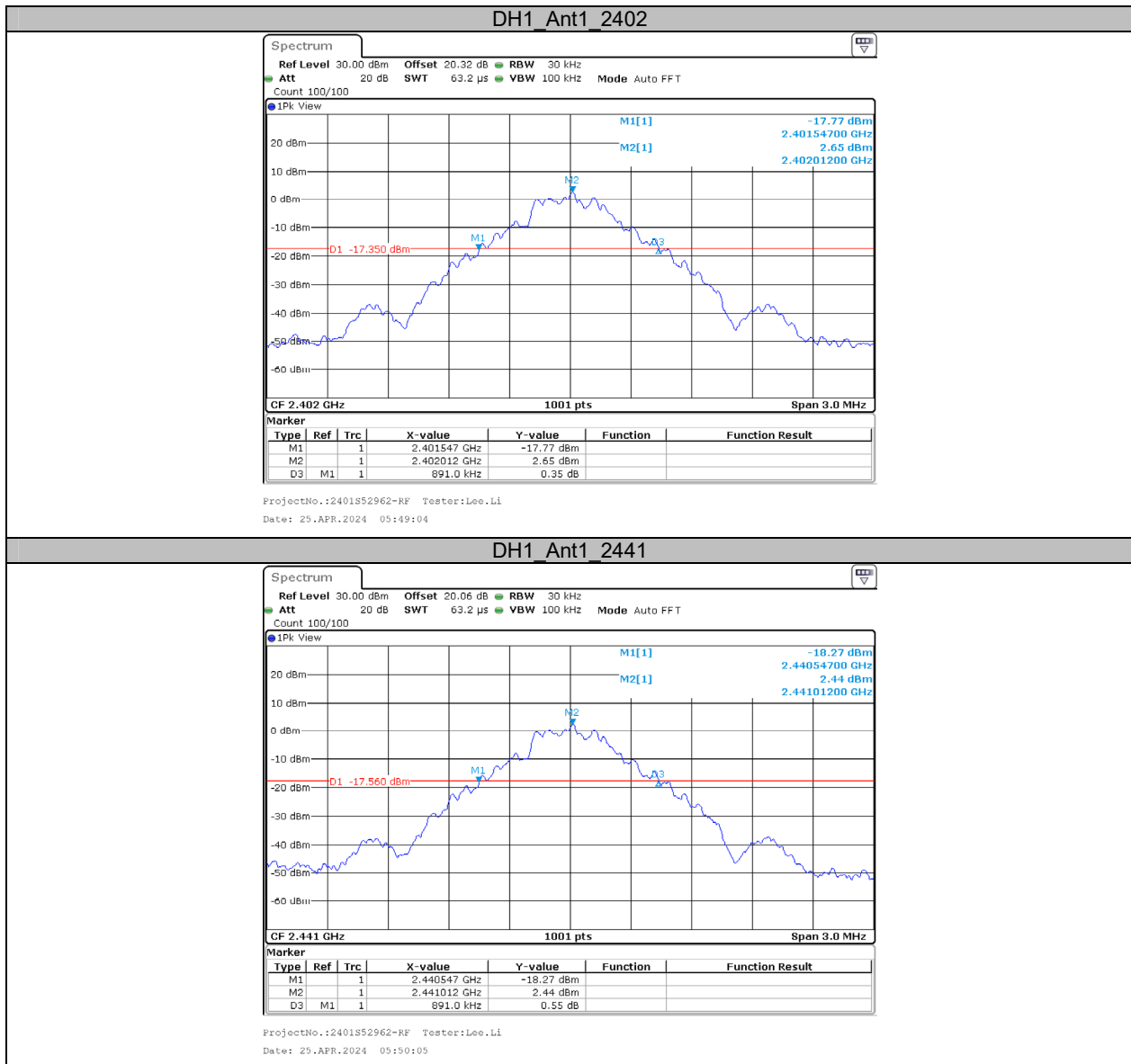



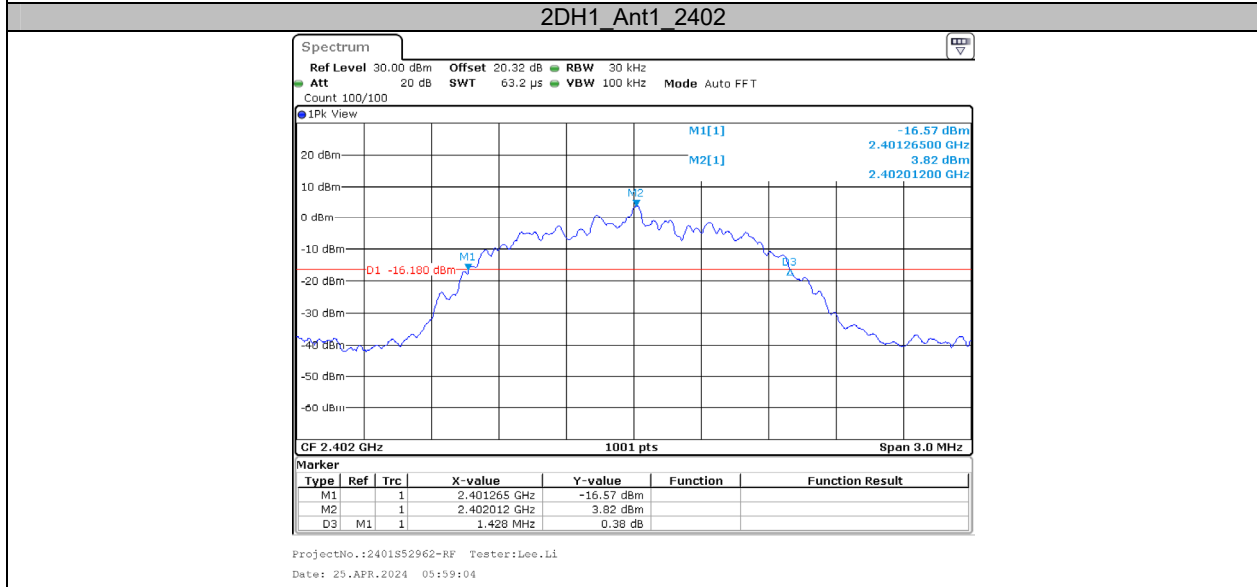
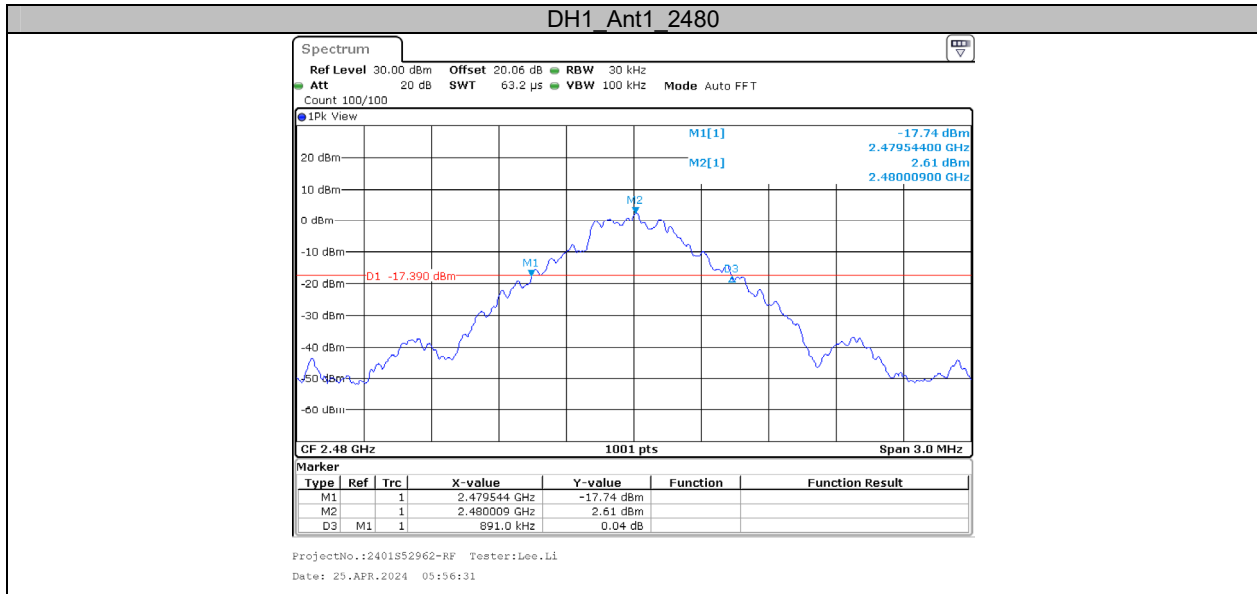

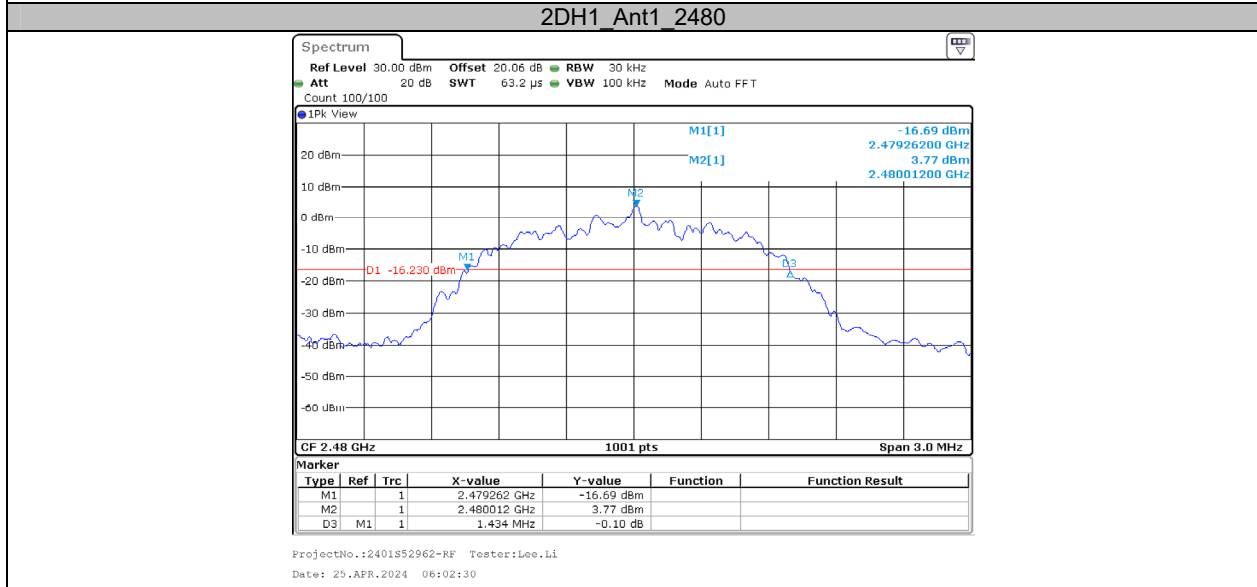
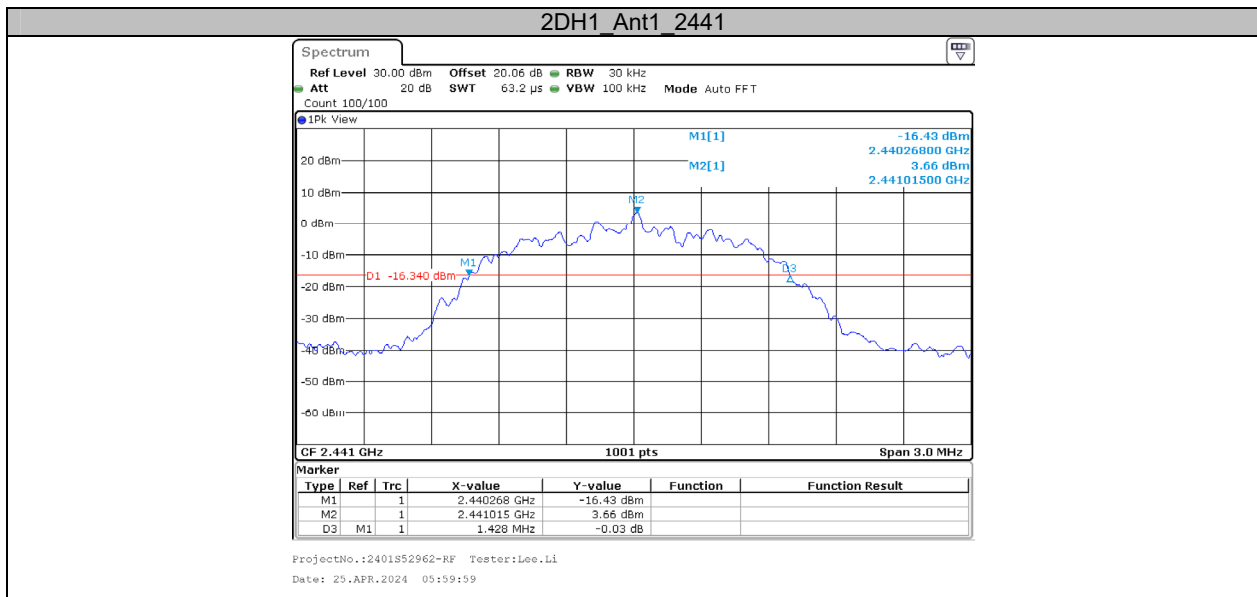

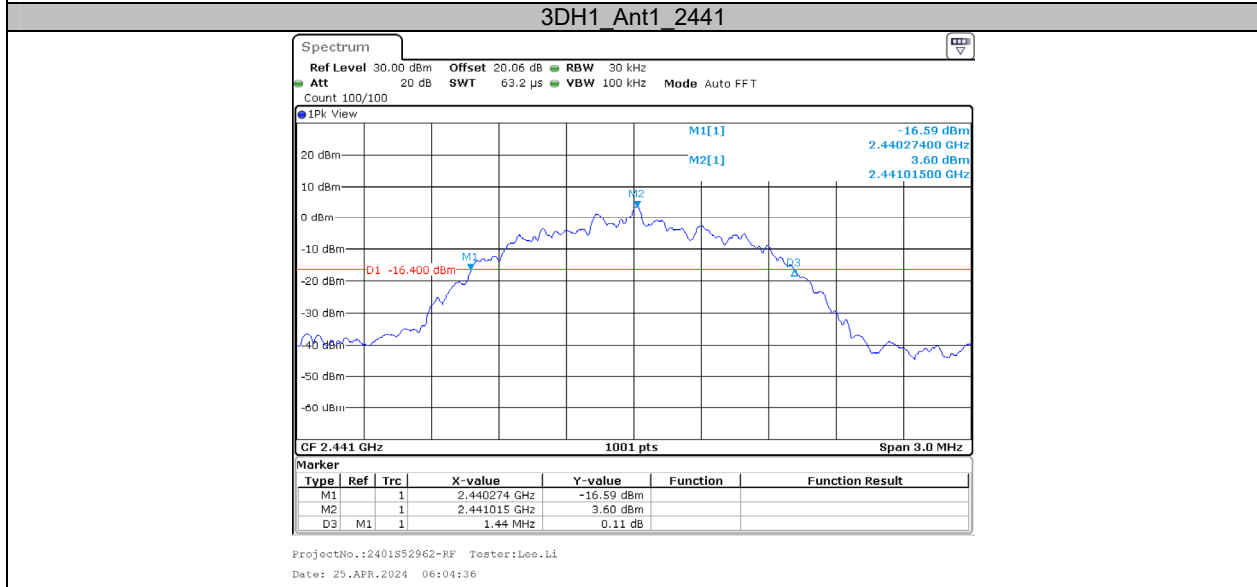
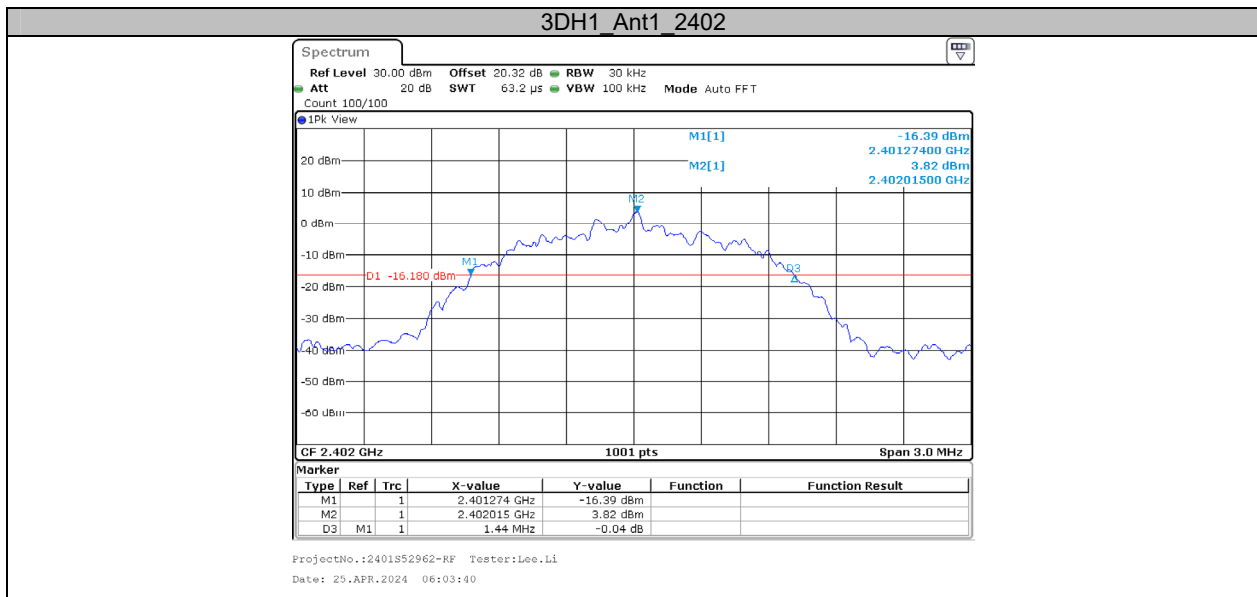

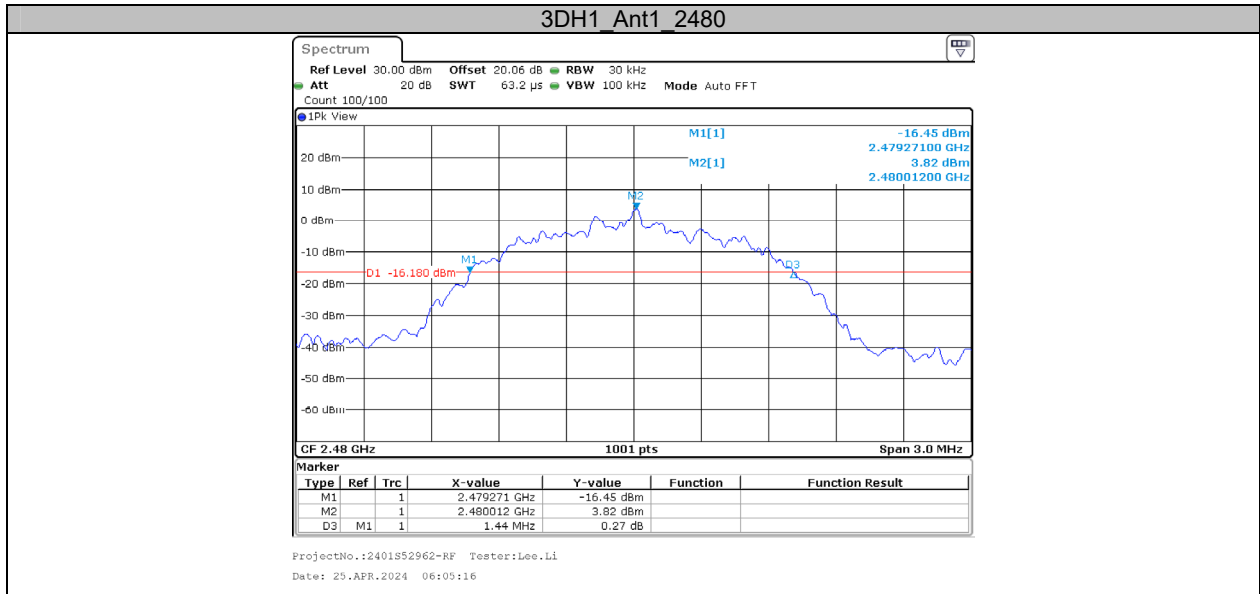

**Appendix B: Occupied Channel Bandwidth****Test Result**

Test Mode	Antenna	Frequency[MHz]	OCB [MHz]	FL[MHz]	FH[MHz]	Limit[MHz]	Verdict
DH1	Ant1	2402	0.860	2401.5684	2402.4286	---	---
		2441	0.854	2440.5714	2441.4256	---	---
		2480	0.854	2479.5684	2480.4226	---	---
2DH1	Ant1	2402	1.343	2401.3197	2402.6623	---	---
		2441	1.346	2440.3197	2441.6653	---	---
		2480	1.346	2479.3167	2480.6623	---	---
3DH1	Ant1	2402	1.352	2401.3167	2402.6683	---	---
		2441	1.349	2440.3197	2441.6683	---	---
		2480	1.349	2479.3167	2480.6653	---	---

### Test Graphs

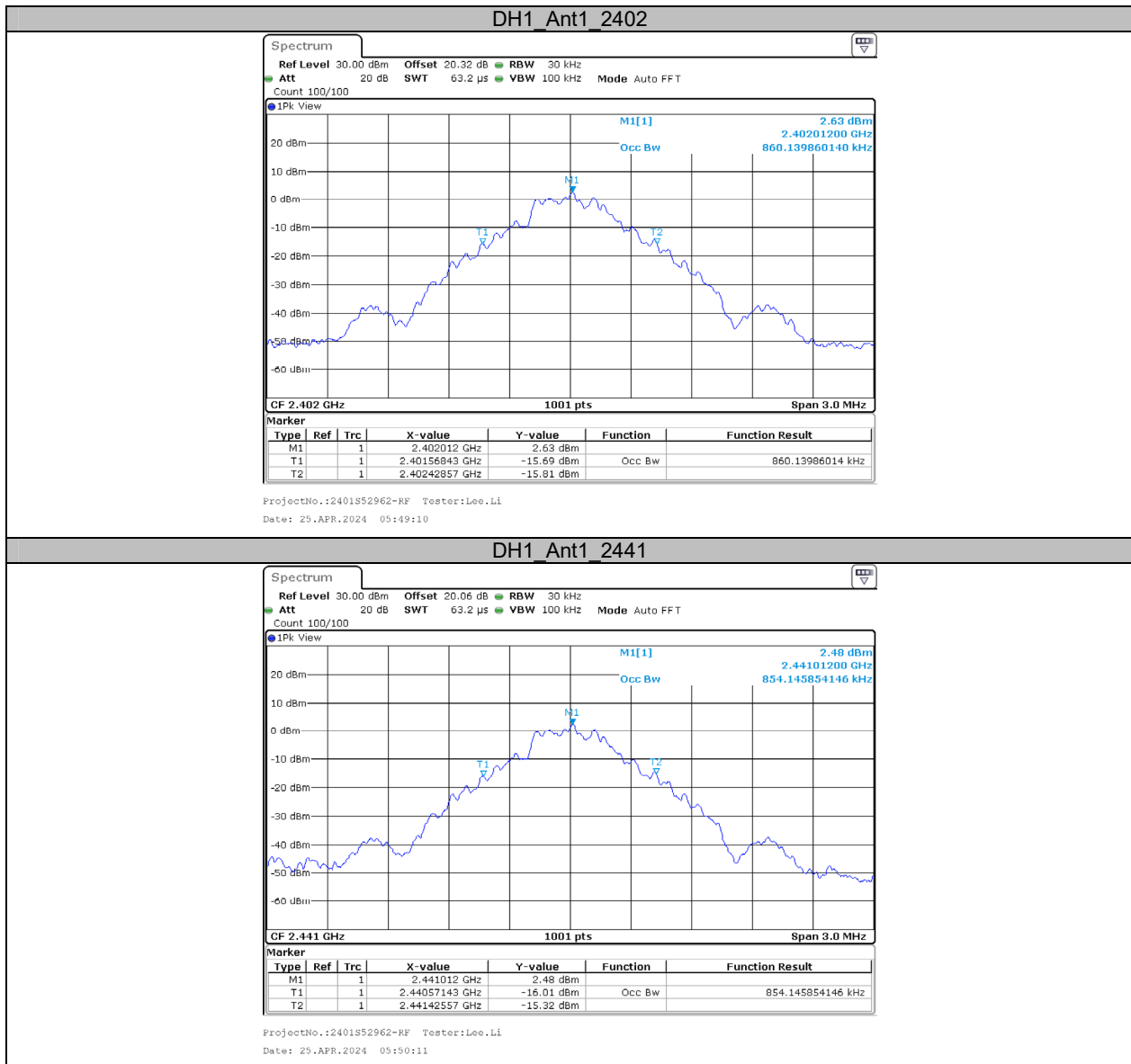

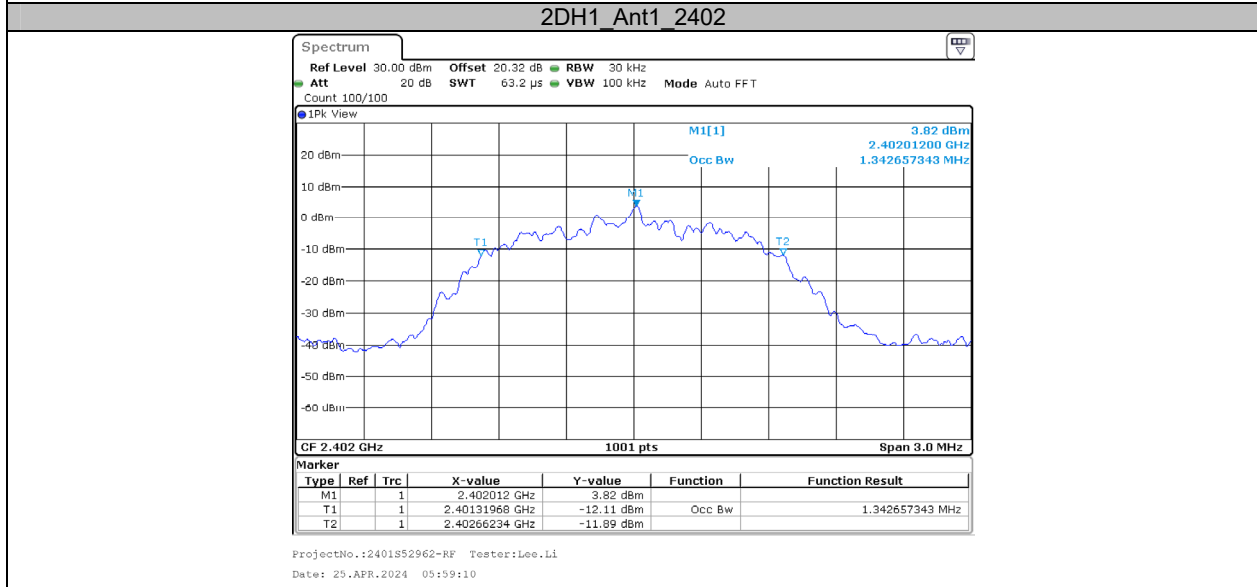
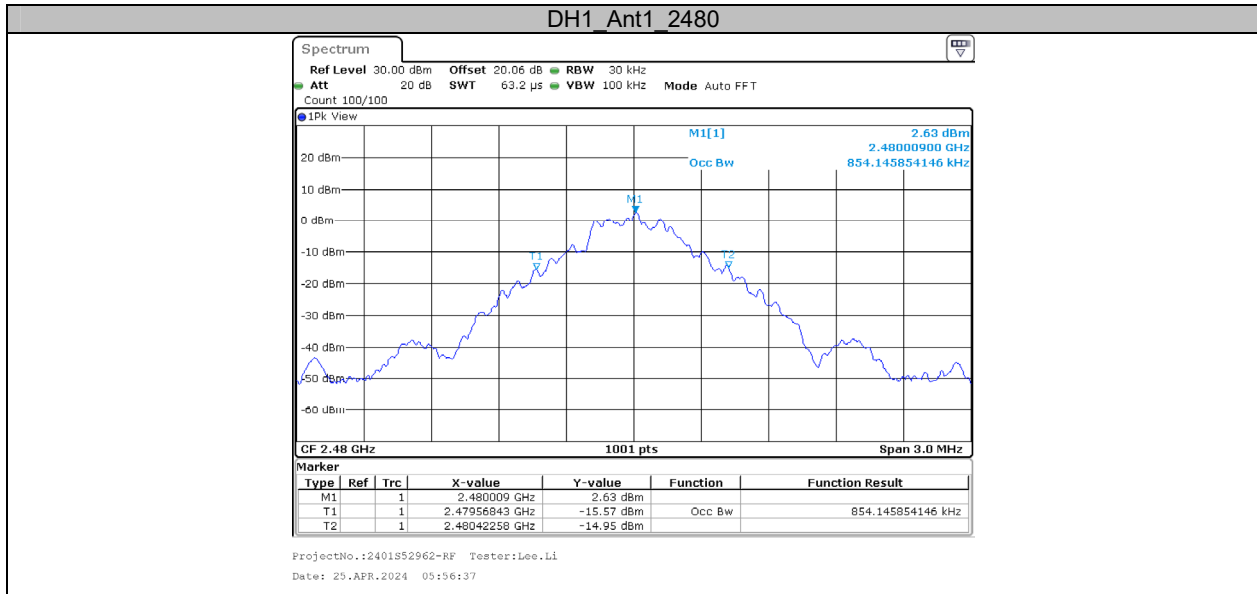

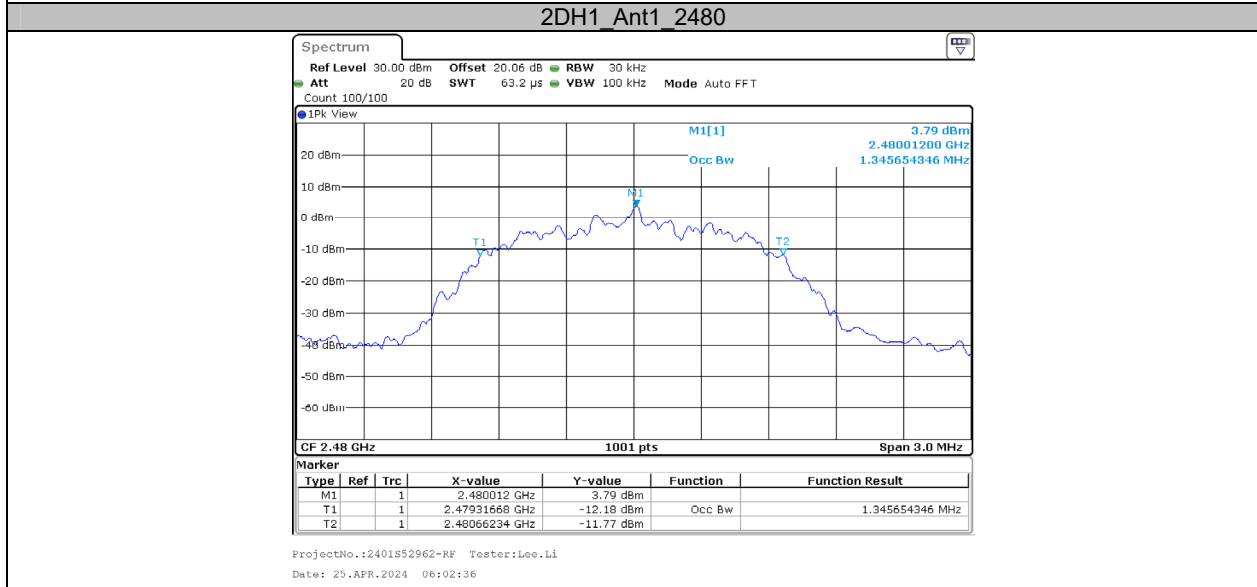
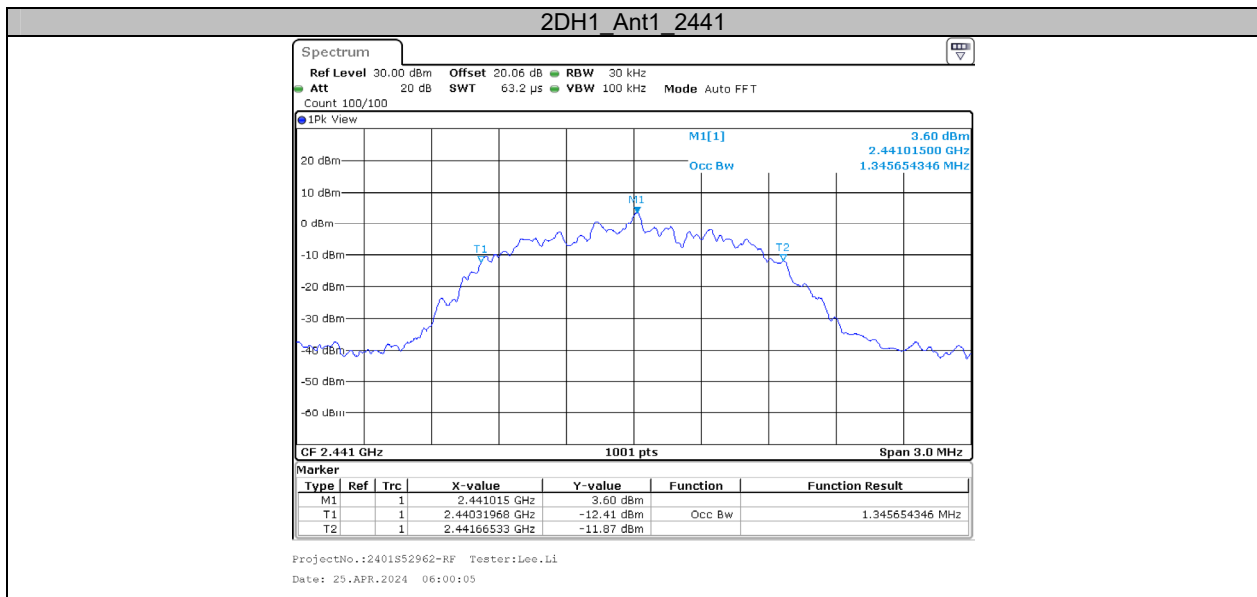



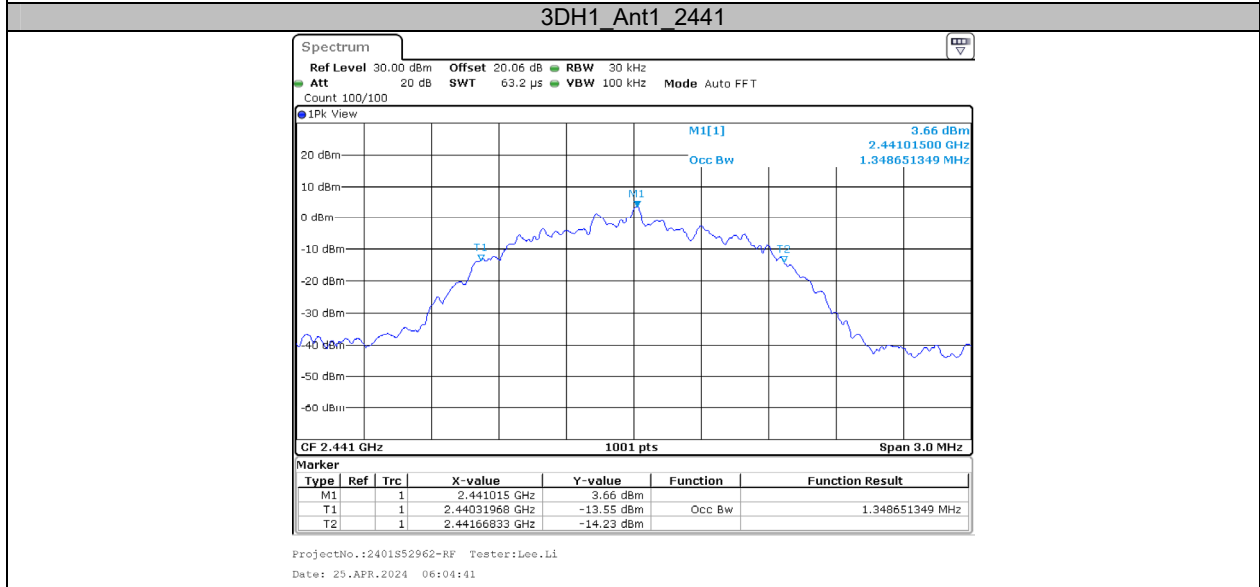
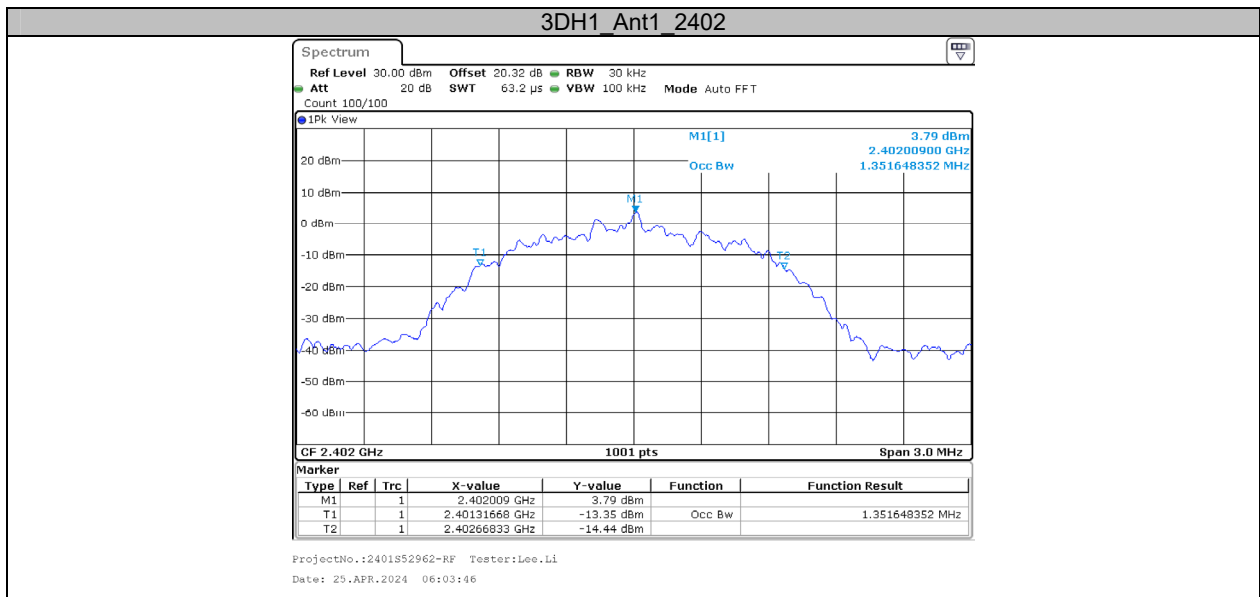

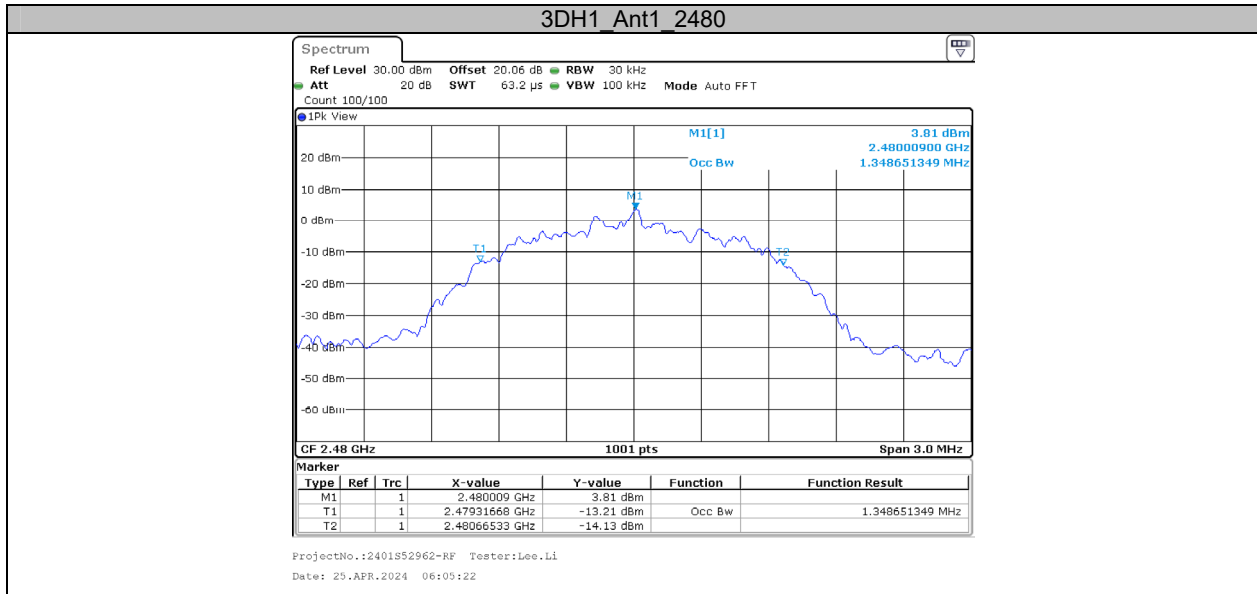

**Appendix C: Maximum conducted output power****Test Result**

Test Mode	Antenna	Frequency[MHz]	Conducted Peak Power[dBm]	Conducted Limit[dBm]	EIRP[dBm]	EIRP Limit[dBm]	Verdict
DH1	Ant1	2402	4.36	≤20.97	6.68	≤36	PASS
		2441	4.26	≤20.97	6.58	≤36	PASS
		2480	4.40	≤20.97	6.72	≤36	PASS
2DH1	Ant1	2402	7.83	≤20.97	10.15	≤36	PASS
		2441	7.66	≤20.97	9.98	≤36	PASS
		2480	7.85	≤20.97	10.17	≤36	PASS
3DH1	Ant1	2402	8.05	≤20.97	10.37	≤36	PASS
		2441	7.86	≤20.97	10.18	≤36	PASS
		2480	8.08	≤20.97	10.40	≤36	PASS

### Test Graphs

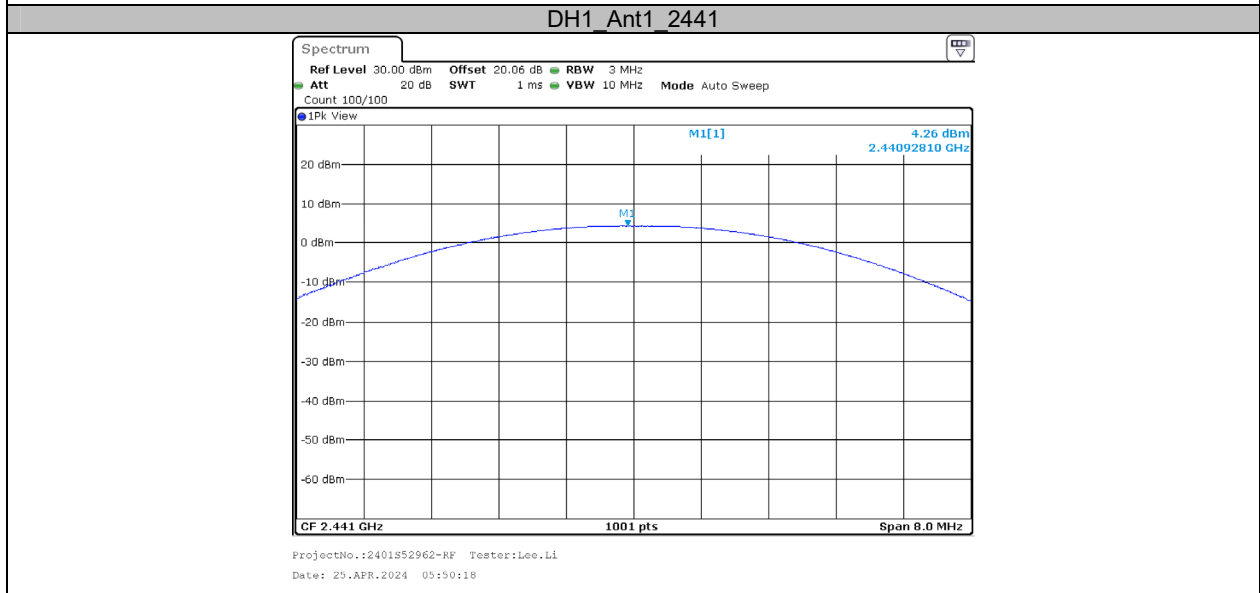
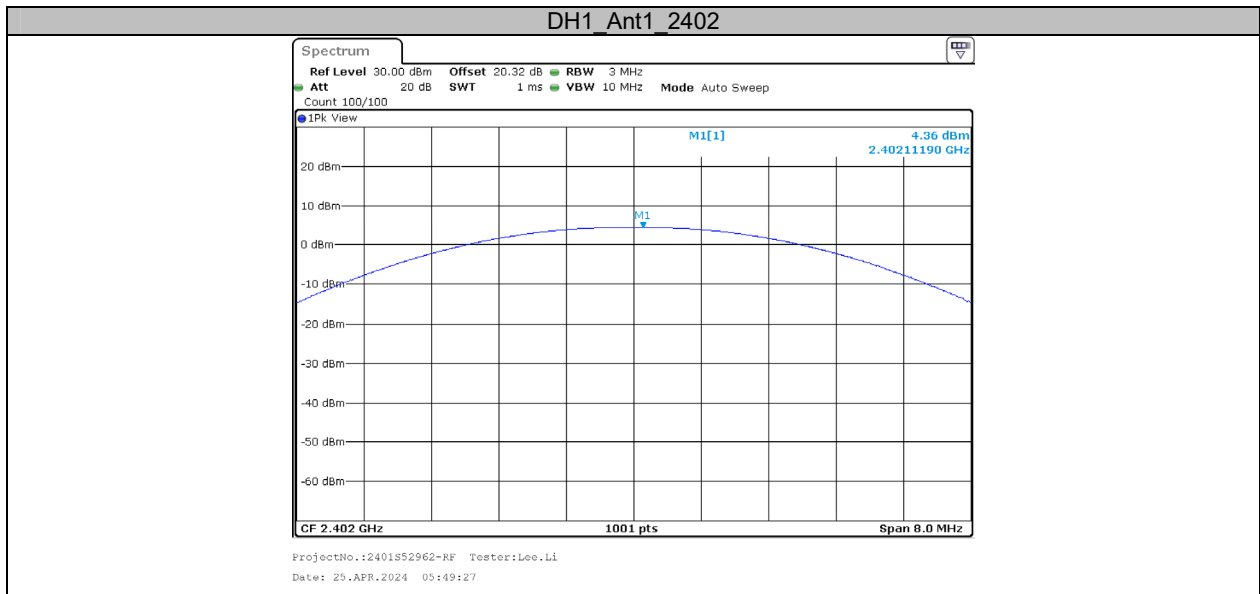



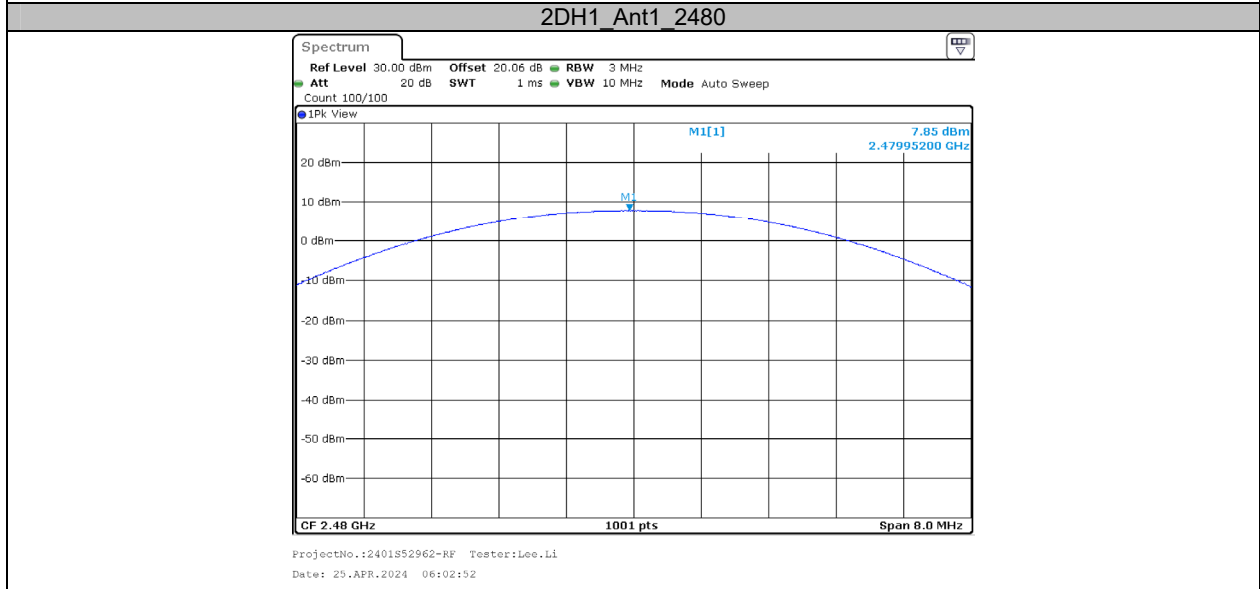
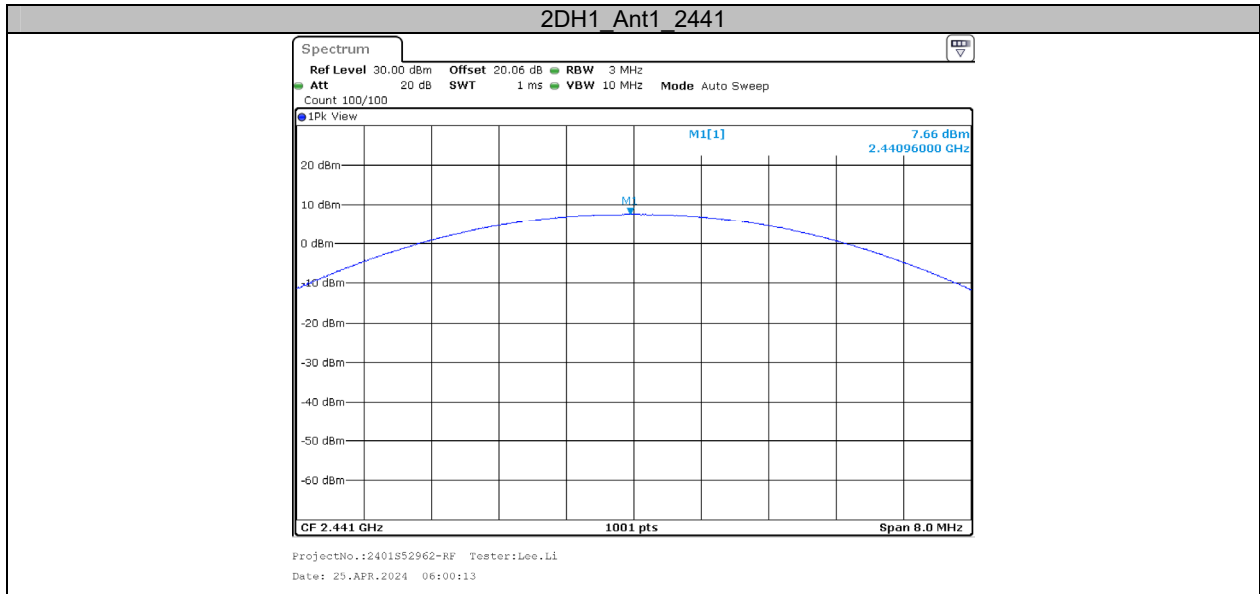

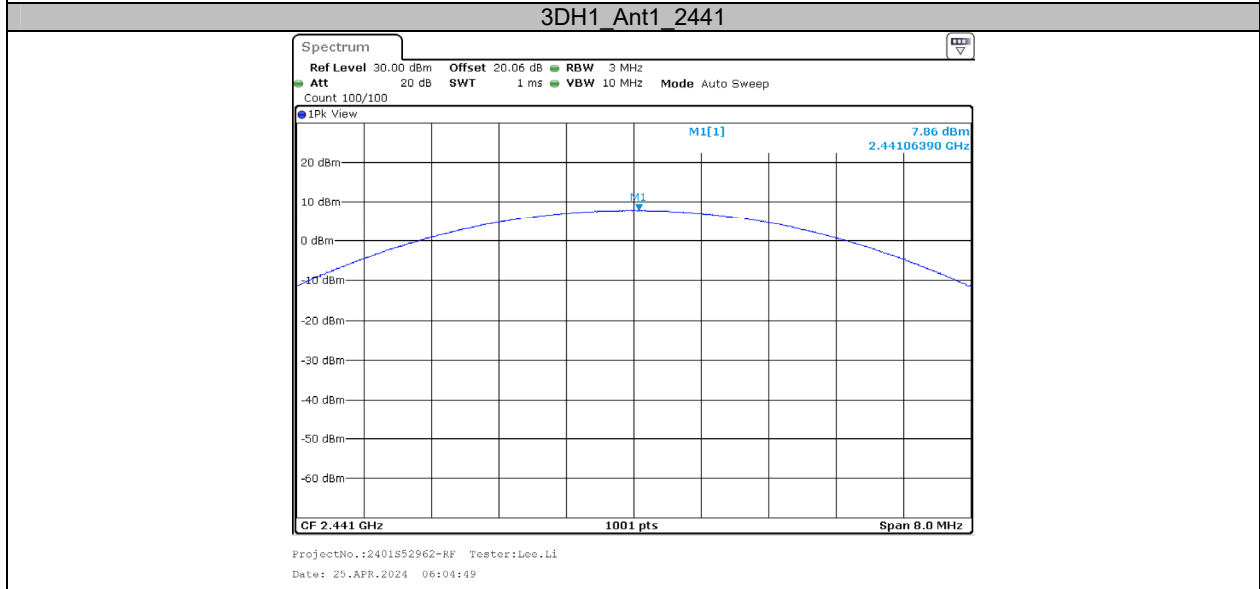
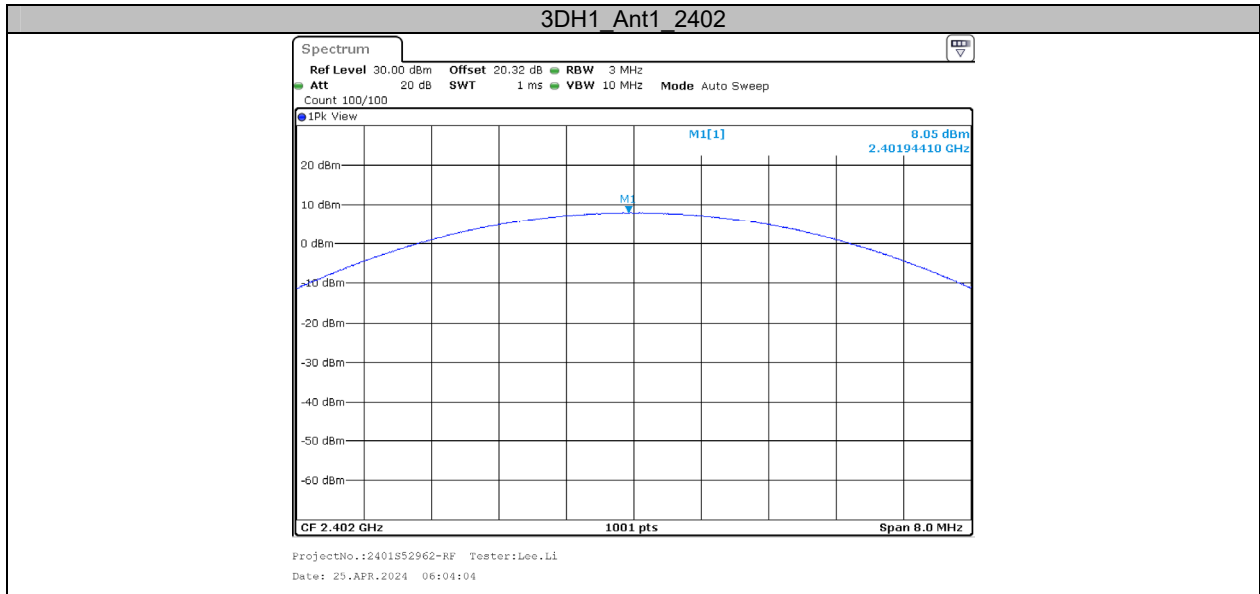

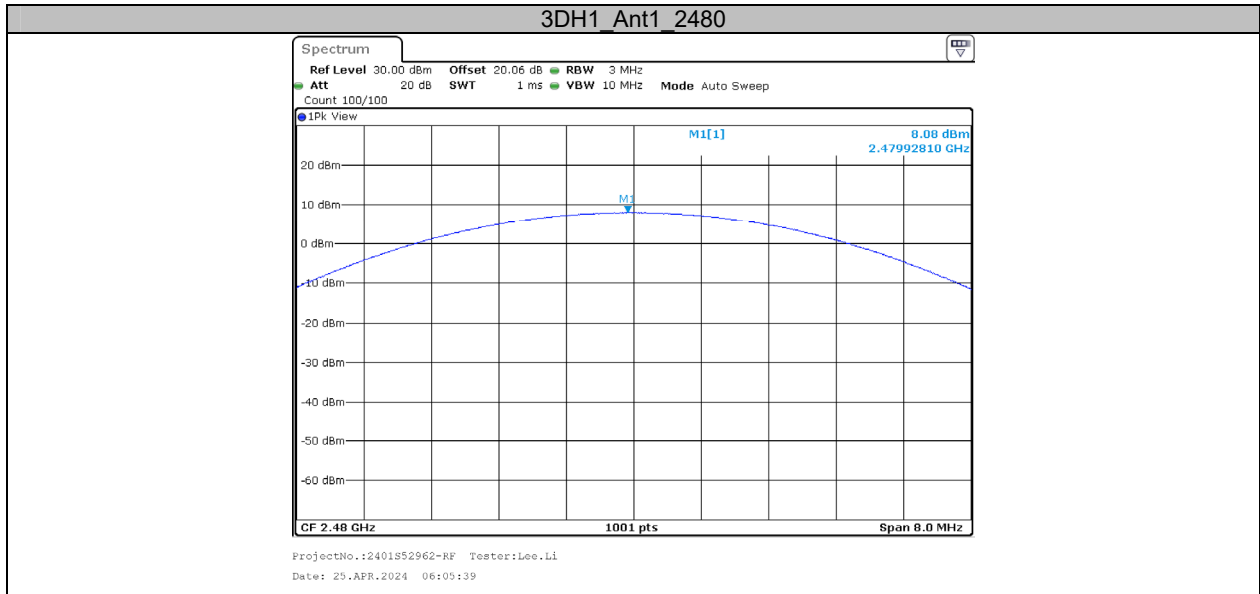



### Appendix D: Carrier frequency separation

#### Test Result

Test Mode	Antenna	Frequency[MHz]	Result[MHz]	Limit[MHz]	Verdict
DH1	Ant1	Hop	1.003	≥0.593	PASS
2DH1	Ant1	Hop	0.994	≥0.953	PASS
3DH1	Ant1	Hop	1	≥0.960	PASS

#### Test Graphs

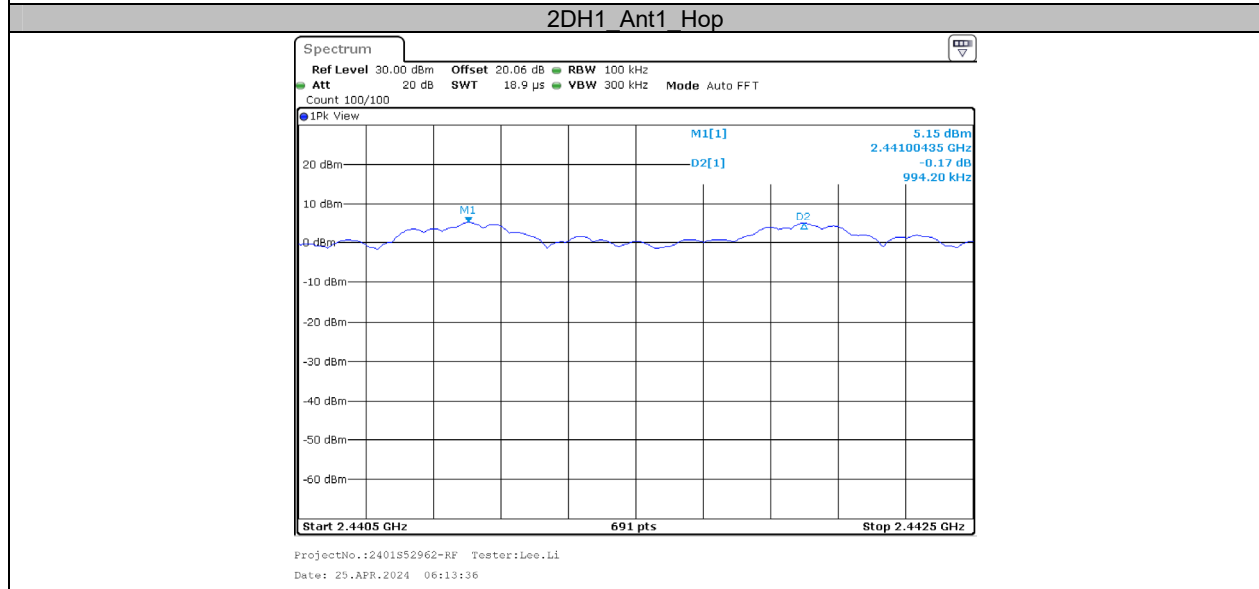
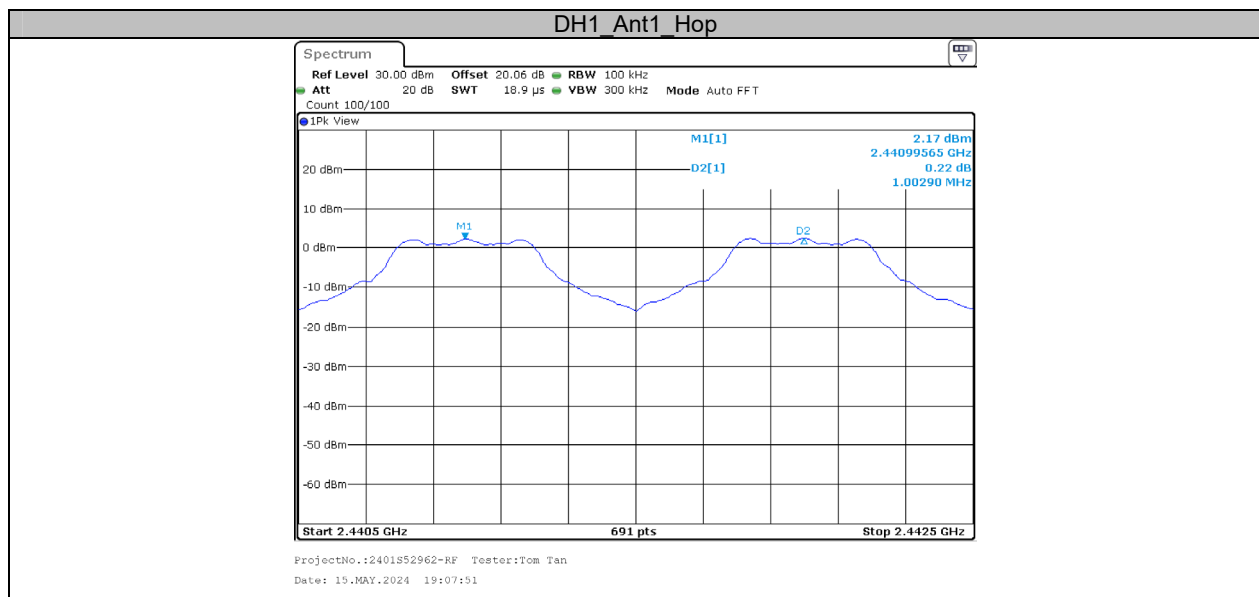

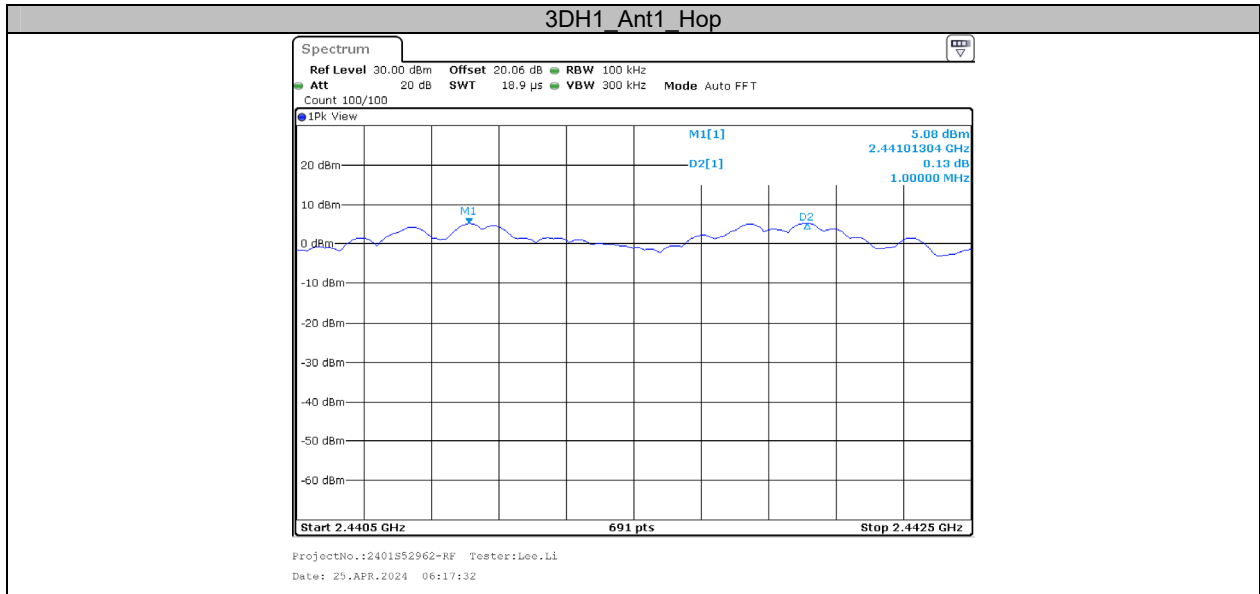

**Appendix E: Time of occupancy****Test Result**

Test Mode	Antenna	Frequency[MHz]	BurstWidth [ms]	TotalHops [Num]	Result[s]	Limit[s]	Verdict
DH1	Ant1	Hop	0.376	320	0.120	≤0.4	PASS
DH3	Ant1	Hop	1.625	170	0.276	≤0.4	PASS
DH5	Ant1	Hop	2.865	120	0.344	≤0.4	PASS
2DH1	Ant1	Hop	0.385	320	0.123	≤0.4	PASS
2DH3	Ant1	Hop	1.629	150	0.244	≤0.4	PASS
2DH5	Ant1	Hop	2.869	110	0.316	≤0.4	PASS
3DH1	Ant1	Hop	0.385	320	0.123	≤0.4	PASS
3DH3	Ant1	Hop	1.630	150	0.245	≤0.4	PASS
3DH5	Ant1	Hop	2.873	120	0.345	≤0.4	PASS

Note 1: A period time=0.4\*79=31.6(S), Result=BurstWidth\*Totalhops

Note 2: Totalhops=Hopping Number in 3.16s\*10

Note 3: Hopping Number in 3.16s=Total of highest signals in 3.16s(Second high signals were other channel)

### Test Graphs

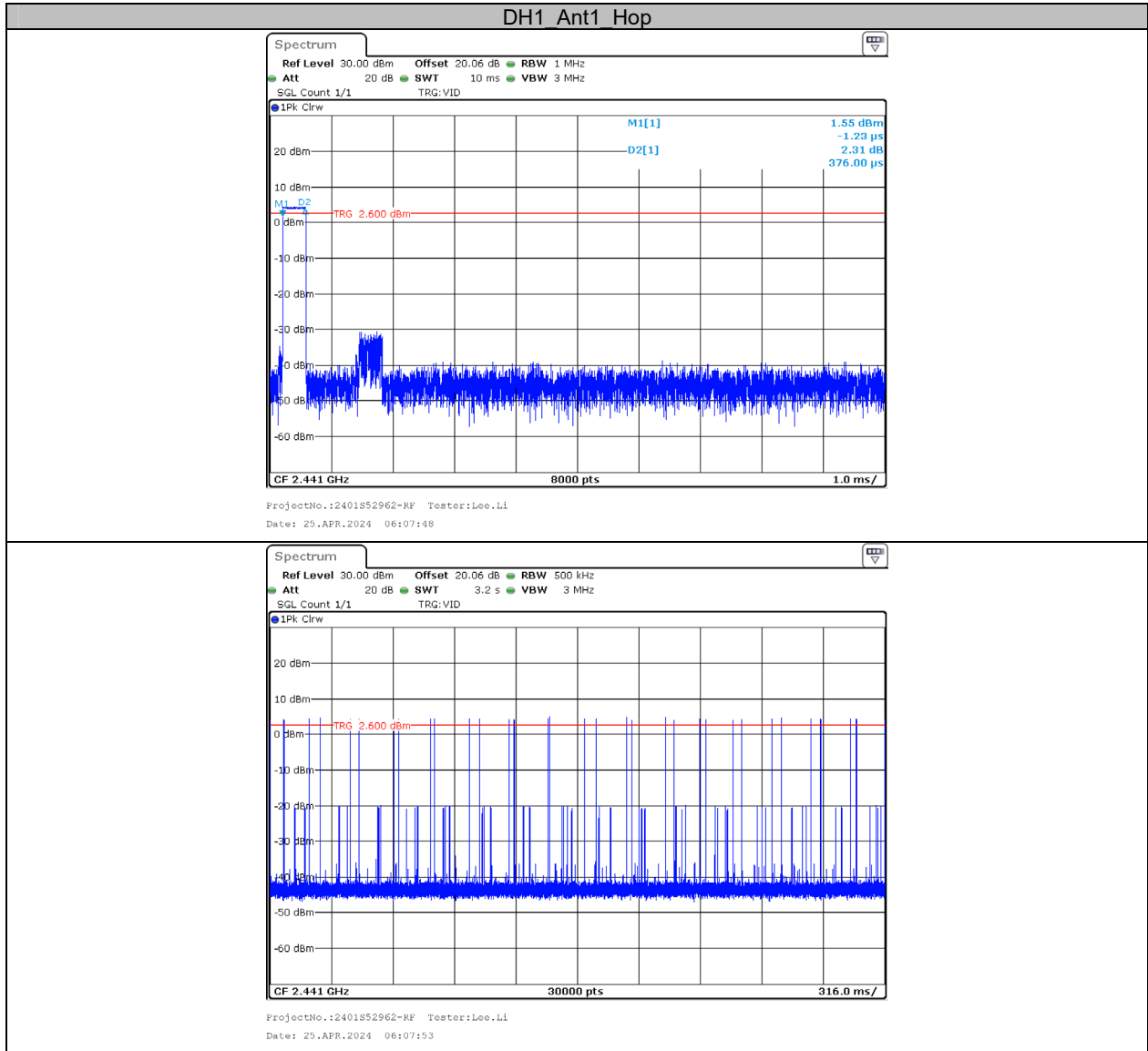

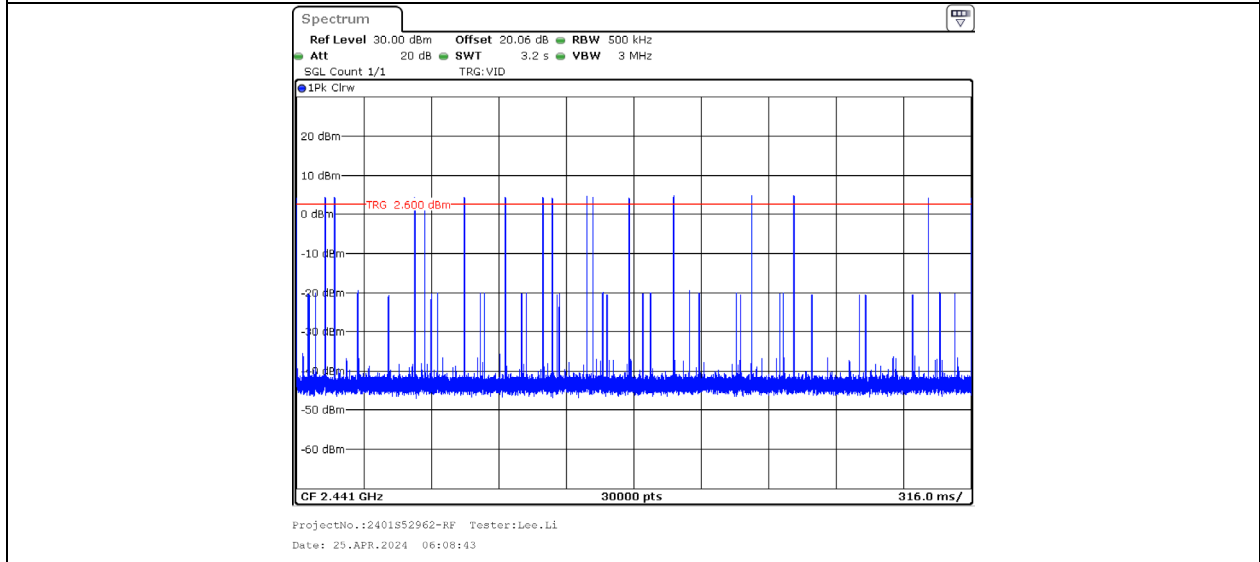
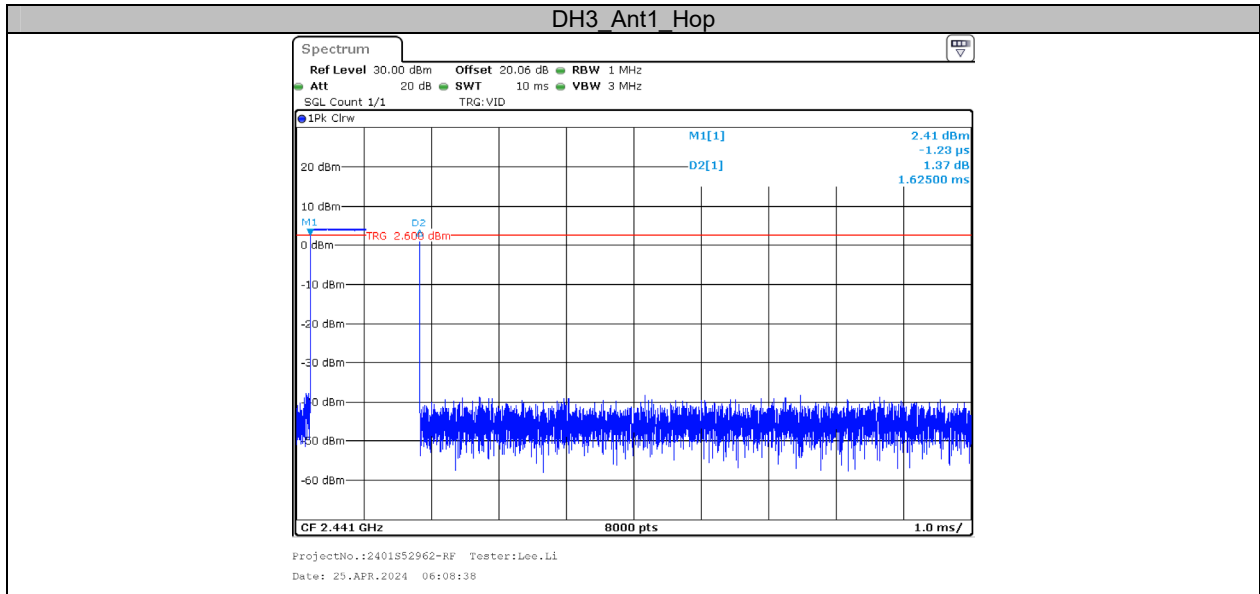

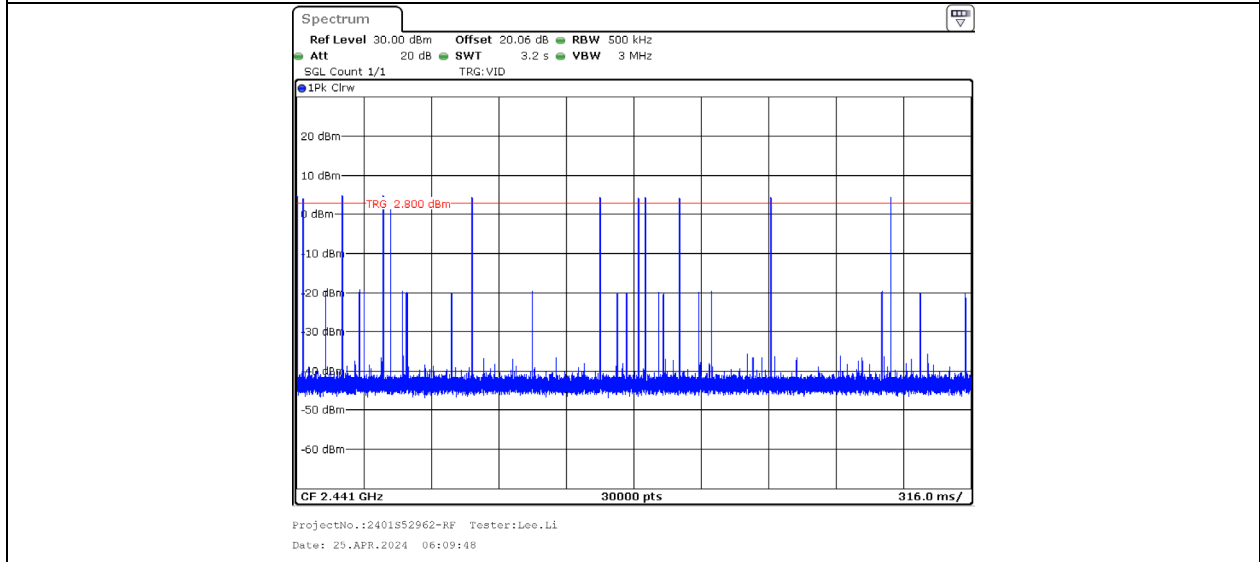
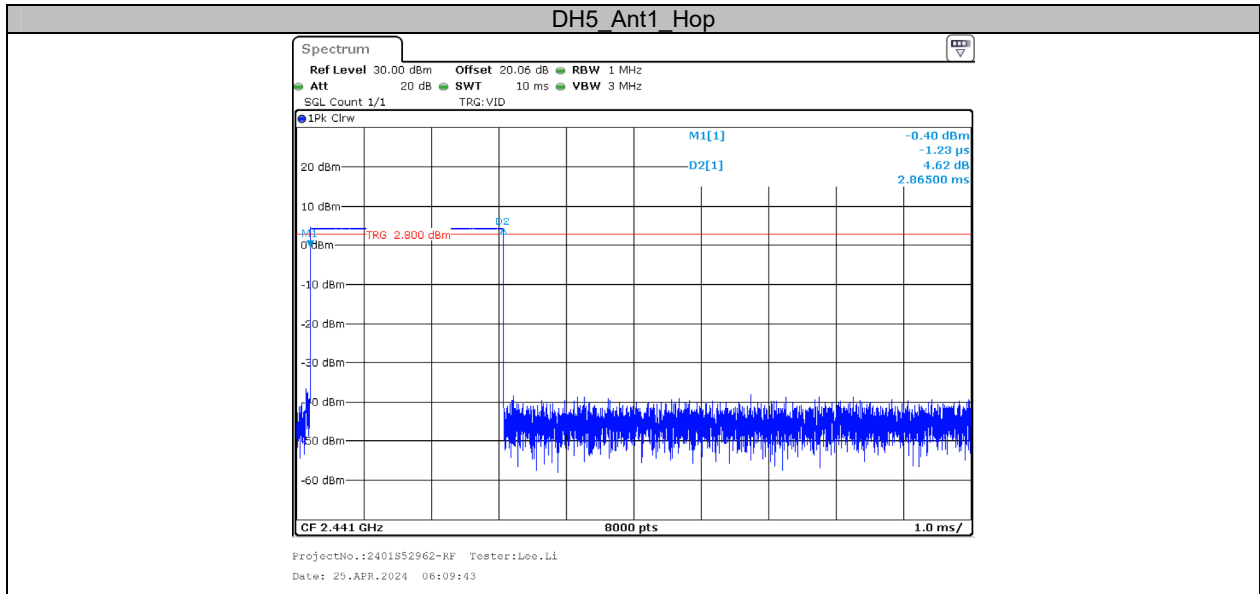

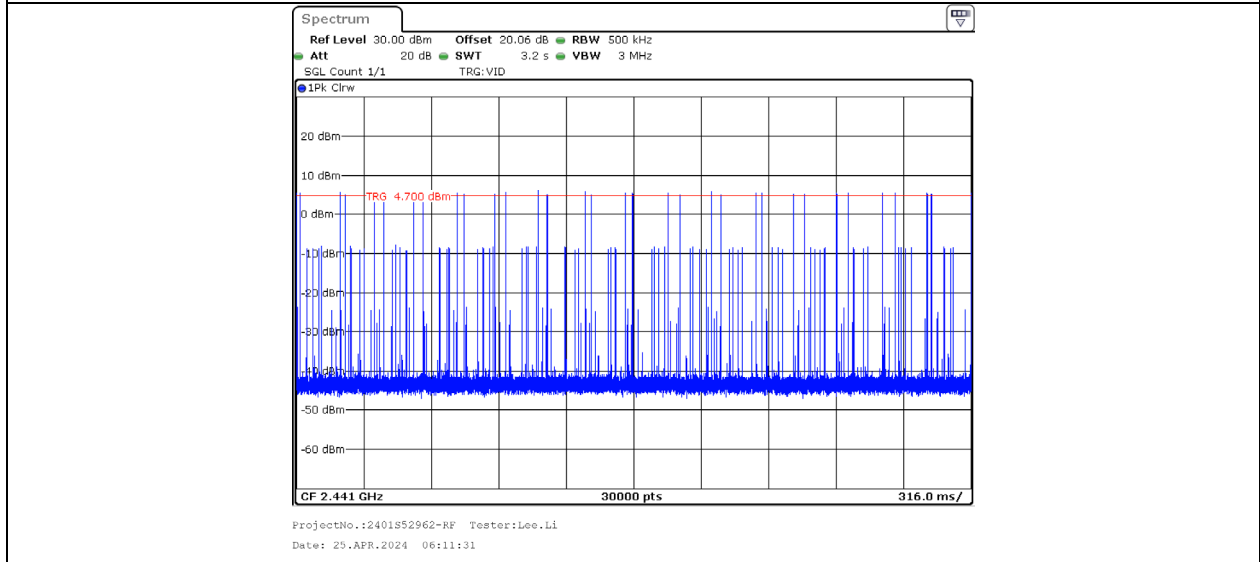
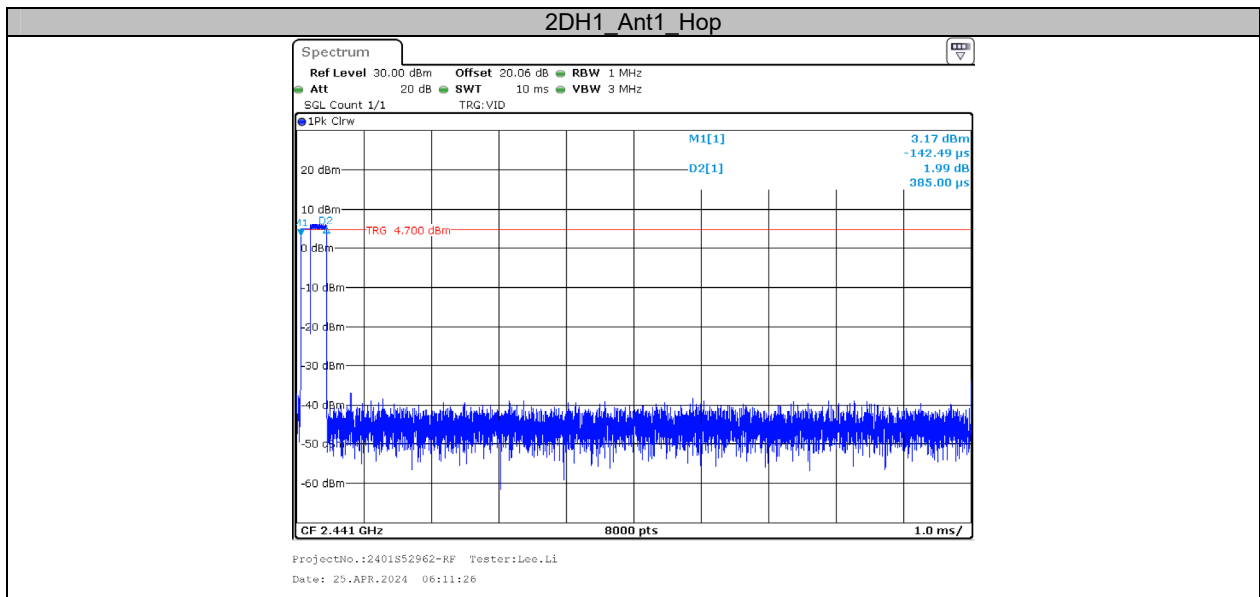

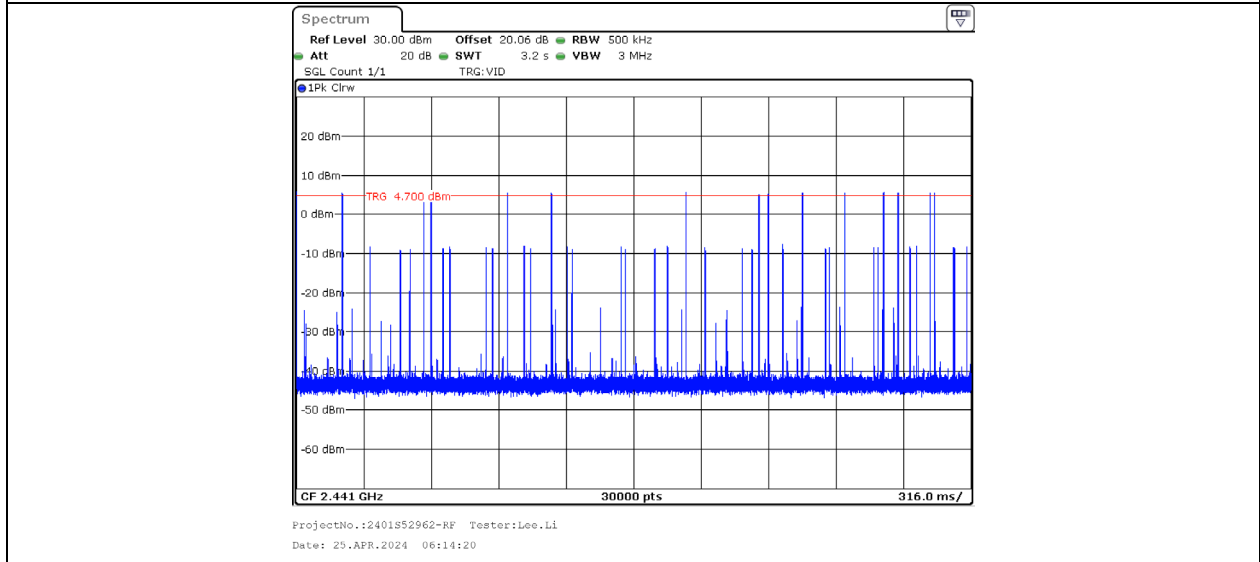
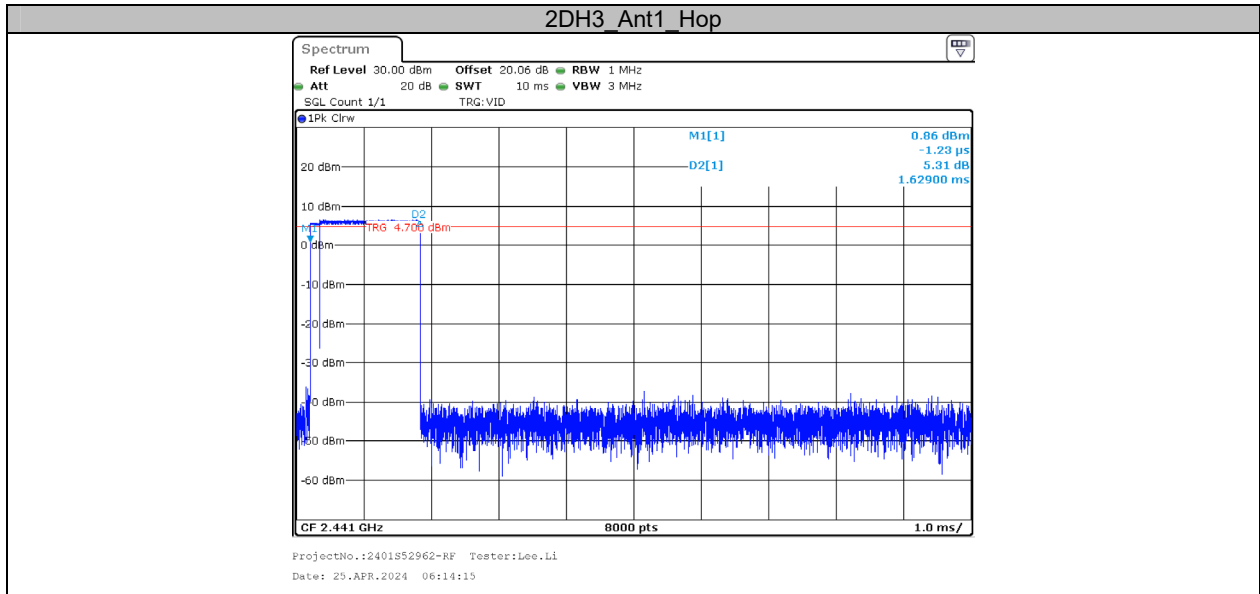



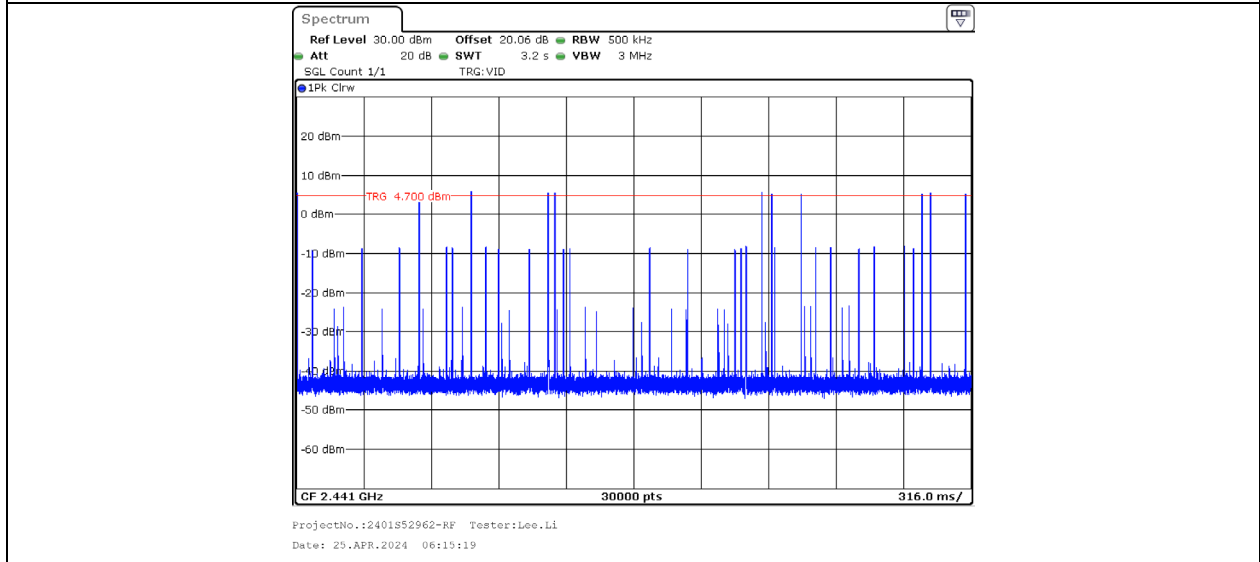
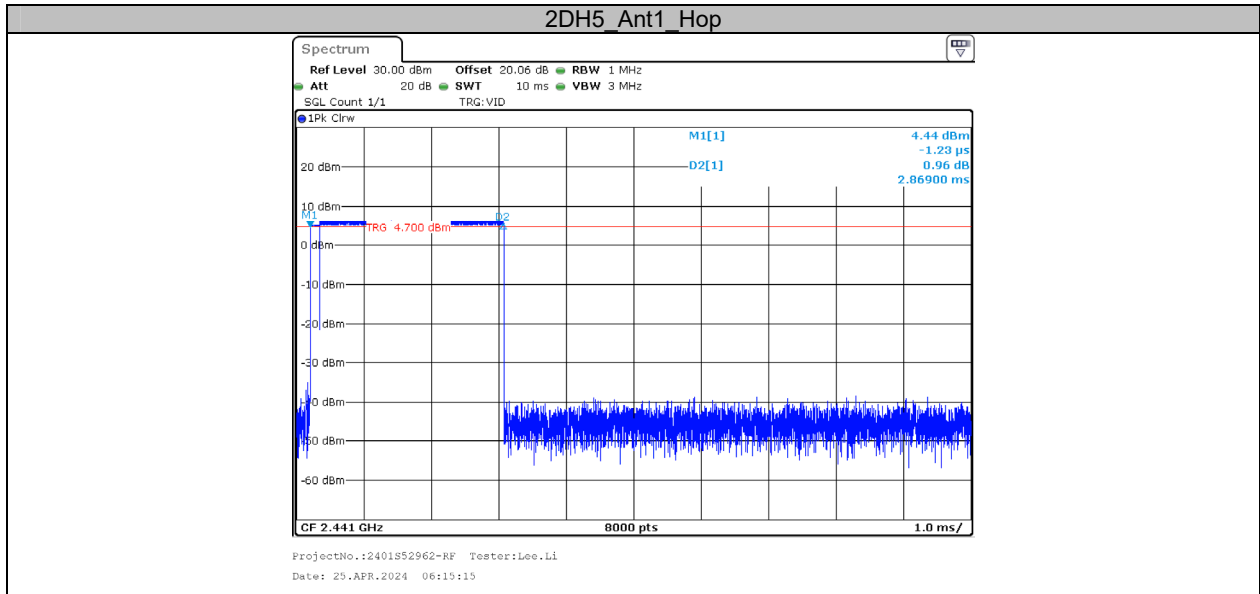

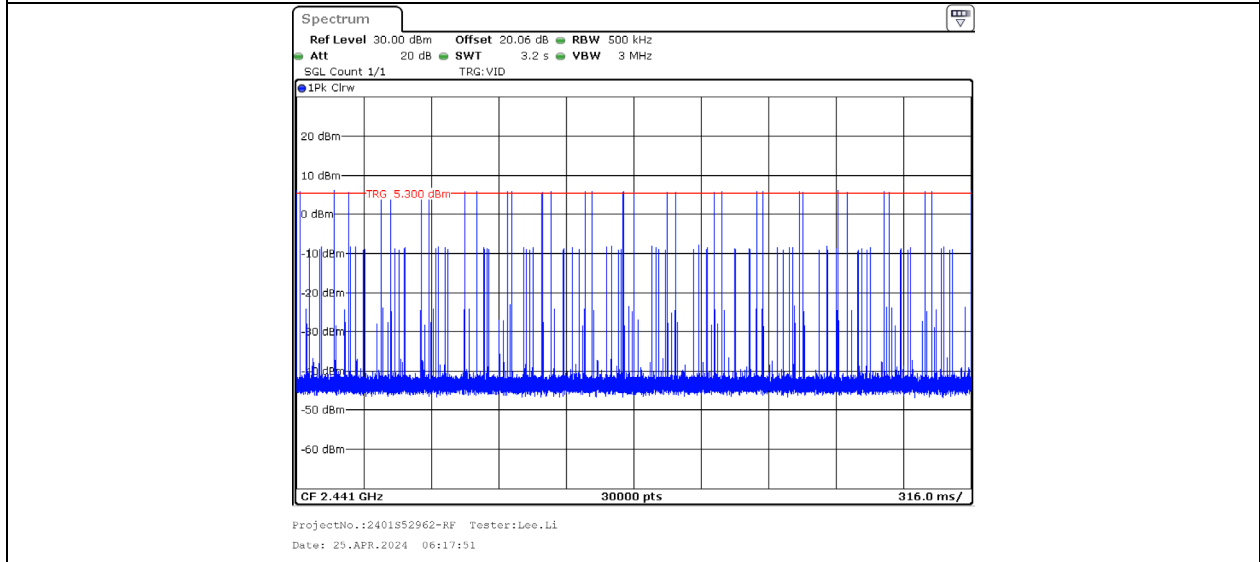
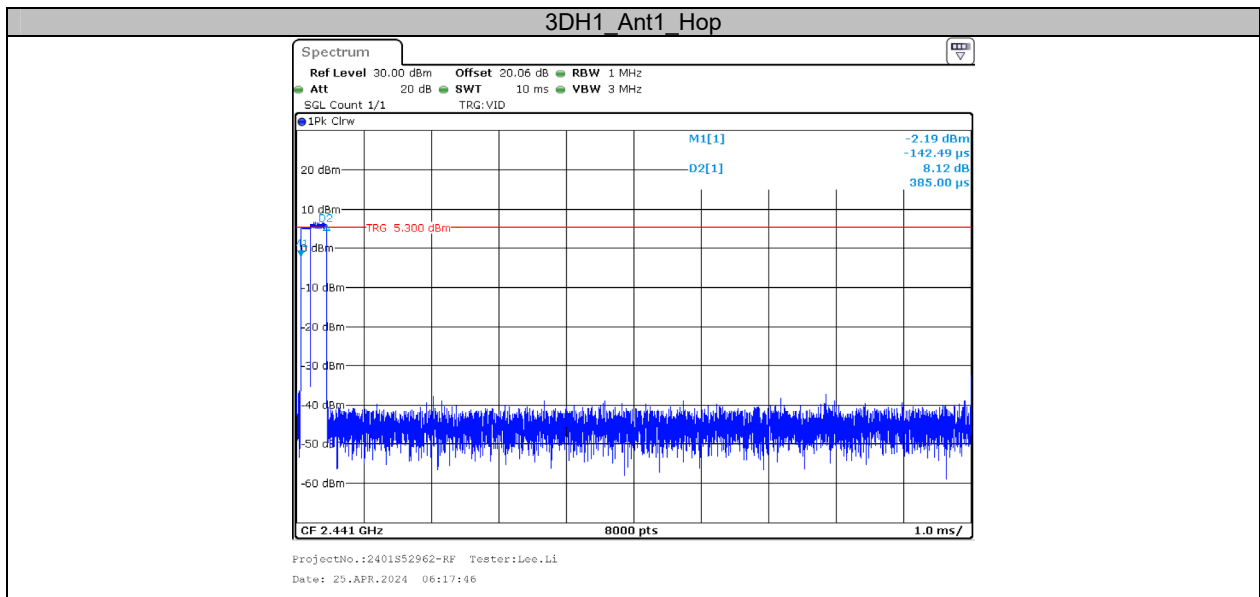

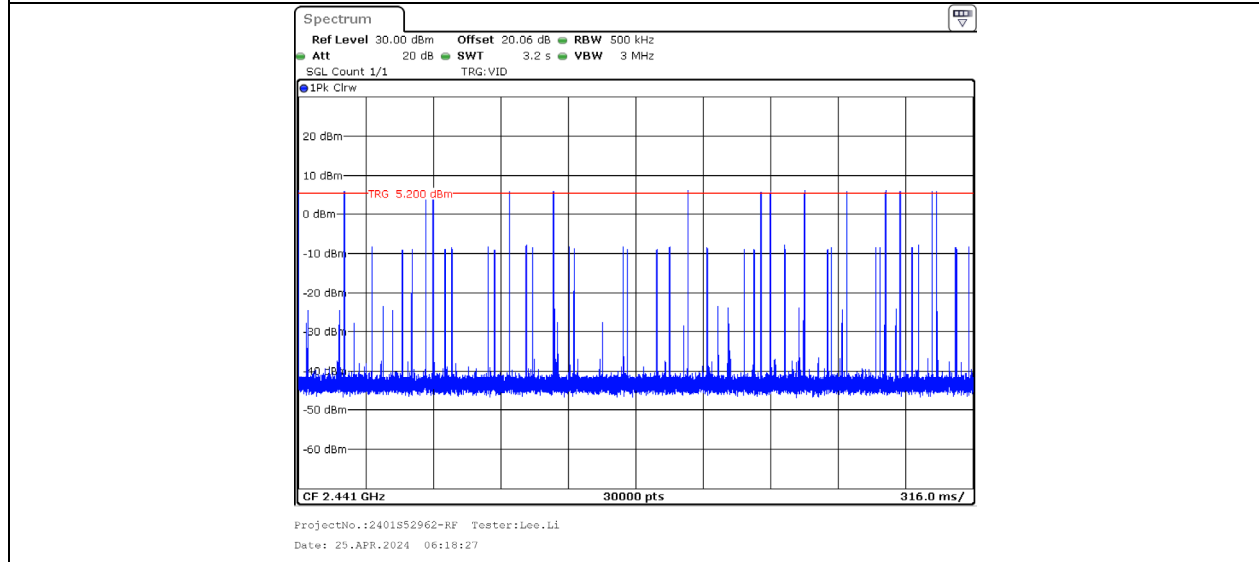
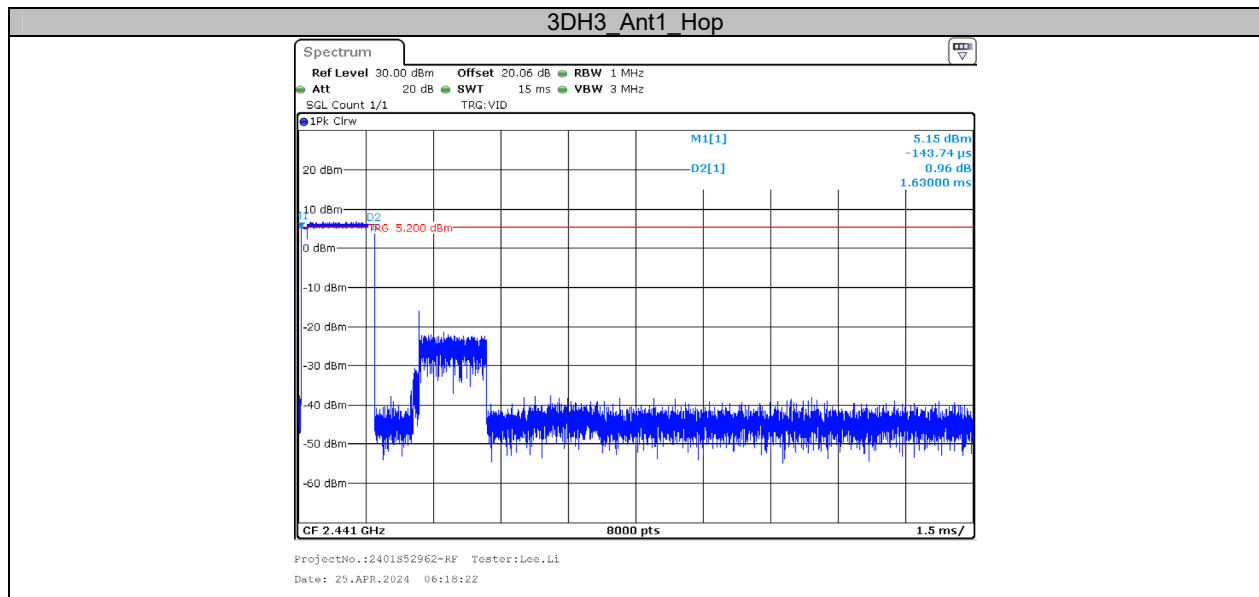

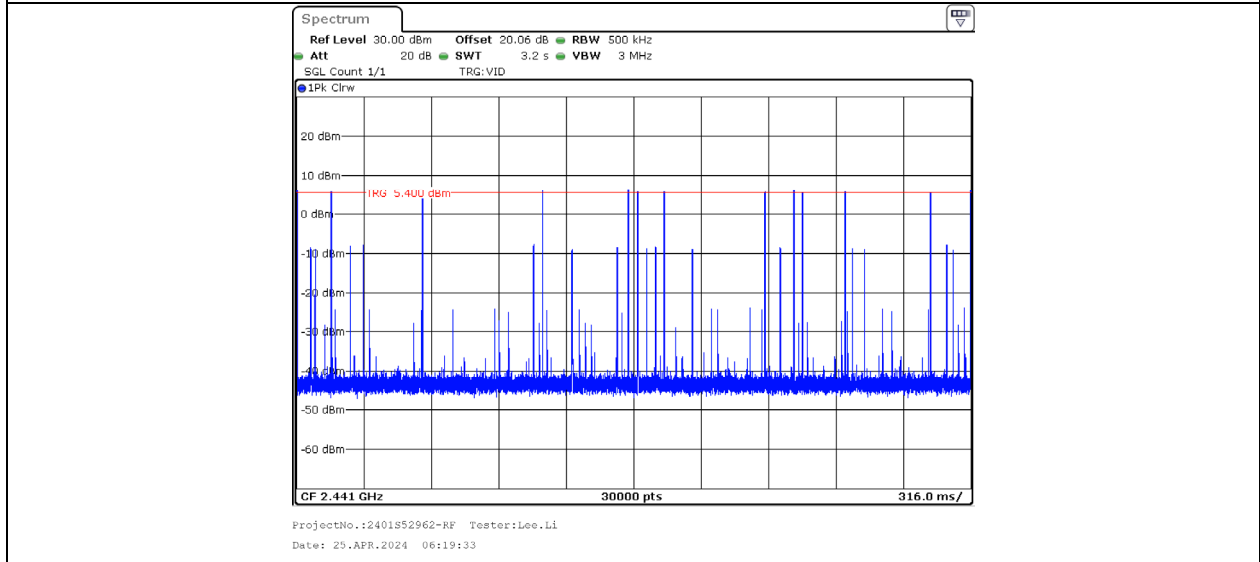
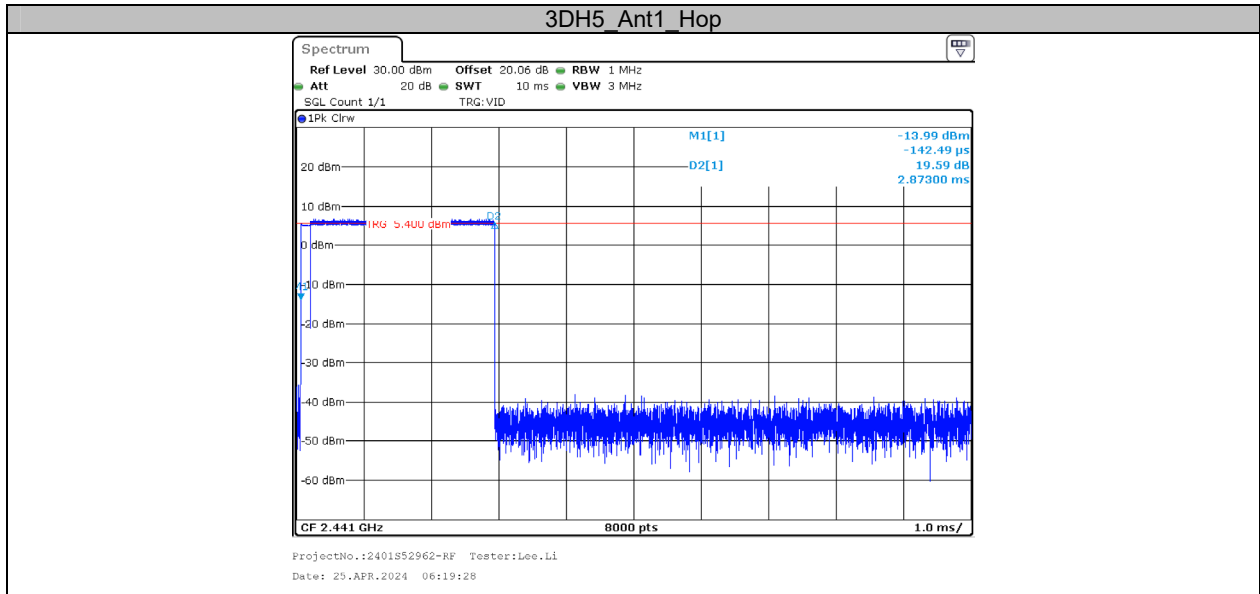

### Appendix F: Number of hopping channels

#### Test Result

Test Mode	Antenna	Frequency[MHz]	Result[Num]	Limit[Num]	Verdict
DH1	Ant1	Hop	79	≥15	PASS
2DH1	Ant1	Hop	79	≥15	PASS
3DH1	Ant1	Hop	79	≥15	PASS

#### Test Graphs

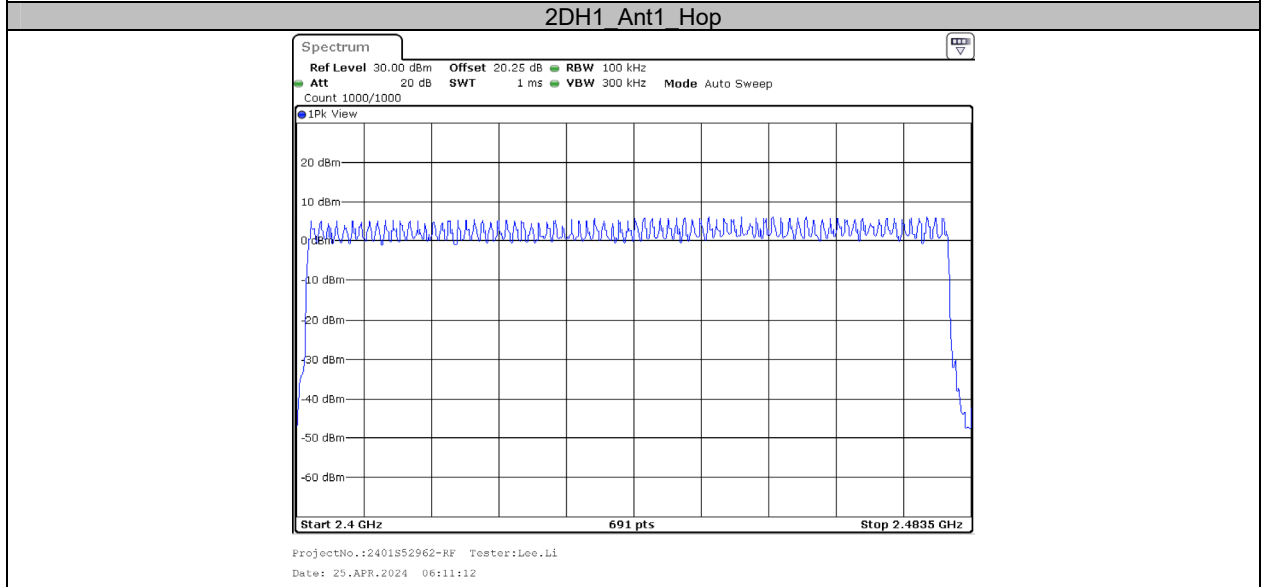
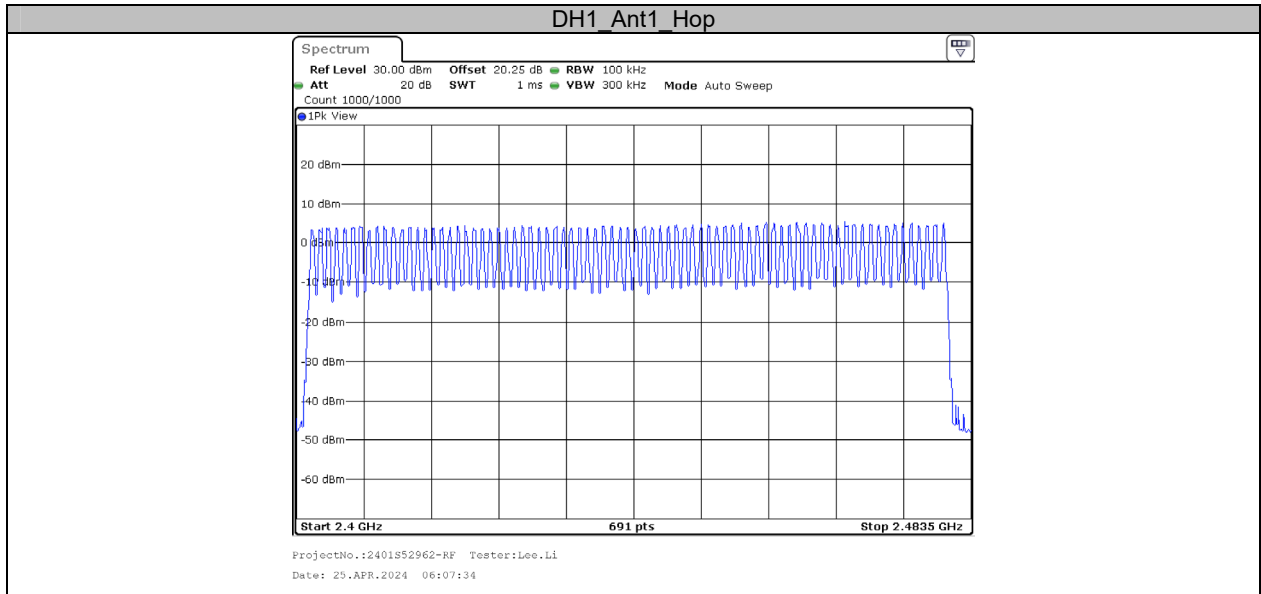



### Appendix G: Band edge measurements

#### Test Graphs

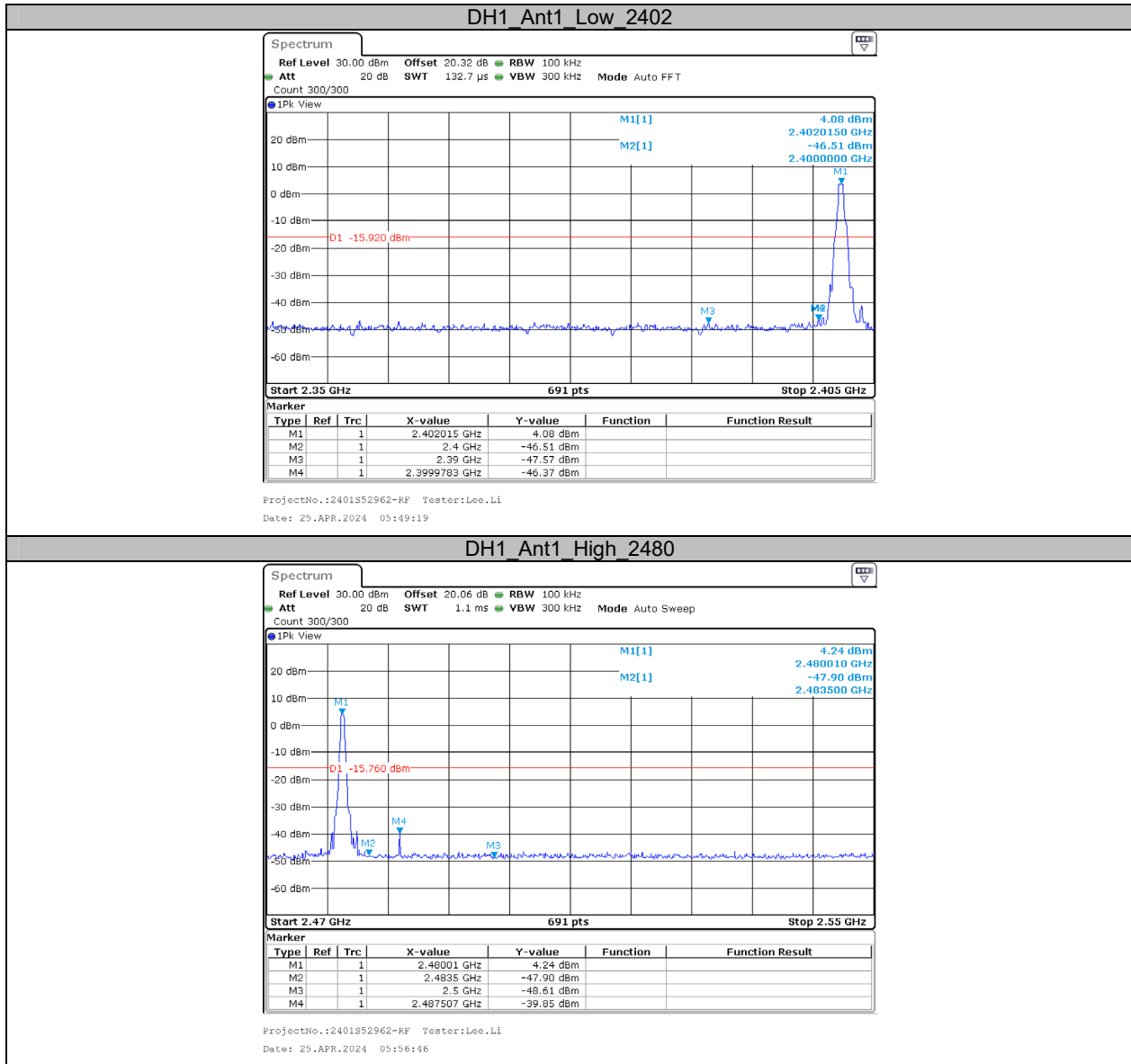

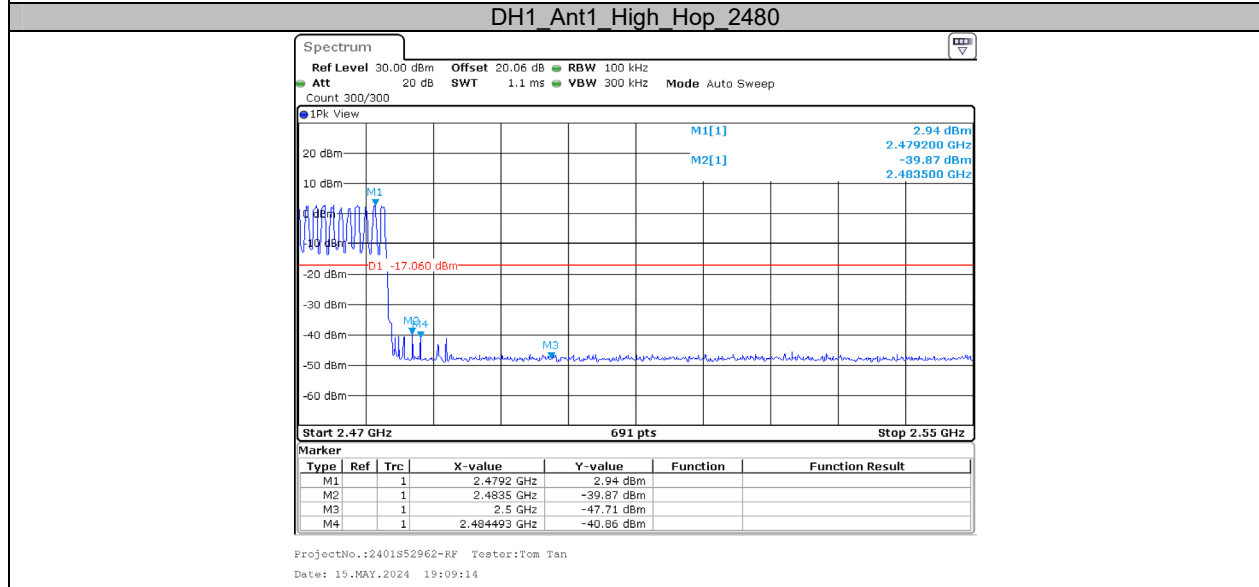
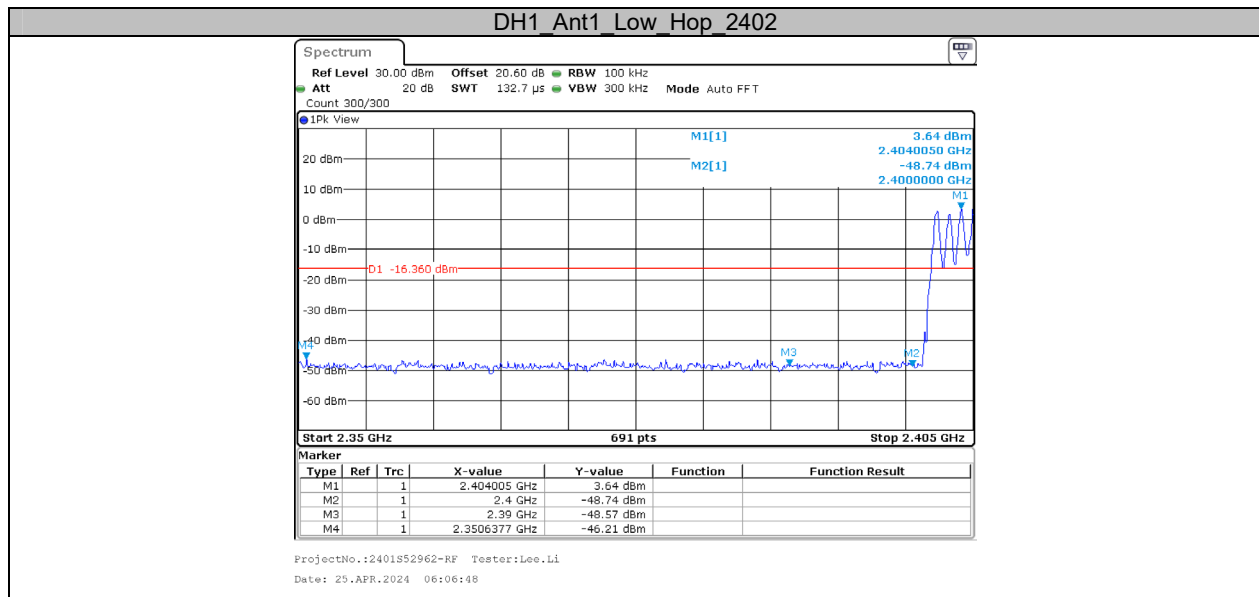



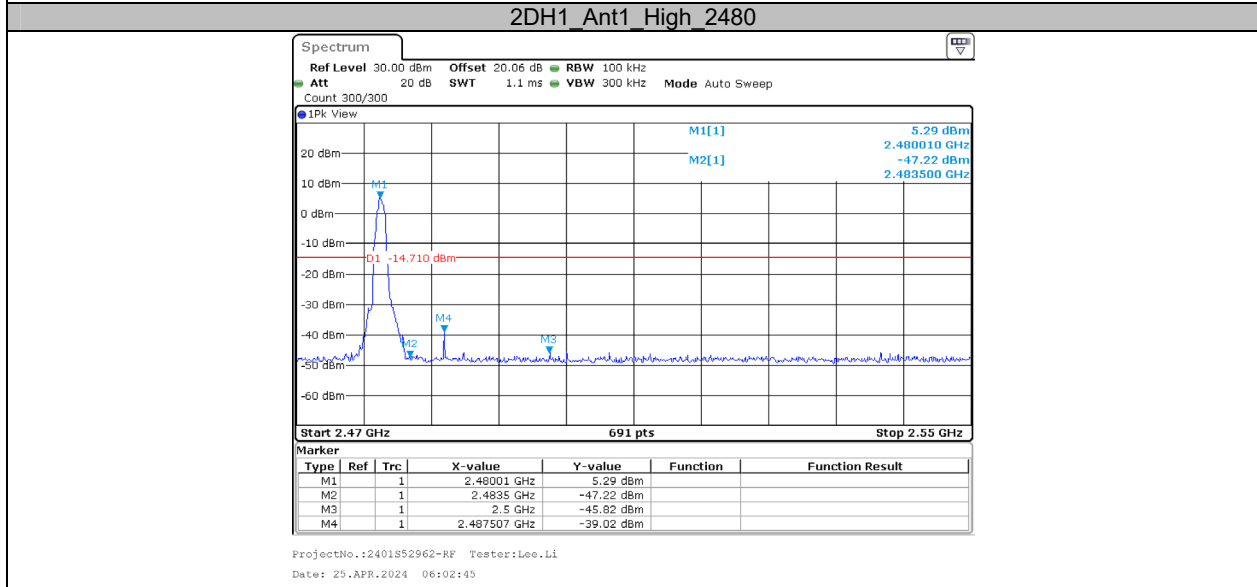
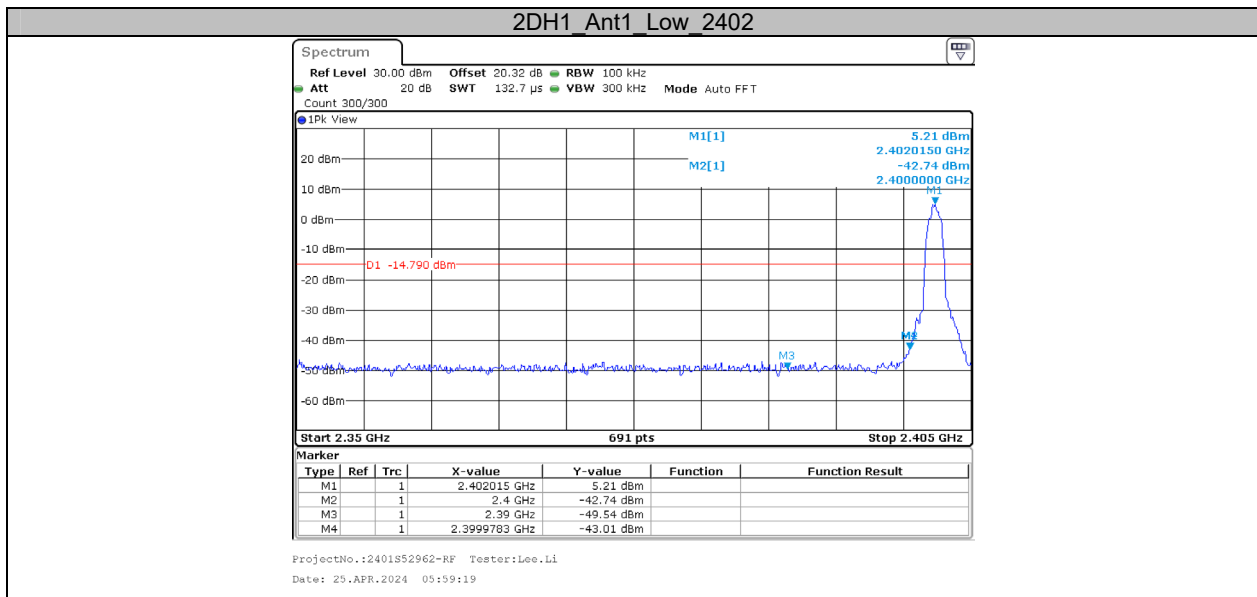

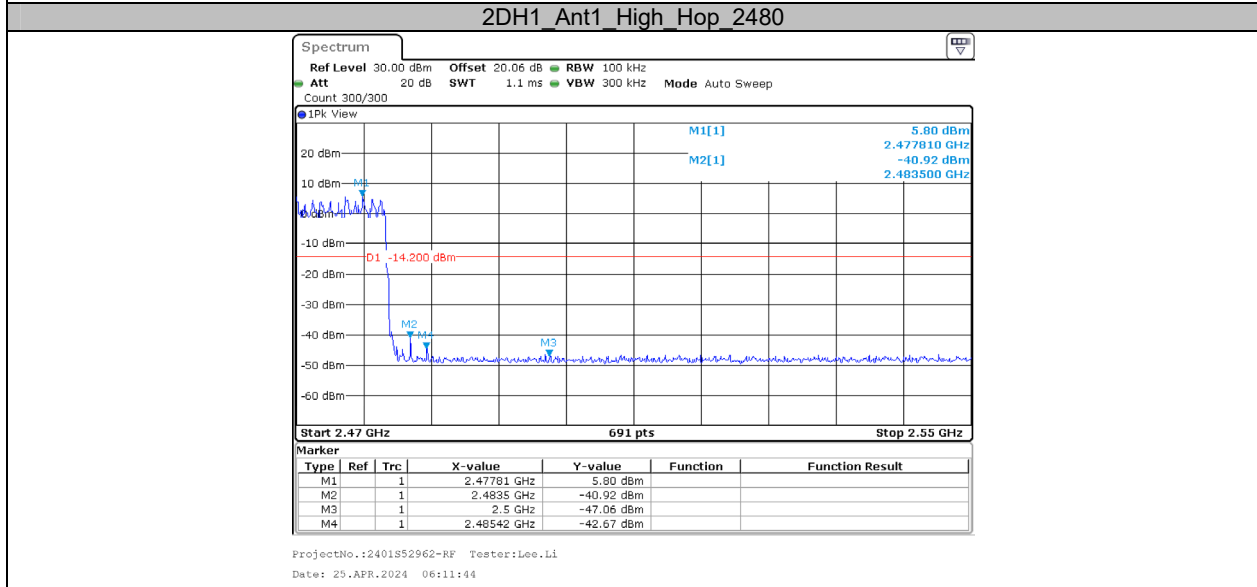
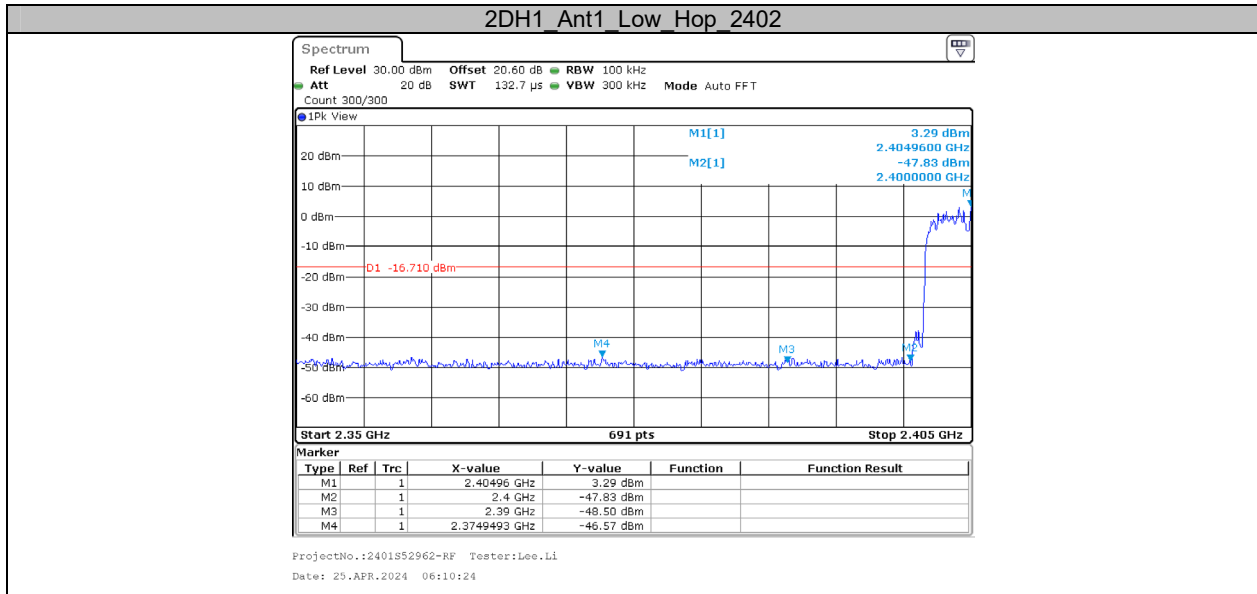

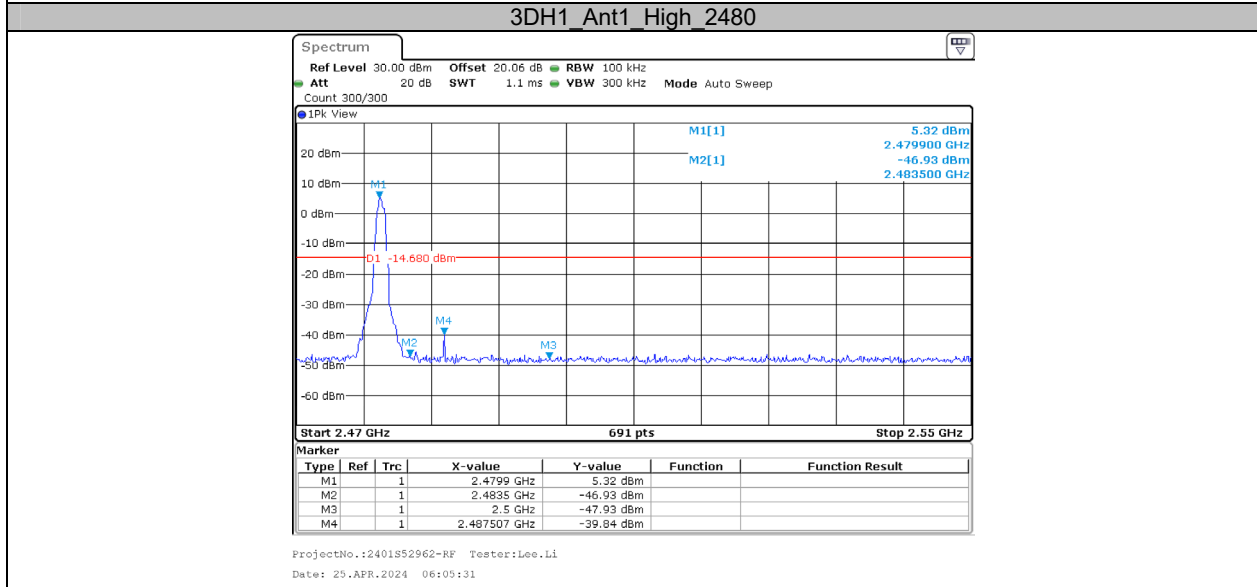
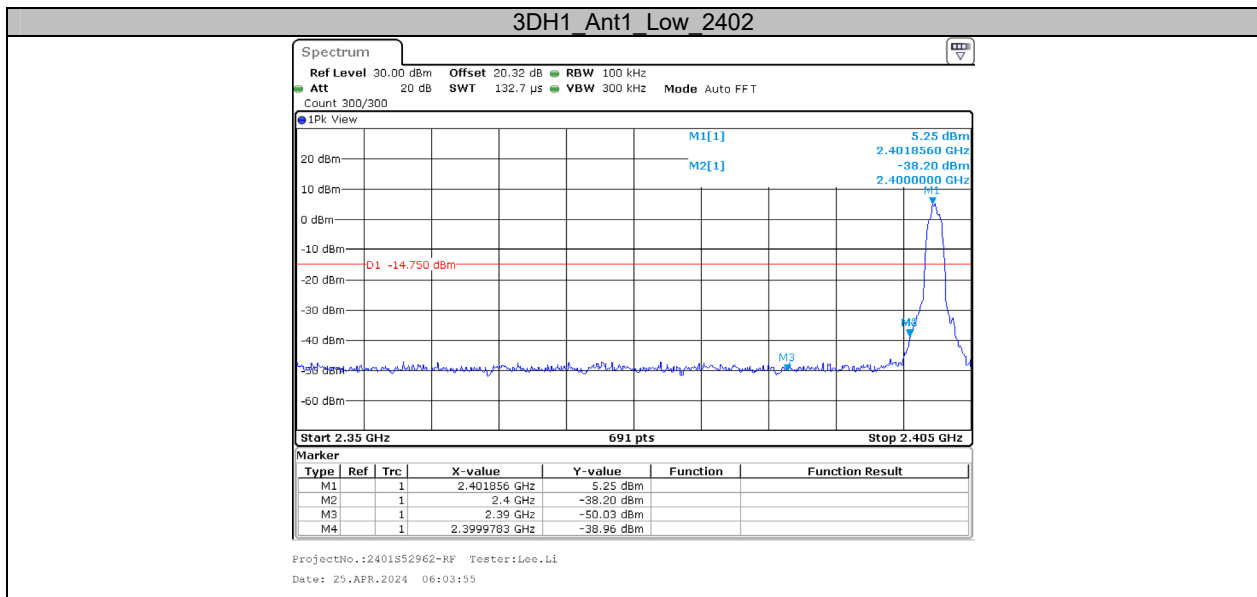

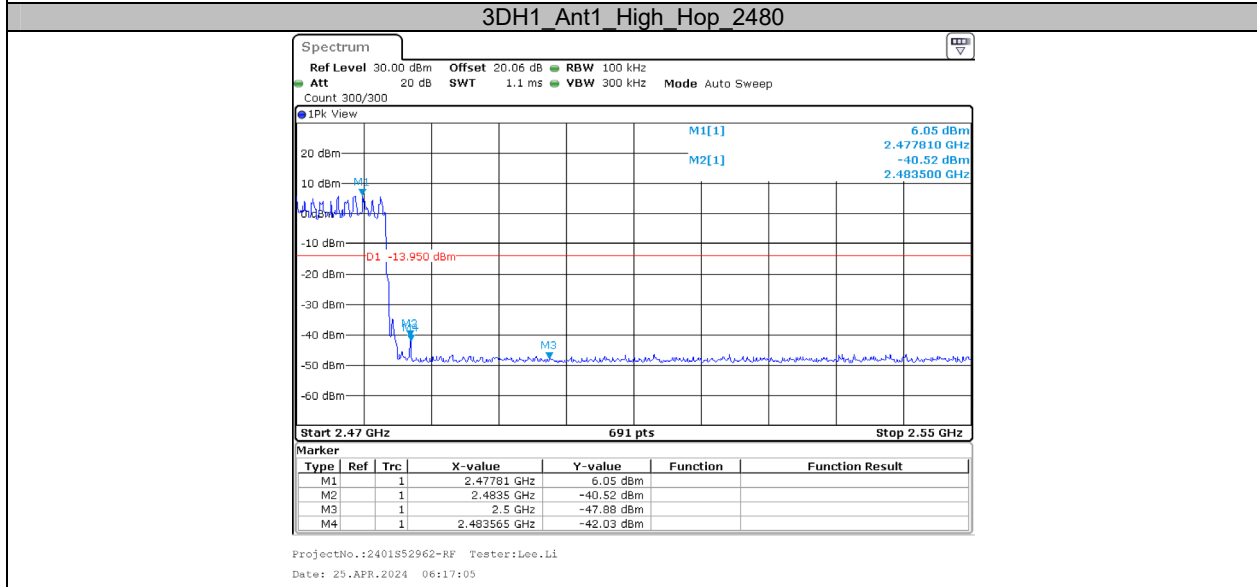
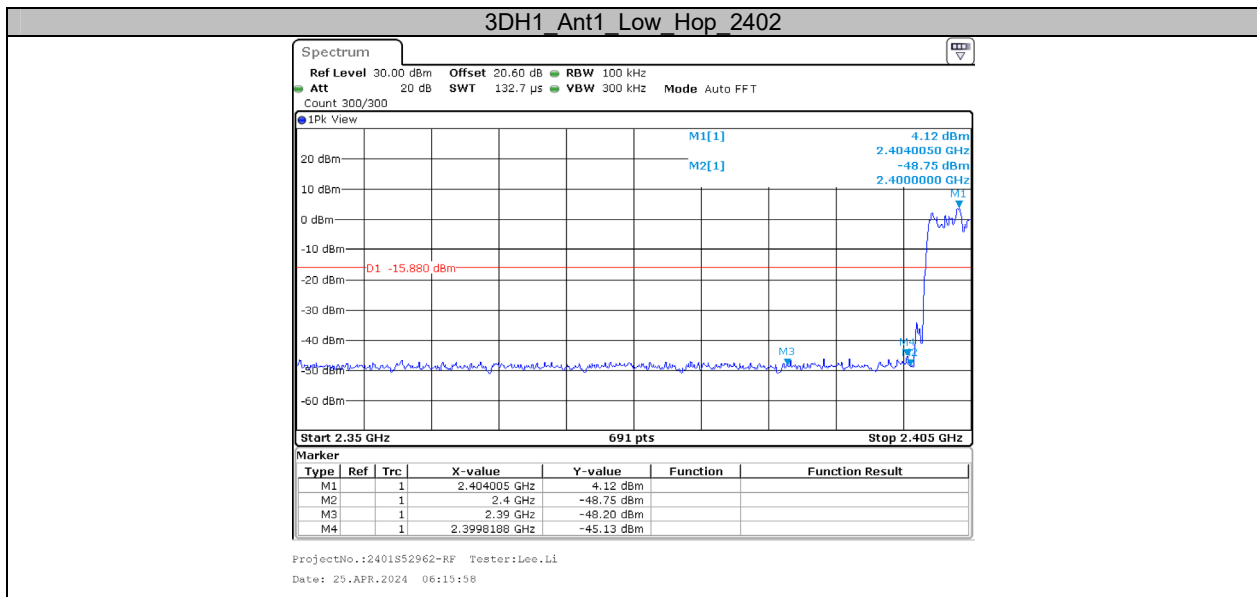

\*\*\*\*\* END OF REPORT \*\*\*\*\*