

# TEST REPORT

For DECT

**Report No.** ..... : **CHEW22110031** Report Verification:   
**Project No.**..... : **SHT2112112201EW**  
**FCC ID**..... : **T2C-CP935W**  
**Applicant's name**..... : **YEALINK(XIAMEN) NETWORK TECHNOLOGY CO.,LTD.**  
**Address**..... : No.666 Hu' an Rd,Huli District Xiamen City, Fujian, P.R. China  
**Product Name** ..... : **HD Wireless Conference Phone**  
**Trade Mark** ..... : YEALINK  
**Model No.** ..... : CP935W  
**Listed Model(s)** ..... : -  
**Standard** ..... : **FCC CFR Title 47 Part 15 Subpart D**  
**Date of receipt of test sample**..... : Oct.19, 2022  
**Date of testing**..... : Oct.20, 2022- Nov.17, 2022  
**Date of issue**..... : Nov.18, 2022  
**Result**..... : **PASS**

Compiled by  
(Position+Printed name+Signature): File administrator Fanghui Zhu 

Supervised by  
(Position+Printed name+Signature): Project Engineer Xiaodong Zhao 

Approved by  
(Position+Printed name+Signature): RF Manager Hans Hu 

**Testing Laboratory Name** ..... : **Shenzhen Huatongwei International Inspection Co., Ltd.**  
**Address**..... : 1/F, Bldg 3, Hongfa Hi-tech Industrial Park, Genyu Road,  
Tianliao, Gongming, Shenzhen, China

**Shenzhen Huatongwei International Inspection Co., Ltd. All rights reserved.**

This publication may be reproduced in whole or in part for non-commercial purposes as long as the Shenzhen Huatongwei International Inspection Co., Ltd. is acknowledged as copyright owner and source of the material. Shenzhen Huatongwei International Inspection Co., Ltd. takes no responsibility for and will not assume liability for damages resulting from the reader's interpretation of the reproduced material due to its placement and context.

The test report merely correspond to the test sample.

## Contents

<b>1.</b>	<b>TEST STANDARDS AND REPORT VERSION</b>	<b>3</b>
1.1.	Test Standards	3
1.2.	Report version	3
<b>2.</b>	<b>TEST DESCRIPTION</b>	<b>4</b>
<b>3.</b>	<b>SUMMARY</b>	<b>5</b>
3.1.	Client Information	5
3.2.	Product Description	5
3.3.	Radio Specification Description	5
3.4.	Testing Laboratory Information	6
<b>4.</b>	<b>TEST CONFIGURATION</b>	<b>7</b>
4.1.	Test frequency list	7
4.2.	Descriptions of Test mode	7
4.3.	Test sample information	7
4.4.	Support unit used in test configuration and system	7
4.5.	Testing environmental condition	7
4.6.	Statement of the measurement uncertainty	8
4.7.	Equipment Used during the Test	9
<b>5.</b>	<b>TEST CONDITIONS AND RESULTS</b>	<b>11</b>
5.1.	Antenna Requirement	11
5.2.	Digital Modulation Techniques	12
5.3.	Automatic discontinuation of transmission	13
5.4.	Peak Output Power	14
5.5.	Emission Bandwidth B	16
5.6.	Power Spectral Density	18
5.7.	In-Band Unwanted Emissions, Conducted	22
5.8.	Out-of-Band Unwanted Emissions, Conducted	24
5.9.	Carrier Frequency Stability	31
5.10.	Frame Repetition Stability	32
5.11.	Frame Period and Jitter	33
5.12.	Monitoring Threshold, Least Interfered Channel	34
5.13.	Threshold Monitoring Bandwidth	36
5.14.	Reaction Time and Monitoring Interval	37
5.15.	Time and Spectrum Window Access Procedure	38
5.16.	Acknowledgements and Transmission Duration	40
5.17.	Dual Access Criteria Check	42
5.18.	Radiated Spurious Emission	43
5.19.	AC Conducted Emission	48
<b>6.</b>	<b>TEST SETUP PHOTOS</b>	<b>50</b>
<b>7.</b>	<b>EXTERNAL AND INTERNAL PHOTOS</b>	<b>50</b>

# 1. TEST STANDARDS AND REPORT VERSION

## 1.1. Test Standards

The tests were performed according to following standards:

- [FCC Rules Part 15D](#): Unlicensed Personal Communications Service Devices
- [ANSI C63.17:2013](#): American National Standard Methods of Measurement of the Electromagnetic and Operational Compatibility of Unlicensed Personal Communications Services (UPCS) Devices

## 1.2. Report version

Revision No.	Date of issue	Description
N/A	2022-11-18	Original

## 2. TEST DESCRIPTION

Report clause	Test Items	Standard Requirement	Result	Test Engineer
5.1	Antenna Requirement	15.203/15.317	PASS	Xiaoqin Li
5.2	Digital modulation techniques	15.319(b)	PASS	Xiaoqin Li
5.3	Automatic discontinuation of transmission	15.319(f)	PASS	Xiaoqin Li
5.4	Peak transmit power and antenna gain	15.319(c)(e); 15.31(e)	PASS	Xiaoqin Li
5.5	Emission bandwidth B	15.323(a)	PASS	Xiaoqin Li
5.6	Power spectral density	15.319(d)	PASS	Xiaoqin Li
5.7	In-band unwanted emissions	15.323(d)	PASS	Xiaoqin Li
5.8	Out-of-band unwanted emissions	15.323(d)	PASS	Xiaoqin Li
5.9	Carrier frequency stability	15.323(f)	PASS	Xiaoqin Li
5.10	Frame repetition stability	15.323(e)	PASS	Xiaoqin Li
5.11	Frame period and jitter	15.323(e)	PASS	Xiaoqin Li
5.12	Monitoring threshold, Least interfered channel	15.323(c)(2)(5)(9)	PASS	Xiaoqin Li
5.13	Threshold monitoring bandwidth	15.323(c)(7)	PASS	Xiaoqin Li
5.14	Reaction time and monitoring interval	15.323(c)(1)(5)(7)	PASS	Xiaoqin Li
5.15	Time and Spectrum Window Access Procedure	15.323(c)(4)(6)	PASS	Xiaoqin Li
5.16	Acknowledgements and Transmission duration	15.323(c) (3) (4)	PASS	Xiaoqin Li
5.17	Dual access criteria check	15.323(c)(10)	PASS	Xiaoqin Li
5.18	Radiated Spurious Emission	15.319(g); 15.209	PASS	Quanhai Deng
5.19	AC Conducted Emission	15.207	PASS	Dongyang Wu

**Note:**

- The measurement uncertainty is not included in the test result.

### 3. SUMMARY

#### 3.1. Client Information

Applicant:	YEALINK(XIAMEN) NETWORK TECHNOLOGY CO.,LTD.
Address:	No.666 Hu' an Rd,Huli District Xiamen City, Fujian, P.R. China
Manufacturer:	YEALINK(XIAMEN) NETWORK TECHNOLOGY CO.,LTD.
Address:	No.666 Hu' an Rd,Huli District Xiamen City, Fujian, P.R. China

#### 3.2. Product Description

Main unit information:	
Product Name:	HD Wireless Conference Phone
Trade Mark:	YEALINK
Model No.:	CP935W
Listed Model(s):	-
Power supply:	Rechargeable battery DC3.7V, 7800mAh, charged by adapter
Hardware version:	-
Software version:	-
Accessory unit information:	
Adapter information:	Adapter No.: YLPS121250C1-3C Input: AC100-240V; 50/60Hz; 0.5A Output: DC12.0V 1.25A
Cable(s):	DC cable: 250cm unshielded DC cable: 85cm unshielded USB Type C cable: 85cm unshielded

#### 3.3. Radio Specification Description

Terminal type:	<input checked="" type="checkbox"/> FP <input type="checkbox"/> PP <input type="checkbox"/> HyP (hibrid part) <input type="checkbox"/> CTA (cordless terminal adaptor) <input type="checkbox"/> WRS (wireless relay station)
Frequency range:	1921.536 to 1928.448 MHz
Number of channels:	5 RF Channels, 5 × 12 = 60 TDMA Duplex Channels
Modulation:	Digital (Gaussian Frequency Shift Keying)
Antenna Connector:	None
Number of Antennas:	1
Antenna Diversity Supported:	No
Antenna gain:	5.81dBi

### 3.4. Testing Laboratory Information

Laboratory Name	Shenzhen Huatongwei International Inspection Co., Ltd.	
Laboratory Location	1/F, Bldg 3, Hongfa Hi-tech Industrial Park, Genyu Road, Tianliao, Gongming, Shenzhen, China	
Connect information:	Phone: 86-755-26715499 E-mail: <a href="mailto:cs@szhtw.com.cn">cs@szhtw.com.cn</a> <a href="http://www.szhtw.com.cn">http://www.szhtw.com.cn</a>	
Qualifications	Type	Accreditation Number
	FCC	762235

## 4. TEST CONFIGURATION

### 4.1. Test frequency list

According to section 15.31(m), regards to the operating frequency range over 10 MHz, must select three channels which were tested. The Lowest frequency, the middle frequency, and the highest frequency of channel were selected to perform the test, please see the below blue front.

Channel	Frequency (MHz)
0	1928.448
1	1926.720
2	1924.992
3	1923.264
4	1921.536

### 4.2. Descriptions of Test mode

Transmitting mode	Keep the EUT in continuously communicating mode with radio tester.
-------------------	--

### 4.3. Test sample information

Test item	HTW sample no.
RF Conducted test items	YPHT21121122001
RF Radiated test items	YPHT21121122001
EMI test items	YPHT21121122001

Note:

RF Conducted test items: Peak Output Power, Power Spectral Density, 6dB Bandwidth, 99% Occupied Bandwidth, Duty cycle, Conducted Band edge and Spurious Emission

RF Radiated test items: Radiated Band Edge Emission, Radiated Spurious Emission

EMI test items: AC Conducted Emission

### 4.4. Support unit used in test configuration and system

The EUT has been associated with peripherals and configuration operated in a manner tended to maximize its emission characteristics in a typical application.

The following peripheral devices and interface cables were connected during the measurement:

Whether support unit is used?			
✓ No			
Item	Equipment	Trade Name	Model No.
1			
2			

### 4.5. Testing environmental condition

Type	Requirement	Actual
Temperature:	15~35°C	25°C
Relative Humidity:	25~75%	50%
Air Pressure:	860~1060mbar	1000mbar

#### 4.6. Statement of the measurement uncertainty

Test Item	Measurement Uncertainty
AC Conducted Emission (150kHz~30MHz)	3.21 dB
Radiated Emission (30MHz~1000MHz)	4.54 dB
Radiated Emissions (1GHz~25GHz)	5.10 dB
Peak Output Power	1.07dB
Power Spectral Density	1.07dB
Conducted Spurious Emission	1.07dB
6dB Bandwidth	0.002%

This uncertainty represents an expanded uncertainty expressed at approximately the 95% confidence level using a coverage factor of  $k=1.96$ .



#### 4.7. Equipment Used during the Test

● Conducted Emission							
Used	Test Equipment	Manufacturer	Equipment No.	Model No.	Serial No.	Last Cal. Date (YY-MM-DD)	Next Cal. Date (YY-MM-DD)
●	Shielded Room	Albatross projects	HTWE0114	N/A	N/A	2018/09/28	2023/09/27
●	EMI Test Receiver	R&S	HTWE0111	ESCI	101247	2022/08/30	2023/08/29
●	Artificial Mains	SCHWARZBECK	HTWE0113	NNLK 8121	573	2022/08/29	2023/08/28
●	Pulse Limiter	R&S	HTWE0193	ESH3-Z2	101447	2022/08/29	2023/08/28
●	RF Connection Cable	HUBER+SUHNER	HTWE0113-02	ENVIROFLE X 142	EF-NM-BNCM-2M	2022/09/17	2023/09/16
●	Test Software	R&S	N/A	ES-K1	N/A	N/A	N/A

● Radiated emission-6th test site							
Used	Test Equipment	Manufacturer	Equipment No.	Model No.	Serial No.	Last Cal. Date (YY-MM-DD)	Next Cal. Date (YY-MM-DD)
●	Semi-Anechoic Chamber	Albatross projects	HTWE0127	SAC-3m-02	C11121	2018/09/30	2023/09/29
●	EMI Test Receiver	R&S	HTWE0099	ESCI	100900	2022/08/30	2023/08/29
●	Loop Antenna	R&S	HTWE0170	HFH2-Z2	100020	2021/04/06	2024/04/05
●	Ultra-Broadband Antenna	SCHWARZBECK	HTWE0123	VULB9163	538	2021/04/06	2024/04/05
●	Pre-Amplifier	SCHWARZBECK	HTWE0295	BBV 9742	N/A	2021/11/05	2022/11/04
●	Pre-Amplifier	SCHWARZBECK	HTWE0295	BBV 9742	N/A	2022/11/04	2023/11/03
●	RF Connection Cable	HUBER+SUHNER	HTWE0062-01	N/A	N/A	2022/02/25	2023/02/24
●	RF Connection Cable	HUBER+SUHNER	HTWE0062-02	SUCOFLEX104	501184/4	2022/02/25	2023/02/24
●	Test Software	R&S	N/A	ES-K1	N/A	N/A	N/A

● Radiated emission-7th test site							
Used	Test Equipment	Manufacturer	Equipment No.	Model No.	Serial No.	Last Cal. Date (YY-MM-DD)	Next Cal. Date (YY-MM-DD)
●	Semi-Anechoic Chamber	Albatross projects	HTWE0122	SAC-3m-01	C11121	2018/09/27	2023/09/26
●	Spectrum Analyzer	R&S	HTWE0098	FSP40	100597	2022/08/25	2023/08/24
●	Horn Antenna	SCHWARZBECK	HTWE0126	9120D	1011	2020/04/01	2023/03/31
●	Broadband Horn Antenna	SCHWARZBECK	HTWE0103	BBHA9170	BBHA9170472	2020/04/27	2023/04/26
●	Pre-amplifier	CD	HTWE0071	PAP-0102	12004	2021/11/05	2022/11/04
●	Pre-amplifier	CD	HTWE0071	PAP-0102	12004	2022/11/04	2023/11/03
●	Broadband Pre-amplifier	SCHWARZBECK	HTWE0201	BBV 9718	9718-248	2022/02/28	2023/02/27
●	RF Connection Cable	HUBER+SUHNER	HTWE0120-01	6m 18GHz S Serisa	N/A	2022/02/25	2023/02/24
●	RF Connection Cable	HUBER+SUHNER	HTWE0120-02	6m 3GHz RG Serisa	N/A	2022/02/25	2023/02/24
●	RF Connection Cable	HUBER+SUHNER	HTWE0119-05	6m 3GHz RG Serisa	N/A	2022/02/25	2023/02/24
●	RF Connection Cable	HUBER+SUHNER	HTWE0120-04	6m 3GHz RG Serisa	N/A	2022/02/25	2023/02/24
●	Test Software	Audix	N/A	E3	N/A	N/A	N/A

Used	Test Equipment	Manufacturer	Model No.	Serial No.	Last Cal. Date (YY-MM-DD)	Next Cal. Date (YY-MM-DD)
●	Signal and spectrum Analyzer	R&S	FSV40	100048	2022/08/25	2023/08/24
●	Signal & Spectrum Analyzer	R&S	FSW26	103440	2022/08/25	2023/08/24
●	Spectrum Analyzer	Agilent	N9020A	MY50510187	2022/08/25	2023/08/24
●	Radio communication tester	R&S	CMD60		2022/08/25	2023/08/24

## **5. TEST CONDITIONS AND RESULTS**

### **5.1. Antenna Requirement**

#### **REQUIREMENT**

##### **FCC CFR Title 47 Part 15 Subpart C Section 15.203, 15.317**

An intentional radiator shall be designed to ensure that no antenna other than that furnished by the responsible party shall be used with the device. The use of a permanently attached antenna or of an antenna that uses a unique coupling to the intentional radiator, the manufacturer may design the unit so that a broken antenna can be replaced by the user, but the use of a standard antenna jack or electrical connector is prohibited.

#### **TEST RESULT**

**Passed**       **Not Applicable**

The antenna type is a FPC Antenna, please refer to Appendix\_ Internal photos.

## 5.2. Digital Modulation Techniques

### REQUIREMENT

#### **FCC CFR Title 47 Part 15 Subpart D Section 15.319(b)**

All transmissions must use only digital modulation techniques

### TEST RESULT

**Passed**       **Not Applicable**

The EUT uses Multi Carrier / Time Division Multiple Access / Time Division Duplex and Digital GFSK modulation. For further details see the operational description provided by the applicant.

### 5.3. Automatic discontinuation of transmission

#### **REQUIREMENT**

##### **FCC CFR Title 47 Part 15 Subpart D Section 15.319(f)**

The device shall automatically discontinue transmission in case of either absence of information to transmit or operational failure. These provisions are not intended to preclude transmission of control and signaling information or use of repetitive codes used by certain digital technologies to complete frame or burst intervals

#### **TEST RESULT**

**Passed**       **Not Applicable**

The following tests simulate the reaction of the EUT in case of either absence of information to transmit or operational failure after a connection with the companion device is established.

No.	Test	EUT Reaction	Verdict
1	Power removed from EUT	A	Pass
2	Switch off EUT	N/A	Pass
3	Hook-on by EUT	A	Pass
4	Power removed from companion device	B	Pass
5	Switch off companion device	B	Pass
6	Hook-on by companion device	B	Pass

A - Connection breakdown, Cease of all transmissions

B - Connection breakdown, EUT transmits control and signaling information

C - Connection breakdown, Companion Device transmits control and signaling information

N/A - Not Applicable (EUT/Companion Device does not have On/Off switch and cannot perform Hook-On)

Note: For more information please refer to declaration letter.

## 5.4. Peak Output Power

### LIMIT

#### FCC CFR Title 47 Part 15 Subpart C Section 15.319 (c)(e):

Peak transmit power shall not exceed 100 microwatts multiplied by the square root of the emission bandwidth in Hertz.

The peak transmit power shall be reduced by the amount in decibels that the maximum directional gain of the antenna exceeds 3dBi.

### TEST CONFIGURATION

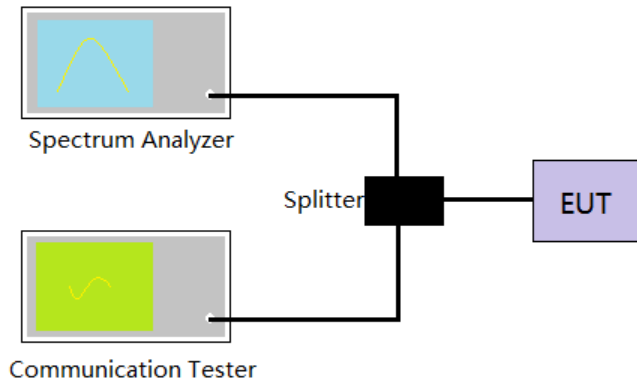

### TEST PROCEDURE

RBW  $\geq$  Emission bandwidth, Video bandwidth  $\geq$  RBW

Center frequency: Nominal center frequency of transmit carrier

Span: Zero

Amplitude scale: Log (linear may be used if analyzer has sufficient linear dynamic range and accuracy)

Detection: Peak detection

Trigger: Video

Sweep rate: Sufficiently rapid to permit the transmit pulse to be resolved accurately

### TEST MODE

Please refer to the clause 4.2

### TEST RESULT

Passed  Not Applicable

### TEST DATA

Test channel	Measurement data (dBm)	Limit (dBm)	Result
CH <sub>L</sub>	18.98	20.38	Pass
CH <sub>M</sub>	19.02	20.40	Pass
CH <sub>H</sub>	18.91	20.37	Pass

Limit= 100uW x SQRT (B), where B is the measured Emission Bandwidth in Hz

CH<sub>L</sub>

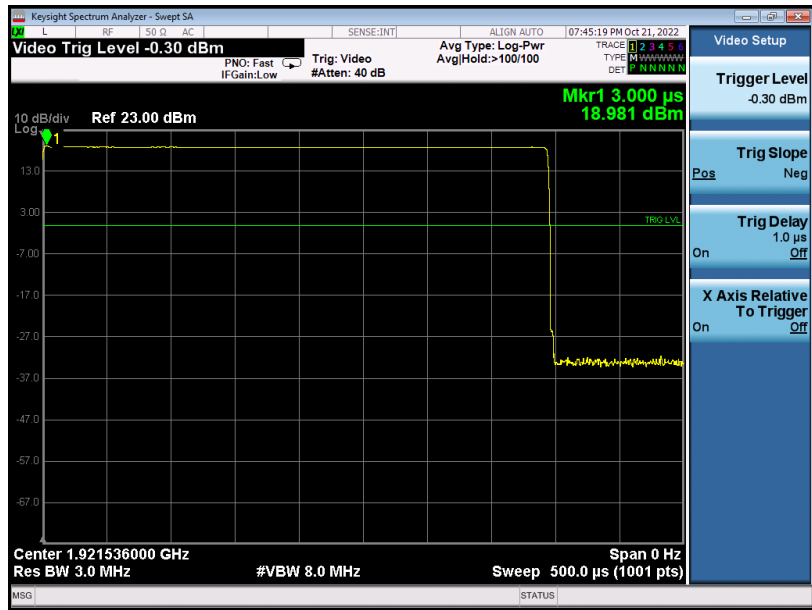

CH<sub>M</sub>

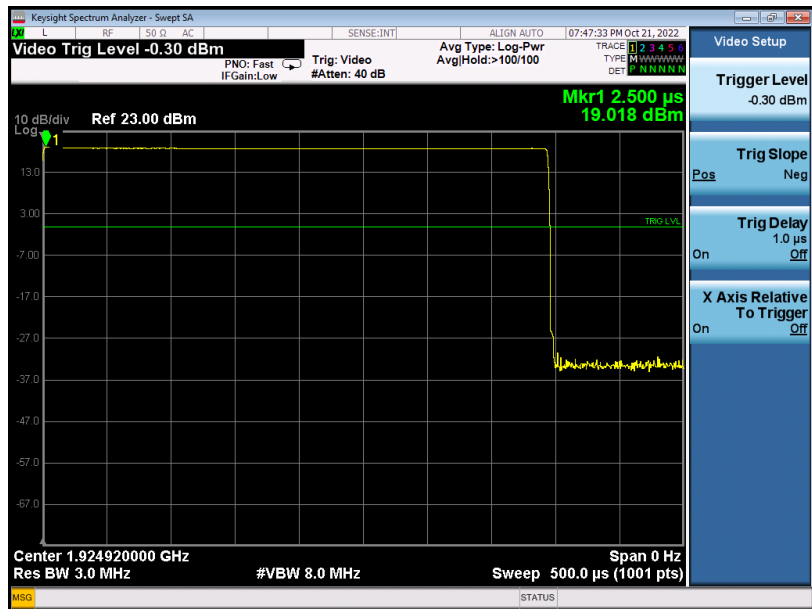

CH<sub>H</sub>

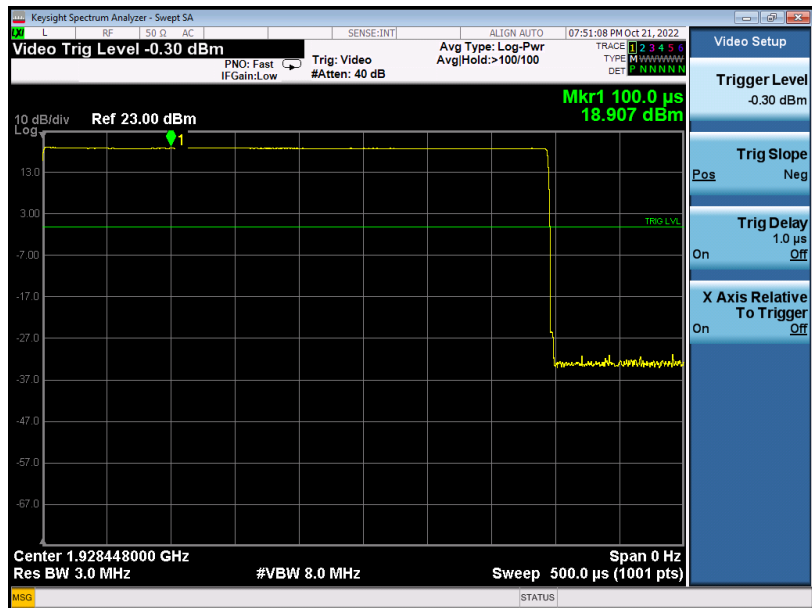

## 5.5. Emission Bandwidth B

### LIMIT

#### FCC CFR Title 47 Part 15 Subpart C Section 15.323 (a):

The Emission Bandwidth B shall be larger than 50 kHz and less than 2.5 MHz

No requirements for 6 and 12dB Bandwidth, these values are only used for testing Monitoring Bandwidth if the Simple Compliance test fails (ANSI C63.17, clause 7.4).

### TEST CONFIGURATION

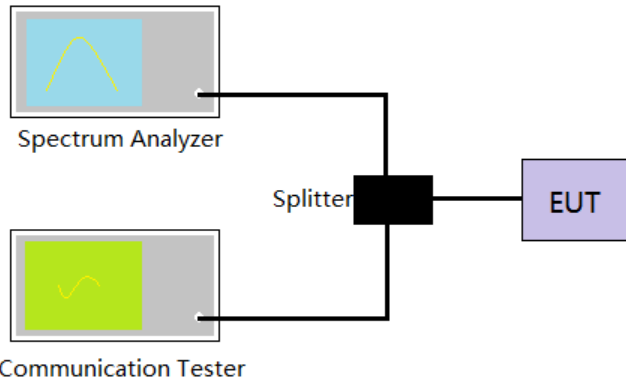

### TEST PROCEDURE

RBW: Approximately 1% of the emission bandwidth (a rough estimate may be obtained from peak power level measurement, or use manufacturer's declared value),

Video bandwidth  $\geq 3 \times$  the RBW

Center frequency: Nominal center frequency of transmit carrier

Span:  $\geq 2 \times$  the expected emission bandwidth

Amplitude scale: Log (linear may be used if analyzer has sufficient linear dynamic range and accuracy)

Detection: Peak detection with maximum hold enabled

Sweep rate: Coupled to frequency span and RBW

### TEST MODE

Please refer to the clause 4.2

### TEST RESULT

Passed  Not Applicable

### TEST DATA

Test channel	Measurement data (MHz)	Limit	Result
CH <sub>L</sub>	1.193	>50kHz, <2.5MHz	Pass
CH <sub>M</sub>	1.202		Pass
CH <sub>H</sub>	1.186		Pass



CH<sub>L</sub>



CH<sub>M</sub>



CH<sub>H</sub>



## 5.6. Power Spectral Density

### LIMIT

#### FCC CFR Title 47 Part 15 Subpart D Section 15.319 (d):

Power spectral density shall not exceed 3 milliwatts in any 3 kHz bandwidth as measured with a spectrum analyzer having a resolution bandwidth of 3 kHz

### TEST CONFIGURATION

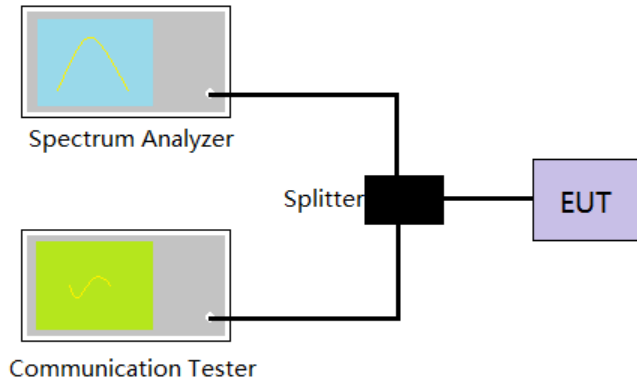

### TEST PROCEDURE

RBW: 3kHz

Video bandwidth  $\geq 3 \times$  the RBW

Center frequency: Nominal center frequency of transmit carrier

Span:  $\geq 2 \times$  the expected emission bandwidth

Amplitude scale: Log (linear may be used if analyzer has sufficient linear dynamic range and accuracy)

Detection: Sample detection and averaged for a minimum of 100 sweeps

Sweep rate: For burst signals, sufficient to include essentially all of the maximum length burst at the output of a 3 kHz filter (e.g., maximum input burst duration plus 600  $\mu$ s). For continuous signals, 20 ms.

### TEST MODE

Please refer to the clause 4.2

### TEST RESULT

Passed  Not Applicable

### TEST DATA

Test channel	Measurement data (dBm/3kHz)	Limit	Result
CH <sub>L</sub>	-1.275	4.8dBm/3kHz	Pass
CH <sub>M</sub>	-1.433		
CH <sub>H</sub>	-1.666		

CHL

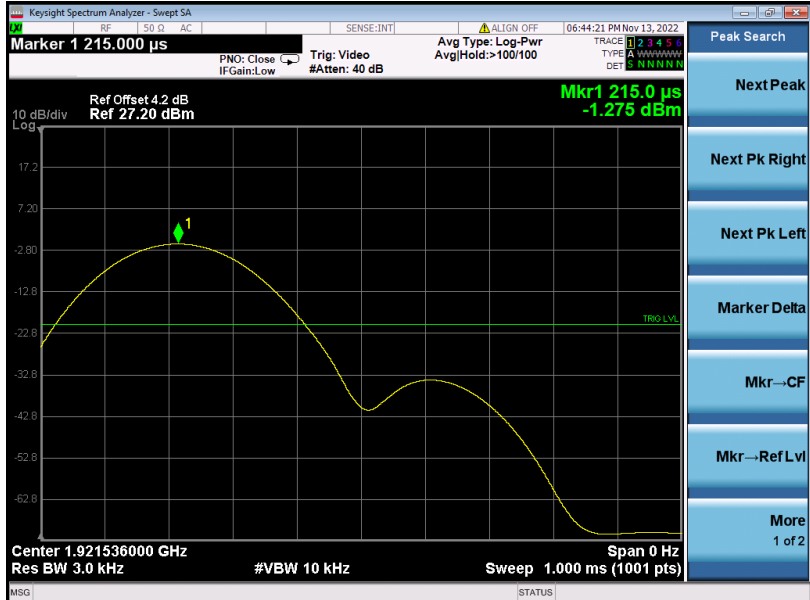

CHM

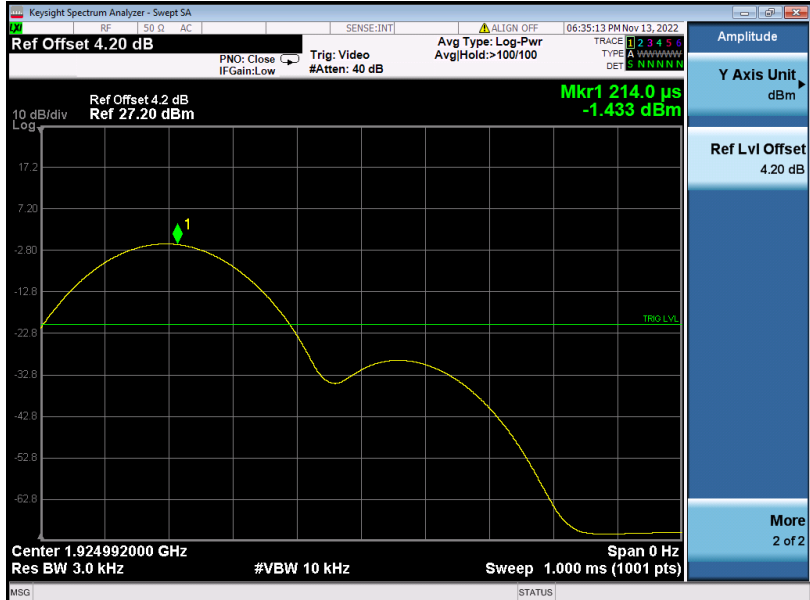

CH<sub>H</sub>

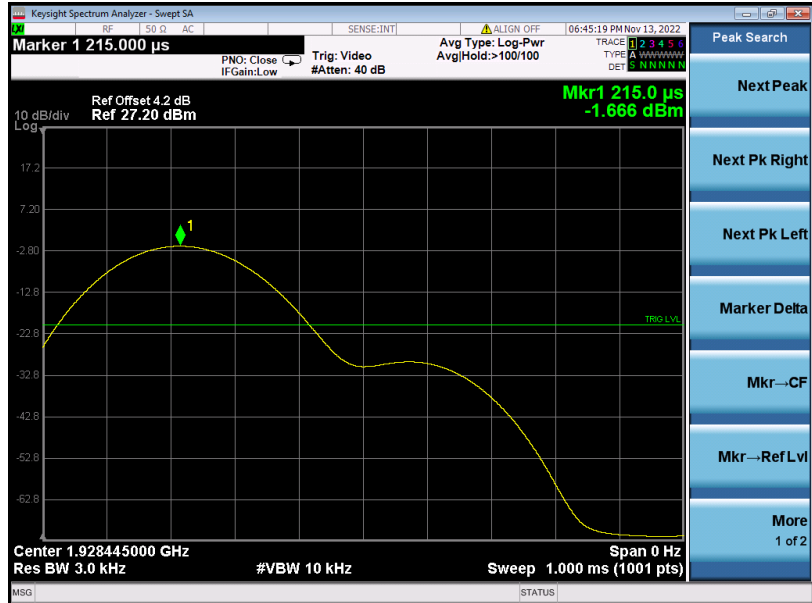

## 5.7. In-Band Unwanted Emissions, Conducted

### LIMIT

**FCC CFR Title 47 Part 15 Subpart D Section 15.323 (d):**

$B < f \leq 2B$ : at least 30 dB below max. permitted peak power

$2B < f \leq 3B$ : at least 50 dB below max. permitted peak power

$3B < f \leq$  UPCS Band Edge: at least 60 dB below max. permitted peak power

### TEST CONFIGURATION

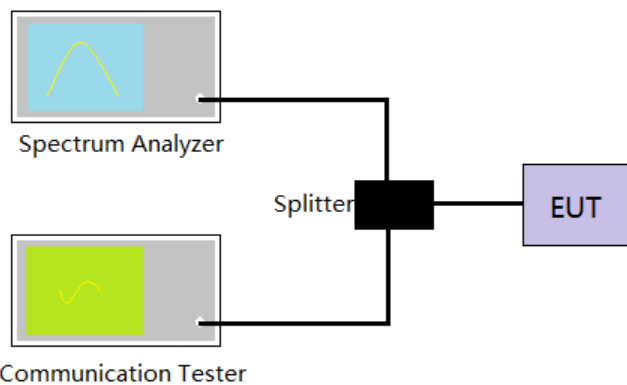

### TEST PROCEDURE

RBW: Approximately 1% of the emission bandwidth (B)

Video bandwidth  $\geq 3 \times$  the RBW

Center frequency: Nominal center frequency of transmit carrier

Span: Approximately equal to  $3.5 B$

Amplitude scale: Log

Detection: Peak detection and max hold enabled

Sweep time: The sweep time shall be sufficiently slow that the swept frequency rate shall not exceed one RBW per three transmit bursts

Number of sweeps: Sufficient to stabilize the trace

### TEST MODE

Please refer to the clause 4.2

### TEST RESULT

Passed       Not Applicable

### TEST DATA

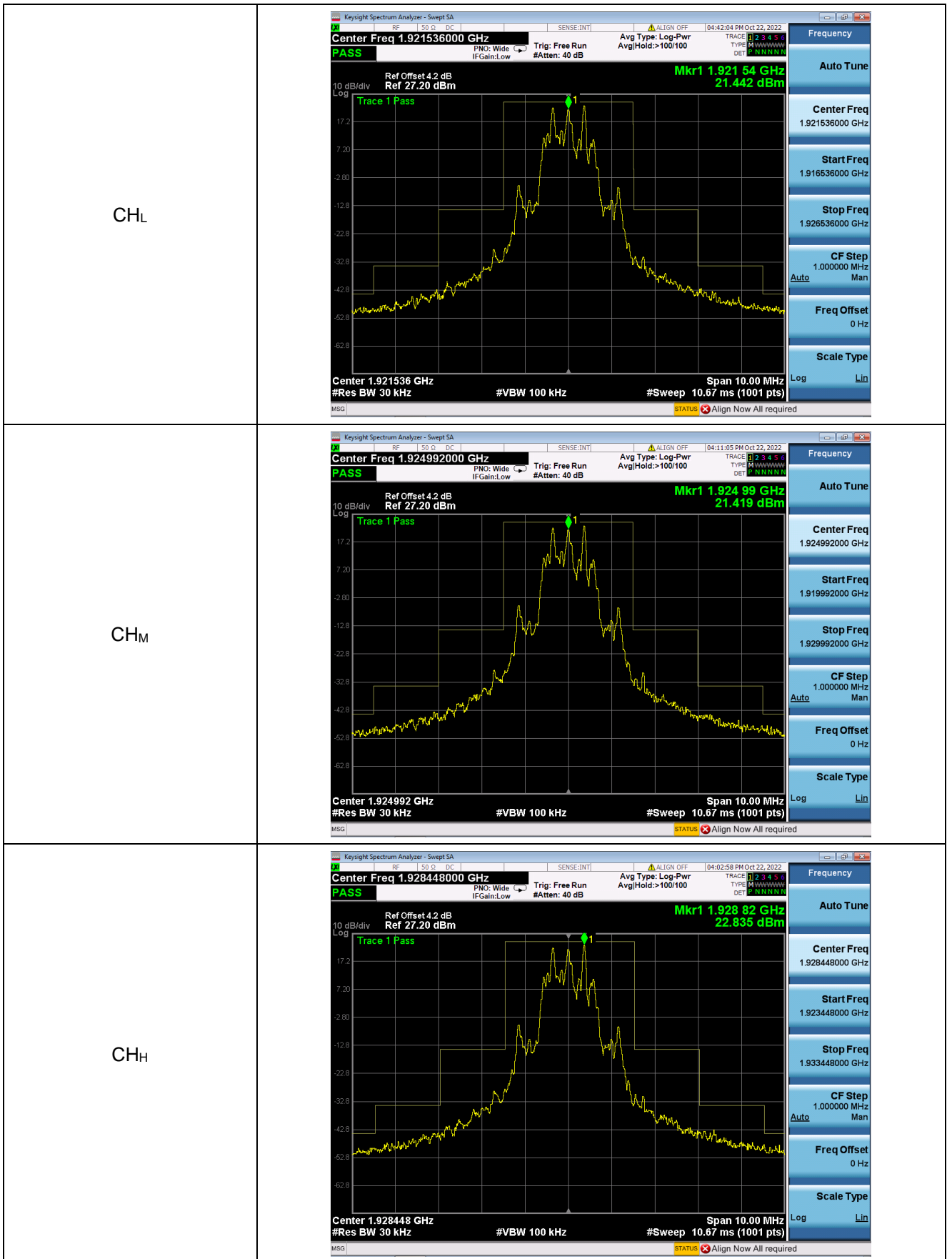

## 5.8. Out-of-Band Unwanted Emissions, Conducted

### LIMIT

FCC CFR Title 47 Part 15 Subpart D Section 15.323 (d):

$f \leq 1.25\text{MHz}$  outside UPCS band:  $\leq -9.5\text{dBm}$

$1.25\text{MHz} \leq f \leq 2.5\text{MHz}$  outside UPCS band:  $\leq -29.5\text{ dBm}$

$f \geq 2.5\text{MHz}$  outside UPCS band:  $\leq -39.5\text{ dBm}$

### TEST CONFIGURATION

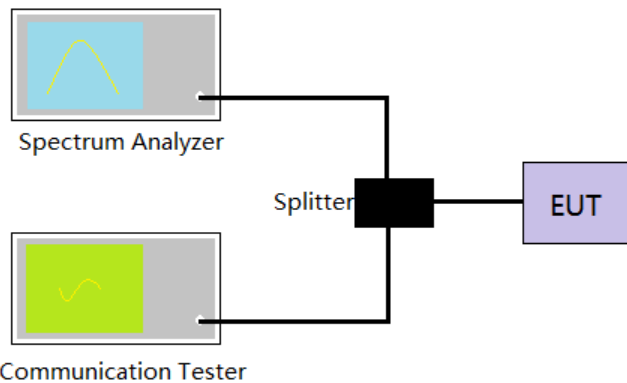

### TEST PROCEDURE

RBW: Approximately 1% of the emission bandwidth (B)

Video bandwidth  $\geq 3 \times$  the RBW

Center frequency: Nominal center frequency of transmit carrier

Span: Approximately equal to  $3.5 B$

Amplitude scale: Log

Detection: Peak detection and max hold enabled

Sweep time: The sweep time shall be sufficiently slow that the swept frequency rate shall not exceed one RBW per three transmit bursts.

Number of sweeps: Sufficient to stabilize the trace

### TEST MODE

Please refer to the clause 4.2

### TEST RESULT

Passed  Not Applicable

### TEST DATA



CHL

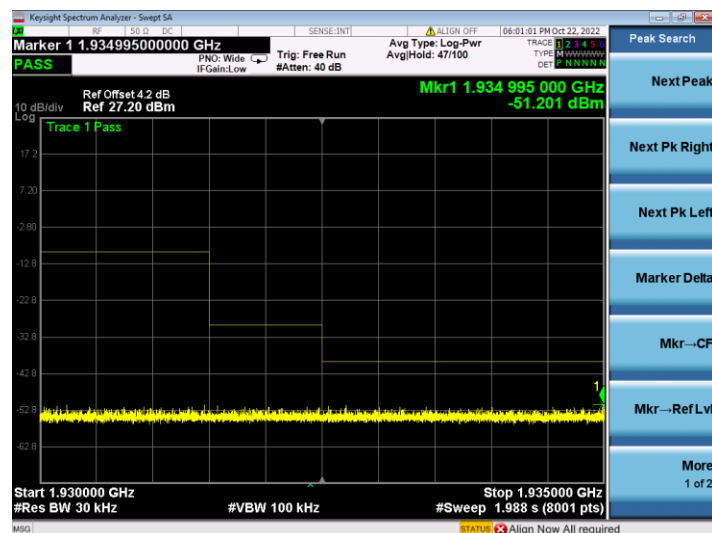
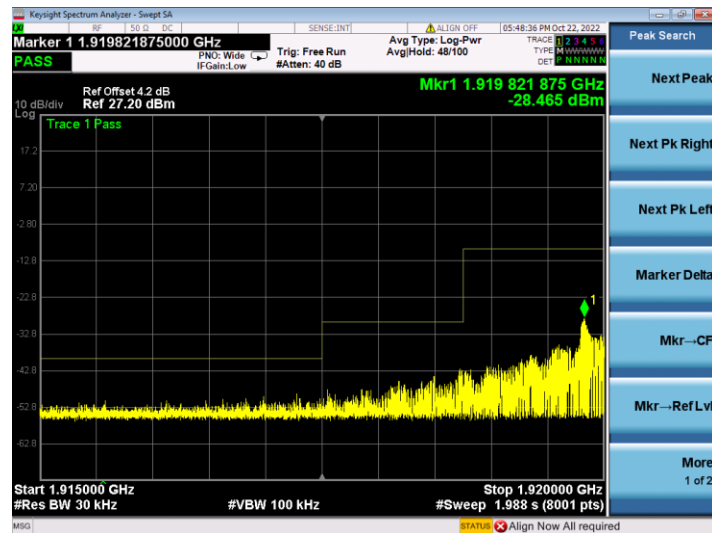
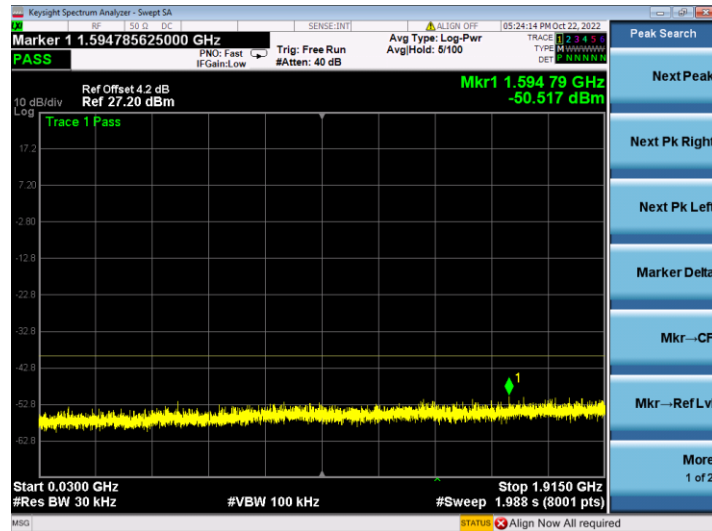

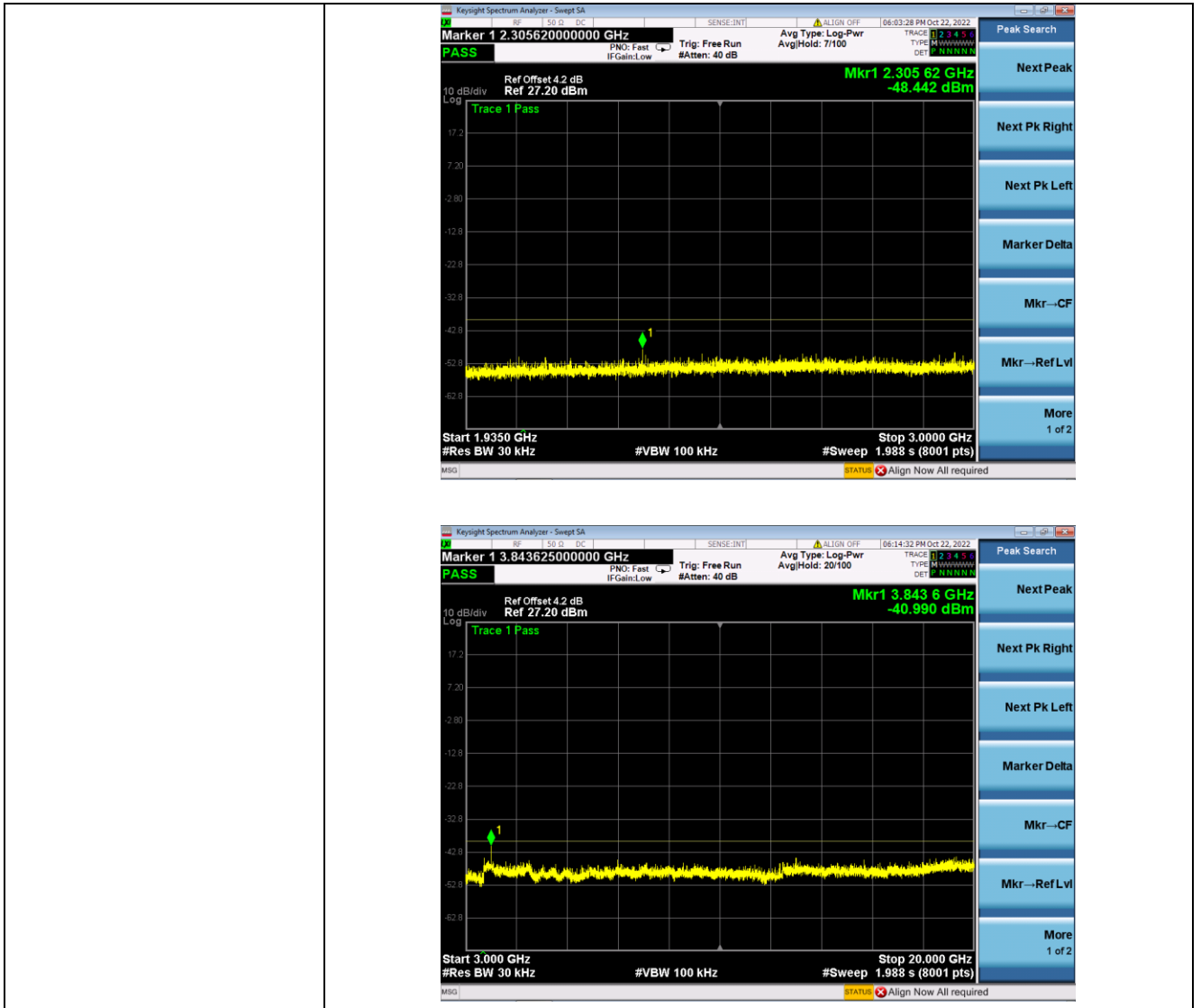

CH<sub>M</sub>

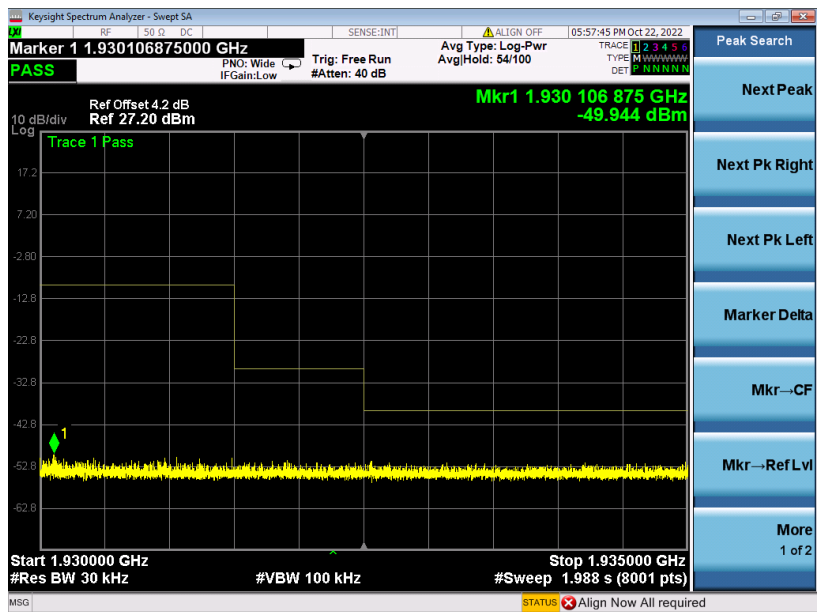
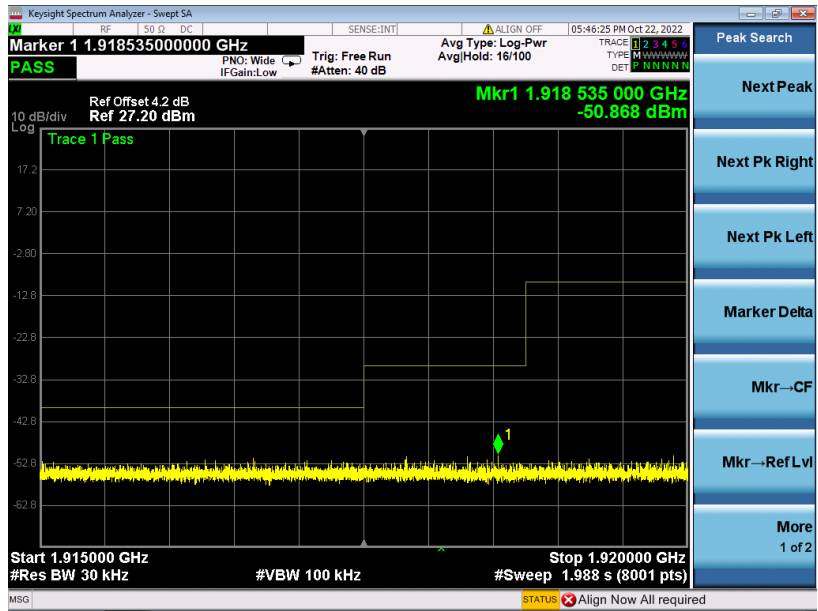
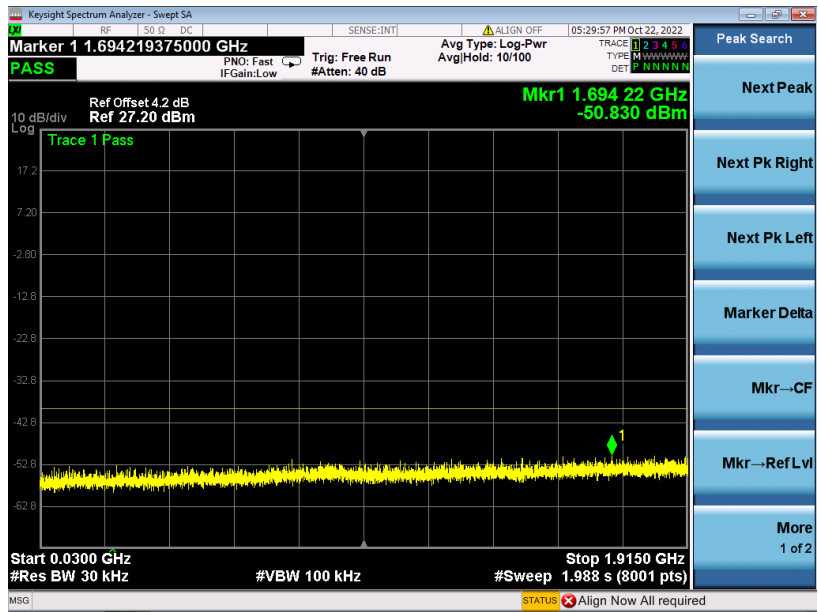

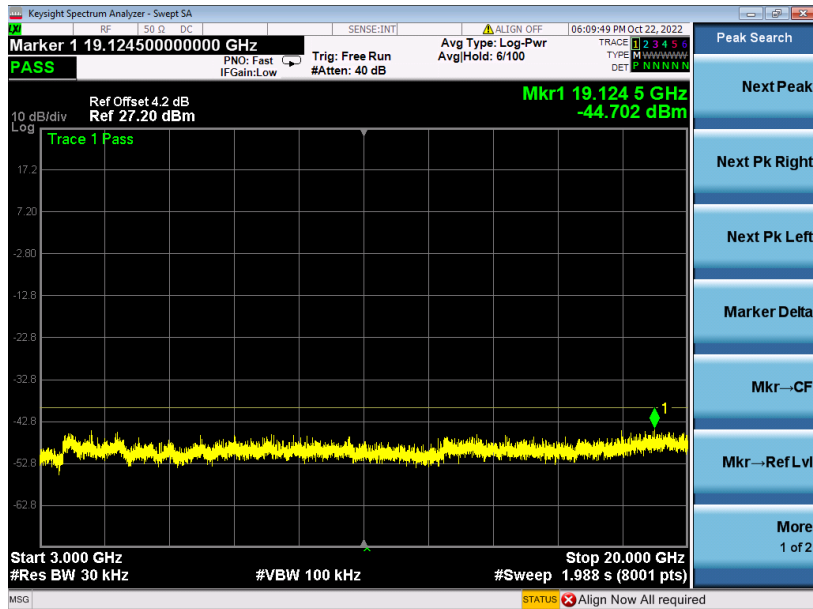
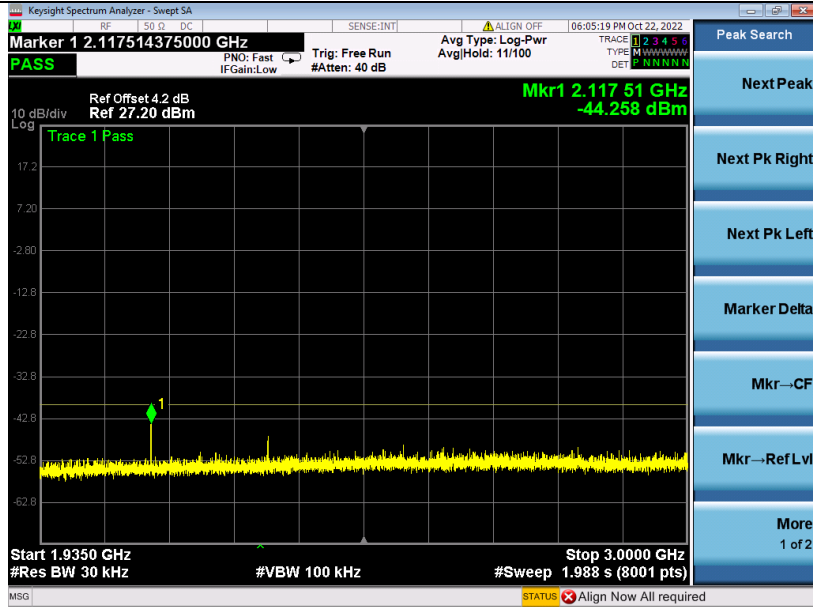

CH<sub>H</sub>

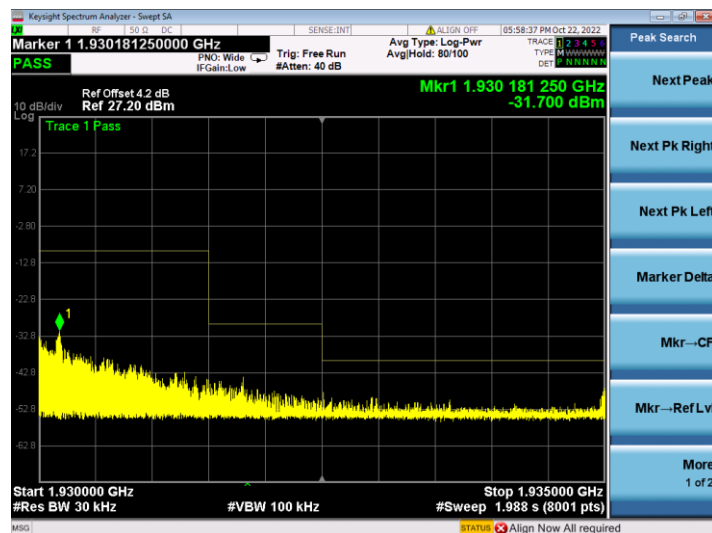
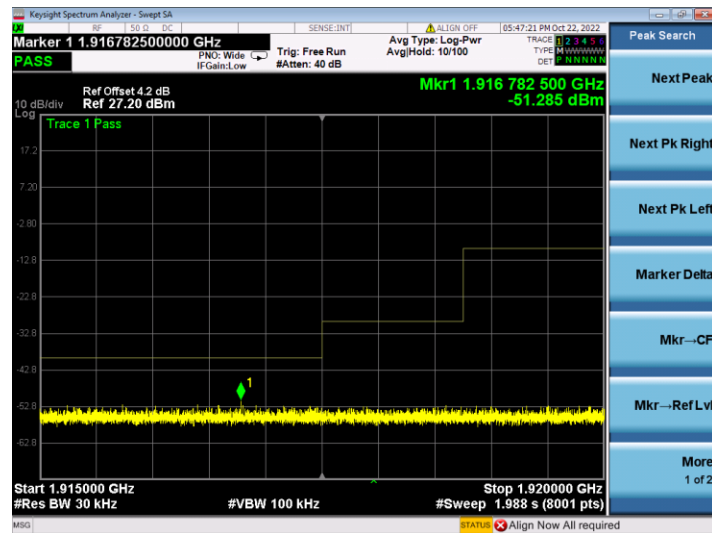
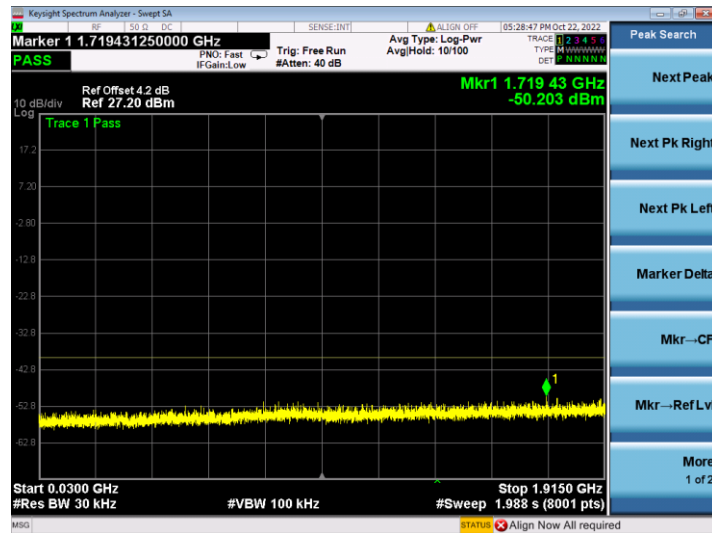

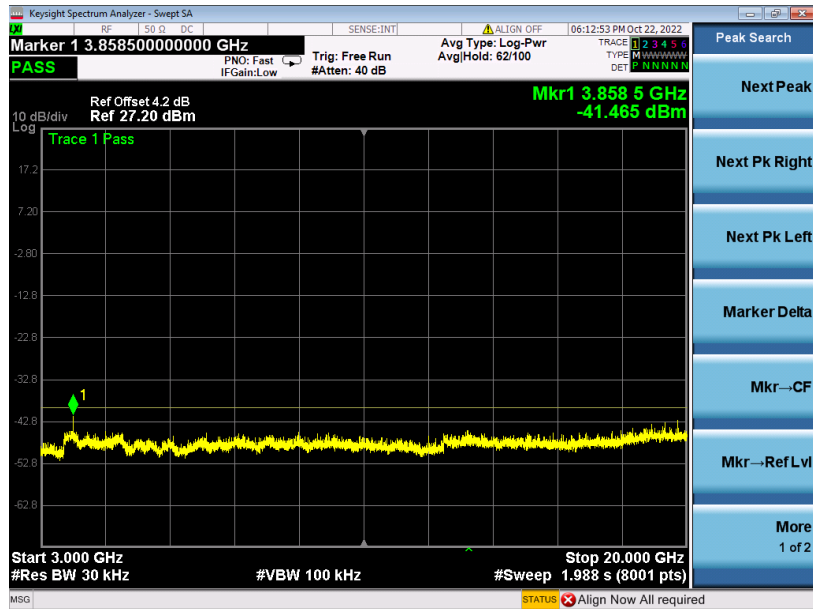
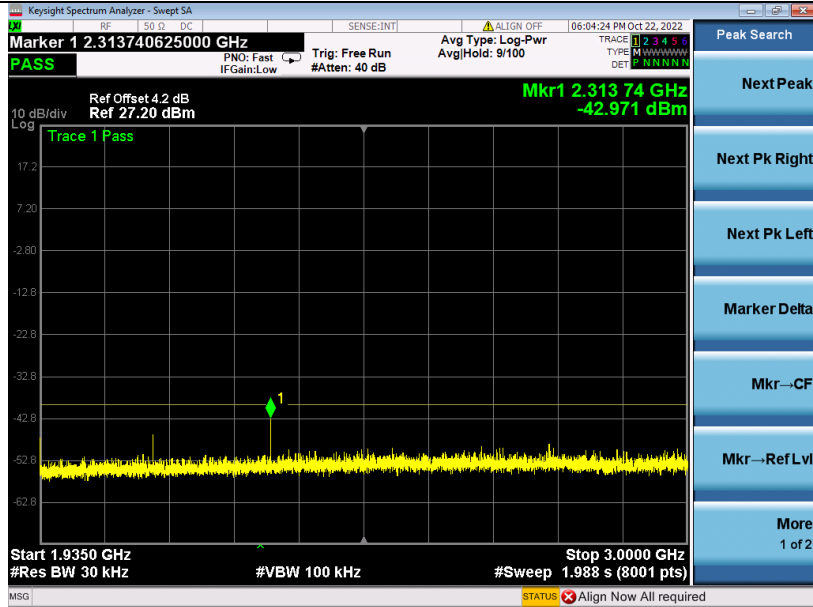

## 5.9. Carrier Frequency Stability

### LIMIT

#### FCC CFR Title 47 Part 15 Subpart D Section 15.323 (f):

Maintained within +/-10 ppm at the following conditions:

1. Over 1 hour at nominal supply voltage and a temperature of +20 °C;
2. Over a variation in the primary supply voltage of 85 % to 115 % of nominal supply voltage at a temperature of +20 °C. This test does not apply to an EUT that is only powered by battery for operation;
3. Over a temperature variation of -20 °C to +50 °C or at extreme temperatures as declared by manufacturer, and at nominal supply voltage

### TEST CONFIGURATION

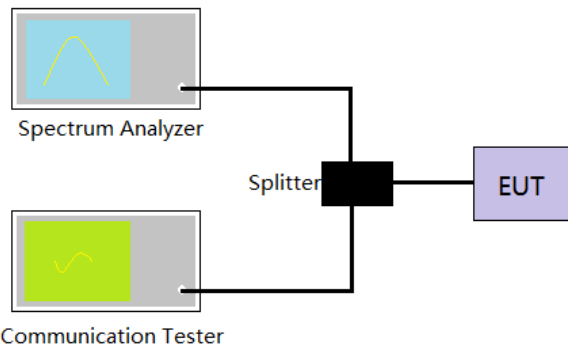

### TEST PROCEDURE

Measurements are made in accordance with ANSI C63.17 sub-clause 6.2.1

The EUT and CMD60 is connected with shielded coaxial cable.

The EUT is controlled by DECT Radio Communication Tester, CMD60, to use a fixed frequency channel during test as well as record the frequency offset. The transmission of EUT is in burst mode with pseudo-random data.

### TEST MODE

Please refer to the clause 4.2

### TEST RESULT

Passed  Not Applicable

### TEST DATA

Carrier Frequency Stability over time at nominal temperature:

Average mean carrier frequency (MHz)	Max. Diff. (kHz)	Min. Diff. (kHz)	Max. Dev. (ppm)	Limit (ppm)	Result
1924.991687	0.56	-0.48	0.54	±10	Pass

Temp	Voltage	Measured carrier frequency (MHz)	Difference (kHz)	Deviation (ppm)	Limit (ppm)	Result
25°C	V <sub>nom</sub>	1924.992	0.0	0.0	±10	Pass
	85% of V <sub>nom</sub>	1924.992	0.0	0.0	±10	Pass
	115% of V <sub>nom</sub>	1924.992	0.0	0.0	±10	Pass
-20°C	V <sub>nom</sub>	1924.992	0.0	0.0	±10	Pass
+50°C	V <sub>nom</sub>	1924.992	0.0	0.0	±10	Pass

## 5.10. Frame Repetition Stability

### LIMIT

#### FCC CFR Title 47 Part 15 Subpart D Section 15.323 (e):

TDD: EUT that implement time division for the purpose of maintaining a duplex connection shall maintain a frame-repetition rate whereby three times the standard deviation of the frequency stability shall not exceed 50 ppm, not including a shift of the mean;

TDMA: EUT that further divides access in time shall maintain a frame-repetition rate whereby three times the standard deviation of the frequency stability shall not exceed 10 ppm, not including a shift of the mean.

### TEST CONFIGURATION

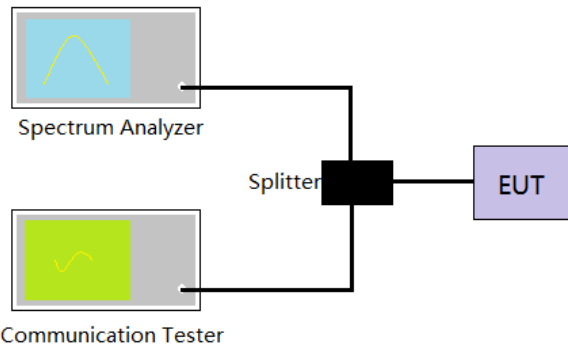

### TEST PROCEDURE

X axis: Time

Time setting: Approximate frame period  $\times$  100

Y axis: Frequency

Center frequency: Nominal frame-repetition rate

Frequency span: Span large enough so that the full waveform is greater than 50% but less than 100% of the display scale

Measurement time interval (gating time) :X (in units of frame period) where  $X \leq 1000$

Number of measurements:  $1000/X$  (where X is the measurement interval in units of frame period)

### TEST MODE

Please refer to the clause 4.2

### TEST RESULT

Passed  Not Applicable

### TEST DATA

Carrier frequency (MHz)	Maximum Frame Repetition Stability (ppm)	Limit (ppm)	Result
1924.992	<0.0001 and >-0.0001	$\pm 10$	Pass



## 5.11. Frame Period and Jitter

### LIMIT

FCC CFR Title 47 Part 15 Subpart D Section 15.323 (e):

Frame Period: 20 or 10ms

Max Jitter: 25us

3 times St.Dev of Jitter: 12.5us

### TEST CONFIGURATION

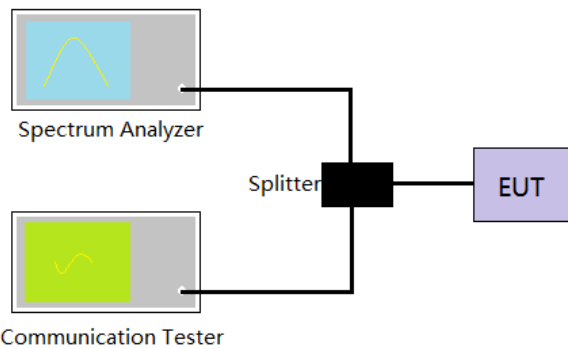

### TEST PROCEDURE

Measurements are made in accordance with ANSI C63.17 sub-clause 6.2.3.

A spectrum analyzer measures the time duration between the rising edges of two consecutive frames.

The measurements are taken over 100,000 frames.

These measurement values are used to compute mean value and the difference between any two consecutive frame periods. The mean value is the frame period.

### TEST MODE

Please refer to the clause 4.2

### TEST RESULT

Passed       Not Applicable

### TEST DATA

Carrier frequency (MHz)	Measured Maximum Jitter (μs)	Limit (μs)	Results
1924.992	-0.186	±25	Pass

## 5.12. Monitoring Threshold, Least Interfered Channel

### LIMIT

#### FCC CFR Title 47 Part 15 Subpart D Section 15.323(c)(2)(5)(9):

Least Interfered Channel Procedure (LIC) may only be used by systems with more than 20 duplex system access channels.

Systems with less than 20 duplex system access channels are not allowed to transmit when interferer level is above Lower Threshold.

### TEST CONFIGURATION

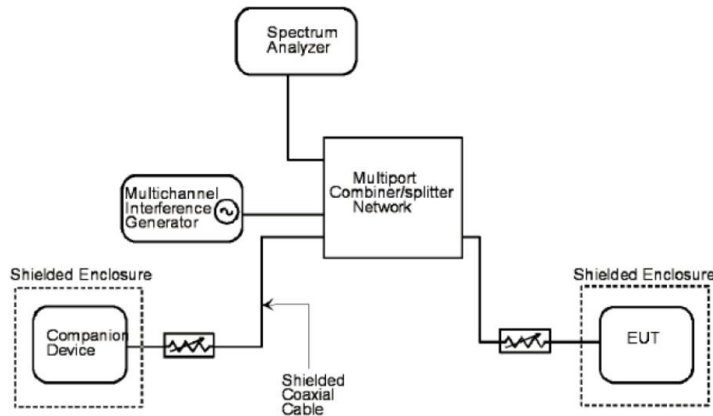

### TEST PROCEDURE

Please refer to accordance with ANSI C63.17 Clause 7.3.1, 7.3.3, 7.3.4.

### TEST MODE

Please refer to the clause 4.2

### TEST RESULT

Passed       Not Applicable

### TEST DATA

#### Calculation of Monitoring Threshold Limit:

$$\begin{aligned} \text{Monitoring Threshold (T)} &\leq -174 + 10 \log_{10} B + M + P_{\max} - P_{\text{EUT}} \text{ dBm} \\ &\leq 15 \log_{10} B - 184 + M - P_{\text{EUT}} \text{ dBm} \end{aligned}$$

Where B = Measured Emission Bandwidth

M = 30 dB for Lower Monitoring Threshold (T<sub>L</sub>), or  
= 50 dB for Upper Monitoring Threshold (T<sub>U</sub>)

P<sub>max</sub> = 5 log<sub>10</sub> B – 10 dBm

P<sub>EUT</sub> = Measured Peak Transmit Power

Lower Monitoring Threshold (TL + UM) in dBm	-81.82
Upper Monitoring Threshold (TU + UM) in dBm	-61.82

**Test Descriptions and Results:**

Least Interfered Channel (LIC) Procedure Test, FCC 15.323(b), (c)(2) and (c)(5)

ANSI C63.17 clause 7.3.2 ref.	Observation	Result
b) f1 at TL + UM + 7 dB, f2 at TL + UM	Transmission always on f2	Pass
c) f1 at TL + UM, f2 at TL + UM +7 dB	Transmission always on f1	Pass
d) f1 at TL + UM + 1 dB, f2 at TL + UM - 6 dB	Transmission always on f2	Pass
e) f1 at TL + UM - 6 dB, f2 at TL + UM + 1 dB	Transmission always on f1	Pass

Selected Channel Confirmation, FCC 15.323(c)(1) and (5)

ANSI C63.17 clause 7.3.3	Observation	Result
b) Shall not transmit on f1	EUT transmits on f2	Pass
d) Shall not transmit on f2	EUT transmits on f1	Pass

### 5.13. Threshold Monitoring Bandwidth

#### LIMIT

#### FCC CFR Title 47 Part 15 Subpart D Section 15.323(c)(7)

The monitoring system bandwidth must be equal to or greater than the emission bandwidth of the intended transmission.

#### TEST CONFIGURATION

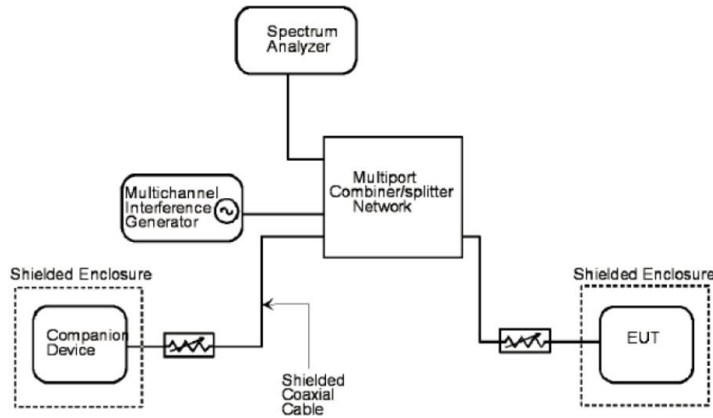

#### TEST PROCEDURE

Please refer to accordance with ANSI C63.17 Clause 7.4.1

#### TEST MODE

Please refer to the clause 4.2

#### TEST RESULT

Passed       Not Applicable

#### TEST DATA

Test performed	Observation	Result
Simple Compliance test, at $\pm 30\%$ of B	N/A	N/A
More Detailed Test, at $\pm 6$ dB points	N/A	N/A
More Detailed Test, at $\pm 12$ dB points	N/A	N/A

N/A – Not applicable

\*Remarks: Detailed Compliance Test was used to show the compliance of the EUT.

## 5.14. Reaction Time and Monitoring Interval

### LIMIT

#### FCC CFR Title 47 Part 15 Subpart D Section 15.323(c) (1) (5) (7)

The maximum reaction time must be required to be less than 50  $\mu\text{s}$ . If a signal is detected that is 6 dB or more above the applicable threshold level, the maximum reaction time shall not be required to be less than 35  $\mu\text{s}$ .

### TEST CONFIGURATION

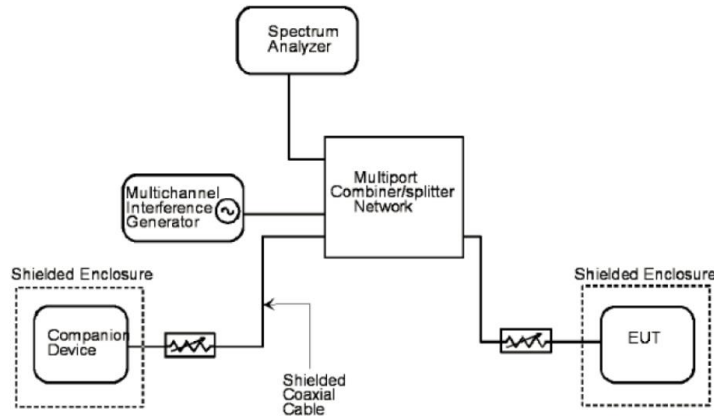

### TEST PROCEDURE

Please refer to accordance with ANSI C63.17 Clause 7.5

### TEST MODE

Please refer to the clause 4.2

### TEST RESULT

Passed       Not Applicable

### TEST DATA

Pulse Width, ref. to ANSI C63.17 clause 7.5	Observation	Result
c) > largest of 50 $\mu\text{s}$	EUT transmits on f1	Pass
d) > largest of 35 $\mu\text{s}$	EUT transmits on f1	Pass

Comment: Since B is larger than 1.25 MHz the test was performed with pulse lengths of 50  $\mu\text{s}$  and 35  $\mu\text{s}$ .

## 5.15. Time and Spectrum Window Access Procedure

### LIMIT

#### FCC CFR Title 47 Part 15 Subpart D Section 15.323(c) (4) (6)

Once access to specific combined time and spectrum windows is obtained an acknowledgment from a system participant must be received by the initiating transmitter within one second or transmission must cease. Periodic acknowledgments must be received at least every 30 seconds or transmission must cease. Channels used exclusively for control and signaling information may transmit continuously for 30 seconds without receiving an acknowledgment, at which time the access criteria must be repeated.

If the selected combined time and spectrum windows are unavailable, the device may either monitor and select different windows or seek to use the same windows after waiting an amount of time, randomly chosen from a uniform random distribution between 10 and 150 milliseconds, commencing when the channel becomes available.

### TEST CONFIGURATION

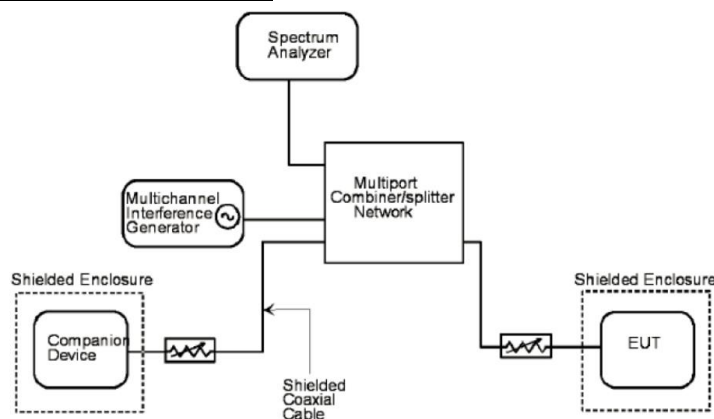

### TEST PROCEDURE

Please refer to accordance with ANSI C63.17 Clause 8.1.1, 8.2.1; 8.1.2 or 8.1.3.

### TEST MODE

Please refer to the clause 4.2

### TEST RESULT

Passed  Not Applicable

### TEST DATA

Access Criteria, ref. to ANSI C63.17 clause 8.1.1, 8.2.1	Observation	Result
b) Check that the EUT transmits on the interference free time-slot	EUT transmits on the interference free time-slot	Pass
b) The EUT must terminate or pause in its repetitive transmission of the control and signalling channel on the open channel to repeat the access criteria not less frequently than every 30 s	Transmission paused every 1.08 s	Pass

If FCC 15.323(c)(6) option, If Random Waiting Interval is NOT implemented

Access Criteria, ref. to ANSI C63.17 clause 8.1.2	Observation	Result
b) Check that the EUT changes to an interference-free slot when interference is introduced on the time slot in use	EUT changes to the interference-free time-slot, and stays there	Pass

If FCC 15.323(c)(6) option, Only if Random Waiting Interval is implemented

Access Criteria, ref. to ANSI C63.17 clause 8.1.3	Observation	Result
b-d) Check that the EUT uses random waiting interval before continuing transmission on an interfered time slot	N/A	N/A

Comment: The tested EUT does not support the Random Waiting Interval option.

## 5.16. Acknowledgements and Transmission Duration

### LIMIT

#### **FCC CFR Title 47 Part 15 Subpart D Section 15.323(c) (3) (4)**

Occupation of the same combined time and spectrum windows by a device or group of cooperating devices continuously over a period of time longer than 8 hours is not permitted without repeating the access criteria.

Once access to specific combined time and spectrum windows is obtained an acknowledgement from a system participant must be received by the initiating transmitter within one second or transmission must cease.

Periodic acknowledgements must be received at least every 30 seconds or transmission must cease.

Channels used exclusively for control and signaling information may transmit continuously for 30 seconds without receiving an acknowledgement, at which time the access criteria must be repeated.

### TEST CONFIGURATION

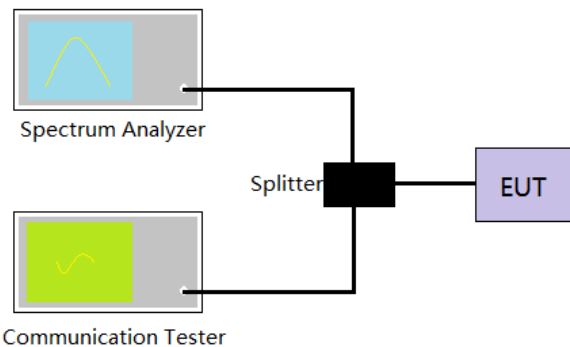

### TEST PROCEDURE

Please refer to accordance with ANSI C63.17 Clause 8.2

### TEST MODE

Please refer to the clause 4.2

### TEST RESULT

Passed  Not Applicable

### TEST DATA



Timing for EUTs using control and signaling channel type transmissions:

Conditions	Transmission Duration (seconds)	Limit (seconds)	Result
Time needed to repeat access criteria	NA	30	Pass

Timing for EUTs using communications channel type transmissions:

Conditions	Transmission Duration (seconds)	Limit (seconds)	Result
Activate EUT w/ companion device off	NA	1	NA
Time needed to cease Traffic Channel	4.9	30	Pass

Transmission Duration

Measured Maximum Transmission Duration (minutes)	Limit (seconds)	Result
330	480	Pass

## 5.17. Dual Access Criteria Check

### LIMIT

#### FCC CFR Title 47 Part 15 Subpart D Section 15.323(c) (10)

An initiating device may attempt to establish a duplex connection by monitoring both its intended transmit and receive time and spectrum windows. If both the intended transmit and receive time and spectrum windows meet the access criteria, then the initiating device can initiate a transmission in the intended transmit time and spectrum window. If the power detected by the responding device can be decoded as a duplex connection signal from the initiating device, then the responding device may immediately begin transmitting on the receive time and spectrum window monitored by the initiating device.

### TEST CONFIGURATION

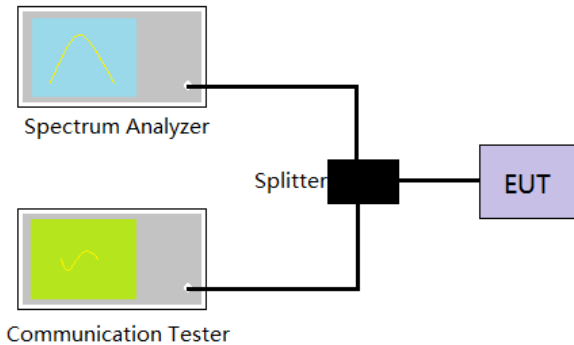

### TEST PROCEDURE

Please refer to accordance with ANSI C63.17 Clause 8.3

### TEST MODE

Please refer to the clause 4.2

### TEST RESULT

Passed  Not Applicable

### TEST DATA

If FCC 15.323(c)(6) option, Only if Random Waiting Interval is implemented

Test ref. to ANSI C63.17 clause 8.3.2	Observation	Result
b) EUT is restricted to a single carrier f1 for TDMA systems. The Test is Pass if EUT can transmit	EUT can transmit	Pass
c) d) Transmission on interference-free receive time/spectrum window	EUT transmits on interference free receive slot	Pass
e) f) Transmission on interference-free transmit time/spectrum window	EUT transmits on interference free transmit slot	Pass

### 5.18. Radiated Spurious Emission

#### LIMIT

#### FCC CFR Title 47 Part 15 Subpart C Section 15.209

Frequency	Limit (dBuV/m)	Value
0.009 MHz ~0.49 MHz	2400/F(kHz) @300m	Quasi-peak
0.49 MHz ~ 1.705 MHz	24000/F(kHz) @30m	Quasi-peak
1.705 MHz ~30 MHz	30 @30m	Quasi-peak

Note: Limit dBuV/m @3m = Limit dBuV/m @300m + 40\*log(300/3)= Limit dBuV/m @300m +80,

Limit dBuV/m @3m = Limit dBuV/m @30m +40\*log(30/3)= Limit dBuV/m @30m + 40.

Frequency	Limit (dBuV/m @3m)	Value
30MHz~88MHz	40.00	Quasi-peak
88MHz~216MHz	43.50	Quasi-peak
216MHz~960MHz	46.00	Quasi-peak
960MHz~1GHz	54.00	Quasi-peak
Above 1GHz	54.00	Average
	74.00	Peak

#### TEST CONFIGURATION

- 9 kHz ~ 30 MHz

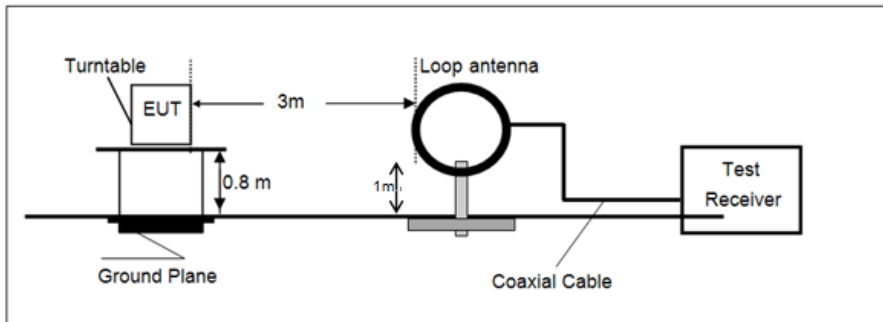

- 30 MHz ~ 1 GHz

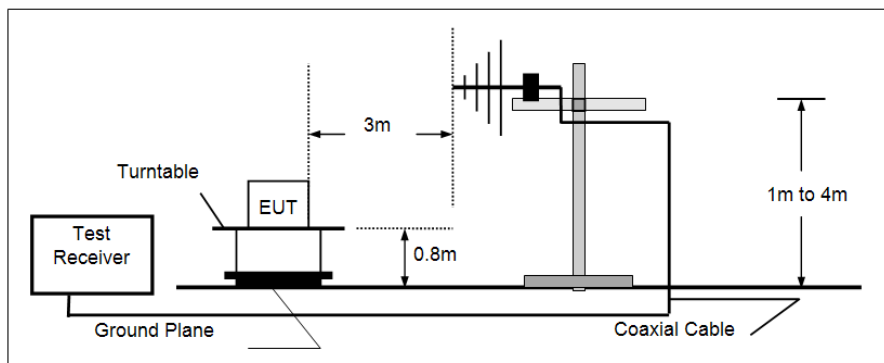

- Above 1 GHz

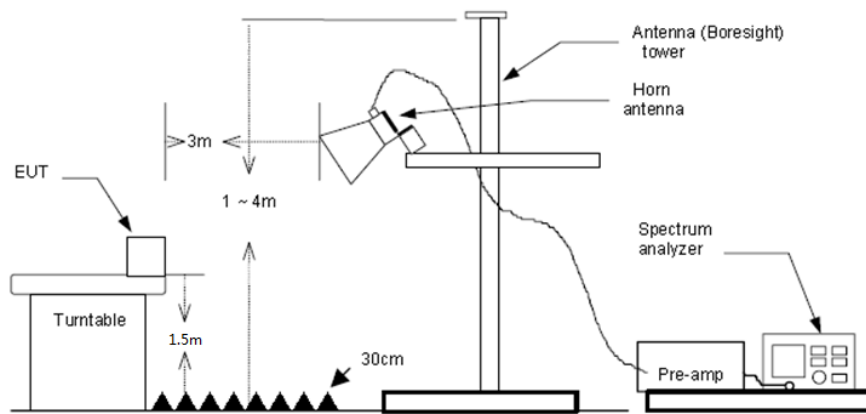

### **TEST PROCEDURE**

1. The EUT was setup and tested according to ANSI C63.10 .
2. The EUT is placed on a turn table which is 0.8 meter above ground for below 1 GHz, and 1.5 m for above 1 GHz. The turn table is rotated 360 degrees to determine the position of the maximum emission level.
3. The EUT was set 3 meters from the receiving antenna, which was mounted on the top of a variable height antenna tower.
4. For each suspected emission, the EUT was arranged to its worst case and then tune the Antenna tower (from 1 m to 4 m) and turntable (from 0 degree to 360 degrees) to find the maximum reading. A pre-amp and a high pass filter are used for the test in order to get better signal level to comply with the guidelines.
5. Set to the maximum power setting and enable the EUT transmit continuously.
6. Use the following spectrum analyzer settings
  - a) Span shall wide enough to fully capture the emission being measured;
  - b) Below 1 GHz:
    - RBW=120 kHz, VBW=300 kHz, Sweep=auto, Detector function=peak, Trace=max hold;
    - If the emission level of the EUT measured by the peak detector is 3 dB lower than the applicable limit, the peak emission level will be reported. Otherwise, the emission measurement will be repeated using the quasi-peak detector and reported.
  - c) Set RBW=1MHz, VBW=3MHz for >1GHz, Sweep time=auto, Detector=peak, Trace=max hold for Peak measurement
    - For average measurement:
      - VBW=10Hz, When duty cycle is no less than 98 percent
      - $VBW \geq 1/T$ , when duty cycle is less than 98 percent where T is the minimum transmission duration over which the transmitter is on and is transmitting at its maximum power control level for the tested mode of operation, so refer to this clause 5.6 duty cycle.

### **TEST MODE**

Please refer to the clause 4.2

### **TEST RESULT**

**Passed**       **Not Applicable**

Note:

- 1) Level= Reading + Factor/Transd; Factor/Transd =Antenna Factor+ Cable Loss- Preamp Factor
- 2) Over Limit = Level– Limit
- 3) Average measurement was not performed if peak level is lower than average limit(54 dBuV/m) for above 1GHz.

**For 9 kHz ~ 30 MHz**

The EUT was pre-scanned this frequency band, found the radiated level 20dB lower than the limit, so don't show data on this report.

**For 30 MHz ~ 1000 MHz**

Have pre-scan all test channel, found CH<sub>L</sub> which it was worst case, so only show the worst case's data on this report.

Polarization:

Horizontal

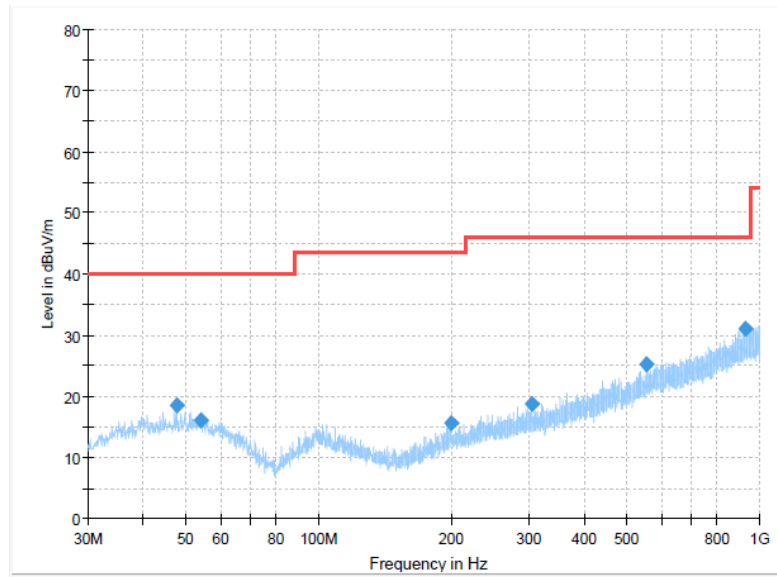

**Final Result**

Frequency (MHz)	MaxPeak (dBuV/m)	Limit (dBuV/m)	Margin (dB)	Height (cm)	Pol	Azimuth (deg)	Corr. (dB/m)
47.702500	18.61	40.00	21.39	100.0	H	79.0	-9.3
54.007500	16.06	40.00	23.94	100.0	H	137.0	-9.5
199.507500	15.64	43.50	27.86	100.0	H	90.0	-10.3
304.995000	18.67	46.00	27.33	100.0	H	295.0	-7.4
552.223750	25.17	46.00	20.83	100.0	H	255.0	-0.4
931.615000	31.03	46.00	14.97	100.0	H	355.0	6.7

Polarization:

Vertical

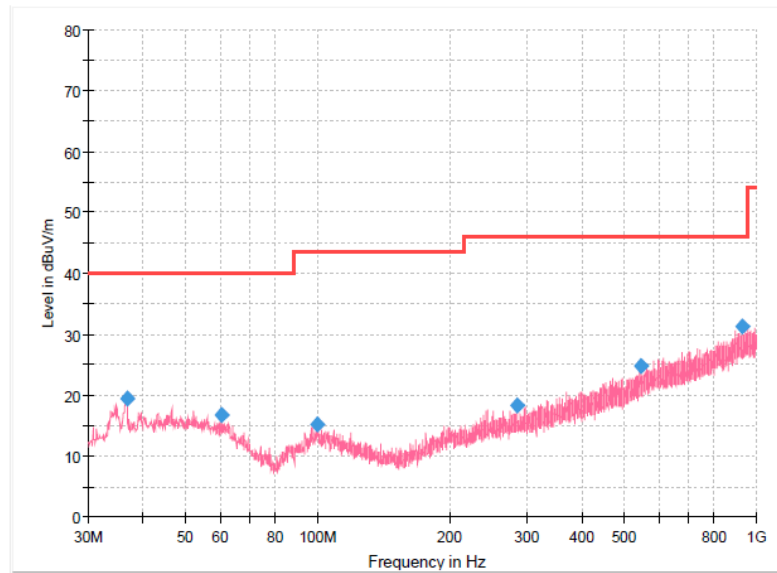

**Final Result**

Frequency (MHz)	MaxPeak (dBuV/m)	Limit (dBuV/m)	Margin (dB)	Height (cm)	Pol	Azimuth (deg)	Corr. (dB/m)
36.790000	19.43	40.00	20.57	100.0	V	207.0	-10.6
60.555000	16.73	40.00	23.27	100.0	V	119.0	-10.2
100.203750	15.14	43.50	28.36	100.0	V	167.0	-10.8
285.110000	18.36	46.00	27.64	100.0	V	338.0	-8.1
545.191250	24.89	46.00	21.11	100.0	V	90.0	-0.6
931.857500	31.32	46.00	14.68	100.0	V	0.0	6.8

**For 1 GHz ~ 25 GHz**

Test channel		CH <sub>L</sub>			Polarity		Horizontal		
Mark	Frequency MHz	Reading dBuV/m	Antenna dB	Cable dB	Preamp dB	Level dBuV/m	Limit dBuV/m	Over limit	Remark
1	1179.10	52.02	25.52	2.75	36.67	43.62	74.00	-30.38	Peak
2	2750.08	47.39	28.20	4.21	37.24	42.56	74.00	-31.44	Peak
3	5104.74	38.13	32.18	5.92	35.48	40.75	74.00	-33.25	Peak
4	10885.67	35.13	40.56	9.10	36.76	48.03	74.00	-25.97	Peak

Test channel		CH <sub>L</sub>			Polarity		Vertical		
Mark	Frequency MHz	Reading dBuV/m	Antenna dB	Cable dB	Preamp dB	Level dBuV/m	Limit dBuV/m	Over limit	Remark
1	1179.10	53.59	25.52	2.75	36.67	45.19	74.00	-28.81	Peak
2	2947.62	51.45	28.70	4.49	37.41	47.23	74.00	-26.77	Peak
3	5797.03	37.36	31.99	6.74	34.86	41.23	74.00	-32.77	Peak
4	10917.18	35.16	40.60	9.11	36.74	48.13	74.00	-25.87	Peak

Test channel		CH <sub>M</sub>			Polarity		Horizontal		
Mark	Frequency MHz	Reading dBuV/m	Antenna dB	Cable dB	Preamp dB	Level dBuV/m	Limit dBuV/m	Over limit	Remark
1	1179.94	51.97	25.52	2.75	36.67	43.57	74.00	-30.43	Peak
2	2754.19	48.16	28.22	4.21	37.24	43.35	74.00	-30.65	Peak
3	4834.05	37.81	31.40	5.76	35.20	39.77	74.00	-34.23	Peak
4	9784.47	36.03	39.60	8.44	36.17	47.90	74.00	-26.10	Peak

Test channel		CH <sub>M</sub>			Polarity		Vertical		
Mark	Frequency MHz	Reading dBuV/m	Antenna dB	Cable dB	Preamp dB	Level dBuV/m	Limit dBuV/m	Over limit	Remark
1	1179.94	53.25	25.52	2.75	36.67	44.85	74.00	-29.15	Peak
2	2950.14	49.79	28.70	4.50	37.41	45.58	74.00	-28.42	Peak
3	5034.99	37.51	32.11	5.84	35.34	40.12	74.00	-33.88	Peak
4	11312.31	35.03	40.42	9.34	36.48	48.31	74.00	-25.69	Peak

Test channel		CH <sub>H</sub>			Polarity		Horizontal		
Mark	Frequency MHz	Reading dBuV/m	Antenna dB	Cable dB	Preamp dB	Level dBuV/m	Limit dBuV/m	Over limit	Remark
1	1179.94	50.47	25.52	2.75	36.67	42.07	74.00	-31.93	Peak
2	2754.19	49.79	28.22	4.21	37.24	44.98	74.00	-29.02	Peak
3	7027.82	38.10	35.57	7.21	34.01	46.87	74.00	-27.13	Peak
4	11545.04	34.76	40.76	9.48	36.37	48.63	74.00	-25.37	Peak

Test channel		CH <sub>H</sub>			Polarity		Vertical		
Mark	Frequency MHz	Reading dBuV/m	Antenna dB	Cable dB	Preamp dB	Level dBuV/m	Limit dBuV/m	Over limit	Remark
1	1179.94	52.53	25.52	2.75	36.67	44.13	74.00	-29.87	Peak
2	2950.14	49.27	28.70	4.50	37.41	45.06	74.00	-28.94	Peak
3	4821.76	39.10	31.40	5.74	35.24	41.00	74.00	-33.00	Peak
4	11515.68	34.60	40.85	9.47	36.37	48.55	74.00	-25.45	Peak

## 5.19. AC Conducted Emission

### LIMIT

#### FCC CFR Title 47 Part 15 Subpart C Section 15.207

Frequency range (MHz)	Limit (dBuV)	
	Quasi-peak	Average
0.15-0.5	66 to 56*	56 to 46*
0.5-5	56	46
5-30	60	50

\* Decreases with the logarithm of the frequency.

### TEST CONFIGURATION

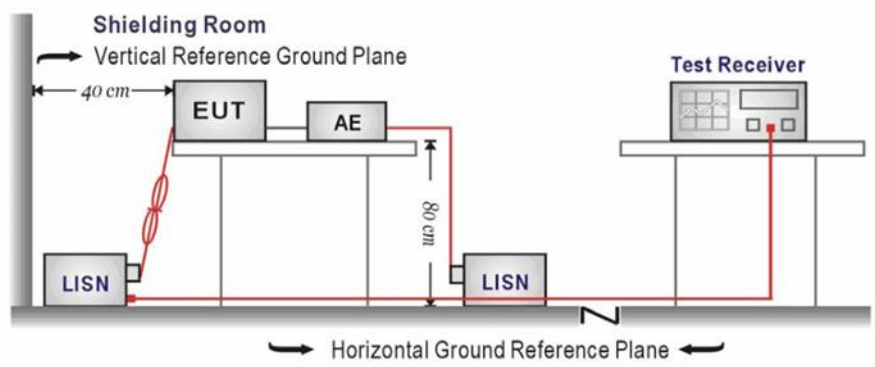

### TEST PROCEDURE

1. The EUT was setup according to ANSI C63.10 requirements.
2. The EUT was placed on a platform of nominal size, 1 m by 1.5 m, raised 80 cm above the conducting ground plane. The vertical conducting plane was located 40 cm to the rear of the EUT. All other surfaces of EUT were at least 80 cm from any other grounded conducting surface.
3. The EUT and simulators are connected to the main power through a line impedances stabilization network (LISN). The LISN provides a 50 ohm /50uH coupling impedance for the measuring equipment.
4. The peripheral devices are also connected to the main power through a LISN. (Please refer to the block diagram of the test setup and photographs)
5. Each current-carrying conductor of the EUT power cord, except the ground (safety) conductor, was individually connected through a LISN to the input power source.
6. The excess length of the power cord between the EUT and the LISN receptacle were folded back and forth at the center of the lead to form a bundle not exceeding 40 cm in length.
7. Conducted emissions were investigated over the frequency range from 0.15MHz to 30MHz using a receiver bandwidth of 9 kHz.
8. During the above scans, the emissions were maximized by cable manipulation.

### TEST MODE

Please refer to the clause 4.2

### TEST RESULT

Passed       Not Applicable



Test Line:

L

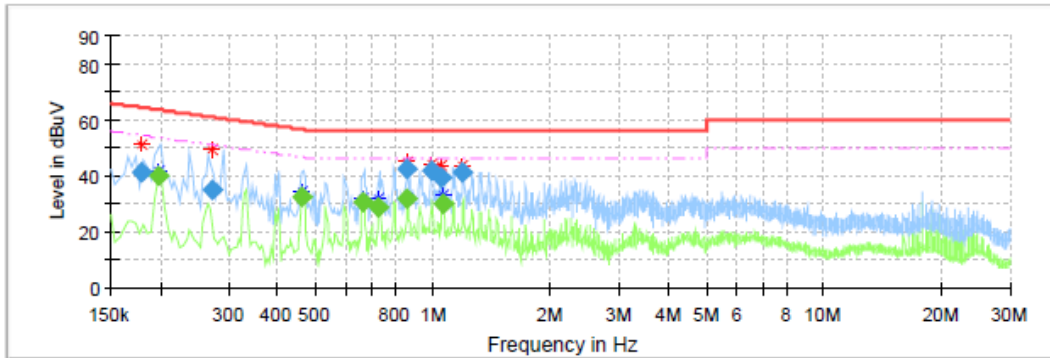

**Final Result**

Frequency (MHz)	QuasiPeak (dBuV)	CAverage (dBuV)	Limit (dBuV)	Margin (dB)	Line	Corr. (dB)	Filter
0.179500	41.46	---	64.51	23.05	L1	10.0	
0.199500	---	39.83	53.63	13.80	L1	10.0	
0.271500	35.17	---	61.07	25.90	L1	10.0	
0.463500	---	32.44	46.63	14.19	L1	10.0	
0.659500	---	30.79	46.00	15.21	L1	10.0	
0.723500	---	28.45	46.00	17.55	L1	10.0	
0.859500	---	32.16	46.00	13.84	L1	10.0	
0.859500	42.31	---	56.00	13.69	L1	10.0	
0.991500	42.08	---	56.00	13.92	L1	10.0	
1.055500	39.54	---	56.00	16.46	L1	10.0	
1.059500	---	29.89	46.00	16.11	L1	10.0	
1.191500	41.24	---	56.00	14.76	L1	10.0	

Test Line:

N

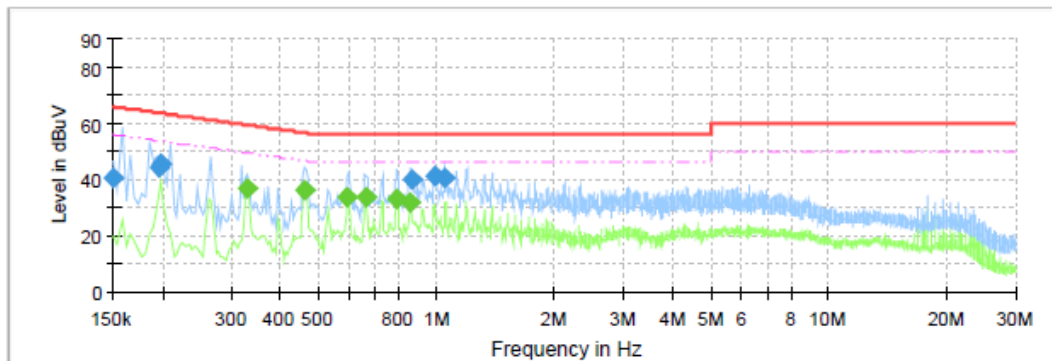

**Final Result**

Frequency (MHz)	QuasiPeak (dBuV)	CAverage (dBuV)	Limit (dBuV)	Margin (dB)	Line	Corr. (dB)
0.150000	40.36	---	66.00	25.64	N	10.0
0.195500	44.61	---	63.80	19.19	N	10.0
0.199500	45.39	---	63.63	18.24	N	10.0
0.331500	---	36.62	49.41	12.79	N	10.0
0.463500	---	36.16	46.63	10.47	N	10.0
0.591500	---	33.48	46.00	12.52	N	10.0
0.659500	---	33.45	46.00	12.55	N	10.0
0.791500	---	33.11	46.00	12.89	N	10.0
0.859500	---	31.90	46.00	14.10	N	10.0
0.863500	40.21	---	56.00	15.79	N	10.0
0.987500	41.39	---	56.00	14.61	N	10.0
1.055500	40.34	---	56.00	15.66	N	10.0

## **6. TEST SETUP PHOTOS**

Please refer to Appendix\_ Test Setup Photos.

## **7. EXTERNAL AND INTERNAL PHOTOS**

Please refer to Appendix\_ Internal photos and Appendix\_ External photos.

-----End of Report-----