



中认信通
CHINA CERTIFICATION ICT CO.,LTD (DONGGUAN)



SAR TEST REPORT

Applicant: YEALINK(XIAMEN) NETWORK TECHNOLOGY CO.,LTD.

Address: No.666 Hu'an Rd. Huli District Xiamen City, Fujian, P.R. China

FCC ID: T2C-BT51CV1

Product Name: Bluetooth USB Dongle

Model Number: BT51C

Multiple Models: N/A

Standard(s): 47 CFR Part 2(2.1093)

The above device has been tested and found compliant with the requirement of the relative standards by China Certification ICT Co., Ltd (Dongguan)

Report Number: CR231166695-SAA

Date Of Issue: 2023-12-10

Reviewed By: Karl Gong

Title: SAR Engineer

Test Laboratory: China Certification ICT Co., Ltd (Dongguan)

No. 113, Pingkang Road, Dalang Town, Dongguan,
Guangdong, China
Tel: +86-769-82016888

SAR TEST RESULTS SUMMARY

| Operation Frequency Bands | Highest Reported 1g SAR (W/kg) | Limits (W/kg) |
|---------------------------|--------------------------------|---------------|
| | Body SAR (Gap 5mm) | |
| Bluetooth | 0.38 | 1.6 |
| EUT Received Date: | 2023/11/11 | |
| Tested Date: | 2023/11/20 | |
| Tested Result: | Pass | |

Test Facility

The Test site used by China Certification ICT Co., Ltd (Dongguan) to collect test data is located on the No. 113, Pingkang Road, Dalang Town, Dongguan, Guangdong, China.

The lab has been recognized as the FCC accredited lab under the KDB 974614 D01 and is listed in the FCC Public Access Link (PAL) database, FCC Registration No. : 442868, the FCC Designation No. : CN1314.

The lab has been recognized by Innovation, Science and Economic Development Canada to test to Canadian radio equipment requirements, the CAB identifier: CN0123.

Declarations

China Certification ICT Co., Ltd (Dongguan) is not responsible for the authenticity of any test data provided by the applicant. Data included from the applicant that may affect test results are marked with a triangle symbol “▲”. Customer model name, addresses, names, trademarks etc. are not considered data.

Unless otherwise stated the results shown in this test report refer only to the sample(s) tested.

This report cannot be reproduced except in full, without prior written approval of the Company.

This report is valid only with a valid digital signature. The digital signature may be available only under the Adobe software above version 7.0.

This report may contain data that are not covered by the accreditation scope and shall be marked with an asterisk “★”.

CONTENTS

| | |
|---|-----------|
| DOCUMENT REVISION HISTORY | 5 |
| 1. GENERAL INFORMATION | 6 |
| 1.1 PRODUCT DESCRIPTION FOR EQUIPMENT UNDER TEST (EUT) | 6 |
| 1.2 TEST SPECIFICATION, METHODS AND PROCEDURES | 7 |
| 1.3 SAR LIMITS..... | 8 |
| 1.4 FACILITIES..... | 9 |
| 2. SAR MEASUREMENT SYSTEM | 10 |
| 3. EQUIPMENT LIST AND CALIBRATION | 17 |
| 3.1 EQUIPMENTS LIST & CALIBRATION INFORMATION | 17 |
| 4. SAR MEASUREMENT SYSTEM VERIFICATION | 18 |
| 4.1 LIQUID VERIFICATION | 18 |
| 4.2 SYSTEM ACCURACY VERIFICATION | 19 |
| 4.3 SAR SYSTEM VALIDATION DATA..... | 20 |
| 5. EUT TEST STRATEGY AND METHODOLOGY | 21 |
| 5.1 DONGLE TESTING PROCEDURES..... | 21 |
| 5.2 TEST DISTANCE FOR SAR EVALUATION..... | 21 |
| 5.3 SAR EVALUATION PROCEDURE | 22 |
| 6. CONDUCTED OUTPUT POWER MEASUREMENT | 23 |
| 6.1 TEST PROCEDURE..... | 23 |
| 6.2 MAXIMUM TARGET OUTPUT POWER..... | 23 |
| 6.3 TEST RESULTS: | 23 |
| 6.4 ANTENNAS LOCATION:..... | 25 |
| 7. SAR MEASUREMENT RESULTS | 26 |
| 8.1 SAR TEST DATA | 26 |
| 8. SAR Plots | 27 |
| APPENDIX A MEASUREMENT UNCERTAINTY | 34 |
| APPENDIX B EUT TEST POSITION PHOTOS | 36 |
| APPENDIX C PROBE CALIBRATION CERTIFICATES..... | 37 |
| APPENDIX D DIPOLE CALIBRATION CERTIFICATES..... | 46 |

DOCUMENT REVISION HISTORY

| Revision Number | Report Number | Description of Revision | Date of Revision |
|-----------------|-----------------|-------------------------|------------------|
| 1.0 | CR231166695-SAA | Original Report | 2023-12-10 |

1. GENERAL INFORMATION

1.1 Product Description for Equipment under Test (EUT)

| | |
|-------------------------------|----------------------------------|
| Device Type: | Portable |
| Exposure Category: | Population / Uncontrolled |
| Antenna Type(s): | Internal Antenna |
| Body-Worn Accessories: | None |
| Proximity Sensor: | None |
| Operation modes: | Bluetooth |
| Frequency Band: | Bluetooth: 2402-2480MHz |
| Modulation Technique: | GFSK, $\pi/4$ -DQPSK, 8DPSK |
| Conducted RF Power: | Bluetooth: 12.14 dBm |
| Dimensions (L*W*H): | 14 mm (L) * 14 mm (W) * 7 mm (H) |
| Rated Input Voltage: | DC 5V from USB port |
| Serial Number: | 2DDC-3 |
| Normal Operation: | Close to Body |

1.2 Test Specification, Methods and Procedures

The tests documented in this report were performed in accordance with FCC 47 CFR § 2.1093, IEEE 1528-2013, the following FCC Published RF exposure KDB procedures:

KDB 447498 D01 General RF Exposure Guidance v06
KDB 447498 D02 SAR Procedures for Dongle Xmtr v02r01
KDB 865664 D01 SAR Measurement 100 MHz to 6 GHz v01r04
KDB 865664 D02 RF Exposure Reporting v01r02

TCB Workshop April 2019: RF Exposure Procedures

1.3 SAR Limits**FCC Limit**

| EXPOSURE LIMITS | SAR (W/kg) | |
|--|--|--|
| | (General Population / Uncontrolled Exposure Environment) | (Occupational / Controlled Exposure Environment) |
| Spatial Average (averaged over the whole body) | 0.08 | 0.4 |
| Spatial Peak (averaged over any 1 g of tissue) | 1.60 | 8.0 |
| Spatial Peak (hands/wrists/feet/ankles averaged over 10 g) | 4.0 | 20.0 |

Population/Uncontrolled Environments are defined as locations where there is the exposure of individual who have no knowledge or control of their exposure.

Occupational/Controlled Environments are defined as locations where there is exposure that may be incurred by people who are aware of the potential for exposure (i.e. as a result of employment or occupation).

General Population/Uncontrolled environments Spatial Peak limit 1.6W/kg for 1g SAR applied to the EUT.

1.4 FACILITIES

The Test site used by China Certification ICT Co., Ltd (Dongguan) to collect test data is located on the No. 113, Pingkang Road, Dalang Town, Dongguan, Guangdong, China.

The test sites and measurement facilities used to collect data are located at:

| | |
|---|------------------------------------|
| <input checked="" type="checkbox"/> SAR Lab 1 | <input type="checkbox"/> SAR Lab 2 |
|---|------------------------------------|

2. SAR MEASUREMENT SYSTEM

These measurements were performed with the automated near-field scanning system DASY5 from Schmid & Partner Engineering AG (SPEAG) which is the Fifth generation of the system shown in the figure hereinafter:



DASY5 System Description

The DASY5 system for performing compliance tests consists of the following items:

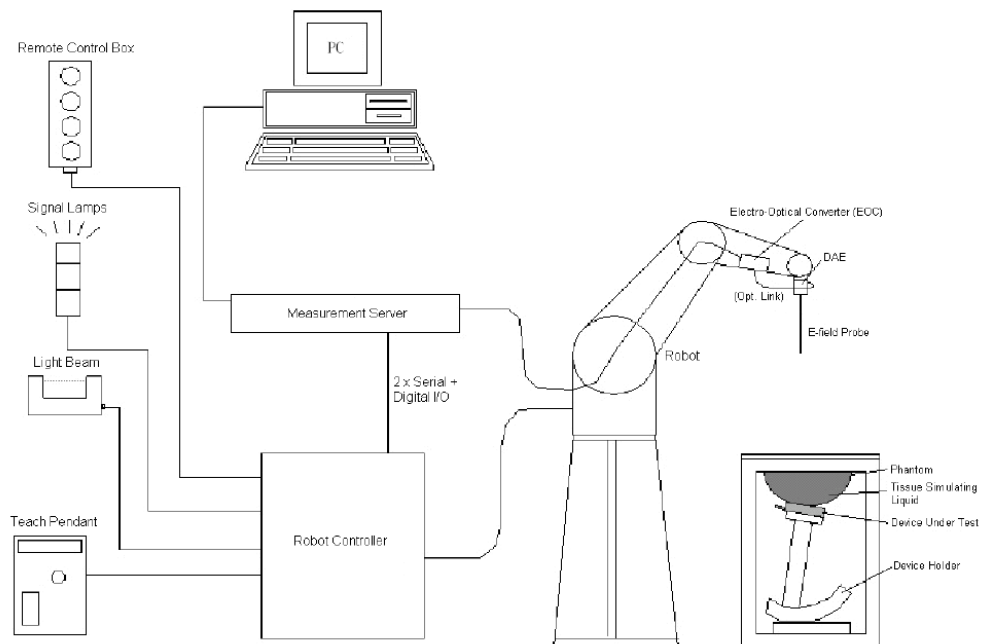

- A standard high precision 6-axis robot with controller, teach pendant and software. An arm extension for accommodating the data acquisition electronics (DAE).
- An isotropic field probe optimized and calibrated for the targeted measurement.
- A data acquisition electronics (DAE) which performs the signal application, signal multiplexing, AD-conversion, offset measurements, mechanical surface detection, collision detection, etc. The unit is battery powered with standard or rechargeable batteries. The signal is optically transmitted to the EOC.
- The Electro-optical converter (EOC) performs the conversion from optical to electrical signals for the digital communication to the DAE. To use optical surface detection, a special version of the EOC is required. The EOC signal is transmitted to the measurement server.
- The function of the measurement server is to perform the time critical tasks such as signal filtering, control of the robot operation and fast movement interrupts.
- The Light Beam used is for probe alignment. This improves the (absolute) accuracy of the probe positioning.
- A computer running Win7 professional operating system and the DASY52 software.
- Remote control and teach pendant as well as additional circuitry for robot safety such as warning lamps, etc.
- The phantom, the device holder and other accessories according to the targeted measurement.

DASY5 Measurement Server

The DASY5 measurement server is based on a PC/104 CPU board with a 400MHz Intel ULV Celeron, 128MB chip-disk and 128MB RAM. The necessary circuits for communication with the DAE4 (or DAE3) electronics box, as well as the 16 bit AD-converter system for optical detection and digital I/O interface are contained on the DASY5 I/O board, which is directly connected to the PC/104 bus of the CPU board.



The measurement server performs all real-time data evaluation of field measurements and surface detection, controls robot movements and handles safety operation. The PC operating system cannot interfere with these time critical processes. All connections are supervised by a watchdog, and disconnection of any of the cables to the measurement server will automatically disarm the robot and disable all program-controlled robot movements. Furthermore, the measurement server is equipped with an expansion port which is reserved for future applications. Please note that this expansion port does not have a standardized point out, and therefore only devices provided by SPEAG can be connected. Devices from any other supplier could seriously damage the measurement server.

Data Acquisition Electronics

The data acquisition electronics (DAE4) consist of a highly sensitive electrometer-grade preamplifier with auto-zeroing, a channel and gain-switching multiplexer, a fast 16 bit AD-converter and a command decoder with a control logic unit. Transmission to the measurement server is accomplished through an optical downlink for data and status information, as well as an optical uplink for commands and the clock.

The mechanical probe mounting device includes two different sensor systems for frontal and sideways probe contacts. They are used for mechanical surface detection and probe collision detection.

The input impedance of both the DAE4 as well as of the DAE3 box is 200M Ω ; the inputs are symmetrical and floating. Common mode rejection is above 80 dB.

ES3DV3 E-Field Probes

| | |
|----------------------|--|
| Frequency | 10 MHz - 4 GHz Linearity: ± 0.2 dB (30 MHz to 4 GHz) |
| Directivity | ± 0.2 dB in TSL (rotation around probe axis) ± 0.3 dB in TSL (rotation normal to probe axis) |
| Dynamic Range | 5 μ W/g to > 100 mW/g Linearity: ± 0.2 dB (noise: typically < 1 μ W/g) |
| Dimensions | Overall length: 337 mm (Tip: 20 mm) Tip diameter: 3.9 mm (Body: 12 mm) Typical distance from probe tip to dipole centers: 2.0 mm |
| Application | General dosimetry up to 4 GHz Dosimetry in strong gradient fields Compliance tests of mobile phones |
| Compatibility | DASY3, DASY4, DASY52, DASY6, DASY8, EASY6, EASY4/MRI |

Calibration Frequency Points for ES3DV3 E-Field Probes SN: 3157 Calibrated: 2023/4/10

| Calibration Frequency Point(MHz) | Frequency Range(MHz) | | Conversion Factor | | |
|----------------------------------|----------------------|------|-------------------|------|------|
| | From | To | X | Y | Z |
| 750 Head | 650 | 850 | 6.48 | 6.48 | 6.48 |
| 900 Head | 850 | 1000 | 6.25 | 6.25 | 6.25 |
| 1750 Head | 1650 | 1850 | 5.38 | 5.38 | 5.38 |
| 1900 Head | 1850 | 2000 | 5.18 | 5.18 | 5.18 |
| 2300 Head | 2200 | 2400 | 4.96 | 4.96 | 4.96 |
| 2450 Head | 2400 | 2550 | 4.74 | 4.74 | 4.74 |
| 2600 Head | 2550 | 2700 | 4.52 | 4.52 | 4.52 |

SAM Twin Phantom

The SAM twin phantom is a fiberglass shell phantom with 2mm shell thickness (except the ear region, where shell thickness increases to 6 mm). The phantom has three measurement areas:

- _ Left Head
- _ Right Head
- _ Flat phantom

The phantom table for the DASY systems based on the robots have the size of 100 x 50 x 85 cm (L x W x H). For easy dislocation these tables have fork lift cut outs at the bottom.

The bottom plate contains three pairs of bolts for locking the device holder. The device holder positions are adjusted to the standard measurement positions in the three sections. Only one device holder is necessary if two phantoms are used (e.g., for different liquids)



A white cover is provided to cover the phantom during off-periods to prevent water evaporation and changes in the liquid parameters. Free space scans of devices on top of this phantom cover are possible. Three reference marks are provided on the phantom counter. These reference marks are used to teach the absolute phantom position relative to the robot.

Robots

The DASY5 system uses the high precision industrial robot. The robot offers the same features important for our application:

- High precision (repeatability 0.02mm)
- High reliability (industrial design)
- Low maintenance costs (virtually maintenance free due to direct drive gears; no belt drives)
- Jerk-free straight movements (brushless synchrony motors; no stepper motors)
- Low ELF interference (motor control fields shielded via the closed metallic construction shields)

The above mentioned robots are controlled by the Staubli CS8c robot controllers. All information regarding the use and maintenance of the robot arm and the robot controller is contained on the CDs delivered along with the robot. Paper manuals are available upon request direct from Staubli.

SAR Scan Procedures

Step 1: Power Reference Measurement

The Power Reference Measurement and Power Drift Measurements are for monitoring the power drift of the device under test in the batch process. The minimum distance of probe sensors to surface determines the closest measurement point to phantom surface. The minimum distance of probe sensors to surface is 1.4 mm. This distance cannot be smaller than the distance of sensor calibration points to probe tip as defined in the probe properties.

Step 2: Area Scans

Area scans are defined prior to the measurement process being executed with a user defined variable spacing between each measurement point (integral) allowing low uncertainty measurements to be conducted. Scans defined for FCC applications utilize a 15mm 2 step integral, with 1.5mm interpolation used to locate the peak SAR area used for zoom scan assessments.

Where the system identifies multiple SAR peaks (which are within 25% of peak value) the system will provide the user with the option of assessing each peak location individually for zoom scan averaging.

Area Scan Parameters extracted from KDB 865664 D01 SAR Measurement 100 MHz to 6 GHz

| | ≤ 3 GHz | > 3 GHz |
|--|---|---|
| Maximum distance from closest measurement point (geometric center of probe sensors) to phantom surface | 5 mm ± 1 mm | $\frac{1}{2} \cdot \delta \cdot \ln(2)$ mm ± 0.5 mm |
| Maximum probe angle from probe axis to phantom surface normal at the measurement location | 30° ± 1° | 20° ± 1° |
| Maximum area scan spatial resolution: Δx_{Area} , Δy_{Area} | ≤ 2 GHz: ≤ 15 mm 2 – 3 GHz: ≤ 12 mm | 3 – 4 GHz: ≤ 12 mm 4 – 6 GHz: ≤ 10 mm |
| | When the x or y dimension of the test device, in the measurement plane orientation, is smaller than the above, the measurement resolution must be ≤ the corresponding x or y dimension of the test device with at least one measurement point on the test device. | |

Step 3: Zoom Scan (Cube Scan Averaging)

The averaging zoom scan volume utilized in the DASY5 software is in the shape of a cube and the side dimension of a 1 g or 10 g mass is dependent on the density of the liquid representing the simulated tissue. A density of 1000 kg/m³ is used to represent the head and body tissue density and not the phantom liquid density, in order to be consistent with the definition of the liquid dielectric properties, i.e. the side length of the 1 g cube is 5mm, with the side length of the 10g cube is 21.5mm.

Zoom Scan Parameters extracted from KDB 865664 D01 SAR Measurement 100 MHz to 6 GHz

| | | | ≤ 3 GHz | > 3 GHz |
|---|------------------------------------|--|--|---|
| Maximum zoom scan spatial resolution: Δx_{Zoom} , Δy_{Zoom} | | | ≤ 2 GHz: ≤ 8 mm 2 – 3 GHz: ≤ 5 mm* | 3 – 4 GHz: ≤ 5 mm* 4 – 6 GHz: ≤ 4 mm* |
| Maximum zoom scan spatial resolution, normal to phantom surface | uniform grid: $\Delta z_{Zoom}(n)$ | | ≤ 5 mm | 3 – 4 GHz: ≤ 4 mm 4 – 5 GHz: ≤ 3 mm 5 – 6 GHz: ≤ 2 mm |
| | graded grid | $\Delta z_{Zoom}(1)$: between 1 st two points closest to phantom surface | ≤ 4 mm | 3 – 4 GHz: ≤ 3 mm 4 – 5 GHz: ≤ 2.5 mm 5 – 6 GHz: ≤ 2 mm |
| | | $\Delta z_{Zoom}(n>1)$: between subsequent points | ≤ 1.5 · $\Delta z_{Zoom}(n-1)$ mm | |
| Minimum zoom scan volume | x, y, z | ≥ 30 mm | 3 – 4 GHz: ≥ 28 mm 4 – 5 GHz: ≥ 25 mm 5 – 6 GHz: ≥ 22 mm | |
| Note: δ is the penetration depth of a plane-wave at normal incidence to the tissue medium; see IEEE Std 1528-2013 for details. | | | | |
| * When zoom scan is required and the <i>reported</i> SAR from the <i>area scan based 1-g SAR estimation</i> procedures of KDB Publication 447498 is ≤ 1.4 W/kg, ≤ 8 mm, ≤ 7 mm and ≤ 5 mm zoom scan resolution may be applied, respectively, for 2 GHz to 3 GHz, 3 GHz to 4 GHz and 4 GHz to 6 GHz. | | | | |

Step 4: Power Drift Measurement

The Power Drift Measurement measures the field at the same location as the most recent power reference measurement within the same procedure, and with the same settings. The Power Drift Measurement gives the field difference in dB from the reading conducted within the last Power Reference Measurement. This allows a user to monitor the power drift of the device under test within a batch process. The measurement procedure is the same as Step 1.

When the cube intersects with the surface of the phantom, it is oriented so that 3 vertices touch the surface of the shell or the center of a face is tangent to the surface. The face of the cube closest to the surface is modified in order to conform to the tangent surface.

The zoom scan integer steps can be user defined so as to reduce uncertainty, but normal practice for typical test applications (including FCC) utilize a physical step of 7 x 7 x 7 (5mmx5mmx5mm) providing a volume of 30 mm in the X & Y & Z axis.

Tissue Dielectric Parameters for Head and Body Phantoms

The head tissue dielectric parameters recommended by the IEC 62209-1:2016

Recommended Tissue Dielectric Parameters for Head liquid

Table A.3 – Dielectric properties of the head tissue-equivalent liquid

| Frequency MHz | Relative permittivity ϵ_r | Conductivity (σ) S/m |
|------------------|---------------------------------------|----------------------------------|
| 300 | 45,3 | 0,87 |
| 450 | 43,5 | 0,87 |
| <i>750</i> | <i>41,9</i> | <i>0,89</i> |
| 835 | 41,5 | 0,90 |
| 900 | 41,5 | 0,97 |
| 1 450 | 40,5 | 1,20 |
| <i>1 500</i> | <i>40,4</i> | <i>1,23</i> |
| <i>1 640</i> | <i>40,2</i> | <i>1,31</i> |
| <i>1 750</i> | <i>40,1</i> | <i>1,37</i> |
| 1 800 | 40,0 | 1,40 |
| 1 900 | 40,0 | 1,40 |
| 2 000 | 40,0 | 1,40 |
| <i>2 100</i> | <i>39,8</i> | <i>1,49</i> |
| <i>2 300</i> | <i>39,5</i> | <i>1,67</i> |
| 2 450 | 39,2 | 1,80 |
| <i>2 600</i> | <i>39,0</i> | <i>1,96</i> |
| 3 000 | 38,5 | 2,40 |
| <i>3 500</i> | <i>37,9</i> | <i>2,91</i> |
| <i>4 000</i> | <i>37,4</i> | <i>3,43</i> |
| <i>4 500</i> | <i>36,8</i> | <i>3,94</i> |
| <i>5 000</i> | <i>36,2</i> | <i>4,45</i> |
| <i>5 200</i> | <i>36,0</i> | <i>4,66</i> |
| <i>5 400</i> | <i>35,8</i> | <i>4,86</i> |
| <i>5 600</i> | <i>35,5</i> | <i>5,07</i> |
| <i>5 800</i> | <i>35,3</i> | <i>5,27</i> |
| 6 000 | 35,1 | 5,48 |

NOTE For convenience, permittivity and conductivity values at those frequencies which are not part of the original data provided by Drossos et al. [33] or the extension to 5 800 MHz are provided (i.e. the values shown *in italics*). These values were linearly interpolated between the values in this table that are immediately above and below these values, except the values at 6 000 MHz that were linearly extrapolated from the values at 3 000 MHz and 5 800 MHz.

3. EQUIPMENT LIST AND CALIBRATION

3.1 Equipments List & Calibration Information

| Equipment | Model | S/N | Calibration Date | Calibration Due Date |
|---|-----------------|------------------|------------------|----------------------|
| DASY5 Test Software | DASY52.10 | N/A | NCR | NCR |
| DASY5 Measurement Server | DASY5 4.5.12 | 1567 | NCR | NCR |
| Data Acquisition Electronics | DAE4 | 1493 | 2023/3/17 | 2024/3/16 |
| E-Field Probe | ES3DV3 | 3157 | 2023/4/10 | 2024/4/9 |
| Mounting Device | MD4HHTV5 | BJPCTC0152 | NCR | NCR |
| Twin SAM | Twin SAM V5.0 | 1412 | NCR | NCR |
| Dipole, 2450 MHz | D2450V2 | 1102 | 2023/3/27 | 2026/3/26 |
| Simulated Tissue Liquid Head (500-9500 MHz) | HBBL600-10000V6 | 220420-2 | Each Time | / |
| Network Analyzer | 8753B | 2828A00170 | 2023/10/17 | 2024/10/16 |
| Dielectric assessment kit | 1319 | SM DAK 040 CA | NCR | NCR |
| MXG Vector Signal Generator | N5182B | MY51350144 | 2023/3/31 | 2024/3/30 |
| Power Meter | EPM-441A/8484A | GB37481494 | 2023/3/31 | 2024/3/30 |
| USB Wideband Power Sensor | U2021XA | MY54080015 | 2023/3/31 | 2024/3/30 |
| Power Amplifier | ZVE-6W-83+ | 637202210 | NCR | NCR |
| Directional Coupler | 441493 | 520Z | NCR | NCR |
| Attenuator | 20dB, 100W | LN749 | NCR | NCR |
| Attenuator | 6dB, 150W | 2754 | NCR | NCR |
| Spectrum Analyzer | FSV40-N | 102259 | 2023/4/18 | 2024/4/17 |
| Coaxial Cable | SMA-178 | 211001 | Each time | N/A |
| Coaxial Attenuator | 2W-SMA-JK-18G | 21060301 | Each time | N/A |
| Thermometer | DTM3000 | 3892 | 2023/3/31 | 2024/3/30 |

4. SAR MEASUREMENT SYSTEM VERIFICATION

4.1 Liquid Verification

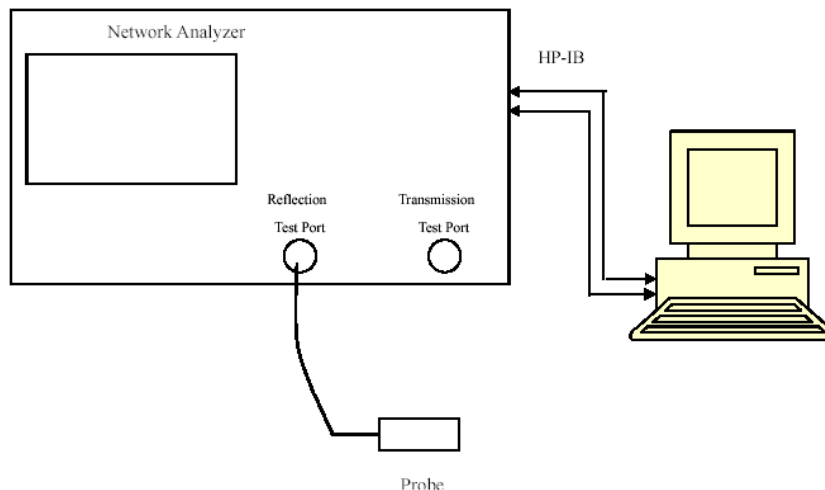

Liquid Verification Setup Block Diagram

Liquid Verification Results

| Frequency (MHz) | Liquid Type | Liquid Parameter | | Target Value | | Delta (%) | | Tolerance (%) |
|-----------------|------------------------------|------------------|----------------|--------------|----------------|--------------------|----------------|---------------|
| | | ϵ_r | σ (S/m) | ϵ_r | σ (S/m) | $\Delta\epsilon_r$ | $\Delta\sigma$ | |
| 2402 | Simulated Tissue Liquid Head | 39.201 | 1.811 | 39.30 | 1.76 | -0.25 | 2.90 | ± 5 |
| 2441 | Simulated Tissue Liquid Head | 38.491 | 1.830 | 39.22 | 1.79 | -1.86 | 2.23 | ± 5 |
| 2450 | Simulated Tissue Liquid Head | 38.328 | 1.834 | 39.20 | 1.80 | -2.22 | 1.89 | ± 5 |
| 2480 | Simulated Tissue Liquid Head | 39.723 | 1.895 | 39.16 | 1.83 | 1.44 | 3.55 | ± 5 |

*Liquid Verification above was performed on 2023/11/20.

4.2 System Accuracy Verification

Prior to the assessment, the system validation kit was used to test whether the system was operating within its specifications of $\pm 10\%$. The validation results are tabulated below. And also the corresponding SAR plot is attached as well in the SAR plots files.

The spacing distances in the **System Verification Setup Block Diagram** is given by the following:

- a) $s = 15 \text{ mm} \pm 0,2 \text{ mm}$ for $300 \text{ MHz} \leq f \leq 1 \text{ 000 MHz}$;
- b) $s = 10 \text{ mm} \pm 0,2 \text{ mm}$ for $1 \text{ 000 MHz} < f \leq 3 \text{ 000 MHz}$;
- c) $s = 10 \text{ mm} \pm 0,2 \text{ mm}$ for $3 \text{ 000 MHz} < f \leq 6 \text{ 000 MHz}$.

System Verification Setup Block Diagram

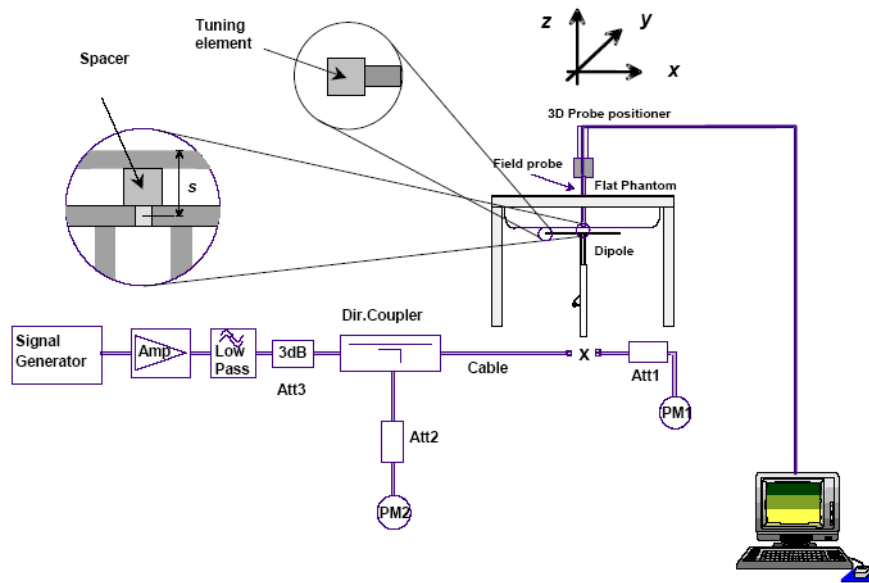

System Accuracy Check Results

| Date | Frequency Band | Liquid Type | Input Power (mW) | Measured SAR (W/kg) | Normalized to 1W (W/kg) | Target Value (W/kg) | Delta (%) | Tolerance (%) |
|------------|----------------|------------------------------|------------------|---------------------|-------------------------|---------------------|-----------|---------------|
| 2023/11/20 | 2450 MHz | Simulated Tissue Liquid Head | 100 | 1g 5.24 | 52.4 | 50.9 | 2.95 | ± 10 |

*The SAR values above are normalized to 1 Watt forward power.

4.3 SAR SYSTEM VALIDATION DATA

System Performance 2450MHz Head

DUT: D2450V2; Type: 2450 MHz; Serial: 1102

Communication System: CW; Frequency: 2450 MHz; Duty Cycle: 1:1
Medium parameters used: $f = 2450$ MHz; $\sigma = 1.834$ S/m; $\epsilon_r = 38.328$; $\rho = 1000$ kg/m³
Phantom section: Flat Section

DASY5 Configuration:

- Probe: ES3DV3 - SN3157; ConvF(4.74, 4.74, 4.74) @ 2450 MHz;
- Sensor-Surface: 3mm (Mechanical Surface Detection)
- Electronics: DAE4 Sn1493; Calibrated: 2023/3/17
- Phantom: Twin SAM; Type: Twin SAM V5.0; Serial: TP:1412
- Measurement SW: DASY52, Version 52.10 (2); SEMCAD X Version 14.6.12 (7470)

Area Scan (7x10x1): Measurement grid: dx=12mm, dy=12mm
Maximum value of SAR (measured) = 8.16 W/kg

Zoom Scan (7x7x7)/Cube 0: Measurement grid: dx=5mm, dy=5mm, dz=5mm
Reference Value = 45.79 V/m; Power Drift = 0.10 dB
Peak SAR (extrapolated) = 9.92 W/kg
SAR(1 g) = 5.24 W/kg; SAR(10 g) = 2.36 W/kg
Maximum value of SAR (measured) = 8.07 W/kg

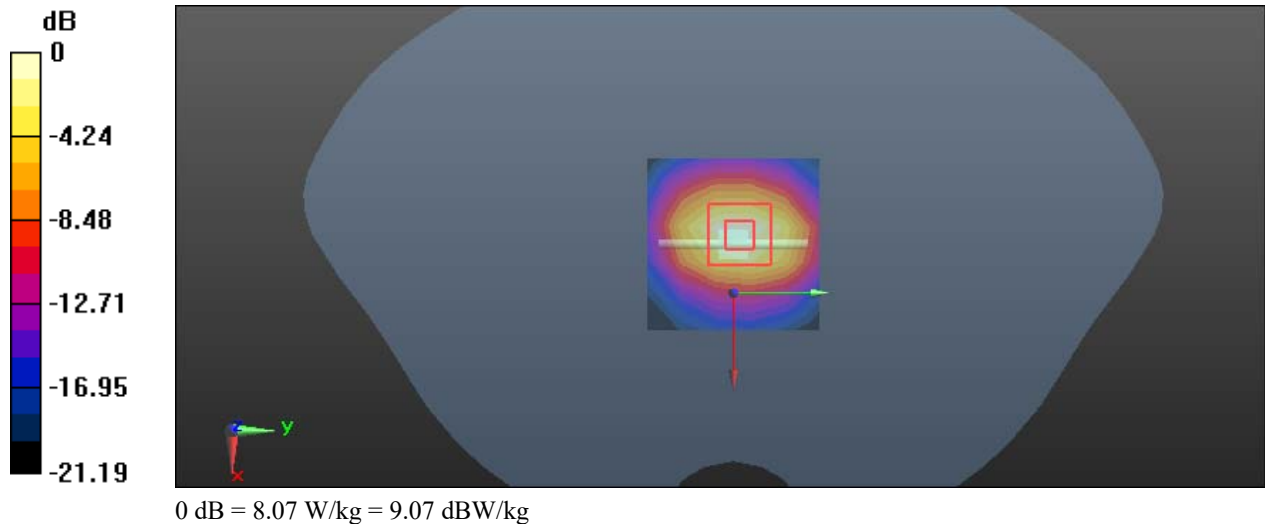

5. EUT TEST STRATEGY AND METHODOLOGY

5.1 DONGLE TESTING PROCEDURES

Test all USB orientations [see figure below: (A) Horizontal-Up, (B) Horizontal-Down, (C) Vertical-Front, and (D) Vertical-Back] with a device-to-phantom separation distance of 5 mm or less, according to KDB Publication 447498 D01 requirements. These test orientations are intended for the exposure conditions found in typical laptop/notebook/netbook or tablet computers with either horizontal or vertical USB connector configurations at various locations in the keyboard section of the computer. Current generation portable host computers should be used to establish the required SAR measurement separation distance. The same test separation distance must be used to test all frequency bands and modes in each USB orientation. The typical Horizontal-Up USB connection (A), found in the majority of host computers, must be tested using an appropriate host computer. A host computer with either Vertical-Front (C) or Vertical-Back (D) USB connection should be used to test one of the vertical USB orientations. If a suitable host computer is not available for testing the Horizontal-Down (B) or the remaining Vertical USB orientation, a high quality USB cable, 12 inches or less, may be used for testing these other orientations. It must be documented that the USB cable does not influence the radiating characteristics and output power of the transmitter.

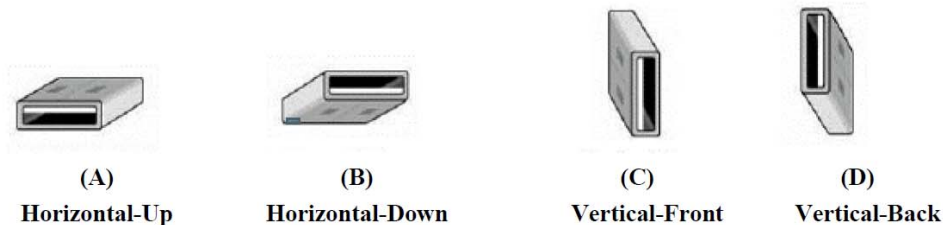

Note: These are USB connector orientations on laptop computers; USB dongles have the reverse configuration for plugging into the corresponding laptop computers.

Figure 1 – USB Connector Orientations Implemented on Laptop Computers

5.2 Test Distance for SAR Evaluation

In this case the EUT (Equipment Under Test) is set 5mm away from the phantom, the test distance is 5mm.

5.3 SAR Evaluation Procedure

The evaluation was performed with the following procedure:

Step 1: Measurement of the SAR value at a fixed location above the ear point or central position was used as a reference value for assessing the power drop. The SAR at this point is measured at the start of the test and then again at the end of the testing.

Step 2: The SAR distribution at the exposed side of the head was measured at a distance of 4 mm from the inner surface of the shell. The area covered the entire dimension of the head or radiating structures of the EUT, the horizontal grid spacing was 15 mm x 15 mm, and the SAR distribution was determined by integrated grid of 1.5mm x 1.5mm. Based on these data, the area of the maximum absorption was determined by spline interpolation. The first Area Scan covers the entire dimension of the EUT to ensure that the hotspot was correctly identified.

Step 3: Around this point, a volume of 30 mm x 30 mm x 30 mm was assessed by measuring 7x 7 x 7 points. On the basis of this data set, the spatial peak SAR value was evaluated under the following procedure:

1) The data at the surface were extrapolated, since the center of the dipoles is 1.2 mm away from the tip of the probe and the distance between the surface and the lowest measuring point is 1.3 mm. The extrapolation was based on a least square algorithm. A polynomial of the fourth order was calculated through the points in z-axes. This polynomial was then used to evaluate the points between the surface and the probe tip.

2) The maximum Measured value was searched with a straightforward algorithm. Around this maximum the SAR values averaged over the spatial volumes (1 g or 10 g) were computed by the 3D-Spline interpolation algorithm. The 3D-Spline is composed of three one dimensional splines with the "Not a knot"-condition (in x, y and z-directions). The volume was integrated with the trapezoidal-algorithm. One thousand points (10 x 10 x 10) were Measured to calculate the averages.

All neighboring volumes were evaluated until no neighboring volume with a higher average value was found.

Step 4: Re-measurement of the SAR value at the same location as in Step 1. If the value changed by more than 5%, the evaluation was repeated.

6. CONDUCTED OUTPUT POWER MEASUREMENT

6.1 Test Procedure

The RF output of the transmitter was connected to the input port of the Spectrum Analyzer through Connector.

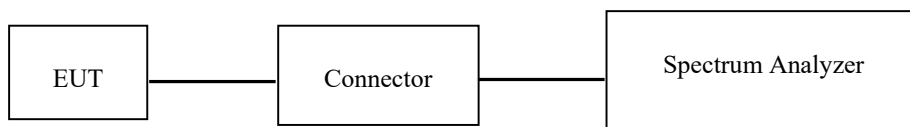

Bluetooth

6.2 Maximum Target Output Power

| Max Target Power(dBm) | | | |
|-----------------------|---------|--------|------|
| Mode/Band | Channel | | |
| | Low | Middle | High |
| Bluetooth | 12.3 | 12.3 | 12.3 |

6.3 Test Results:

Bluetooth:

| Mode | Channel frequency (MHz) | RF Output Power (dBm) |
|----------------------|-------------------------|-----------------------|
| BDR(GFSK) | 2402 | 12.14 |
| | 2441 | 12.13 |
| | 2480 | 11.99 |
| EDR($\pi/4$ -DQPSK) | 2402 | 12.09 |
| | 2441 | 12.11 |
| | 2480 | 11.98 |
| EDR(8DPSK) | 2402 | 12.06 |
| | 2441 | 12.07 |
| | 2480 | 11.95 |

Note:

1. RF Output Power was from Radio report.
2. Duty Cycle =1:1.268 (0.7885)

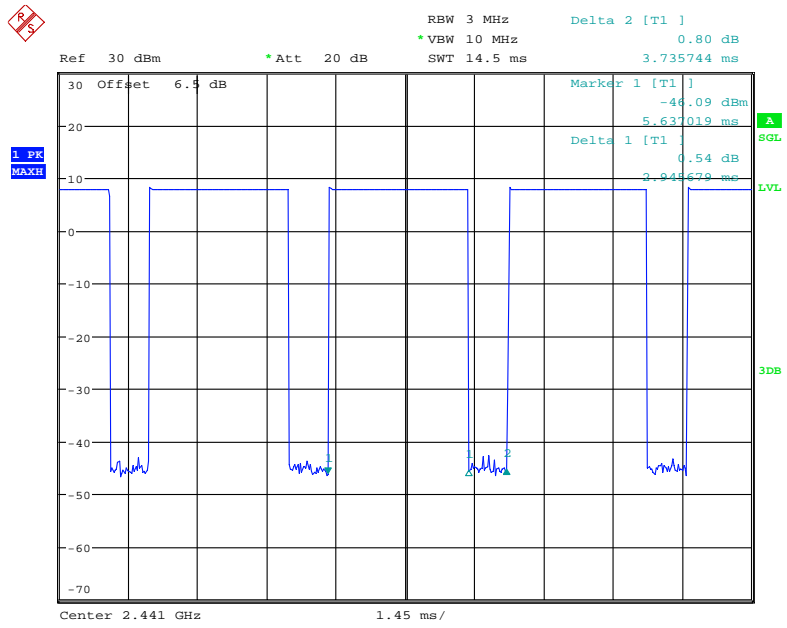

Date: 20.NOV.2023 18:05:46

Duty Cycle

6.4 Antennas Location:



Horizontal-Up View

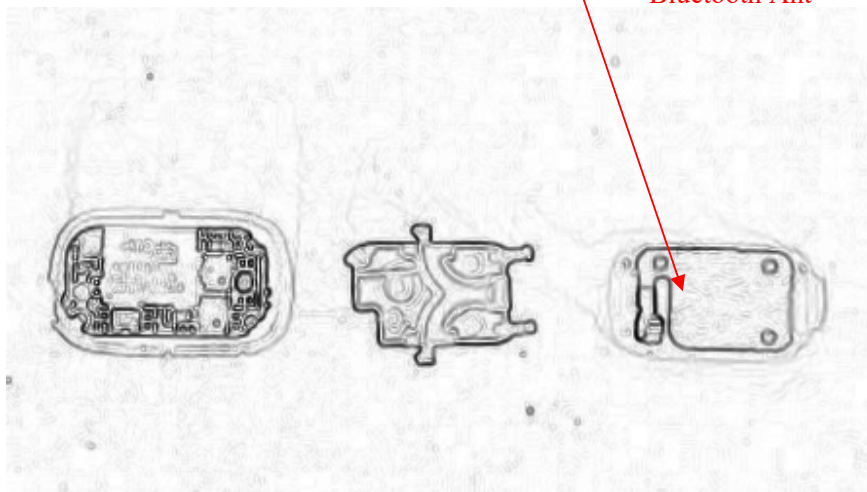

Bluetooth Ant

7. SAR MEASUREMENT RESULTS

This page summarizes the results of the performed dosimetric evaluation.

8.1 SAR Test Data

Environmental Conditions

| | |
|--------------------|-------------|
| Temperature: | 22.6~23.4°C |
| Relative Humidity: | 57 % |
| ATM Pressure: | 101.3 kPa |
| Test Date: | 2023/11/20 |

Testing was performed by Ken Zong.

Bluetooth:

| EUT Position | Frequency (MHz) | Test Mode | Max. Meas. Power (dBm) | Max. Rated Power (dBm) | 1g SAR (W/kg) | | | | |
|-----------------------|-----------------|-----------|------------------------|------------------------|---------------------|-------------------|-----------|------------|------|
| | | | | | Power Scaled Factor | Duty cycle Factor | Meas. SAR | Scaled SAR | Plot |
| Horizontal-Up (5mm) | 2402 | GFSK | 12.14 | 12.3 | 1.038 | 1.268 | 0.179 | 0.24 | 1# |
| | 2441 | GFSK | 12.13 | 12.3 | 1.040 | 1.268 | 0.196 | 0.26 | 2# |
| | 2480 | GFSK | 11.99 | 12.3 | 1.074 | 1.268 | 0.282 | 0.38 | 3# |
| Horizontal-Down (5mm) | 2402 | GFSK | / | / | / | / | / | / | / |
| | 2441 | GFSK | 12.13 | 12.3 | 1.040 | 1.268 | 0.187 | 0.25 | 4# |
| | 2480 | GFSK | / | / | / | / | / | / | / |
| Vertical-Front (5mm) | 2402 | GFSK | / | / | / | / | / | / | / |
| | 2441 | GFSK | 12.13 | 12.3 | 1.040 | 1.268 | 0.154 | 0.20 | 5# |
| | 2480 | GFSK | / | / | / | / | / | / | / |
| Vertical-Back (5mm) | 2402 | GFSK | / | / | / | / | / | / | / |
| | 2441 | GFSK | 12.13 | 12.3 | 1.040 | 1.268 | 0.153 | 0.20 | 6# |
| | 2480 | GFSK | / | / | / | / | / | / | / |
| Body Top (5mm) | 2402 | GFSK | / | / | / | / | / | / | / |
| | 2441 | GFSK | 12.13 | 12.3 | 1.040 | 1.268 | 0.026 | 0.03 | 7# |
| | 2480 | GFSK | / | / | / | / | / | / | / |

Note:

1. When the SAR value is less than half of the limit, testing for other channels are optional.
2. When SAR or MPE is not measured at the maximum power level allowed for production to the individual channels tested to determine compliance.
3. According 2016 Oct. TCB, for SAR testing of Bluetooth signal with non-100% duty cycle, the measured SAR is scaled-up by the duty cycle scaling factor which is equal to "1/(duty cycle)".
4. According to IEEE 1528-2013, If the percentage of permittivity and conductivity to the target value is within $\pm 5\%$, the measured SAR results shall not be corrected.
5. Since BDR(GFSK) mode is the largest power mode of BDR(GFSK)/ EDR($\pi/4$ -DQPSK)/ EDR(8DPSK), BDR(GFSK) mode is selected to test.

8. SAR Plots

Plot: 1#

DUT: Bluetooth USB Dongle; Type: BT51C; Serial: 2DDC-3

Communication System: UID 0, Bluetooth(GFSK) (0); Frequency: 2402 MHz; Duty Cycle: 1:1.268
 Medium parameters used: $f = 2402$ MHz; $\sigma = 1.811$ S/m; $\epsilon_r = 39.201$; $\rho = 1000$ kg/m³
 Phantom section: Flat Section

DASY5 Configuration:

- Probe: ES3DV3 - SN3157; ConvF(4.74, 4.74, 4.74) @ 2402 MHz;
- Sensor-Surface: 3mm (Mechanical Surface Detection)
- Electronics: DAE4 Sn1493; Calibrated: 2023/3/17
- Phantom: Twin SAM; Type: Twin SAM V5.0; Serial: TP:1412
- Measurement SW: DASY52, Version 52.10 (2); SEMCAD X Version 14.6.12 (7470)

Horizontal-UP/Bluetooth BDR(GFSK) Low/Area Scan (11x11x1): Measurement grid: dx=10mm, dy=10mm
 Maximum value of SAR (measured) = 0.264 W/kg

Horizontal-UP/Bluetooth BDR(GFSK) Low/Zoom Scan (7x7x7)/Cube 0: Measurement grid: dx=5mm, dy=5mm, dz=5mm
 Reference Value = 10.11 V/m; Power Drift = 0.01 dB
 Peak SAR (extrapolated) = 0.356 W/kg
SAR(1 g) = 0.179 W/kg; SAR(10 g) = 0.085 W/kg
 Maximum value of SAR (measured) = 0.289 W/kg

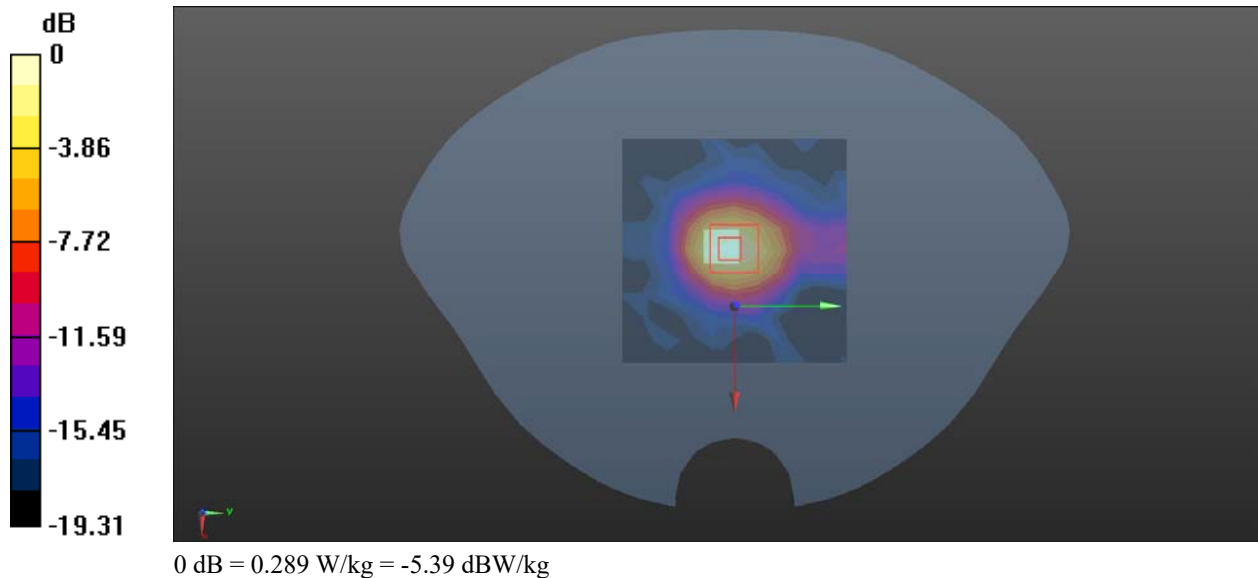

Plot: 2#**DUT: Bluetooth USB Dongle; Type: BT51C; Serial: 2DDC-3**

Communication System: UID 0, Bluetooth(GFSK) (0); Frequency: 2441 MHz; Duty Cycle: 1:1.268
Medium parameters used: $f = 2441$ MHz; $\sigma = 1.83$ S/m; $\epsilon_r = 38.491$; $\rho = 1000$ kg/m³
Phantom section: Flat Section

DASY5 Configuration:

- Probe: ES3DV3 - SN3157; ConvF(4.74, 4.74, 4.74) @ 2441 MHz;
- Sensor-Surface: 3mm (Mechanical Surface Detection)
- Electronics: DAE4 Sn1493; Calibrated: 2023/3/17
- Phantom: Twin SAM; Type: Twin SAM V5.0; Serial: TP:1412
- Measurement SW: DASY52, Version 52.10 (2); SEMCAD X Version 14.6.12 (7470)

Horizontal-UP/Bluetooth BDR(GFSK) Mid/Area Scan (11x11x1): Measurement grid: dx=10mm, dy=10mm
Maximum value of SAR (measured) = 0.238 W/kg

Horizontal-UP/Bluetooth BDR(GFSK) Mid/Zoom Scan (7x7x7)/Cube 0: Measurement grid: dx=5mm, dy=5mm, dz=5mm

Reference Value = 6.897 V/m; Power Drift = 0.03 dB

Peak SAR (extrapolated) = 0.386 W/kg

SAR(1 g) = 0.196 W/kg; SAR(10 g) = 0.095 W/kg

Maximum value of SAR (measured) = 0.311 W/kg

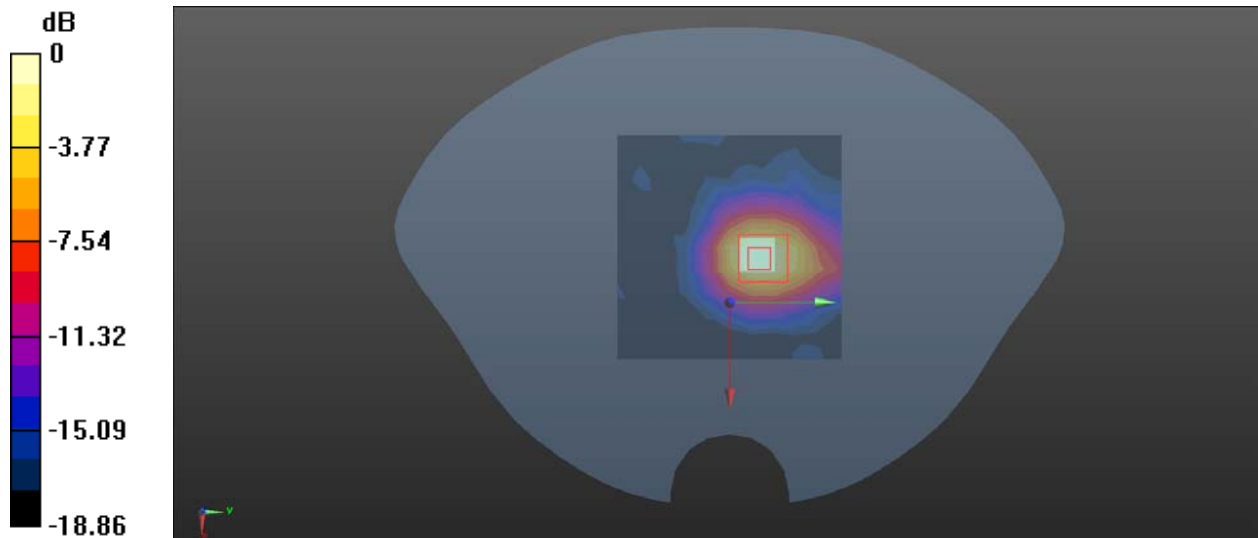

0 dB = 0.311 W/kg = -5.07 dBW/kg

Plot: 3#**DUT: Bluetooth USB Dongle; Type: BT51C; Serial: 2DDC-3**

Communication System: UID 0, Bluetooth(GFSK) (0); Frequency: 2480 MHz; Duty Cycle: 1:1.268
 Medium parameters used: $f = 2480$ MHz; $\sigma = 1.895$ S/m; $\epsilon_r = 39.723$; $\rho = 1000$ kg/m³
 Phantom section: Flat Section

DASY5 Configuration:

- Probe: ES3DV3 - SN3157; ConvF(4.74, 4.74, 4.74) @ 2480 MHz;
- Sensor-Surface: 3mm (Mechanical Surface Detection)
- Electronics: DAE4 Sn1493; Calibrated: 2023/3/17
- Phantom: Twin SAM; Type: Twin SAM V5.0; Serial: TP:1412
- Measurement SW: DASY52, Version 52.10 (2); SEMCAD X Version 14.6.12 (7470)

Horizontal-UP/Bluetooth BDR(GFSK) High/Area Scan (11x11x1): Measurement grid: dx=10mm, dy=10mm
 Maximum value of SAR (measured) = 0.318 W/kg

Horizontal-UP/Bluetooth BDR(GFSK) High/Zoom Scan (7x7x7)/Cube 0: Measurement grid: dx=5mm, dy=5mm, dz=5mm

Reference Value = 10.66 V/m; Power Drift = -0.08 dB

Peak SAR (extrapolated) = 0.685 W/kg

SAR(1 g) = 0.282 W/kg; SAR(10 g) = 0.126 W/kg

Maximum value of SAR (measured) = 0.491 W/kg

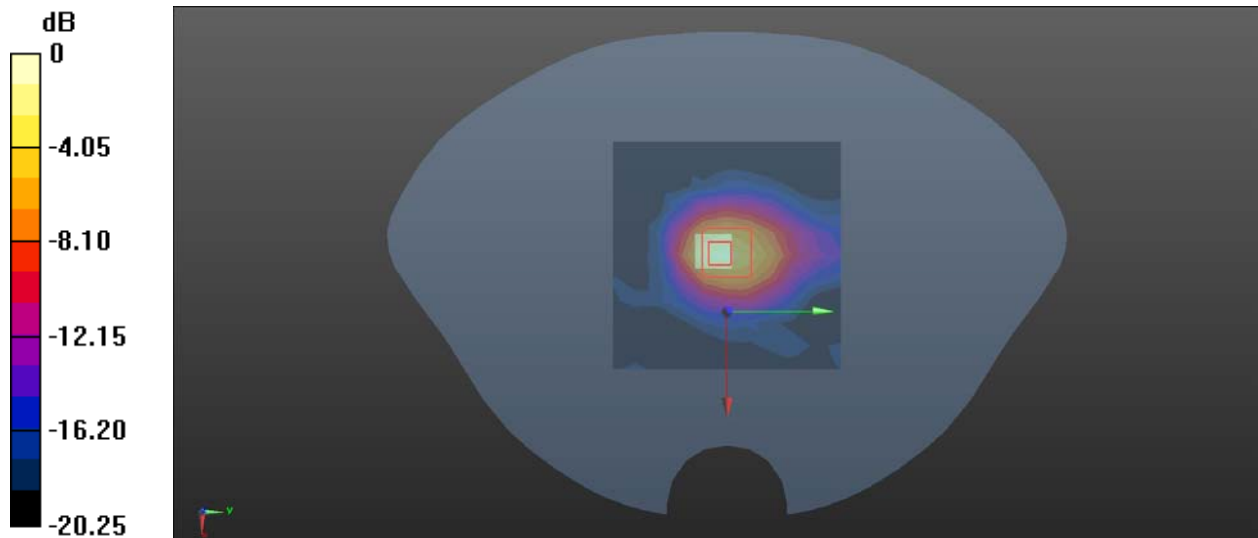

0 dB = 0.491 W/kg = -3.09 dBW/kg

Plot: 4#**DUT: Bluetooth USB Dongle; Type: BT51C; Serial: 2DDC-3**

Communication System: UID 0, Bluetooth(GFSK) (0); Frequency: 2441 MHz; Duty Cycle: 1:1.268
Medium parameters used: $f = 2441$ MHz; $\sigma = 1.83$ S/m; $\epsilon_r = 38.491$; $\rho = 1000$ kg/m³
Phantom section: Flat Section

DASY5 Configuration:

- Probe: ES3DV3 - SN3157; ConvF(4.74, 4.74, 4.74) @ 2441 MHz;
- Sensor-Surface: 3mm (Mechanical Surface Detection)
- Electronics: DAE4 Sn1493; Calibrated: 2023/3/17
- Phantom: Twin SAM; Type: Twin SAM V5.0; Serial: TP:1412
- Measurement SW: DASY52, Version 52.10 (2); SEMCAD X Version 14.6.12 (7470)

Horizontal-Down/Bluetooth BDR(GFSK) Mid/Area Scan (11x11x1): Measurement grid: dx=10mm, dy=10mm
Maximum value of SAR (measured) = 0.366 W/kg

Horizontal-Down/Bluetooth BDR(GFSK) Mid/Zoom Scan (7x7x7)/Cube 0: Measurement grid: dx=5mm, dy=5mm, dz=5mm

Reference Value = 9.482 V/m; Power Drift = 0.12 dB

Peak SAR (extrapolated) = 0.365 W/kg

SAR(1 g) = 0.187 W/kg; SAR(10 g) = 0.088 W/kg

Maximum value of SAR (measured) = 0.288 W/kg

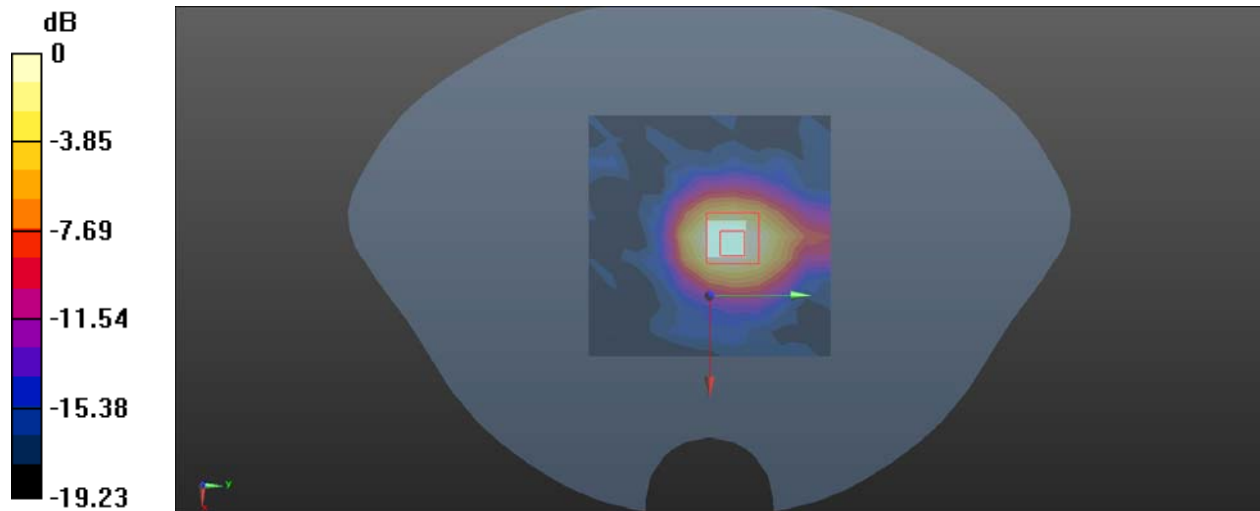

0 dB = 0.288 W/kg = -5.41 dBW/kg

Plot: 5#**DUT: Bluetooth USB Dongle; Type: BT51C; Serial: 2DDC-3**

Communication System: UID 0, Bluetooth(GFSK) (0); Frequency: 2441 MHz; Duty Cycle: 1:1.268

Medium parameters used: $f = 2441$ MHz; $\sigma = 1.83$ S/m; $\epsilon_r = 38.491$; $\rho = 1000$ kg/m³

Phantom section: Flat Section

DASY5 Configuration:

- Probe: ES3DV3 - SN3157; ConvF(4.74, 4.74, 4.74) @ 2441 MHz;
- Sensor-Surface: 3mm (Mechanical Surface Detection)
- Electronics: DAE4 Sn1493; Calibrated: 2023/3/17
- Phantom: Twin SAM; Type: Twin SAM V5.0; Serial: TP:1412
- Measurement SW: DASY52, Version 52.10 (2); SEMCAD X Version 14.6.12 (7470)

Vertical-Front/Bluetooth BDR(GFSK) Mid/Area Scan (11x11x1): Measurement grid: dx=10mm, dy=10mm

Maximum value of SAR (measured) = 0.248 W/kg

Vertical-Front/Bluetooth BDR(GFSK) Mid/Zoom Scan (7x7x7)/Cube 0: Measurement grid: dx=5mm, dy=5mm, dz=5mm

Reference Value = 9.612 V/m; Power Drift = 0.11 dB

Peak SAR (extrapolated) = 0.311 W/kg

SAR(1 g) = 0.154 W/kg; SAR(10 g) = 0.075 W/kg

Maximum value of SAR (measured) = 0.252 W/kg

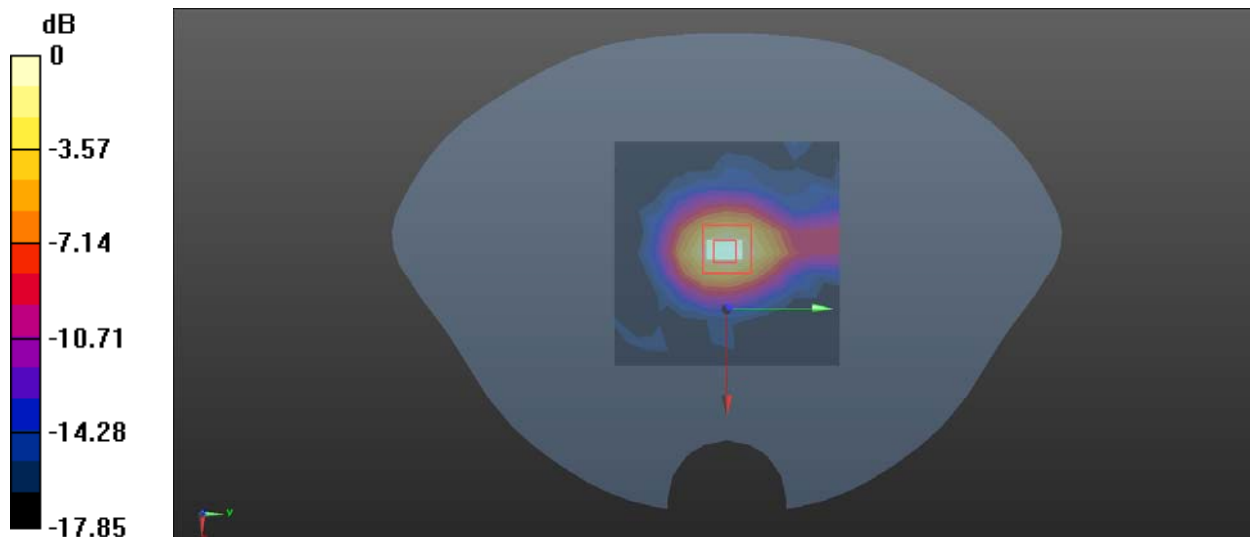

0 dB = 0.252 W/kg = -5.99 dBW/kg

Plot: 6#**DUT: Bluetooth USB Dongle; Type: BT51C; Serial: 2DDC-3**

Communication System: UID 0, Bluetooth(GFSK) (0); Frequency: 2441 MHz; Duty Cycle: 1:1.268
Medium parameters used: $f = 2441$ MHz; $\sigma = 1.83$ S/m; $\epsilon_r = 38.491$; $\rho = 1000$ kg/m³
Phantom section: Flat Section

DASY5 Configuration:

- Probe: ES3DV3 - SN3157; ConvF(4.74, 4.74, 4.74) @ 2441 MHz;
- Sensor-Surface: 3mm (Mechanical Surface Detection)
- Electronics: DAE4 Sn1493; Calibrated: 2023/3/17
- Phantom: Twin SAM; Type: Twin SAM V5.0; Serial: TP:1412
- Measurement SW: DASY52, Version 52.10 (2); SEMCAD X Version 14.6.12 (7470)

Vertical-Back/Bluetooth BDR(GFSK) Mid/Area Scan (11x11x1): Measurement grid: dx=10mm, dy=10mm
Maximum value of SAR (measured) = 0.217 W/kg

Vertical-Back/Bluetooth BDR(GFSK) Mid/Zoom Scan (7x7x7)/Cube 0: Measurement grid: dx=5mm, dy=5mm, dz=5mm

Reference Value = 8.863 V/m; Power Drift = -0.19 dB

Peak SAR (extrapolated) = 0.302 W/kg

SAR(1 g) = 0.153 W/kg; SAR(10 g) = 0.074 W/kg

Maximum value of SAR (measured) = 0.247 W/kg

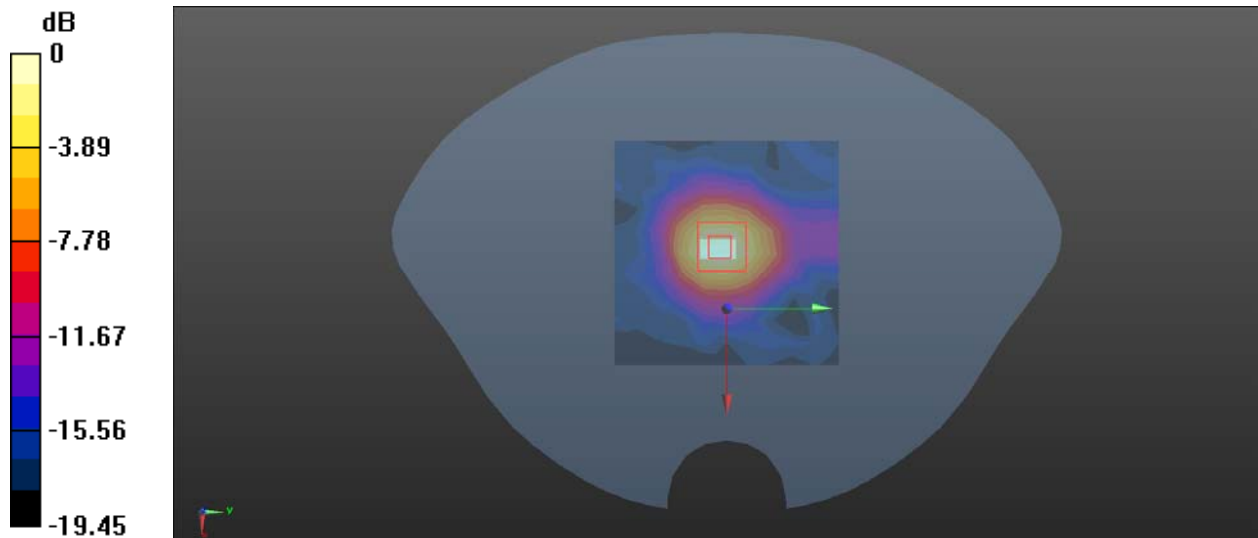

0 dB = 0.247 W/kg = -6.07 dBW/kg

Plot: 7#**DUT: Bluetooth USB Dongle; Type: BT51C; Serial: 2DDC-3**

Communication System: UID 0, Bluetooth(GFSK) (0); Frequency: 2441 MHz; Duty Cycle: 1:1.268
Medium parameters used: $f = 2441$ MHz; $\sigma = 1.83$ S/m; $\epsilon_r = 38.491$; $\rho = 1000$ kg/m³
Phantom section: Flat Section

DASY5 Configuration:

- Probe: ES3DV3 - SN3157; ConvF(4.74, 4.74, 4.74) @ 2441 MHz;
- Sensor-Surface: 3mm (Mechanical Surface Detection)
- Electronics: DAE4 Sn1493; Calibrated: 2023/3/17
- Phantom: Twin SAM; Type: Twin SAM V5.0; Serial: TP:1412
- Measurement SW: DASY52, Version 52.10 (2); SEMCAD X Version 14.6.12 (7470)

Body Top/Bluetooth BDR(GFSK) Mid/Area Scan (11x11x1): Measurement grid: dx=10mm, dy=10mm
Maximum value of SAR (measured) = 0.0387 W/kg

Body Top/Bluetooth BDR(GFSK) Mid/Zoom Scan (7x7x7)/Cube 0: Measurement grid: dx=5mm, dy=5mm, dz=5mm

Reference Value = 3.382 V/m; Power Drift = 0.10 dB

Peak SAR (extrapolated) = 0.0690 W/kg

SAR(1 g) = 0.026 W/kg; SAR(10 g) = 0.014 W/kg

Maximum value of SAR (measured) = 0.0477 W/kg

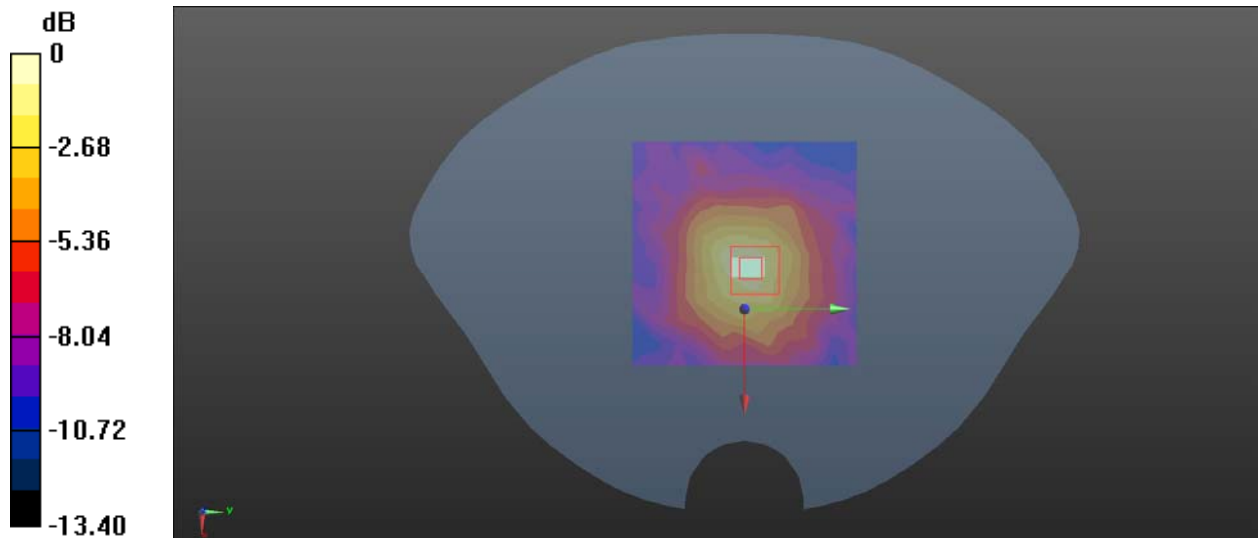

0 dB = 0.0477 W/kg = -13.21 dBW/kg

APPENDIX A MEASUREMENT UNCERTAINTY

The uncertainty budget has been determined for the measurement system and is given in the following Table.

Measurement uncertainty evaluation for IEEE1528-2013 SAR test

| Source of uncertainty | Tolerance/ uncertainty ± % | Probability distribution | Divisor | ci (1 g) | ci (10 g) | Standard uncertainty ± %, (1 g) | Standard uncertainty ± %, (10 g) |
|---|----------------------------------|-----------------------------|------------|-------------|--------------|---------------------------------------|--|
| Measurement system | | | | | | | |
| Probe calibration | 6.55 | N | 1 | 1 | 1 | 6.3 | 6.3 |
| Axial Isotropy | 4.7 | R | $\sqrt{3}$ | 1 | 1 | 2.7 | 2.7 |
| Hemispherical Isotropy | 9.6 | R | $\sqrt{3}$ | 0 | 0 | 0.0 | 0.0 |
| Boundary effect | 1.0 | R | $\sqrt{3}$ | 1 | 1 | 0.6 | 0.6 |
| Linearity | 4.7 | R | $\sqrt{3}$ | 1 | 1 | 2.7 | 2.7 |
| Detection limits | 1.0 | R | $\sqrt{3}$ | 1 | 1 | 0.6 | 0.6 |
| Readout electronics | 0.3 | N | 1 | 1 | 1 | 0.3 | 0.3 |
| Response time | 0.0 | R | $\sqrt{3}$ | 1 | 1 | 0.0 | 0.0 |
| Integration time | 0.0 | R | $\sqrt{3}$ | 1 | 1 | 0.0 | 0.0 |
| RF ambient conditions – noise | 1.0 | R | $\sqrt{3}$ | 1 | 1 | 0.6 | 0.6 |
| RF ambient conditions– reflections | 1.0 | R | $\sqrt{3}$ | 1 | 1 | 0.6 | 0.6 |
| Probe positioner mech. Restrictions | 0.8 | R | $\sqrt{3}$ | 1 | 1 | 0.5 | 0.5 |
| Probe positioning with respect to phantom shell | 6.7 | R | $\sqrt{3}$ | 1 | 1 | 3.9 | 3.9 |
| Post-processing | 2.0 | R | $\sqrt{3}$ | 1 | 1 | 1.2 | 1.2 |
| Test sample related | | | | | | | |
| Test sample positioning | 2.8 | N | 1 | 1 | 1 | 2.8 | 2.8 |
| Device holder uncertainty | 6.3 | N | 1 | 1 | 1 | 6.3 | 6.3 |
| Drift of output power | 5.0 | R | $\sqrt{3}$ | 1 | 1 | 2.9 | 2.9 |
| Phantom and set-up | | | | | | | |
| Phantom uncertainty (shape and thickness tolerances) | 4.0 | R | $\sqrt{3}$ | 1 | 1 | 2.3 | 2.3 |
| Liquid conductivity target) | 5.0 | R | $\sqrt{3}$ | 0.64 | 0.43 | 1.8 | 1.2 |
| Liquid conductivity meas.) | 2.5 | N | 1 | 0.64 | 0.43 | 1.6 | 1.1 |
| Liquid permittivity target) | 5.0 | R | $\sqrt{3}$ | 0.6 | 0.49 | 1.7 | 1.4 |
| Liquid permittivity meas.) | 2.5 | N | 1 | 0.6 | 0.49 | 1.5 | 1.2 |
| Combined standard uncertainty | | RSS | | | | 12.2 | 12.0 |
| Expanded uncertainty 95 % confidence interval) | | | | | | 24.1 | 23.7 |

Measurement uncertainty evaluation for IEC62209-1 SAR test

| Source of uncertainty | Tolerance/uncertainty ± % | Probability distribution | Divisor | ci (1 g) | ci (10 g) | Standard uncertainty ± %, (1 g) | Standard uncertainty ± %, (10 g) |
|--|------------------------------|--------------------------|---------|-------------|--------------|------------------------------------|-------------------------------------|
| Measurement system | | | | | | | |
| Probe calibration | 6.55 | N | 1 | 1 | 1 | 6.3 | 6.3 |
| Axial Isotropy | 4.7 | R | √3 | 1 | 1 | 2.7 | 2.7 |
| Hemispherical Isotropy | 9.6 | R | √3 | 0 | 0 | 0.0 | 0.0 |
| Boundary effect | 1.0 | R | √3 | 1 | 1 | 0.6 | 0.6 |
| Linearity | 4.7 | R | √3 | 1 | 1 | 2.7 | 2.7 |
| Detection limits | 1.0 | R | √3 | 1 | 1 | 0.6 | 0.6 |
| Readout electronics | 0.3 | N | 1 | 1 | 1 | 0.3 | 0.3 |
| Response time | 0.0 | R | √3 | 1 | 1 | 0.0 | 0.0 |
| Integration time | 0.0 | R | √3 | 1 | 1 | 0.0 | 0.0 |
| RF ambient conditions – noise | 1.0 | R | √3 | 1 | 1 | 0.6 | 0.6 |
| Probe positioning with respect to phantom shell | 6.7 | R | √3 | 1 | 1 | 3.9 | 3.9 |
| Probe positioner mech. Restrictions | 0.8 | R | √3 | 1 | 1 | 0.5 | 0.5 |
| RF ambient conditions– reflections | 1.0 | R | √3 | 1 | 1 | 0.6 | 0.6 |
| Post-processing | 2.0 | R | √3 | 1 | 1 | 1.2 | 1.2 |
| Test sample related | | | | | | | |
| Test sample positioning | 2.8 | N | 1 | 1 | 1 | 2.8 | 2.8 |
| Device holder uncertainty | 6.3 | N | 1 | 1 | 1 | 6.3 | 6.3 |
| Drift of output power | 5.0 | R | √3 | 1 | 1 | 2.9 | 2.9 |
| Phantom and set-up | | | | | | | |
| Phantom uncertainty (shape and thickness tolerances) | 4.0 | R | √3 | 1 | 1 | 2.3 | 2.3 |
| Liquid conductivity target) | 5.0 | R | √3 | 0.64 | 0.43 | 1.8 | 1.2 |
| Liquid conductivity meas.) | 2.5 | N | 1 | 0.64 | 0.43 | 1.6 | 1.1 |
| Liquid permittivity target) | 5.0 | R | √3 | 0.6 | 0.49 | 1.7 | 1.4 |
| Liquid permittivity meas.) | 2.5 | N | 1 | 0.6 | 0.49 | 1.5 | 1.2 |
| Combined standard uncertainty | | RSS | | | | 12.2 | 12.0 |
| Expanded uncertainty 95 % confidence interval) | | | | | | 24.0 | 23.6 |

APPENDIX B EUT TEST POSITION PHOTOS

Please Refer to the Attachment.

APPENDIX C PROBE CALIBRATION CERTIFICATES



Add: No.52 HuaYuanBei Road, Haidian District, Beijing, 100191, China
 Tel: +86-10-62304633-2117
 E-mail: cmf@caict.ac.cn http://www.caict.ac.cn



Client **CCICT**

Certificate No: **Z23-60188**

| CALIBRATION CERTIFICATE | | | |
|--|---|--|-----------------------|
| Object | ES3DV3 - SN : 3157 | | |
| Calibration Procedure(s) | FF-Z11-004-02 Calibration Procedures for Dosimetric E-field Probes | | |
| Calibration date: | April 10, 2023 | | |
| <p>This calibration Certificate documents the traceability to national standards, which realize the physical units of measurements(SI). The measurements and the uncertainties with confidence probability are given on the following pages and are part of the certificate.</p> <p>All calibrations have been conducted in the closed laboratory facility: environment temperature(22±3)°C and humidity<70%.</p> <p>Calibration Equipment used (M&TE critical for calibration)</p> | | | |
| Primary Standards | ID # | Cal Date(Calibrated by, Certificate No.) | Scheduled Calibration |
| Power Meter NRP2 | 101919 | 14-Jun-22(CTTL, No.J22X04181) | Jun-23 |
| Power sensor NRP-Z91 | 101547 | 14-Jun-22(CTTL, No.J22X04181) | Jun-23 |
| Power sensor NRP-Z91 | 101548 | 14-Jun-22(CTTL, No.J22X04181) | Jun-23 |
| Reference 10dBAAttenuator | 18N50W-10dB | 19-Jan-23(CTTL, No.J23X00212) | Jan-25 |
| Reference 20dBAAttenuator | 18N50W-20dB | 19-Jan-23(CTTL, No.J23X00211) | Jan-25 |
| Reference Probe EX3DV4 | SN 3846 | 20-May-22(SPEAG, No.EX3-3846_May22) | May-23 |
| DAE4 | SN 1555 | 25-Aug-22(SPEAG, No.DAE4-1555_Aug22) | Aug-23 |
| DAE4 | SN 549 | 24-Jan-23(SPEAG, No.DAE4-549_Jan23) | Jan-24 |
| Secondary Standards | ID # | Cal Date(Calibrated by, Certificate No.) | Scheduled Calibration |
| SignalGenerator MG3700A | 6201052605 | 14-Jun-22(CTTL, No.J22X04182) | Jun-23 |
| Network Analyzer E5071C | MY46110673 | 10-Jan-23(CTTL, No.J23X00104) | Jan-24 |
| Calibrated by: | Name Yu Zongying | Function SAR Test Engineer | Signature |
| Reviewed by: | Lin Hao | SAR Test Engineer | |
| Approved by: | Qi Dianyuan | SAR Project Leader | |
| Issued: April 15, 2023 | | | |
| This calibration certificate shall not be reproduced except in full without written approval of the laboratory. | | | |



Add: No.52 HuaYuanBei Road, Haidian District, Beijing, 100191, China
 Tel: +86-10-62304633-2117
 E-mail: emf@caict.ac.cn http://www.caict.ac.cn

Glossary:

| | |
|-----------------------|---|
| TSL | tissue simulating liquid |
| NORM _{x,y,z} | sensitivity in free space |
| ConvF | sensitivity in TSL / NORM _{x,y,z} |
| DCP | diode compression point |
| CF | crest factor (1/duty_cycle) of the RF signal |
| A,B,C,D | modulation dependent linearization parameters |
| Polarization Φ | Φ rotation around probe axis |
| Polarization θ | θ rotation around an axis that is in the plane normal to probe axis (at measurement center), i $\theta=0$ is normal to probe axis |

Connector Angle information used in DASY system to align probe sensor X to the robot coordinate system

Calibration is Performed According to the Following Standards:

- IEEE Std 1528-2013, "IEEE Recommended Practice for Determining the Peak Spatial-Averaged Specific Absorption Rate (SAR) in the Human Head from Wireless Communications Devices: Measurement Techniques", June 2013
- IEC 62209-1, "Measurement procedure for the assessment of Specific Absorption Rate (SAR) from hand-held and body-mounted devices used next to the ear (frequency range of 300 MHz to 6 GHz)", July 2016
- IEC 62209-2, "Procedure to determine the Specific Absorption Rate (SAR) for wireless communication devices used in close proximity to the human body (frequency range of 30 MHz to 6 GHz)", March 2010
- KDB 865664, "SAR Measurement Requirements for 100 MHz to 6 GHz"

Methods Applied and Interpretation of Parameters:

- NORM_{x,y,z}: Assessed for E-field polarization $\theta=0$ ($f \leq 900$ MHz in TEM-cell; $f > 1800$ MHz: waveguide). NORM_{x,y,z} are only intermediate values, i.e., the uncertainties of NORM_{x,y,z} does not effect the E^2 -field uncertainty inside TSL (see below ConvF).
- NORM(f)_{x,y,z} = NORM_{x,y,z} * frequency_response (see Frequency Response Chart). This linearization is implemented in DASY4 software versions later than 4.2. The uncertainty of the frequency response is included in the stated uncertainty of ConvF.
- DCP_{x,y,z}: DCP are numerical linearization parameters assessed based on the data of power sweep (no uncertainty required). DCP does not depend on frequency nor media.
- PAR: PAR is the Peak to Average Ratio that is not calibrated but determined based on the signal characteristics.
- A_{x,y,z}; B_{x,y,z}; C_{x,y,z}; VR_{x,y,z}; A,B,C are numerical linearization parameters assessed based on the data of power sweep for specific modulation signal. The parameters do not depend on frequency nor media. VR is the maximum calibration range expressed in RMS voltage across the diode.
- ConvF and Boundary Effect Parameters: Assessed in flat phantom using E-field (or Temperature Transfer Standard for $f \leq 800$ MHz) and inside waveguide using analytical field distributions based on power measurements for $f > 800$ MHz. The same setups are used for assessment of the parameters applied for boundary compensation (alpha, depth) of which typical uncertainty valued are given. These parameters are used in DASY4 software to improve probe accuracy close to the boundary. The sensitivity in TSL corresponds to NORM_{x,y,z} * ConvF whereby the uncertainty corresponds to that given for ConvF. A frequency dependent ConvF is used in DASY version 4.4 and higher which allows extending the validity from ± 50 MHz to ± 100 MHz.
- Spherical isotropy (3D deviation from isotropy): in a field of low gradients realized using a flat phantom exposed by a patch antenna.
- Sensor Offset: The sensor offset corresponds to the offset of virtual measurement center from the probe tip (on probe axis). No tolerance required.
- Connector Angle: The angle is assessed using the information gained by determining the NORM_x (no uncertainty required).



Add: No.52 HuaYuanBei Road, Haidian District, Beijing, 100191, China
 Tel: +86-10-62304633-2117
 E-mail: emf@caict.ac.cn http://www.caict.ac.cn

DASY/EASY – Parameters of Probe: ES3DV3 – SN:3157

Basic Calibration Parameters

| | Sensor X | Sensor Y | Sensor Z | Unc (k=2) |
|--|----------|----------|----------|--------------|
| Norm($\mu\text{V}/(\text{V}/\text{m})^2$) ^A | 0.97 | 1.14 | 0.96 | $\pm 10.0\%$ |
| DCP(mV) ^B | 102.2 | 102.6 | 103.6 | |

Modulation Calibration Parameters

| UID | Communication System Name | | A dB | B dB $\sqrt{\mu\text{V}}$ | C | D dB | VR mV | Unc ^E (k=2) |
|-----|---------------------------|---|------|---------------------------|-----|------|-------|------------------------|
| 0 | CW | X | 0.0 | 0.0 | 1.0 | 0.00 | 224.4 | $\pm 2.0\%$ |
| | | Y | 0.0 | 0.0 | 1.0 | | 247.0 | |
| | | Z | 0.0 | 0.0 | 1.0 | | 223.9 | |

The reported uncertainty of measurement is stated as the standard uncertainty of Measurement multiplied by the coverage factor $k=2$, which for a normal distribution Corresponds to a coverage probability of approximately 95%.

^A The uncertainties of Norm X, Y, Z do not affect the E²-field uncertainty inside TSL (see Page 4).

^B Numerical linearization parameter: uncertainty not required.

^E Uncertainty is determined using the max. deviation from linear response applying rectangular distribution and is expressed for the square of the field value.



Add: No.52 HuaYuanBei Road, Haidian District, Beijing, 100191, China
Tel: +86-10-62304633-2117
E-mail: emf@caict.ac.cn http://www.caict.ac.cn

DASY/EASY – Parameters of Probe: ES3DV3 – SN:3157

Calibration Parameter Determined in Head Tissue Simulating Media

| f [MHz] ^C | Relative Permittivity ^F | Conductivity (S/m) ^F | ConvF X | ConvF Y | ConvF Z | Alpha ^G | Depth ^G (mm) | Unct. (k=2) |
|----------------------|------------------------------------|---------------------------------|---------|---------|---------|--------------------|-------------------------|-------------|
| 750 | 41.9 | 0.89 | 6.48 | 6.48 | 6.48 | 0.35 | 1.53 | ±12.7% |
| 900 | 41.5 | 0.97 | 6.25 | 6.25 | 6.25 | 0.37 | 1.53 | ±12.7% |
| 1750 | 40.1 | 1.37 | 5.38 | 5.38 | 5.38 | 0.60 | 1.31 | ±12.7% |
| 1900 | 40.0 | 1.40 | 5.18 | 5.18 | 5.18 | 0.65 | 1.26 | ±12.7% |
| 2300 | 39.5 | 1.67 | 4.96 | 4.96 | 4.96 | 0.90 | 1.10 | ±12.7% |
| 2450 | 39.2 | 1.80 | 4.74 | 4.74 | 4.74 | 0.90 | 1.10 | ±12.7% |
| 2600 | 39.0 | 1.96 | 4.52 | 4.52 | 4.52 | 0.90 | 1.16 | ±12.7% |

^C Frequency validity above 300 MHz of ±100MHz only applies for DASY v4.4 and higher (Page 2), else it is restricted to ±50MHz. The uncertainty is the RSS of ConvF uncertainty at calibration frequency and the uncertainty for the indicated frequency band. Frequency validity below 300 MHz is ± 10, 25, 40, 50 and 70 MHz for ConvF assessments at 30, 64, 128, 150 and 220 MHz respectively. Above 5 GHz frequency validity can be extended to ± 110 MHz.

^F At frequency up to 6 GHz, the validity of tissue parameters (ϵ and σ) can be relaxed to ±10% if liquid compensation formula is applied to measured SAR values. The uncertainty is the RSS of the ConvF uncertainty for indicated target tissue parameters.

^G Alpha/Depth are determined during calibration. SPEAG warrants that the remaining deviation due to the boundary effect after compensation is always less than ± 1% for frequencies below 3 GHz and below ± 2% for the frequencies between 3-6 GHz at any distance larger than half the probe tip diameter from the boundary.



Add: No.52 HuaYuanBei Road, Haidian District, Beijing, 100191, China
Tel: +86-10-62304633-2117
E-mail: emf@caict.ac.cn <http://www.caict.ac.cn>

Frequency Response of E-Field (TEM-Cell: ifi110 EXX, Waveguide: R22)

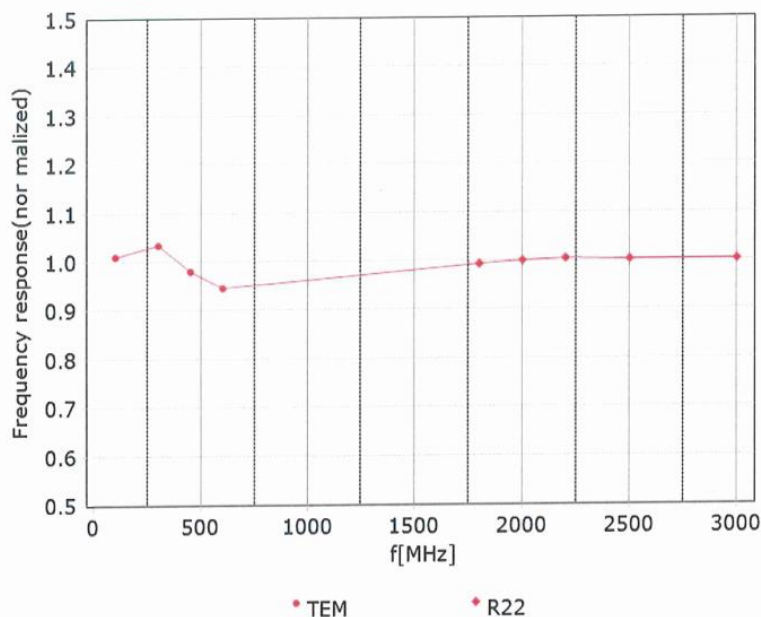

Uncertainty of Frequency Response of E-field: $\pm 7.4\%$ ($k=2$)



Add: No.52 HuaYuanBei Road, Haidian District, Beijing, 100191, China
Tel: +86-10-62304633-2117
E-mail: emf@caict.ac.cn <http://www.caict.ac.cn>

Receiving Pattern (Φ), $\theta=0^\circ$

f=600 MHz, TEM

f=1800 MHz, R22

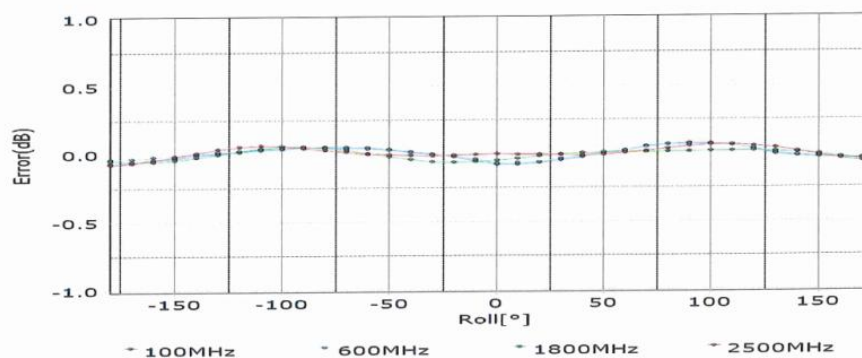
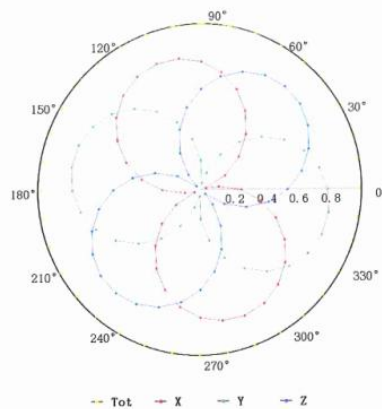
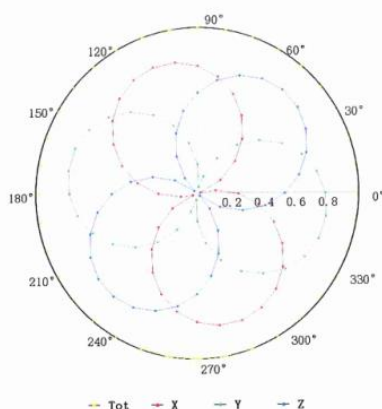

Uncertainty of Axial Isotropy Assessment: $\pm 1.2\%$ ($k=2$)



Add: No.52 HuaYuanBei Road, Haidian District, Beijing, 100191, China
 Tel: +86-10-62304633-2117
 E-mail: emf@caict.ac.cn http://www.caict.ac.cn

Dynamic Range f(SAR_{head}) (TEM cell, f = 900 MHz)

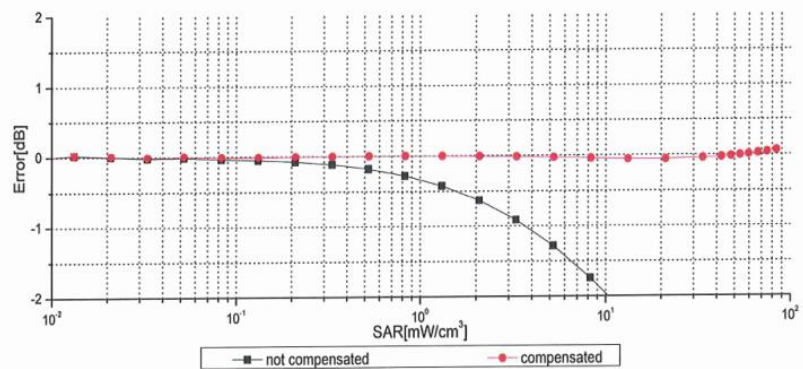
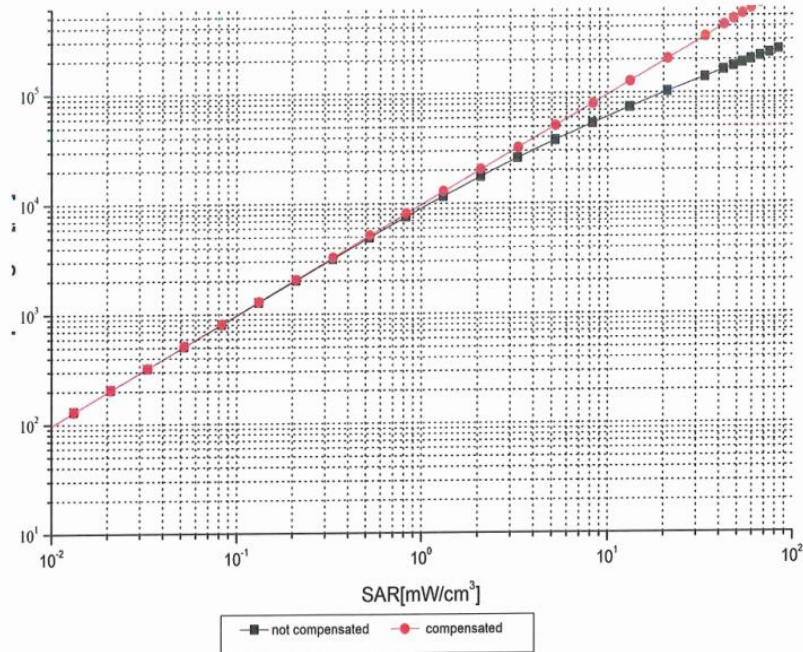

Uncertainty of Linearity Assessment: ±0.9% (k=2)



Add: No.52 HuaYuanBei Road, Haidian District, Beijing, 100191, China
 Tel: +86-10-62304633-2117
 E-mail: emf@caict.ac.cn http://www.caict.ac.cn

Conversion Factor Assessment

f=750 MHz,WGLS R9(H_convF)

f=1750 MHz,WGLS R22(H_convF)

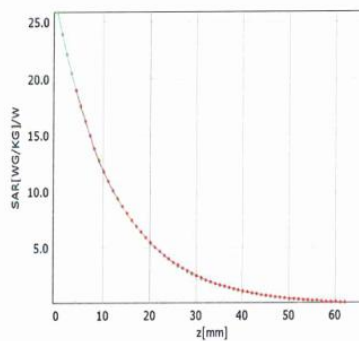
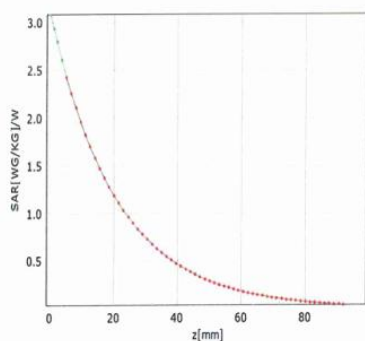

Deviation from Isotropy in Liquid

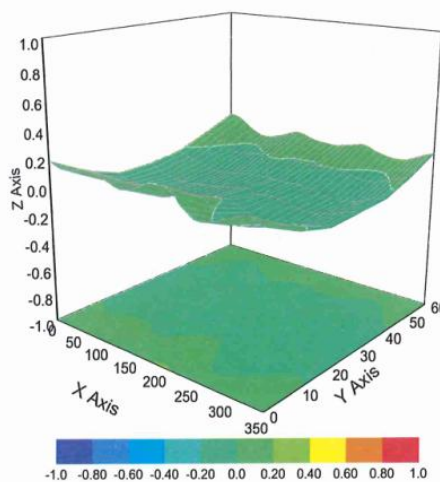

Uncertainty of Spherical Isotropy Assessment: $\pm 3.2\%$ ($k=2$)



Add: No.52 HuaYuanBei Road, Haidian District, Beijing, 100191, China
Tel: +86-10-62304633-2117
E-mail: emf@caict.ac.cn <http://www.caict.ac.cn>

DASY/EASY – Parameters of Probe: ES3DV3 – SN:3157

Other Probe Parameters

| | |
|---|------------|
| Sensor Arrangement | Triangular |
| Connector Angle (°) | 56.2 |
| Mechanical Surface Detection Mode | enabled |
| Optical Surface Detection Mode | disable |
| Probe Overall Length | 337mm |
| Probe Body Diameter | 10mm |
| Tip Length | 10mm |
| Tip Diameter | 4mm |
| Probe Tip to Sensor X Calibration Point | 2mm |
| Probe Tip to Sensor Y Calibration Point | 2mm |
| Probe Tip to Sensor Z Calibration Point | 2mm |
| Recommended Measurement Distance from Surface | 3mm |

APPENDIX D DIPOLE CALIBRATION CERTIFICATES

**Calibration Laboratory of
Schmid & Partner
Engineering AG**
Zeughausstrasse 43, 8004 Zurich, Switzerland



S Schweizerischer Kalibrierdienst
C Service suisse d'étalonnage
S Servizio svizzero di taratura
S Swiss Calibration Service

Accredited by the Swiss Accreditation Service (SAS)
The Swiss Accreditation Service is one of the signatories to the EA
Multilateral Agreement for the recognition of calibration certificates

Accreditation No.: **SCS 0108**

Client **BACL**
Sunnyvale, USA

Certificate No. **D2450V2-1102_Mar23**

| CALIBRATION CERTIFICATE | | | | | | | | | | | | | | | | | | | | | | | | | | | | | | | | | | | | | | | | | | | | | | | | | | | | | | | | | | | |
|---|---|-----------------------------------|------------------------|-------------------|------|----------------------------|-----------------------|-----------------|------------|---------------------------------|--------|----------------------|------------|---------------------------|--------|----------------------|------------|---------------------------|--------|----------------------------|------------------|---------------------------|--------|-----------------------------|--------------------|---------------------------|--------|------------------------|----------|--------------------------------|--------|------|---------|--------------------------------|--------|---------------------|------|-----------------------|-----------------|--------------------|----------------|-----------------------------------|------------------------|-----------------------|----------------|-----------------------------------|------------------------|-----------------------|----------------|-----------------------------------|------------------------|-------------------------|------------|-----------------------------------|------------------------|---------------------------------|----------------|-----------------------------------|------------------------|
| Object | D2450V2 - SN:1102 | | | | | | | | | | | | | | | | | | | | | | | | | | | | | | | | | | | | | | | | | | | | | | | | | | | | | | | | | | |
| Calibration procedure(s) | QA CAL-05.v12 Calibration Procedure for SAR Validation Sources between 0.7-3 GHz | | | | | | | | | | | | | | | | | | | | | | | | | | | | | | | | | | | | | | | | | | | | | | | | | | | | | | | | | | |
| Calibration date: | March 27, 2023 | | | | | | | | | | | | | | | | | | | | | | | | | | | | | | | | | | | | | | | | | | | | | | | | | | | | | | | | | | |
| <p>This calibration certificate documents the traceability to national standards, which realize the physical units of measurements (SI). The measurements and the uncertainties with confidence probability are given on the following pages and are part of the certificate.</p> <p>All calibrations have been conducted in the closed laboratory facility: environment temperature (22 ± 3)°C and humidity < 70%.</p> <p>Calibration Equipment used (M&TE critical for calibration)</p> <table border="1"> <thead> <tr> <th>Primary Standards</th> <th>ID #</th> <th>Cal Date (Certificate No.)</th> <th>Scheduled Calibration</th> </tr> </thead> <tbody> <tr> <td>Power meter NRP</td> <td>SN: 104778</td> <td>04-Apr-22 (No. 217-03525/03524)</td> <td>Apr-23</td> </tr> <tr> <td>Power sensor NRP-Z91</td> <td>SN: 103244</td> <td>04-Apr-22 (No. 217-03524)</td> <td>Apr-23</td> </tr> <tr> <td>Power sensor NRP-Z91</td> <td>SN: 103245</td> <td>04-Apr-22 (No. 217-03525)</td> <td>Apr-23</td> </tr> <tr> <td>Reference 20 dB Attenuator</td> <td>SN: BH9394 (20k)</td> <td>04-Apr-22 (No. 217-03527)</td> <td>Apr-23</td> </tr> <tr> <td>Type-N mismatch combination</td> <td>SN: 310982 / 06327</td> <td>04-Apr-22 (No. 217-03528)</td> <td>Apr-23</td> </tr> <tr> <td>Reference Probe EX3DV4</td> <td>SN: 7349</td> <td>10-Jan-23 (No. EX3-7349_Jan23)</td> <td>Jan-24</td> </tr> <tr> <td>DAE4</td> <td>SN: 601</td> <td>19-Dec-22 (No. DAE4-601_Dec22)</td> <td>Dec-23</td> </tr> </tbody> </table> <table border="1"> <thead> <tr> <th>Secondary Standards</th> <th>ID #</th> <th>Check Date (in house)</th> <th>Scheduled Check</th> </tr> </thead> <tbody> <tr> <td>Power meter E4419B</td> <td>SN: GB39512475</td> <td>30-Oct-14 (in house check Oct-22)</td> <td>In house check: Oct-24</td> </tr> <tr> <td>Power sensor HP 8481A</td> <td>SN: US37292783</td> <td>07-Oct-15 (in house check Oct-22)</td> <td>In house check: Oct-24</td> </tr> <tr> <td>Power sensor HP 8481A</td> <td>SN: MY41093315</td> <td>07-Oct-15 (in house check Oct-22)</td> <td>In house check: Oct-24</td> </tr> <tr> <td>RF generator R&S SMT-06</td> <td>SN: 100972</td> <td>15-Jun-15 (in house check Oct-22)</td> <td>In house check: Oct-24</td> </tr> <tr> <td>Network Analyzer Agilent E8358A</td> <td>SN: US41080477</td> <td>31-Mar-14 (in house check Oct-22)</td> <td>In house check: Oct-24</td> </tr> </tbody> </table> | | | | Primary Standards | ID # | Cal Date (Certificate No.) | Scheduled Calibration | Power meter NRP | SN: 104778 | 04-Apr-22 (No. 217-03525/03524) | Apr-23 | Power sensor NRP-Z91 | SN: 103244 | 04-Apr-22 (No. 217-03524) | Apr-23 | Power sensor NRP-Z91 | SN: 103245 | 04-Apr-22 (No. 217-03525) | Apr-23 | Reference 20 dB Attenuator | SN: BH9394 (20k) | 04-Apr-22 (No. 217-03527) | Apr-23 | Type-N mismatch combination | SN: 310982 / 06327 | 04-Apr-22 (No. 217-03528) | Apr-23 | Reference Probe EX3DV4 | SN: 7349 | 10-Jan-23 (No. EX3-7349_Jan23) | Jan-24 | DAE4 | SN: 601 | 19-Dec-22 (No. DAE4-601_Dec22) | Dec-23 | Secondary Standards | ID # | Check Date (in house) | Scheduled Check | Power meter E4419B | SN: GB39512475 | 30-Oct-14 (in house check Oct-22) | In house check: Oct-24 | Power sensor HP 8481A | SN: US37292783 | 07-Oct-15 (in house check Oct-22) | In house check: Oct-24 | Power sensor HP 8481A | SN: MY41093315 | 07-Oct-15 (in house check Oct-22) | In house check: Oct-24 | RF generator R&S SMT-06 | SN: 100972 | 15-Jun-15 (in house check Oct-22) | In house check: Oct-24 | Network Analyzer Agilent E8358A | SN: US41080477 | 31-Mar-14 (in house check Oct-22) | In house check: Oct-24 |
| Primary Standards | ID # | Cal Date (Certificate No.) | Scheduled Calibration | | | | | | | | | | | | | | | | | | | | | | | | | | | | | | | | | | | | | | | | | | | | | | | | | | | | | | | | |
| Power meter NRP | SN: 104778 | 04-Apr-22 (No. 217-03525/03524) | Apr-23 | | | | | | | | | | | | | | | | | | | | | | | | | | | | | | | | | | | | | | | | | | | | | | | | | | | | | | | | |
| Power sensor NRP-Z91 | SN: 103244 | 04-Apr-22 (No. 217-03524) | Apr-23 | | | | | | | | | | | | | | | | | | | | | | | | | | | | | | | | | | | | | | | | | | | | | | | | | | | | | | | | |
| Power sensor NRP-Z91 | SN: 103245 | 04-Apr-22 (No. 217-03525) | Apr-23 | | | | | | | | | | | | | | | | | | | | | | | | | | | | | | | | | | | | | | | | | | | | | | | | | | | | | | | | |
| Reference 20 dB Attenuator | SN: BH9394 (20k) | 04-Apr-22 (No. 217-03527) | Apr-23 | | | | | | | | | | | | | | | | | | | | | | | | | | | | | | | | | | | | | | | | | | | | | | | | | | | | | | | | |
| Type-N mismatch combination | SN: 310982 / 06327 | 04-Apr-22 (No. 217-03528) | Apr-23 | | | | | | | | | | | | | | | | | | | | | | | | | | | | | | | | | | | | | | | | | | | | | | | | | | | | | | | | |
| Reference Probe EX3DV4 | SN: 7349 | 10-Jan-23 (No. EX3-7349_Jan23) | Jan-24 | | | | | | | | | | | | | | | | | | | | | | | | | | | | | | | | | | | | | | | | | | | | | | | | | | | | | | | | |
| DAE4 | SN: 601 | 19-Dec-22 (No. DAE4-601_Dec22) | Dec-23 | | | | | | | | | | | | | | | | | | | | | | | | | | | | | | | | | | | | | | | | | | | | | | | | | | | | | | | | |
| Secondary Standards | ID # | Check Date (in house) | Scheduled Check | | | | | | | | | | | | | | | | | | | | | | | | | | | | | | | | | | | | | | | | | | | | | | | | | | | | | | | | |
| Power meter E4419B | SN: GB39512475 | 30-Oct-14 (in house check Oct-22) | In house check: Oct-24 | | | | | | | | | | | | | | | | | | | | | | | | | | | | | | | | | | | | | | | | | | | | | | | | | | | | | | | | |
| Power sensor HP 8481A | SN: US37292783 | 07-Oct-15 (in house check Oct-22) | In house check: Oct-24 | | | | | | | | | | | | | | | | | | | | | | | | | | | | | | | | | | | | | | | | | | | | | | | | | | | | | | | | |
| Power sensor HP 8481A | SN: MY41093315 | 07-Oct-15 (in house check Oct-22) | In house check: Oct-24 | | | | | | | | | | | | | | | | | | | | | | | | | | | | | | | | | | | | | | | | | | | | | | | | | | | | | | | | |
| RF generator R&S SMT-06 | SN: 100972 | 15-Jun-15 (in house check Oct-22) | In house check: Oct-24 | | | | | | | | | | | | | | | | | | | | | | | | | | | | | | | | | | | | | | | | | | | | | | | | | | | | | | | | |
| Network Analyzer Agilent E8358A | SN: US41080477 | 31-Mar-14 (in house check Oct-22) | In house check: Oct-24 | | | | | | | | | | | | | | | | | | | | | | | | | | | | | | | | | | | | | | | | | | | | | | | | | | | | | | | | |
| Calibrated by: | Name Jeton Kastrati | Function Laboratory Technician | Signature | | | | | | | | | | | | | | | | | | | | | | | | | | | | | | | | | | | | | | | | | | | | | | | | | | | | | | | | |
| Approved by: | Sven Kühn | Technical Manager | | | | | | | | | | | | | | | | | | | | | | | | | | | | | | | | | | | | | | | | | | | | | | | | | | | | | | | | | |
| | | | Issued: March 27, 2023 | | | | | | | | | | | | | | | | | | | | | | | | | | | | | | | | | | | | | | | | | | | | | | | | | | | | | | | | |
| This calibration certificate shall not be reproduced except in full without written approval of the laboratory. | | | | | | | | | | | | | | | | | | | | | | | | | | | | | | | | | | | | | | | | | | | | | | | | | | | | | | | | | | | |

Calibration Laboratory of
Schmid & Partner
Engineering AG
Zeughausstrasse 43, 8004 Zurich, Switzerland



S Schweizerischer Kalibrierdienst
C Service suisse d'étalonnage
S Servizio svizzero di taratura
S Swiss Calibration Service

Accreditation No.: **SCS 0108**

Accredited by the Swiss Accreditation Service (SAS)
The Swiss Accreditation Service is one of the signatories to the EA
Multilateral Agreement for the recognition of calibration certificates

Glossary:

TSL tissue simulating liquid
ConvF sensitivity in TSL / NORM x,y,z
N/A not applicable or not measured

Calibration is Performed According to the Following Standards:

- a) IEC/IEEE 62209-1528, "Measurement Procedure For The Assessment Of Specific Absorption Rate Of Human Exposure To Radio Frequency Fields From Hand-Held And Body-Worn Wireless Communication Devices - Part 1528: Human Models, Instrumentation And Procedures (Frequency Range of 4 MHz to 10 GHz)", October 2020.
- b) KDB 865664, "SAR Measurement Requirements for 100 MHz to 6 GHz"

Additional Documentation:

- c) DASY System Handbook

Methods Applied and Interpretation of Parameters:

- *Measurement Conditions:* Further details are available from the Validation Report at the end of the certificate. All figures stated in the certificate are valid at the frequency indicated.
- *Antenna Parameters with TSL:* The source is mounted in a touch configuration below the center marking of the flat phantom.
- *Return Loss:* This parameter is measured with the source positioned under the liquid filled phantom (as described in the measurement condition clause). The Return Loss ensures low reflected power. No uncertainty required.
- *SAR measured:* SAR measured at the stated antenna input power.
- *SAR normalized:* SAR as measured, normalized to an input power of 1 W at the antenna connector.
- *SAR for nominal TSL parameters:* The measured TSL parameters are used to calculate the nominal SAR result.

The reported uncertainty of measurement is stated as the standard uncertainty of measurement multiplied by the coverage factor $k=2$, which for a normal distribution corresponds to a coverage probability of approximately 95%.

Measurement Conditions

DASY system configuration, as far as not given on page 1.

| | | |
|------------------------------|------------------------|-------------|
| DASY Version | DASY52 | V52.10.4 |
| Extrapolation | Advanced Extrapolation | |
| Phantom | Modular Flat Phantom | |
| Distance Dipole Center - TSL | 10 mm | with Spacer |
| Zoom Scan Resolution | dx, dy, dz = 5 mm | |
| Frequency | 2450 MHz \pm 1 MHz | |

Head TSL parameters

The following parameters and calculations were applied.

| | Temperature | Permittivity | Conductivity |
|---|---------------------|----------------|----------------------|
| Nominal Head TSL parameters | 22.0 °C | 39.2 | 1.80 mho/m |
| Measured Head TSL parameters | (22.0 \pm 0.2) °C | 38.0 \pm 6 % | 1.81 mho/m \pm 6 % |
| Head TSL temperature change during test | < 0.5 °C | ---- | ---- |

SAR result with Head TSL

| SAR averaged over 1 cm ³ (1 g) of Head TSL | Condition | |
|---|--------------------|--|
| SAR measured | 250 mW input power | 12.9 W/kg |
| SAR for nominal Head TSL parameters | normalized to 1W | 50.9 W/kg \pm 17.0 % (k=2) |

| SAR averaged over 10 cm ³ (10 g) of Head TSL | condition | |
|---|--------------------|--|
| SAR measured | 250 mW input power | 6.07 W/kg |
| SAR for nominal Head TSL parameters | normalized to 1W | 24.1 W/kg \pm 16.5 % (k=2) |

Appendix (Additional assessments outside the scope of SCS 0108)**Antenna Parameters with Head TSL**

| | |
|--------------------------------------|--------------------------------|
| Impedance, transformed to feed point | 53.9 Ω + 4.8 j Ω |
| Return Loss | - 24.6 dB |

General Antenna Parameters and Design

| | |
|----------------------------------|----------|
| Electrical Delay (one direction) | 1.155 ns |
|----------------------------------|----------|

After long term use with 100W radiated power, only a slight warming of the dipole near the feedpoint can be measured.

The dipole is made of standard semirigid coaxial cable. The center conductor of the feeding line is directly connected to the second arm of the dipole. The antenna is therefore short-circuited for DC-signals. On some of the dipoles, small end caps are added to the dipole arms in order to improve matching when loaded according to the position as explained in the "Measurement Conditions" paragraph. The SAR data are not affected by this change. The overall dipole length is still according to the Standard.

No excessive force must be applied to the dipole arms, because they might bend or the soldered connections near the feedpoint may be damaged.

Additional EUT Data

| | |
|-----------------|-------|
| Manufactured by | SPEAG |
|-----------------|-------|

DASY5 Validation Report for Head TSL

Date: 27.03.2023

Test Laboratory: SPEAG, Zurich, Switzerland

DUT: Dipole 2450 MHz; Type: D2450V2; Serial: D2450V2 - SN:1102

Communication System: UID 0 - CW; Frequency: 2450 MHz

Medium parameters used: $f = 2450$ MHz; $\sigma = 1.81$ S/m; $\epsilon_r = 38$; $\rho = 1000$ kg/m³

Phantom section: Flat Section

Measurement Standard: DASY5 (IEEE/IEC/ANSI C63.19-2011)

DASY52 Configuration:

- Probe: EX3DV4 - SN7349; ConvF(7.88, 7.88, 7.88) @ 2450 MHz; Calibrated: 10.01.2023
- Sensor-Surface: 1.4mm (Mechanical Surface Detection)
- Electronics: DAE4 Sn601; Calibrated: 19.12.2022
- Phantom: Flat Phantom 5.0 (front); Type: QD 000 P50 AA; Serial: 1001
- DASY52 52.10.4(1535); SEMCAD X 14.6.14(7501)

Dipole Calibration for Head Tissue/Pin=250 mW, d=10mm/Zoom Scan (7x7x7)/Cube 0:

Measurement grid: dx=5mm, dy=5mm, dz=5mm

Reference Value = 115.0 V/m; Power Drift = -0.01 dB

Peak SAR (extrapolated) = 24.7 W/kg

SAR(1 g) = 12.9 W/kg; SAR(10 g) = 6.07 W/kg

Smallest distance from peaks to all points 3 dB below = 9 mm

Ratio of SAR at M2 to SAR at M1 = 51.9%

Maximum value of SAR (measured) = 20.7 W/kg

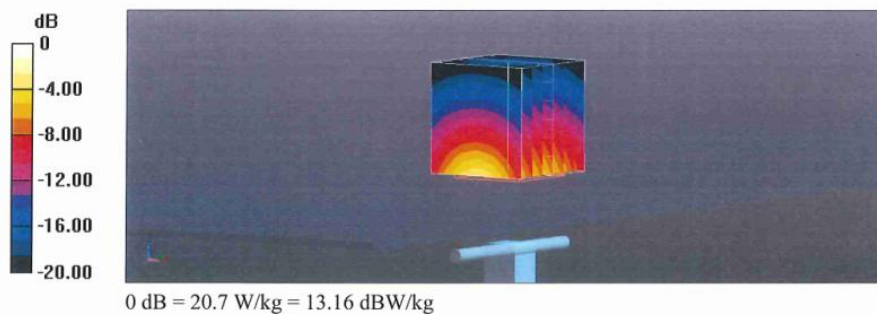

Impedance Measurement Plot for Head TSL

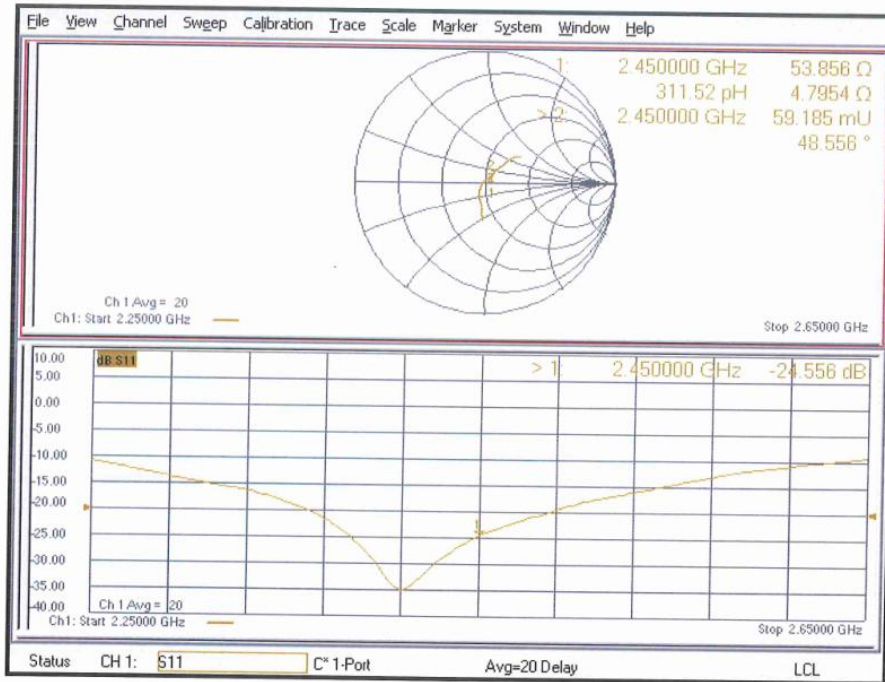

***** END OF REPORT *****