

TCM 515B – 2.4 GHZ BLUETOOTH LOW ENERGY (BLE) Transceiver

12 November 2019



Observe precautions! Electrostatic sensitive devices!

Patent protected:
WO98/36395, DE 100 25 561, DE 101 50 128,
WO 2004/051591, DE 103 01 678 A1, DE 10309334,
WO 04/109236, WO 05/096482, WO 02/095707,
US 6,747,573, US 7,019,241

TCM 515B – 2.4 GHZ BLUETOOTH LOW ENERGY (BLE) Transceiver

REVISION HISTORY

The following major modifications and improvements have been made to this document:

Version	Author	Reviewer	Date	Major Changes
0.1	MKA	MKA	15.02.2017	Initial Release
0.2	MKA	MKA	14.07.2017	Update regarding operation conditions
0.3	MKA	MKA	19.09.2017	Added detailed pin mapping
0.4	RS	MKA	19.09.2017	Added antenna options and descriptions
0.5	RS	MKA	05.10.2017	Added FCC labelling requirements, RF exposure and distance requirements, FCC and ISED certificates
0.6	RS		14.12.2017	Updated chapters to RF exposure
1.0	MKA	MKA	12.11.2019	Updated antenna list

**Published by EnOcean GmbH, Kolpingring 18a, 82041 Oberhaching, Germany
 www.enocean.com, info@enocean.com, phone +49 (89) 6734 6890**

© EnOcean GmbH, All Rights Reserved

Important!

This information describes the type of component and shall not be considered as assured characteristics. No responsibility is assumed for possible omissions or inaccuracies. Circuitry and specifications are subject to change without notice. For the latest product specifications, refer to the EnOcean website: <http://www.enocean.com>.

As far as patents or other rights of third parties are concerned, liability is only assumed for modules, not for the described applications, processes and circuits.

EnOcean does not assume responsibility for use of modules described and limits its liability to the replacement of modules determined to be defective due to workmanship. Devices or systems containing RF components must meet the essential requirements of the local legal authorities.

The modules must not be used in any relation with equipment that supports, directly or indirectly, human health or life or with applications that can result in danger for people, animals or real value.

Components of the modules are considered and should be disposed of as hazardous waste. Local government regulations are to be observed.

Packing: Please use the recycling operators known to you.

TCM 515B – 2.4 GHZ BLUETOOTH LOW ENERGY (BLE) Transceiver

TABLE OF CONTENT

1	General Description	5
1.1	Basic functionality	5
1.2	Technical data.....	6
1.3	Physical dimensions.....	6
1.4	Environmental conditions	6
1.5	Packaging information.....	6
1.6	Ordering information	6
2	Functional Information	7
2.1	TCM 515B Device Interface.....	7
2.1.1	Signal Description	8
2.2	High-level operation principle.....	8
2.3	Radio functionality.....	9
2.4	Radio transmission sequence	10
2.5	Radio reception sequence	10
2.6	User-defined radio channels.....	10
2.7	Data rate.....	10
3	Telegram format	11
3.1	Preamble.....	11
3.2	Access Address	11
3.3	Header.....	11
3.4	Source address	12
3.4.1	Static source address mode	12
3.4.2	Private resolvable source address mode	13
3.5	Check Sum	14
3.6	Payload	15
3.7	Sensor status encoding	16
3.7.1	Sensor Data Descriptor.....	16
3.7.2	Sensor Status.....	17
3.8	TCM 515B telegram authentication	18
3.9	ESP3 Interface	19
3.9.1	ESP3 Data Format.....	19
4	Antenna Options	20
4.1	General antenna requirements for TCM 515B	20
4.2	European Union.....	20
4.3	US / Canada	21
4.3.1	Whip Antenna.....	21
4.3.1.1	Whip Antenna Parameters.....	21
4.3.1.2	Whip Antenna Reference Layout	22
4.3.1.1	Whip Antenna Transmission Line.....	22
4.3.2	Meandered PCB Antenna.....	23
4.3.2.1	Meandered PCB Antenna Layout	23

TCM 515B – 2.4 GHZ BLUETOOTH LOW ENERGY (BLE) Transceiver

4.3.2.2	Meandered PCB Antenna PCB Stack.....	24
4.3.2.3	Meandered PCB Antenna Matching	24
4.3.3	Dipole Antennae	25
4.3.3.1	Dipole PCB Antenna Layout	26
4.3.3.2	Dipole PCB Antenna Connector	26
4.3.3.3	Dipole Antenna PCB Stack.....	27
4.3.3.4	Dipole Antenna Examples.....	28
5	Device Integration	29
5.1	Recommended PCB Footprint	29
5.2	Soldering information	30
5.3	Device handling instructions	30
5.4	Device operation instructions	31
5.5	Tape & Reel specification	32
6	Application Information	33
6.1	Transmission Range.....	33
7	REGULATORY INFORMATION.....	34
7.1	CE (RED) for European Union.....	34
7.2	FCC (United States) Certificate.....	35
7.2.1	FCC (United States) regulatory statement.....	36
7.2.2	FCC (United States) labeling requirements	36
7.2.3	FCC (United States) RF exposure statement.....	36
7.3	ISED (Industry Canada) Technical Acceptance Certificate	37
7.3.1	ISED (Industry Canada) regulatory statement	38
7.3.2	ISED (Industry Canada) RF exposure statement	38

TCM 515B – 2.4 GHZ BLUETOOTH LOW ENERGY (BLE) Transceiver

1 General Description

1.1 Basic functionality

TCM 515B provides radio transceiver functionality (telegram transmission and reception) according to the Bluetooth Low Energy standard in the 2.4 GHz radio band. TCM 515B receives and transmits radio telegrams based on a whip or PCB antenna connected via the host PCB.

TCM 515B is primarily intended for use within energy harvesting wireless sensors where it will provide the required radio functionality. To meet this requirement, TCM 515B provides a radio application programming interface (API) for transmission and reception of 2.4 GHz BLE radio telegrams. This radio API can be used by sensor applications running on TCM 515B to transmit and receive radio telegrams.

Additionally, TCM 515B provides an ESP3 interface to an external host which can be used to transmit and receive data tele-grams.

TCM 515B provides an I2C interface which can be used to connect external sensors.

TCM 515B is implemented as 31 pin reflow-solderable module in an optimized form factor to enable size constrained applications. The module design is mechanically compatible with the other members of the TCM 515 radio transceiver family to enable reuse.

Figure 1 below shows TCM 515B.



Figure 1 – TCM 515B outline

TCM 515B – 2.4 GHZ BLUETOOTH LOW ENERGY (BLE) Transceiver

1.2 Technical data

Antenna	External 50 Ohm or whip antenna (connected at host board)
Supported Radio Frequency Range	2402 ... 2480 MHz
Default Radio Channels	Advertising on Channel 37, 38 and 39
Data Rate	1 Mbit / s (default), 2 Mbit / s
Receiver Sensitivity (at 25°C) ⁽¹⁾	Minimum: -92dBm / Typical: -95 dBm
Transmit Power (at 25°C)	Adjustable up to +4 dBm
Power Supply	3.3 V +- 10%
Serial Host Interface	UART according to ESP3 Standard with Turbo Mode Option
Current Consumption (typ, at 25°C)	15 mA
Module Dimensions	19.0 x 14.7 x 3.0 mm (each dimension +-0.3 mm)

Note (1): Receiver sensitivity is based on the combination of 3 subtelegrams

1.3 Physical dimensions

Module Dimensions	19.0 x 14.7 x 3.0 mm (each dimension +-0.3 mm)
Module Weight	1 g

1.4 Environmental conditions

Operating Temperature	-25°C ... 85°C
Storage Temperature	-25°C ... 85°C
Humidity	0% to 95% r.h. (non-condensing)

1.5 Packaging information

Packaging Unit	250 units
Packaging Method	Tape and reel

1.6 Ordering information

Type	Ordering Code	Frequency
TCM 515B	S3223-K515	2.4 GHz (BLE)

TCM 515B – 2.4 GHZ BLUETOOTH LOW ENERGY (BLE) Transceiver

2 Functional Information

2.1 TCM 515B Device Interface

TCM 515B implements a 31 pin reflow-solderable interface. Solder mask data is available on request from EnOcean. The pin assignment (as seen from the top of the device) is shown in Figure 2 below.

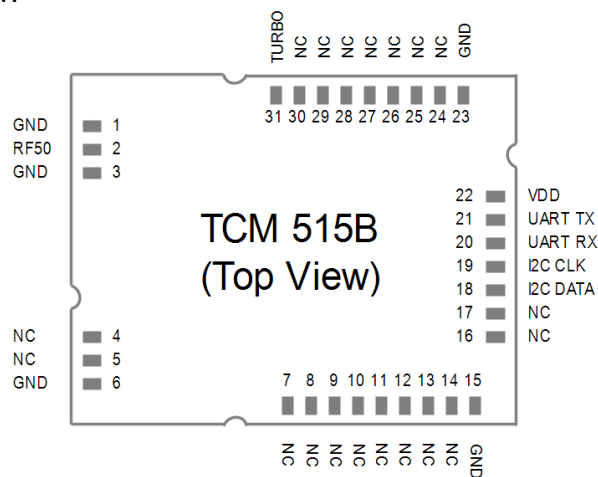

Figure 2 – TCM 515B device interface

Table 1 below summarizes the signal assignment.

PIN	NAME	PIN	NAME	PIN	NAME
1	GND	12	Digital IO	23	GND
2	ANTENNA (50 Ohms)	13	Digital IO	24	Debug
3	GND	14	Digital IO	25	Debug
4	Digital IO	15	GND	26	Digital IO
5	Digital IO	16	Analog / Digital IO	27	Digital IO
6	GND	17	Analog / Digital IO	28	Digital IO
7	Analog / Digital IO	18	I2C Data	29	Digital IO
8	Analog / Digital IO	19	I2C CLK	30	Digital IO
9	Analog / Digital IO / 32 kHz OSC	20	UART RX (Input)	31	TURBO
10	Analog / Digital IO / 32 kHz OSC	21	UART TX (Output)		
11	Analog / Digital IO	22	VDD		

Table 1 - TCM 515B device interface pin assignment

TCM 515B – 2.4 GHZ BLUETOOTH LOW ENERGY (BLE) Transceiver

2.1.1 Signal Description

TCM 515B is supplied by the VDD and GND Pins. The required supply voltage is 3.3V with a tolerance of no more than +/-10%.

TCM 515B receives and transmits data based on a 50Ω whip antenna connected to its ANTENNA input (Pin 2).

TCM 515B communicates with the external host using the standard ESP3 serial (UART) interface based on the signals UART_TX (Pin 21, direction from TCM 515B to external host) and UART_RX (Pin 20, direction from external host to TCM 51Z).

The default interface speed of the ESP3 interface is 57600 bit per second (the exact speed is 57347 Bit per second, a deviation of -0.04%).

It is possible to select faster communication speeds of 115200, 230400 and 460800 bit per second during operation using the ESP3 CO_SET_BAUDRATE command.

Additionally it is possible to change the default ESP3 interface speed at power up from 57.600 Bit per second to 460.800 Bit per second by connecting the TURBO input (Pin 31) to Ground. Subsequent modification of the interface speed during operation using the CO_SET_BAUDRATE command is always possible irrespective of the state of the TURBO input pin.

TCM 515B provides one or two I2C interfaces as primary means to connect external sensors. Additionally, it provides digital and analog inputs and outputs as well as the option for an SPI interface.

2.2 High-level operation principle

In receive mode, TCM 515B forwards the content of received BLE radio telegrams (which pass frame check sum validation) unmodified to the sensor application SW or an external host via the ESP3 interface. The sensor application can use the data of received telegrams for instance to adjust parameters such as update intervals.

In transmit mode, TCM 515B receives from the application SW or an external host the pre-computed message payload. TCM 515B then calculates the frame check sum and appends it to the message. The full frame (including the Preamble and Start of Frame fields) will then be transmitted as BLE radio telegram (TX mode).

The sensor application uses an internal or external timer to periodically wake-up and check the status of the connected sensors. Based on this status information, it will decide if transmission of a telegram is necessary and if so forward it to the radio routine by means of its API.

TCM 515B – 2.4 GHZ BLUETOOTH LOW ENERGY (BLE) Transceiver

2.3 Radio functionality

TCM 515B transmits and receives advertising telegrams within the 2.4 GHz radio frequency band (2402MHz ... 2480MHz) using the BLE advertising frame format.

By default, TCM 515B will use the three BLE advertising channels (BLE Channel 37, 38 and 39) defined for transmission and reception. The transmission of a radio telegram on these three advertising channels is called an Advertising Event.

Use of different radio channels within the frequency band from 2402 MHz to 2480 MHz is possible and can be configured by the application software or the external host (via ESP3 interface).

Table 2 below summarizes radio channels supported by TCM 515B.

Radio Channel	Frequency	Channel Type
BLE Radio Channels		
37	2402 MHz	BLE Advertising Channel
0	2404 MHz	BLE Data Channel
1	2406 MHz	BLE Data Channel
...		
10	2424 MHz	BLE Data Channel
38	2426 MHz	BLE Advertising Channel
11	2428 MHz	BLE Data Channel
12	2430 MHz	BLE Data Channel
...		
36	2478 MHz	BLE Data Channel
39	2480 MHz	BLE Advertising Channel
Custom Radio Channels		
40	2403 MHz	Custom Radio Channel
41	2405 MHz	Custom Radio Channel
...		
77	2477 MHz	Custom Radio Channel
78	2479 MHz	Custom Radio Channel

Table 2 – TCM 515B supported radio channels

TCM 515B – 2.4 GHZ BLUETOOTH LOW ENERGY (BLE) Transceiver

2.4 Radio transmission sequence

TCM 515B transmits telegrams in its standard configuration by using so-called Advertising Events.

An advertising event is defined as the transmission of the same radio telegram on all selected radio channels (by default this would be on BLE Channel 37, 38 and 39) one after another with minimum delay in between.

For reliability reasons, TCM 515B will send three redundant advertising events for each transmission. The resulting transmission sequence is shown in Figure 3 below.

CH37	CH38	CH39	Pause (20 ms)	CH37	CH38	CH39	Pause (20 ms)	CH37	CH38	CH39
------	------	------	------------------	------	------	------	------------------	------	------	------

Figure 3 – Default radio transmission sequence

2.5 Radio reception sequence

TCM 515B receives radio telegrams in its standard configuration by monitoring the Advertising Channels (Channel 37, 38 and 39). Alternative channels can be selected via the radio API or the ESP3 interface.

TCM 515B will continuously scan these channels one after the other for valid data telegrams. The time spent on each channel is configurable.

2.6 User-defined radio channels

In certain situations, it might be desirable to transmit and receive radio telegrams on channels other than the three advertising channels.

TCM 515B therefore allows to select the radio channels to be used for the transmission and reception. The selection of the radio channels is done by the application SW using the radio API or the external host using the ESP3 interface.

2.7 Data rate

The default data rate of TCM 515B is 1 Mbit/s. It is possible to change to an alternative data rate of 2 Mbit / s by the application SW using the radio API or the external host using the ESP3 interface.

TCM 515B – 2.4 GHZ BLUETOOTH LOW ENERGY (BLE) Transceiver

3 Telegram format

TCM 515B transmits and receives radio telegrams in the 2.4 GHz band according to BLE frame structure. For detailed information about the BLE standard, please refer to the applicable specifications.

Figure 4 below summarizes the BLE frame structure.

Preamble 0xAA	Access Address 0x8E89BED6	Header (2 Byte)	Source Address (6 Byte)	Payload (0 ... 31 Byte)	Check Sum (3 Byte)
------------------	------------------------------	--------------------	----------------------------	----------------------------	-----------------------

Figure 4 – BLE frame structure

The content of these fields is described in more detail below.

3.1 Preamble

The BLE Preamble is 1 byte long and identifies the start of the BLE frame. The value of the BLE Preamble is always set to 0xAA.

3.2 Access Address

The 4 byte BLE Access Address identifies the radio telegram type. For advertising frames, the value of the Access Address is always set to 0x8E89BED6.

3.3 Header

The BLE Header identifies certain radio telegram parameters. Figure 5 below shows the structure of the BLE header.

TYPE (4 Bit)	UNUSED (2 Bit)	TX ADDR (1 Bit)	RX ADDR (1 Bit)	LENGTH (6 Bit)	UNUSED (2 Bit)
0010: TX-only Advertising (ADV_NONCONN_IND)	00	1: Random	0: Not used	Length of Address + Payload	00

Figure 5 – BLE header structure

TCM 515B – 2.4 GHZ BLUETOOTH LOW ENERGY (BLE) Transceiver

3.4 Source address

The 6 byte BLE Source Address (MAC address) uniquely identifies each TCM 515B product.

TCM 515B supports two source address modes:

- **Static Source Address mode (default)**
In this mode, the source address is constant (but its lower 32 bit can be configured via radio API)
- **Private Resolvable Address mode (NFC configurable)**
In this mode, the source address changes for each transmission

TCM 515B uses by default the Static Source Address mode. Private Resolvable Address mode can be selected via the radio API. These two address modes are described in the following chapters.

3.4.1 Static source address mode

By default, TCM 515B uses static source addresses meaning that the source address is constant during normal operation. The structure of TCM 515B static addresses is as follows:

- The upper 2 bytes of the source address are used to identify the device type and set to 0xE500 to designate EnOcean STM 500 multi-sensor type. These two bytes cannot be changed.
- The lower 4 bytes are uniquely assigned to each device.

Figure 6 below illustrates the static address structure used by TCM 515B.



Figure 6 – BLE static source address structure

TCM 515B – 2.4 GHZ BLUETOOTH LOW ENERGY (BLE) Transceiver

3.4.2 Private resolvable source address mode

For some applications it is desirable to modify (rotate) the source address used by TCM 515B in order to prevent tracking of its radio transmissions. At the same time, each TCM 515B device must remain uniquely identifiable by the receiver.

To achieve these goals, TCM 515B can be configured via radio API to use random resolvable private addresses.

Using random resolvable private addresses requires that both TCM 515B and the receiver both know a common key – the so-called Identity Resolution Key (IRK). TCM 515B uses its device-unique random key as identity resolution key.

For resolvable private addresses, the 48 bit address field is split into two sub-fields:

- prand
This field contains a random number which always starts (two most significant bits) with 0b10. The prand value is changed for each telegram that is transmitted. Individual advertising events used to transmit one telegram use the same prand value.
- hash
This field contains a verification value (hash) generated from prand using the IRK

The structure of a random resolvable private address is shown in Figure 7 below.

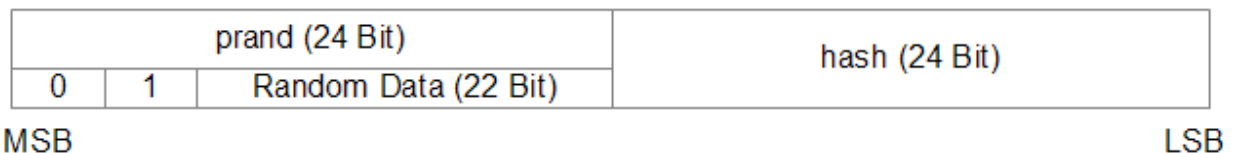

Figure 7 – BLE private resolvable source address structure

The prand value is encrypted using the IRK. The lowest 24 bit of the result (encrypted value) are then used as hash.

The concatenation of 24 bit prand and 24 bit hash will be transmitted as 48 bit private resolvable source address.

TCM 515B – 2.4 GHZ BLUETOOTH LOW ENERGY (BLE) Transceiver

The receiving device maintains a list of IRK for all transmitters that have been commissioned to work with it.

Whenever the receiving device receives a radio telegram with private resolvable source address (identified by the most significant bits being set to 0b10), it will itself generate a 24 bit hash from the 24 bit prand sequentially using the IRK of each device that it has been learned into it.

If an IRK matches (i.e. when prand is encoded with this specific IRK then the result matches hash), then the receiver has established the identity of the transmitter.

So conceptually the IRK takes the role of the device source address while prand and hash provide a mechanism to select the correct IRK among a set of IRK.

This mechanism is illustrated in Figure 8 below.

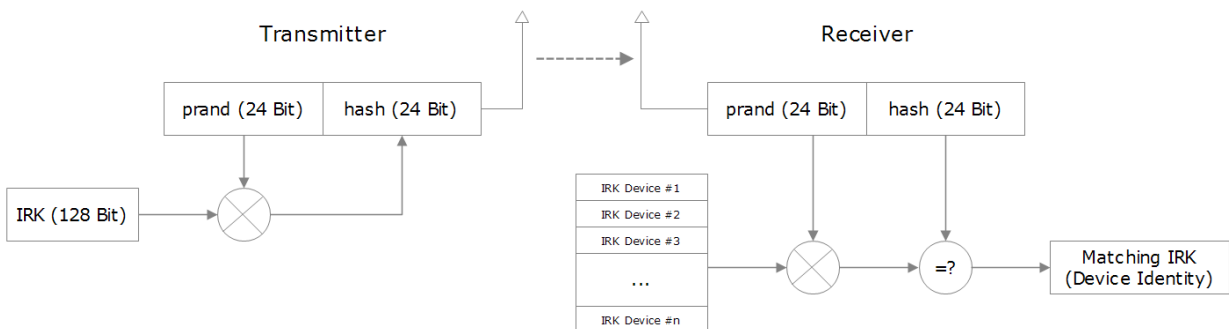

Figure 8 – Resolving private source addresses

3.5 Check Sum

The 3 byte BLE Check Sum is used to verify data integrity of received BLE radio telegrams. It is calculated as CRC (cyclic redundancy check) of the BLE Header, Source Address and Payload fields.

TCM 515B will discard received radio telegrams that do not pass the CRC check.

TCM 515B – 2.4 GHZ BLUETOOTH LOW ENERGY (BLE) Transceiver

3.6 Payload

The payload of data telegrams is up to 31 bytes long (depending on the size of the sensor data) and consists of the following fields:

- Length (1 byte)
The Length field specifies the combined length of the following fields and depends on the size of the Sensor Status field. The minimum length is 13 byte and the maximum length is 31 byte
- Type (1 byte)
The Type field identifies the data type used for this telegram. For TCM 515B data telegrams, this field is always set to 0xFF to designate manufacturer-specific data field
- Manufacturer ID (2 byte)
The Manufacturer ID field is used to identify the manufacturer of BLE devices based on assigned numbers. EnOcean has been assigned 0x03DA as manufacturer ID code.
- Sequence Counter (4 byte)
The Sequence Counter is a continuously incrementing counter used for security processing. It is initialized to 0 at the time of production and incremented for each telegram (data telegram or commissioning telegram) sent.
- Sensor Data (variable size)
The Sensor Data field reports the measured values of the sensors. The encoding of this field is described in chapter 3.7.
- Security Signature (4 byte)
The Security Signature is used to authenticate TCM 515B radio telegrams as described in chapter 0

Figure 9 below illustrates the telegram payload structure.

1 Byte	0xFF	Manufacturer ID 0x03DA	Sequence Counter (4 Byte)	Sensor Status (variable)	Security Signature (4 Byte)
LEN TYPE					

Figure 9 – Telegram payload structure

TCM 515B – 2.4 GHZ BLUETOOTH LOW ENERGY (BLE) Transceiver

3.7 Sensor status encoding

The Sensor Status field within the Payload data identifies the status of the connected sensors. The Sensor Status field is composed of sub-fields (one per sensor attribute).

Each sub-field consists of two items:

- **Sensor Data Descriptor**
The descriptor identifies the type of the attribute and the size of the following data field
- **Sensor Data**
The sensor data encodes the attribute data

Figure 10 below shows the structure of the sensor status field.

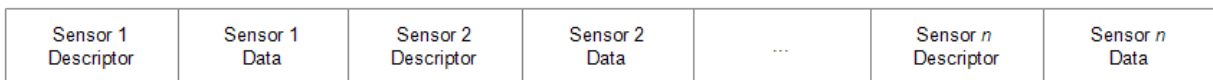

Figure 10 – Sensor Status field structure

3.7.1 Sensor Data Descriptor

The Sensor Data Descriptor describes type and size of the following sensor data field. It explicitly specifies the size to ensure forward compatibility, i.e. to enable future receivers to parse sensor telegrams containing unknown data types.

The Sensor Data Descriptor structure is shown in Figure 11 below.

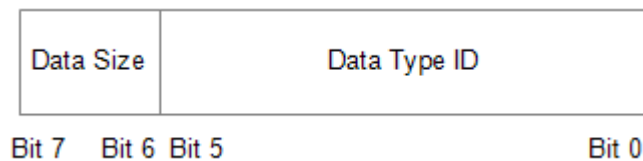

Figure 11 – Sensor Data Descriptor field structure

TCM 515B – 2.4 GHZ BLUETOOTH LOW ENERGY (BLE) Transceiver

3.7.2 Sensor Status

The Sensor Status field encodes the current status (last reported value) of a sensor.

As described above, the type of the sensor data is identified by the Data Type ID field and its size is identified by the Data Size field of the preceding Sensor Data Descriptor.

Table 3 below shows the sensor status encoding used by TCM 515B.

ID	Type	Size [bytes]	signed	Minimum	Maximum	Unit	Encoding (Input = x)	Measurement too low	Measurement Invalid
0x00	Temperature	2	yes	-327.67	327.66	°C	100 * x	0x8000	0x7FFF
0x01	Voltage	2	yes	-16 383.5	16 383.5	mV	2 * x	0x8000	0x7FFF
0x02	Battery level	1	no	0	126.5	%	2 * x	0xFF	0xFE
0x03	Current	2	yes	-32 767	32 766	µA	x	0x8000	0x7FFF
0x04	Illuminance (wide angle)	2	no	0	65 533	lx	x	0xFFFF	0xFFFE
0x05	Illuminance (Narrow angle)	2	no	0	65 533	lx	x	0xFFFF	0xFFFE
0x06	Relative humidity	1	no	0	126.5	%	2 * x	0xFF	0xFE
0x07	Pressure	2	yes	-32 767	32 766	hPa	x	0x8000	0x7FFF
0x08	Distance	2	no	0	~1023.95	cm	64 * x	0xFFFF	0xFFFE
0x09	Gas concentration	2	no	0	32 766.5	ppm	2 * x	0xFFFF	0xFFFE
0x0A	Acceleration	2	yes	~-16	~16	G	2048 * x	0x8000	0x7FFF
Enumerations									
ID	Type	Size [bytes]	Enumerated values						
0x20	Occupancy	1	0x00: Generic Error	0x01: Not occupied	0x02: Occupied	0x03: Standby			
0x21	Smoke	1	0x00: Generic error	0x01: No smoke	0x02: Smoke (ion chamber)	0x03: Smoke (opt. chamber)	0x04: Smoke (both chambers)		
0x22	Mechanical handle	1	0x00: Generic error	0x01: Up	0x02: Right	0x03: Down	0x04: Left		
				0x05: Up to right	0x06: Right to down	0x07: Down to left	0x08: Left to up		
				0x09: Up to left	0x0A: Left to down	0x0B: Down to right	0x0C: Right to up		
0x23	Open/closed	1	0x00: Generic error	0x01: Closed	0x02: Open				
System Messages									
0x3B	Device descriptor	Variable	All values: Application specific, Size defined by descriptor						
0x3C	Error report	1	0x00: No error	Other values: Application specific					
0x3D	User data	Variable	All values: Application specific, Size defined by descriptor						
0x3E	Commissioning	26	Commissioning telegram: 4 byte Sequence Counter + 6 byte Source Address + 16 byte Private Key						

Table 3 – Sensor status encoding

TCM 515B – 2.4 GHZ BLUETOOTH LOW ENERGY (BLE) Transceiver

3.8 TCM 515B telegram authentication

TCM 515B implements telegram authentication to ensure that only telegrams from senders using a previously exchanged security key will be accepted. Authentication relies on a 32 bit telegram signature which is calculated as shown in Figure 12 below and exchanged as part of the radio telegram.

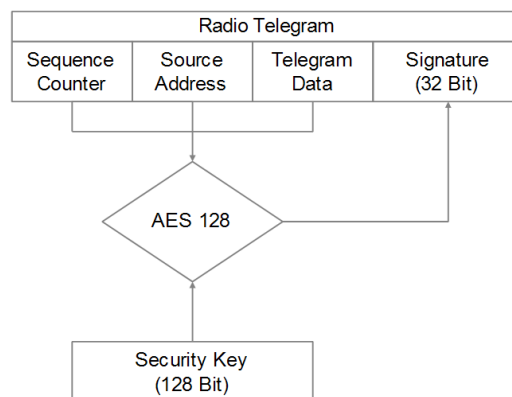

Figure 12 – Telegram authentication flow

Sequence counter, source address and the remaining telegram data together form the input data for the signature algorithm. This algorithm uses AES128 encryption based on the device-unique random security key to generate a 32 bit signature which will be transmitted as part of the radio telegram.

The signature is therefore dependent both on the current value of the sequence counter, the device source address and the telegram payload. Changing any of these three parameters will therefore result in a different signature.

The receiver performs the same signature calculation based on sequence counter, source address and the remaining telegram data of the received telegram using the security key it received from TCM 515B during commissioning.

The receiver then compares the signature reported as part of the telegram with the signature it has calculated. If these two signatures match then the following statements are true:

- Sender (TCM 515B) and receiver use the same security key
- The message content (address, sequence counter, data) has not been modified

At this point, the receiver has validated that the message originates from a trusted sender (as identified by its security key) and that its content is valid.

In order to avoid message replay (capture and retransmission of a valid message), it is required that the receiver tracks the value of the sequence counter used by TCM 515B and only accepts messages with higher sequence counter values (i.e. not accepts equal or lower sequence counter values for subsequent telegrams).

TCM 515B – 2.4 GHZ BLUETOOTH LOW ENERGY (BLE) Transceiver

3.9 ESP3 Interface

TCM 515B provides a bi-directional UART interface for communicating with the external host. The default baud rate of this interface is 57600 bps. If the TURBO pin is set to active low then the baud rate is increased to 460.800 bps.

3.9.1 ESP3 Data Format

TCM 515B communicate with external hosts using EnOcean Serial Protocol version 3 (ESP3) with EnOcean 2.4 GHz extensions.

Please consult the detailed ESP3 specification at <https://www.enocean.com/esp>.

TCM 515B – 2.4 GHZ BLUETOOTH LOW ENERGY (BLE) Transceiver

4 Antenna Options

This chapter outlines options for antenna that can be used with TCM 515B. Note that this chapter is for guidance purposes only, please consult with an authorized certification body for specific information.

4.1 General antenna requirements for TCM 515B

Antenna used TCM 515B shall always meet the requirements listed in the table below.

Frequency band	2.4 GHz ISM	Antenna must be suited for this band
Antenna type	Passive	Mandatory for radio approval
Impedance	~50 Ohm	Mandatory for radio approval
Maximum gain	≤ 5 dBi	Mandatory for radio approval

Table 4 – General Antenna requirements

4.2 European Union

TCM 515B can within the European Union be used with all antennas described in subsequent chapters. See chapter 6 for additional important remarks regarding RED certification.

TCM 515B – 2.4 GHZ BLUETOOTH LOW ENERGY (BLE) Transceiver

4.3 US / Canada

The TCM 515B has been tested and certified according to FCC regulation with a number of different antennas as described below.

4.3.1 Whip Antenna

TCM 515B modules have been certified for use with a whip antenna as specified below.

4.3.1.1 Whip Antenna Parameters

Figure 13 below shows the mandatory parameters of the whip antenna.

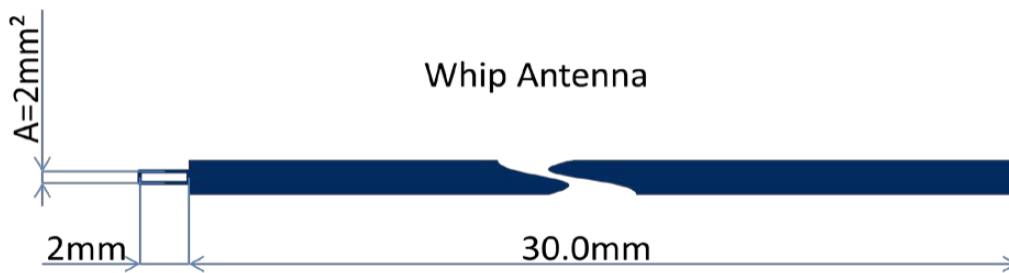

Figure 13 – Whip antenna with parameters for 2.4 GHz

The whip antenna has to meet the following parameters:

- Antenna length (L): 30 mm wire, connect to RF_WHIP
- Minimum GND plane: 15 mm x 15 mm
- Minimum distance space: 10 mm

TCM 515B – 2.4 GHZ BLUETOOTH LOW ENERGY (BLE) Transceiver

4.3.1.2 Whip Antenna Reference Layout

The reference layout for this antenna is shown in Figure 14 below. The area within the green dotted rectangle and the minimum ground plane has to be implemented exactly as shown in order to use EnOcean modular approval for US / Canada.

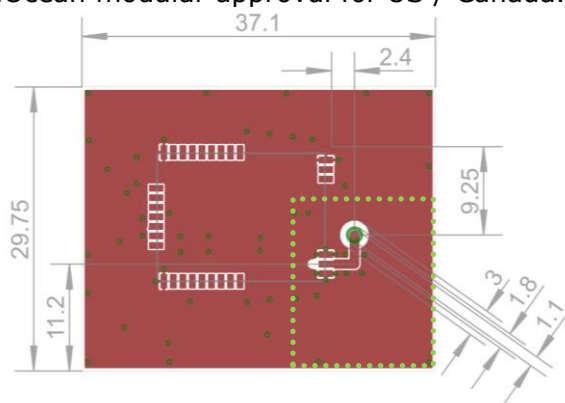

Figure 14 – Whip antenna reference layout

4.3.1.1 Whip Antenna Transmission Line

Additionally, the transmission line between TCM 515B and the whip antenna has to be implemented as specified in Figure 15 below in order to use EnOcean modular approval for US / Canada.

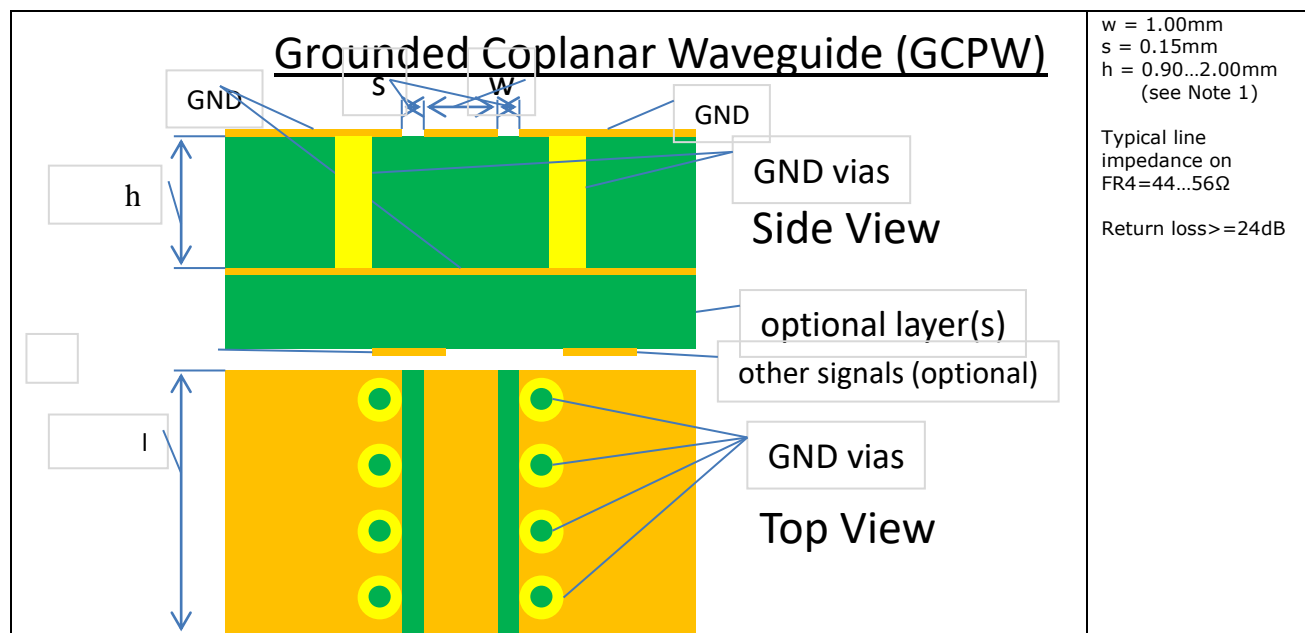

Figure 15 – Transmission line specification

Note (1): Coplanar waveguide modes are dominant in this configuration. Thus thickness of substrate can be changed with the given limits.

TCM 515B – 2.4 GHZ BLUETOOTH LOW ENERGY (BLE) Transceiver

4.3.2 Meandered PCB Antenna

TCM 515B has been certified for use with a meandered PCB antenna provided that the following layout guidelines are met:

- Matching circuit values of the modular approval may not be changed, use matching circuit components as specified in Table 5
- Shape according to reference layout in Figure 16
- Minimum GND plane: 40 mm x 18 mm
- Connect GND planes using multiple via as shown in Figure 16
- Minimum distance space: 10 mm
- PCB Stack of the modular approval may not be changed, use PCB stack as specified in Figure 17

4.3.2.1 Meandered PCB Antenna Layout

Figure 16 below shows the dimensions of the meandered PCB antenna, the matching circuit and the area important for US / Canada modular approval (marked in green).

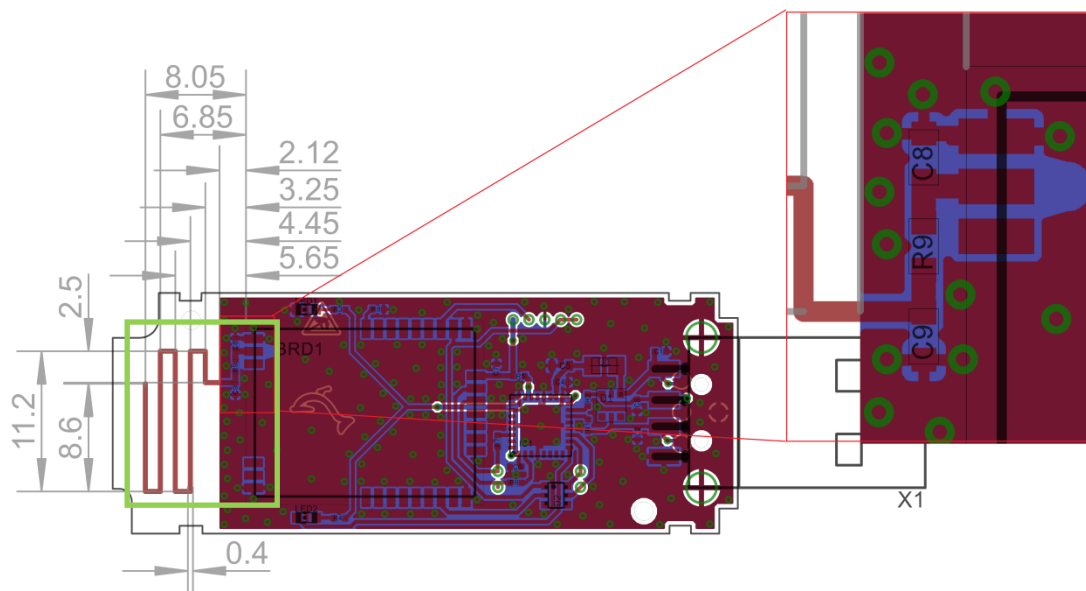

Figure 16 – Reference layout for meandered PCB antenna

TCM 515B – 2.4 GHZ BLUETOOTH LOW ENERGY (BLE) Transceiver

4.3.2.2 Meandered PCB Antenna PCB Stack

Figure 17 below shows the required PCB stack for the meandered PCB antenna.

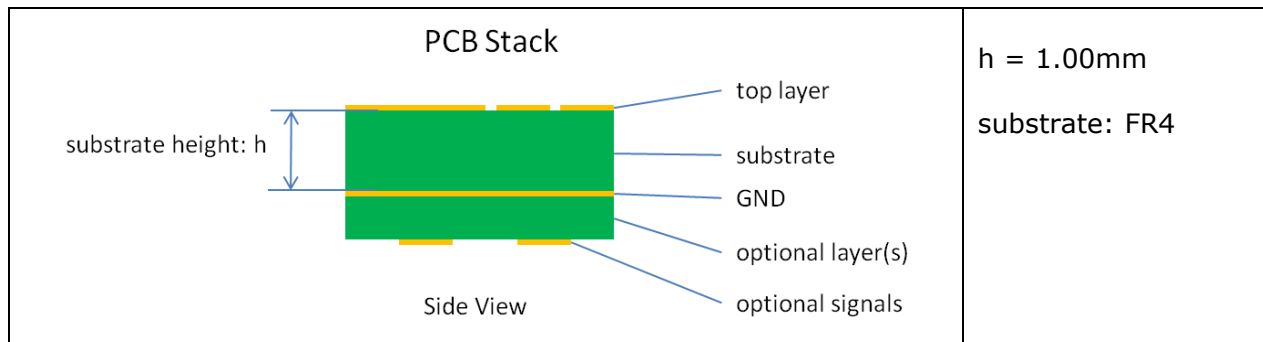

Figure 17 – PCB stack specification for meandered PCB antenna

4.3.2.3 Meandered PCB Antenna Matching

Table 5 below lists the parameters of the matching circuit components using a FR4 substrate with 1.0 mm height. It is mandatory to not change the designator values and substrate height for compliance with US / Canada modular approval usage.

Designator	Value	Notes
C8	1.0pF	Use Murata GRM1555 series or similar
R9	6.8nH	Use Würth WE-KI series, Murata LQW series or similar
C9	---	Not assembled

Table 5 – Parameters of the matching circuit for 1.0 mm substrate height

TCM 515B – 2.4 GHZ BLUETOOTH LOW ENERGY (BLE) Transceiver

4.3.3 Dipole Antennae

The TCM 515B has been certified for use with the dipole antenna model S151AH-2450S from Nearson or other antennas with similar parameters provided that:

- The RF connector is a non-standard connector such as a RP-SMA-Female from Johnson/Cinch Connectivity Solutions (142-4701-801)

Figure 18 below shows dipole antenna model S151AH-2450S from Nearson that was used for certification tests.

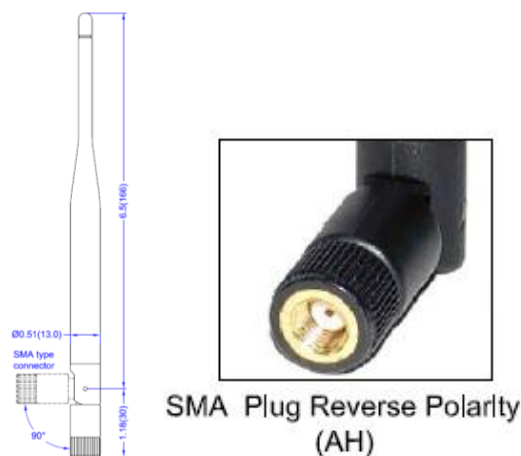

Figure 18 – Dipole antenna S151AH-2450S

Table 6 at the end of this section lists dipole antennas that can be used optional instead of S151AH-2450S antenna stated previously as they are of the same kind with less or equal gain.

The following layout guidelines have to be met for the use of a dipole antenna:

- The bottom GND plane is implemented below the RF transmission line section of the circuit to form a grounded coplanar waveguide as shown in Figure 21
- The ground planes have to be connected using multiple via along RF transmission line as shown in Figure 19 and Figure 21

TCM 515B – 2.4 GHZ BLUETOOTH LOW ENERGY (BLE) Transceiver

4.3.3.1 Dipole PCB Antenna Layout

Figure 19 below shows the layout used for compliance tests. The section of the layout located within the green frame has to remain unchanged for US / Canada modular approval usage.

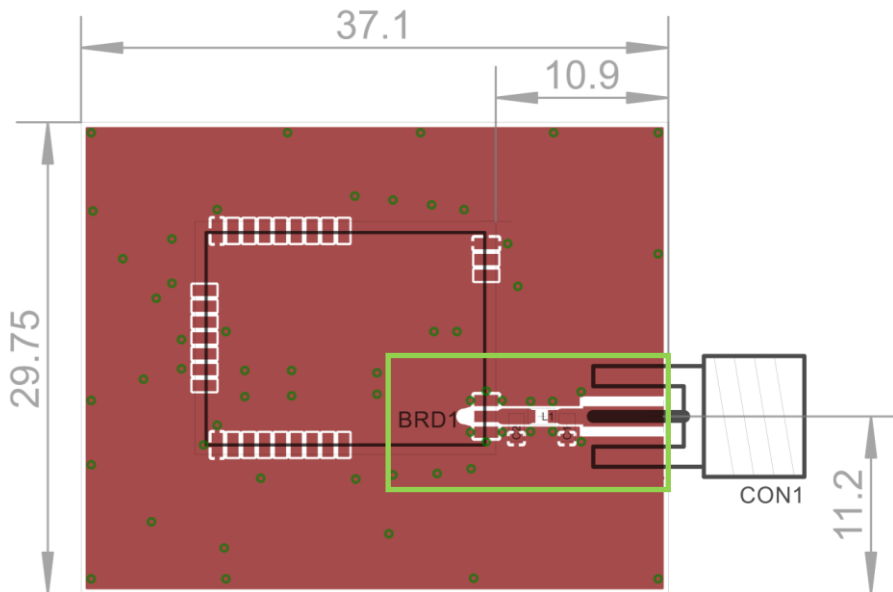

Figure 19 – Reference layout for dipole antenna

4.3.3.2 Dipole PCB Antenna Connector

Figure 20 below displays the RP-SMA-Female (142-4701-801) from Chinch Connectivity Solutions as an example for a non-standard RF connector required for US / Canada modular approval usage.

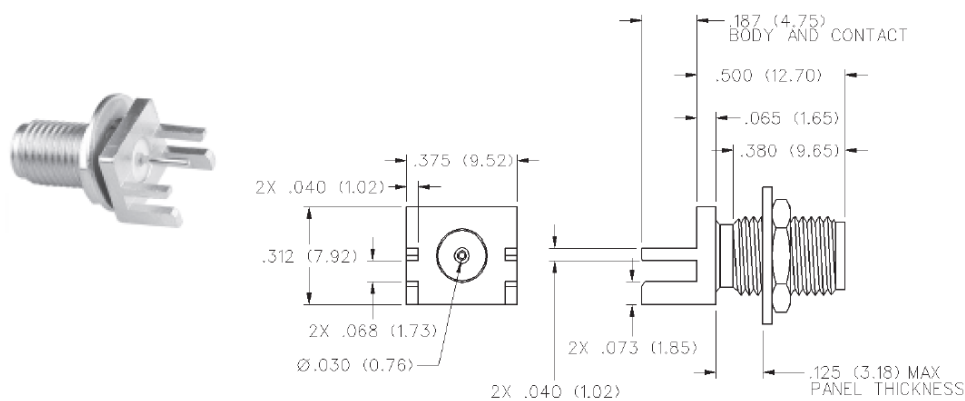

Figure 20 – RP-SMA-Female

TCM 515B – 2.4 GHZ BLUETOOTH LOW ENERGY (BLE) Transceiver

4.3.3.3 Dipole Antenna PCB Stack

The transmission line between TCM 515B and the dipole antenna has to be implemented as shown in Figure 21 below.

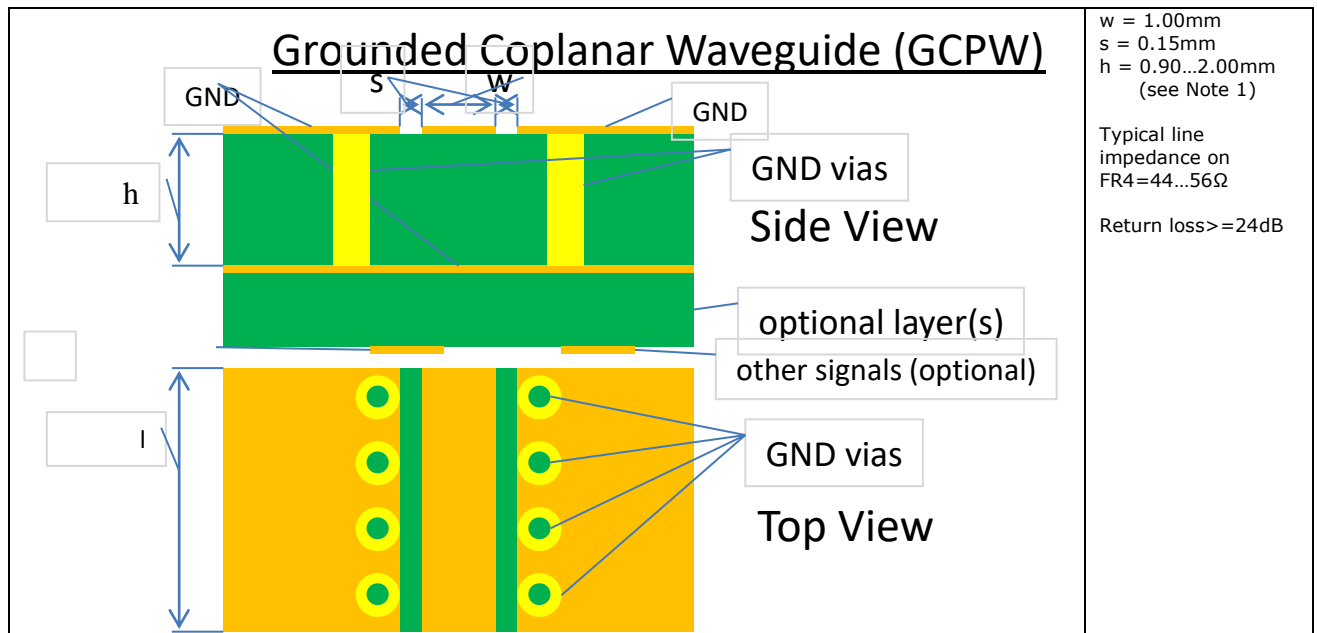

Figure 21 – Detailed description of RF transmission line

Note (1): Coplanar waveguide modes are dominant in this configuration. Thus thickness of substrate can be changed with the given limits.

TCM 515B – 2.4 GHZ BLUETOOTH LOW ENERGY (BLE) Transceiver

4.3.3.4 Dipole Antenna Examples

Table 6 gives a list of examples of dipole antennas that could be used with TCM 5151B under US / Canada modular approval.

Manufacturer	Manufacturer Part Number	Gain	Antenna Type
Nearson Inc. ¹	S151AH-2450S	5dBi	Whip (Dipole), Tilt
Nearson Inc.	S131AH-2450S	5dBi	Whip (Dipole), Tilt
Nearson Inc.	S181AH-2450S	2dBi	Whip (Dipole), Tilt
ATOP Technologies	ANT-WS-AB-RM-05-200	5dBi	Whip (Dipole), Straight
ATOP Technologies	ANT-WS-AB-RM-05-180	5dBi	Whip (Dipole), Straight
Digi International	A24-HASM-525	2.1dBi	Whip (Dipole), Tilt
Digi International	A24-HASM-450	2.1dBi	Whip (Dipole), Tilt
Digi International	DG-ANT-20DP-BG	2dBi	Whip (Dipole), Tilt
Digi International	DC-ANT-24DP	1.8dBi	Whip (Dipole), Tilt
Digi International	DC-ANT-24DT	1.8dBi	Whip (Dipole), Straight
Honeywell	WAN01RSP	2.2dBi	Whip (Dipole), Straight
Honeywell	WAN02RSP	2.2dBi	Whip (Dipole), Tilt
Laird Technologies IAS	S2403BH36RSM	3dBi	Whip (Dipole), Straight
Laird Technologies IAS	EXR2400RSM	3dBi	Whip (Dipole), Tilt
Laird Technologies IAS	MAF94046	1.3dBi	Whip (Dipole), Tilt
Laird Technologies IAS	MAF94028	1.3dBi	Whip (Dipole), Tilt
Laird Technologies IAS	MAF94112	1.5dBi	Whip (Dipole), Tilt
Linx Technologies Inc.	ANT-2.4-CW-HW	3.2dBi	Whip (Dipole), Straight
Linx Technologies Inc.	ANT-2.4-CW-RCT-RP	2.2dBi	Whip (Dipole), Tilt
Linx Technologies Inc.	ANT-2.4-CW-HWR-RPS	3.2dBi	Whip (Dipole), Tilt
Linx Technologies Inc.	ANT-2.4-CW-CT-RPS	2.8dBi	Whip (Dipole), Straight
LSR	001-0010	2dBi	Whip (Dipole), Tilt
LSR	001-0001	2dBi	Whip (Dipole), Tilt
Microchip Technology	RN-SMA4-RP	2.2dBi	Whip (Dipole), Tilt
Proant AB	333	3dBi	Whip (Dipole), Tilt
Proant AB	348	3dBi	Whip (Dipole), Straight
Pulse Electronics	W1037	3.2dBi	Whip (Dipole), Tilt
Pulse Electronics	W1027	3.2dBi	Whip (Dipole), Tilt
Pulse Electronics	W1030	2dBi	Whip (Dipole), Tilt
Pulse Electronics	W5010	1.5dBi	Whip (Dipole), Straight
Pulse Electronics	W5001	1.5dBi	Whip (Dipole), Right Angle
Red Lion Controls	ANT-GW11A153	2.3dBi	Whip (Dipole), Tilt
Siretta Ltd	DELTA6B/X/SMAM/RP/S/11	5dBi	Whip (Dipole), Tilt
Siretta Ltd	DELTA10A/X/SMAM/RP/S/17	3dBi	Whip (Dipole), Straight
Taoglas Limited	GW.11.A153	2.3dBi	Whip (Dipole), Tilt
Taoglas Limited	GW.26.0151	1.8dBi	Whip (Dipole), Straight
Walsin Technology	RFDPA151300SBAB8G1	3dBi	Whip (Dipole), Tilt
Walsin Technology	RFDPA171300SBAB8G1	3dBi	Whip (Dipole), Tilt
Walsin Technology	RFDPA870900SBAB8G1	2dBi	Whip (Dipole), Tilt

Table 6 – Dipole antenna options

¹ antenna tested for FCC and IC certification

TCM 515B – 2.4 GHZ BLUETOOTH LOW ENERGY (BLE) Transceiver

5 Device Integration

TCM 515B is designed for integration onto a host PCB. Detailed Gerber data of the device footprint is available from EnOcean upon request.

5.1 Recommended PCB Footprint

Figure 22 below shows the recommended PCB footprint for TCM 515B.

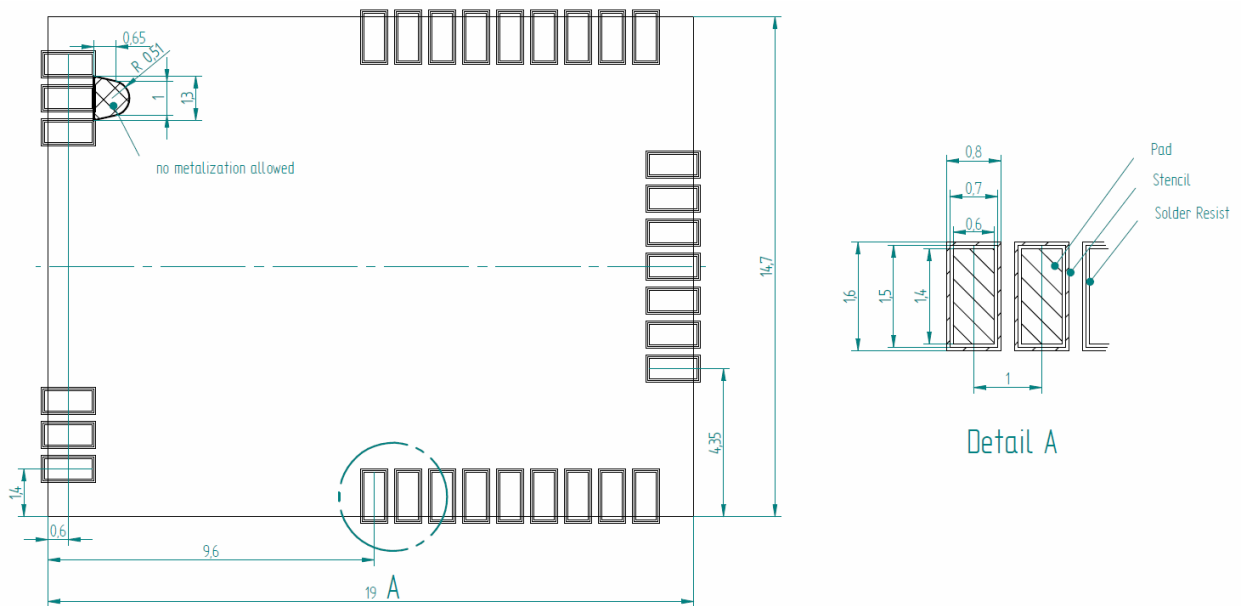

Figure 22 – Recommended PCB footprint

TCM 515B – 2.4 GHZ BLUETOOTH LOW ENERGY (BLE) Transceiver

5.2 Soldering information

TCM 515B has to be soldered according to IPC/JEDEC J-STD-020C standard as outlined in

Profile Feature	Pb-Free Assembly
Average Ramp-Up Rate (T _{Smax} to T _p)	3° C/second max.
Preheat	
- Temperature Min (T _{Smin})	150 °C
- Temperature Max (T _{Smax})	200 °C
- Time (t _{Smin} to t _{Smax})	60-180 seconds
Time maintained above:	
- Temperature (T _L)	217 °C
- Time (t _L)	60-150 seconds
Peak/Classification Temperature (T _p)	260 °C
Time within 5 °C of actual Peak Temperature (t _p)	20-40 seconds
Ramp-Down Rate	6 °C/second max.
Time 25 °C to Peak Temperature	8 minutes max.

Note 1: All temperatures refer to topside of the package, measured on the package body surface.

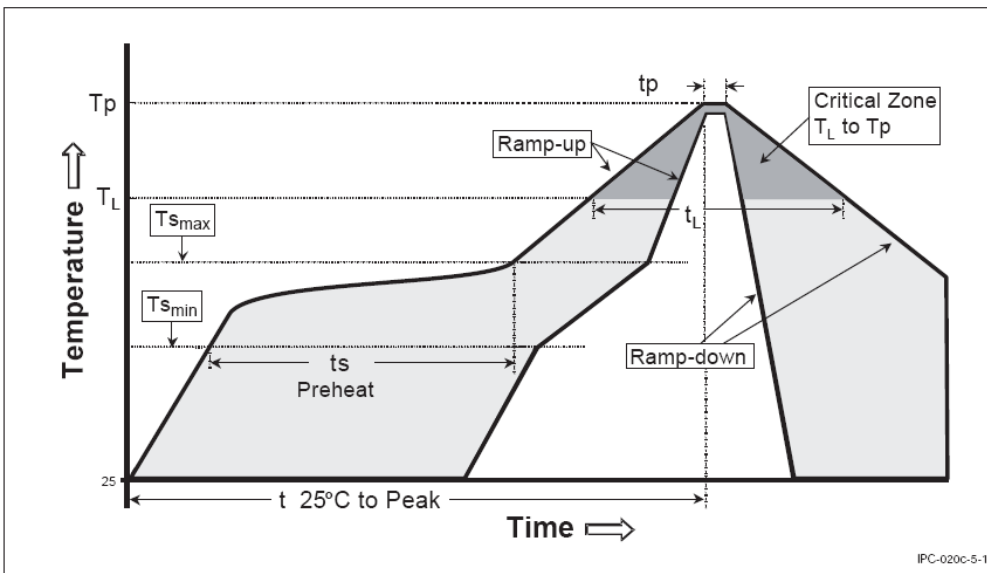

5.3 Device handling instructions

TCM 515B shall be handled according to Moisture Sensitivity Level MSL 3. TCM 515B may be soldered only once, since one time is already consumed at production of the module itself.

Once the dry pack bag is opened, the desired quantity of units should be removed and the bag resealed within two hours. If the bag is left open longer than 30 minutes the desiccant should be replaced with dry desiccant. If devices have exceeded the specified floor life time of 168 h, they may be baked according IPC/JEDEC J-STD-033B at max. 90 °C for less than 60 h.

Devices packaged in moisture-proof packaging should be stored in ambient conditions not exceeding temperatures of 40 °C or humidity levels of 90% r.H.

TCM 515B modules have to be soldered within 6 months after delivery!

TCM 515B – 2.4 GHZ BLUETOOTH LOW ENERGY (BLE) Transceiver

In general we recommend a no clean flux process. If washing is needed, then TCM 515B radio modules have a shield cover with small openings at the top of the edges.

It is very important to mount the modules in a top down position during the drying process as this will allow getting the aggregated washing fluid removed properly from within the shield cover area.

To prevent damage, modules have to be checked for any remaining fluid after the drying.

5.4 Device operation instructions

TCM 515B shall only be operated while assembled onto a PCB that is integrated into a suitable product housing.

TCM 515B shall only be supplied using “Limited Power Sources” compliant with EN 62368-1 clause 6.2.2.4 and a maximum output power of 15W (PS1).

TCM 515B – 2.4 GHZ BLUETOOTH LOW ENERGY (BLE) Transceiver

5.5 Tape & Reel specification

TCM 515B is delivered in Tape & Reel packaging with 250 units per reel. Figure 24 below illustrates the dimensions.

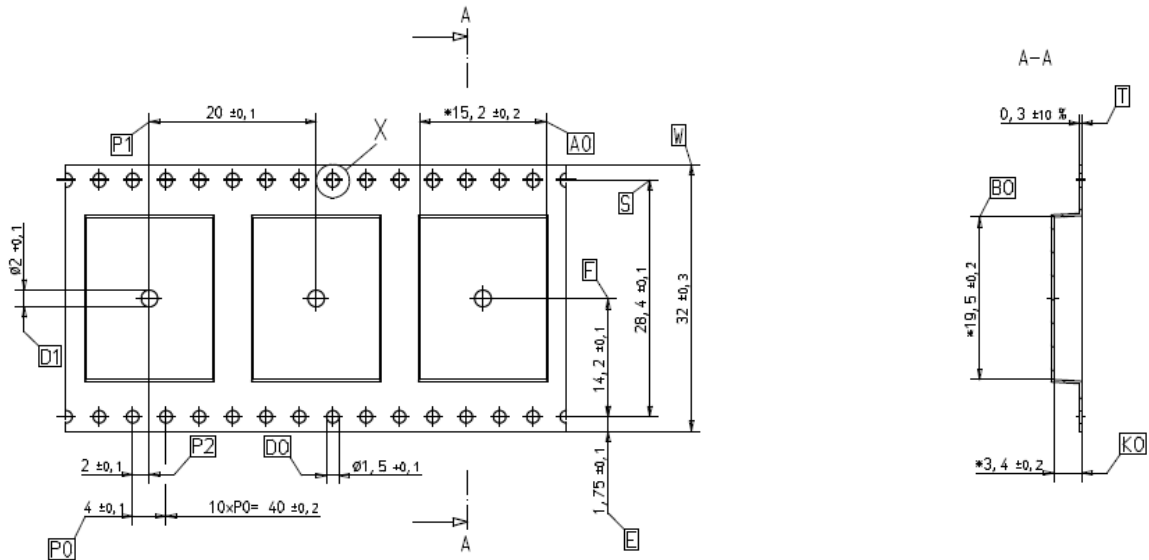

Figure 24 – Tape & Reel dimensions of TCM 515B

Figure 25 below shows the positioning of TCM 515B in the Tape & Reel packaging.

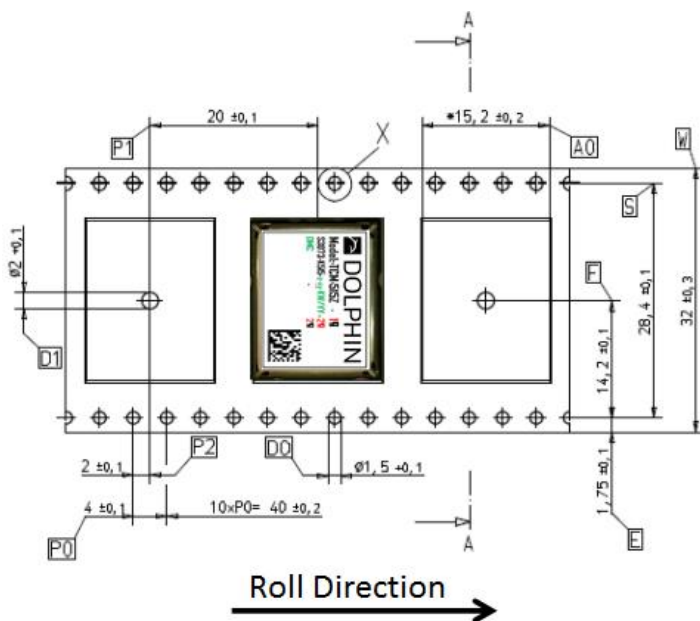

Figure 25 – Position of TCM 515B in the reel

TCM 515B – 2.4 GHZ BLUETOOTH LOW ENERGY (BLE) Transceiver

6 Application Information

6.1 Transmission Range

The main factors that influence the system transmission range are:

- Type and location of the antennas of receiver and transmitter
- Type of terrain and degree of obstruction of the link path
- Sources of interference affecting the receiver
- "Dead spots" caused by signal reflections from nearby conductive objects.

Since the expected transmission range strongly depends on this system conditions, range tests should always be performed to determine the reliably achievable range under the given conditions.

The following figures should be treated as a rough guide only:

- Line-of-sight connections
Typically 10 m range in corridors, up to 50 m in halls
- Plasterboard walls / dry wood
Typically 10 m range, through max. 2 walls
- Ferro concrete walls / ceilings
Maximum 1 wall or ceiling, depending on thickness and material
- Fire-safety walls, elevator shafts, staircases and similar areas should be considered as shielded

The angle at which the transmitted signal hits the wall is very important. The effective wall thickness – and with it the signal attenuation – varies according to this angle. Signals should be transmitted as directly as possible through the wall. Wall niches should be avoided.

Other factors restricting transmission range include:

- Switch mounting on metal surfaces (up to 30% loss of transmission range)
- Hollow lightweight walls filled with insulating wool on metal foil
- False ceilings with panels of metal or carbon fibre
- Lead glass or glass with metal coating, steel furniture

The distance between the receiver and other transmitting devices such as computers, audio and video equipment that also emit high-frequency signals should be at least 0.5 m.

7 REGULATORY INFORMATION

TCM 515B has been tested according to CE regulation. Changes or modifications not expressly approved by EnOcean could void compliance with RED requirements.

7.1 CE (RED) for European Union

According to laws of the member states of the European Union OEM manufacturer or distributor are responsible for the conformity of the product. Note the following requirements for CE certification:

The existing R&TTE directive has been replaced by RED (radio equipment directive) since 13th of June 2016.

OEM manufacturers or distributors which sell this component as a product to his (final) customers have to fulfill all requirements of the radio equipment directive (RED).

RED contains at least following requirements for OEM manufacturers or distributors:

- Provide product branding (on the product) clearly identifying company name or brand and product name as well as type, charge or serial number for market surveillance
- Include (with the product) documentation containing full postal address of the manufacturer as well as radio frequency band and max. transmitting power
- Include (with the product) user manual, safety information and a declaration of conformity for the final product in local language
- Provide product development and test documentation upon request
- OEM has to fulfill all additional requirements according to RED such as market surveillance or 10 years record retention.

For details and national translations, please see:

<http://eur-lex.europa.eu/legal-content/EN/TXT/?uri=celex:32014L0053>

TCM 515B – 2.4 GHZ BLUETOOTH LOW ENERGY (BLE) Transceiver

7.2 FCC (United States) Certificate

< to be inserted >

TCM 515B – 2.4 GHZ BLUETOOTH LOW ENERGY (BLE) Transceiver

7.2.1 FCC (United States) regulatory statement

This device complies with part 15 of the FCC Rules. Operation is subject to the following two conditions:

- (1) this device may not cause harmful interference, and
- (2) this device must accept any interference received, including interference that may cause undesired operation.

7.2.2 FCC (United States) labeling requirements

This module is labeled with its own FCC ID number, and, if the FCC ID is not visible when this module is installed inside another device, then the outside of this device into which the module is installed must also display a label referring to this enclosed module.

This exterior label can use wording such as the following:

"Contains Transmitter Module FCC ID: SVZ-TCM515B"
 Or alternatively:

"Contains FCC ID: SVZ-TCM515B"

Any similar wording that expresses the same meaning may be used. Figure 26 below shows an example of such label.

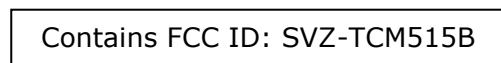

Figure 26 – Label example

7.2.3 FCC (United States) RF exposure statement

This module complies with radiofrequency radiation exposure limits according to 47 CFR, § 2.1093, applying general RF exclusion guidance KDB 447498.

Calculation of conducted output power:

conducted output power:	4.5	dBm
duty cycle correction factor:	-14	dBm
time averaged output power:	-9.5	dBm
time averaged output power:	0.1	mW

FCC output power exception limit:	$\frac{3.0 (1-g SAR) * 5 mm}{\sqrt{f(GHz)}}$
Frequency f:	2.4 GHz
Limit:	10 mW

TCM 515B – 2.4 GHZ BLUETOOTH LOW ENERGY (BLE) Transceiver

7.3 ISED (Industry Canada) Technical Acceptance Certificate

< to be inserted >

TCM 515B – 2.4 GHZ BLUETOOTH LOW ENERGY (BLE) Transceiver

7.3.1 ISED (Industry Canada) regulatory statement

This device complies with Industry Canada license-exempt RSS standard(s).
 Operation is subject to the following two conditions:

- (1) this device may not cause interference, and
- (2) this device must accept any interference, including interference that may cause undesired operation of the device.

Le présent appareil est conforme aux CNR d'Industrie Canada applicables aux appareils radio exempts de licence.

L'exploitation est autorisée aux deux conditions suivantes :

- (1) l'appareil ne doit pas produire de brouillage, et
- (2) l'utilisateur de l'appareil doit accepter tout brouillage radioélectrique subi, même si le brouillage est susceptible d'en compromettre le fonctionnement."

This radio transmitter IC: 5713A-TCM515B has been approved by Innovation, Science and Economic Development Canada to operate with the antenna types listed in chapter 4.3 with the maximum permissible gain indicated. Antenna types not included in this list that have a gain greater than the maximum gain indicated for any type listed are strictly prohibited for use with this device.

7.3.2 ISED (Industry Canada) RF exposure statement

This module complies with the Exemption Limits for Routine Evaluation of radiofrequency radiation exposure according to RSS-102, 2.5.1.

Calculation of e.i.r.p. (effective isotropic radiated power):

conducted output power:	4.5	dBm
maximum gain of antenna:	5.0	dBi
maximum e.i.r.p.:	9.5	dBm
duty cycle correction factor	-14	dBm
time averaged e.i.r.p	-4.5	dBm
time averaged e.i.r.p	0.4	mW

ISED Exemption limit for time-averaged e.i.r.p output power

Frequency f:	2450	MHz
Limit	4	mW

Source: [https://www.ic.gc.ca/eic/site/smt-gst.nsf/vwapj/rss-102-issue5.pdf/\\$file/rss-102-issue5.pdf](https://www.ic.gc.ca/eic/site/smt-gst.nsf/vwapj/rss-102-issue5.pdf/$file/rss-102-issue5.pdf)