

Nemko-CCL, Inc.
1940 West Alexander Street
Salt Lake City, UT 84119
801-972-6146

Test Report

Certification/Class II Permissive Change

Test Of: TCM 300U, TCM 310U, and STM 300U

Test Specifications:

FCC Part 15, Subpart C

FCC ID: SZV-STM300U

Test Report Serial No: 234766-3.2

Applicant:
EnOcean GmbH
Kolpingring 18a
Oberhaching 82041
Germany

Date of Test: May 30, 2013

Report Issue Date: June 4, 2013

Accredited Testing Laboratory By:



NVLAP Lab Code 100272-0

CERTIFICATION OF ENGINEERING REPORT

This report has been prepared by Nemko-CCL, Inc. to document compliance of the device described below with the certification requirements of FCC Part 15, Subpart C. This report may be reproduced in full. Partial reproduction of this report may only be made with the written consent of the laboratory. The results in this report apply only to the sample tested.

- Applicant: EnOcean GmbH
- Manufacturer: EnOcean GmbH
- Brand Name: EnOcean
- Model Number: TCM 300U, TCM 310U, and STM 300U
- FCC ID: SZV-STM300U

On this 4th day of June 2013, I, individually and for Nemko-CCL, Inc., certify that the statements made in this engineering report are true, complete, and correct to the best of my knowledge, and are made in good faith.

Although NVLAP has accredited the Nemko-CCL, Inc. EMC testing facilities, this report must not be used to claim product certification, approval, or endorsement by NVLAP, NIST, or any agency of the federal government.

Nemko-CCL, Inc.



Tested by: Norman P. Hansen
Test Technician



Reviewed by: Thomas C. Jackson
General Manager

TABLE OF CONTENTS

	PAGE
<u>SECTION 1.0 CLIENT INFORMATION</u>	4
<u>SECTION 2.0 EQUIPMENT UNDER TEST (EUT)</u>	5
<u>SECTION 3.0 TEST SPECIFICATION, METHODS & PROCEDURES</u>	7
<u>SECTION 4.0 OPERATION OF EUT DURING TESTING</u>	11
<u>SECTION 5.0 SUMMARY OF TEST RESULTS</u>	12
<u>SECTION 6.0 MEASUREMENTS, EXAMINATIONS AND DERIVED RESULTS</u>	13
<u>APPENDIX 1 TEST PROCEDURES AND TEST EQUIPMENT</u>	17
<u>APPENDIX 2 PHOTOGRAPHS</u>	20
<u>APPENDIX 3 TEST RESULTS FROM ORIGINAL CERTIFICATION</u>	26

SECTION 1.0 CLIENT INFORMATION

1.1 Applicant:

Company Name: EnOcean GmbH
Kolpingring 18a
Oberhaching 82041
Germany

Contact Name: Armin Anders
Title: Director Product Marketing

1.2 Manufacturer:

Company Name: EnOcean GmbH
Kolpingring 18a
Oberhaching 82041
Germany

Contact Name: Armin Anders
Title: Director Product Marketing

SECTION 2.0 EQUIPMENT UNDER TEST (EUT)**2.1 Identification of EUT:**

Brand Name: EnOcean GmbH
 Model Number: TCM 300U, TCM 310U, and STM 300U
 Serial Number/Unit Identifier: 0088A3D1

2.2 Description of EUT:

The TCM 300U, TCM 310U, and STM 300U are modules with a 902.9 MHz transceiver. The modules are designed for incorporation into other devices used in alarm and control applications operating at 902.9 MHz. 3.3 VDC is provided to the TCM 300U, TCM 310U, and STM 300U by the host system. The TCM 300U, TCM 310U, and STM 300U were previously certified using either a wire whip antenna or a helical wire antenna. The units tested now, for a class II permissive change, use a Mitsubishi Materials AM11DG-ST01 antenna. The power setting to be incorporated in the production firmware is +1, the same as used in previous testing and certification using the other antennas. The only difference between the STM 300U, TCM 300U, and TCM 310U is the firmware for the module interface lines.

This report covers the transceiver circuitry of the device subject to FCC Part 15, Subpart C. The circuitry of the device, subject to FCC Part 15, Subpart B, was tested, found compliant, and is covered in Nemko-CCL, Inc. report #224951-1.

2.3 EUT and Support Equipment:

Brand Name Model Number Serial No.	FCC ID	Description	Name of Interface Ports / Interface Cables
BN: EnOcean MN: TCM 300U (Note 1) SN: 0088A3D1	SZV-STM300U	902.9 MHz transmitter module	See Section 2.4
BN: EnOcean MN: TCM 310U SN: None	SZV-STM300U	902.9 MHz transmitter module	See Section 2.4
BN: EnOcean MN: STM 300U SN: None	SZV-STM300U	902.9 MHz transmitter module	See Section 2.4

Note: (1) EUT

The support equipment listed above was not modified in order to achieve compliance with this standard.

2.4 Interface Ports on EUT:

Name of Ports	No. of Ports Fitted to EUT	Cable Descriptions/Length
Module to System Interface (normally soldered directly to host PCB assembly)	1	Power conductors/ extended to 16.5 cm for testing

2.5 Modification Incorporated/Special Accessories on EUT:

There were no modifications or special accessories required to comply with the specification.

SECTION 3.0 TEST SPECIFICATION, METHODS & PROCEDURES

3.1 Test Specification:

Title: FCC PART 15, Subpart C (47 CFR 15)
Section 15.203, Section 15.207, and Section 15.231

Periodic operation in the band 40.66-40.70 MHz and above 70 MHz.

Purpose of Test: The tests were performed to demonstrate compliance for a class II permissive change to the device certification when using the AM11DG-ST01 antenna.

3.2 Methods & Procedures:

3.2.1 §15.203

An intentional radiator shall be designed to ensure that no antenna other than that furnished by the responsible party shall be used with the device. The use of a permanently attached antenna or of an antenna that uses a unique coupling to the intentional radiator shall be considered sufficient to comply with the provisions of this Section. The manufacturer may design the unit so that a broken antenna can be replaced by the user, but the use of a standard antenna jack or electrical connector is prohibited. This requirement does not apply to carrier current devices or to devices operated under the provisions of Sections 15.211, 15.213, 15.217, 15.219, or 15.221. Further, this requirement does not apply to intentional radiators that must be professionally installed, such as perimeter protection systems and some field disturbance sensors, or to other intentional radiators which, in accordance with Section 15.31(d), must be measured at the installation site. However, the installer shall be responsible for ensuring that the proper antenna is employed so that the limits in this Part are not exceeded.

3.2.2 §15.207 Conducted Limits

(a) Except for Class A digital devices, for equipment that is designed to be connected to the public utility (AC) power line, the radio frequency voltage that is conducted back onto the AC power line on any frequency or frequencies within the band 150 kHz to 30 MHz shall not exceed the limits in the following table, as measured using a 50 μ H/50 ohms line impedance stabilization network (LISN). Compliance with the provisions of this paragraph shall be based on the measurement of the radio frequency voltage between each power line and ground at the power terminal. The lower limit applies at the band edges.

Frequency of Emission (MHz)	Conducted Limit (dB μ V)	
	Quasi-peak	Average
0.15 – 0.5*	66 to 56*	56 to 46*
0.5 – 5	56	46
5 - 30	60	50

*Decreases with the logarithm of the frequency.

3.2.2 §15.231

(a) The provisions of this section are restricted to periodic operation within the band 40.66-40.70 MHz and above 70 MHz. Except as Shown in paragraph (e) of this section, the intentional radiator is restricted to the transmission of a control signal such as those used with alarm systems, door openers, remote switches, etc. Radio control of toys is not permitted. Continuous transmissions, such as voice or video, and data transmissions are not permitted. The prohibition against data transmissions does not preclude the use of recognition codes. Those codes are used to identify the sensor that is activated or to identify the particular component as being part of the system. The following conditions shall be met to comply with the provisions for this periodic operation:

(1) A manually operated transmitter shall employ a switch that will automatically deactivate the transmitter within not more than 5 seconds of being released.

(2) A transmitter activated automatically shall cease transmission within 5 seconds after activation.

(3) Periodic transmissions at regular predetermined intervals are not permitted. However, polling or supervision transmission to determine system integrity of transmitters used in security or safety applications are allowed if the periodic rate of transmission does not exceed one transmission of not more than one second duration per hour for each transmitter.

(4) Intentional radiators which are employed for radio control purposes during emergencies involving fire, security, and safety of life, when activated to signal an alarm, may operate during the pendency of the alarm condition.

(b) In addition to the provisions of §15.205, the field strength of emission from intentional radiators operated under this section shall not exceed the following:

Fundamental frequency (MHz)	Field strength of fundamental (microvolts/meter)	Field strength of spurious emissions (microvolts/meter)
40.66 - 40.70	2,250	225
70 –130	1,250	125
130 – 174	1,250 to 3,750 **	125 to 375 **
174 – 260	3,750	375
260 – 470	3,750 to 12,500 **	375 to 1,250 **
Above 470	12,500	1,250

** Linear interpolations

[Where F is the frequency in MHz, the formula for calculating the maximum permitted field strengths are as follows: for the band 130 – 174 MHz, $\mu\text{V/m}$ at 3 meters = $56.81818(F) - 6136.3636$; for the band 260 – 470 MHz, $\mu\text{V/m}$ at 3 meters = $41.6667(F) - 7083.3333$. The maximum permitted unwanted emission level is 20 dB below the maximum permitted fundamental level.]

(1) The above field strength limits are specified at a distance of 3 meters. The tighter limits apply at the band edges.

(2) Intentional radiators operating under the provisions of this section shall demonstrate compliance with the limits on the field strength of emissions, as shown in the above table, based on the average value of the measured emissions. As an alternative, compliance with the limits in the above table may be based on the use of measurement instrumentation with a CISPR quasi-peak detector. The specific method of measurement employed shall be specified in the application for equipment authorization. If average emission measurements are employed, the provision in §15.35 for averaging pulsed emission and for limiting peak emissions apply. Further, compliance with the provisions of §15.205 shall be demonstrated using the measurement instrumentation specified in that section.

(3) The limits on the field strength of the spurious emission in the above table are based on the fundamental frequency of the intentional radiator. Spurious emission shall be attenuated to the average (or, alternatively, CISPR quasi-peak) limits shown in this table or to the general limits shown in §15.209, whichever limit permits a higher field strength.

(c) The bandwidth of the emission shall be no wider than 0.25% of the center frequency for devices operating above 70 MHz and below 900 MHz. For devices operating above 900 MHz, the emission shall be no wider than 0.5% of the center frequency. Bandwidth is determined at the points 20 dB down from the modulated carrier.

(d) For devices operation within the frequency band 40.66-40.70 MHz, the bandwidth of the emission shall be confined within the band edges and the frequency tolerance of the carrier shall be $\pm 0.01\%$. This frequency tolerance shall be maintained for a temperature variation of -20 degrees to +50 degrees C at normal supply voltage, and for a variation on the primary supply

voltage from 85% to 115% of the rated supply voltage at a temperature of 20 degrees C. For battery operated equipment, the equipment tests shall be performed using a new battery.

(e) Intentional radiators may operate at a periodic rate exceeding that specified in paragraph (a) of this section and may be employed for any type of operation, including operation prohibited in paragraph (a) of this section, provided that intentional radiator complies with the provisions of paragraphs (b) through (d) of this section except the field strength table in paragraph (b) of this section is replaced by the following:

Fundamental frequency (MHz)	Field strength of fundamental (microvolts/meter)	Field strength of spurious emissions (microvolts/meter)
40.66 - 40.70	1,000	100
70 –130	500	50
130 – 174	500 to 1,500 **	50 to 150 **
174 – 260	1,500	150
260 – 470	1,500 to 5,000 **	150 to 500 **
Above 470	5,000	500

** Linear interpolations

[Where F is the frequency in MHZ, the formula for calculating the maximum permitted field strengths are as follows: for the band 130 – 174 MHz, $\mu\text{V/m}$ at 3 meters = $22.72727(F) - 2454.545$; for the band 260 – 470 MHz, $\mu\text{V/m}$ at 3 meters = $16.6667(F) - 2833.3333$. The maximum permitted unwanted emission level is 20 dB below the maximum permitted fundamental level.]

In addition, devices operated under the provisions of this paragraph shall be provided with a means for automatically limiting operation so that the duration of each transmission shall not be greater than one second and the silent periods between transmissions shall be at least 30 times the duration of the transmission but in no case less than 10 seconds.

3.2.3 Test Procedure

The conducted disturbance at mains ports and radiated disturbance testing was performed according to the procedures in ANSI C63.4: 2003, 47 CFR Part 15, and using the guidance, DA 00-705, Filing and Measurement Guidelines for Frequency Hopping Spread Spectrum Systems, dated March 30, 2000. Testing was performed at Nemko-CCL, Inc. Wanship open area test site #2, located at 29145 Old Lincoln Highway, Wanship, UT. This site has been registered with the FCC, and was renewed February 15, 2012 (90504). This registration is valid for three years.

Nemko-CCL, Inc. is accredited by National Voluntary Laboratory Accreditation Program (NVLAP); NVLAP Lab Code: 100272-0, which is effective until September 30, 2013.

SECTION 4.0 OPERATION OF EUT DURING TESTING

4.1 Operating Environment:

Power Supply: 3.3 VDC

4.2 Operating Modes:

Each mode of operation was exercised to produce worst-case emissions. The EUT was tested on 3 orthogonal axes while constantly transmitting. A 3.3 VDC battery was extended 16.5 cm from the EUT and used as a power source for radiated emission testing.

4.3 EUT Exercise Software:

EnOcean test software was used to control the transmitter.

SECTION 5.0 SUMMARY OF TEST RESULTS**5.1 FCC Part 15, Subpart C****5.1.1 Summary of Tests:**

Part 15, Subpart C Reference	Test Performed	Frequency Range (MHz)	Result
15.203	Antenna Requirement	N/A	Complied
15.207	Conducted Emissions at the AC Mains	0.15 to 30	Complied (Note 1)
15.231 (a)	Periodic Operation	902.9	Complied (Note 1)
15.231 (b)	Radiated Emissions	0.15 to 9029	Complied
15.231 (c)	Bandwidth	902.9	Complied
15.231 (d)	Frequency Stability	40.66 to 40.70	Not Applicable
15.231 (e)	Radiated Emissions	0.15 to 9029	Not Applicable

Note 1: These tests were not performed on this unit as the circuitry of the device was not changed except for an antenna change that should not change the results from the original certification test results reported in Nemko-CCL report #224951-2 dated January 2, 2013. These results are included as a reference in Appendix 3.

5.2 Result

In the configuration tested, the EUT complied with the requirements of the specification.

SECTION 6.0 MEASUREMENTS, EXAMINATIONS AND DERIVED RESULTS**6.1 General Comments:**

This section contains the test results only. Details of the test methods used and a list of the test equipment used during the measurements can be found in Appendix 1 of this report.

6.2 Test Results:**6.2.1 §15.203**

The antenna is a Mitsubishi Materials AM11DG-ST01 and is soldered to the PCB. It is not user replaceable.

RESULT

The EUT complied with the requirements of this section.

6.2.3 §15.231 (b) Radiated Emissions

The EUT operates at 902.9 MHz, therefore; the field strength of the fundamental must be less than 12,500 $\mu\text{V/m}$ (81.9 $\text{dB}\mu\text{V/m}$) at 3 meters. The maximum permitted field strength of any unwanted emission must be 20 dB below the maximum allowable fundamental field strength (61.9 $\text{dB}\mu\text{V/m}$).

Emissions in the restricted bands of §15.205 must meet the limits specified in §15.209.

Measurement Data Fundamental and Harmonic Emissions:

The frequency range from the lowest frequency to the tenth harmonic of the highest fundamental frequency was investigated to measure any radiated emissions.

Pulsed Emission Averaging Factor

The EUT uses a pulsed emission that provides an averaging factor of -20.0 dB. The calculations and plots of the emission pulse train are shown in Appendix 3.

Radiated Interference Measurements – (Vertical Polarity)

Frequency (MHz)	Detector	Receiver Reading (dB μ V)	Correction Factor (dB/m)	Average Factor (dB)	Field Strength (dB μ V/m)	Limit (dB μ V/m)	Delta (dB)
902.9	Peak	69.6	30.7	-20.0	80.3	81.9	-1.6
1805.8	Peak	15.6	29.9	-20.0	25.5	61.9	-36.4
2708.6*	Peak	4.8	32.9	-20.0	17.7	54.0	-36.3
3611.5*	Peak	5.9	35.8	-20.0	21.7	54.0	-32.3
4514.4*	Peak	4.4	37.1	-20.0	21.5	54.0	-32.5
5417.3*	Peak	3.7	39.1	-20.0	22.8	54.0	-31.2
6320.1	Peak	2.8	39.8	-20.0	22.6	61.9	-39.3
7223.0	Peak	2.8	41.8	-20.0	24.6	61.9	-37.3
8125.9*	Peak	3.0	43.3	-20.0	26.3	54.0	-27.7
9029.0*	Peak	1.8	44.4	-20.0	26.2	54.0	-27.8
* Emissions within restricted bands							

Radiated Interference Measurements - (Horizontal Polarity)

Frequency (MHz)	Detector	Receiver Reading (dB μ V)	Correction Factor (dB/m)	Average Factor (dB)	Field Strength (dB μ V/m)	Limit (dB μ V/m)	Delta (dB)
902.9	Peak	69.0	30.7	-20.0	79.7	81.9	-2.2
1805.8	Peak	14.8	29.9	-20.0	24.7	61.9	-37.2
2708.6*	Peak	5.4	32.9	-20.0	18.3	54.0	-35.7
3611.5*	Peak	6.7	35.8	-20.0	22.5	54.0	-31.5
4514.4*	Peak	4.2	37.1	-20.0	21.3	54.0	-32.7
5417.3*	Peak	4.0	39.1	-20.0	23.1	54.0	-30.9
6320.1	Peak	3.2	39.8	-20.0	23.0	61.9	-38.9
7223.0	Peak	2.3	41.8	-20.0	24.1	61.9	-37.8
8125.9*	Peak	2.7	43.3	-20.0	26.0	54.0	-28.0
9029.0*	Peak	1.7	44.4	-20.0	26.1	54.0	-27.9
* Emissions within restricted bands							

Sample Field Strength Calculation:

The field strength is calculated by adding the Correction Factor (Antenna Factor + Cable Factor) and the Average Factor to the measured level of the receiver. The receiver amplitude reading is compensated for any amplifier gain.

The basic equation with a sample calculation is shown below:

$$FS = RA + CF + AV \text{ Where}$$

FS = Field Strength

RA = Receiver Amplitude Reading

CF = Correction Factor (Antenna Factor + Cable Factor)

AV = Averaging Factor

Assume a receiver reading of 44.2 dB μ V is obtained from the receiver, with an average factor of -8.6 dB and a correction factor of 17.5 dB. The field strength is calculated by adding the correction factor and the average factor, giving a field strength of 53.1 dB μ V/m, $FS = 44.2 + 17.5 + (-8.6) = 53.1$ dB μ V/m

RESULT

In the configuration tested, the EUT complied with the requirements of this section.

6.2.4 §15.231 (c) Bandwidth

The bandwidth of the emission must not be wider than 0.25% of the center frequency. The center frequency is 902.9 MHz, therefore the bandwidth must not be wider than 2.257 MHz. The EUT bandwidth was 287.0 kHz. See spectrum analyzer plot below.

Bandwidth Plot

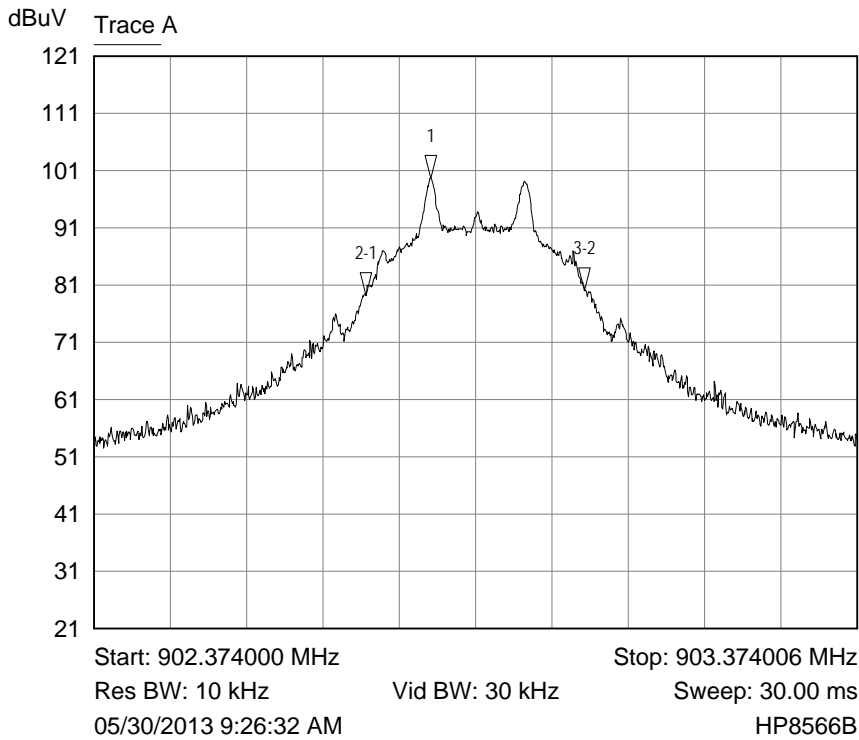

Mkr	X-Axis	Value	Notes
1 ▽	902.815003 MHz	99.7000 dBuV	
2-1 ▽	-85.000511 kHz	-20.5000 dB	
3-2 ▽	287.001723 kHz	0.8000 dB	

Trace A Band Width

RESULT

In the configuration tested, the EUT complied with the requirements of this section.

APPENDIX 1 TEST PROCEDURES AND TEST EQUIPMENT

A1.2 Radiated Disturbance:

The radiated disturbance from the EUT was measured using a spectrum analyzer with a quasi-peak adapter for peak and quasi-peak readings.

A preamplifier with a fixed gain of 26 dB was used to increase the sensitivity of the measuring instrumentation. The quasi-peak adapter uses a bandwidth of 120 kHz, with the spectrum analyzer's resolution bandwidth set at 1 MHz, for readings in the 30 to 1000 MHz frequency ranges. A 31 dB preamp was used for measurements above 1000 MHz with the spectrum analyzer RBW set to 1 MHz and VBW at 3 MHz..

A loop antenna was used to measure emissions below 30 MHz. Emission readings more than 20 dB below the limit at any frequency may not be listed in the reported data. For frequencies between 9 kHz and 30 MHz, or the lowest frequency generated or used in the device greater than 9 kHz, and less than 30 MHz, the spectrum analyzer resolution bandwidth was set to 9 kHz and the video bandwidth was set to 30 kHz. For average measurements, the spectrum analyzer average detector was used.

For frequencies above 30 MHz, an amplifier and preamplifier were used to increase the sensitivity of the measuring instrumentation. The quasi-peak adapter uses a bandwidth of 120 kHz, with the spectrum analyzer's resolution bandwidth set at 1 MHz, for readings in the 30 to 1000 MHz frequency ranges. For peak emissions above 1000 MHz the spectrum analyzer's resolution bandwidth was set to 1 MHz and the video bandwidth was set to 3 MHz. For average measurements above 1000 MHz the spectrum analyzer's resolution bandwidth was set to 1 MHz and the average detector of the analyzer was used.

A biconilog antenna was used to measure the frequency range of 30 to 1000 MHz, at a distance of 3 meters from the EUT. The readings obtained by these antennas are correlated to the levels obtained with a tuned dipole antenna by adding antenna factors. A double-ridged guide antenna was used to measure the emissions at frequencies above 1000 MHz at a distance of 3 meters from the EUT.

The configuration of the EUT was varied to find the maximum radiated emission. The EUT was connected to the peripherals listed in Section 2.3 via the interconnecting cables listed in Section 2.4. A technician manually manipulated these interconnecting cables to obtain worst-case radiated disturbance. The EUT was rotated 360 degrees, and the antenna height was varied from 1 to 4 meters to find the maximum radiated emission. Where there were multiple interface ports all of the same type, cables are either placed on all of the ports or cables added to these ports until the emissions do not increase by more than 2 dB.

Desktop EUT are measured on a non-conducting table 0.8 meters above the ground plane. The table is placed on a turntable, which is level with the ground plane. For equipment normally placed on floors, the equipment shall be placed directly on the turntable.

For radiated emission testing at 30 MHz or above that is performed at distances closer than the specified distance, an inverse proportionality factor of 20 dB per decade is used to normalize the measured data for determining compliance.

Type of Equipment	Manufacturer	Model Number	Serial Number	Date of Last Calibration	Due Date of Calibration
Wanship Open Area Test Site #2	Nemko-CCL, Inc.	N/A	N/A	12/07/2012	12/07/2013
Test Software	Nemko-CCL, Inc.	Radiated Emissions	Revision 1.3	N/A	N/A
Spectrum Analyzer/Receiver	Rhode & Schwarz	ESU40	100064	07/28/2012	07/28/2013
Spectrum Analyzer	Hewlett Packard	8566B	2230A01711	02/06/2013	02/06/2014
Quasi-Peak Detector	Hewlett Packard	85650A	2043A00137	02/06/2013	02/06/2014
Loop Antenna	EMCO	6502	9111-2675	03/04/2013	03/04/2015
Biconilog Antenna	EMCO	3142	9601-1008	10/10/2012	10/10/2014
Double Ridged Guide Antenna	EMCO	3115	9409-4355	06/06/2012	06/06/2014
High Frequency Amplifier	Miteq	AFS4-01001800-43-10P-4	1096455	05/06/2013	05/06/2014
20' High Frequency Cable	Microcoax	UFB197C-1-3120-000000	1297	05/02/2013	05/02/2014
3 Meter Radiated Emissions Cable Wanship Site #2	Microcoax	UFB205A-0-4700-000000	1295	05/02/2013	05/02/2014
Pre/Power-Amplifier	Hewlett Packard	8447F	3113A05161	08/27/2012	08/27/2013
6 dB Attenuator	Hewlett Packard	8491A	32835	12/21/2012	12/21/2013

An independent calibration laboratory or Nemko-CCL, Inc. personnel calibrates all the equipment listed above at intervals defined in ANSI C63.4:2003 Section 4.4 following outlined calibration procedures. All measurement instrumentation is traceable to the National Institute of Standards and Technology (NIST). Supporting documentation relative to tractability is on file and is available for examination upon request.

Radiated Emissions Test Setup

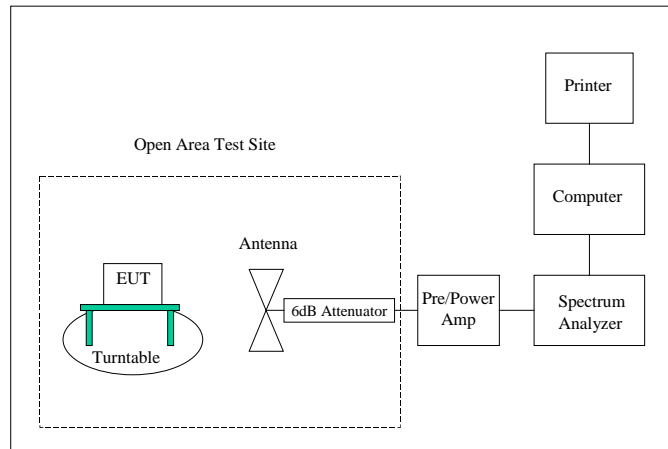

APPENDIX 2 PHOTOGRAPHS

Photograph 1 – Front View Radiated Disturbance – On Edge Configuration

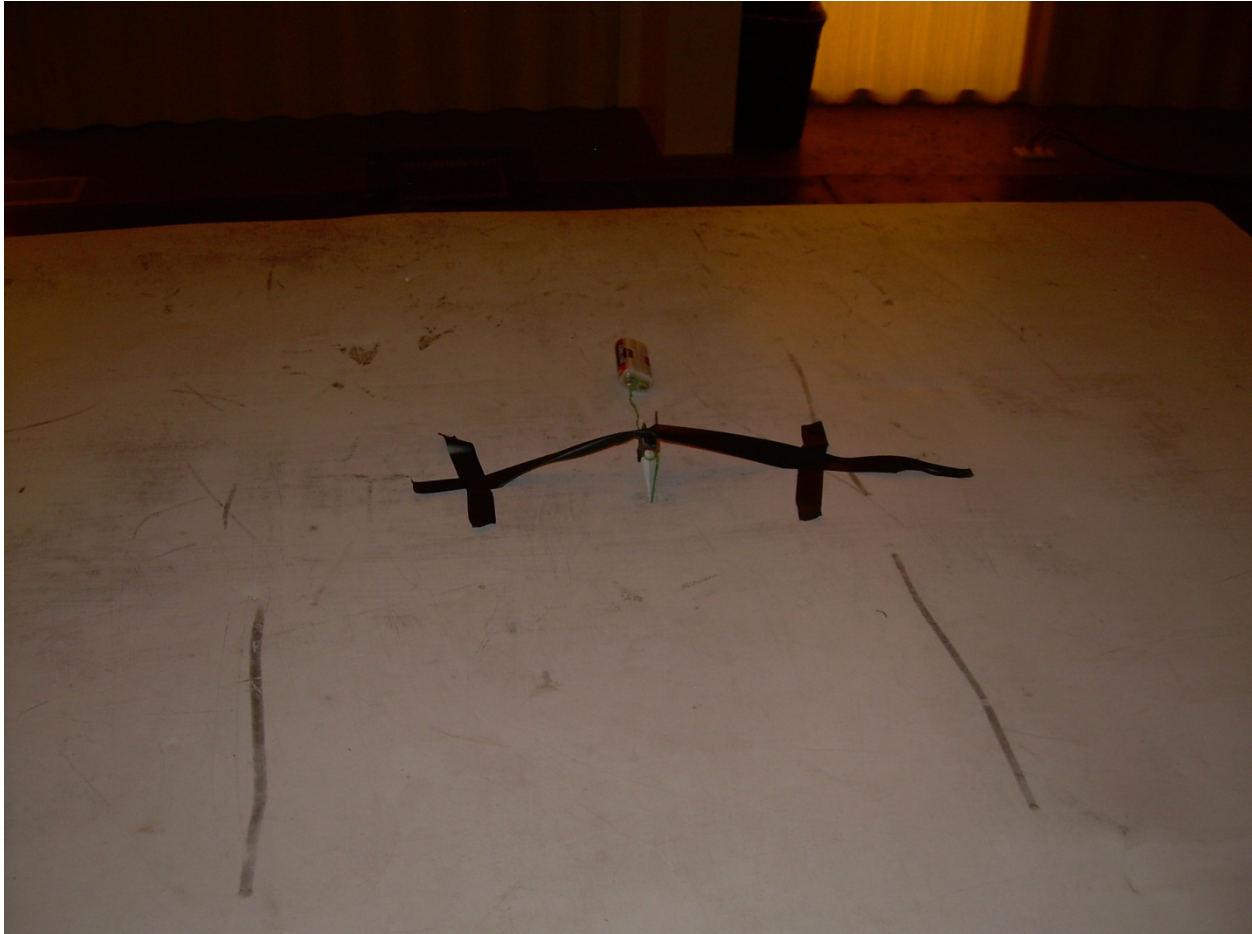

Photograph 2 – View Radiated Disturbance – Horizontal Configuration



Photograph 3 – View Radiated Disturbance – Vertical Configuration

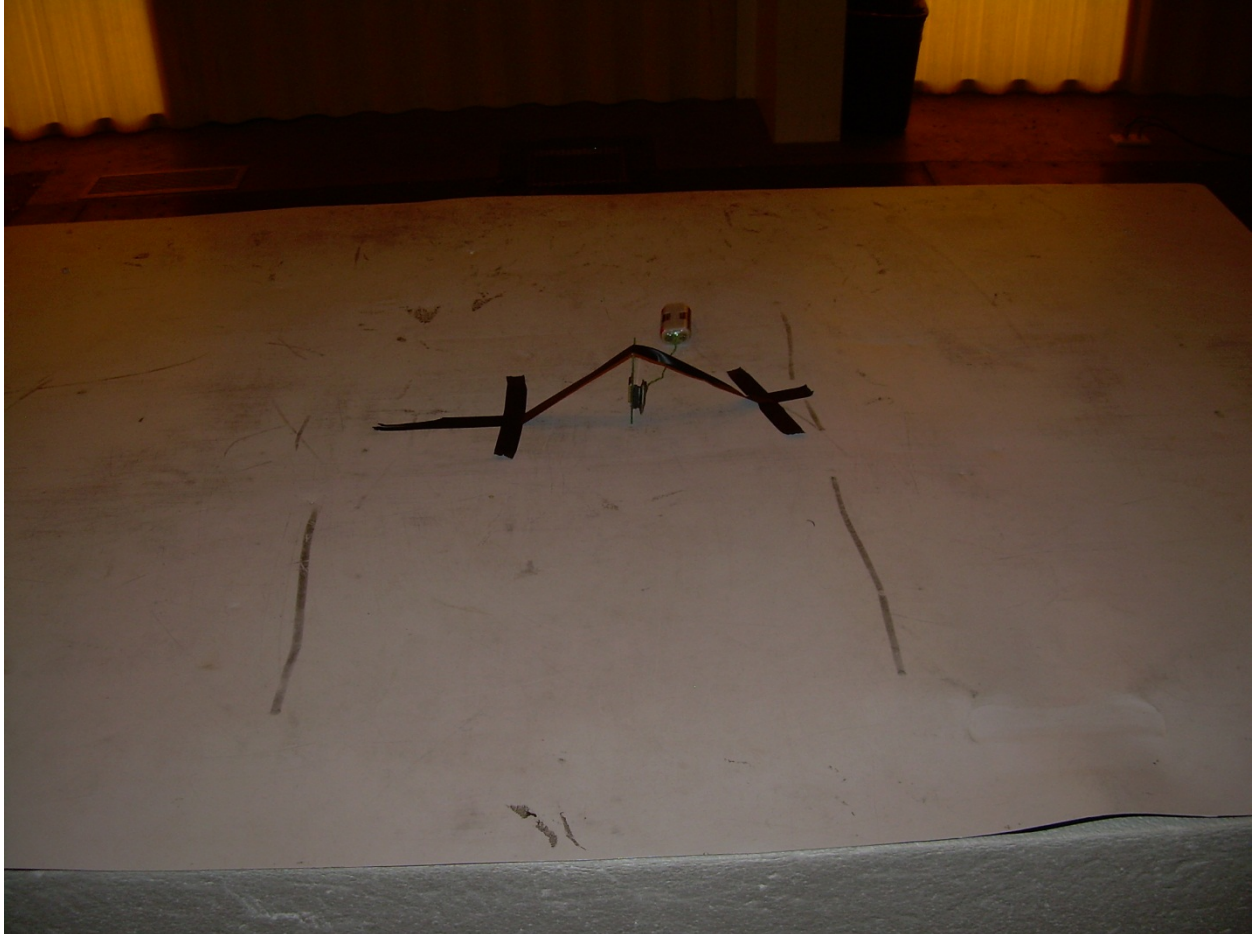

Photograph 4 – Front View of the Module and Antenna

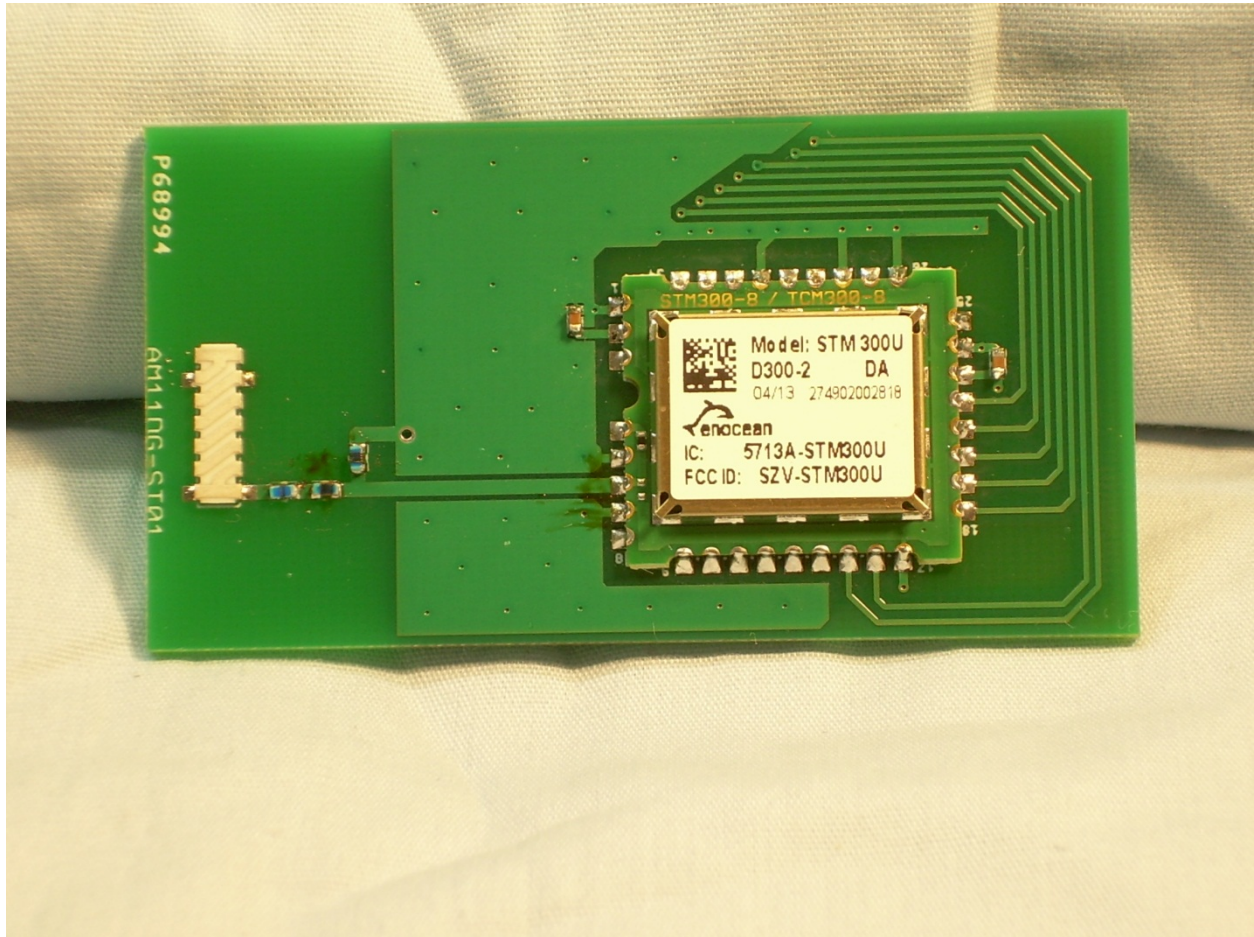

Photograph 5 – Back View of the PCB with Module Interface Connector

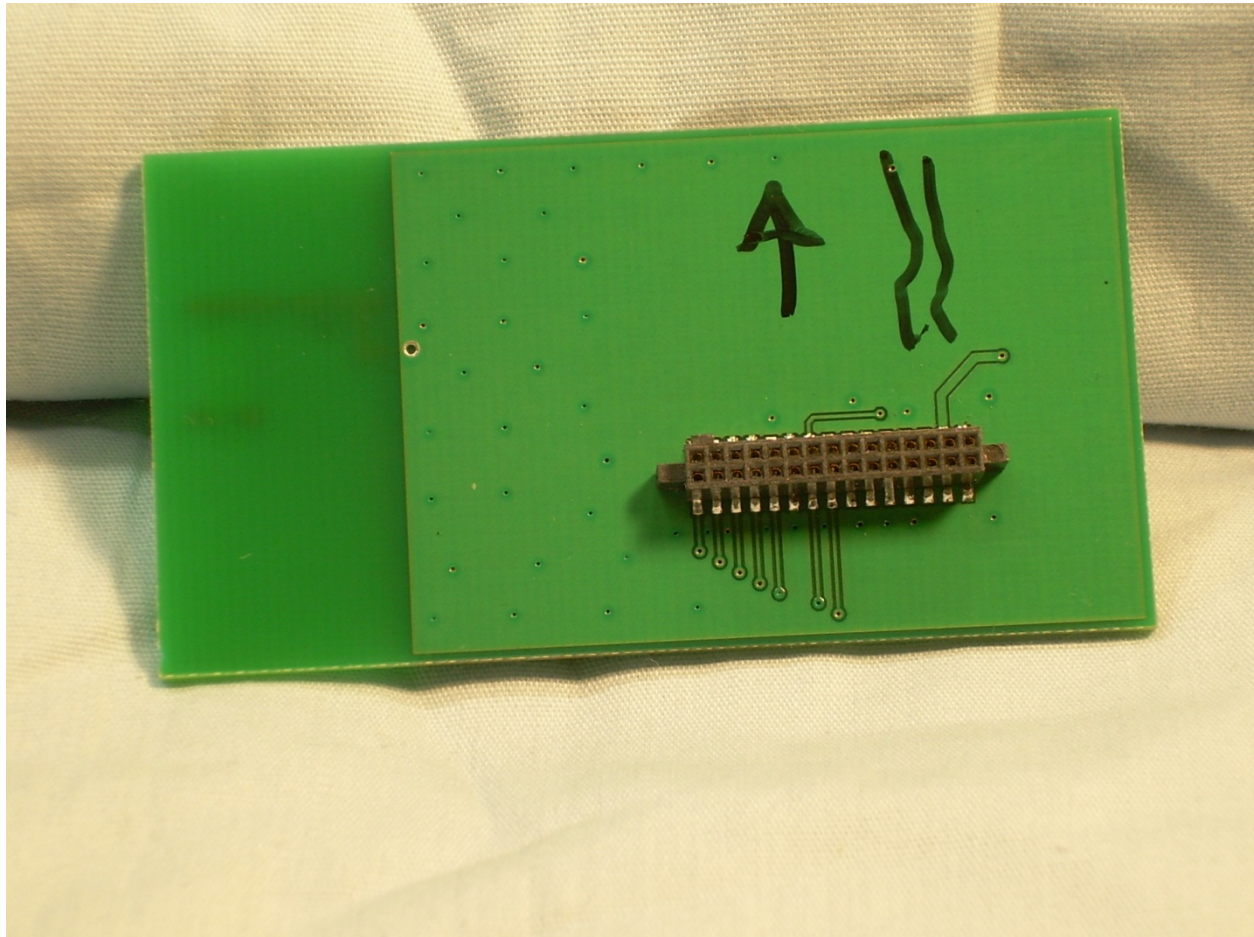

Photograph 6 – View of the Circuitry Under RF Shield



APPENDIX 3 TEST RESULTS FROM ORIGINAL CERTIFICATION

The test results shown below are from testing performed for the original certification and documented in Nemko-CCL report #224951-2, dated January 2, 2013.

A3.1 §15.207 Conducted Emissions at the AC Mains

Testing was performed using a Sino-American R4W005-100 power supply to power the EUT.

Frequency (MHz)	Line	Detector	Measured Level (dB μ V)	Class B Limit (dB μ V)	Margin (dB)
0.15	Hot Lead	Peak (Note 1)	51.0	56.0	-5.0
0.20	Hot Lead	Peak (Note 1)	49.0	53.5	-4.5
0.23	Hot Lead	Peak (Note 1)	47.1	52.4	-5.3
0.27	Hot Lead	Peak (Note 1)	46.6	51.2	-4.6
0.39	Hot Lead	Peak (Note 1)	41.0	48.1	-7.1
0.48	Hot Lead	Peak (Note 1)	39.4	46.3	-6.9
0.19	Neutral Lead	Peak (Note 1)	46.7	54.1	-7.4
0.23	Neutral Lead	Peak (Note 1)	41.7	52.5	-10.8
0.27	Neutral Lead	Peak (Note 1)	41.2	51.1	-9.9
0.34	Neutral Lead	Peak (Note 1)	38.4	49.1	-10.7
0.42	Neutral Lead	Peak (Note 1)	37.8	47.4	-9.6
0.49	Neutral Lead	Peak (Note 1)	35.3	46.1	-10.8

Note 1: The reference detector used for the measurements was Quasi-Peak or Peak and the data was compared to the average limit; therefore, the EUT was deemed to meet both the average and quasi-peak limits.

RESULT

The EUT complied with the specification limit by a margin of 4.5 dB.

A3.2 §15.231 (a) Emission Characteristics and Timing

1. The EUT is not manually activated.
2. The EUT is automatically activated when a module interface line is activated. The EUT firmware limits the transmission to 3 pulses in 100 ms no matter how often the interface line is activated. See the plots below.

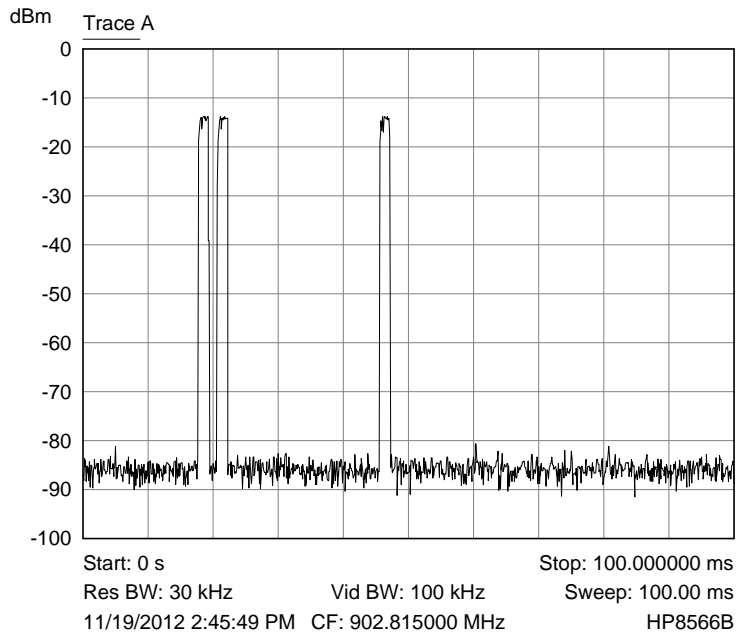
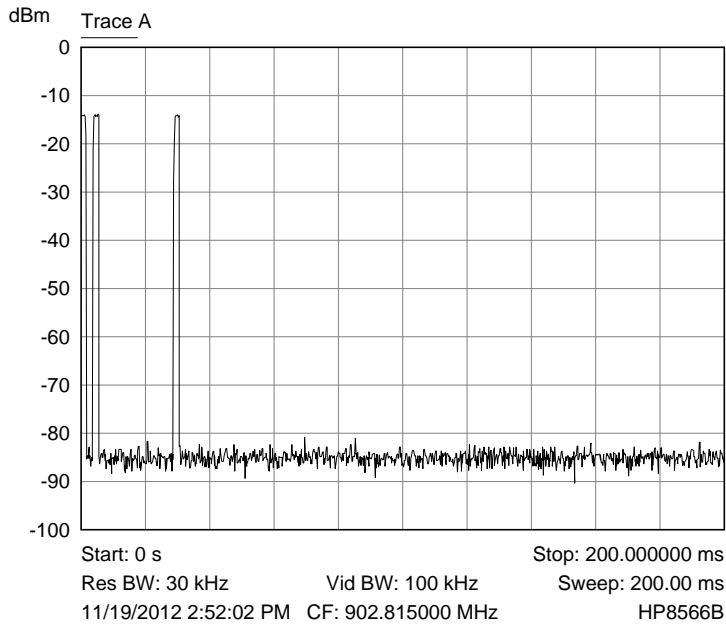

3. The EUT does not transmit at regular predetermined intervals.
4. The EUT is not used during an emergency that involves fire and safety of life.
5. The EUT does not require set up information transmissions by a professional installer.

RESULT

In the configuration tested, the EUT complied with the requirements of this section.

A3.3 §15.35 Pulsed Emission Averaging

Pulsed Emission Averaging Factor

The TCM 300U, TCM 310U, and STM 300U transmitter is a pulsed emission; therefore, the method of §15.35 for averaging a pulsed emission may be used. A timing diagram of the pulsed transmission, plots of the pulse train, and the average factor calculations are shown below:

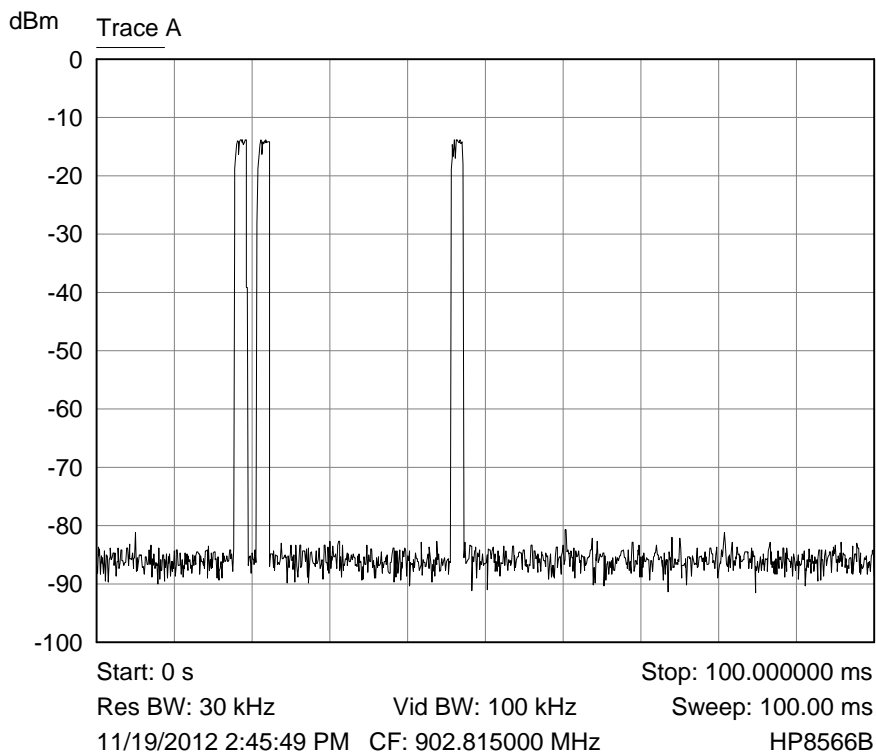

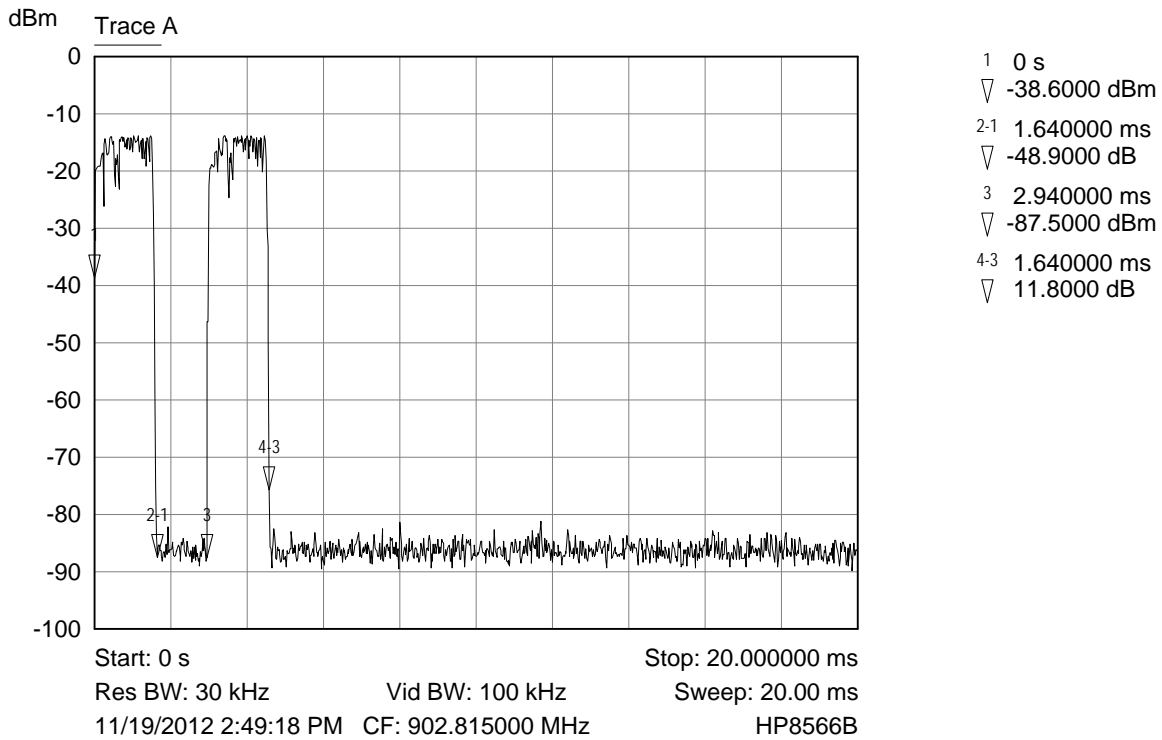

Average factor calculation

From the plots, there are 3 pulses transmitted in 100 milliseconds. The maximum time for averaging the emission using FCC §15.35(c) is 100 ms. The Average Factor will be calculated using 100 ms as specified in FCC §15.35(c).

The Average Factor is calculated by the equation:

$$\text{Average Factor} = 20 \log (\text{on time}/\text{pulse train time})$$

Pulse train time = 100 ms per FCC §15.35(c)

On time = 1.64 ms x 3 = 4.92 ms

$$\begin{aligned} \text{Average Factor} &= 20 \log (4.92 / 100) \\ &= -26.2 \text{ dB} \end{aligned}$$

§15.35(b) specifies a 20 dB maximum between the peak and average measurements; therefore, a -20.0 dB averaging factor will be used.