



PHOENIX
TESTLAB

Königswinkel 10

32825 Blomberg

Germany

Phone: +49 (0) 52 35 95 00-0

Fax: +49 (0) 52 35 95 00-10

Test Report

Report Number: F112808E1

Applicant:

EnOcean GmbH

Manufacturer:

EnOcean GmbH

Equipment under Test (EUT):

PTM210 C

Laboratory (CAB) accredited by
Deutsche Gesellschaft für Akkreditierung mbH
in compliance with DIN EN ISO/IEC 17025
under the Reg. No. DGA-PL-105/99-22,
FCC Test site registration number 90877 and
Industry Canada Test site registration IC3469A-1



REFERENCES

- [1] **ANSI C63.4-2009** American National Standard for Methods of Measuring of Radio-Noise Emissions from Low-Voltage Electrical and Electronic Equipment in the Range of 9 kHz to 40 GHz.
- [2] **FCC CFR 47 Part 15 (August 2011)** Radio Frequency Devices
- [3] **RSS-210 Issue 8 (December 2010)** Licence-exempt Radio Apparatus (All Frequency Bands): Category I Equipment
- [4] **RSS-Gen Issue 3 (December 2010)** General Requirements and Information for the Certification of Radio Apparatus
- [6] **Publication Number 913591 (March 2007)** Measurement of radiated emissions at the edge of the band for a Part 15 RF Device

TEST RESULT

The requirements of the tests performed as shown in the overview (clause 4) were fulfilled by the equipment under test.

The complete test results are presented in the following.

Test engineer:	Thomas KÜHN <small>Name</small>	 <small>Signature</small>	04 October 2011 <small>Date</small>
Authorized reviewer:	Bernd STEINER <small>Name</small>	 <small>Signature</small>	04 October 2011 <small>Date</small>

RESERVATION

This test report is only valid in its original form.

Any reproduction of its contents in extracts without written permission of the accredited test laboratory PHOENIX TESTLAB GmbH is prohibited.

The test results herein refer only to the tested sample. PHOENIX TESTLAB GmbH is not responsible for any generalizations or conclusions drawn from these test results concerning further samples. Any modification of the tested samples is prohibited and leads to the invalidity of this test report. Each page necessarily contains the PHOENIX TESTLAB Logo and the TEST REPORT NUMBER.

Contents:		Page
1	IDENTIFICATION.....	4
1.1	Applicant.....	4
1.2	Manufacturer	4
1.3	Test laboratory.....	4
1.4	EUT (Equipment Under Test)	5
1.5	Technical data of equipment.....	5
1.6	Dates.....	6
2	OPERATIONAL STATES.....	6
3	ADDITIONAL INFORMATION.....	7
4	OVERVIEW.....	7
5	TEST RESULTS	8
5.1	Calculation of the measurement results	8
5.2	20 dB bandwidth.....	10
5.2.1	Method of measurement (20 dB bandwidth)	10
5.2.2	Test results (20 dB bandwidth)	11
5.3	Band-edge compliance	12
5.3.1	Method of measurement (Band-edge compliance (radiated))	12
5.3.2	Test results (Band-edge compliance (radiated))	13
5.4	Transmission time control	15
5.4.1	Method of measurement (transmission time control).....	15
5.4.2	Test results (transmission time control).....	16
5.5	Radiated emissions	17
5.5.1	Method of measurement (Radiated emissions)	17
5.5.2	Test results (radiated emissions)	24
5.5.2.1	Preliminary radiated emission measurement.....	24
5.5.2.2	Final radiated emission measurement (30 MHz to 1 GHz)	28
5.5.2.3	Final radiated emission measurement (1 GHz to 4 GHz).....	30
6	TEST EQUIPMENT AND ANCILLARIES USED FOR TESTS.....	31
7	REPORT HISTORY	31
8	LIST OF ANNEXES.....	32

1 IDENTIFICATION

1.1 Applicant

Name:	EnOcean GmbH
Address:	Kolpingring 18a 82041 Oberhaching
Country:	Germany
Name for contact purposes:	Mr. Sebastian MEINEKE
Phone:	+ 49 89 67 34 68 9 - 40
Fax:	+ 49 89 67 34 68 9 - 56
eMail Address:	sebastian.meineke@enocean.com
Applicant represented during the test by the following person:	-

1.2 Manufacturer

Name:	EnOcean GmbH
Address:	Kolpingring 18a 82041 Oberhaching
Country:	Germany
Name for contact purposes:	Mr. Sebastian MEINEKE
Phone:	+ 49 89 67 34 68 9 - 40
Fax:	+ 49 89 67 34 68 9 - 56
eMail Address:	sebastian.meineke@enocean.com
Applicant represented during the test by the following person:	-

1.3 Test laboratory

The tests were carried out at: **PHOENIX TESTLAB GmbH**
Königswinkel 10
32825 Blomberg
Germany

accredited by DGA Deutsche Gesellschaft für Akkreditierung mbH in compliance with DIN EN ISO/IEC 17025 under Reg. No. DGA-PL-105/99-22, FCC Test site registration number 90877 and Industry Canada Test site registration IC3469A-1.

1.4 EUT (Equipment Under Test)

Test object: *	315 MHz pushbutton transmitter
Type: *	PTM210 C
FCC ID: *	SZV-PTM211C
IC: *	5713A-PTM211C
Article number: *	S3031-A211
Serial number: *	n/a
Hardware version: *	ver. 2.2
Software version: *	ver. 1.0.0.11
Highest internal frequency: *	26 MHz

1.5 Technical data of equipment

Duty cycle class: *	Manually triggered device				
Channel spacing: *	None (one wideband channel operation only)				
Antenna type: *	Internal wired antenna				
Modulation: *	ASK				
Bit rate of transmitter: *	125 kBit/s				
Supply Voltage: *	$U_{Nom} =$	---	$U_{Min} =$	3.0 V DC	$U_{Max} =$ 15.0 V DC
Power Supply:	3 V DC to 15 V DC by built-in electrodynamic power generator				
Temperature range: *	-25 °C to +65 °C				
Ancillaries to be tested with: *	none				

* declared by the applicant.

The following external I/O cables were used:

Identification	Connector		Length
	EUT	Ancillary	
-	No cables were connectable to the EUT		-
-			-
-			-

*: Length during the test if no other specified.

1.6 Dates

Date of receipt of test sample:	31 August 2011
Start of test:	01 September 2011
End of test:	20 September 2011

2 OPERATIONAL STATES

The EUT is intended to be used for building automation purposes. Pressing its button will activate the transmitter.

Because the transmitter of the EUT will transmit only three telegrams after pressing and releasing the button, all measurements were carried out with a modified sample, which transmits continuously with normal modulation. Furthermore this sample was supplied by a 3 V DC lithium battery type CR 2032. This sample was marked with "9". Pre tests have shown that there was no measurable difference in amplitude of the output signal if the EUT either is supplied by the in-build power generator or the external lithium cell. The measurements for calculating the duty cycle factor and the bandwidth measurements were carried out with an unmodified sample, which was marked with "5".

All measurements were carried out with the EUT in its normal operation position.

Physical boundary of the EUT:

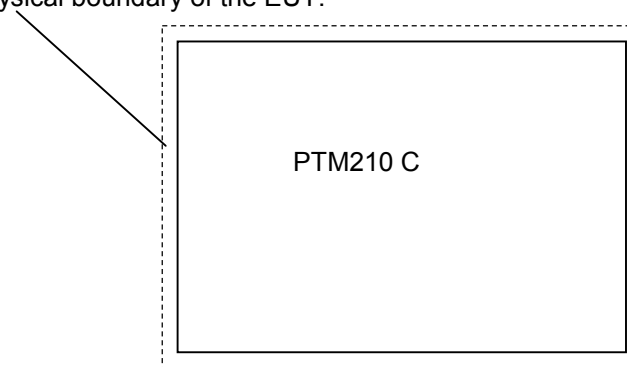

3 ADDITIONAL INFORMATION

During the tests the EUT was not labelled as required by FCC / IC.

4 OVERVIEW

Application	Frequency range [MHz]	FCC 47 CFR Part 15 section [2]	RSS 210, Issue 8 [3] or RSS-Gen, Issue 3 [4]	Status	Refer page
Occupied bandwidth	315	15.231 (c)	A1.1.3 [3]	Passed	10 et seq. and Annex D
Transmission time control	315	15.231 (a) (1)	A1.1.1 [3]	Passed	15 et seq.
Radiated emissions	0.009 – 3,500	15.231 (b) 15.205 (a) 15.209 (a)	2.5 [3] A1.1 [3] 7.2 [4]	Passed	17 et seq.
Conducted emissions on supply line	0.15 - 30	15.207 (a)	7.2.4 [4]	Not applicable*	-

* EUT is powered by an internal power supply only.

5 TEST RESULTS

5.1 Calculation of the measurement results

Because of a single transmission all measurements were carried out with a peak detector and the average value is calculated over the real pulse train as required in Part 15.35.

To calculate the average value a timing of the emission was measured. A detail view to the transmission pulse was recorded and the total transmitter on time was calculated.

112808_8.wmf: Complete pulse train:

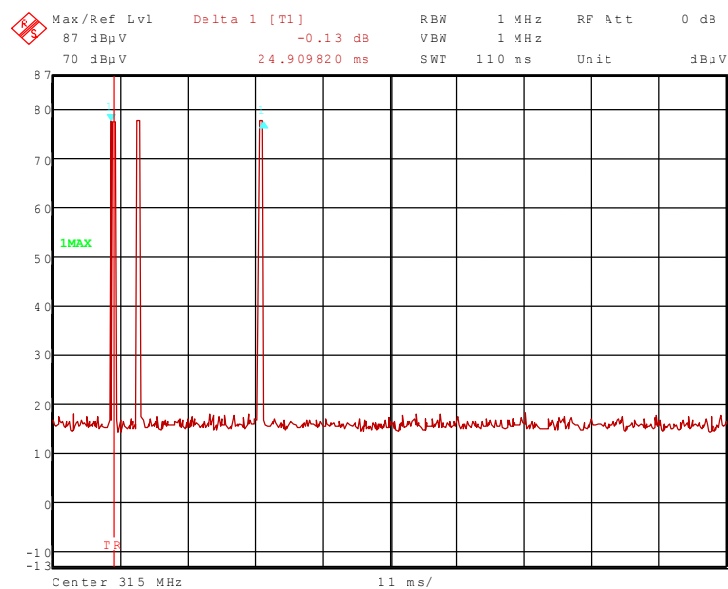

The complete pulse train consists of 3 identical sub pulse trains with a total length of 24.910 ms.

Because the transmitter of the EUT will transmit only three telegrams after pressing the button and three telegrams after releasing the button unrespectable of how long the button is pressed. So within a 100 ms time period only three telegrams were transmitted

The measurement was carried out several times. The documented time represents a mean time in respect to the duty cycle.

112808_9.wmf: total view to longest pulse:

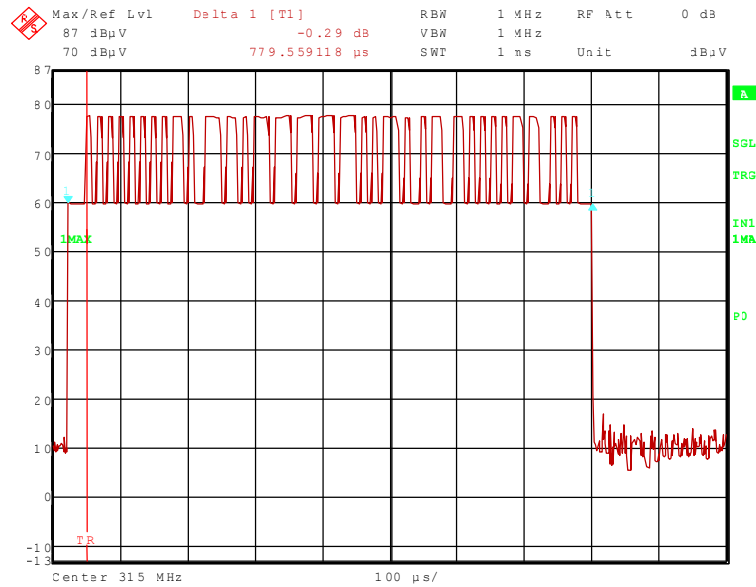

Total length of sub pulse train = 779.559 µs.

Duty cycle correction factor according to 15.35c:

$$F \text{ [dB]} = 20 * \log (3 \times 779.559 \mu\text{s} / 24.910 \text{ ms}) = -20.5 \text{ dB}$$

So the measured peak values were calculated with 20 dB down into average values.

TEST EQUIPMENT USED FOR THE TEST:
24, 31

5.2 20 dB bandwidth

5.2.1 Method of measurement (20 dB bandwidth)

The calibration of the spectrum analyser has to be checked with the help of a known signal from a signal generator. The EUT has to be connected to the spectrum analyser via a low loss cable. If the EUT is not equipped with an antenna connector, a temporary antenna connector has to be installed or a test fixture has to be used. The EUT has to be switched on, the transmitter shall work with its maximum data rate.

The following spectrum analyser settings shall be used:

- Span: App. 2 to 3 times the 20 dB bandwidth, centred on the actual channel.
- Resolution bandwidth: Between 1 % to 5 % of the required bandwidth, if no requirements were made, the following minimum values shall be used:
From 9 kHz to 30 MHz: $RBW_{min} = 1 \text{ kHz}$;
from 30 MHz to 1000: MHz $RBW_{min} = 10 \text{ kHz}$;
and from 1000 MHz to 40 GHz: $RBW_{min} = 100 \text{ kHz}$.
- Video bandwidth: \geq the resolution bandwidth.
- Sweep: Auto.
- Detector function: peak.
- Trace mode: Max hold.

After trace stabilisation the marker shall be set on the signal peak. The first display line has to be set on this value. The second display line has to be set 20 dB below the first line (or the peak marker). The frequency lines shall be set on the intersection points between the second display line and the measured curve.

The measurement will be performed at the upper, the lower end and the middle of the assigned frequency band.

Test set-up:

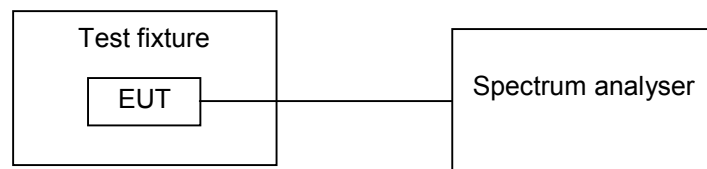

5.2.2 Test results (20 dB bandwidth)

Ambient temperature	21 °C
---------------------	-------

Relative humidity	43 %
-------------------	------

112808_10.wmf: 20 dB Bandwidth:

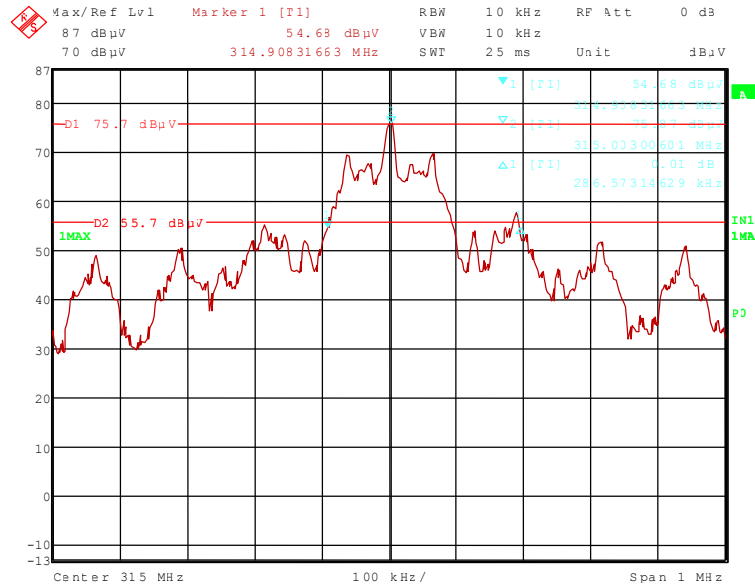

Lower frequency	Upper frequency	20 dB bandwidth	LIMIT (0.25 % of the center frequency)
314.908317	315.194890	286.573	787.500 kHz
Measurement uncertainty		+0.66 dB / -0.72 dB	

Test: Passed

TEST EQUIPMENT USED FOR THE TEST:
24, 31

5.3 Band-edge compliance

5.3.1 Method of measurement (Band-edge compliance (radiated))

The same test set-up as used for the final radiated emission measurement shall be used (refer also subclause 5.5.1 of this test report).

The following spectrum analyser settings shall be used:

- Span: Wide enough to capture the peak level of the emission on the channel closest to the band-edge, as well as any modulation products, which fall outside the assigned frequency band.
- Resolution bandwidth: 100 kHz.
- Video bandwidth: \geq the resolution bandwidth.
- Sweep: Auto.
- Detector function: Peak.
- Trace mode: Max hold.

After trace stabilisation the marker shall be set on the signal peak. The first display line has to be set on this value. The second display line has to be set 20 dB below the first line (or the peak marker). The frequency line shall be set on the edge of the assigned frequency band. Set the second marker on the emission at the band-edge, or on the highest modulation product outside of the band, if this level is higher than that at the band-edge. This frequency shall be measured with the EMI receiver as described in subclause 5.5.1 of this test report, but 100 kHz resolution bandwidth shall be used.

The measurement will be performed at the upper end of the assigned frequency band if applicable.

5.3.2 Test results (Band-edge compliance (radiated))

Ambient temperature	21 °C
---------------------	-------

Relative humidity	45 %
-------------------	------

112808_7.wmf: Band edge compliance (radiated):

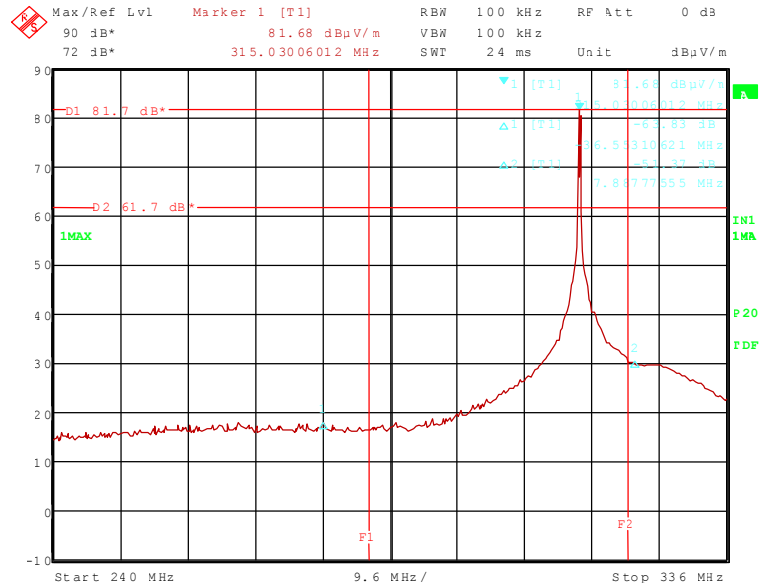

The plot on the page before shows the radiated band-edge compliance for the upper and lower band edge. The display line 1 (D1) in the plot represents the highest level within the assigned frequency band. The display line 2 (D2) represents the 20 dB offset to this highest level and shows the compliance with FCC 47 CFR Part 15.231 (b). The frequency lines 1 (F1) and 2 (F2) are showing the edges of the assigned or restricted frequency bands.

Band edge compliance (lower band edge)											
Result measured with the peak detector and corrected to average:											
Frequency MHz	Corr. Value dBµV/m	Limit dBµV/m	Margin dB	Readings dBµV	Correction factor dBµV	Antenna factor 1/m	Cable loss dB	Azim.	Height cm	Pol.	Restr. Band
315.000	71.8	-	-	76.8	-20.0	13.1	1.9	290.0	100.0	Vert.	carrier
276.168	27.3	46.0	18.7	13.0	- *	12.4	1.9	290.0	100.0	Vert..	Yes
Measurement uncertainty								+2.2 dB / -3.6 dB			

*:No duty cycle was observed at this frequency, so no duty cycle correction factor was used.

Band edge compliance (upper band edge)											
Result measured with the peak detector and corrected to average:											
Frequency MHz	Corr. Value dBµV/m	Limit dBµV/m	Margin dB	Readings dBµV	Correction factor dBµV	Antenna factor 1/m	Cable loss dB	Azim.	Height cm	Pol.	Restr. Band
315.000	71.8	-	-	76.8	-20.0	13.1	1.9	290.0	100.0	Vert.	carrier
325.034	20.8	46.0	25.2	25.4	-20.0	13.5	1.9	290.0	100.0	Vert.	Yes
Measurement uncertainty								+2.2 dB / -3.6 dB			

Test: Passed

TEST EQUIPMENT USED FOR THE TEST:
29, 31 – 35, 142

5.4 Transmission time control

5.4.1 Method of measurement (transmission time control)

The calibration of the spectrum analyser has to be checked with the help of a known signal from a signal generator. The EUT has to be connected to the spectrum analyser via a low loss cable. If the EUT is not equipped with an antenna connector, a temporary antenna connector has to be installed or a test fixture has to be used. The EUT has to be switched on, the transmitter shall work with its maximum data rate.

The following spectrum analyser settings shall be used:

- Span: = 0 Hz.
- Resolution bandwidth: 1 MHz.
- Video bandwidth: \geq the resolution bandwidth.
- Sweep: Single sweep with at least 5 seconds.
- Detector function: peak.
- Trace mode: Max hold.

The frequency line shall be set a point, were the transmitter will be released. The sweep shall start, when the transmitter started to operate, The transmitter shall released when the trace crosses the frequency line. One marker shall be set to the point of the frequency line, a delta marker to the time, were the transmitter stopped transmission.

Test set-up:

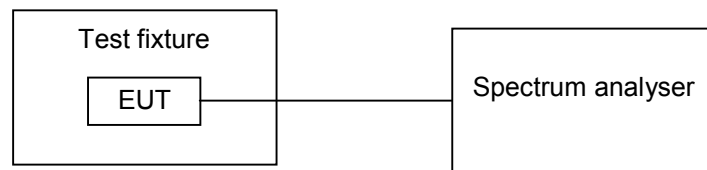

5.4.2 Test results (transmission time control)

Ambient temperature	21 °C
---------------------	-------

Relative humidity	43 %
-------------------	------

112808_11.wmf: Transmitter release time:

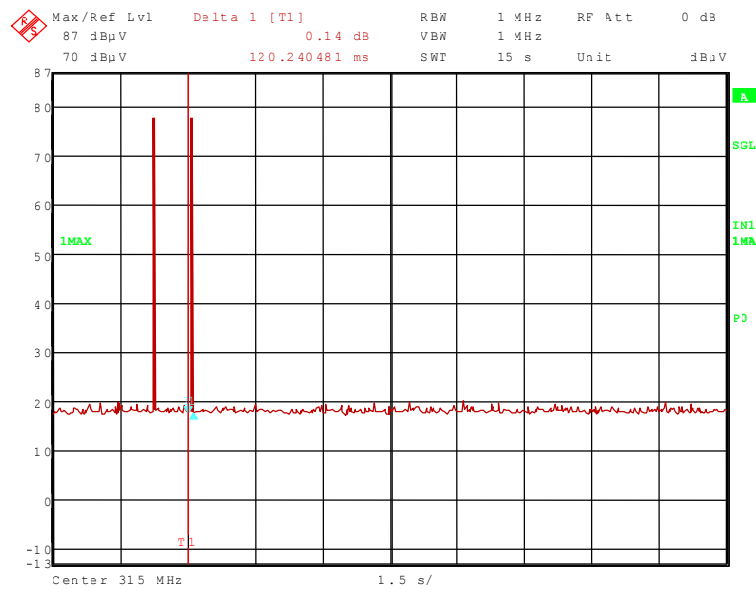

Transmitter release time	LIMIT
120.240 ms	5 s
Measurement uncertainty	<10 ⁻⁷

Test: Passed

TEST EQUIPMENT USED FOR THE TEST:
24, 31

5.5 Radiated emissions

5.5.1 Method of measurement (Radiated emissions)

The radiated emission measurement is subdivided into five stages.

- A preliminary measurement carried out in a fully anechoic chamber with a fixed antenna height in the frequency range 9 kHz to 1 GHz.
- A final measurement carried out on an outdoor test site without reflecting ground plane and a fixed antenna height in the frequency range 9 kHz to 30 MHz.
- A final measurement carried out on an open area test site with reflecting ground plane and various antenna heights in the frequency range 30 MHz to 1 GHz.
- A preliminary measurement carried out in a fully anechoic chamber with a variable antenna distance and height in the frequency range 1 GHz to 25 / 40 GHz.
- A final measurement carried out in a fully anechoic chamber with a fixed antenna height in the frequency range 1 GHz to 25 / 40 GHz.

Preliminary measurement (9 kHz to 30 MHz):

In the first stage a preliminary measurement will be performed in a shielded room with a measuring distance of

3 meters. Tabletop devices will set up on a non-conducting support with a size of 1 m by 1.5 m and a height of 80 cm. Floor-standing devices will be placed directly on the turntable/ground plane. The set up of the Equipment under test will be in accordance to ANSI C63.4-2009 [1].

The frequency range 9 kHz to 30 MHz will be monitored with a spectrum analyser while the system and its cables will be manipulated to find out the configuration with the maximum emission levels if applicable. The EMI Receiver will be set to MAX Hold mode. The EUT and the measuring antenna will be rotated around their vertical axis to found the maximum emissions.

The resolution bandwidth of the spectrum analyser will be set to the following values:

Frequency range	Resolution bandwidth
9 kHz to 150 kHz	200 Hz
150 kHz to 30 MHz	10 kHz

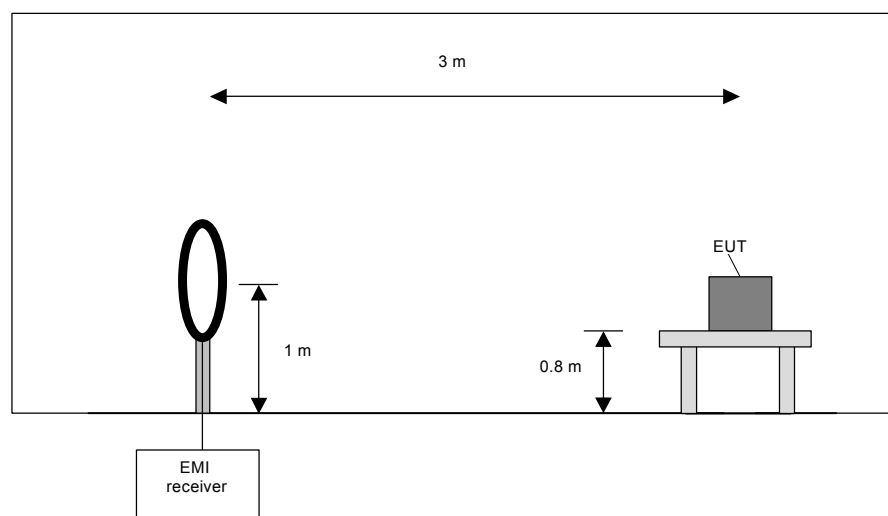

Preliminary measurement procedure:

Prescans were performed in the frequency range 9 kHz to 150 kHz and 150 kHz to 30 MHz.

The following procedure will be used:

- 1) Monitor the frequency range at horizontal polarisation and a EUT azimuth of 0 °.
- 2) Manipulate the system cables within the range to produce the maximum level of emission.
- 3) Rotate the EUT by 360 ° to maximize the detected signals.
- 4) Make a hardcopy of the spectrum.
- 5) Measure the frequencies of highest detected emission with a lower span and resolution bandwidth to increase the accuracy and note the frequency value.
- 6) Repeat steps 1) to 5) with the other orthogonal axes of the EUT (because of EUT is a module and might be used in a handheld equipment application).
- 7) Rotate the measuring antenna and repeat steps 1) to 5).

Final measurement (9 kHz to 30 MHz):

In the second stage a final measurement will be performed on an open area test site with no conducting ground plane in measuring distances of 3 m, 10 m and 30 m. In the case where larger measuring distances is required the results will be extrapolated based on the values measured on the closer distances according to Section 15.31 (f) (2) [2]. The final measurement will be performed with a EMI Receiver set to Quasi Peak detector except for the frequency bands 9 kHz to 90 kHz and 110 kHz to 490 kHz where an average detector will be used according Section 15.209 (d) [2].

On the during the preliminary measurement detected frequencies the final measurement will be performed while rotating the EUT and the measuring antenna in the range of 0 ° to 360 ° around their vertical axis until the maximum value is found.

The resolution bandwidth of the EMI Receiver will be set to the following values:

Frequency range	Resolution bandwidth
9 kHz to 150 kHz	200 Hz
150 kHz to 30 MHz	9 kHz

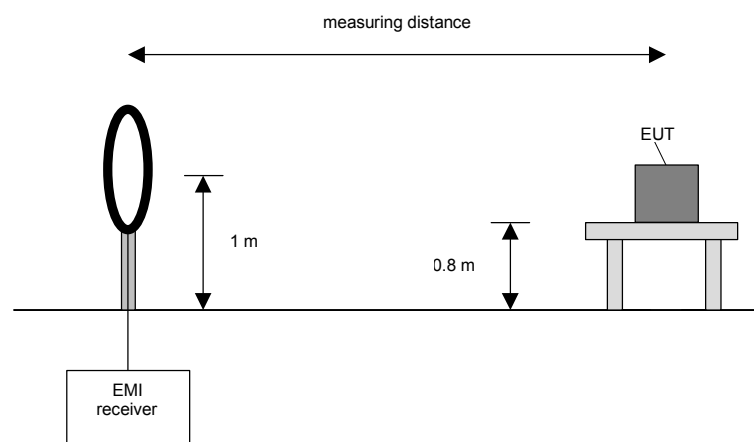

Final measurement procedure:

The following procedure will be used:

- 1) Monitor the frequency range with the measuring antenna at vertical orientation parallel to the EUT at an azimuth of 0 °.
- 2) Rotate the EUT by 360 ° to maximize the detected signals and note the azimuth and orientation.
- 3) Rotate the measuring antenna to find the maximum and note the value.
- 4) Rotate the measuring antenna and repeat steps 1) to 3) until the maximum value is found.
- 5) Repeat steps 1) to 4) with the other orthogonal axes of the EUT (because of EUT is a module and might be used in a handheld equipment application).

Preliminary measurement (30 MHz to 1 GHz)

In the first stage a preliminary measurement will be performed in a fully anechoic chamber with a measuring distance of 3 meter. Tabletop devices will set up on a non-conducting support with a size of 1 m by 1.5 m and a height of 80 cm. Floor-standing devices will be placed directly on the turntable/ground plane. The set up of the Equipment under test will be in accordance to ANSI C63.4-2009 [1].

The frequency range 30 MHz to 1 GHz will be measured with an EMI Receiver set to MAX Hold mode and a resolution bandwidth of 100 kHz. The measurement will be performed in horizontal and vertical polarisation of the measuring antenna and while rotating the EUT in its vertical axis in the range of 0 ° to 360 °.

The resolution bandwidth of the EMI Receiver will be set to the following values:

Frequency range	Resolution bandwidth
30 MHz to 230 MHz	100 kHz
230 MHz to 1 GHz	100 kHz

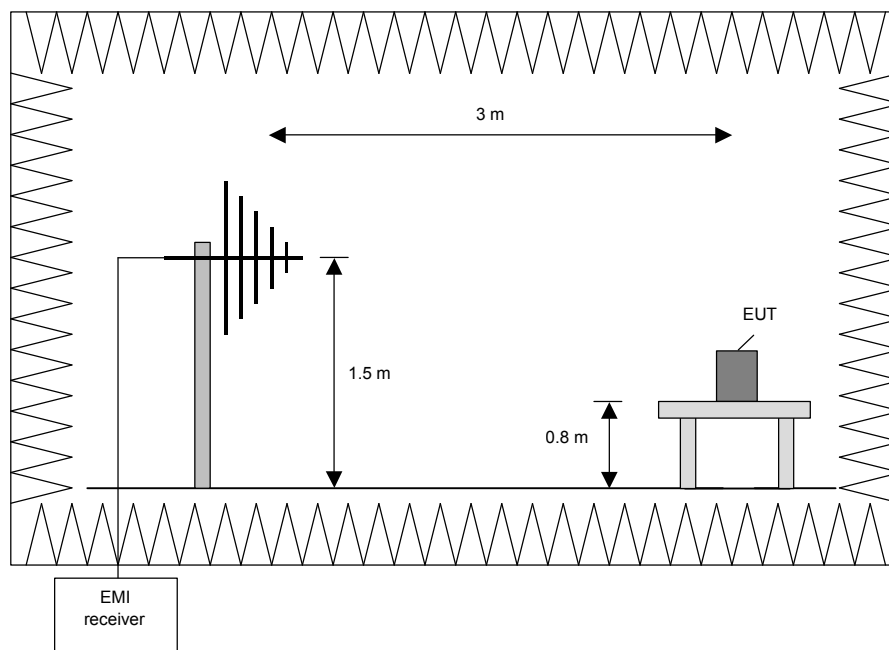

Procedure preliminary measurement:

Prescans were performed in the frequency range 30 MHz to 230 MHz and 230 MHz to 1 GHz.

The following procedure will be used:

1. Monitor the frequency range at horizontal polarisation and a EUT azimuth of 0 °.
2. Manipulate the system cables within the range to produce the maximum level of emission.
3. Rotate the EUT by 360 ° to maximize the detected signals.
4. Make a hardcopy of the spectrum.
5. Measure the frequency of the detected emissions with a lower span and resolution bandwidth to increase the accuracy and note the frequency value.
6. Repeat 1) to 4) with the other orthogonal axes of the EUT (because of EUT is a module and might be used in a handheld equipment application).
7. Repeat 1) to 5) with the vertical polarisation of the measuring antenna.

Final measurement (30 MHz to 1 GHz)

A final measurement on an open area test site will be performed on selected frequencies found in the preliminary measurement. During this test the EUT will be rotated in the range of 0 ° to 360 °, the measuring antenna will be set to horizontal and vertical polarisation and raised and lowered in the range from 1 m to 4 m to find the maximum level of emissions.

The resolution bandwidth of the EMI Receiver will be set to the following values:

Frequency range	Resolution bandwidth
30 MHz to 1 GHz	120 kHz

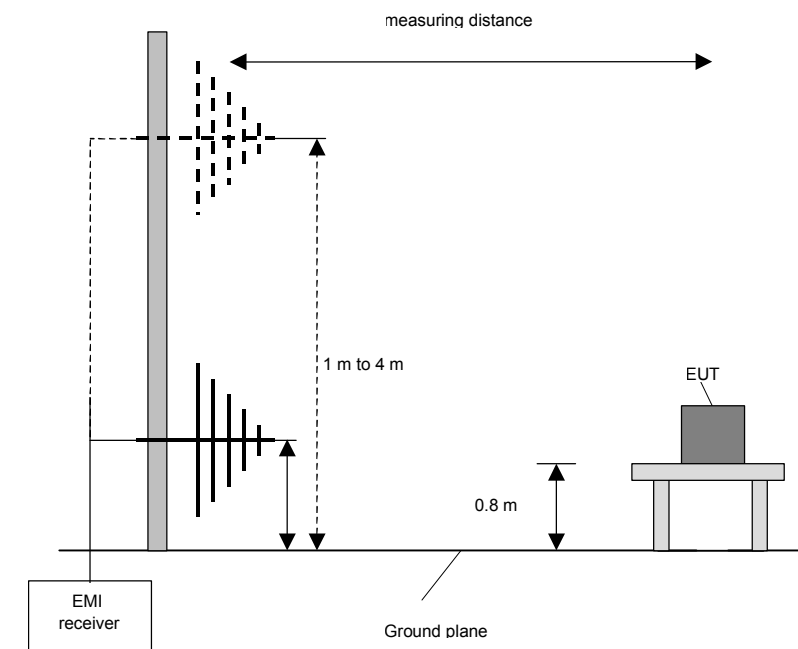

Procedure final measurement:

The following procedure will be used:

- 1) Measure on the selected frequencies at an antenna height of 1 m and a EUT azimuth of 23 °.
- 2) Move the antenna from 1 m to 4 m and note the maximum value at each frequency.
- 3) Rotate the EUT by 45 ° and repeat 2) until an azimuth of 337 ° is reached.
- 4) Repeat 1) to 3) for the other orthogonal antenna polarization.
- 5) Move the antenna and the turntable to the position where the maximum value is detected.
- 6) Measure while moving the antenna slowly +/- 1 m.
- 7) Set the antenna to the position where the maximum value is found.
- 8) Measure while moving the turntable +/- 45 °.
- 9) Set the turntable to the azimuth where the maximum value is found.
- 10) Measure with Final detector (QP and AV) and note the value.
- 11) Repeat 5) to 10) for each frequency.
- 12) Repeat 1) to 11) for each orthogonal axes of the EUT (because of EUT is a module and might be used in a handheld equipment application).

Preliminary and final measurement (1 GHz to 40 GHz)

This measurement will be performed in a fully anechoic chamber. Tabletop devices will set up on a non-conducting support with a size of 1 m by 1.5 m and a height of 80 cm. Floor-standing devices will be placed directly on the turntable/ground plane. The set up of the Equipment under test will be in accordance to ANSI C63.4-2009 [1].

Preliminary measurement (1 GHz to 40 GHz)

The frequency range will be divided into different sub ranges depending of the frequency range of the used horn antenna. The spectrum analyser set to MAX Hold mode and a resolution bandwidth of 100 kHz. The measurement will be performed in horizontal and vertical polarisation of the measuring antenna, the antenna close to the EUT and while moving the antenna over all sides of the EUT. With the spectrum analyser in CLEAR / WRITE mode the cone of the emission should be found and than the measuring distance will be set to 3 m with the receiving antenna moving in this cone of emission. At this position the final measurement will be carried out.

The resolution bandwidth of the EMI Receiver will be set to the following values:

Frequency range	Resolution bandwidth
1 GHz to 4 GHz	100 kHz
4 GHz to 12 GHz	100 kHz
12 GHz to 18 GHz	100 kHz
18 GHz to 25 / 26.5 GHz	100 kHz
26.5 GHz to 40 GHz	100 kHz

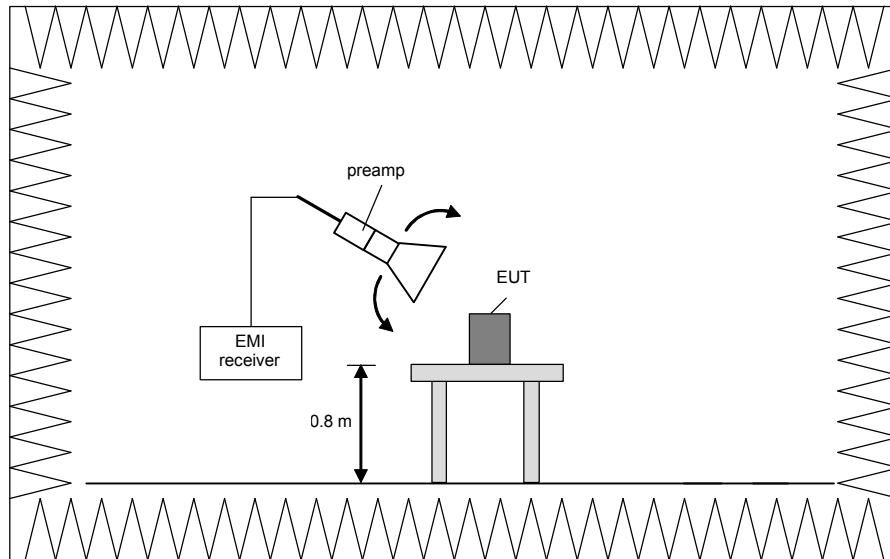

Final measurement (1 GHz to 40 GHz)

The frequency range will be divided into different sub ranges depending of the frequency range of the used horn antenna. The EMI Receiver set to peak and average mode and a resolution bandwidth of 1 MHz. The measurement will be performed in horizontal and vertical polarisation of the measuring antenna and while rotating the EUT in its vertical axis in the range of 0 ° to 360 ° in order to have the antenna inside the cone of radiation.

The resolution bandwidth of the EMI Receiver will be set to the following values:

Frequency range	Resolution bandwidth
1 GHz to 4 GHz	1 MHz
4 GHz to 12 GHz	1 MHz
12 GHz to 18 GHz	1 MHz
18 GHz to 25 / 26.5 GHz	1 MHz
26.5 GHz to 40 GHz	1 MHz

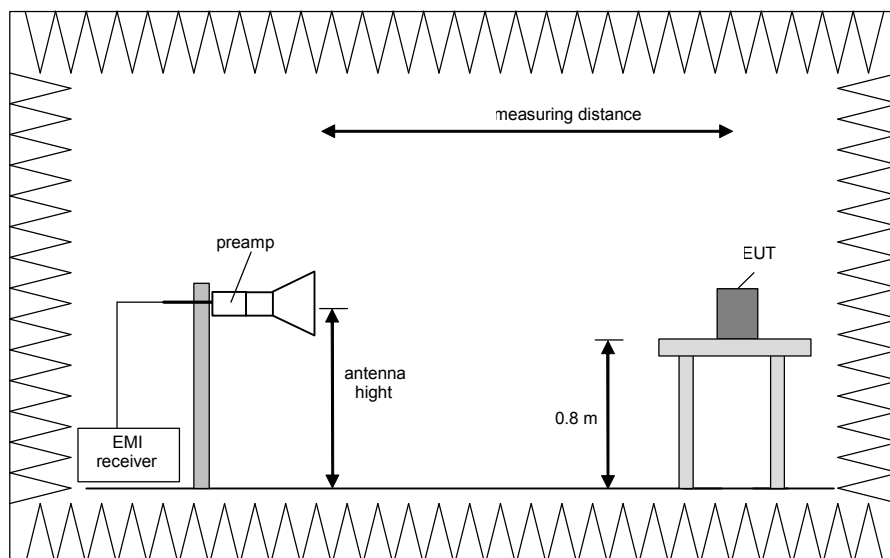

Procedure of measurement:

The measurements were performed in the frequency ranges 1 GHz to 4 GHz, 4 GHz to 12 GHz, 12 GHz to 18 GHz, 18 GHz to 25 /26.5 GHz and 26.5 GHz to 40 GHz.

The following procedure will be used:

- 1) Monitor the frequency range at horizontal polarisation and move the antenna over all sides of the EUT (if necessary move the EUT to another orthogonal axis).
- 2) Change the antenna polarisation and repeat 1) with vertical polarisation.
- 3) Make a hardcopy of the spectrum.
- 4) Measure the frequency of the detected emissions with a lower span and resolution bandwidth to increase the accuracy and note the frequency value.
- 5) Change the analyser mode to Clear / Write and found the cone of emission.
- 6) Rotate and move the EUT, so that the measuring distance can be enlarged to 3 m and the antenna will be still inside the cone of emission.
- 7) Measure the level of the detected frequency with the correct resolution bandwidth, with the antenna polarisation and azimuth and the peak and average detector, which causes the maximum emission.
- 8) Repeat steps 1) to 7) for the next antenna spot if the EUT is larger than the antenna beamwidth.

Step 1) to 6) are defined as preliminary measurement.

5.5.2 Test results (radiated emissions)

5.5.2.1 Preliminary radiated emission measurement

Ambient temperature	21 °C	Relative humidity	45 %
---------------------	-------	-------------------	------

- Position of EUT: The EUT was set-up on a non-conducting table of a height of 0.8 m. The distance between EUT and antenna was 3 m.
- Cable guide: No cables were connectable to the EUT. For further information of the EUT set-up refer to the pictures in annex A of this test report.
- Test record: During the test, the EUT transmits continuously with normal modulation. All results are shown in the following.
- Supply voltage: The EUT was supplied by a new battery.

112808_4: Spurious emissions from 9 kHz to 150 kHz:

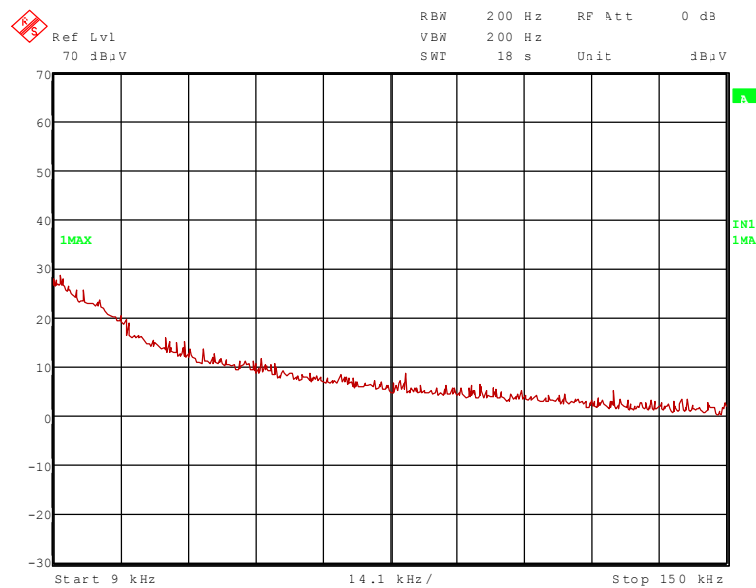

112808_5: Spurious emissions from 150 kHz to 1 MHz:

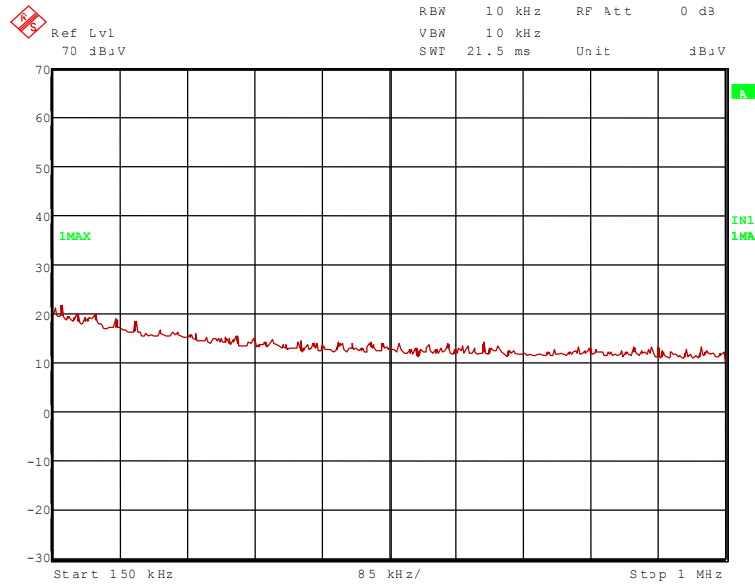

112808_6: Spurious emissions from 1 MHz to 30 MHz:

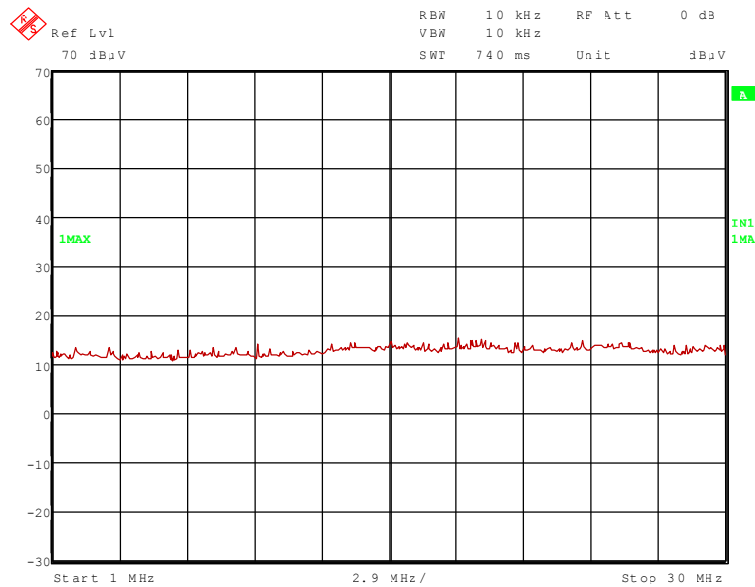

No significant frequencies above the noise floor of the system were found during the preliminary radiated emission test, so no measurements were carried out on the outdoor test site.

112808_3: Spurious emissions from 1 GHz to 3.5 GHz:

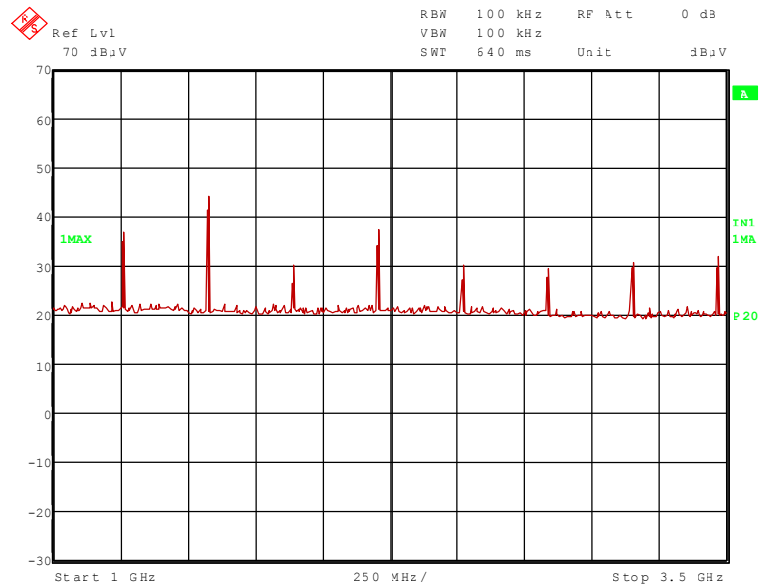

The following frequencies were found inside the restricted bands during the preliminary radiated emission test:

- 1.575 GHz, 2.205 GHz and 2.835 GHz.

The following frequencies were found outside the restricted bands during the preliminary radiated emission test:

- 1.260 GHz, 1.890 GHz, 2.520 GHz, 3.150 GHz and 3.465 GHz.

At the frequency has to be performed a final measurement. The result is presented in the following.

TEST EQUIPMENT USED THE TEST:

29, 31 – 35, 36, 73, 133, 142, 143, 156

5.5.2.2 Final radiated emission measurement (30 MHz to 1 GHz)

Ambient temperature	20 °C	Relative humidity	40 %
---------------------	-------	-------------------	------

- Position of EUT: The EUT was set-up on a non-conducting table of a height of 0.8 m. The distance between EUT and antenna was 3 m.
- Cable guide: No cables were connectable to the EUT. For further information of the EUT set-up refer to the pictures in annex A of this test report.
- Test record: During the test, the EUT transmits continuously with normal modulation. All results are shown in the following.
- Supply voltage: The EUT was supplied by a new battery.
- Test results: The test results were calculated with the following formula:

$$\text{Result [dB}\mu\text{V/m]} = \text{reading [dB}\mu\text{V]} + \text{cable loss [dB]} + \text{antenna factor [dB/m]} + \text{duty cycle correction factor [dB]}$$

The measured points and the limit line in the following diagram refer to the standard measurement of the emitted interference in compliance with the above-mentioned standard. The measured points marked with x are the measured results of the standard final measurement on the open area test site but without consideration of the duty cycle correction factor.

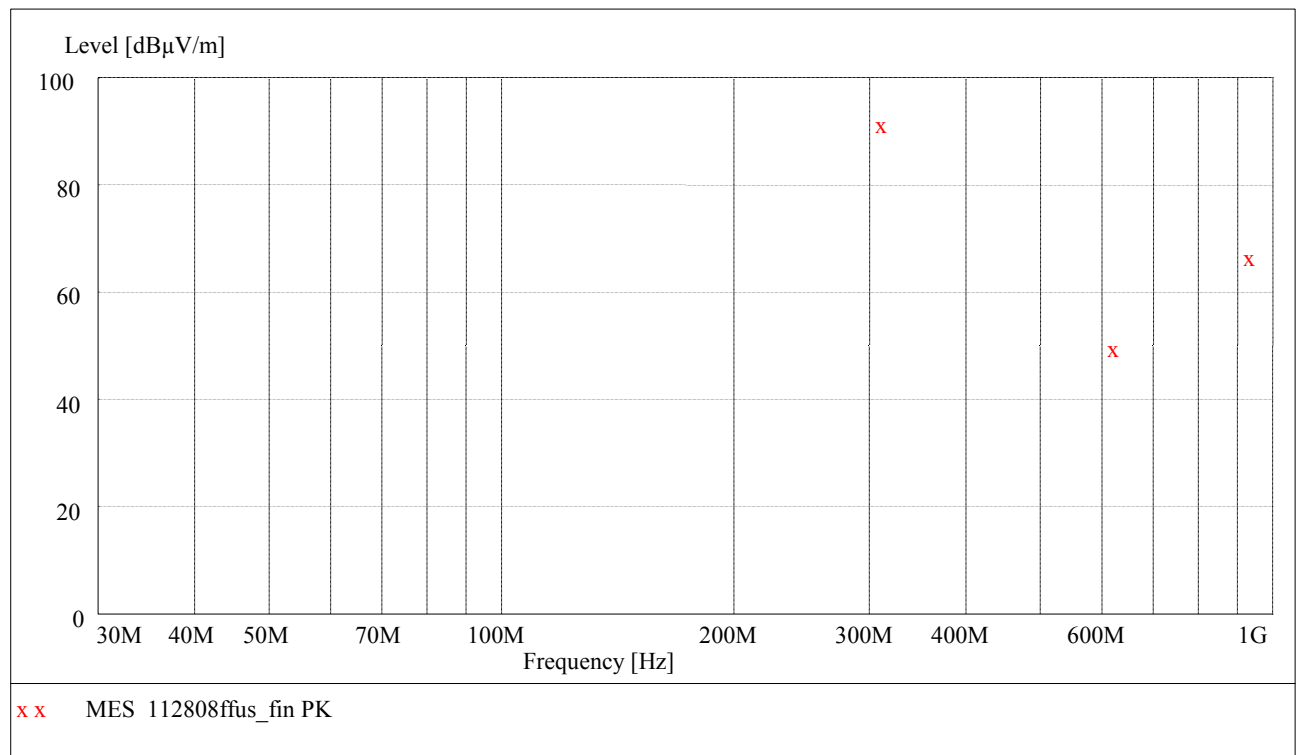

Data record name: 112808ffus

The results of the standard final measurement on the open area test site are indicated in the table below. The limits as well as the measured results (levels) refer to the above-mentioned standard while taking account of the specified requirements for a 3 m measuring distance.

The measurement time with the quasi-peak measuring detector is 1 second.

Result measured with the peak detector and corrected to average:
(These values are marked in the above diagram by x)

Spurious emissions outside restricted bands										
Frequency MHz	Result dBµV/m	Limit dBµV/m	Margin dB	Readings dBµV	Correction factor dB	Antenna factor dB/m	Cable loss dB	Height cm	Azimuth deg	Pol.
315.000 *	71.8	75.6	3.8	76.8	-20.0	13.1	1.9	100.0	292.0	Vert.
630.000	30.1	54.3	24.2	27.5	-20.0	19.6	2.8	150.0	292.0	Vert.
945.000	47.3	54.3	7.3	40.0	-20.0	23.9	3.4	302.0	110.0	Vert.
Spurious emissions in restricted bands										
Frequency MHz	Result dBµV/m	Limit dBµV/m	Margin dB	Readings dBµV	Correction factor dB	Antenna factor dB/m	Cable loss dB	Height cm	Azimuth deg	Pol.
-	-	-	-	-	-	-	-	-	-	-
Measurement uncertainty						+2.2 dB / -3.6 dB				

*: Wanted signal, no spurious

Test: Passed

TEST EQUIPMENT USED FOR THE TEST:

14 – 20

5.5.2.3 Final radiated emission measurement (1 GHz to 4 GHz)

Ambient temperature	21 °C	Relative humidity	45 %
---------------------	-------	-------------------	------

Position of EUT: The EUT was set-up on a non-conducting table of a height of 0.8 m. The distance between EUT and antenna was 3 m.

Cable guide: No cables were connectable to the EUT. For further information of the EUT set-up refer to the pictures in annex A of this test report.

Test record: During the test, the EUT transmits continuously with normal modulation. All results are shown in the following. The test results were calculated with the following formula:

$$\text{Result [dB}\mu\text{V/m]} = \text{reading [dB}\mu\text{V]} + \text{cable loss [dB]} + \text{antenna factor [dB/m]} - \text{Preamp [dB]} + \text{duty cycle correction factor [dB]}$$

Supply voltage: The EUT was supplied by a new battery.

Resolution bandwidth: For all measurements a resolution bandwidth of 1 MHz was used.

Result measured with the peak detector and corrected to average:

Frequency GHz	Corr. value dB μ V/m	Limit dB μ V/m	Margin dB	Readings dB μ V	Correction factor	Antenna factor 1/m	Preamp dB	Cable loss dB	Height cm	Pol.	Restr. Band
1.260	22.8	54.3	31.5	41.7	-20.0	24.9	26.5	2.7	150	Hor.	No
1.575	28.3	54.0	25.7	46.5	-20.0	25.3	26.5	3.0	150	Vert.	Yes
1.890	20.8	54.3	33.5	36.6	-20.0	27.3	26.5	3.4	150	Hor.	No
2.205	25.1	54.0	28.9	40.3	-20.0	27.7	26.5	3.6	150	Vert.	Yes
2.520	22.1	54.3	32.2	36.1	-20.0	28.6	26.4	3.8	150	Vert.	No
2.835	22.0	54.0	32.0	35.2	-20.0	29.2	26.4	4.0	150	Hor.	Yes
3.150	25.1	54.3	29.2	36.5	-20.0	30.7	26.4	4.3	150	Hor.	No
3.465	25.9	54.3	28.4	36.7	-20.0	31.1	26.3	4.4	150	Hor.	No
Measurement uncertainty							+2.2 dB / -3.6 dB				

Test: Passed

TEST EQUIPMENT USED FOR THE TEST:

29, 31 – 34, 36, 73, 143, 156

6 TEST EQUIPMENT AND ANCILLARIES USED FOR TESTS

No.	Test equipment	Type	Manufacturer	Serial No.	PM. No.	Cal. Date	Cal. due
6	Spectrum analyser	FSU	Rohde & Schwarz	200125	480956	04/15/2010	04/2012
14	Open area test site	-	Phoenix Test-Lab	-	480085	Weekly verification (system cal.)	
15	Measuring receiver	ESIB7	Rohde & Schwarz	100304	480521	03/15/2010	03/2012
16	Controller	HD100	Deisel	100/670	480139	-	-
17	Turntable	DS420HE	Deisel	420/620/80	480087	-	-
18	Antenna support	AS615P	Deisel	615/310	480086	-	-
19	Antenna	CBL6111 D	Chase	22921	480674	08/27/2011	08/2014
20	EMI Software	ES-K1	Rohde & Schwarz	-	480111	-	-
24	Loop Antenna $\varnothing = 225$ mm	-	Phoenix Test-Lab	-	410085	Six-month verification (system cal.)	
29	Fully anechoic chamber M20	-	Albatross Projects	B83107-E2439-T232	480303	Weekly verification (system cal.)	
31	Measuring receiver	ESI 40	Rohde & Schwarz	100064	480355	03/17/2010	03/2012
32	Controller	MCU	Maturo	MCU/043/971107	480832	-	-
33	Turntable	DS420HE	Deisel	420/620/80	480315	-	-
34	Antenna support	AS615P	Deisel	615/310	480187	-	-
35	Antenna	CBL6112 B	Chase	2917	480447	09/28/2010	09/2013
36	Horn Antenna	3115 A	EMCO	9609-4918	480183	11/04/2008	11/2011
73	High Pass Filter	WHJS1000 C11/60EF	Wainwright Instruments GmbH	1	480413	Weekly verification (system cal.)	
133	Loop antenna	HFH2-Z2	Rohde & Schwarz	832609/014	480059	03/10/2010	03/2012
142	RF-cable No. 36	Sucoflex 106B	Huber + Suhner	-	480865	Weekly verification (system cal.)	
143	RF-cable No. 30	RTK 081	Rosenberger	-	410141	Weekly verification (system cal.)	
156	Preamplifier	JS3-00101200-23-5A	Miteq	681851	480337	Weekly verification (system cal.)	

7 REPORT HISTORY

Report Number	Date	Comment
F112808E1	04 October 2011	Document created
-	-	-
-	-	-

8 LIST OF ANNEXES

ANNEX A	TEST SETUP PHOTOGRAPHS	5 pages
	<p>112808_b.JPG: PTM210 C, test setup fully anechoic chamber 112808_d.JPG: PTM210 C, test setup fully anechoic chamber 112808_a.JPG: PTM210 C, test setup fully anechoic chamber 112808_c.JPG: PTM210 C, test setup fully anechoic chamber 112808_j.JPG: PTM210 C, test setup open area test site</p>	
ANNEX B	INTERNAL PHOTOGRAPHS	7 pages
	<p>112808_3.JPG: PTM210 C, internal (top) view 112808_4.JPG: PTM210 C, internal (bottom) view, unmodified sample 112808_11.JPG: PTM210 C, internal (bottom) view, modified sample 112808_5.JPG: PTM210 C, internal view 112808_12.JPG: PTM210 C, internal view, modified sample 112808_6.JPG: PTM210 C, PCB, top view 112808_10.JPG: PTM210 C, PCB, bottom view</p>	
ANNEX C	EXTERNAL PHOTOGRAPHS	6 pages
	<p>112808_fr.JPG: PTM210 C, front view 112808_re.JPG: PTM210 C, rear view 112808_le.JPG: PTM210 C, lefthand side view 112808_re.JPG: PTM210 C, righthand side view 112808_tp.JPG: PTM210 C, top view 112808_bo.JPG: PTM210 C, bottom view</p>	
ANNEX D	ADDITIONAL RESULTS FOR INDUSTRY CANADA	2 Pages