User Manual
For
Mobile Digital Video Recorder

Notice

The information in this manual was current when published. The manufacturer reserves the right to revise and improve its products. All specifications are therefore subject to change without any notice.

The purpose of this manual is to kindly aid the user for the operation for our MDVR. The user should have a basic understanding of computer operation and basic knowledge of how to connect peripherals and make some settings.

Guarantee & Warnings

1) Electrical Apparatus Safety

All installation and operation should comply with local electrical safety norms.

2) Transportation

In the process of transportation, storage and installation, please avoid heavy stress, violent vibration, impact and water splashing.

3) Installation

Install the equipment in accordance with the requirements, handle carefully. Do not heavily press the equipment before the MDVR installation is finished.

4) Requirements on Engineers & Technicians

All the work of checking and maintenance should be done by qualified technicians and engineers. We do not undertake any responsibility caused by unauthorized modifications.

5) Requirements on Environment

The equipment should be installed and stored in a cool and dry place, away from direct sunlight, flammable or explosive substances, etc. Keep gaps not less than 3cm around the device to facilitate ventilation for cooling.

6) Accessories

Make sure to use accessories from the manufacturer recommended in the attachment.

Insulate circuit ground and metal shell for all the peripherals.

Before installation, please open the package and ensure that all parts are included.

If there are any problems, please contact us as soon as possible.

1. PRODUCT CHARACTERISTICS

1.1. OVERVIEW

24CH NVR is a functional Digital Video Recorder specially designed for vehicle video surveillance and remote monitoring. It has a high-speed processor and embedded operating system, combining with the most advanced H.264/H.265 video compression / decompression technology, 3G/4G network, GPS positioning technology, as well as WIFI. It supports not only video recording in 1080P, 720P, AHD, D1, HD1 and CIF formats, but also vehicle travel information recording and wireless data upload. With center software it also achieves alarm linkage central monitoring, remote management and playback analysis. It is easy to use with simple design, multi-functions, HDD + SD card , superior anti-vibration, flexible installation and high reliability.

1.2. SPECIFICATIONS

Function Overview		Preview, Recording, Playback, Network
A/V input and output	IPC Input	Built-in pon:16*1080p@30fps(n9m Protocol), 10/100m,dc12v Supports external switch for 8 channels;
	A/V Output	Not support
	Analog input Channel	Not support
	Audio and Video coding	Audio encoding: adpcm/g.711
	Audio and video decoding	h.264/h.265
Display	Display Split	support
	OSD	GPS information, alarm, license plate, speed, date/time
	Operation Interface	Semi-transparent GUI
Recording	Stream (IPC)	Single channel maximum code flow:16 mbps/channel, typical code flow is 8mbps/channel; (Main stream + sub-stream); Total Channel bit rate: >140 Mbps (8Mbps + 750Kbps) * Channels); 24-channel IPC access supporting reduced frame rate/bit rate; 4K resolution IPC access supporting reduced frame rate/bit rate;
	Resolution	4k@30fps, the5mp@30fps,4mp@30fps,3mp@30fps,1.3mp@30fps,1080p@30fps,720p@30fps ,wd1@30fps, d1@30fps,2cif30fps,cif@30fps
	ONVIF	Support, frame rate/bit rate can be reduced by 40%;

	protocol	
	N9M Protocol	Supports N9M Protocol Full Frame Rate IPC;
Playback/preview	Local	Not support
	WEB	Support, connect RJ45 port, back panel
Network	AP WIFI	x2,802.11a/b/g/n 2.4ghz/5ghz, back panel
	WIFI	Built-in modules, PCIE Mini interface, support 802.11b/g/n/ac; Support dual-frequency 2.4ghz/5ghz; support 2*2mimo (can support 3*3mimo; back panel
Locating	GPS	Location tracking, speed detection and time sync
Storage	Hard disk + SD card	2 x SSD or HDD + 1 x SD card
	FLASH	Built-in
Interface	USB	1 x USB3.0 (Type A) + 1 x USB2.0 (Type B)
	eSATA	1 pcs
	SD	1 x SD slot
	SIM	1*push-push
	AUX	2 pcs
	RS485	1 pcs
	Wakeup button	1 pcs
	J1939	2 pcs
	Panic	1 pcs
	RJ45	3 pcs (optional) with lights
	IO inputs	8 pcs
Power	Power Input	DC8-36V, ACC
	Max Power Consumption	96W
	Standby Power Consumption	≈0W
Environment	Operating Temperature	-10°C~ +70°C; -40°C~ +70°C(With heater)
	Operating Relative Humidity	8%-90% (No Condense)

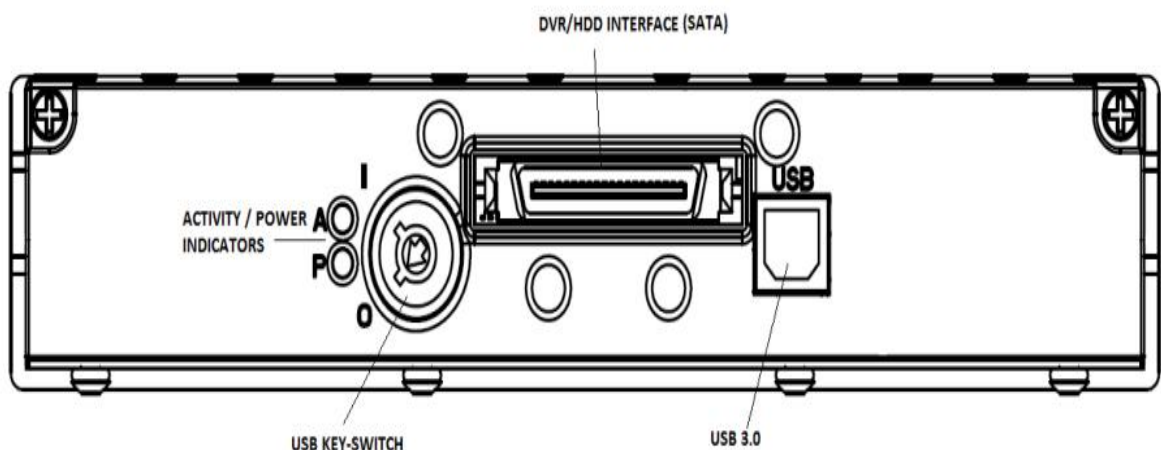

Name	Label	Description	Type	Manufacture/PN
USB 3.0	USB	USB Connection to PC	USB 3.0 B female	Amphenol GSB321131HR OR Foxconn UEB1112c-2ak1-4F,90° OR TBD
Activity Indicator	A	Activity indicator LED	Amber LED (3mm)	(not specified)
Power Indicator	P	Power indicator LED	Green LED (3mm)	(not specified)
USB Key-switch	I/O	Key-switch to enable/disable USB	Barrel key-switch	(not specified)
DVR/HDD Interface	-	Interface to DVR (see section 5.2)	SCA-240 pin plug	FCI 71292-204LF

5.1.1. HDD Module Back Panel

2. FREQUENTLY ASKED QUESTIONS

1) The system can't start?

Usually this problem results from the incorrect power connection. Please follow below steps to check the power connection:

1. Check the input power, whether the power wire is connected correctly, whether the ground wire is connected back to the battery, and whether the fuse on the power wire is in good condition.
2. Check whether the ACC signal wire input to the power is with voltage higher than 7 V.
3. Check whether the device key is closed.

2) The MDVR restarts uninterruptedly?

Please follow below steps to check it:

1. Check whether the voltage of MDVR is insufficient. If the voltage is less than the start-up voltage of the device, the device would always restart.
2. The problem in hard disk/SD card may cause the failure to start. Take off the storage part and check whether it is broken down.

3) The device can't record?

Usually this problem results from the storage disk or camera. Please follow below steps to check it:

1. Check whether the storage disk is installed, whether it is in good contact, and whether the disk can be read normally in computer.
2. Check whether the storage disk is formatted. The storage disk should be formatted before normally storing record files.
3. Check whether there is video signal input into the device from camera, and whether there is video/image on the screen.

4) There is no voice in record file?

Please follow below steps to check it:

1. Check whether there is an external pickup, or whether the camera features with the function of audio collection.
2. Access to Video Channel Settings, check if Audio is set on.
3. There must be video input into the channel for recording and it must record normally.

5) The GPS works abnormally?

Please follow below steps to check it:

1. Check whether the GPS antenna is installed correctly. There is a silk print logo on the GPS antenna holder behind the host device.
2. Check whether the antenna receiver is sheltered. It should not be covered by any stuff, which may cause it not to receive signals.
3. Environmental influence such as tree shades, being inside tunnel, driving near tall building or elevated roads, thunderstorms or other weather influence, etc. can also cause signal loss or receiving wrong signals.

6) The device can't shutdown in ignition switch mode?

Please follow below steps to check it:

1. Check if the ACC line connection mode is correct; and check whether there is voltage on ACC yellow line when the key is turned off.
2. If the device has been set with schedule recording, it can't shutdown if it is still during recording time

of the task table.

7) How to install the WIFI antenna?

The antenna must be installed on unobstructed place of the roof, and be fixed with glue.

8) The device cannot be shut down when in ignition ON/OFF mode.

Check if the ACC signal wiring is correct and if there is voltage for ACC signal line after the key is turned off .

If you have set timing recording, and at the current time it is still in task recording, the device may be impossible to be shut down.

9) GPS anomaly.

Check if the GPS antenna is properly installed. There is silkscreen GPS identification on the GPS antenna pedestal on the back of the MDVR device. Check if the antenna connector is blocked and make sure the antenna connector not be covered by other things.

Trees block, being inside the tunnel, driving near tall buildings or viaduct, thunderstorms and other environmental effects may also cause to receive no GPS signal or error signal.

10) No voice in video files.

See if there is an external microphone, or if the camera cannot capture audio;

Enter into the video channel settings, then check if the audio is open;

Ensure video input and normal recording, on which the audio recording channels must be based.

11) The device doesn't record.

Make sure the storage part is installed and of fine contact, the data can be read on PC, and the storage device is not formatted.

Check if there are video signal input to the main device, and whether there are video images in the channel pictures.

12) Why has the MDVR device always been in a state of restart?

Check whether the MDVR device voltage is insufficient. If the device voltage does not reach the start voltage, the device will restart.

Hard disk or SD card may cause the MDVR device unable to start. You need to remove the storage device and then boot up to verify whether it is caused by the storage device.

13) Why the MDVR device cannot start?

Check the device input power to see if the power wiring is correct, if there is ground wire connected back to the battery, and if the fuse of the power wire is in good condition;

Check whether there is voltage (more than 7V) on power input ACC signal wire;

Check whether the hard disk key is turned off.

14) What is the log in user name and password for new device?

The default user name and password are both "admin". The device password can be set as empty.

15) In the ON/OFF of basic settings, the low voltage protection is 8V, why?

After testing, when the battery is lower than 8V, the voltage will lower down quickly. Therefore the lowest voltage is set to be 8V. When it is lower than 8V, the MDVR device will recognize it as external power-off and then enter into shutdown state.

3. FCC Statement

Changes or modifications not expressly approved by the party responsible for compliance could void the user's authority to operate the equipment.

This equipment has been tested and found to comply with the limits for a Class B digital device, pursuant to Part 15 of the FCC Rules. These limits are designed to provide reasonable protection against harmful interference in a residential installation. This equipment generates uses and can radiate radio frequency energy and, if not installed and used in accordance with the

instructions, may cause harmful interference to radio communications. However, there is no guarantee that interference will not occur in a particular installation. If this equipment does cause harmful interference to radio or television reception, which can be determined by turning the equipment off and on, the user is encouraged to try to correct the interference by one or more of the following measures:

- Reorient or relocate the receiving antenna.
- Increase the separation between the equipment and receiver.
- Connect the equipment into an outlet on a circuit different from that to which the receiver is connected.
- Consult the dealer or an experienced radio/TV technician for help

This device complies with part 15 of the FCC rules. Operation is subject to the following two conditions (1) this device may not cause harmful interference, and (2) this device must accept any interference received, including interference that may cause undesired operation.

This device is acting as slave and operating in the 2.4 GHz (2412 ~2462 MHz) band. Ad Hoc function is supported but not able to operate on non-US frequencies.

--FCC Radio Frequency Exposure Statement

The antennas must be installed to provide a separation distance of at least 20 cm to any human body.

Operation of this device is restricted to indoor use only. (5G WIFI)