

**User Manual
For Digital Video
Recorder
(Model HD6-1200
and HD6-1200W)**



Notice

The information in this manual was current when published. The manufacturer reserves the right to revise and improve its products. All specifications are therefore subject to change without any notice.

The purpose of this manual is to kindly aid the user for the operation for our Digital Video Recorder (Hereinafter referred to as DVR). The user should have a basic understanding of computer operation and basic knowledge of how to connect peripherals and make some settings.

Guarantee & Warnings

1) Electrical Apparatus Safety

This DVR equipment has been tested and found to comply with the limits pursuant to title 47 part 15 subpart E of the FCC rules. All installation and operation should comply with local electrical safety norms.

2) Transportation

In the process of transportation, storage and installation, please avoid heavy stress, violent vibration, impact and water splashing.

3) Installation

Install the equipment in accordance with the requirements, handle carefully. Do not heavily press the equipment before the equipment installation is finished.

4) Requirements on Engineers & Technicians

All the work of checking and maintenance should be done by qualified technicians and engineers. We do not undertake any responsibility caused by unauthorized modifications.

5) Requirements on Environment

The equipment should be installed and stored in a cool and dry place, away from direct sunlight, flammable or explosive substances, etc. Keep gaps not less than 3cm around the equipment to facilitate ventilation for cooling.

6) Accessories

Make sure to use accessories from the manufacturer recommended in the attachment.

Insulate circuit ground and metal shell for all the peripherals.

Before installation, please open the package and ensure that all parts are included.

If there are any problems, please contact us as soon as possible.

1. PRODUCT CHARACTERISTICS

1.1. OVERVIEW

HD6-1200/HD6-1200W is developed from the brand new platform N9M, which is an advanced and function-extensive Mobile Digital Video Recorder specially designed for network high definition, analog audio & video input and excellent extension. It uses high-speed processor and embedded operating system, patented file system 5.0 to ensure the safety and integration of important data, combining with H.264/H.265 video compression/ decompression technology, network technology and GPS locating technology. It can implement AHD 1080P and 720P high definition, IP camera 5MP, 4MP, 1080P and 720P high definition, WD1, WHD1, WCIF, D1, HD1, CIF video recording and vehicle driving information recording, as well as wireless data upload. With video center software it also achieves alarm linkage central monitoring, remote management and playback analysis. It is powerful with modular design, flexible installation, easy maintenance and high reliability.

1.2. SPECIFICATIONS

Function Overview		Preview, Recording, Playback, Network transmission, Locating
System	OS	Linux
	Control Mode	Easy Check, Network, Mouse, web browser
Video	Input	8 channels AHD+ 4 channel IPC
	Output	1 channel (RCA)
	Total Resource	PAL: 8*720P@25FPS (AHD) +4*1080P@30FPS (IPC) Or 8*1080P@12FPS (AHD) +4*1080P@30FPS (IPC) NTSC: 8*720P@30FPS (AHD)+4*1080P@30FPS (IPC) Or 8*1080P@15FPS (AHD)+4*1080P@30FPS (IPC)
	Video Signal Standard	Electrical level: 1Vpp Impedance : 75Ω NTSC/PAL Optional
Audio	Input	12 channels (4 channel IPC audio input)
	Output	1 channel (RCA)
	Audio Signal Standard	Electrical level: 2Vpp Input impedance: 4.7kΩ
Display	Display Split	1-12 adjustable
	OSD	GPS information, alarm, license plate, speed, date/time
	Operation Interface	Semi-transparent GUI
Recording	Video/Audio Compression	Video: H.264 /H.265 Audio: ADPCM
	Image Resolution	PAL: 1080P, 720P, WD1(928X576), WHD1(928X288), WCIF(464X288), D1(704X576), HD1(704x288), CIF(352x288);
		NTSC: 1080P, 720P, WD1(928X480), WHD1(928X240), WCIF(464 x240), D1(704 x480), HD1(704 x240), CIF(352 x240)

		Digital: 3MP(2048 X 1536), 4MP(2560 X 1440), 5MP(2560 X 1920), 1080P(1920X1080), 720P(1280X720)
	Image Quality	1-8 levels adjustable (1 is the best)
	Recording Mode	Boot up/Schedule/Alarm
	Pre- recording	0-5 minutes
	Post-recording	0-30 minutes
	Mirror/Dual Recording	Support
	Playback	Playback Channel
Search Mode		Date/time, channel, event
Network	WIFI	802.11b/g/n (2.4GHz and 5.8GHz)
	IPC Ethernet (Back)	4 x10/100 M RJ45 ports
	Ethernet port (Front)	1 x10/100M RJ45 port(Connect to PC for testing)
Locating	GPS	Location tracking, speed detection and time sync
Storage	Hard disk + SD card	1 x HDD + 1 x SD card
Interface	USB	2 x USB2.0 (Type A) + 1 x USB2.0 (Type B)
	SD	1 x SD slot
	SIM	1 x SIM slot
	Sensor	8 inputs, 2 outputs
	Panic	1 x Panic
	RS232	1 x Extend GPS interface
	RS485	1 x ACC
	J1939	2 x CAN
	AUX	2 x DC12V/1A Output
	ESATA	1 x EXT HDD
Power	Input	DC8-36V
	Max Power	116W
	Consumption	
	Standby Power	≈0W
Physical Characteristic	Dimension (L × W × H)(mm)	320.5 x 187.4 x 101.5mm
	Weight	3.2 Kg (Without HDD)
Environment	Operating Temperature	-10℃~ +60℃; -40℃~ +60℃(With heater)
	Operating Relative Humidity	8%-90% (No Condense)

1.3. DIMENSION

Unit: mm

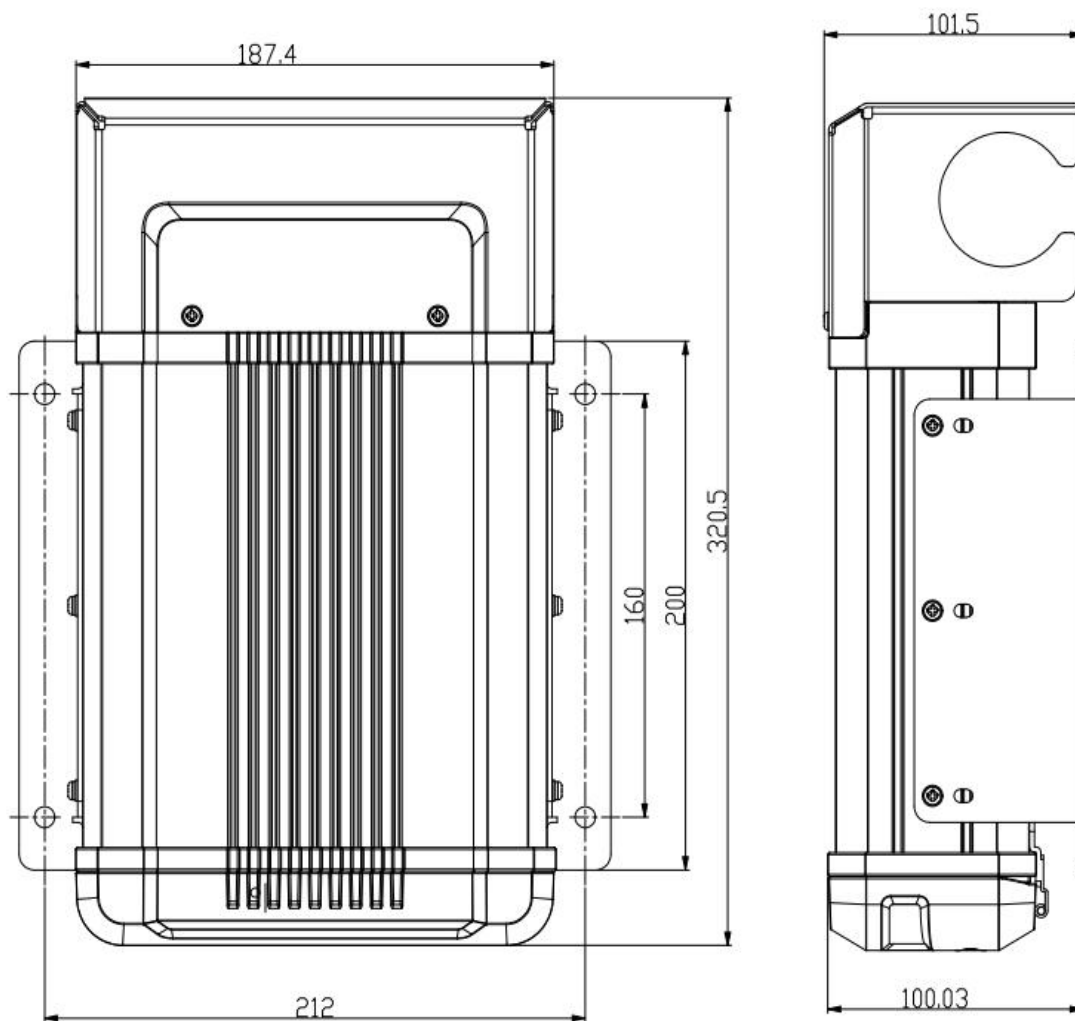

1.4. PANEL INTERFACE

Front panel

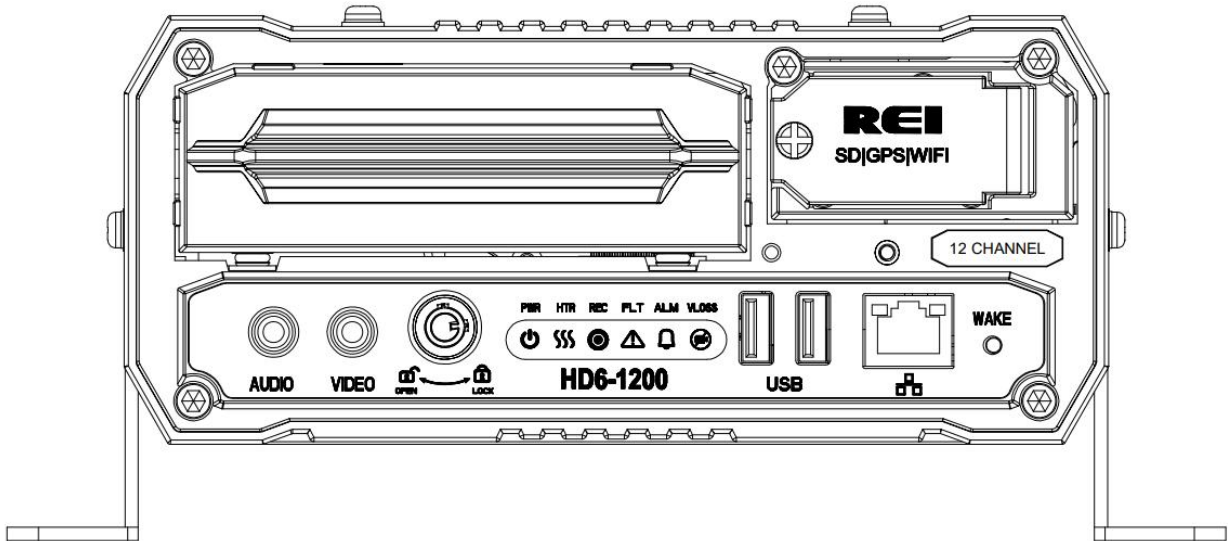

Serial No.	Print	Description
1	AUDIO	Audio out
2	VIDEO	Video out
3	PWR	Power LED
4	HTR	Heater LED
5	REC	Recording LED
6	FLT	Fault LED
7	ALM	Alarm LED
8	VLOSS	Video loss LED
9	USB	2 x USB 2.0
10	RJ45	1 x 10/100/1000M RJ45
11	WAKE	Wake Button

Rear panel:

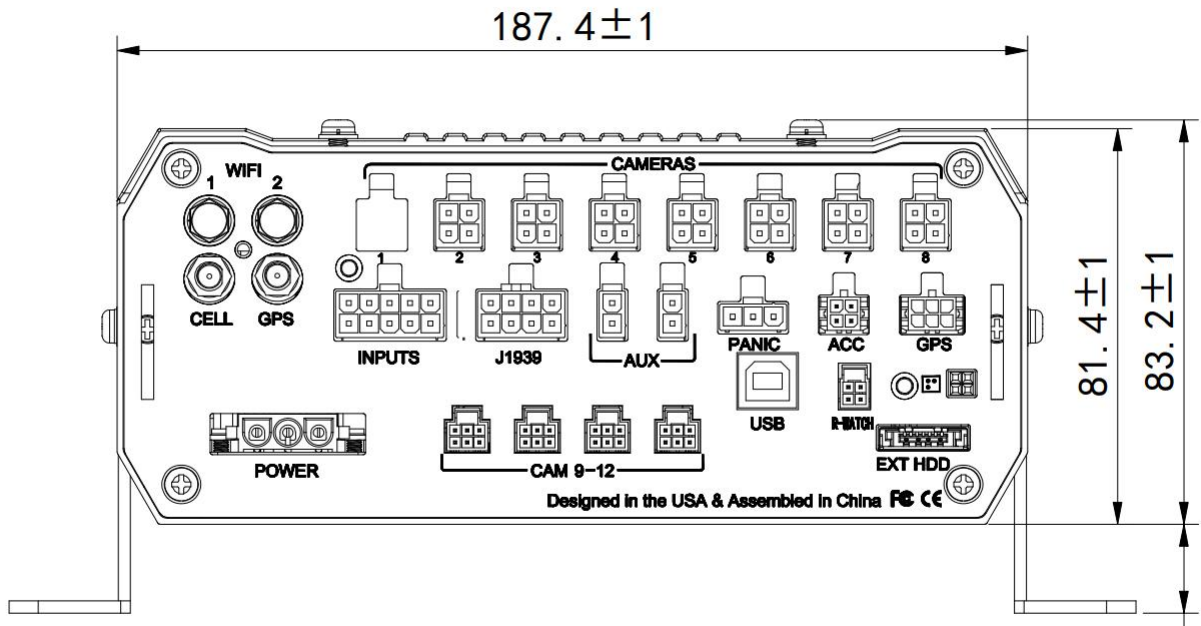

Serial No.	Print	Description
1	Power	DC8-36V power input
2	CAM9-12	IP Camera input 9~12
3	USB	USB2.0 port (Type B/ to connect fire proof box)
4	EXT HDD	ESATA Connector
5	CAMERAS	AHD A/V input 1~8
6	WIFI	WIFI 1-2 antenna port (2.4GHz & 5.8GHz)
7	GPS	GPS antenna port
8	INPUT	Sensor input
9	J1939	2 x CAN Ports
10	AUX	2 x DC12V/1A Out Ports
11	PANIC	1 x Panic Port
12	ACC	1 x ACC Port
13	GPS	1 x Extended GPS Port

2. FREQUENTLY ASKED QUESTIONS

1) The system can't start?

Usually this problem results from the incorrect power connection. Please follow below steps to check the power connection:

1. Check the input power, whether the power wire is connected correctly, whether the ground wire is connected back to the battery, and whether the fuse on the power wire is in good condition.
2. Check whether the ACC signal wire input to the power is with voltage higher than 7 V.
3. Check whether the equipment key is closed.

2) The DVR restarts uninterruptedly?

Please follow below steps to check it:

1. Check whether the voltage of DVR equipment is insufficient. If the voltage is less than the start-up voltage of the equipment, the equipment would always restart.
2. The problem in hard disk/SD card may cause the failure to start. Take off the storage part and check whether it is broken down.

3) The DVR can't record?

Usually, this problem results from the storage disk or camera. Please follow below steps to check it:

1. Check whether the storage disk is installed, whether it is in good contact, and whether the disk can be read normally in computer.
2. Check whether the storage disk is formatted. The storage disk should be formatted before normally storing record files.
3. Check whether there is video signal input into the equipment from camera, and whether there is video/image on the screen.

4) There is no voice in record file?

Please follow below steps to check it:

1. Check whether there is an external pickup, or whether the camera features with the function of audio collection.
2. Access to Video Channel Settings, check if Audio is set on.
3. There must be video input into the channel for recording and it must record normally.

5) The GPS works abnormally?

Please follow below steps to check it:

1. Check whether the GPS antenna is installed correctly. There is a silk print logo on the GPS antenna holder behind the host equipment.
2. Check whether the antenna receiver is sheltered. It should not be covered by any stuff, which may cause it not to receive signals.
3. Environmental influence such as tree shades, being inside tunnel, driving near tall building or elevated roads, thunderstorms or other weather influence, etc. can also cause signal loss or receiving wrong signals.

6) The DVR can't shutdown in ignition switch mode?

Please follow below steps to check it:

1. Check if the ACC line connection mode is correct; and check whether there is voltage on ACC yellow line when the key is turned off.

-
2. If the equipment has been set with schedule recording, it can't shutdown if it is still during recording time of the task table.
- 7) How to install the WIFI antenna?**
The antenna must be installed on unobstructed place of the roof, and be fixed with glue.
- 8) The DVR cannot be shut down when in ignition ON/OFF mode.**
Check if the ACC signal wiring is correct and if there is voltage for ACC signal line after the key is turned off .
If you have set timing recording, and at the current time it is still in task recording, the equipment may be impossible to be shut down.
- 9) GPS anomaly.**
Check if the GPS antenna is properly installed. There is silkscreen GPS identification on the GPS antenna pedestal on the back of the DVR equipment. Check if the antenna connector is blocked and make sure the antenna connector not be covered by other things.
Trees block, being inside the tunnel, driving near tall buildings or viaduct, thunderstorms and other environmental effects may also cause to receive no GPS signal or error signal.
- 10) No voice in video files.**
See if there is an external microphone, or if the camera cannot capture audio;
Enter into the video channel settings, then check if the audio is open;
Ensure video input and normal recording, on which the audio recording channels must be based.
- 11) The DVR doesn't record.**
Make sure the storage part is installed and of fine contact, the data can be read on PC, and the storage equipment is not formatted.
Check if there are video signal input to the main equipment, and whether there are video images in the channel pictures.
- 12) Why has the DVR always been in a state of restart?**
Check whether the DVR equipment voltage is insufficient. If the equipment voltage does not reach the start voltage, the equipment will restart.
Hard disk or SD card may cause the DVR equipment unable to start. You need to remove the storage equipment and then boot up to verify whether it is caused by the storage equipment.
- 13) Why the DVR cannot start?**
Check the equipment input power to see if the power wiring is correct, if there is ground wire connected back to the battery, and if the fuse of the power wire is in good condition;
Check whether there is voltage(more than 7V) on power input ACC signal wire;
Check whether the hard disk key is turned off.
- 14) What is the log in user name and password for new DVR?**
The default user name and password are both "admin". The equipment password can be set as empty.
- 15) In the ON/OFF of basic settings, the low voltage protection is 8V, why?**
After testing, when the battery is lower than 8V, the voltage will lower down quickly. Therefore the lowest voltage is set to be 8V. When it is lower than 8V, the DVR equipment will recognize it as external power-off and then enter into shutdown state.

3. FCC Statement

Changes or modifications not expressly approved by the party responsible for compliance could void the user's authority to operate the equipment.

This equipment has been tested and found to comply with the limits for a Class B digital equipment, pursuant to Part 15 of the FCC Rules. These limits are designed to provide reasonable protection against harmful interference in a residential installation. This equipment generates uses and can radiate radio frequency energy and, if not installed and used in accordance with the

instructions, may cause harmful interference to radio communications. However, there is no guarantee that interference will not occur in a particular installation. If this equipment does cause harmful interference to radio or television reception, which can be determined by turning the equipment off and on, the user is encouraged to try to correct the interference by one or more of the following measures:

- Reorient or relocate the receiving antenna.
- Increase the separation between the equipment and receiver.
- Connect the equipment into an outlet on a circuit different from that to which the receiver is connected.
- Consult the dealer or an experienced radio/TV technician for help

This equipment complies with part 15 of the FCC rules. Operation is subject to the following two conditions (1) this equipment may not cause harmful interference, and (2) this equipment must accept any interference received, including interference that may cause undesired operation.

4. RF Exposure Statement

To maintain compliance with FCC's RF Exposure guidelines, This equipment should be installed and operated with minimum distance of 20cm the radiator your body. This device and its antenna(s) must not be co-located or operation in conjunction with any other antenna or transmitter.

