



Test report No:  
2150995R-RF-US-P06V01

## FCC & ISED TEST REPORT

Product Name	Wireless Headset
Trademark	
Model and /or type reference	CFI-ZWH1
FCC ID	SZGCFIZWH1
IC	7702A-CFIZWH1
Applicant's name / address	Weifang Goertek Electronics Co., Ltd Gaoxin 2 Road, Free Trade Zone, Weifang, Shandong, 261205, P.R. China
Test method requested, standard	FCC CFR Title 47 Part 15 Subpart C Section 15.247 ANSI C63.10: 2013 KD558074 D01 15.247 Meas Guidance v05r02 RSS-Gen Issue 5 RSS-247 Issue 2
Verdict Summary	IN COMPLIANCE
Documented by (name / position & signature)	Tim Cao/ Project Engineer 
Approved by (name / position & signature)	Jack Zhang/ Supervisor 
Date of issue	2021-07-09
Report version	V1.1
Report template No	Template_FCC 15.247-RF-V1.0

## INDEX

	page
General conditions .....	4
Environmental conditions .....	4
Possible test case verdicts .....	5
Abbreviations .....	5
Document History .....	6
Remarks and Comments.....	6
Used Equipment .....	7
Uncertainty .....	9
1 General Information.....	10
1.1 General Description of the Item(s) .....	10
1.2 Antenna Information .....	11
1.3 Channel List .....	12
1.4 Software for the EUT .....	12
2 Description of Test Setup .....	13
2.1 Operating mode(s) used for tests.....	13
2.2 Test Configuration / Block diagram used for tests .....	14
2.3 Testing process .....	15
3 Verdict summary section .....	16
3.1 Standards.....	16
3.2 Deviation(s) from the Standard(s) / Test Specification(s).....	16
3.3 Overview of results.....	17
3.4 Test Facility.....	18
4 Test Results .....	19
4.1 AC Power Line Conducted Emission .....	19
4.1.1 Limit .....	19
4.1.2 Test Setup.....	19
4.1.3 Test Procedure.....	19
4.1.4 Test Data .....	20
4.2 Emissions in restricted frequency bands .....	22
4.2.1 Limit .....	22
4.2.2 Test Setup.....	24
4.2.3 Test Procedure.....	24
4.2.4 Test Data .....	25
4.3 Emissions in non-restricted frequency band.....	33

---

4.3.1	Limit .....	33
4.3.2	Test Setup.....	33
4.3.3	Test Procedure.....	33
4.3.4	Test Data .....	34
4.4	Duty cycle .....	35
4.4.1	Limit .....	35
4.4.2	Test Setup.....	35
4.4.3	Test Procedure.....	35
4.4.4	Test Data .....	36
4.5	Radiated Emission Band Edge .....	37
4.5.1	Limit .....	37
4.5.2	Test Setup.....	37
4.5.3	Test Procedure.....	37
4.5.4	Test Data .....	38
4.6	DTS Bandwidth .....	46
4.6.1	Limit .....	46
4.6.2	Test Setup.....	46
4.6.3	Test Procedure.....	46
4.6.4	Test Data .....	47
4.7	Fundamental emission output power .....	48
4.7.1	Limit .....	48
4.7.2	Test Setup.....	48
4.7.3	Test Procedure.....	49
4.7.4	Test Data .....	50
4.8	Power Density .....	51
4.8.1	Limit:.....	51
4.8.2	Test Setup.....	51
4.8.3	Test Procedure.....	51
4.8.4	Test Data .....	52
4.9	Antenna Requirement.....	53
4.9.1	Limit:.....	53
4.9.2	Antenna Connector Construction: .....	53
5	Test setup photo and EUT Photo.....	54

## COMPETENCES AND GUARANTEES

DEKRA is a testing laboratory competent to carry out the tests described in this report.

In order to assure the traceability to other national and international laboratories, DEKRA has a calibration and maintenance program for its measurement equipment.

DEKRA guarantees the reliability of the data presented in this report, which is the result of the measurements and the tests performed to the item under test on the date and under the conditions stated in the report and it is based on the knowledge and technical facilities available at DEKRA at the time of performance of the test.

DEKRA is liable to the client for the maintenance of the confidentiality of all information related to the item under test and the results of the test.

The results presented in this Test Report apply only to the particular item under test established in this document.

**IMPORTANT:** No parts of this report may be reproduced or quoted out of context, in any form or by any means, except in full, without the previous written permission of DEKRA.

## GENERAL CONDITIONS

Test Location	No. 99, Hongye Road, Suzhou Industrial Park Suzhou, 215006, P.R. China
Date(receive sample)	May. 31, 2021
Date (start test)	Jun. 04, 2021
Date (finish test)	Jun. 22, 2021

1. This report is only referred to the item that has undergone the test.
2. This report does not constitute or imply on its own an approval of the product by the Certification Bodies or Competent Authorities.
3. This document is only valid if complete; no partial reproduction can be made without previous written permission of DEKRA.
4. This test report cannot be used partially or in full for publicity and/or promotional purposes without previous written permission of DEKRA.

## ENVIRONMENTAL CONDITIONS

The climatic conditions during the tests are within the limits specified by the manufacturer for the operation of the EUT and the test equipment. The climatic conditions during the tests were within the following limits:

Ambient temperature	15 °C – 35 °C
Relative Humidity air	30% - 60%

If explicitly required in the basic standard or applied product / product family standard the climatic values are recorded and documented separately in this test report.

---

## POSSIBLE TEST CASE VERDICTS

---

Test case does not apply to test object	N/A
Test object does meet requirement	P (Pass) / PASS
Test object does not meet requirement	F (Fail) / FAIL
Not measured	N/M

---

## ABBREVIATIONS

---

For the purposes of the present document, the following abbreviations apply:

EUT	: Equipment Under Test
QP	: Quasi-Peak
CAV	: CISPR Average
AV	: Average
CDN	: Coupling Decoupling Network
SAC	: Semi-Anechoic Chamber
OATS	: Open Area Test Site
BW	: Bandwidth
AM	: Amplitude Modulation
PM	: Pulse Modulation
HCP	: Horizontal Coupling Plane
VCP	: Vertical Coupling Plane
$U_N$	: Nominal voltage
$T_x$	: Transmitter
$R_x$	: Receiver
N/A	: Not Applicable
N/M	: Not Measured

## DOCUMENT HISTORY

Report No.	Version	Description	Issued Date
2150995R-RF-US-P06V01	V1.0	Initial issue of report.	2021-06-30
2150995R-RF-US-P06V01	V1.1	Page 7,8: Update used equipment list; Page 10: Update EUT information. Page 12: Add power setting. (The test report No.: 2150995R-RF-US-P06V01 V1.1 is to replace the test report No.: 2150995R-RF-US-P06V01 V1.0, and test report 2150995R-RF-US-P06V01 V1.0 is obsoleted.)	2021-07-09

Note: This report is based on the DEKRA report (Report No. : 2060465R-RF-US-P06V01). The product has been updated to a new design (the main change is the PCB layout). The change has no effect on the RF circuit, so we only re-evaluate the bandedge and suprious emission to verify compliance, other data are quoted from the original report.

## REMARKS AND COMMENTS

- The equipment under test (EUT) does meet the essential requirements of the stated standard(s)/test(s).
- These test results on a sample of the device are for the purpose of demonstrating Compliance with Part 15 Subpart C Paragraph 15.247, RSS-Gen Issue 5, RSS-247 Issue 2.
- The measurement result is considered in conformance with the requirement if it is within the prescribed limit, It is not necessary to account the uncertainty associated with the measurement result.
- The test results presented in this report relate only to the object tested.
- The test report shall not be reproduced without the written approval of DEKRA Testing and Certification (Suzhou) Co., Ltd.
- This report will not be used for social proof function in China market.
- DEKRA declines any responsibility with the following test data provided by customer that may affect the validity of result:
  - Chapter 1.1 General Description of the Item(s);
  - Chapter 1.2 Antenna Informaion;
  - Chapter 1.3 Channel List;
  - Chapter 1.4 Power Setting;
  - Chapter 1.5 software for the EUT.

## USED EQUIPMENT

### AC Power Line Conducted Emission / TR1

Instrument	Manufacturer	Model No.	Serial No.	Cal. Date	Next Cal. Date
EMI Test Receiver	R&S	ESCI	100906	2021.04.28	2022.04.27
Two-Line V-Network	R&S	ENV216	101190	2021.01.27	2022.01.26
Two-Line V-Network	R&S	ENV216	101044	2021.03.20	2022.03.19
Current Probe	R&S	EZ-17	100678	2021.01.27	2022.01.26
50ohm Termination	SHX	TF2	07081402	2020.09.23	2021.09.22
50ohm Termination	SHX	TF2	07081403	2020.09.23	2021.09.22
50ohm Coaxial Switch	Anritsu	MP59B	6200464462	N/A	N/A
Temperature/Humidity Meter	RTS	RTS-8S	TR1-TH	2020.08.13	2021.08.12
Coaxial Cable	Suhner	RG 223	TR1-C1	2021.03.31	2022.03.30
Coaxial Cable	Suhner	RG 223	TR1-C2	2021.03.31	2022.03.30
Dekra test software	Dekra	-	-	-	-

### Emissions in non-restricted frequency bands/ Occupied Bandwidth/ Fundamental emission output power Power Spectral Density / TR8

Instrument	Manufacturer	Model No.	Serial No.	Cal. Date	Next Cal. Date
Spectrum Analyzer	Agilent	N9010A	MY48030494	2020.08.15	2021.08.14
EXA Spectrum Analyzer	Keysight	N9010A	MY55370495	2021.03.20	2022.03.19
MXA Signal Analyzer	Keysight	N9020A	MY56060147	2020.08.15	2021.08.14
EPM Series Power Meter	Agilent	E4418B	MY50000118	2019.09.04	2021.09.03
E-Series Power Sensor	Agilent	E9304A	MY50000187	2019.09.04	2021.09.03
Coaxial Cable	Woken	SFL402	F02-150410-044	2021.03.31	2022.03.30
Dekra test software	Dekra	-	-	-	-

### Radiated Emission(30MHz-1GHz) / AC3

Instrument	Manufacturer	Model No.	Serial No.	Cal. Date	Next Cal. Date
EMI Test Receiver	R&S	ESCI	100573	2020.12.06	2021.12.05
Bilog Antenna	Teseq GmbH	CBL6112D	27611	2020.11.27	2021.11.26
Temperature/Humidity Meter	RTS	RTS-8S	AC2-TH	2020.08.13	2021.08.12
Coaxial Cable	Huber+Suhner	RG 214	AC2-C	2021.03.31	2022.03.30
Dekra test software	Dekra	-	-	-	-

## Radiated Emission / AC5(1GHz-40GHz)

Instrument	Manufacturer	Model No.	Serial No.	Cal. Date	Next Cal. Date
Spectrum Analyzer	Agilent	N9038A	MY51210196	2021.03.20	2022.03.19
Preamplifier	SKET	LNPA_0118G-45	SK2021041201	2021.04.16	2022.04.15
Preamplifier	EMCI	EMC184045SE	980263	2021.05.22	2022.05.21
DRG Horn	ETS-Lindgren	3117	00123988	2020.09.21	2021.09.20
Temperature/Humidity Meter	RTS	RTS-8S	AC5-TH	2020.08.13	2021.08.12
Coaxial Cable	Huber+Suhner	SUCOFLEX 106	AC5-C1	2021.03.31	2022.03.30
Coaxial Cable	Huber+Suhner	SUCOFLEX 106	AC5-C2	2021.03.31	2022.03.30
Coaxial Cable	Huber+Suhner	SUCOFLEX 102	AC5-C3	2021.03.31	2022.03.30
Dekra test software	Dekra	-	-	-	-



## UNCERTAINTY

Uncertainties have been calculated according to the DEKRA internal document. The reported expanded uncertainties are based on a standard uncertainty multiplied by a coverage factor of  $k=2$ , providing a level of confidence of approximately 95%. The Uncertainties is comply with standard required as below.

Test item	Uncertainty
AC Power Line Conducted Emission	9kHz~150kHz: 2.80 dB 150kHz~30MHz: 2.40 dB
Peak Power Output	$\pm 1.27$ dB
Radiated Emission(30MHz~1GHz)	Horizontal: 30MHz~200MHz: 3.50 dB 300MHz~1GHz: 3.60 dB Vertical: 30MHz~200MHz: 3.60 dB 300MHz~1GHz: 3.50 dB
Radiated Emission(1GHz~26.5GHz)	Horizontal: 1GHz~18GHz: 5.00 dB Vertical: 1GHz~18GHz: 4.80 dB
RF antenna conducted test	$\pm 1.27$ dB
Radiated Emission Band Edge	$\pm 3.9$ dB
DTS Bandwidth	$\pm 150$ Hz
Occupied Bandwidth	$\pm 1$ kHz
Power Density	$\pm 1.27$ dB

# 1 GENERAL INFORMATION

## 1.1 General Description of the Item(s)

Product Name..... :	Wireless Headset
Model No. .... :	CFI-ZWH1
FCC ID ..... :	SZGCFIZWH1
IC..... :	7702A-CFIZWH1
Hardware Version ..... :	MP
Software Version..... :	MP
Serial Number..... :	2150995R-1
Manufacturer..... :	Weifang Goertek Electronics Co., Ltd
Manufacturer Address..... :	Gaoxin 2 Road, Free Trade Zone, Weifang, Shandong, 261205, P.R.China

Wireless specification..... :	Special 2.4GHz wireless
Operating frequency range(s)	2405.35- 2477.35 MHz
Type of Modulation..... :	Pi/4 DQPSK
Data Rate ..... :	1Mbps
Number of channel..... :	37

Rated power supply .....	Voltage and Frequency	
	<input type="checkbox"/>	AC: 220 – 240 V, 50/60 Hz
	<input type="checkbox"/>	AC: 100 – 240 V, 50/60 Hz
	<input checked="" type="checkbox"/>	DC: 5 Vdc
	<input checked="" type="checkbox"/>	Battery: 3.65 V
Mounting position..... :	<input type="checkbox"/>	Table top equipment
	<input type="checkbox"/>	Wall/Ceiling mounted equipment
	<input type="checkbox"/>	Floor standing equipment
	<input checked="" type="checkbox"/>	Head-mounted equipment
	<input type="checkbox"/>	Other: RF module

## 1.2 Antenna Information

Antenna model / type number .....	N/A		
Antenna serial number .....	N/A		
Antenna Delivery .....	<input type="checkbox"/>	1TX + 1RX	
	<input checked="" type="checkbox"/>	2TX + 2RX	
Antenna technology .....	<input checked="" type="checkbox"/>	SISO	
	<input type="checkbox"/>	MIMO	<input type="checkbox"/> CDD <input type="checkbox"/> Beam-forming
Antenna Type .....	<input type="checkbox"/>	External	<input type="checkbox"/> Dipole
			<input type="checkbox"/> Sectorized
	<input checked="" type="checkbox"/>	Internal	<input type="checkbox"/> PIFA
			<input checked="" type="checkbox"/> PCB
			<input type="checkbox"/> Metal Monopole Antenna
		<input type="checkbox"/> Others.....	
Antenna Gain.....	Antenna 1: 1.78 dBi Antenna 2: 0.19 dBi		

Note: The EUT has two antennas and share the same RF connector, and will choose the better antenna for different environment. We have evaluated both antennas, shown in the report is the worst data.

### 1.3 Channel List

Working Frequency of Each Channel: For Special 2.4GHz Wireless							
Channel	Frequency	Channel	Frequency	Channel	Frequency	Channel	Frequency
02	2405.35	03	2407.35	04	2409.35	05	2411.35
06	2413.35	07	2415.35	08	2417.35	09	2419.35
10	2421.35	11	2423.35	12	2425.35	13	2427.35
14	2429.35	15	2431.35	16	2433.35	17	2435.35
18	2437.35	19	2439.35	20	2441.35	21	2443.35
22	2445.35	23	2447.35	24	2449.35	25	2451.35
26	2453.35	27	2455.35	28	2457.35	29	2459.35
30	2461.35	31	2463.35	32	2465.35	33	2467.35
34	2469.35	35	2471.35	36	2473.35	37	2475.35
38	2477.35	--	--	--	--	--	--

### 1.4 Power Setting

Mode	Channel	Test Frequency (MHz)	Power Setting
Mode 1	02	2405.35	0x00
	20	2441.35	0x00
	38	2477.35	0x00

### 1.5 Software for the EUT

software	Type / Version	Manufacturer	Supplied by
VMIdebug	N/A	N/A	N/A

Note: The General Description of the Item , antenna information , Channel List, Power setting and the software for the EUT in clause 1 are provided and confirmed by the client.

---

## 2 DESCRIPTION OF TEST SETUP

### 2.1 Operating mode(s) used for tests

During the tests the following operating mode(s) has(have) been used.

Test Mode	Mode1: Transmit by 1Mbps(Pi/4 DQPSK)
-----------	--------------------------------------

## 2.2 Test Configuration / Block diagram used for tests

Test setup Diagram- AC Line Conducted Emission Test

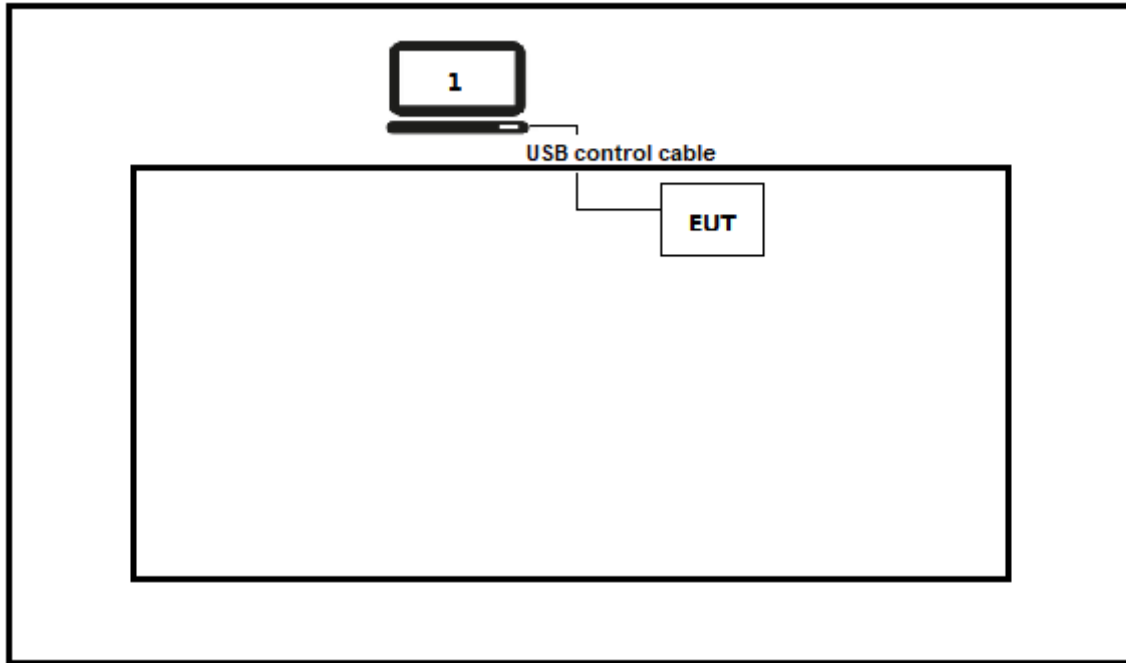

Test setup Diagram- Radiated Emission

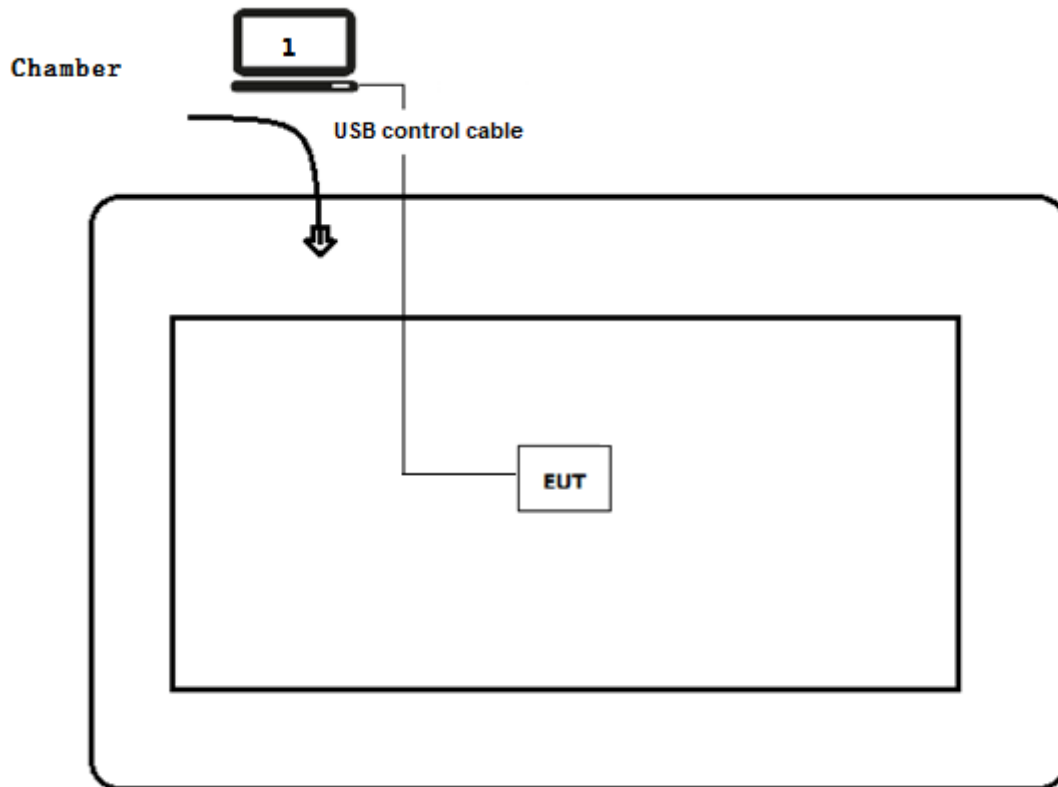

### 2.3 Testing process

1	Setup the EUT as shown in Section 2.4.
2	Turn on the power of equipment.
3	Run the RF test software 【VMldebug】 .
4	Select the transmission mode and test channel, then start test.

### 3 VERDICT SUMMARY SECTION

This chapter presents an overview of standards and results. Refer to the next chapters for details of measured test results and applied test levels.

#### 3.1 Standards

Standard	Year	Description
FCC CFR Title 47 Part 15 Subpart C Section 15.247	2019	Operation within the bands 902–928 MHz, 2400–2483.5 MHz, and 5725–5850 MHz.
ANSI C63.10	2013	American National Standard of Procedures for Compliance Testing of Unlicensed Wireless Devices
KDB 558074 D01 v05r02	2019	Guidance for performing compliance measurements on Digital Transmission System (DTS) operating under section 15.247
RSS-Gen Issue 5 Amendment 1	2019	General Requirements for Compliance of Radio Apparatus
RSS-247 Issue 2	2017	Digital Transmission Systems (DTSs), Frequency Hopping Systems (FHSs) and Licence-Exempt Local Area Network (LE-LAN) Devices

#### 3.2 Deviation(s) from the Standard(s) / Test Specification(s)

The following deviation(s) was / were made from the published requirements of the listed standards: N/A.

*(Please define the deviations from the standard(s) if applicable)*



### 3.3 Overview of results

#### For FCC

Requirement – Test case	Basic standard(s)	Verdict	Remark
AC Power Line Conducted Emission	FCC 15.207	PASS	---
Emissions in restricted frequency bands	FCC 15.247(b)(3)	PASS	---
Duty cycle	ANSI C63.10:2013	PASS	---
Emissions in non-restricted frequency bands	FCC 15.247(d), FCC 15.209	PASS	---
Radiated Emission Band Edge	FCC 15.247(d)	PASS	---
Fundamental emission output power	FCC 15.247(d), FCC 15.209	PASS	---
DTS Bandwidth	FCC 15.247(a)(2)	PASS	---
Power Spectral Density	FCC 15.247(e)	PASS	---
Antenna Requirement	FCC 15.203	PASS	---

#### For ISED

Requirement – Test case	Basic standard(s)	Verdict	Remark
AC Power Line Conducted Emission	RSS-Gen Issue 5 Section 8.8	PASS	---
Emissions in restricted frequency bands	RSS-Gen Issue 5 Section 8.9	PASS	---
Duty cycle	ANSI C63.10:2013	PASS	---
Emissions in non-restricted frequency bands	RSS-247 Issue 2 Section 5.5	PASS	---
Radiated Emission Band Edge	RSS-Gen Issue 5 Section 8.10	PASS	---
Fundamental emission output power	RSS-247 Issue 2 Section 5.4(d)	PASS	---
DTS Bandwidth	RSS-Gen Issue 5 Section 6.7	PASS	---
Power Spectral Density	RSS-247 Issue 2 Section 5.2(b)	PASS	---
Antenna Requirement	RSS-Gen Issue 5 Section 6.8	PASS	---

---

### 3.4 Test Facility

**USA : FCC Designation Number: CN1199**

**CA : ISED CAB identifier: CN0040**

## 4 TEST RESULTS

### 4.1 AC Power Line Conducted Emission

VERDICT: PASS

#### 4.1.1 Limit

Standard		
FCC Part 15 Subpart C Paragraph 15.207		
Frequency range [MHz]	Limit: QP [dB(μV) <sup>1)</sup>	Limit: AV [dB(μV) <sup>1)</sup>
0,15 - 0,50	66 - 56 <sup>2)</sup>	56 - 46 <sup>2)</sup>
0,50 - 5,0	56	46
5,0 - 30	60	50

<sup>1)</sup> At the transition frequency, the lower limit applies.

<sup>2)</sup> The limit decreases linearly with the logarithm of the frequency.

**NOTE 1:** The exclusion band for transmitters shall be considered for transmitters operating at frequencies below 30 MHz.

**NOTE 2:** Where the AC output port is directly connected (or via a circuit breaker) to the AC power input port of the EUT the AC power output port need not to be tested.

#### 4.1.2 Test Setup

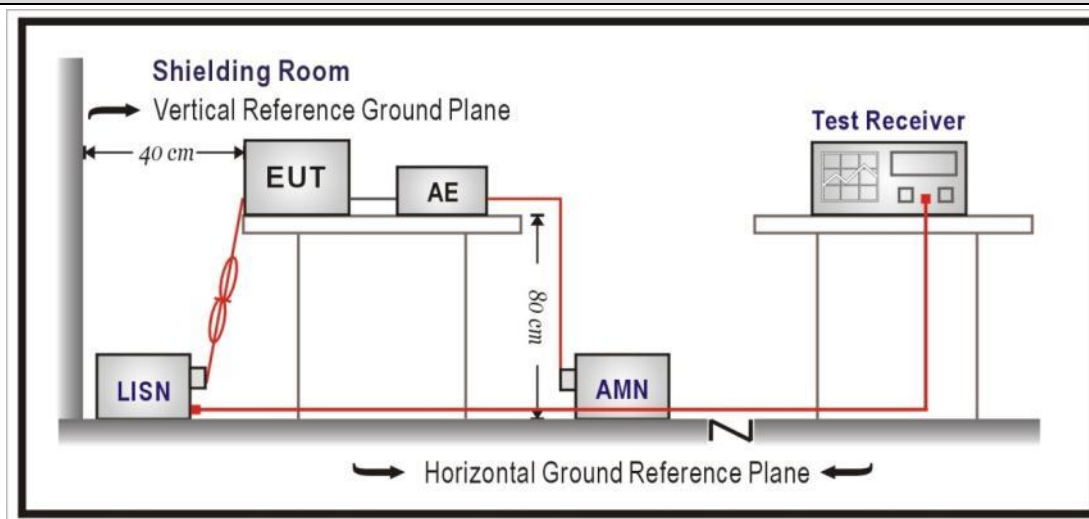

#### 4.1.3 Test Procedure

References Rule	Chapter	Item
<input checked="" type="checkbox"/> ANSI C63.10-2013	6.2	Standard test method for ac power-line conducted emissions from unlicensed wireless devices

**4.1.4 Test Data**

Profile: 2150995R	Page No.: 21
Engineer: Yu Liu	
Site: TR1	Time: 2021/06/23 - 00:19
Limit: FCC_Part15.207_CE_AC Power	Margin: 0
Probe: ENV216_101190(0.009-30MHz)	Polarity: Line
EUT: Wireless Headset	Power: AC 120V/60Hz
Note: Mode 1	

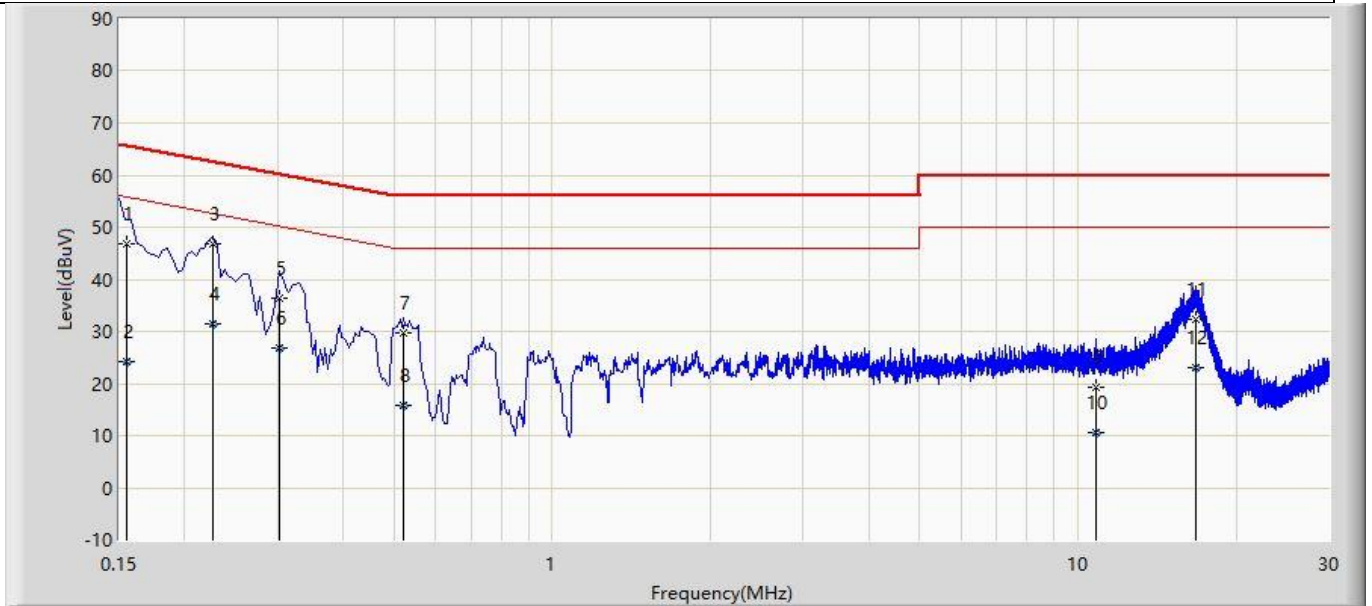

No	Mark	Frequency (MHz)	Measure Level (dBuV)	Reading Level (dBuV)	Over Limit (dB)	Limit (dBuV)	Factor (dB)	Ant Pos (cm)	Table Pos (deg)	Type
1		0.155	46.800	37.142	-18.924	65.725	9.658	0	0	QP
2		0.155	24.280	14.622	-31.444	55.725	9.658	0	0	AV
3	*	0.226	46.795	37.095	-15.800	62.595	9.700	0	0	QP
4		0.226	31.512	21.811	-21.084	52.595	9.700	0	0	AV
5		0.302	36.349	26.611	-23.838	60.188	9.738	0	0	QP
6		0.302	26.922	17.184	-23.266	50.188	9.738	0	0	AV
7		0.522	29.819	19.979	-26.181	56.000	9.840	0	0	QP
8		0.522	15.914	6.075	-30.086	46.000	9.840	0	0	AV
9		10.786	19.266	8.893	-40.734	60.000	10.373	0	0	QP
10		10.786	10.557	0.184	-39.443	50.000	10.373	0	0	AV
11		16.762	32.429	21.906	-27.571	60.000	10.522	0	0	QP
12		16.762	23.084	12.562	-26.916	50.000	10.522	0	0	AV

Profile: 2150995R	Page No.: 22
Engineer: Yu Liu	
Site: TR1	Time: 2021/06/23 - 00:39
Limit: FCC_Part15.207_CE_AC Power	Margin: 0
Probe: ENV216_101190(0.009-30MHz)	Polarity: Neutral
EUT: Wireless Headset	Power: AC 120V/60Hz
Note: Mode 1	

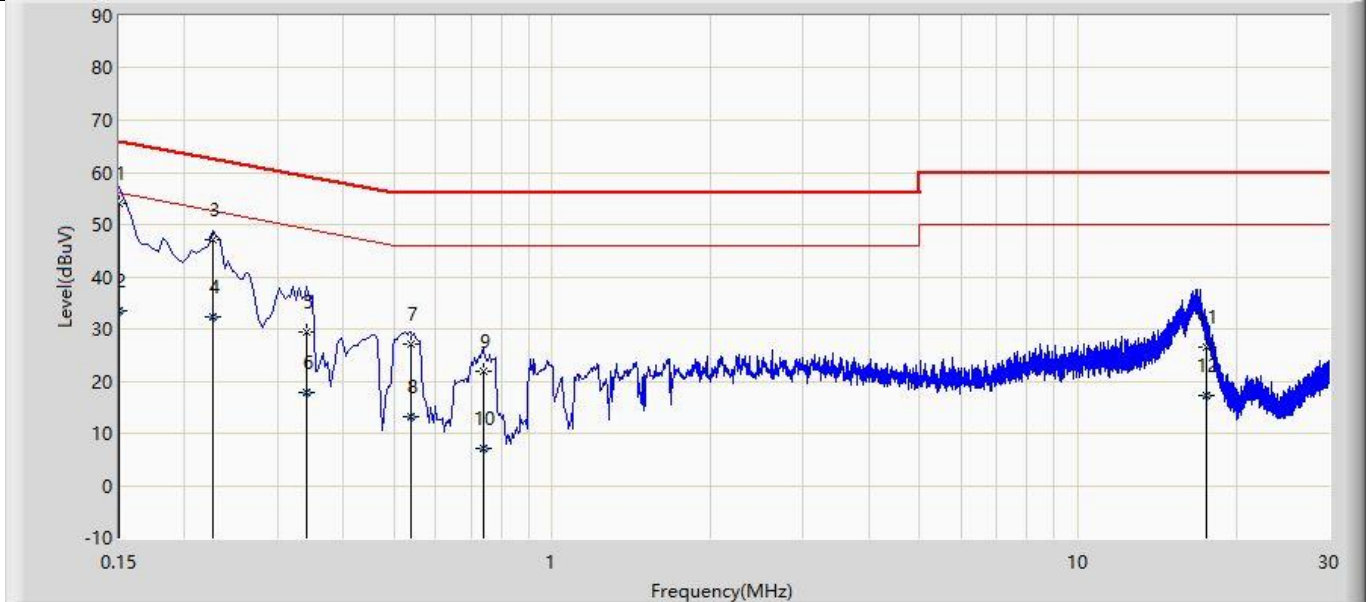

No	Mark	Frequency (MHz)	Measure Level (dBuV)	Reading Level (dBuV)	Over Limit (dB)	Limit (dBuV)	Factor (dB)	Ant Pos (cm)	Table Pos (deg)	Type
1	*	0.150	53.972	44.237	-12.028	66.000	9.735	0	0	QP
2		0.150	33.375	23.640	-22.625	56.000	9.735	0	0	AV
3		0.226	47.156	37.382	-15.439	62.595	9.774	0	0	QP
4		0.226	32.214	22.439	-20.381	52.595	9.774	0	0	AV
5		0.342	29.324	19.520	-29.830	59.155	9.804	0	0	QP
6		0.342	17.701	7.897	-31.453	49.155	9.804	0	0	AV
7		0.538	27.008	17.162	-28.992	56.000	9.846	0	0	QP
8		0.538	13.226	3.380	-32.774	46.000	9.846	0	0	AV
9		0.738	21.905	12.026	-34.095	56.000	9.879	0	0	QP
10		0.738	6.969	-2.910	-39.031	46.000	9.879	0	0	AV
11		17.501	26.406	15.888	-33.594	60.000	10.518	0	0	QP
12		17.501	17.245	6.728	-32.755	50.000	10.518	0	0	AV

Note:

1. " \* ", means this data is the worst emission level.
2. Measurement Level = Reading Level + Factor(Probe+Cable-Amp).

**4.2 Emissions in restricted frequency bands****VERDICT: PASS****4.2.1 Limit****Standard** FCC Part 15 Subpart C Paragraph 15.209

## Restricted Bands of operation

Frequency (MHz)	Frequency (MHz)	Frequency (MHz)	Frequency (GHz)
0.090 – 0.110	16.42 – 16.423	399.9 – 410	4.5 – 5.15
0.495 – 0.505	16.69475 – 16.69525	608 – 614	5.35 – 5.46
2.1735 – 2.1905	16.80425 – 16.80475	960 – 1240	7.25 – 7.75
4.125 – 4.128	25.5 – 25.67	1300 – 1427	8.025 – 8.5
4.17725 – 4.17775	37.5 – 38.25	1435 – 1626.5	9.0 – 9.2
4.20725 – 4.20775	73 – 74.6	1645.5 – 1646.5	9.3 – 9.5
6.215 – 6.218	74.8 – 75.2	1660 – 1710	10.6 – 12.7
6.26775 – 6.26825	108 – 121.94	1718.8 – 1722.2	13.25 – 13.4
6.31175 – 6.31225	123 – 138	2200 – 2300	14.47 – 14.5
8.291 – 8.294	149.9 – 150.05	2310 – 2390	15.35 – 16.2
8.362 – 8.366	156.52475 – 156.52525	2483.5 – 2500	17.7 – 21.4
8.37625 – 8.38675	156.7 – 156.9	2690 – 2900	22.01 – 23.12
8.81425 – 8.81475	162.0125 – 167.17	3260 – 3267	23.6 – 24.0
12.29 – 12.293	167.72 – 173.2	3332 – 3339	31.2 – 31.8
12.51975 – 12.52025	240 – 285	3345.8 – 3358	36.43 – 36.5
12.57675 – 12.57725	322 – 335.4	3600 – 4400	
13.36 – 13.41			

## Restricted Bands of operation for IC

0.090 - 0.110	13.36 - 13.41	960 - 1427	9.0 - 9.2
0.495 - 0.505	16.42 - 16.423	1435 - 1626.5	9.3 - 9.5
2.1735 - 2.1905	16.69475 - 16.69525	1645.5 - 1646.5	10.6 - 12.7
3.020 - 3.026	16.80425 - 16.80475	1660 - 1710	13.25 - 13.4
4.125 - 4.128	25.5 - 25.67	1718.8 - 1722.2	14.47 - 14.5
4.17725 - 4.17775	37.5 - 38.25	2200 - 2300	15.35 - 16.2
4.20725 - 4.20775	73 - 74.6	2310 - 2390	17.7 - 21.4
5.677 - 5.683	74.8 - 75.2	2483.5 - 2500	22.01 - 23.12
6.215 - 6.218	108 - 138	2655 - 2900	23.6 - 24.0
6.26775 - 6.26825	149.9 - 150.05	3260 - 3267	31.2 - 31.8
6.31175 - 6.31225	156.52475 - 156.52525	3332 - 3339	36.43 - 36.5
8.291 - 8.294	156.7 - 156.9	3345.8 - 3358	Above 38.6
8.362 - 8.366	162.0125 - 167.17	3500 - 4400	
8.37625 - 8.38675	167.72 - 173.2	4500 - 5150	
8.41425 - 8.41475	240 - 285	5350 - 5460	
12.29 - 12.293	322 - 335.4	7250 - 7750	
12.51975 - 12.52025	399.9 - 410	8025 - 8500	
12.57675 - 12.57725	608 - 614	--	

Restricted Band Emissions Limit			
Frequency (MHz)	Field strength ( $\mu\text{V/m}$ )	Field strength ( $\text{dB}\mu\text{V/m}$ )	Measurement distance (m)
0.009 - 0.49	2400/F(kHz)	48.5 – 13.8	300 <sub>(Note 1)</sub>
0.49 - 1.705	24000/F(kHz)	33.8 - 23	30 <sub>(Note 1)</sub>
1.705 - 30	30	29.5	30 <sub>(Note 1)</sub>
30 - 88	100	40	3 <sub>(Note 2)</sub>
88 - 216	150	43.5	3 <sub>(Note 2)</sub>
216 - 960	200	46	3 <sub>(Note 2)</sub>
Above 960	500	54	3 <sub>(Note 2)</sub>

Note 1: At frequencies below 30 MHz, measurements may be performed at a distance closer than that specified in the regulations; however, an attempt should be made to avoid making measurements in the near field. Pending the development of an appropriate measurement procedure for measurements performed below 30 MHz, when performing measurements at a closer distance than specified, the results shall be extrapolated to the specified distance by either making measurements at a minimum of two distances on at least one radial to determine the proper extrapolation factor or by using the square of an inverse linear distance extrapolation factor (40 dB/decade).

Note 2: At frequencies at or above 30 MHz, measurements may be performed at a distance other than what is specified provided: measurements are not made in the near field except where it can be shown that near field measurements are appropriate due to the characteristics of the device; and it can be demonstrated that the signal levels needed to be measured at the distance employed can be detected by the measurement equipment.

Measurements shall not be performed at a distance greater than 30 meters unless it can be further demonstrated that measurements at a distance of 30 meters or less are impractical. When performing measurements at a distance other than that specified, the results shall be extrapolated to the specified distance using an extrapolation factor of 20 dB/decade (inverse linear-distance for field strength measurements; inverse-linear-distance-squared for power density measurements).

### 4.2.2 Test Setup

30MHz-1GHz Test Setup:

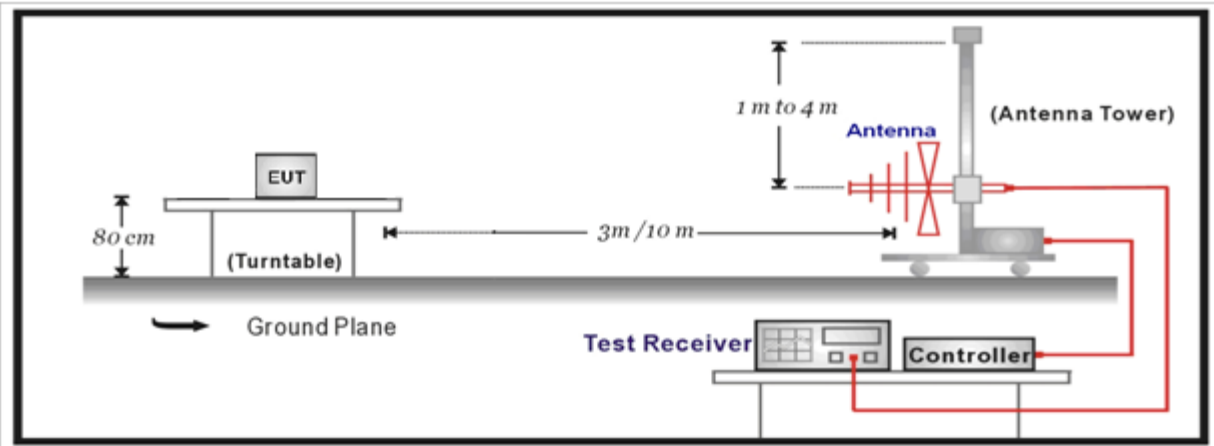

Above 1GHz Test Setup:

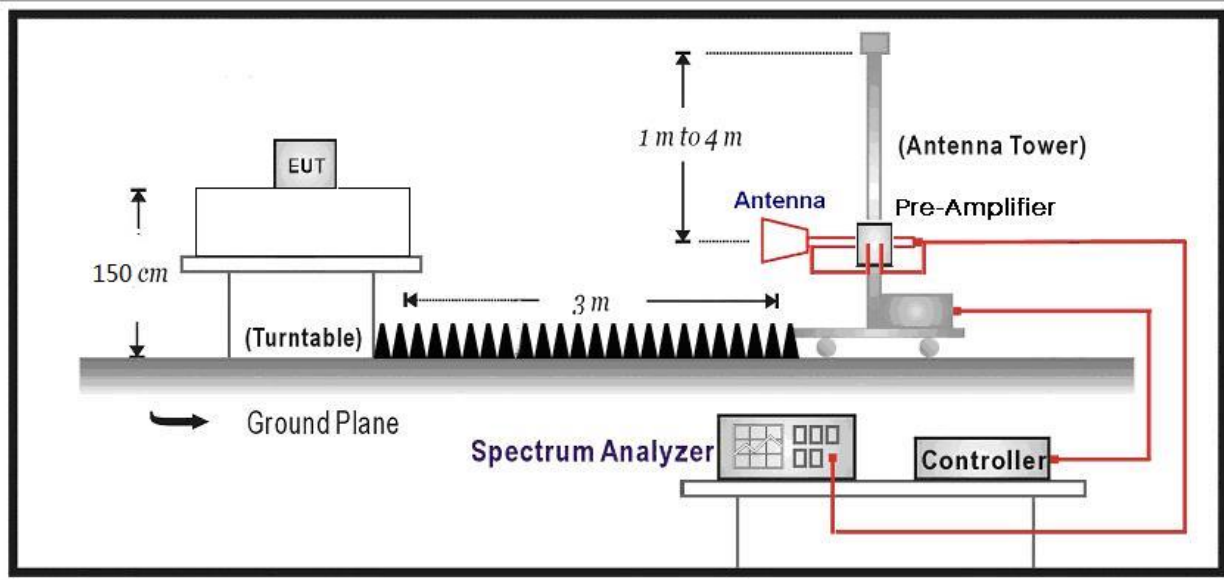

### 4.2.3 Test Procedure

References Rule	Chapter	Description
<input checked="" type="checkbox"/> ANSI C63.10	11.12	Emissions in restricted frequency bands
<input checked="" type="checkbox"/> ANSI C63.10	11.12.1	Radiated emission measurements
<input checked="" type="checkbox"/> ANSI C63.10	11.12.2.7	Radiated spurious emission test
<input checked="" type="checkbox"/> ANSI C63.10	6.4	Radiated emissions from unlicensed wireless devices below 30 MHz
<input checked="" type="checkbox"/> ANSI C63.10	6.5	Radiated emissions from unlicensed wireless devices in the frequency range of 30 MHz to 1000 MHz
<input checked="" type="checkbox"/> ANSI C63.10	6.6	Radiated emissions from unlicensed wireless devices above 1 GHz



**4.2.4 Test Data**

Profile: 2150995R	Page No.: 7
Engineer: Yu Liu	
Site: AC5	Time: 2021/06/23 - 09:59
Limit: FCC_Part15.209_RE(3m)	Margin: 0
Probe: Horn_3117_00167055(1-18GHz)	Polarity: Vertical
EUT: Wireless Headset	Power: Battery
Note: Mode 1:Transmit at 2405.35MHz	

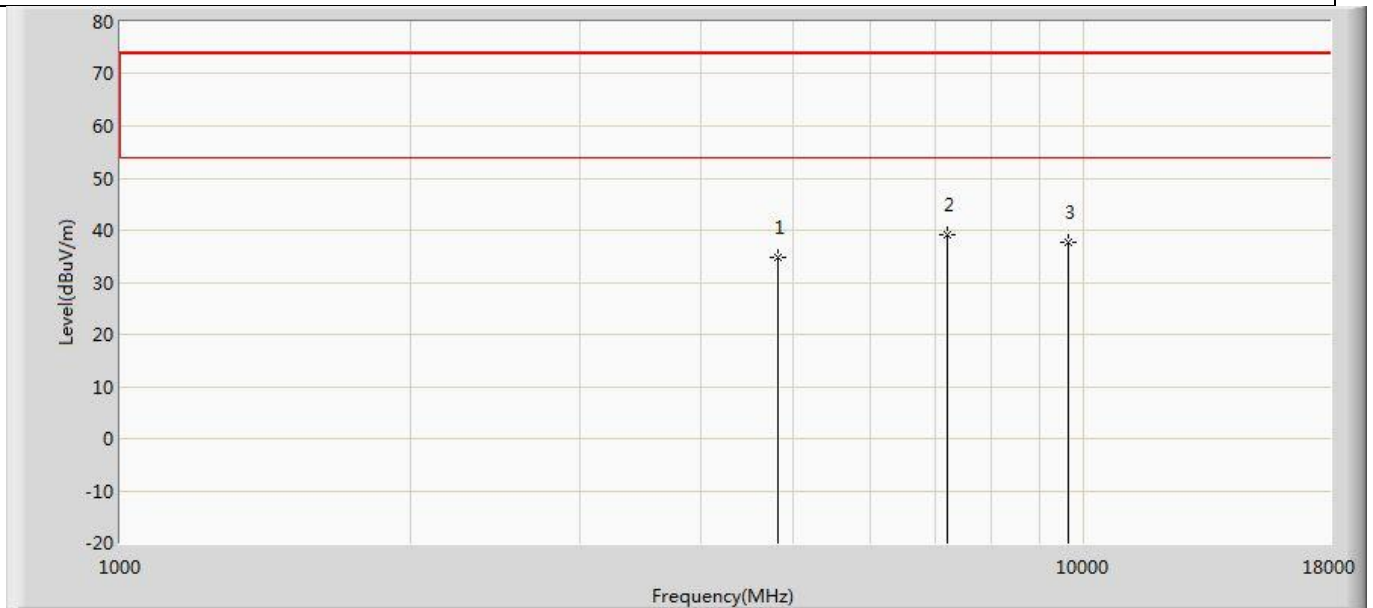

No	Mark	Frequency (MHz)	Measure Level (dBuV/m)	Reading Level (dBuV)	Over Limit (dB)	Limit (dBuV/m)	Factor (dB)	Type
1		4810.700	34.894	41.316	-39.106	74.000	-6.422	PK
2	*	7216.050	39.112	41.700	-34.888	74.000	-2.588	PK
3		9621.400	37.636	39.025	-36.364	74.000	-1.388	PK

Profile: 2150995R	Page No.: 8
Engineer: Yu Liu	
Site: AC5	Time: 2021/06/23 - 09:59
Limit: FCC_Part15.209_RE(3m)	Margin: 0
Probe: Horn_3117_00167055(1-18GHz)	Polarity: Horizontal
EUT: Wireless Headset	Power: Battery
Note: Mode 1:Transmit at 2405.35MHz	

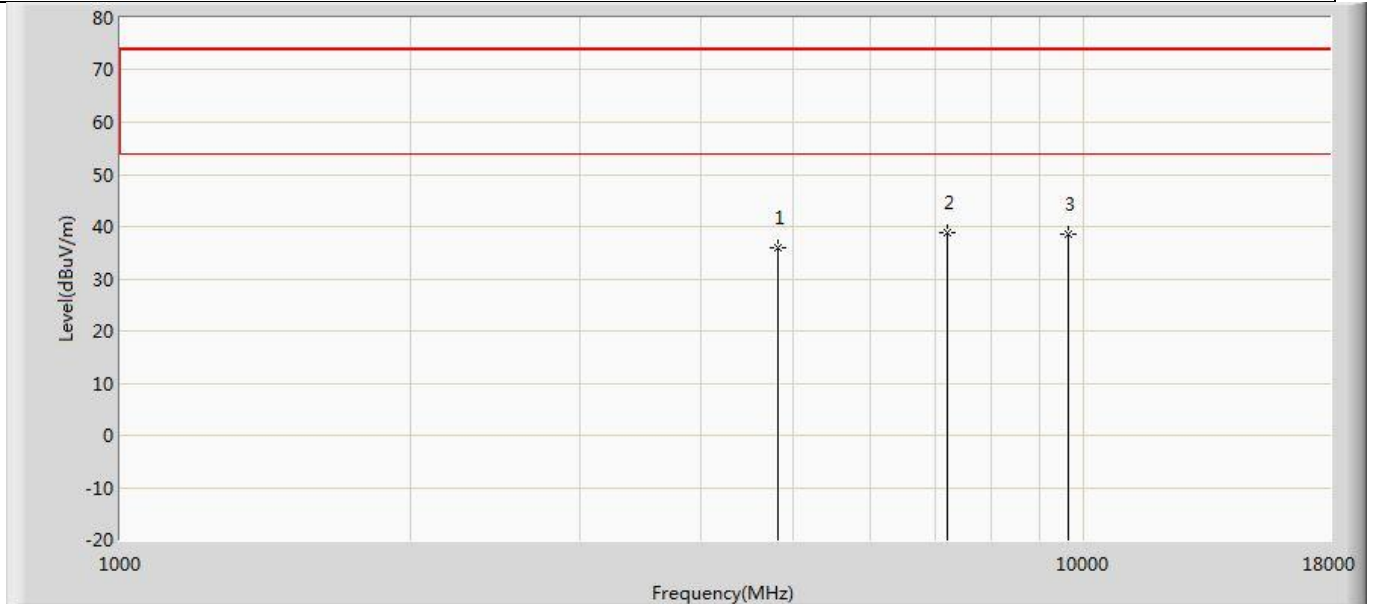

No	Mark	Frequency (MHz)	Measure Level (dBuV/m)	Reading Level (dBuV)	Over Limit (dB)	Limit (dBuV/m)	Factor (dB)	Type
1		4810.700	35.982	42.404	-38.018	74.000	-6.422	PK
2	*	7216.050	38.935	41.523	-35.065	74.000	-2.588	PK
3		9621.400	38.629	40.018	-35.371	74.000	-1.388	PK

Profile: 2150995R	Page No.: 9
Engineer: Yu Liu	
Site: AC5	Time: 2021/06/23 - 09:59
Limit: FCC_Part15.209_RE(3m)	Margin: 0
Probe: Horn_3117_00167055(1-18GHz)	Polarity: Vertical
EUT: Wireless Headset	Power: Battery
Note: Mode 1:Transmit at 2441.35MHz	

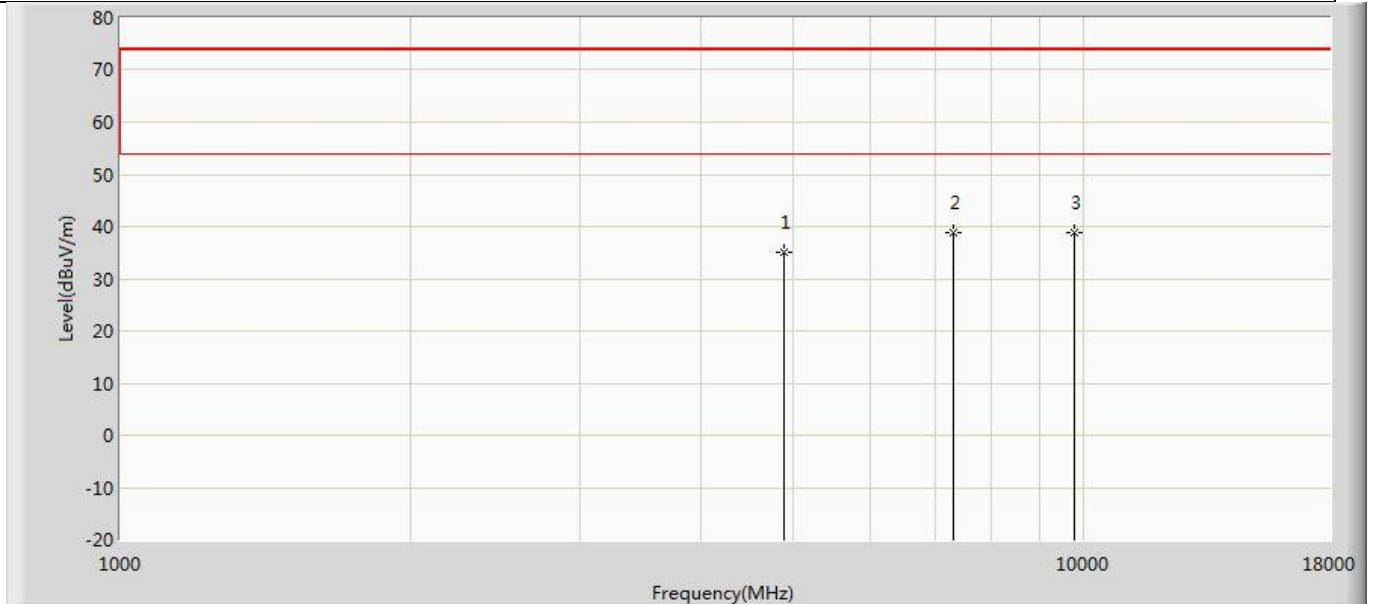

No	Mark	Frequency (MHz)	Measure Level (dBuV/m)	Reading Level (dBuV)	Over Limit (dB)	Limit (dBuV/m)	Factor (dB)	Type
1		4882.700	35.060	41.426	-38.940	74.000	-6.365	PK
2		7324.050	38.708	41.239	-35.292	74.000	-2.531	PK
3	*	9765.400	38.849	39.352	-35.151	74.000	-0.504	PK

Profile: 2150995R	Page No.: 10
Engineer: Yu Liu	
Site: AC5	Time: 2021/06/23 - 10:00
Limit: FCC_Part15.209_RE(3m)	Margin: 0
Probe: Horn_3117_00167055(1-18GHz)	Polarity: Horizontal
EUT: Wireless Headset	Power: Battery
Note: Mode 1:Transmit at 2441.35MHz	

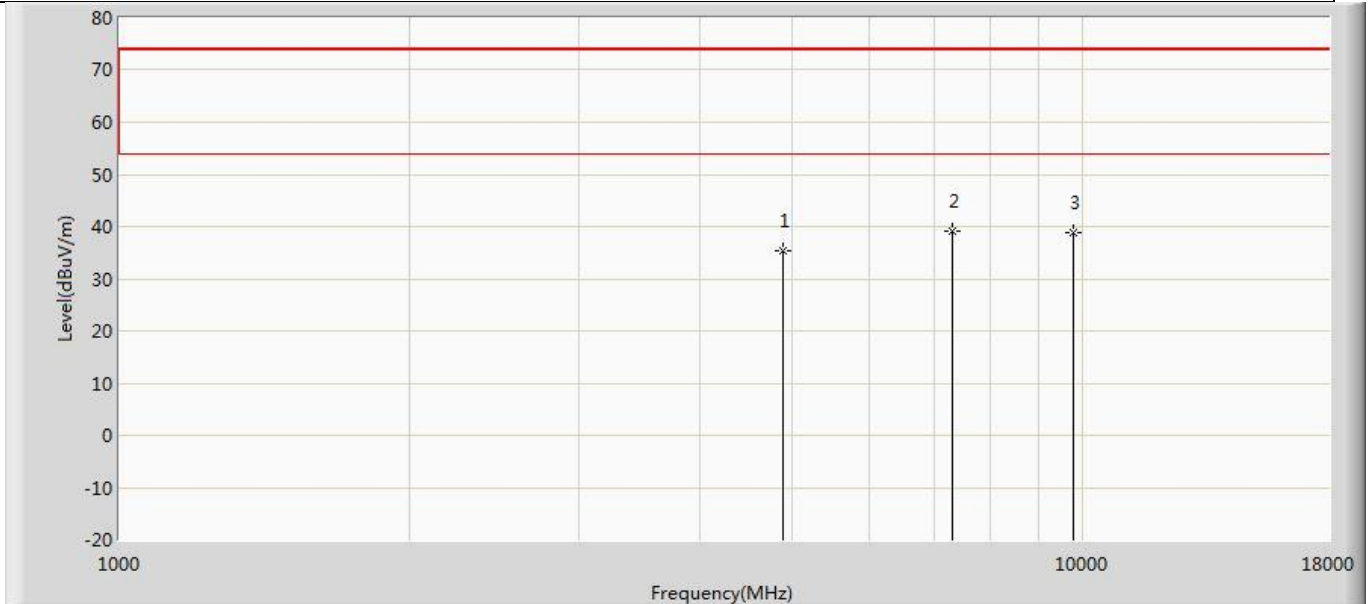

No	Mark	Frequency (MHz)	Measure Level (dBuV/m)	Reading Level (dBuV)	Over Limit (dB)	Limit (dBuV/m)	Factor (dB)	Type
1		4882.700	35.263	41.629	-38.737	74.000	-6.365	PK
2	*	7324.050	39.001	41.532	-34.999	74.000	-2.531	PK
3		9765.400	38.949	39.452	-35.051	74.000	-0.504	PK

Profile: 2150995R	Page No.: 11
Engineer: Yu Liu	
Site: AC5	Time: 2021/06/23 - 10:00
Limit: FCC_Part15.209_RE(3m)	Margin: 0
Probe: Horn_3117_00167055(1-18GHz)	Polarity: Vertical
EUT: Wireless Headset	Power: Battery
Note: Mode 1:Transmit at 2477.35MHz	

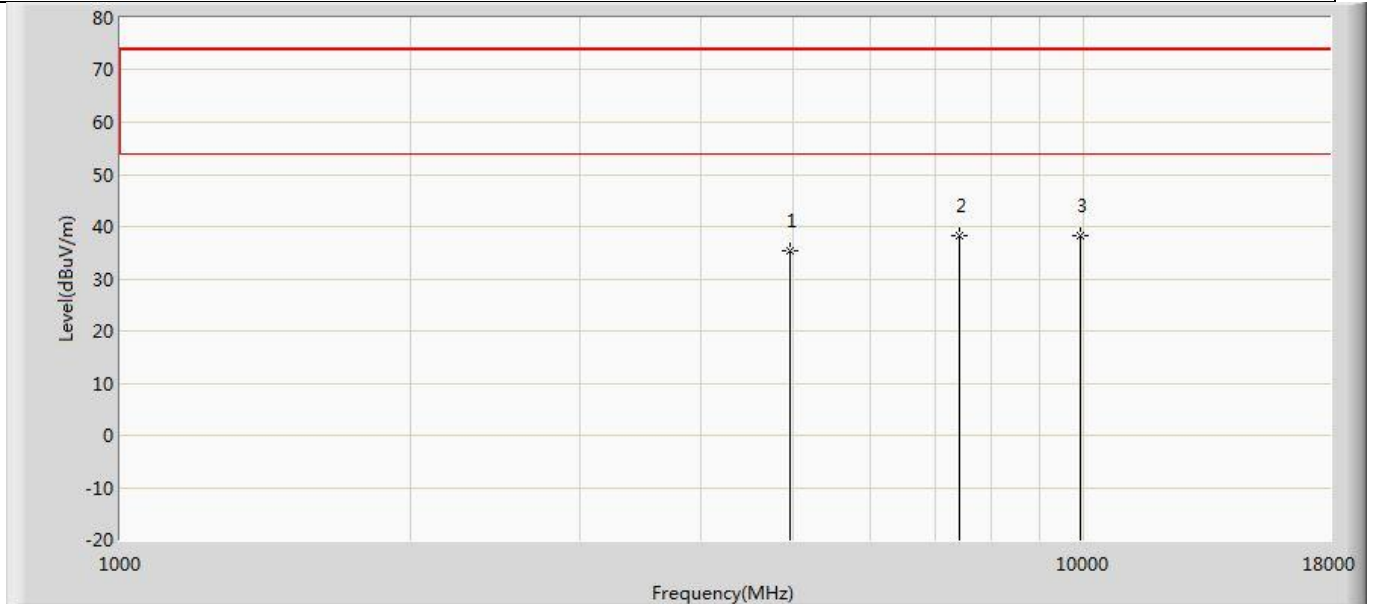

No	Mark	Frequency (MHz)	Measure Level (dBuV/m)	Reading Level (dBuV)	Over Limit (dB)	Limit (dBuV/m)	Factor (dB)	Type
1		4954.700	35.220	41.483	-38.780	74.000	-6.263	PK
2	*	7432.050	38.389	41.219	-35.611	74.000	-2.830	PK
3		9909.400	38.384	38.941	-35.616	74.000	-0.556	PK

Profile: 2150995R	Page No.: 12
Engineer: Yu Liu	
Site: AC5	Time: 2021/06/23 - 10:00
Limit: FCC_Part15.209_RE(3m)	Margin: 0
Probe: Horn_3117_00167055(1-18GHz)	Polarity: Horizontal
EUT: Wireless Headset	Power: Battery
Note: Mode 1:Transmit at 2477.35MHz	

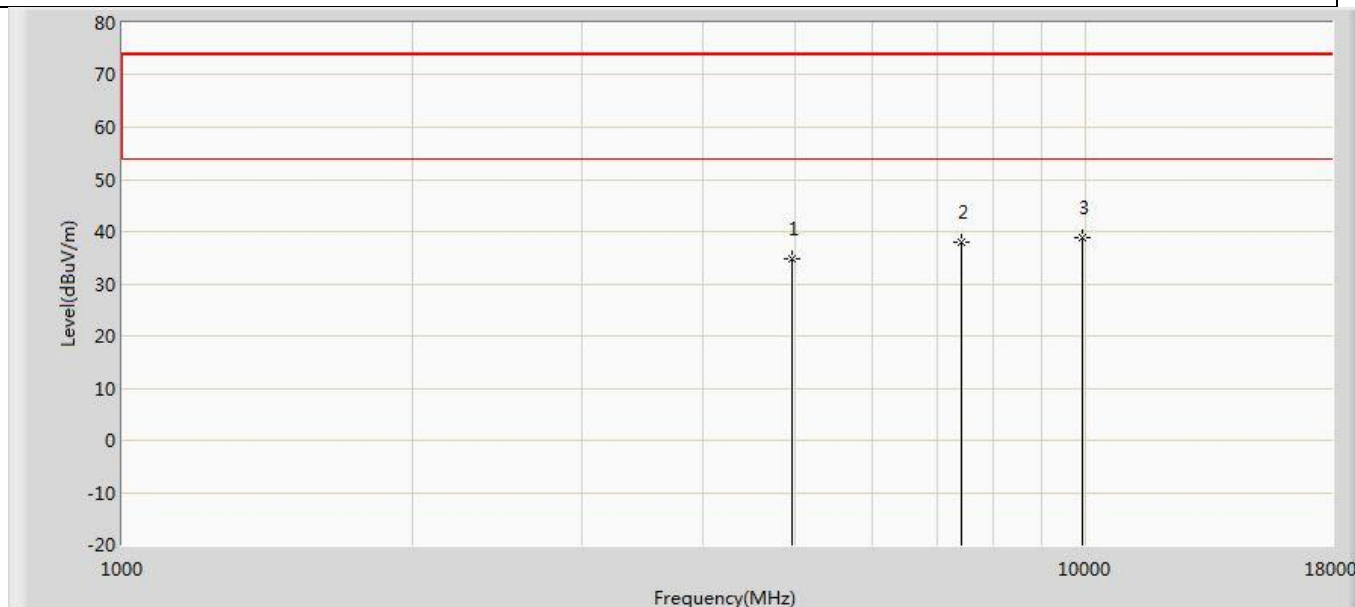

No	Mark	Frequency (MHz)	Measure Level (dBuV/m)	Reading Level (dBuV)	Over Limit (dB)	Limit (dBuV/m)	Factor (dB)	Type
1		4954.700	34.912	41.175	-39.088	74.000	-6.263	PK
2		7432.050	38.046	40.876	-35.954	74.000	-2.830	PK
3	*	9909.400	38.712	39.269	-35.288	74.000	-0.556	PK

Note:

1. Measured Level = Reading Level + Factor.
2. The test frequency range, 9kHz~30MHz, 18GHz~26GHz, both of the worst case are at least 20dB below the limits, therefore no data appear in the report.
3. This limit applies for using average detector, if the test result on peak is lower than average limit, then average measurement needn't be performed.
4. As the radiated emission was performed, so conducted emission was not tested.

**The worst case of Radiated Emission below 1GHz:**

Profile: 2150995R	Page No.: 13
Engineer: Yu Liu	
Site: AC2	Time: 2021/06/23 - 02:04
Limit: FCC_Part15.209_RE(3m)	Margin: 0
Probe: AC2_3M(30-1000M)	Polarity: Horizontal
EUT: Wireless Headset	Power: Battery
Note: Mode 1:	

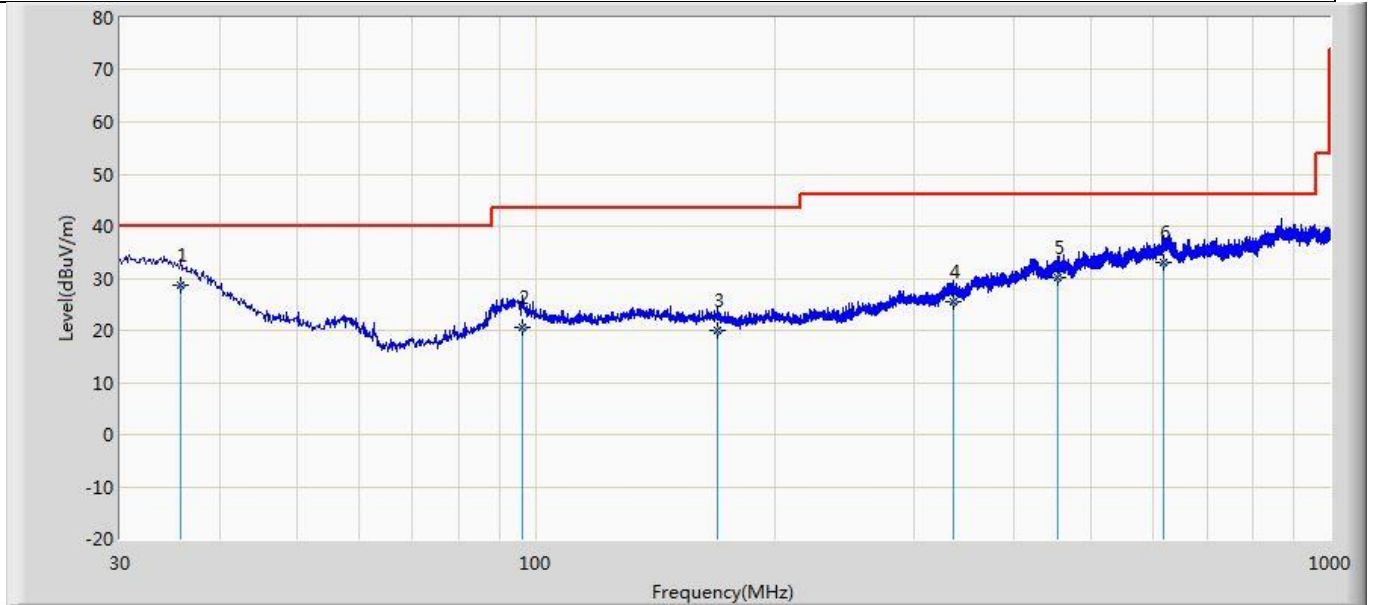

No	Mark	Frequency (MHz)	Measure Level (dBuV/m)	Reading Level (dBuV)	Over Limit (dB)	Limit (dBuV/m)	Factor (dB)	Ant Pos (cm)	Table Pos (deg)	Type
1	*	35.820	28.554	2.326	-11.446	40.000	26.228	100	157	QP
2		96.445	20.689	5.150	-22.811	43.500	15.539	200	271	QP
3		169.801	19.954	2.784	-23.546	43.500	17.170	100	92	QP
4		336.277	25.405	2.690	-20.595	46.000	22.714	100	315	QP
5		454.254	30.275	3.048	-15.725	46.000	27.227	200	121	QP
6		618.062	33.025	2.652	-12.975	46.000	30.373	200	234	QP

Profile: 2150995R	Page No.: 14
Engineer: Yu Liu	
Site: AC2	Time: 2021/06/23 - 02:07
Limit: FCC_Part15.209_RE(3m)	Margin: 0
Probe: AC2_3M(30-1000M)	Polarity: Vertical
EUT: Wireless Headset	Power: Battery
Note: Mode 1:	

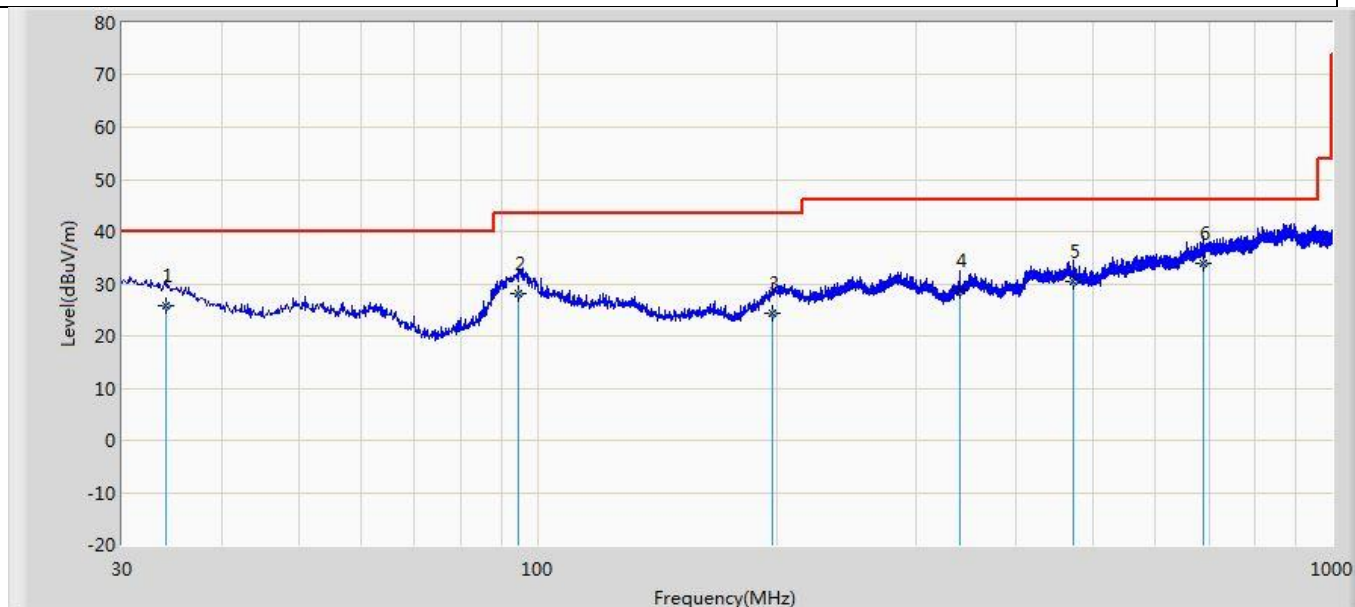

No	Mark	Frequency (MHz)	Measure Level (dBuV/m)	Reading Level (dBuV)	Over Limit (dB)	Limit (dBuV/m)	Factor (dB)	Ant Pos (cm)	Table Pos (deg)	Type
1		34.123	25.673	2.868	-14.327	40.000	22.805	200	237	QP
2		94.626	28.074	8.460	-15.426	43.500	19.613	100	182	QP
3		197.325	24.486	1.736	-19.014	43.500	22.750	200	304	QP
4		339.551	28.571	5.000	-17.429	46.000	23.572	200	76	QP
5		471.956	30.571	4.083	-15.429	46.000	26.487	100	115	QP
6	*	687.539	33.958	3.942	-12.042	46.000	30.016	100	259	QP

Note:

1. All Readings below 1GHz are Quasi-Peak, above are performed with peak and/or average measurements as necessary.
2. " \* ", means this data is the worst emission level.
3. Measurement Level = Reading Level + Factor(Probe+Cable-Amp).



<b>4.3 Emissions in non-restricted frequency band</b>	<b>VERDICT: PASS</b>
---	----------------------

<b>4.3.1 Limit</b>	
<b>Standard</b>	FCC Part 15 Subpart C Paragraph 15.247(d)
RF Output power (Detection methods)	Limit(dB)
RF Output power(Average detector)	30dBc(Note1)
RF Output power(PK detector)	20dBc(Note2)
<p>Note 1: If maximum conducted (average) output power was used to demonstrate compliance as described in 9.2, then the peak power in any 100 kHz bandwidth outside of the authorized frequency band shall be attenuated by at least 30 dB relative to the maximum in-band peak PSD level in 100 kHz (i.e., 30 dBc).</p> <p>Note 2: If the maximum peak conducted output power procedure was used, then the peak output power measured in any 100 kHz bandwidth outside of the authorized frequency band shall be attenuated by at least 20 dB relative to the maximum in-band peak PSD level in 100 kHz (i.e., 20 dBc).</p>	

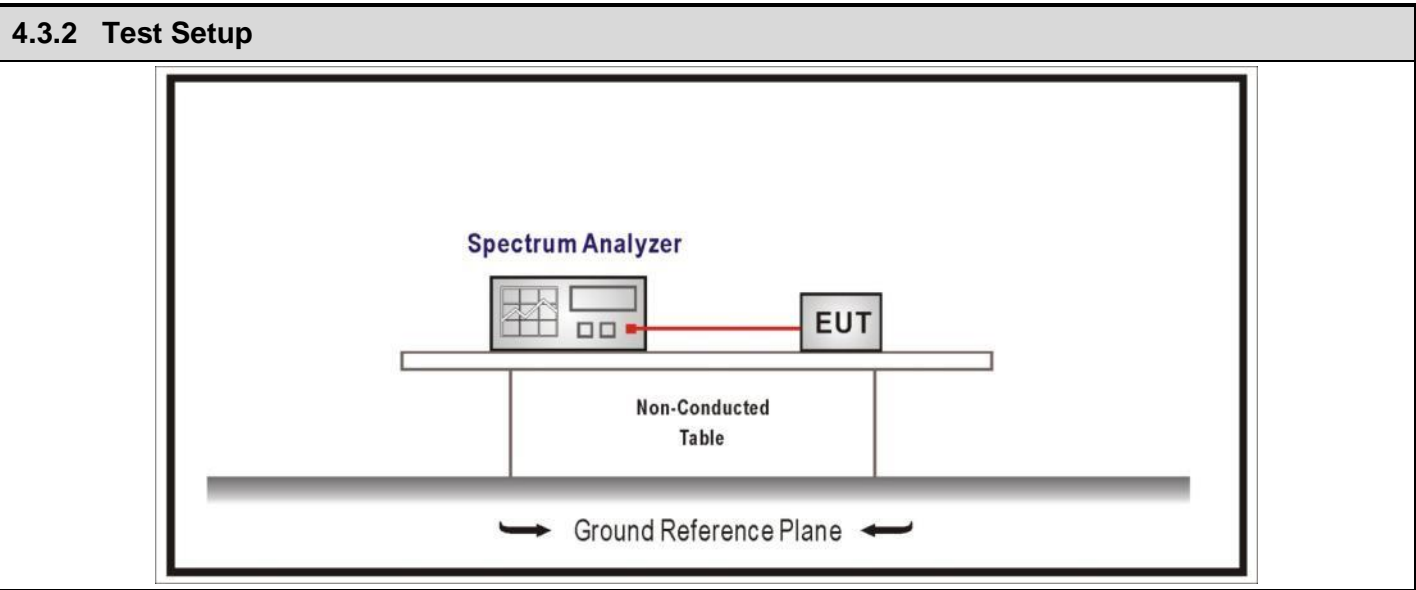

<b>4.3.3 Test Procedure</b>			
References Rule	Chapter	Description	
<input checked="" type="checkbox"/>	ANSI C63.10	11.11	Emissions in non-restricted frequency bands
<input checked="" type="checkbox"/>	ANSI C63.10	11.11.1	General
<input checked="" type="checkbox"/>	ANSI C63.10	11.11.2	Reference level measurement
<input checked="" type="checkbox"/>	ANSI C63.10	11.11.3	Emission level measurement

### 4.3.4 Test Data

Mode	Channel	Test Frequency (MHz)	Maximum In-Band PSD[a] (dBm/100kHz)	Frequency (MHz)	Out-Band PSD[b] (dBm/100kHz)	[a]-[b] (dB)	Limit (dB)	Result
1	02	2405.35	-1.863	2500	-41.440	39.577	>20	Pass
	38	2477.35	-3.492	2500	-55.005	51.513	>20	Pass

Note 1: The worst data plot as below:

Mode1/CH02/2405.35MHz

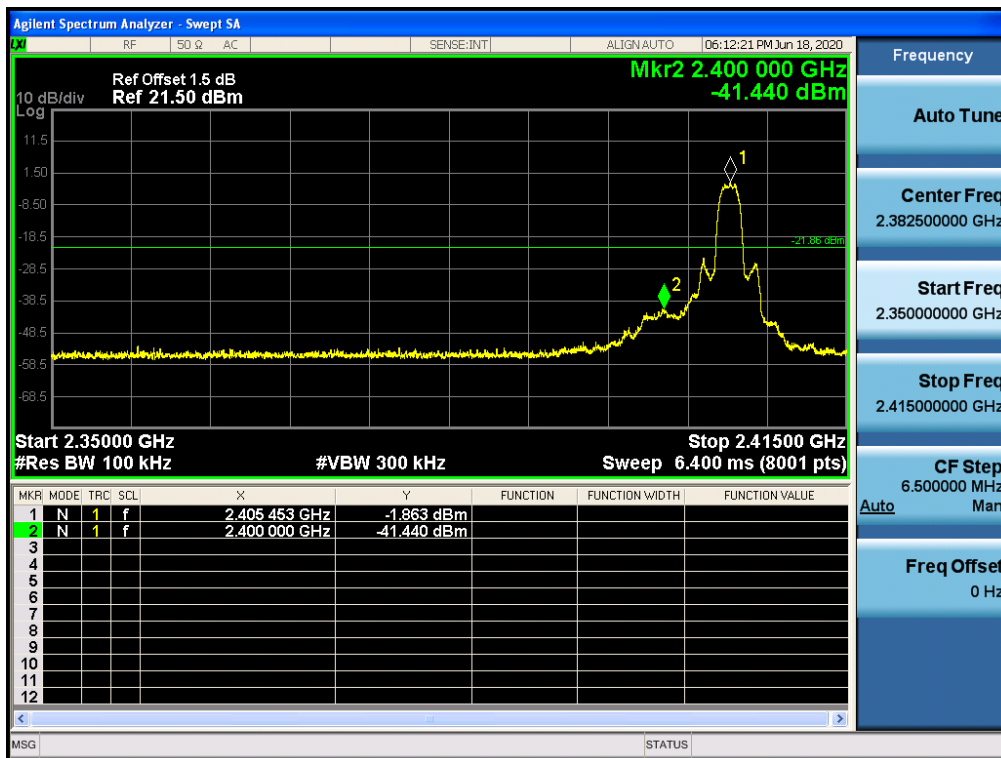

**4.4 Duty cycle**

**VERDICT: PASS**

**4.4.1 Limit**

N/A

**4.4.2 Test Setup**

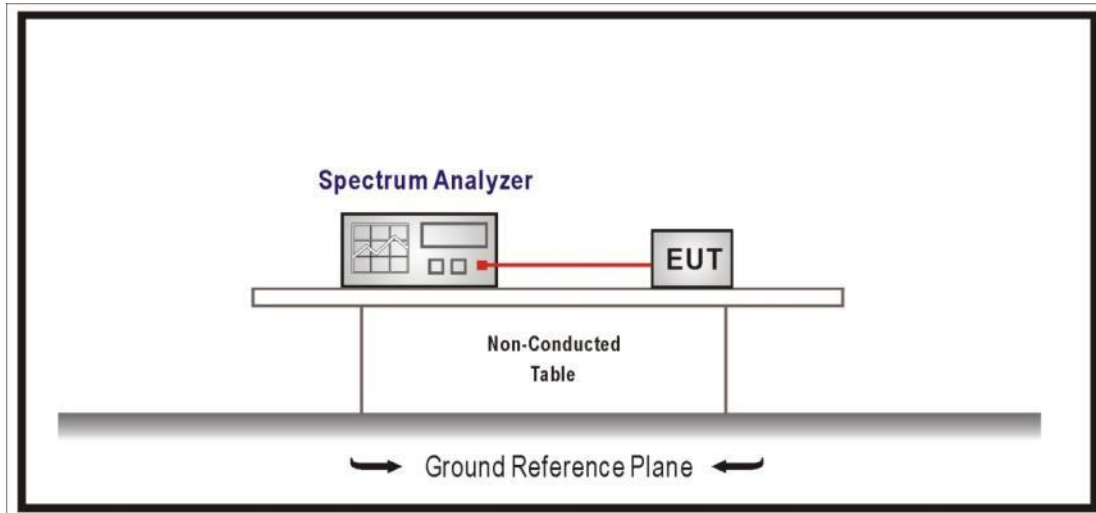

**4.4.3 Test Procedure**

References Rule	Chapter	Description
<input checked="" type="checkbox"/> ANSI C63.10	11.6	Duty cycle (D), transmission duration (T), and maximum power control level

**4.4.4 Test Data**

Test Mode	Tx On (us)	Tx Off (us)	VBW (kHz)	Tx On + Tx Off (us)	Duty Cycle (%)
Mode 1	--	--	--	--	100

Note 1: T means the minimum transmission duration over which the transmitter is on and is transmitting at its maximum power control level for the tested mode of operation.

Note 2: According to KDB 558074, when test for Radiated Emission Band Edge and Radiated Emission, for average detector set:  $VBW \geq 1/T$  will be used.

Mode 1 CH02 2405.35MHz

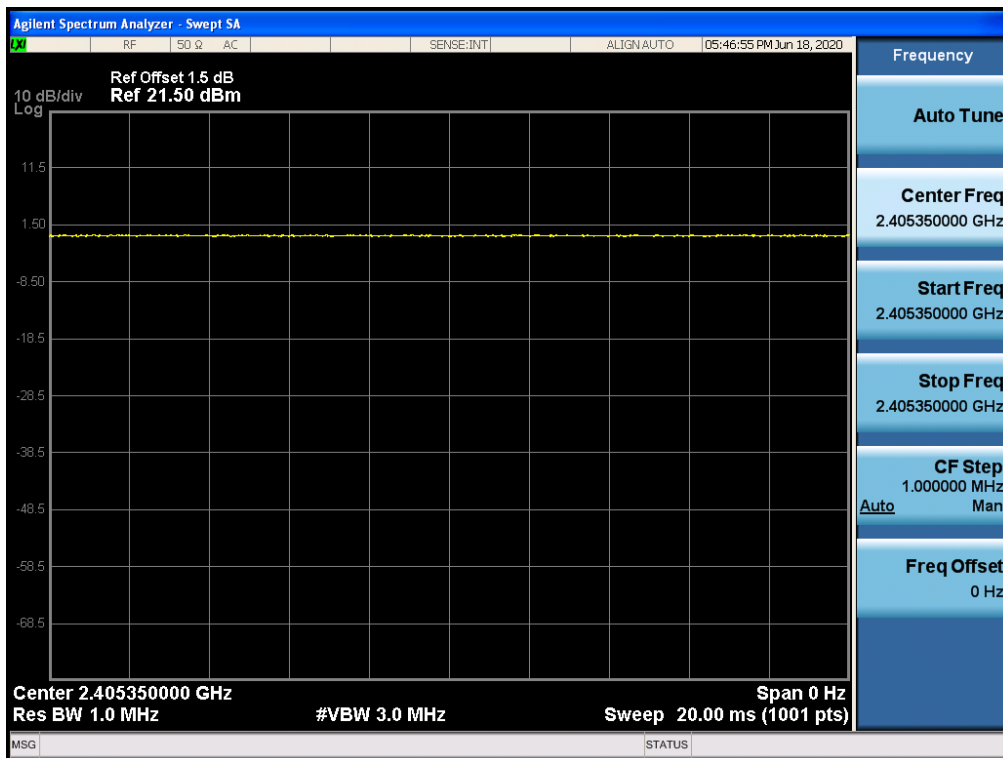

**4.5 Radiated Emission Band Edge**

**VERDICT: PASS**

**4.5.1 Limit**

<b>Standard</b>		FCC Part 15 Subpart C Paragraph 15.247(d) , 15.209		
Frequency bands (MHz)	Detector	Limit (dBµV/m)	RBW (MHz)	Distance (m)
2310-2390	PK	74	1	3
2483.5-2500	AV	54	1	3

Note: The field strength of emissions appearing within these frequency bands shall not exceed the limits.

**4.5.2 Test Setup**

Above 1GHz Test Setup:

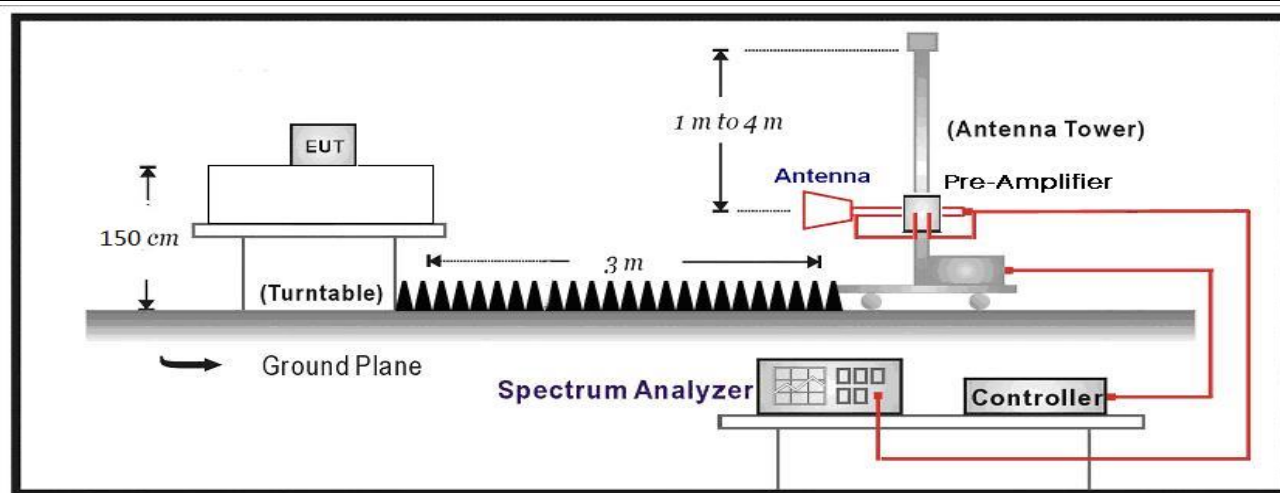

**4.5.3 Test Procedure**

	References Rule	Chapter	Description
<input checked="" type="checkbox"/>	ANSI C63.10	6.10	Band-edge testing
	<input checked="" type="checkbox"/> ANSI C63.10	6.10.5	Restricted-band band-edge measurements
	<input type="checkbox"/> ANSI C63.10	6.10.6	Marker-delta method
<input checked="" type="checkbox"/>	ANSI C63.10	11.12	Emissions in restricted frequency bands
	<input checked="" type="checkbox"/> ANSI C63.10	11.12.1	Radiated emission measurements
	<input checked="" type="checkbox"/> ANSI C63.10	11.12.2.7	Radiated spurious emission test
<input type="checkbox"/>	ANSI C63.10	6.4	Radiated emissions from unlicensed wireless devices below 30 MHz
<input type="checkbox"/>	ANSI C63.10	6.5	Radiated emissions from unlicensed wireless devices in the frequency range of 30 MHz to 1000 MHz
<input checked="" type="checkbox"/>	ANSI C63.10	6.6	Radiated emissions from unlicensed wireless devices above 1 GHz

**4.5.4 Test Data**

Profile: 2150995R	Page No.: 1
Engineer: YULIU	
Site: AC5	Time: 2020/03/12 - 00:39
Limit: FCC_Part15.209_RE(3m)	Margin: 0
Probe: Horn_3117_00167055(1-18GHz)	Polarity: Vertical
EUT: Wireless Headset	Power: Battery
Note: Mode 1: Transmit at 2405.35MHz	

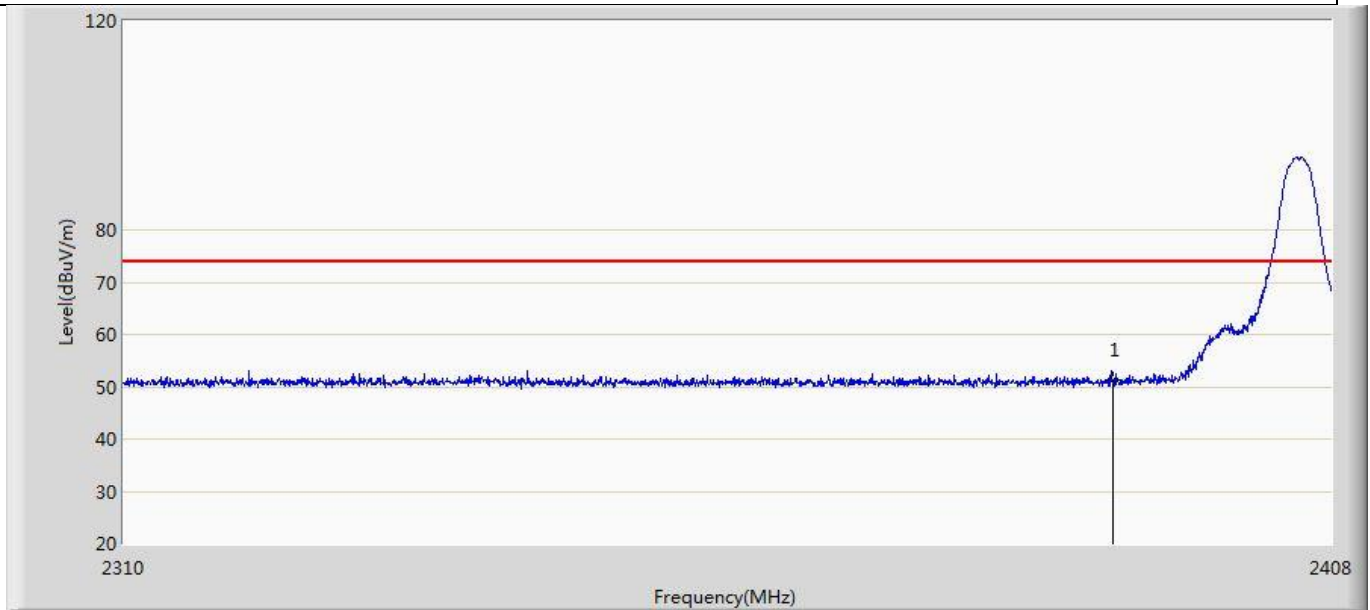

No	Mark	Frequency (MHz)	Measure Level (dBuV/m)	Reading Level (dBuV)	Over Limit (dB)	Limit (dBuV/m)	Factor (dB)	Type
1	*	2390.000	51.376	15.919	-22.624	74.000	35.458	PK

Profile: 2150995R	Page No.: 2
Engineer: YULIU	
Site: AC5	Time: 2021/06/22 - 21:38
Limit: FCC_Part15.209_RE(3m)	Margin: 0
Probe: Horn_3117_00167055(1-18GHz)	Polarity: Vertical
EUT: Wireless Headset	Power: Battery
Note: Mode 1:Transmit at 2405.35MHz	

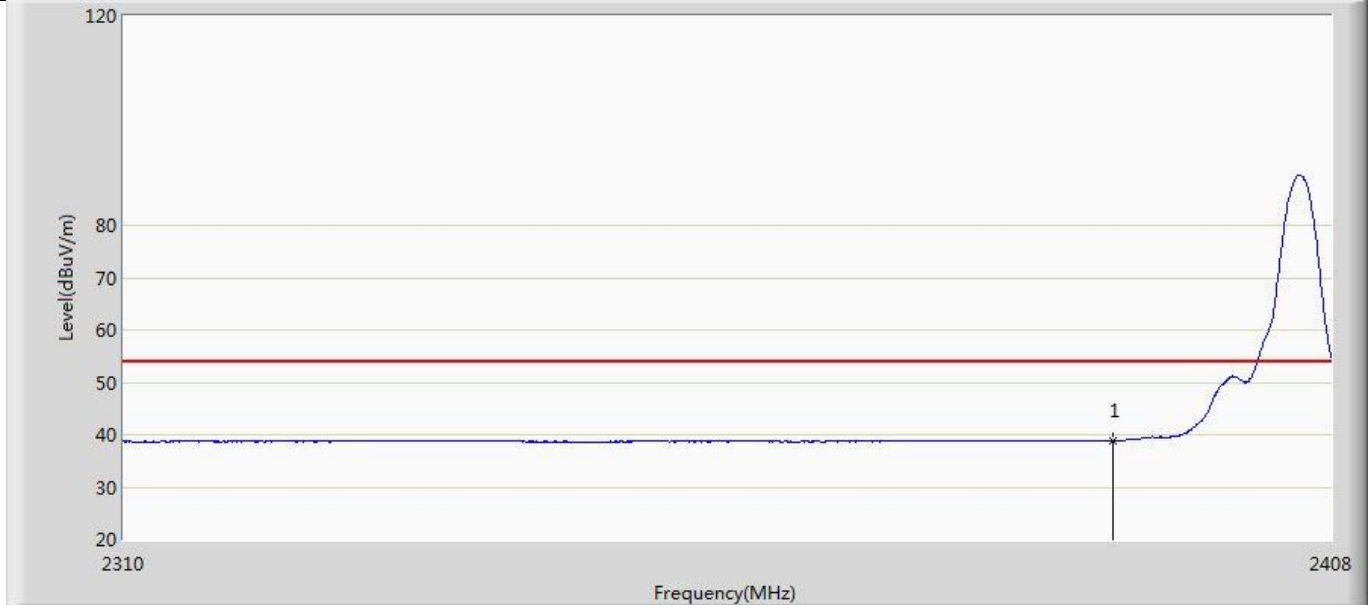

No	Mark	Frequency (MHz)	Measure Level (dBuV/m)	Reading Level (dBuV)	Over Limit (dB)	Limit (dBuV/m)	Factor (dB)	Type
1	*	2390.000	38.891	3.434	-15.109	54.000	35.458	AV

Profile: 2150995R	Page No.: 3
Engineer: YULIU	
Site: AC5	Time: 2021/06/22 - 21:41
Limit: FCC_Part15.209_RE(3m)	Margin: 0
Probe: Horn_3117_00167055(1-18GHz)	Polarity: Horizontal
EUT: Wireless Headset	Power: Battery
Note: Mode 1:Transmit at 2405.35MHz	

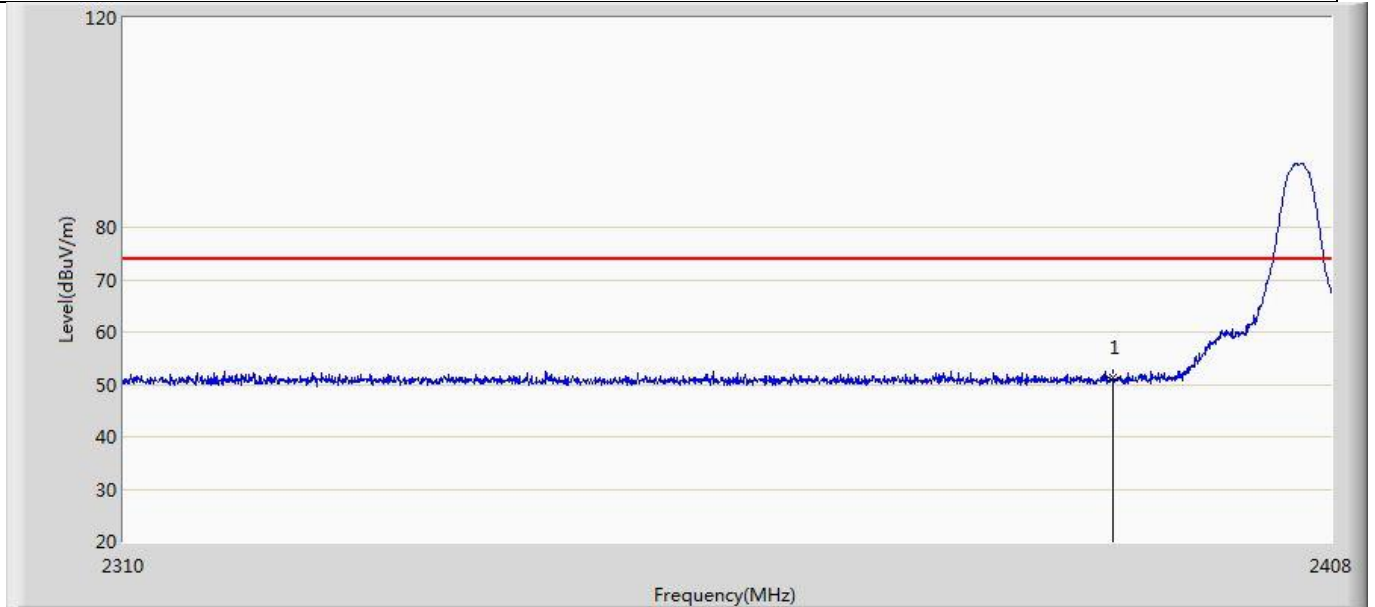

No	Mark	Frequency (MHz)	Measure Level (dBuV/m)	Reading Level (dBuV)	Over Limit (dB)	Limit (dBuV/m)	Factor (dB)	Type
1	*	2390.000	51.215	15.758	-22.785	74.000	35.458	PK



Profile: 2150995R	Page No.: 4
Engineer: YULIU	
Site: AC5	Time: 2021/06/22 - 21:43
Limit: FCC_Part15.209_RE(3m)	Margin: 0
Probe: Horn_3117_00167055(1-18GHz)	Polarity: Horizontal
EUT: Wireless Headset	Power: Battery
Note: Mode 1:Transmit at 2405.35MHz	

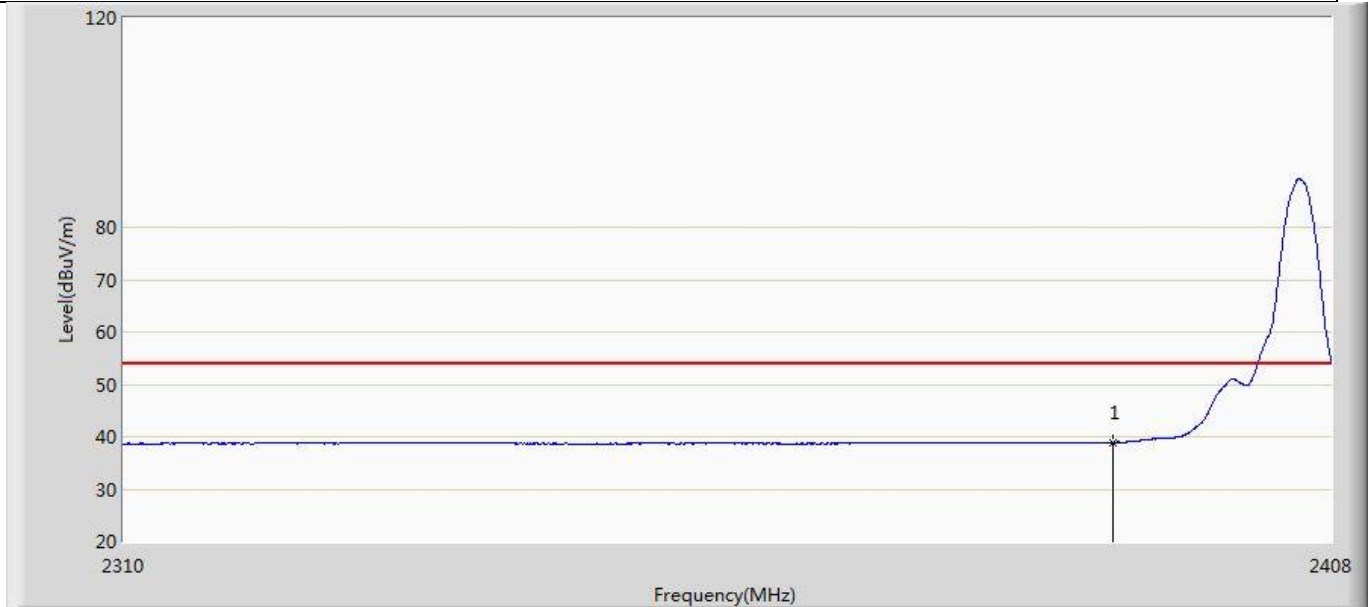

No	Mark	Frequency (MHz)	Measure Level (dBuV/m)	Reading Level (dBuV)	Over Limit (dB)	Limit (dBuV/m)	Factor (dB)	Type
1	*	2390.000	38.893	3.436	-15.107	54.000	35.458	AV

Profile: 2150995R	Page No.: 5
Engineer: YULIU	
Site: AC5	Time: 2021/06/22 - 21:50
Limit: FCC_Part15.209_RE(3m)	Margin: 0
Probe: Horn_3117_00167055(1-18GHz)	Polarity: Vertical
EUT: Wireless Headset	Power: Battery
Note: Mode 1:Transmit at 2477.35MHz	

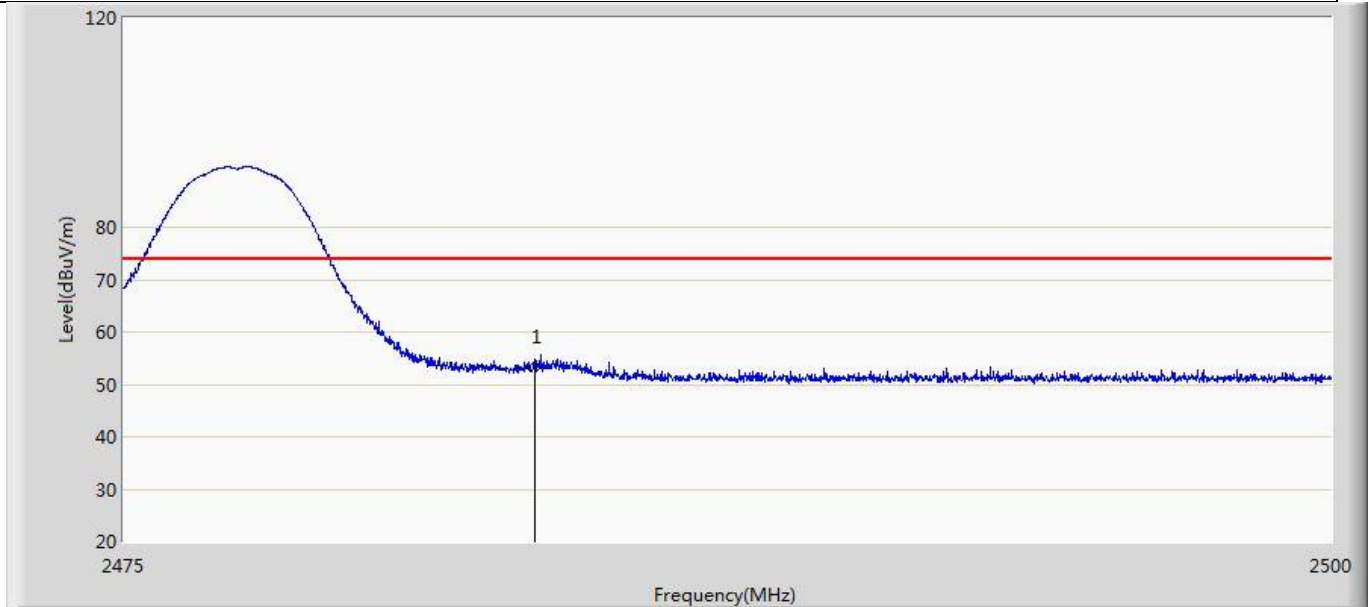

No	Mark	Frequency (MHz)	Measure Level (dBuV/m)	Reading Level (dBuV)	Over Limit (dB)	Limit (dBuV/m)	Factor (dB)	Type
1	*	2483.500	53.267	17.749	-20.733	74.000	35.517	PK

Profile: 2150995R	Page No.: 6
Engineer: YULIU	
Site: AC5	Time: 2021/06/22 - 21:52
Limit: FCC_Part15.209_RE(3m)	Margin: 0
Probe: Horn_3117_00167055(1-18GHz)	Polarity: Vertical
EUT: Wireless Headset	Power: Battery
Note: Mode 1:Transmit at 2477.35MHz	

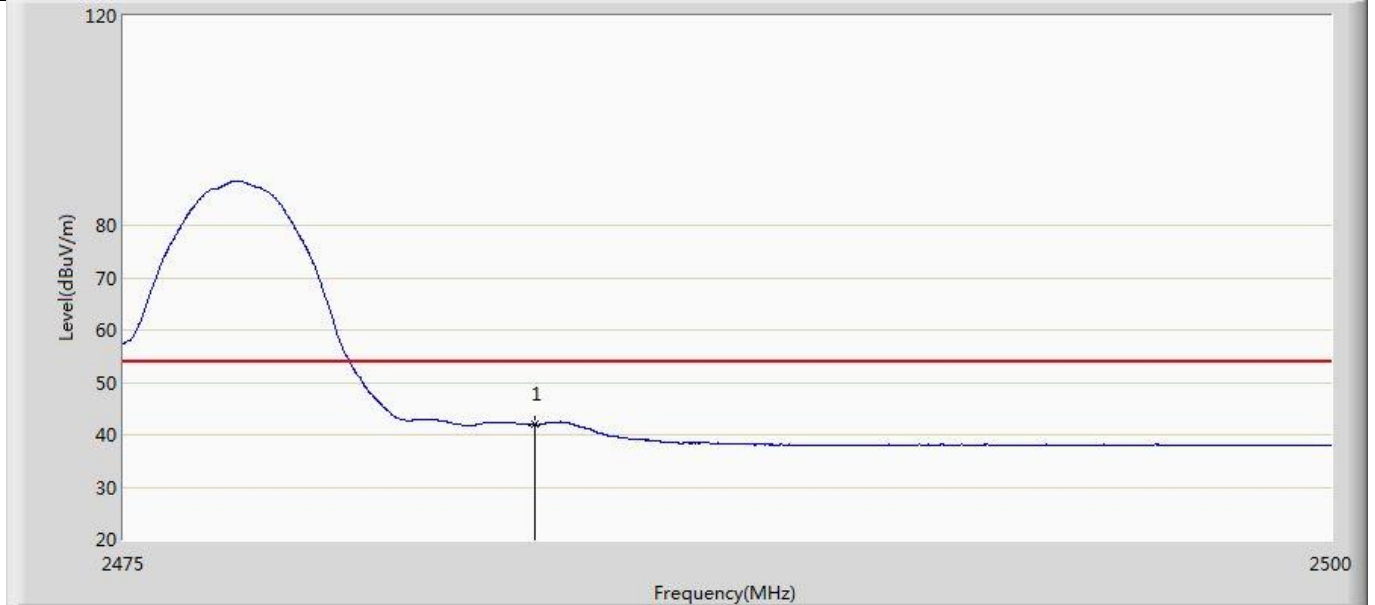

No	Mark	Frequency (MHz)	Measure Level (dBuV/m)	Reading Level (dBuV)	Over Limit (dB)	Limit (dBuV/m)	Factor (dB)	Type
1	*	2483.500	41.901	6.383	-12.099	54.000	35.517	AV

Profile: 2150995R	Page No.: 7
Engineer: YULIU	
Site: AC5	Time: 2021/06/22 - 21:54
Limit: FCC_Part15.209_RE(3m)	Margin: 0
Probe: Horn_3117_00167055(1-18GHz)	Polarity: Horizontal
EUT: Wireless Headset	Power: Battery
Note: Mode 1:Transmit at 2477.35MHz	

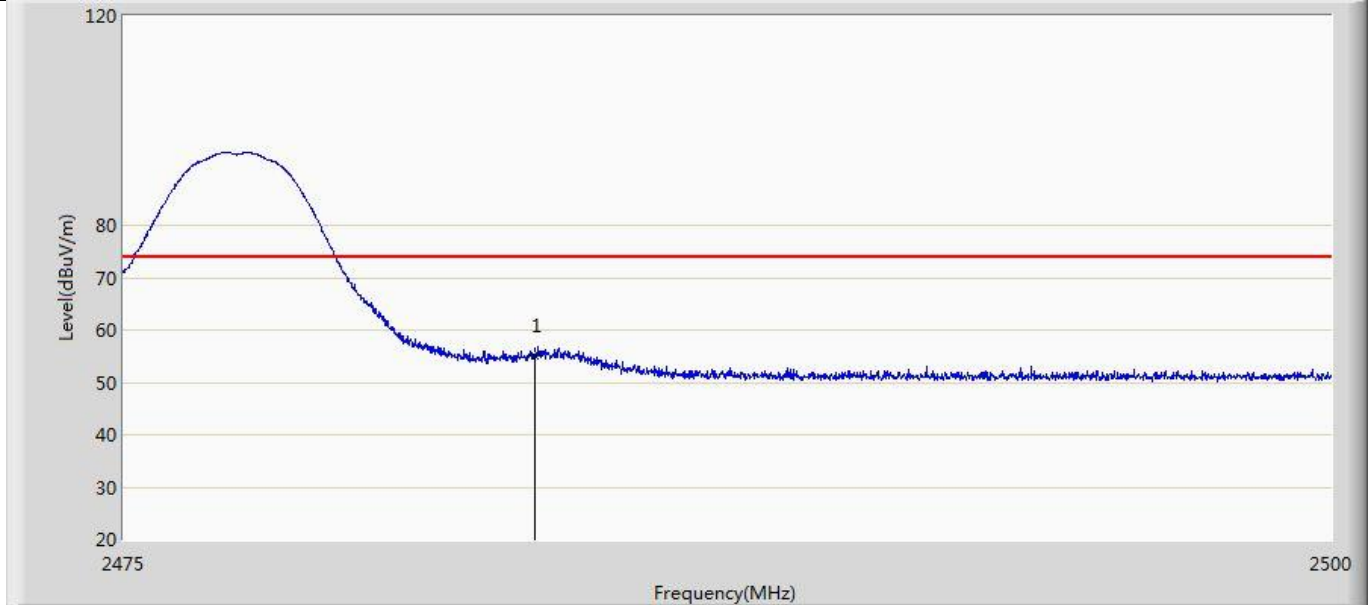

No	Mark	Frequency (MHz)	Measure Level (dBuV/m)	Reading Level (dBuV)	Over Limit (dB)	Limit (dBuV/m)	Factor (dB)	Type
1	*	2483.500	55.135	19.617	-18.865	74.000	35.517	PK

Profile: 2150995R	Page No.: 8
Engineer: YULIU	
Site: AC5	Time: 2021/06/22 - 21:56
Limit: FCC_Part15.209_RE(3m)	Margin: 0
Probe: Horn_3117_00167055(1-18GHz)	Polarity: Horizontal
EUT: Wireless Headset	Power: Battery
Note: Mode 1:Transmit at 2477.35MHz	

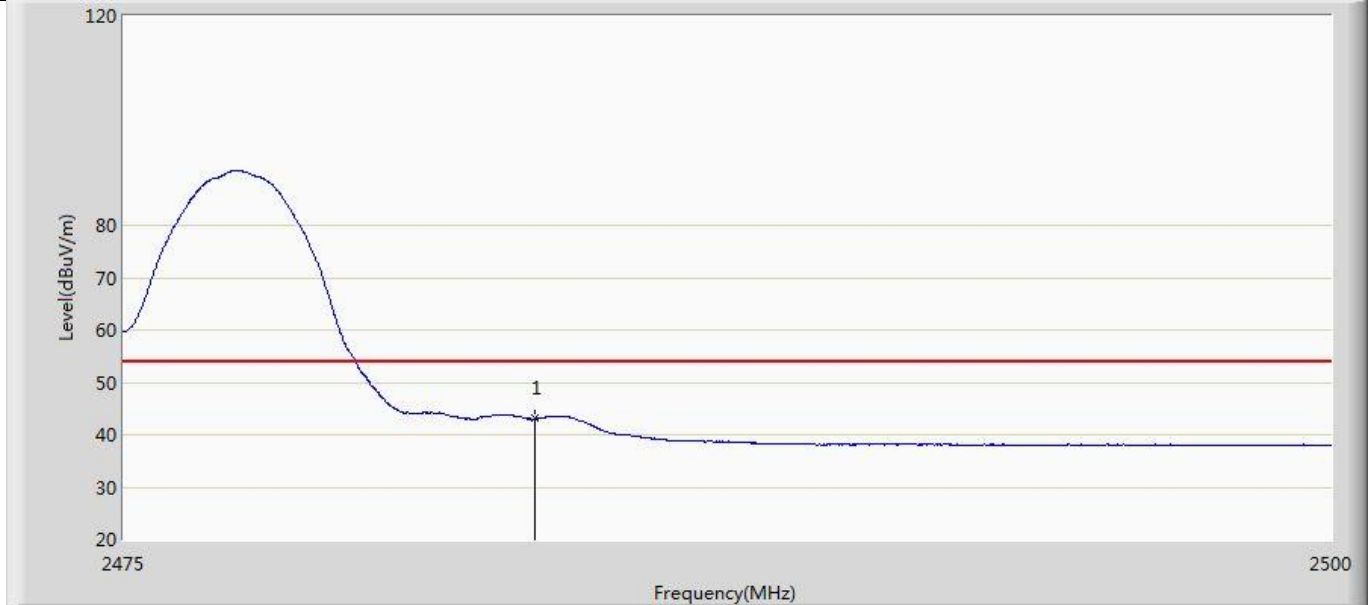

No	Mark	Frequency (MHz)	Measure Level (dBuV/m)	Reading Level (dBuV)	Over Limit (dB)	Limit (dBuV/m)	Factor (dB)	Type
1	*	2483.500	43.074	7.556	-10.926	54.000	35.517	AV

Note:

1. " \* ", means this data is the worst emission level.
2. Measurement Level = Reading Level + Factor(Probe+Cable-Amp).

**4.6 DTS Bandwidth**

**VERDICT: PASS**

**4.6.1 Limit**

**Standard** FCC Part 15 Subpart C Paragraph 15.247 (a)(2)

Systems using digital modulation techniques operate in the 2400-2483.5 MHz. The minimum 6 dB bandwidth shall be at least 500 kHz

**4.6.2 Test Setup**

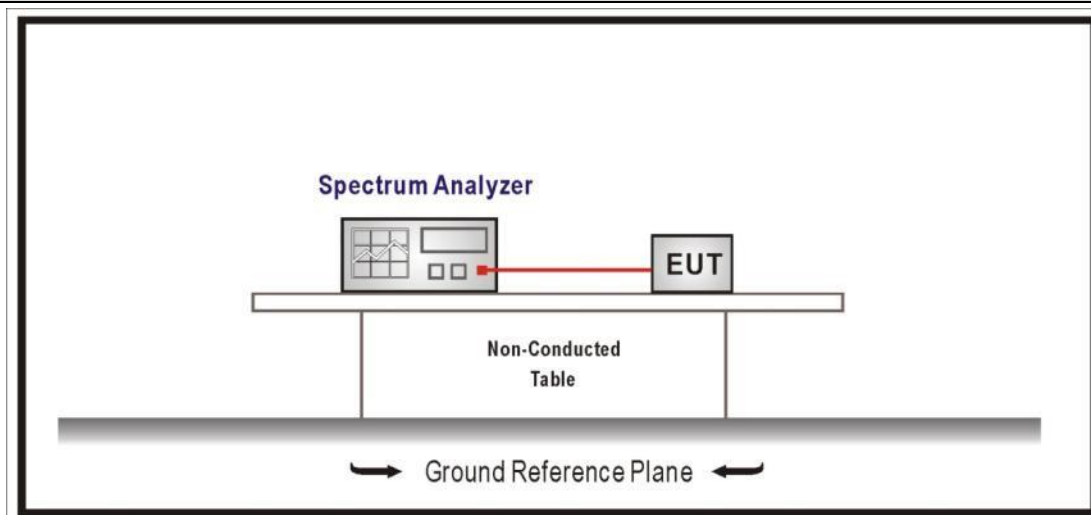

**4.6.3 Test Procedure**

	Reference Rule	Chapter	Description
<input checked="" type="checkbox"/>	ANSI C63.10	11.8	DTS bandwidth
<input type="checkbox"/>	ANSI C63.10	11.8.1	Option 1
<input checked="" type="checkbox"/>	ANSI C63.10	11.8.2	Option 2

**4.6.4 Test Data**

Mode	CH.	Test Freq. (MHz)	99% Occupied Bandwidth (kHz)	6dB Occupied Bandwidth (kHz)	Limit (kHz)	Result
1	02	2405.35	1987.2	1551.0	>500	Pass
	20	2441.35	1992.4	1575.0	>500	Pass
	38	2477.35	2025.4	1649.0	>500	Pass

Note : The worst case of Occupied Bandwidth as below:

Mode 1 CH02 (2405.35MHz)

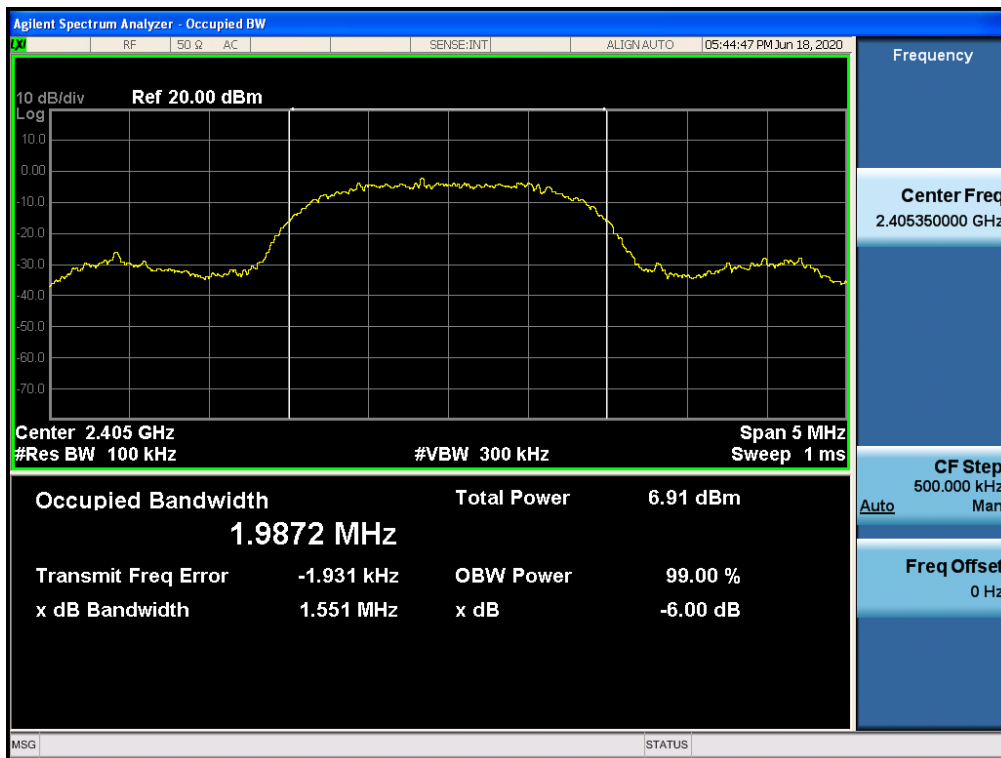

**4.7 Fundamental emission output power**

**VERDICT: PASS**

**4.7.1 Limit**

Standard		FCC Part 15 Subpart C Paragraph 15.247 (b)(3)
<input checked="" type="checkbox"/>	GTX < 6dBi	$P_{out} \leq 30\text{dBm}$
<input type="checkbox"/>	GTX > 6dBi	
<input type="checkbox"/>	Non-Fix point-point	$P_{out} \leq 30 - (GTX - 6)$
<input type="checkbox"/>	Fix point-point	$P_{out} \leq 30 - [(GTX - 6)]/3$
<input type="checkbox"/>	Point-to-multipoint	$P_{out} \leq 30 - (GTX - 6)$
<input type="checkbox"/>	Overlap Beams	$P_{out} \leq 30 - [(GTX - 6)]/3$
<input type="checkbox"/>	Aggregate power transmitted simultaneously on all beams	$P_{out} \leq 30 - [(GTX - 6)]/3$
<input type="checkbox"/>	single directional beam	$P_{out} \leq 30 - [(GTX - 6)]/3 + 8\text{dB}$

Note 1 : GTX directional gain of transmitting antennas.

Note 2 : Pout is maximum peak conducted output power .

**4.7.2 Test Setup**

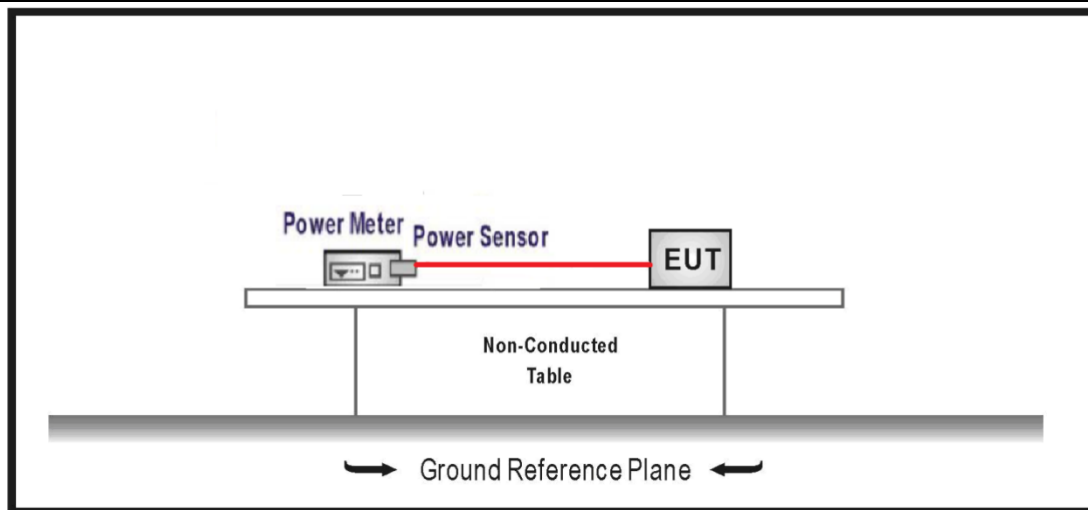



4.7.3 Test Procedure				
	References Rule		Chapter	Description
<input checked="" type="checkbox"/>	ANSI C63.10		11.9	Fundamental emission output power
	<input checked="" type="checkbox"/>	ANSI C63.10	11.9.1	Maximum peak conducted output power
	<input type="checkbox"/>	ANSI C63.10	11.9.1.1	RBW $\geq$ DTS bandwidth
	<input type="checkbox"/>	ANSI C63.10	11.9.1.2	Integrated band power method
	<input type="checkbox"/>	ANSI C63.10	11.9.1.3	PKPM1 Peak power meter method
	<input type="checkbox"/>	ANSI C63.10	11.9.2	Maximum conducted (average) output power
	<input type="checkbox"/>	ANSI C63.10	11.9.2.2	Measurement using a spectrum analyzer (SA)
	<input type="checkbox"/>	ANSI C63.10	11.9.2.2.2	Method AVGSA-1(Duty cycle $\geq 98\%$ )
	<input type="checkbox"/>	ANSI C63.10	11.9.2.2.3	Method AVGSA-1A(Duty cycle $\geq 98\%$ )
	<input type="checkbox"/>	ANSI C63.10	11.9.2.2.4	Method AVGSA-2(Duty cycle $\leq 98\%$ )
	<input type="checkbox"/>	ANSI C63.10	11.9.2.2.5	Method AVGSA-2A(Duty cycle $\leq 98\%$ )
	<input type="checkbox"/>	ANSI C63.10	11.9.2.2.4	Method AVGSA-3
	<input type="checkbox"/>	ANSI C63.10	11.9.2.2.5	Method AVGSA-3A
	<input checked="" type="checkbox"/>	ANSI C63.10	11.9.2.3	Measurement using a power meter (PM)
	<input checked="" type="checkbox"/>	ANSI C63.10	11.9.2.3.1	Method AVGPM
	<input type="checkbox"/>	ANSI C63.10	11.9.2.3.2	Method AVGPM-G

**4.7.4 Test Data**

**FCC**

Mode	Channel	Test Frequency (MHz)	Power Output (dBm)	Limit (dBm)	Result
Mode 1	02	2405.35	4.86	≤30	Pass
	20	2441.35	4.82	≤30	Pass
	38	2477.35	4.65	≤30	Pass

**IC**

Mode	Channel	Test Frequency (MHz)	Power Output (dBm)	EIRP (dBm)	Limit (dBm)	Result
Mode 1	02	2405.35	4.86	6.64	≤30	Pass
	20	2441.35	4.82	6.60	≤30	Pass
	38	2477.35	4.65	6.43	≤30	Pass

Mode	Channel	Test Frequency (MHz)	Average Power (dBm)	Limit (dBm)	Result
Mode 1	02	2405.35	3.86	≤30	Pass
	20	2441.35	3.97	≤30	Pass
	38	2477.35	3.82	≤30	Pass

**4.8 Power Density**

**VERDICT: PASS**

**4.8.1 Limit:**

**Standard**

FCC Part 15 Subpart C Paragraph 15.247 (b)(3)

Power Spectral Density  $\leq 8\text{dBm}/3\text{kHz}$

**4.8.2 Test Setup**

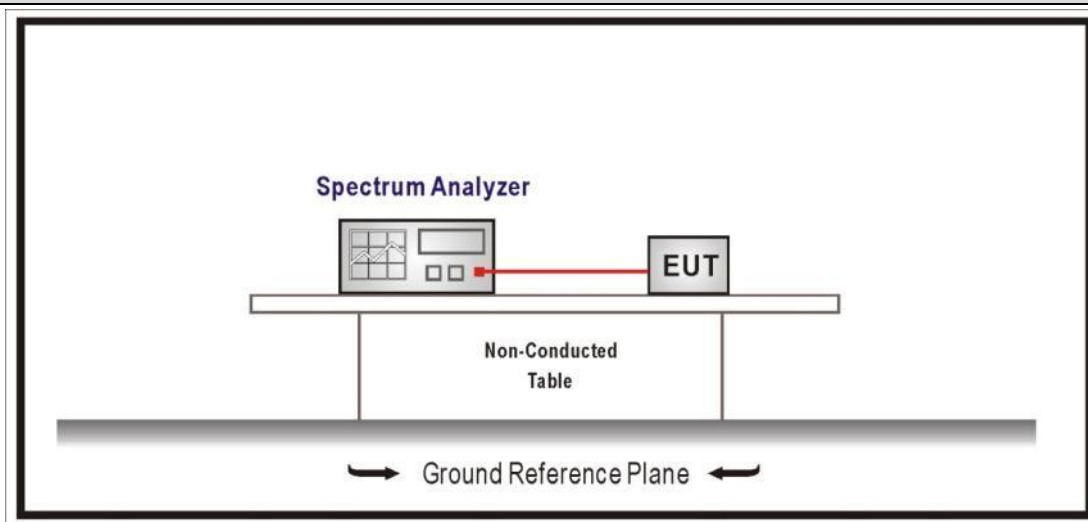

**4.8.3 Test Procedure**

	References Rule	Chapter	Description
<input checked="" type="checkbox"/>	ANSI C63.10	11.10	Maximum power spectral density level in the fundamental emission
	<input checked="" type="checkbox"/> ANSI C63.10	11.10.2	Method PKPSD (peak PSD)
	<input type="checkbox"/> ANSI C63.10	11.10.3	Method AVGPSD-1(Duty cycle $\geq 98\%$ )
	<input type="checkbox"/> ANSI C63.10	11.10.4	Method AVGPSD-1A(Duty cycle $\geq 98\%$ )
	<input type="checkbox"/> ANSI C63.10	11.10.5	Method AVGPSD-2(Duty cycle $< 98\%$ )
	<input type="checkbox"/> ANSI C63.10	11.10.6	Method AVGPSD-2A(Duty cycle $< 98\%$ )
	<input type="checkbox"/> ANSI C63.10	11.10.7	Method AVGPSD-3
	<input type="checkbox"/> ANSI C63.10	11.10.8	Method AVGPSD-3A

**4.8.4 Test Data**

Mode	Channel	Test Frequency (MHz)	Measurement PSD (dBm/3kHz)	Limit (dBm/3kHz)	Result
Mode 1	02	2405.35	-11.537	≤8	Pass
	20	2441.35	-11.284	≤8	Pass
	38	2477.35	-12.742	≤8	Pass

Note : The worst case of PSD as below:

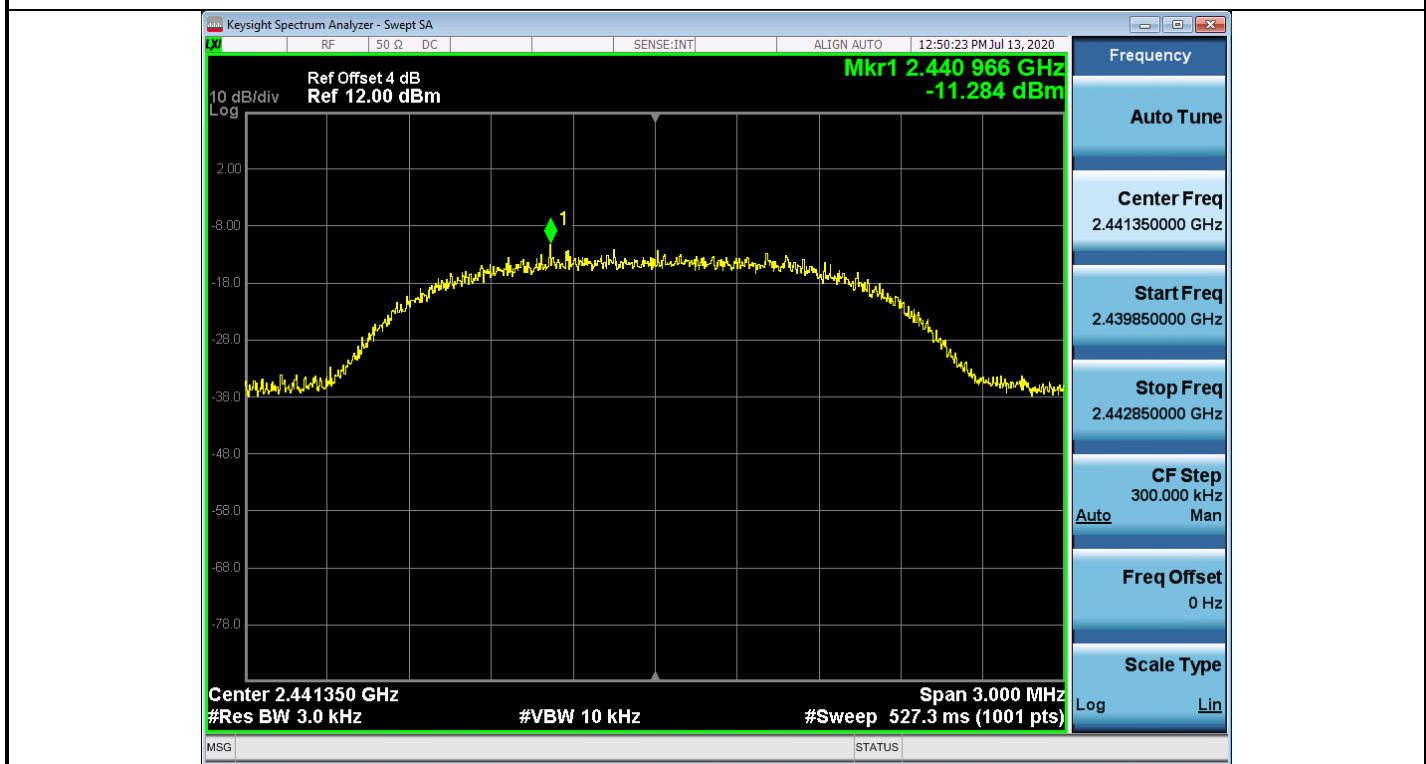

**4.9 Antenna Requirement**

**VERDICT: PASS**

**4.9.1 Limit:**

<b>Standard</b>	FCC Part 15 Subpart C Paragraph 15.203
-----------------	--

An intentional radiator shall be designed to ensure that no antenna other than that furnished by the responsible party shall be used with the device. The use of a permanently attached antenna or of an antenna that uses a unique coupling to the intentional radiator shall be considered sufficient to comply with the provisions of this section. The manufacturer may design the unit so that a broken antenna can be replaced by the user, but the use of a standard antenna jack or electrical connector is prohibited. This requirement does not apply to carrier current devices or to devices operated under the provisions of §15.211, §15.213, §15.217, §15.219, or §15.221. Further, this requirement does not apply to intentional radiators that must be professionally installed, such as perimeter protection systems and some field disturbance sensors, or to other intentional radiators which, in accordance with §15.31(d), must be measured at the installation site. However, the installer shall be responsible for ensuring that the proper antenna is employed so that the limits in this part are not exceeded.

**4.9.2 Antenna Connector Construction:**

- |                                     |  |
|-------------------------------------|--|
| <input checked="" type="checkbox"/> | The use of a permanently attached antenna                        |
| <input type="checkbox"/>            | The antenna use of a unique coupling to the intentional radiator |
| <input type="checkbox"/>            | The use of a nonstandard antenna jack or electrical connector    |

Please refer to the attached document "Internal Photograph" to show the antenna connector.

---

## 5 TEST SETUP PHOTO AND EUT PHOTO

Remark: The test setup photo and EUT Photo please see appendix.

\_\_\_\_\_ The End \_\_\_\_\_