

FCC Radio Test Report

FCC ID: 2AG7C-BULLET5S

This report concerns: Original Grant

Project No. : 2008H002
Equipment : IP CAMERA
Brand Name : N/A
Test Model : Bullet 5S
Series Model : N/A
Applicant : Hangzhou Meari Technology Co., Ltd.
Address : Room 604-605, Building 1, No.768 Jianghong Road,
Changhe street, Binjiang District, Hangzhou, Zhejiang, China
Manufacturer : Hangzhou Meari Technology Co., Ltd.
Address : Room 604-605, Building 1, No.768 Jianghong Road,
Changhe street, Binjiang District, Hangzhou, Zhejiang, China
Factory : Hangzhou Meari Technology Co., Ltd.
Address : No. 91 Chutian Road, Xixing Street, Binjiang District,
Hangzhou, Zhejiang, China
Date of Receipt : Aug. 04, 2020
Date of Test : Aug. 04, 2020~Aug. 18, 2020
Issued Date : Aug. 28, 2020
Report Version : R00
Test Sample : Engineering Sample No.: SH2020080442, adapter: SH2020080442-3
Standard(s) : FCC Part15, Subpart C (15.247)
ANSI C63.10-2013
KDB 558074 D01 15.247 Meas Guidance v05r02

The above equipment has been tested and found compliance with the requirement of the relative standards by BTL Inc.

Allen Wei

Prepared by : Allen Wei

Ryan Wang

Approved by : Ryan Wang



Certificate # 5123.03

Add: No. 29, Jintang Road, Tangzhen Industry Park, Pudong New Area, Shanghai 201210, China

TEL: +86-021-61765666

Web: www.newbtl.com

Declaration

BTL represents to the client that testing is done in accordance with standard procedures as applicable and that test instruments used has been calibrated with standards traceable to international standard(s) and/or national standard(s).

BTL's reports apply only to the specific samples tested under conditions. It is manufacture's responsibility to ensure that additional production units of this model are manufactured with the identical electrical and mechanical components. **BTL** shall have no liability for any declarations, inferences or generalizations drawn by the client or others from **BTL** issued reports.

The report must not be used by the client to claim product certification, approval, or endorsement by NVLAP, NIST, A2LA, or any agency of the U.S. Government.

This report is the confidential property of the client. As a mutual protection to the clients, the public and ourselves, the test report shall not be reproduced, except in full, without our written approval.

BTL's laboratory quality assurance procedures are in compliance with the **ISO/IEC 17025** requirements, and accredited by the conformity assessment authorities listed in this test report.

BTL is not responsible for the sampling stage, so the results only apply to the sample as received.

The information, data and test plan are provided by manufacturer which may affect the validity of results, so it is manufacturer's responsibility to ensure that the apparatus meets the essential requirements of applied standards and in all the possible configurations as representative of its intended use.

Limitation

For the use of the authority's logo is limited unless the Test Standard(s)/Scope(s)/Item(s) mentioned in this test report is (are) included in the conformity assessment authorities acceptance respective.

Please note that the measurement uncertainty is provided for informational purpose only and are not use in determining the Pass/Fail results.

Table of Contents	Page
REPORT ISSUED HISTORY	6
1 . SUMMARY OF TEST RESULTS	7
1.1 TEST FACILITY	8
1.2 MEASUREMENT UNCERTAINTY	8
1.3 TEST ENVIRONMENT CONDITIONS	8
2 . GENERAL INFORMATION	9
2.1 GENERAL DESCRIPTION OF EUT	9
2.2 DESCRIPTION OF TEST MODES	10
2.3 PARAMETERS OF TEST SOFTWARE	12
2.4 DUTY CYCLE	13
2.5 BLOCK DIAGRAM SHOWING THE CONFIGURATION OF SYSTEM TESTED	14
2.6 SUPPORT UNITS	14
3 . AC POWER LINE CONDUCTED EMISSIONS TEST	15
3.1 LIMIT	15
3.2 TEST PROCEDURE	15
3.3 DEVIATION FROM TEST STANDARD	15
3.4 TEST SETUP	16
3.5 EUT OPERATION CONDITIONS	16
3.6 TEST RESULTS	16
4 . RADIATED EMISSIONS TEST	17
4.1 LIMIT	17
4.2 TEST PROCEDURE	18
4.3 DEVIATION FROM TEST STANDARD	18
4.4 TEST SETUP	19
4.5 EUT OPERATION CONDITIONS	20
4.6 TEST RESULTS - 9 KHZ TO 30 MHZ	20
4.7 TEST RESULTS - 30 MHZ TO 1000 MHZ	20
4.8 TEST RESULTS - ABOVE 1000 MHZ	20
5 . BANDWIDTH TEST	21
5.1 LIMIT	21
5.2 TEST PROCEDURE	21
5.3 DEVIATION FROM STANDARD	21
5.4 TEST SETUP	21

Table of Contents	Page
5.5 EUT OPERATION CONDITIONS	21
5.6 TEST RESULTS	21
6 . MAXIMUM OUTPUT POWER TEST	22
6.1 LIMIT	22
6.2 TEST PROCEDURE	22
6.3 DEVIATION FROM STANDARD	22
6.4 TEST SETUP	22
6.5 EUT OPERATION CONDITIONS	22
6.6 TEST RESULTS	22
7 . CONDUCTED SPURIOUS EMISSIONS	23
7.1 LIMIT	23
7.2 TEST PROCEDURE	23
7.3 DEVIATION FROM STANDARD	23
7.4 TEST SETUP	23
7.5 EUT OPERATION CONDITIONS	23
7.6 TEST RESULTS	23
8 . POWER SPECTRAL DENSITY TEST	24
8.1 LIMIT	24
8.2 TEST PROCEDURE	24
8.3 DEVIATION FROM STANDARD	24
8.4 TEST SETUP	24
8.5 EUT OPERATION CONDITIONS	24
8.6 TEST RESULTS	24
9 . MEASUREMENT INSTRUMENTS LIST	25
10 . EUT TEST PHOTO	27
APPENDIX A - AC POWER LINE CONDUCTED EMISSIONS	30
APPENDIX B - RADIATED EMISSION - 9 KHZ TO 30 MHZ	33
APPENDIX C - RADIATED EMISSION - 30 MHZ TO 1000 MHZ	34
APPENDIX D - RADIATED EMISSION- ABOVE 1000 MHZ	37
APPENDIX E - BANDWIDTH	86
APPENDIX F - MAXIMUM OUTPUT POWER	91
APPENDIX G - CONDUCTED SPURIOUS EMISSIONS	93

Table of Contents**Page****APPENDIX H - POWER SPECTRAL DENSITY****98**

REPORT ISSUED HISTORY

Report Version	Description	Issued Date
R00	Original Issue.	Aug. 28, 2020

1. SUMMARY OF TEST RESULTS

Test procedures according to the technical standard(s):

FCC Part15, Subpart C (15.247)				
Standard(s) Section	Test Item	Test Result	Judgment	Remark
15.207	AC Power Line Conducted Emissions	APPENDIX A	PASS	-----
15.247(d) 15.205(a) 15.209(a)	Radiated Emissions	APPENDIX B APPENDIX C APPENDIX D	PASS	-----
15.247(a)(2)	Bandwidth	APPENDIX E	PASS	-----
15.247(b)(3)	Maximum Output Power	APPENDIX F	PASS	-----
15.247(d)	Conducted Spurious Emissions	APPENDIX G	PASS	-----
15.247(e)	Power Spectral Density	APPENDIX H	PASS	-----
15.203	Antenna Requirement	-----	PASS	Note(2)

Note:

- (1) "N/A" denotes test is not applicable in this test report.
- (2) The device what use a permanently attached antenna were considered sufficient to comply with the provisions of 15.203.

1.1 TEST FACILITY

The test facilities used to collect the test data in this report is at the location of No. 29, Jintang Road, Tangzhen Industry Park, Pudong New Area, Shanghai 201210,China
 BTL's Test Firm Registration Number for FCC: 476765
 BTL's Designation Number for FCC: CN1241

1.2 MEASUREMENT UNCERTAINTY

ISO/IEC 17025 requires that an estimate of the measurement uncertainties associated with the emissions test results be included in the report. The measurement uncertainties given below are based on a 95% confidence level (based on a coverage factor (k=2))
 The BTL measurement uncertainty as below table:

A. Radiated emissions test:

Test Site	Method	Measurement Frequency Range	Ant. H / V	U, (dB)
SH-CB01	CISPR	9 KHz~30 MHz	V	3.79
		9 KHz~30 MHz	H	3.57
		30 MHz~200 MHz	V	4.04
		30 MHz~200 MHz	H	3.76
		200 MHz~1,000 MHz	V	4.24
		200 MHz~1,000 MHz	H	3.84
		1 GHz~18 GHz	V	4.46
		1 GHz~18 GHz	H	4.40
		18 GHz~40 GHz	V	3.95
		18 GHz~40 GHz	H	3.95

Note: Unless specifically mentioned, the uncertainty of measurement has not been taken into account to declare the compliance or non-compliance to the specification.

1.3 TEST ENVIRONMENT CONDITIONS

Test Item	Temperature	Humidity	Test Voltage	Tested By
AC Power Line Conducted Emissions	24°C	58%	AC 120V/60Hz	Forest
Radiated Emissions-9K-30MHz	24°C	58%	AC 120V/60Hz	Forest
Radiated Emissions-30 MHz to 1GHz	24°C	58%	AC 120V/60Hz	Forest
Radiated Emissions-Above 1000 MHz	24°C	58%	AC 120V/60Hz	Forest
Bandwidth	23°C	50%	AC 120V/60Hz	Forest
Maximum output power	23°C	50%	AC 120V/60Hz	Forest
Conducted Spurious Emissions	23°C	50%	AC 120V/60Hz	Forest
Power Spectral Density	23°C	50%	AC 120V/60Hz	Forest

2. GENERAL INFORMATION

2.1 GENERAL DESCRIPTION OF EUT

Equipment	IP CAMERA
Brand Name	N/A
Test Model	Bullet 5S
Series Model	N/A
Model Difference(s)	N/A
Software Version	Smart life
Hardware Version	PCB-DJ-38X38-H1MB_GC2063-REV1.0
Power Source	DC voltage supplied from AC/DC adapter. 1#Brand/Mode:Dachuan/DCT12W120100US-A0 2#Brand/Mode:Keyu/KA1201A-1201000US
Power Rating	1# I/P: 100V-240V ~ 50Hz/60Hz 0.3A max, O/P:12V === 1.0A. 2# I/P: 100V-240V ~ 50Hz/60Hz 0.4A Max, O/P:12V === 1000mA.
Operation Frequency	2412 MHz ~ 2462 MHz
Modulation Type	IEEE 802.11b: DSSS IEEE 802.11g: OFDM IEEE 802.11n: OFDM
Bit Rate of Transmitter	IEEE 802.11b: 11/5.5/2/1 Mbps IEEE 802.11g: 54/48/36/24/18/12/9/6 Mbps IEEE 802.11n: up to 150 Mbps
Maximum Output Power	IEEE 802.11b: 12.71dBm (0.0187W) IEEE 802.11g: 14.58 dBm (0.0287W) IEEE 802.11n (HT20): 14.82 dBm (0.0303 W) IEEE 802.11n (HT40): 14.82dBm (0.0303W)

Note:

- For a more detailed features description, please refer to the manufacturer's specifications or the user's manual.
- Channel List:

CH01 - CH11 for IEEE 802.11b, IEEE 802.11g, IEEE 802.11n (HT20) CH03 - CH09 for IEEE 802.11n (HT40)							
Channel	Frequency (MHz)	Channel	Frequency (MHz)	Channel	Frequency (MHz)	Channel	Frequency (MHz)
01	2412	04	2427	07	2442	10	2457
02	2417	05	2432	08	2447	11	2462
03	2422	06	2437	09	2452		

3. Antenna Specification:

Ant.	Brand	Model Name	Antenna Type	Connector	Gain (dBi)	Note
1	UB	UB02C115B3D1322A	dipole	RF Cable+Terminal	3	N/A

2.2 DESCRIPTION OF TEST MODES

The test system was pre-tested based on the consideration of all possible combinations of EUT operation mode.

Pretest Mode	Description
Mode 1	TX B Mode Channel 01/06/11
Mode 2	TX G Mode Channel 01/06/11
Mode 3	TX N-20 MHz Mode Channel 01/06/11
Mode 4	TX N-40 MHz Mode Channel 03/06/09
Mode 5	TX N40 Mode Channel 03

Following mode(s) as (were) found to be the worst case(s) and selected for the final test.

AC power line conducted emissions test	
Final Test Mode:	Description
Mode 5	TX N40 Mode Channel 03

Radiated emissions test - Below 1GHz	
Final Test Mode:	Description
Mode 5	TX N40 Mode Channel 03

Radiated emissions test- Above 1GHz	
Final Test Mode:	Description
Mode 1	TX B Mode Channel 01/06/11
Mode 2	TX G Mode Channel 01/06/11
Mode 3	TX N-20 MHz Mode Channel 01/06/11
Mode 4	TX N-40 MHz Mode Channel 03/06/09

Conducted test	
Final Test Mode:	Description
Mode 1	TX B Mode Channel 01/06/11
Mode 2	TX G Mode Channel 01/06/11
Mode 3	TX N-20 MHz Mode Channel 01/06/11
Mode 4	TX N-40 MHz Mode Channel 03/06/09

NOTE:

(1) The measurements are performed at the high, middle, low available channels.

(2) 802.11b mode: CCK (1 Mbps)

802.11g mode: OFDM (6 Mbps)

802.11n HT20 mode : BPSK (6.5 Mbps)

802.11n HT40 mode : BPSK (13.5 Mbps)

For radiated emission tests, the highest output powers were set for final test.

(3) For radiated emission below 1 GHz test, the IEEE 802.11n40 Channel 03 is found to be the worst case and recorded.

2.3 PARAMETERS OF TEST SOFTWARE

Test Software	MPTool		
Frequency (MHz)	2412	2437	2462
IEEE 802.11b	30	29	27
IEEE 802.11g	52	49	49
IEEE 802.11n (HT20)	49	49	49
Frequency (MHz)	2422	2437	2452
IEEE 802.11n (HT40)	51	51	50

2.4 DUTY CYCLE

If duty cycle is $\geq 98\%$, duty factor is not required.
 If duty cycle is $< 98\%$, duty factor shall be considered.
 The output power = measured power + duty factor.

IEEE 802.11b

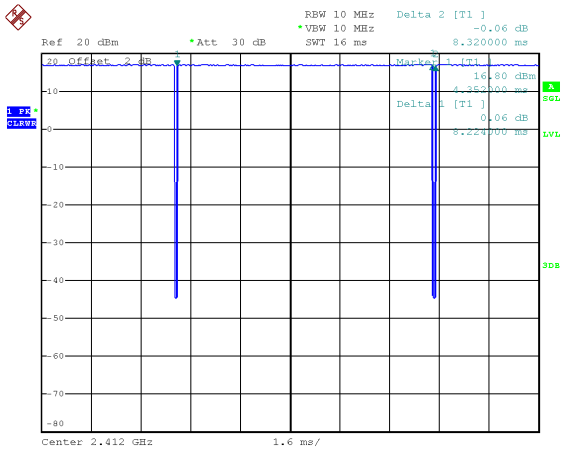

IEEE 802.11g

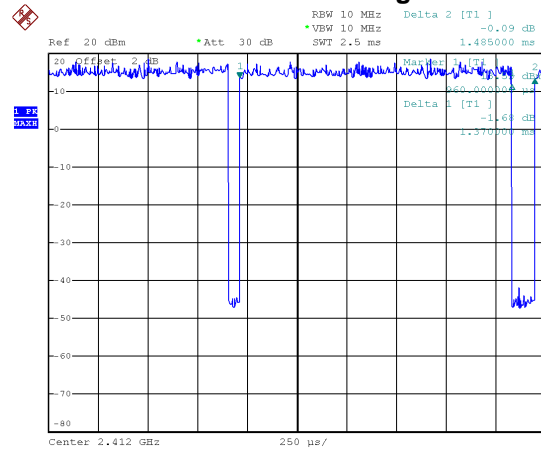

Date: 10.AUG.2020 17:47:07

Duty cycle = $8.224 \text{ ms} / 8.320 \text{ ms} = 98.85\%$
 Duty Factor = $10 \log(1/\text{Duty cycle}) = 0.00$

Date: 10.AUG.2020 17:49:51

Duty cycle = $1.370 \text{ ms} / 1.485 \text{ ms} = 92.26\%$
 Duty Factor = $10 \log(1/\text{Duty cycle}) = 0.35$

IEEE 802.11n (HT20)

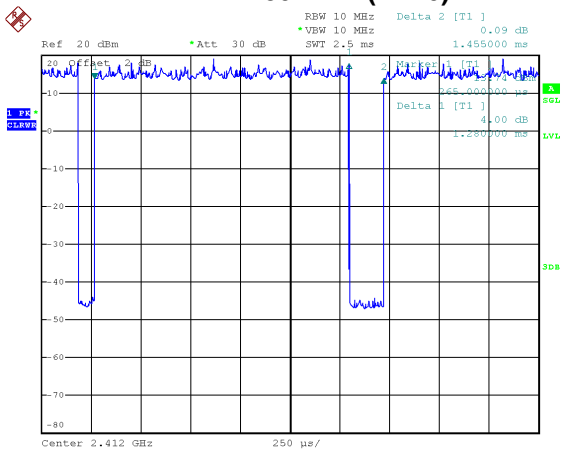

IEEE 802.11n (HT40)

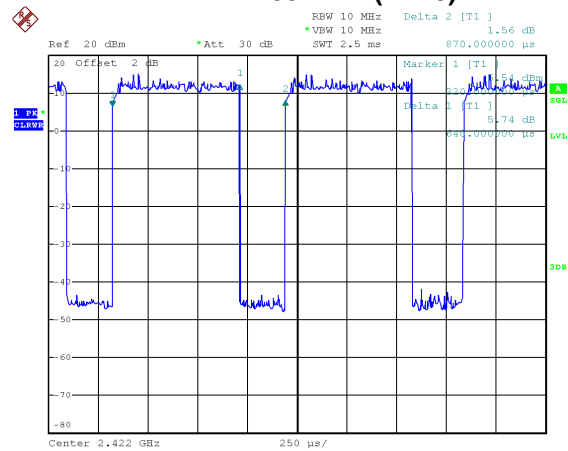

Date: 10.AUG.2020 17:48:50

Duty cycle = $1.280 \text{ ms} / 1.455 \text{ ms} = 87.97\%$
 Duty Factor = $10 \log(1/\text{Duty cycle}) = 0.56$

Date: 10.AUG.2020 18:05:18

Duty cycle = $0.640 \text{ ms} / 0.870 \text{ ms} = 73.56\%$
 Duty Factor = $10 \log(1/\text{Duty cycle}) = 1.33$

NOTE:

For IEEE 802.11g and IEEE 802.11n (HT20):

For radiated emissions frequency above 1 GHz, the resolution bandwidth of test receiver/spectrum analyzer is 1 MHz and the video bandwidth is 1 kHz (Duty cycle $< 98\%$).

For IEEE 802.11n (HT40):

For radiated emissions frequency above 1 GHz, the resolution bandwidth of test receiver/spectrum analyzer is 1 MHz and the video bandwidth is 2 kHz (Duty cycle $< 98\%$).

2.5 BLOCK DIAGRAM SHOWING THE CONFIGURATION OF SYSTEM TESTED

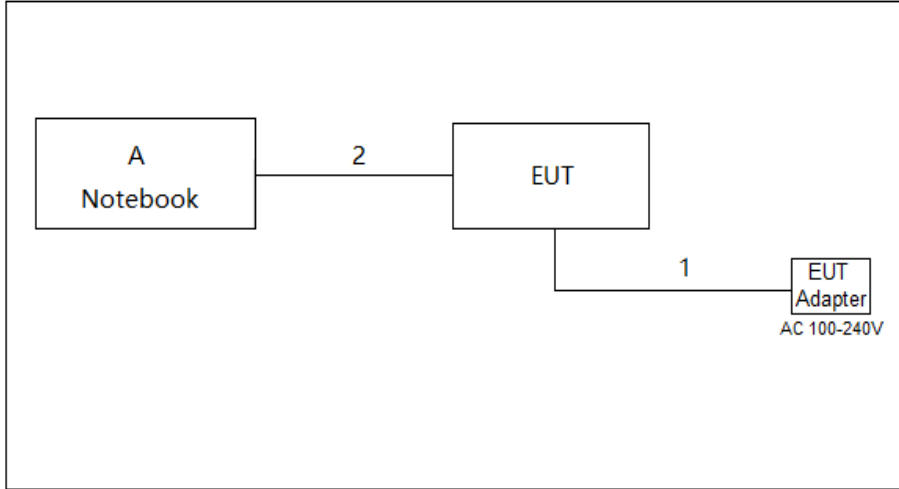

2.6 SUPPORT UNITS

Item	Equipment	Brand	Model No.	Series No.
A	Notebook	Dell	Inspiron 14-7472	N/A

Item	Cable Type	Shielded Type	Ferrite Core	Length
1	DC Cable	NO	NO	4m
2	USB	NO	NO	0.2m

3. AC POWER LINE CONDUCTED EMISSIONS TEST

3.1 LIMIT

Frequency of Emission (MHz)	Limit (dB μ V)	
	Quasi-peak	Average
0.15 - 0.50	66 to 56*	56 to 46*
0.50 - 5.0	56	46
5.0 - 30.0	60	50

NOTE:

- (1) The tighter limit applies at the band edges.
- (2) The limit of " * " marked band means the limitation decreases linearly with the logarithm of the frequency in the range.

The following table is the setting of the receiver

Receiver Parameters	Setting
Attenuation	10 dB
Start Frequency	0.15 MHz
Stop Frequency	30 MHz
IF Bandwidth	9 kHz

3.2 TEST PROCEDURE

- a. The EUT was placed 0.8 meters from the horizontal ground plane with EUT being connected to the power mains through a line impedance stabilization network (LISN). All other support equipment powered from additional LISN(s). The LISN provide 50 Ohm/ 50uH of coupling impedance for the measuring instrument.
- b. Interconnecting cables that hang closer than 40 cm to the ground plane shall be folded back and forth in the center forming a bundle 30 to 40 cm long.
- c. I/O cables that are not connected to a peripheral shall be bundled in the center. The end of the cable may be terminated, if required, using the correct terminating impedance. The overall length shall not exceed 1 m.
- d. LISN at least 80 cm from nearest part of EUT chassis.
- e. For the actual test configuration, please refer to the related Item -EUT Test Photos.

3.3 DEVIATION FROM TEST STANDARD

No deviation

3.4 TEST SETUP

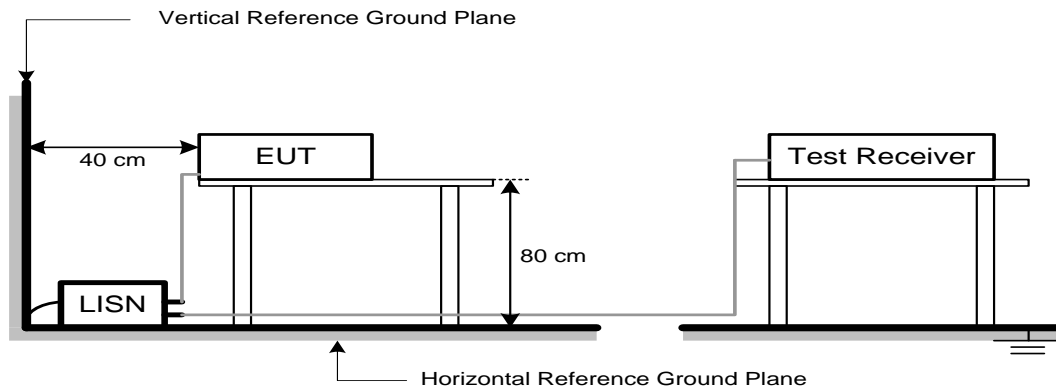

3.5 EUT OPERATION CONDITIONS

EUT was programmed to be in continuously transmitting mode.

3.6 TEST RESULTS

Please refer to the Appendix A.

4. RADIATED EMISSIONS TEST

4.1 LIMIT

In case the emission fall within the restricted band specified on 15.205(a), then the 15.209(a) limit in the table below has to be followed.

LIMITS OF RADIATED EMISSION MEASUREMENT (9 kHz-1000 MHz)

Frequency (MHz)	Field Strength (microvolts/meter)	Measurement Distance (meters)
0.009-0.490	2400/F(kHz)	300
0.490-1.705	24000/F(kHz)	30
1.705-30.0	30	30
30-88	100	3
88-216	150	3
216-960	200	3
Above 960	500	3

LIMITS OF RADIATED EMISSION MEASUREMENT (Above 1000 MHz)

Frequency (MHz)	(dBuV/m at 3 m)	
	Peak	Average
Above 1000	74	54

NOTE:

- (1) The limit for radiated test was performed according to FCC PART 15C.
- (2) The tighter limit applies at the band edges.
- (3) Emission level (dBuV/m)=20log Emission level (uV/m).
- (4) The test result calculated as following:
 Measurement Value = Reading Level + Correct Factor
 Correct Factor = Antenna Factor + Cable Loss - Amplifier Gain(if use)
 Margin Level = Measurement Value - Limit Value

Spectrum Parameter	Setting
Attenuation	Auto
Start Frequency	1000 MHz
Stop Frequency	10th carrier harmonic
RBW / VBW (Emission in restricted band)	1 MHz / 3 MHz for Peak, 1 MHz / 1/T for Average

Receiver Parameter	Setting
Attenuation	Auto
Start ~ Stop Frequency	9 kHz~90 kHz for PK/AVG detector
Start ~ Stop Frequency	90 kHz~110 kHz for QP detector
Start ~ Stop Frequency	110 kHz~490 kHz for PK/AVG detector
Start ~ Stop Frequency	490 kHz~30 MHz for QP detector
Start ~ Stop Frequency	30 MHz~1000 MHz for QP detector

4.2 TEST PROCEDURE

- a. The measuring distance of 3 m shall be used for measurements. The EUT was placed on the top of a rotating table 0.8 meter above the ground at a 3 meter semi-anechoic chamber. The table was rotated 360 degrees to determine the position of the highest radiation.(below 1 GHz)
- b. The measuring distance of 3 m shall be used for measurements. The EUT was placed on the top of a rotating table 1.5 meter above the ground at a 3 meter semi-anechoic chamber. The table was rotated 360 degrees to determine the position of the highest radiation.(above 1 GHz)
- c. The height of the equipment or of the substitution antenna shall be 0.8m or 1.5m; the height of the test antenna shall vary between 1 m to 4 m. Both horizontal and vertical polarizations of the antenna are set to make the measurement.
- d. For each suspected emission, the EUT was arranged to its worst case and then the antenna was tuned to heights find the maximum reading (used Bore sight function).
- e. The receiver system was set to peak and average detect function and specified bandwidth with maximum hold mode when the test frequency is above 1 GHz.
- f. The initial step in collecting radiated emission data is a receiver peak detector mode pre-scanning the measurement frequency range. Significant peaks are then marked and then Quasi Peak detector mode re-measured.
- g. All readings are Peak unless otherwise stated QP in column of Note. Peak denotes that the Peak reading compliance with the QP Limits and then QP Mode measurement didn't perform.
(below 1 GHz)
- h. All readings are Peak Mode value unless otherwise stated AVG in column of Note. If the Peak Mode Measured value compliance with the Peak Limits and lower than AVG Limits, the EUT shall be deemed to meet both Peak & AVG Limits and then only Peak Mode was measured, but AVG Mode didn't perform. (above 1 GHz)
- i. For the actual test configuration, please refer to the related Item -EUT Test Photos.

4.3 DEVIATION FROM TEST STANDARD

No deviation

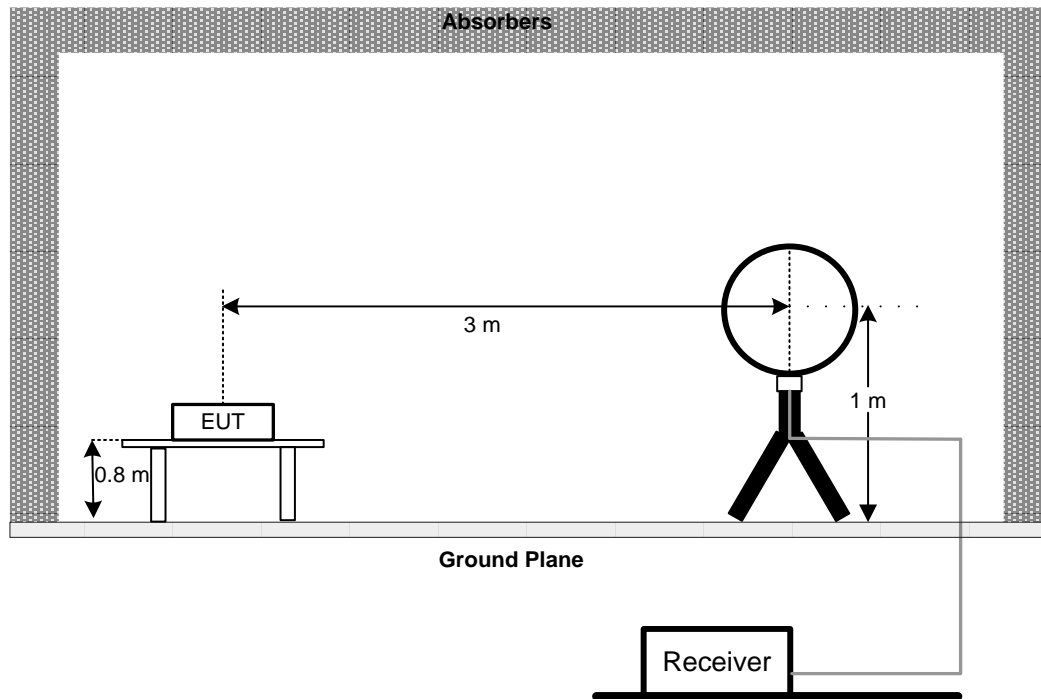
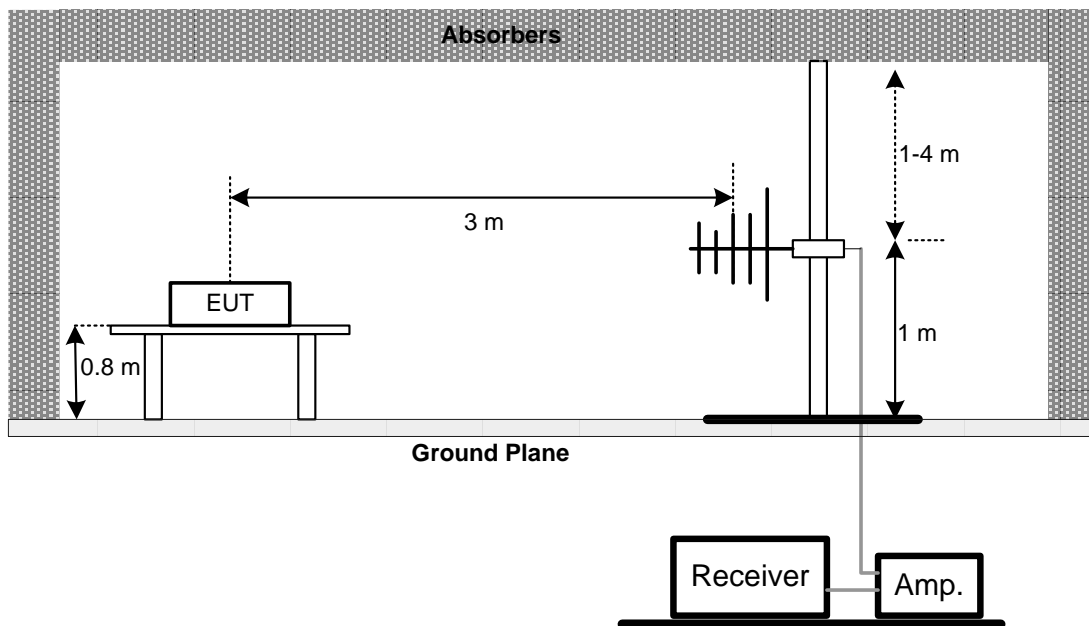
4.4 TEST SETUP**9 kHz-30 MHz****30 MHz to 1 GHz**

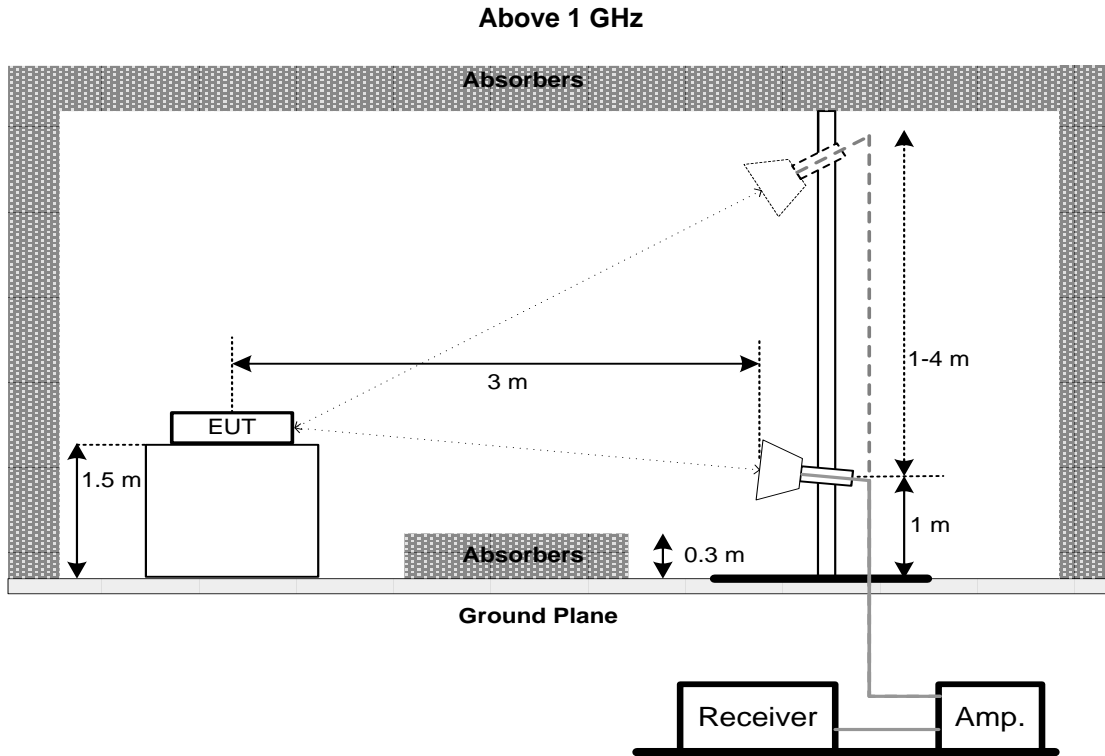

4.5 EUT OPERATION CONDITIONS

The EUT was programmed to be in continuously transmitting mode.

4.6 TEST RESULTS - 9 KHZ TO 30 MHZ

Please refer to the APPENDIX B

Remark:

- (1) Distance extrapolation factor = $40 \log (\text{specific distance} / \text{test distance})$ (dB).
- (2) Limit line = specific limits (dBuV) + distance extrapolation factor.

4.7 TEST RESULTS - 30 MHZ TO 1000 MHZ

Please refer to the APPENDIX C.

4.8 TEST RESULTS - ABOVE 1000 MHZ

Please refer to the APPENDIX D.

Remark:

- (1) No limit: This is fundamental signal, the judgment is not applicable.
For fundamental signal judgment was referred to Peak output test.

5. BANDWIDTH TEST

5.1 LIMIT

FCC Part15, Subpart C (15.247)		
Section	Test Item	Limit
15.247(a)(2)	6 dB Bandwidth	Minimum 500 kHz
	99% Emission Bandwidth	-

5.2 TEST PROCEDURE

- a. The EUT was directly connected to the spectrum analyzer and antenna output port as show in the block diagram below.
- b. Spectrum Setting:
 - For 6 dB Bandwidth : RBW= 100 kHz, VBW=300 kHz, Sweep time = auto.
 - For 99% Emission Bandwidth B/G/N-20 Mode: RBW= 300 KHz, VBW=1 MHz, Sweep time = 2.5 ms.
 - For 99% Emission Bandwidth N-40 Mode: RBW= 1 MHz, VBW=3 MHz, Sweep time = 2.5 ms.
- c. The bandwidth was performed in accordance with method 11.8.1 of ANSI C63.10-2013.

5.3 DEVIATION FROM STANDARD

No deviation.

5.4 TEST SETUP

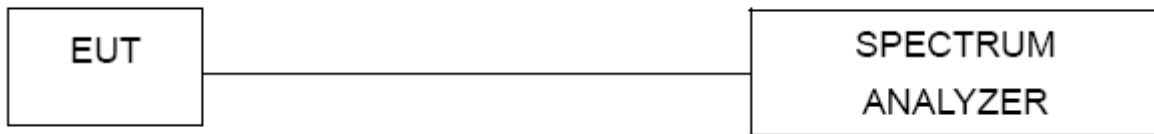

5.5 EUT OPERATION CONDITIONS

The EUT was programmed to be in continuously transmitting mode.

5.6 TEST RESULTS

Please refer to the APPENDIX E.

6. MAXIMUM OUTPUT POWER TEST

6.1 LIMIT

FCC Part15, Subpart C (15.247)		
Section	Test Item	Limit
15.247(b)(3)	Maximum Output Power	1 Watt or 30dBm

6.2 TEST PROCEDURE

- a. The EUT was directly connected to the power meter and antenna output port as show in the block diagram below.
- b. The maximum conducted output power was performed in accordance with method 11.9.1.3 (for peak power) or 11.9.2.3.1 (for AVG power) of ANSI C63.10-2013.

6.3 DEVIATION FROM STANDARD

No deviation.

6.4 TEST SETUP



6.5 EUT OPERATION CONDITIONS

The EUT was programmed to be in continuously transmitting mode.

6.6 TEST RESULTS

Please refer to the APPENDIX F.

7. CONDUCTED SPURIOUS EMISSIONS

7.1 LIMIT

In any 100 kHz bandwidth outside the frequency band in which the spread spectrum or digitally modulated intentional radiator is operating, the radio frequency power that is produced by the intentional radiator shall be at least 20 dB below that in the 100 kHz bandwidth within the band that contains the highest level of the desired power, based on either an RF conducted or a radiated measurement, provided the transmitter demonstrates compliance with the peak Output Power limits. If the transmitter complies with the Output Power limits based on the use of RMS averaging over a time interval, as permitted under paragraph (b)(3) of this section, the attenuation required under this paragraph shall be 30 dB instead of 20 dB. Attenuation below the general limits specified in Section 15.209(a) is not required.

7.2 TEST PROCEDURE

- a. The EUT was directly connected to the spectrum analyzer and antenna output port as show in the block diagram below.
- b. Spectrum Setting: RBW= 100 kHz, VBW=300 kHz, Sweep time = Auto.

7.3 DEVIATION FROM STANDARD

No deviation.

7.4 TEST SETUP



7.5 EUT OPERATION CONDITIONS

The EUT was programmed to be in continuously transmitting mode.

7.6 TEST RESULTS

Please refer to the Appendix G.

8. POWER SPECTRAL DENSITY TEST

8.1 LIMIT

FCC Part15, Subpart C (15.247)		
Section	Test Item	Limit
15.247(e)	Power Spectral Density	8 dBm (in any 3 kHz)

8.2 TEST PROCEDURE

- The EUT was directly connected to the spectrum analyzer and antenna output port as show in the block diagram below.
- Spectrum Setting: RBW=3 kHz, VBW=10 kHz, Sweep time = Auto.
- The Power Spectral Density was performed in accordance with method 11.10.2 of ANSI C63.10-2013.

8.3 DEVIATION FROM STANDARD

No deviation.

8.4 TEST SETUP



8.5 EUT OPERATION CONDITIONS

The EUT was programmed to be in continuously transmitting mode.

8.6 TEST RESULTS

Please refer to the APPENDIX H.

9. MEASUREMENT INSTRUMENTS LIST

AC Power Line Conducted Emissions					
Item	Kind of Equipment	Manufacturer	Type No.	Serial No.	Calibrated until
1	Line Impedance Stabilisation Network	Schwarzbeck	NNLK 8121	8121-822	Mar. 21, 2021
2	TWO-LINE V-NETWORK	R&S	ENV216	101340	Sep. 01, 2020
3	Test Cable	emci	EMCRG400-BM-N M-10000	170628	Jul. 15, 2021
4	EMI Test Receiver	R&S	ESCI	100082	Mar. 21, 2021
5	50Ω Terminator	SHX	TF2-1G-A	17051602	Mar. 21, 2021
6	50Ω coaxial switch	Anritsu	MP59B	6201750902	Mar. 21, 2021
7	Measurement Software	Farad	EZ-EMC Ver.NB-03A1-01	N/A	N/A

Radiated Emissions - 9 kHz to 30 MHz					
Item	Kind of Equipment	Manufacturer	Type No.	Serial No.	Calibrated until
1	Loop Antenna	EMCI	EMCI LPA600	275	Apr. 02, 2021
2	EMI Test Receiver	R&S	ESCI	100082	Mar. 21, 2021
3	Measurement Software	Farad	EZ-EMC Ver.NB-03A1-01	N/A	N/A

Radiated Emissions - 30 MHz to 1 GHz					
Item	Kind of Equipment	Manufacturer	Type No.	Serial No.	Calibrated until
1	TRILOG Broadband Antenna	Schwarzbeck	VULB 9168	719	Apr. 02, 2021
2	Pre-Amplifier	emci	EMC9135	980400	Mar. 21, 2021
3	MXE EMI Receiver	Keysight	N9038A	MY57150106	May. 06, 2021
4	Test Cable	emci	EMC104-SM-SM-7 000	170330	Apr. 13, 2021
5	Test Cable	emci	EMC104-SM-SM-1 000	170331	Apr. 13, 2021
6	Test Cable	emci	EMC104-SM-NM-3 500	170621	Apr. 13, 2021
7	Measurement Software	Farad	EZ-EMC Ver.NB-03A1-01	N/A	N/A

Radiated Emissions - Above 1 GHz					
Item	Kind of Equipment	Manufacturer	Type No.	Serial No.	Calibrated until
1	Double-Ridged Waveguide Horn Antenna	ETS-Lindgren	9120D	00206960	Apr. 02, 2021
2	Pre-Amplifier	emci	EMC012645SE	980421	May. 11, 2021
3	EXA Spectrum Analyzer	Keysight	N9010A	MY56480545	Mar. 21, 2021
4	Test Cable	emci	EMC104-SM-SM-7000	170330	Apr. 13, 2021
5	Test Cable	emci	EMC104-SM-SM-1000	170331	Apr. 13, 2021
6	Test Cable	emci	EMC104-SM-NM-3500	170621	Apr. 13, 2021
7	Measurement Software	Farad	EZ-EMC Ver.NB-03A1-01	N/A	N/A
8	MXE EMI Receiver	Keysight	N9038A	MY57150106	May. 06, 2021
9	Double-Ridged Waveguide Horn Antenna	ETS-Lindgren	3116C	00203919	Mar. 21, 2021
10	Pre-Amplifier	emci	EMC184045SE	980409	Mar. 21, 2021
11	EXA Spectrum Analyzer	Keysight	N9010A	MY56480579	Mar. 21, 2021
12	Test Cable	emci	EMC102-KM-KM-800	170654	Mar. 21, 2021
13	Test Cable	emci	Super Reliable-40G-SS11-7000	W0030860001	Mar. 21, 2021
14	Measurement Software	Farad	EZ-EMC Ver.NB-03A1-01	N/A	N/A

Bandwidth					
Item	Kind of Equipment	Manufacturer	Type No.	Serial No.	Calibrated until
1	Spectrum Analyzer	R&S	FSP40	100626	Mar. 06, 2021

Maximum Output Power					
Item	Kind of Equipment	Manufacturer	Type No.	Serial No.	Calibrated until
1	Peak Power Analyze	Keysight	8990B	MY51000507	Mar. 21, 2021
2	Wideband Power Sensor	Keysight	N9123A	MY58310003	Mar. 21, 2021

Antenna Conducted Spurious Emissions					
Item	Kind of Equipment	Manufacturer	Type No.	Serial No.	Calibrated until
1	Spectrum Analyzer	R&S	FSP40	100626	Mar. 06, 2021

Power Spectral Density					
Item	Kind of Equipment	Manufacturer	Type No.	Serial No.	Calibrated until
1	Spectrum Analyzer	R&S	FSP40	100626	Mar. 06, 2021

Remark: "N/A" denotes no model name, serial no. or calibration specified.

All calibration period of equipment list is one year.

10. EUT TEST PHOTO**Conducted Emissions Test Photos**

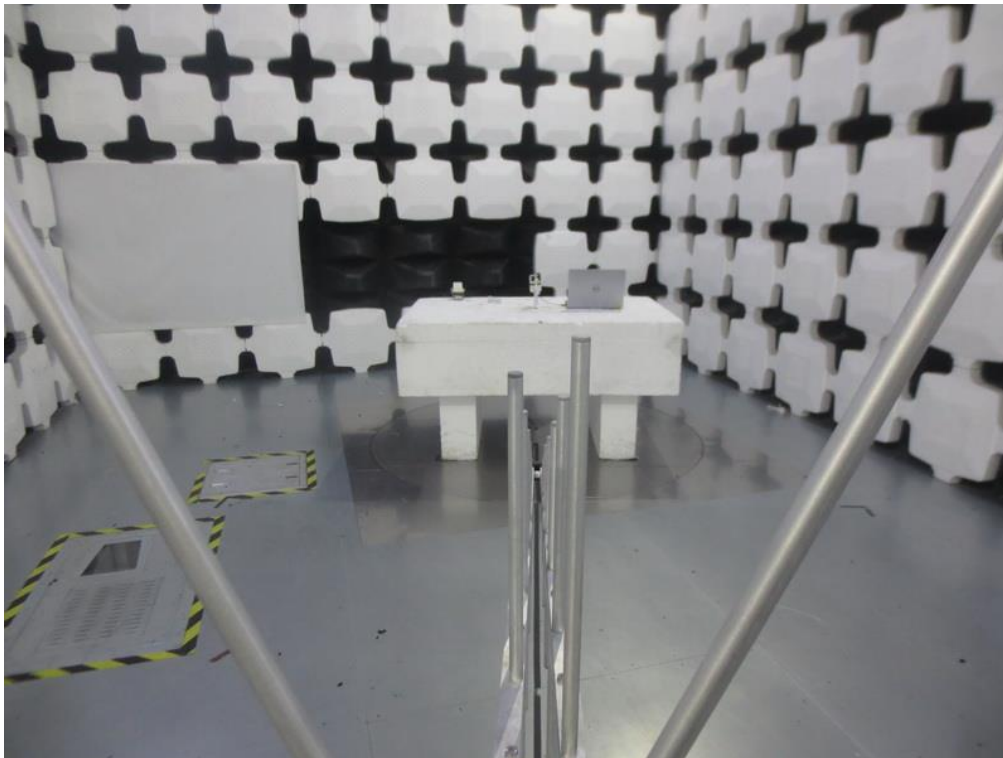
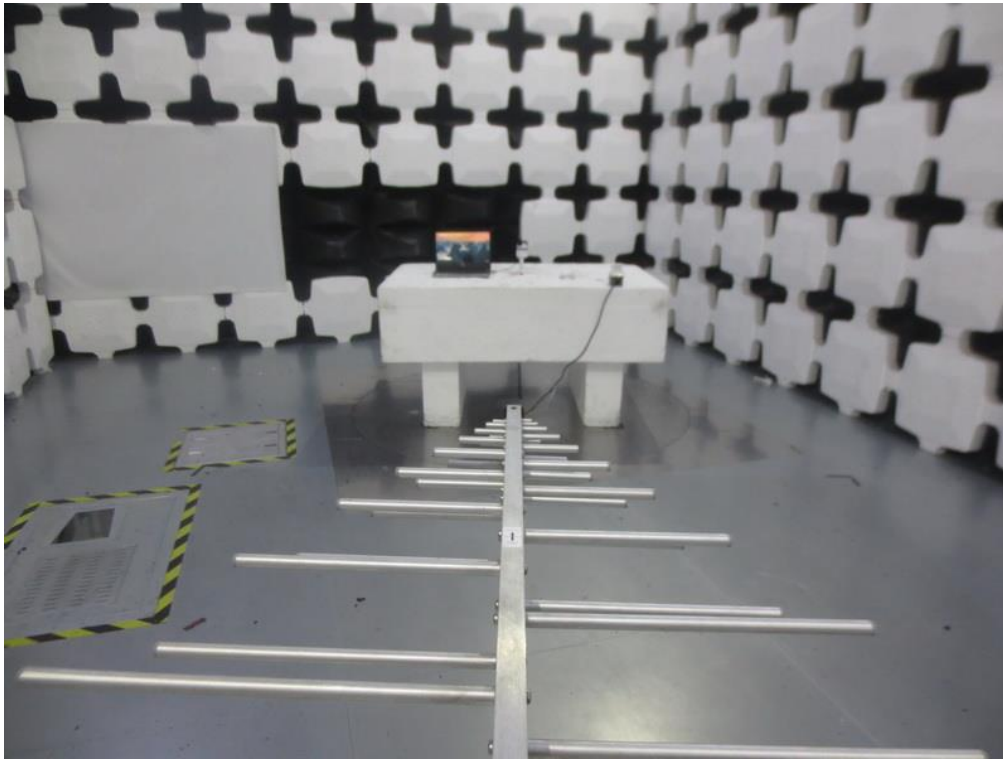
Radiated Emissions Test Photos**30 MHz to 1 GHz**

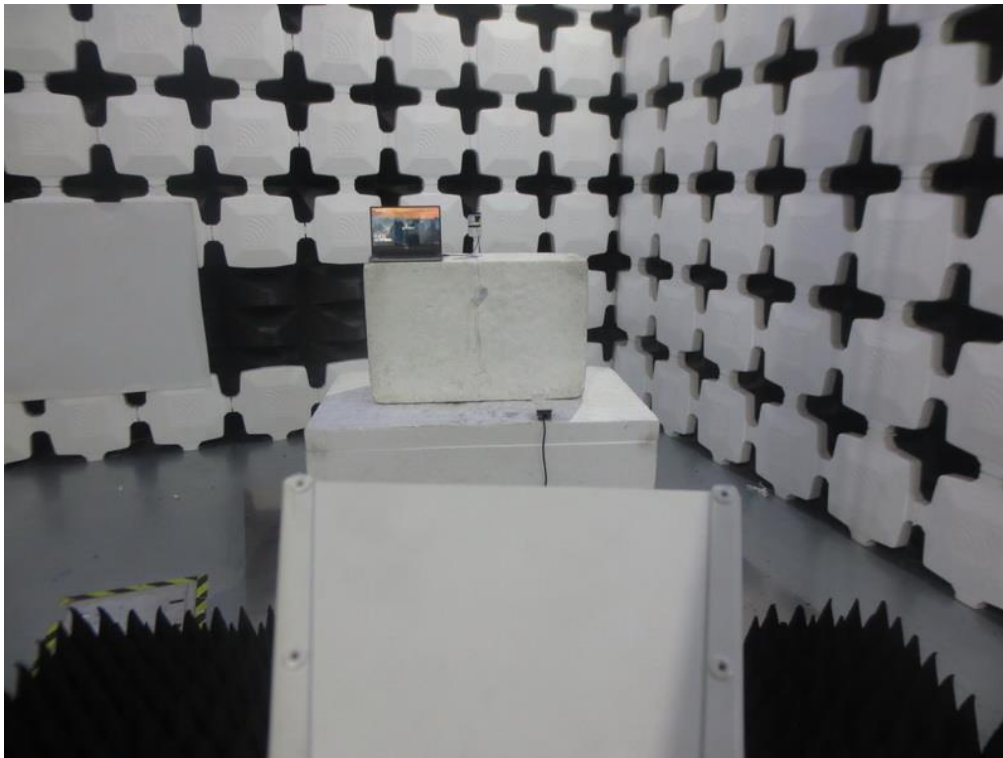
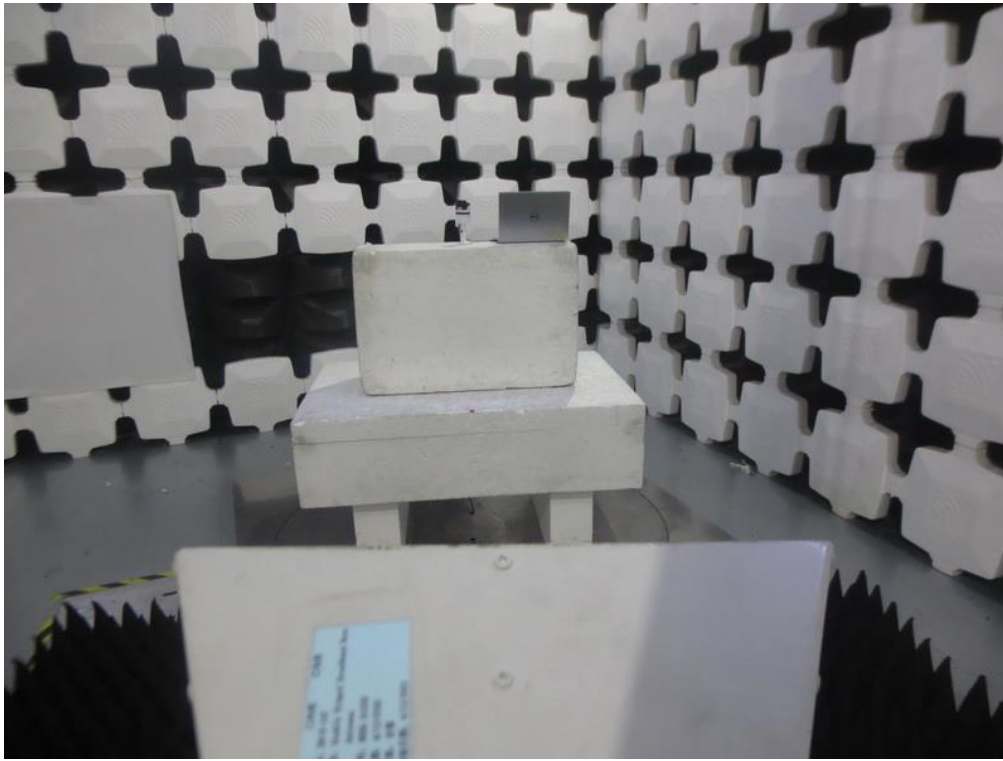
Radiated Emissions Test Photos**Above 1 GHz**

APPENDIX A - AC POWER LINE CONDUCTED EMISSIONS

Test Mode: TX N20 Mode Channel 03

Line

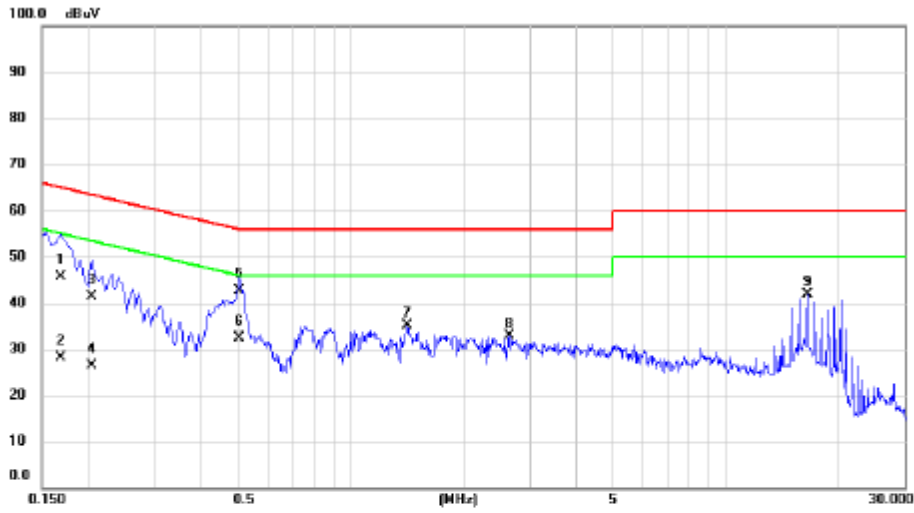

No.	Mk.	Freq.	Reading Level	Correct Factor	Measurement	Limit	Margin	Detector	Comment
		MHz	dBuV	dB	dBuV	dBuV	dB		
1		0.1680	35.80	9.74	45.54	65.06	-19.52	QP	
2		0.1680	18.50	9.74	28.24	55.06	-26.82	AVG	
3		0.2040	31.50	9.78	41.28	63.45	-22.17	QP	
4		0.2040	16.70	9.78	26.48	53.45	-26.97	AVG	
5	*	0.5055	32.80	9.90	42.70	56.00	-13.30	QP	
6		0.5055	22.40	9.90	32.30	46.00	-13.70	AVG	
7		1.4144	25.30	9.76	35.06	56.00	-20.94	peak	
8		2.6430	23.06	9.84	32.90	56.00	-23.10	peak	
9		16.4760	31.50	10.30	41.80	60.00	-18.20	peak	

REMARKS:

- (1) Measurement Value = Reading Level + Correct Factor.
- (2) Margin Level = Measurement Value - Limit Value.

Test Mode: TX N20 Mode Channel 03

Neutral

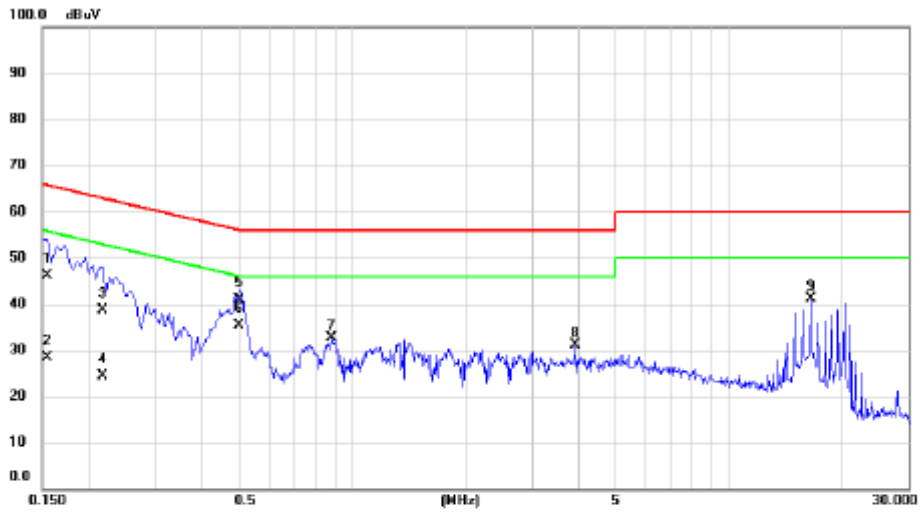

No. Mk.	Freq. MHz	Reading Level dBuV	Correct Factor dB	Measurement dBuV	Limit dBuV	Margin dB	Detector	Comment
1	0.1545	36.40	9.61	46.01	65.75	-19.74	QP	
2	0.1545	18.80	9.61	28.41	55.75	-27.34	AVG	
3	0.2175	29.10	9.63	38.73	62.91	-24.18	QP	
4	0.2175	14.70	9.63	24.33	52.91	-28.58	AVG	
5	0.5010	31.20	9.69	40.89	56.00	-15.11	QP	
6 *	0.5010	25.80	9.69	35.49	46.00	-10.51	AVG	
7	0.8834	22.79	9.72	32.51	56.00	-23.49	peak	
8	3.9210	21.32	9.90	31.22	56.00	-24.78	peak	
9	16.4670	30.79	10.24	41.03	60.00	-18.97	peak	

REMARKS:

(1) Measurement Value = Reading Level + Correct Factor.

(2) Margin Level = Measurement Value - Limit Value.

APPENDIX B - RADIATED EMISSION - 9 KHZ TO 30 MHZ

Note: The measured value have enough margin over 20dB than the limit, therefore they are not reported.

APPENDIX C - RADIATED EMISSION - 30 MHZ TO 1000 MHZ

Test Mode: TX N20 Mode Channel 03

Vertical

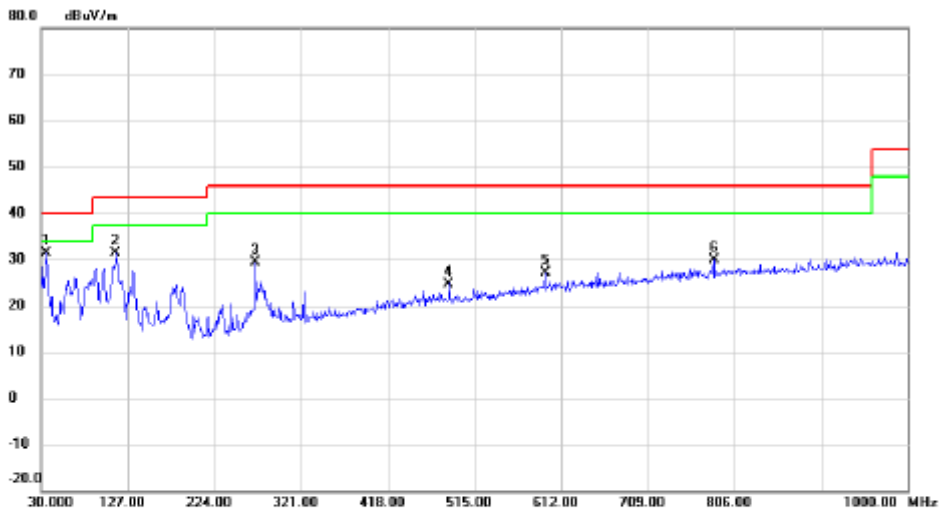

No.	Mk.	Freq. MHz	Reading Level dBuV	Correct Factor dB	Measure- ment dBuV/m	Limit dBuV/m	Margin dB	Detector	Comment
1	*	35.3350	49.26	-17.84	31.42	40.00	-8.58	peak	
2		113.9050	50.24	-18.84	31.40	43.50	-12.10	peak	
3		270.0750	45.18	-15.84	29.34	46.00	-16.66	peak	
4		485.9000	35.32	-10.57	24.75	46.00	-21.25	peak	
5		594.0550	35.43	-8.28	27.15	46.00	-18.85	peak	
6		783.2050	35.14	-5.36	29.78	46.00	-16.22	peak	

REMARKS:

- (1) Measurement Value = Reading Level + Correct Factor.
- (2) Margin Level = Measurement Value - Limit Value.

Test Mode: TX N20 Mode Channel 03

Horizontal

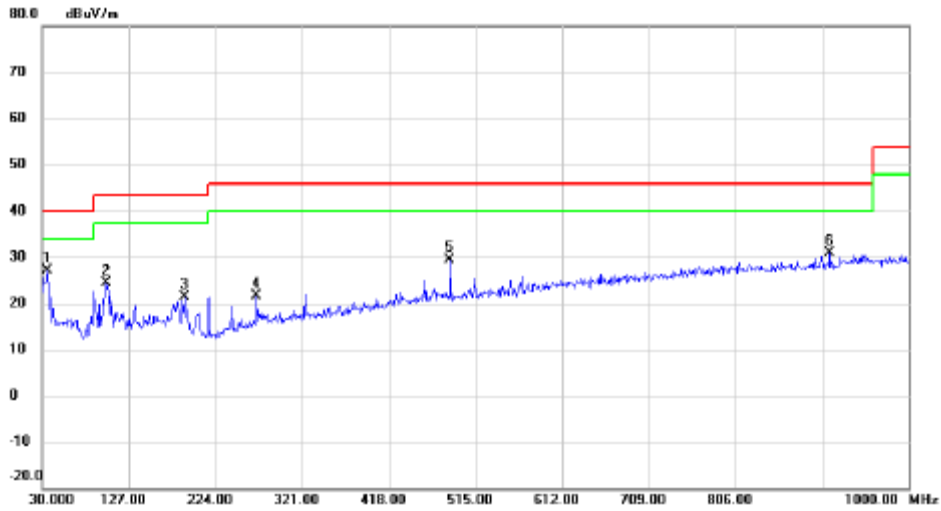

No.	Mk.	Freq. MHz	Reading Level dBuV	Correct Factor dB	Measure- ment dBuV/m	Limit dBuV/m	Margin dB	Detector	Comment
1	*	35.8200	44.77	-17.75	27.02	40.00	-12.98	peak	
2		101.7800	44.84	-20.45	24.39	43.50	-19.11	peak	
3		189.0800	39.29	-17.84	21.45	43.50	-22.05	peak	
4		270.0750	37.37	-15.84	21.53	46.00	-24.47	peak	
5		495.9000	39.96	-10.57	29.39	46.00	-16.61	peak	
6		911.7300	34.96	-4.19	30.77	46.00	-15.23	peak	

REMARKS:

- (1) Measurement Value = Reading Level + Correct Factor.
- (2) Margin Level = Measurement Value - Limit Value.

APPENDIX D - RADIATED EMISSION- ABOVE 1000 MHZ

Test Mode: TX B Mode 2412 MHz

Vertical

120 dBuV/m

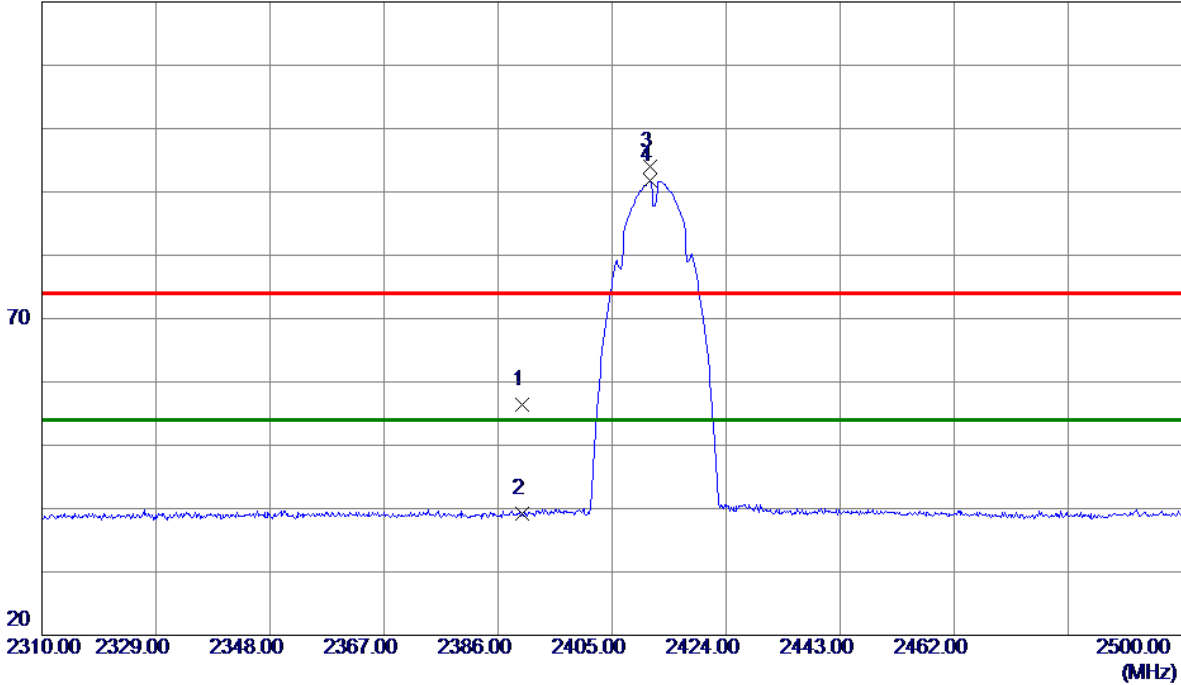

No.	Freq. MHz	Reading Level dBuV/m	Correct Factor dB	Measure ment dBuV/m	Limit dBuV/m	Margin dB	Detector	Comment
1	2390.0000	24.58	31.74	56.32	74.00	-17.68	Peak	
2	2390.0000	7.55	31.74	39.29	54.00	-14.71	AVG	
3	2411.2700	62.28	31.72	94.00	74.00	20.00	Peak	NO Limt
4 *	2411.2700	60.05	31.72	91.77	54.00	37.77	AVG	NO Limt

REMARKS:

- (1) Measurement Value = Reading Level + Correct Factor.
- (2) Margin Level = Measurement Value - Limit Value.

Test Mode: TX B Mode 2412 MHz

Vertical

80 dBuV/m

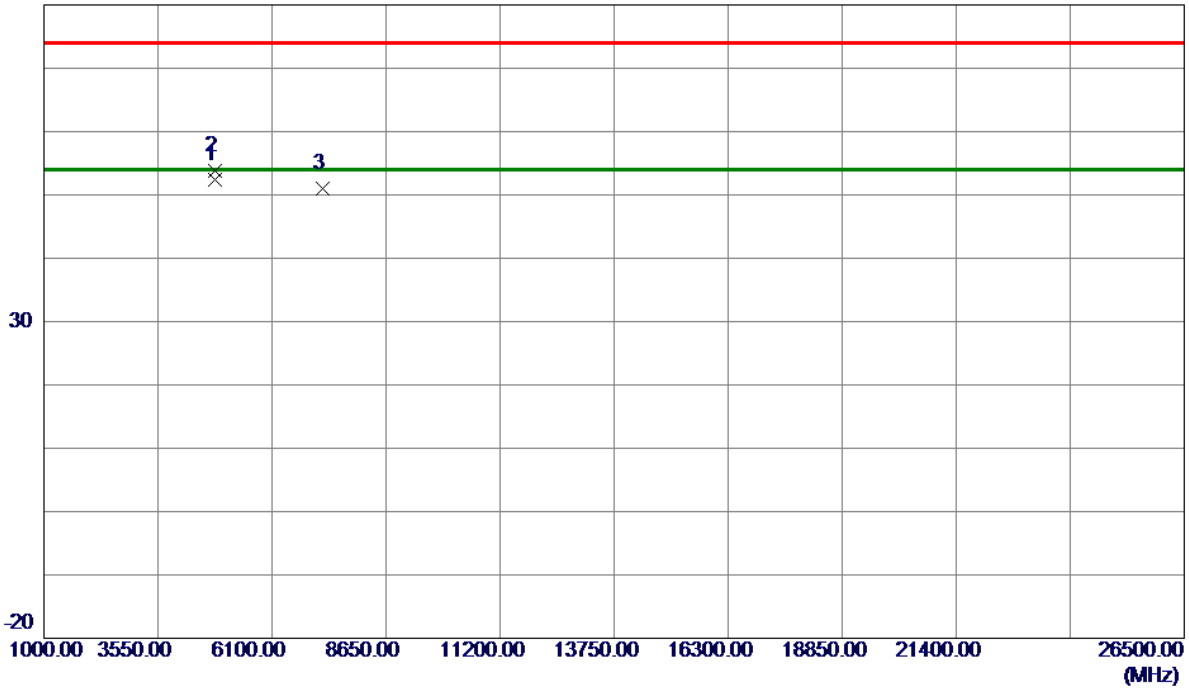

No.	Freq. MHz	Reading Level dBuV/m	Correct Factor dB	Measure ment dBuV/m	Limit dBuV/m	Margin dB	Detector	Comment
1 *	4824.0370	63.30	-10.91	52.39	54.00	-1.61	AVG	
2	4825.0000	64.72	-10.90	53.82	74.00	-20.18	Peak	
3	7237.3000	55.16	-4.17	50.99	74.00	-23.01	Peak	

REMARKS:

- (1) Measurement Value = Reading Level + Correct Factor.
- (2) Margin Level = Measurement Value - Limit Value.

Test Mode: TX B Mode 2412 MHz

Horizontal

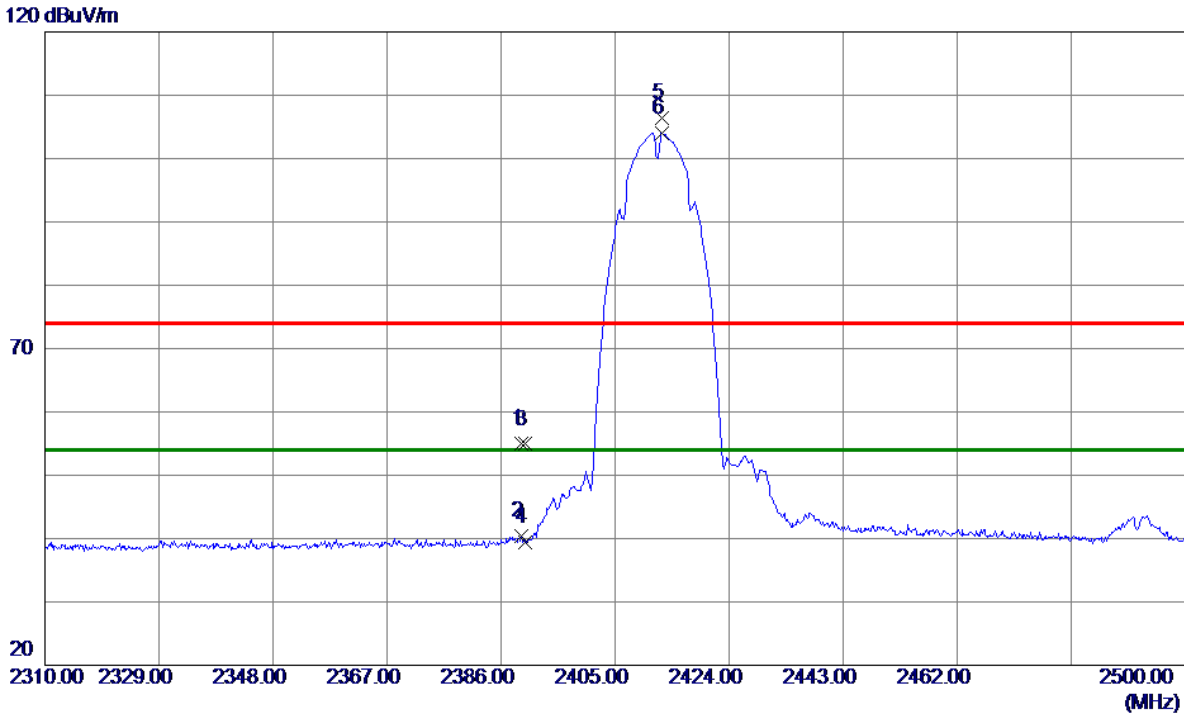

No.	Freq. MHz	Reading Level dBuV/m	Correct Factor dB	Measure ment dBuV/m	Limit dBuV/m	Margin dB	Detector	Comment
1	2389.4200	23.26	31.74	55.00	74.00	-19.00	Peak	
2	2389.4200	8.74	31.74	40.48	54.00	-13.52	AVG	
3	2390.0000	23.16	31.74	54.90	74.00	-19.10	Peak	
4	2390.0000	7.67	31.74	39.41	54.00	-14.59	AVG	
5	2412.7900	74.63	31.72	106.35	74.00	32.35	Peak	NO Limit
6 *	2412.7900	72.31	31.72	104.03	54.00	50.03	AVG	NO Limit

REMARKS:

- (1) Measurement Value = Reading Level + Correct Factor.
- (2) Margin Level = Measurement Value - Limit Value.

Test Mode: TX B Mode 2412 MHz

Horizontal

80 dBuV/m

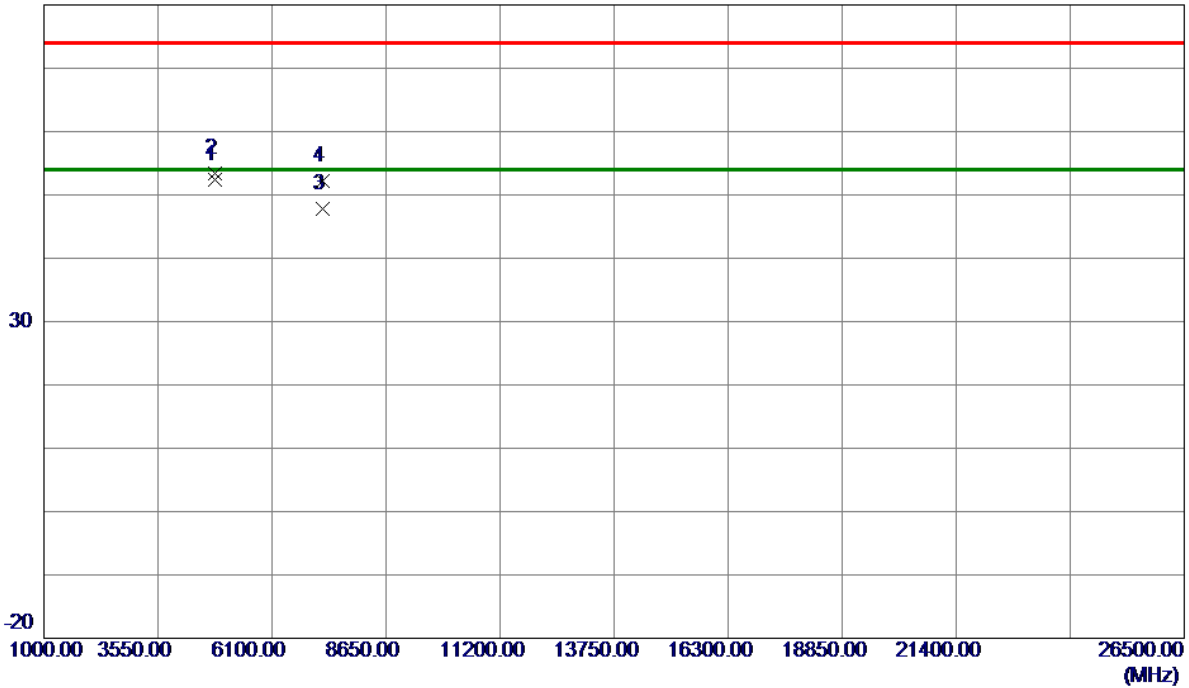

No.	Freq. MHz	Reading Level dBuV/m	Correct Factor dB	Measure ment dBuV/m	Limit dBuV/m	Margin dB	Detector	Comment
1 *	4824.0520	63.31	-10.91	52.40	54.00	-1.60	AVG	
2	4825.0000	64.31	-10.90	53.41	74.00	-20.59	Peak	
3	7236.8340	51.99	-4.17	47.82	54.00	-6.18	AVG	
4	7237.3000	56.43	-4.17	52.26	74.00	-21.74	Peak	

REMARKS:

- (1) Measurement Value = Reading Level + Correct Factor.
- (2) Margin Level = Measurement Value - Limit Value.

Test Mode: TX B Mode 2437 MHz

Vertical

120 dBuV/m

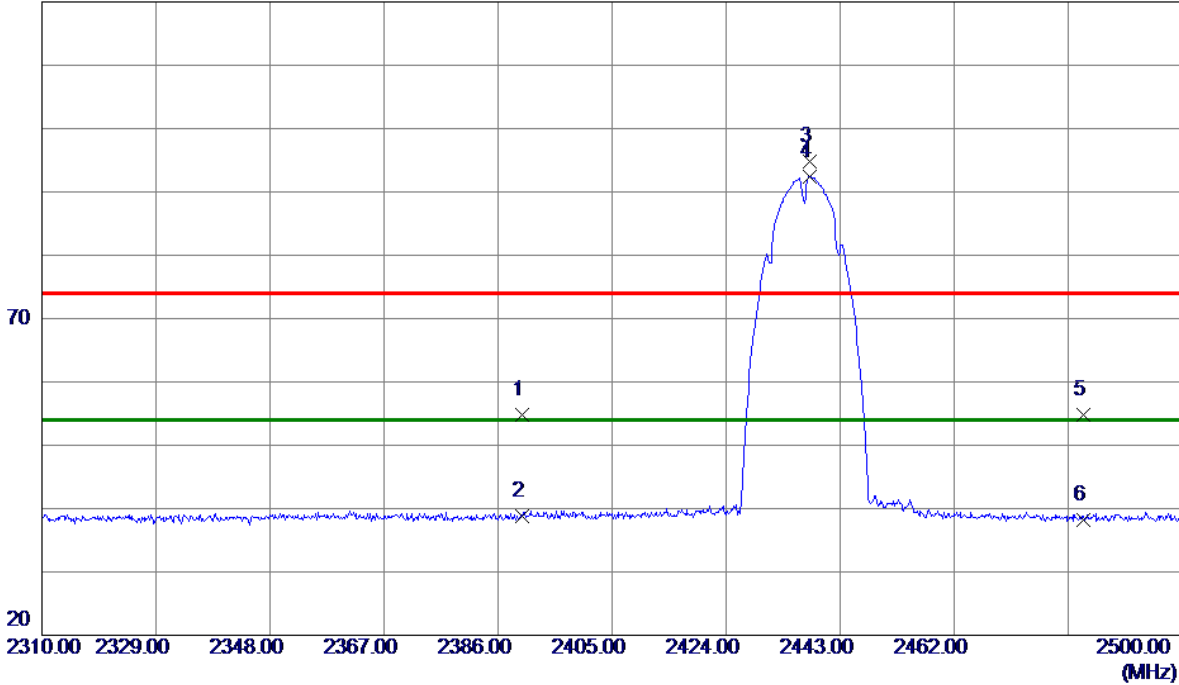

No.	Freq. MHz	Reading Level dBuV/m	Correct Factor dB	Measure ment dBuV/m	Limit dBuV/m	Margin dB	Detector	Comment
1	2390.0000	23.01	31.74	54.75	74.00	-19.25	Peak	
2	2390.0000	7.06	31.74	38.80	54.00	-15.20	AVG	
3	2437.8700	63.04	31.72	94.76	74.00	20.76	Peak	NO Limit
4 *	2437.8700	60.77	31.72	92.49	54.00	38.49	AVG	NO Limit
5	2483.5000	23.08	31.71	54.79	74.00	-19.21	Peak	
6	2483.5000	6.49	31.71	38.20	54.00	-15.80	AVG	

REMARKS:

- (1) Measurement Value = Reading Level + Correct Factor.
- (2) Margin Level = Measurement Value - Limit Value.

Test Mode: TX B Mode 2437 MHz

Vertical

80 dBuV/m

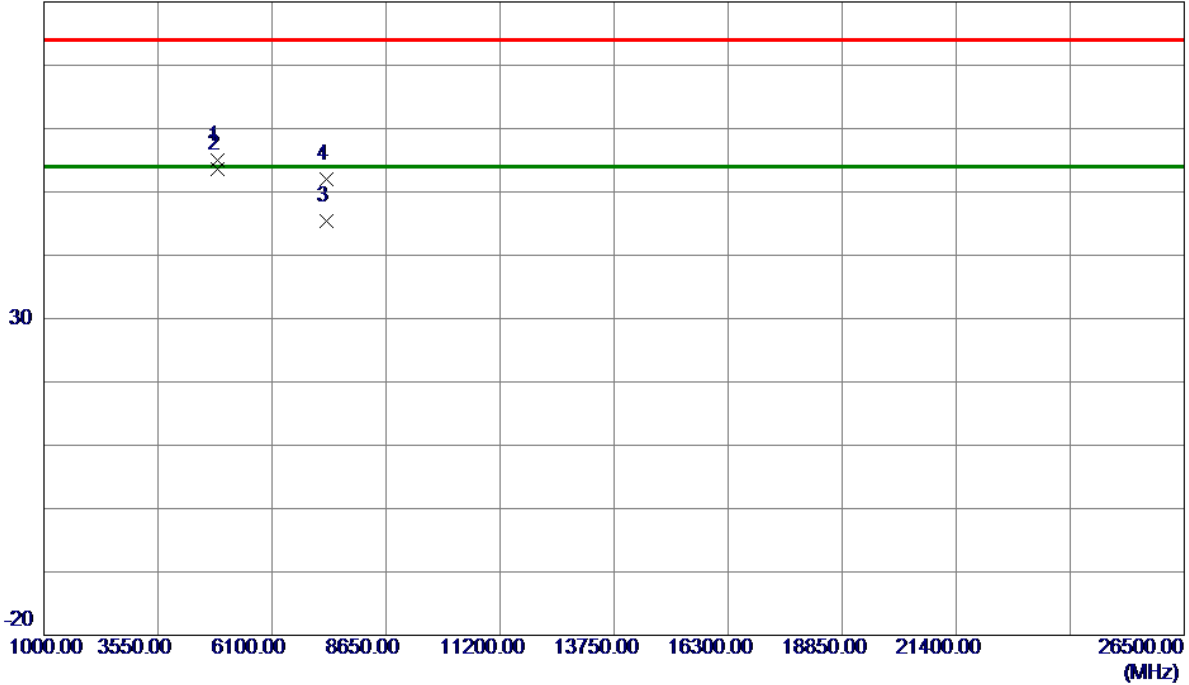

No.	Freq. MHz	Reading Level dBuV/m	Correct Factor dB	Measure ment dBuV/m	Limit dBuV/m	Margin dB	Detector	Comment
1	4873.4500	65.85	-10.79	55.06	74.00	-18.94	Peak	
2 *	4874.0259	64.34	-10.79	53.55	54.00	-0.45	AVG	
3	7310.2250	49.55	-4.08	45.47	54.00	-8.53	AVG	
4	7311.2500	56.00	-4.07	51.93	74.00	-22.07	Peak	

REMARKS:

- (1) Measurement Value = Reading Level + Correct Factor.
- (2) Margin Level = Measurement Value - Limit Value.

Test Mode: TX B Mode 2437 MHz

Horizontal

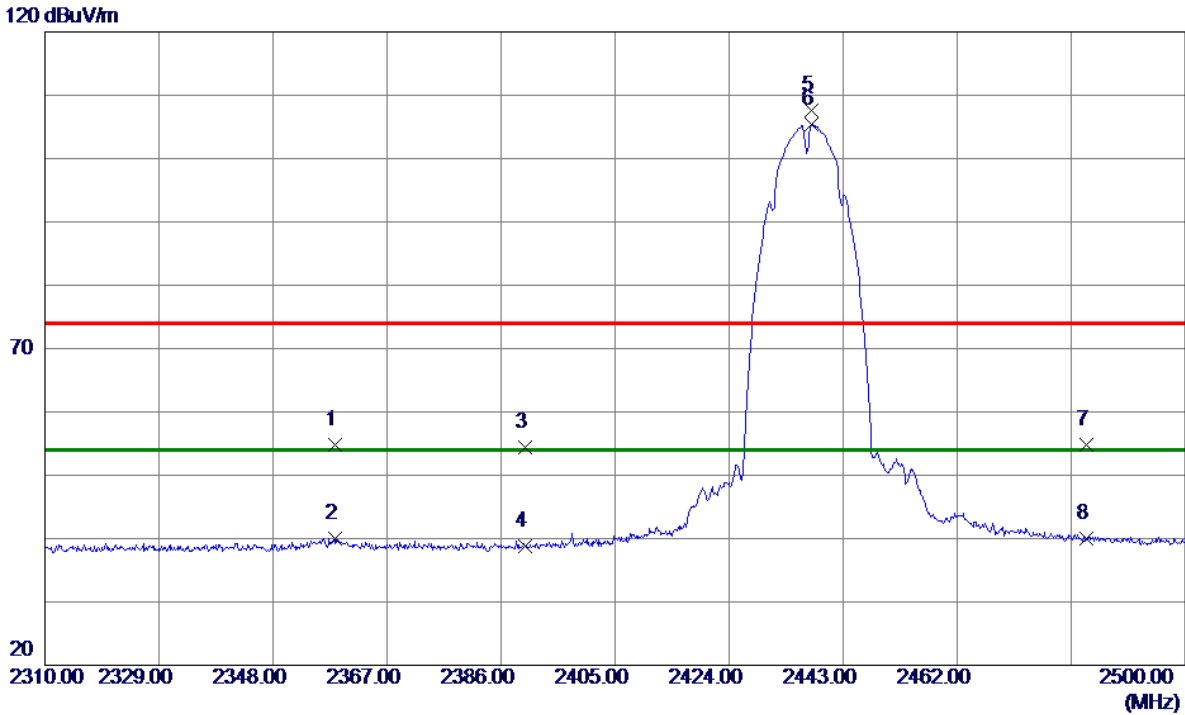

No.	Freq. MHz	Reading Level dBuV/m	Correct Factor dB	Measure ment dBuV/m	Limit dBuV/m	Margin dB	Detector	Comment
1	2358.2600	23.07	31.80	54.87	74.00	-19.13	Peak	
2	2358.2600	8.29	31.80	40.09	74.00	-33.91	Peak	
3	2390.0000	22.70	31.74	54.44	74.00	-19.56	Peak	
4	2390.0000	7.06	31.74	38.80	54.00	-15.20	AVG	
5	2437.7750	75.88	31.72	107.60	74.00	33.60	Peak	NO Limit
6 *	2437.7750	73.68	31.72	105.40	54.00	51.40	AVG	NO Limit
7	2483.5000	23.04	31.71	54.75	74.00	-19.25	Peak	
8	2483.5000	8.22	31.71	39.93	54.00	-14.07	AVG	

REMARKS:

- (1) Measurement Value = Reading Level + Correct Factor.
- (2) Margin Level = Measurement Value - Limit Value.

Test Mode: TX B Mode 2437 MHz

Horizontal

80 dBuV/m

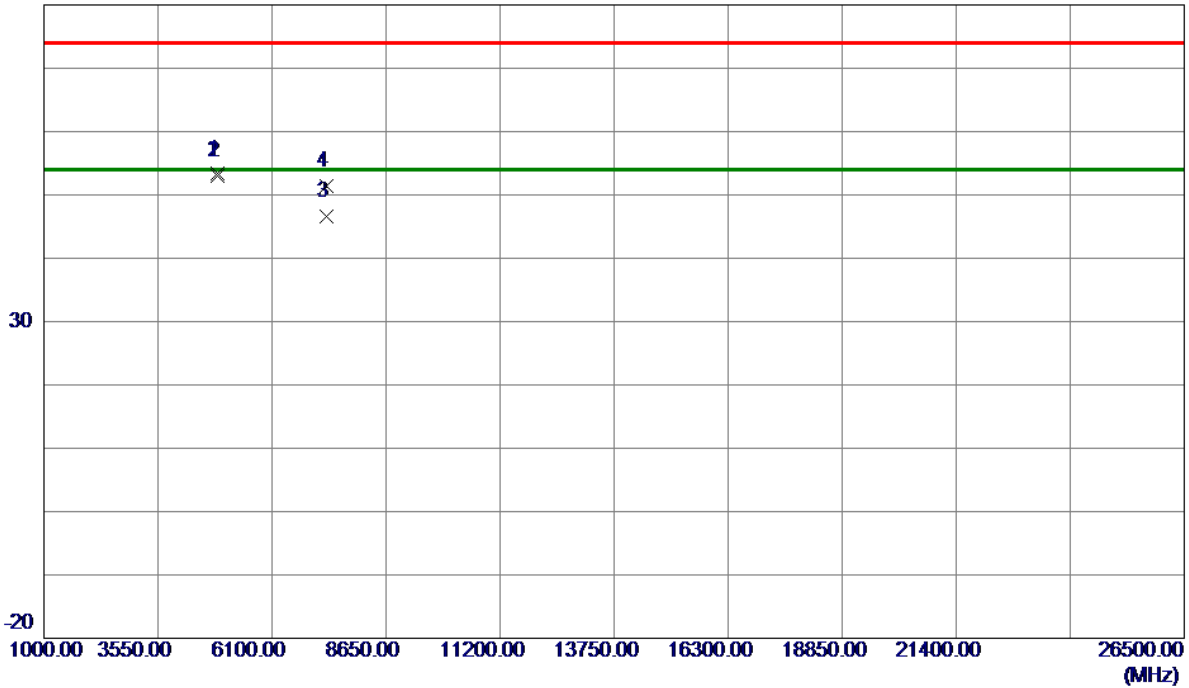

No.	Freq. MHz	Reading Level dBuV/m	Correct Factor dB	Measure ment dBuV/m	Limit dBuV/m	Margin dB	Detector	Comment
1	4873.4500	64.09	-10.79	53.30	74.00	-20.70	Peak	
2 *	4874.0030	63.73	-10.79	52.94	54.00	-1.06	AVG	
3	7310.1900	50.67	-4.08	46.59	54.00	-7.41	AVG	
4	7311.2500	55.52	-4.07	51.45	74.00	-22.55	Peak	

REMARKS:

(1) Measurement Value = Reading Level + Correct Factor.

(2) Margin Level = Measurement Value - Limit Value.

Test Mode: TX B Mode 2462 MHz

Vertical

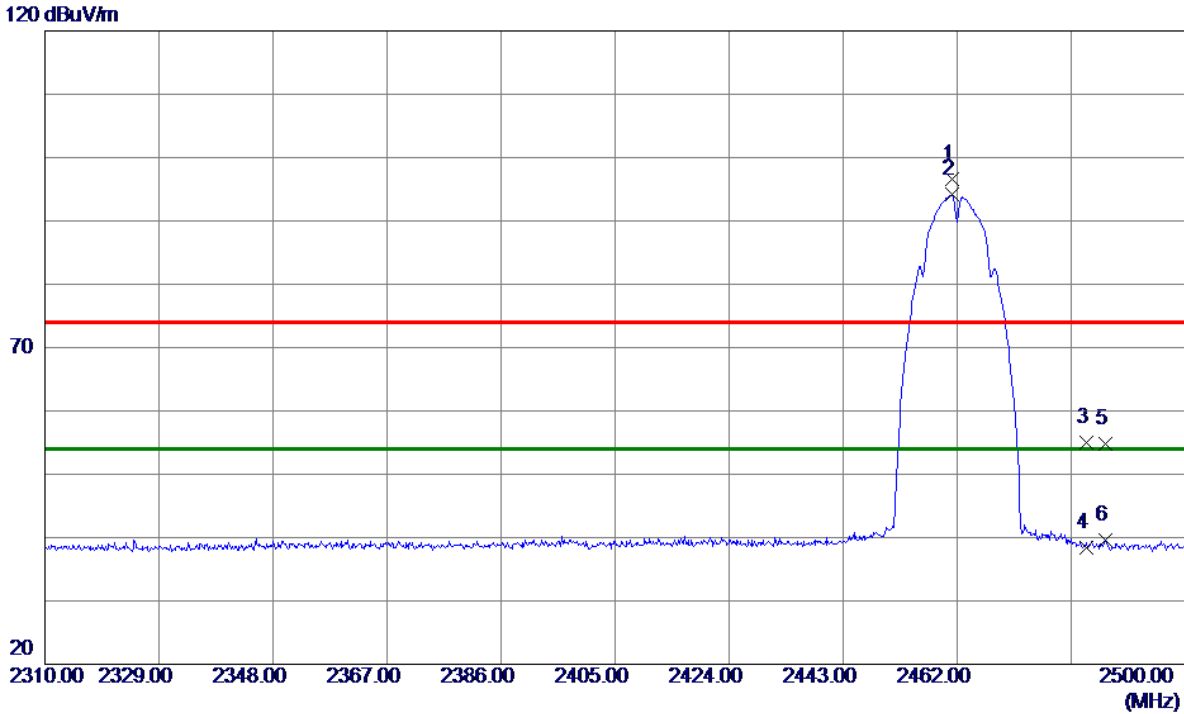

No.	Freq. MHz	Reading Level dBuV/m	Correct Factor dB	Measure ment dBuV/m	Limit dBuV/m	Margin dB	Detector	Comment
1	2461.2400	64.86	31.71	96.57	74.00	22.57	Peak	NO Limt
2 *	2461.2400	62.51	31.71	94.22	54.00	40.22	AVG	NO Limt
3	2483.5000	23.24	31.71	54.95	74.00	-19.05	Peak	
4	2483.5000	6.66	31.71	38.37	54.00	-15.63	AVG	
5	2486.7950	23.04	31.71	54.75	74.00	-19.25	Peak	
6	2486.7950	7.87	31.71	39.58	54.00	-14.42	AVG	

REMARKS:

- (1) Measurement Value = Reading Level + Correct Factor.
- (2) Margin Level = Measurement Value - Limit Value.

Test Mode: TX B Mode 2462 MHz

Vertical

80 dBuV/m

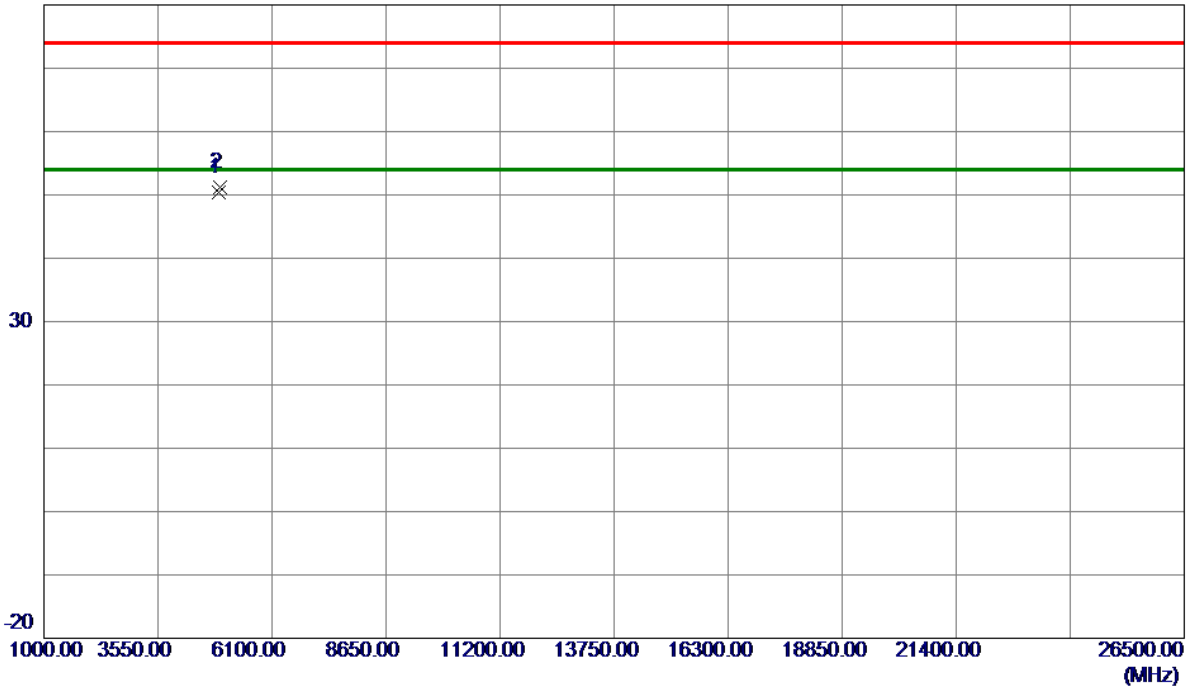

No.	Freq. MHz	Reading Level dBuV/m	Correct Factor dB	Measure ment dBuV/m	Limit dBuV/m	Margin dB	Detector	Comment
1 *	4924.0350	61.09	-10.63	50.46	54.00	-3.54	AVG	
2	4924.4500	61.80	-10.62	51.18	74.00	-22.82	Peak	

REMARKS:

- (1) Measurement Value = Reading Level + Correct Factor.
- (2) Margin Level = Measurement Value - Limit Value.

Test Mode: TX B Mode 2462 MHz

Horizontal

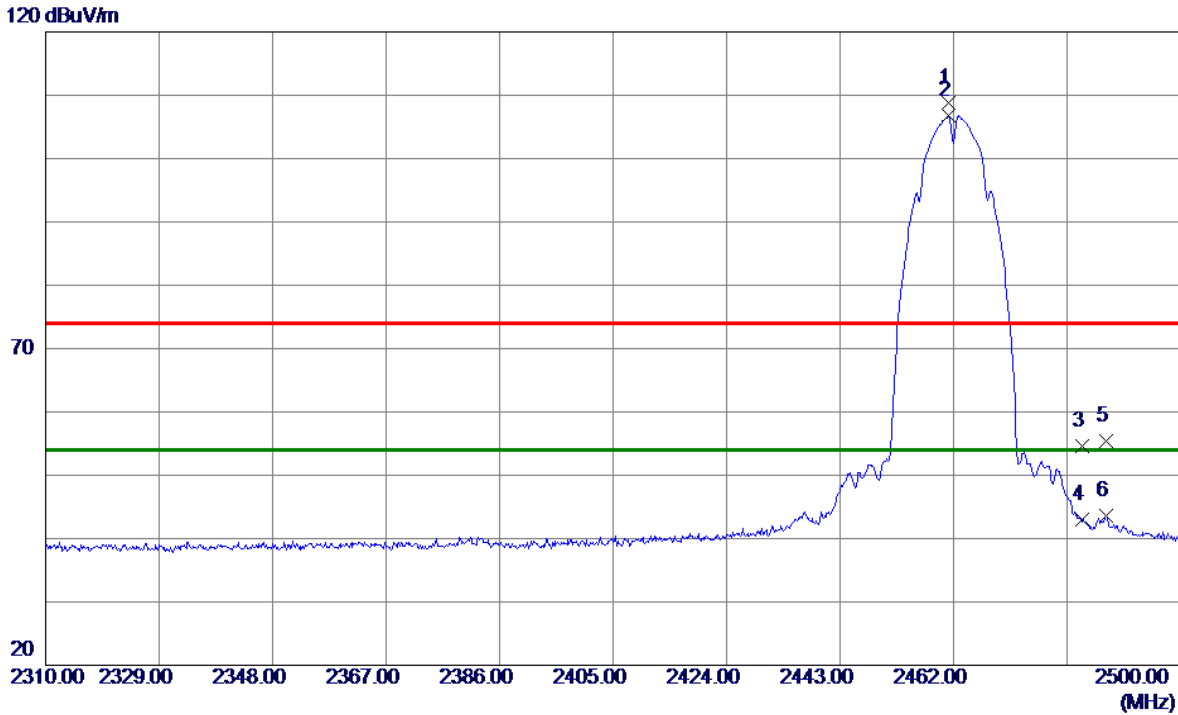

No.	Freq. MHz	Reading Level dBuV/m	Correct Factor dB	Measure ment dBuV/m	Limit dBuV/m	Margin dB	Detector	Comment
1	2461.2400	76.99	31.71	108.70	74.00	34.70	Peak	NO Limt
2 *	2461.2400	75.02	31.71	106.73	54.00	52.73	AVG	NO Limt
3	2483.5000	22.84	31.71	54.55	74.00	-19.45	Peak	
4	2483.5000	11.23	31.71	42.94	54.00	-11.06	AVG	
5	2487.4600	23.67	31.71	55.38	74.00	-18.62	Peak	
6	2487.4600	11.90	31.71	43.61	54.00	-10.39	AVG	

REMARKS:

- (1) Measurement Value = Reading Level + Correct Factor.
- (2) Margin Level = Measurement Value - Limit Value.

Test Mode: TX B Mode 2462 MHz

Horizontal

80 dBuV/m

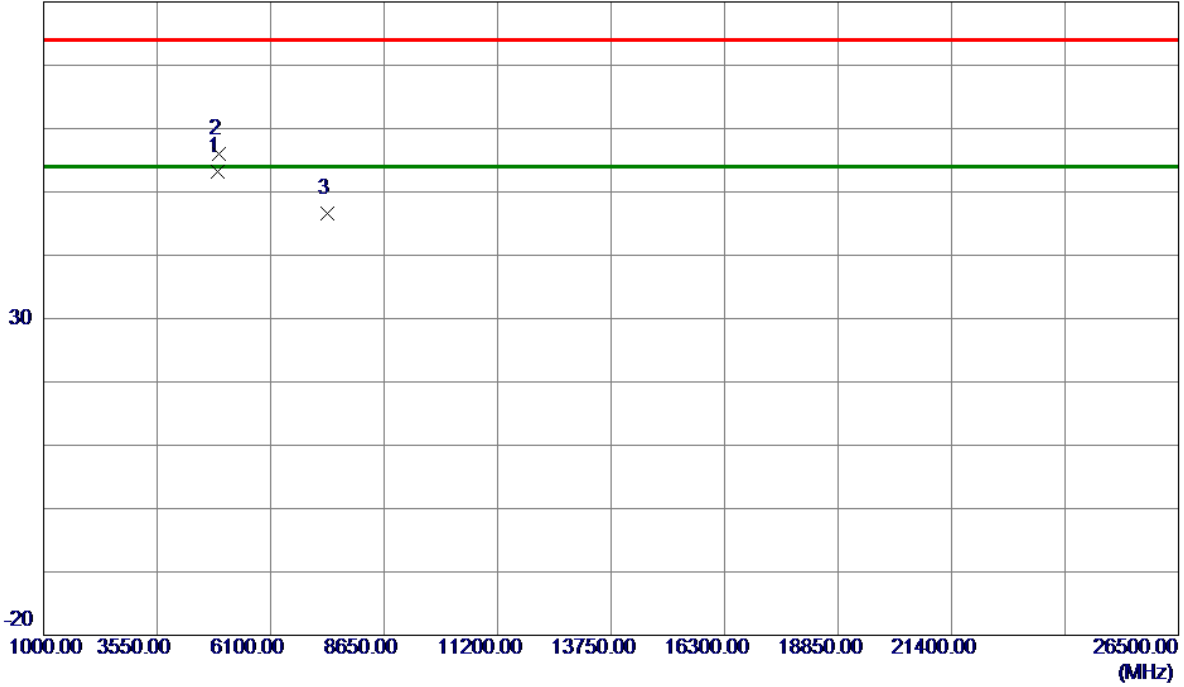

No.	Freq. MHz	Reading Level dBuV/m	Correct Factor dB	Measure ment dBuV/m	Limit dBuV/m	Margin dB	Detector	Comment
1 *	4923.9920	63.88	-10.63	53.25	54.00	-0.75	AVG	
2	4924.4500	66.70	-10.62	56.08	74.00	-17.92	Peak	
3	7385.2000	50.65	-3.98	46.67	74.00	-27.33	Peak	

REMARKS:

(1) Measurement Value = Reading Level + Correct Factor.

(2) Margin Level = Measurement Value - Limit Value.

Test Mode: TX G Mode 2412 MHz

Vertical

120 dBuV/m

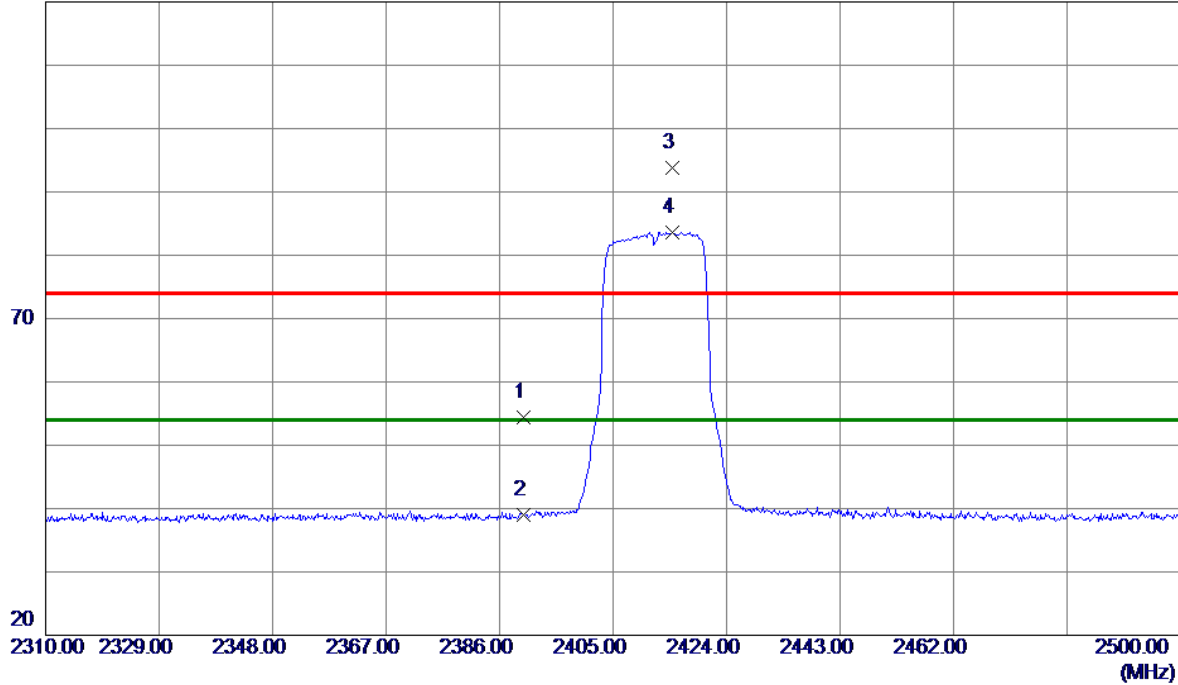

No.	Freq. MHz	Reading Level dBuV/m	Correct Factor dB	Measure ment dBuV/m	Limit dBuV/m	Margin dB	Detector	Comment
1	2390.0000	22.68	31.74	54.42	74.00	-19.58	Peak	
2	2390.0000	7.20	31.74	38.94	54.00	-15.06	AVG	
3	2414.8799	62.06	31.72	93.78	74.00	19.78	Peak	NO Limt
4 *	2414.8799	51.93	31.72	83.65	54.00	29.65	AVG	NO Limt

REMARKS:

- (1) Measurement Value = Reading Level + Correct Factor.
- (2) Margin Level = Measurement Value - Limit Value.

Test Mode: TX G Mode 2412 MHz

Vertical

80 dBuV/m

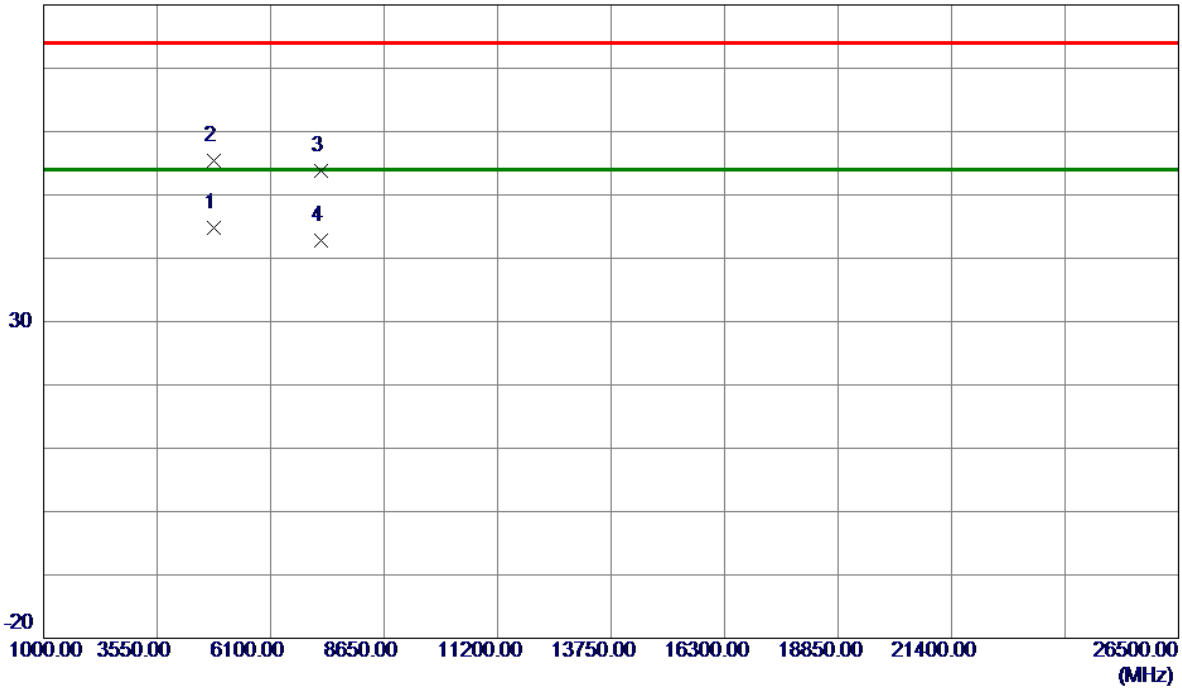

No.	Freq. MHz	Reading Level dBuV/m	Correct Factor dB	Measure ment dBuV/m	Limit dBuV/m	Margin dB	Detector	Comment
1 *	4830.3670	55.70	-10.89	44.81	54.00	-9.19	AVG	
2	4832.6500	66.36	-10.89	55.47	74.00	-18.53	Peak	
3	7227.1000	58.06	-4.18	53.88	74.00	-20.12	Peak	
4	7229.2840	46.95	-4.18	42.77	54.00	-11.23	AVG	

REMARKS:

- (1) Measurement Value = Reading Level + Correct Factor.
- (2) Margin Level = Measurement Value - Limit Value.

Test Mode: TX G Mode 2412 MHz

Horizontal

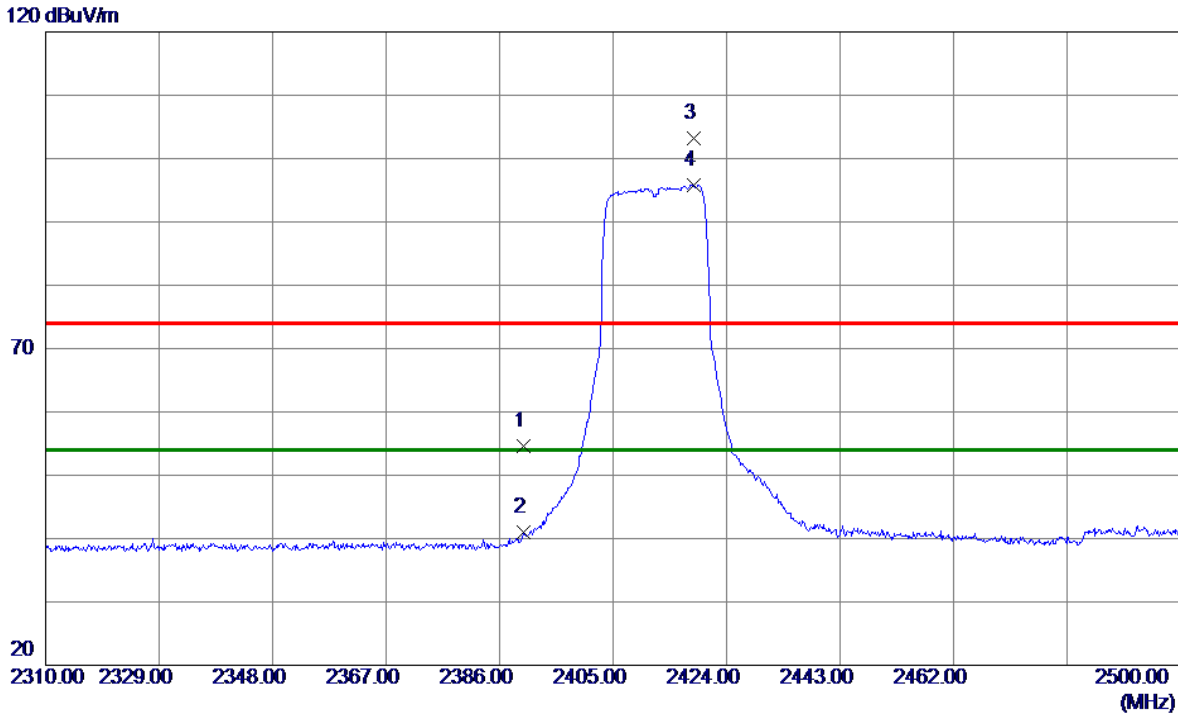

No.	Freq. MHz	Reading Level dBuV/m	Correct Factor dB	Measure ment dBuV/m	Limit dBuV/m	Margin dB	Detector	Comment
1	2390.0000	22.85	31.74	54.59	74.00	-19.41	Peak	
2	2390.0000	9.31	31.74	41.05	54.00	-12.95	AVG	
3	2418.4900	71.53	31.72	103.25	74.00	29.25	Peak	NO Limt
4 *	2418.4900	64.13	31.72	95.85	54.00	41.85	AVG	NO Limt

REMARKS:

- (1) Measurement Value = Reading Level + Correct Factor.
- (2) Margin Level = Measurement Value - Limit Value.

Test Mode: TX G Mode 2412 MHz

Horizontal

80 dBuV/m

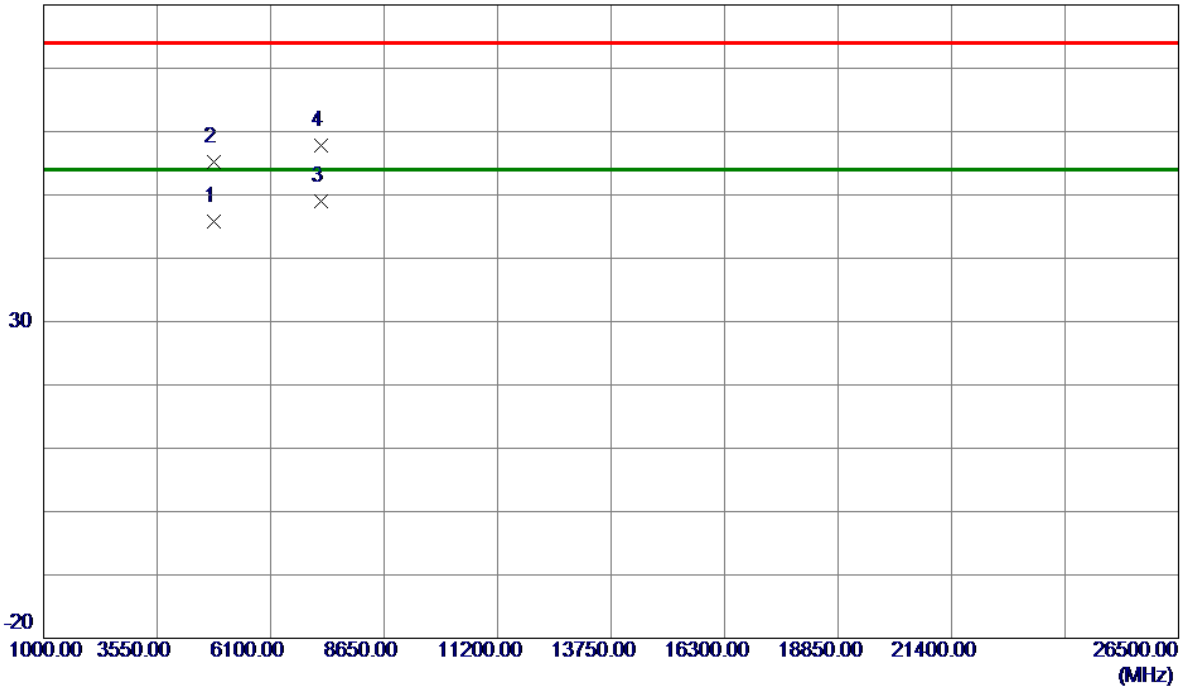

No.	Freq. MHz	Reading Level dBuV/m	Correct Factor dB	Measure ment dBuV/m	Limit dBuV/m	Margin dB	Detector	Comment
1	4823.8470	56.65	-10.91	45.74	54.00	-8.26	AVG	
2	4825.0000	66.16	-10.90	55.26	74.00	-18.74	Peak	
3 *	7237.9100	53.12	-4.17	48.95	54.00	-5.05	AVG	
4	7239.8500	61.91	-4.17	57.74	74.00	-16.26	Peak	

REMARKS:

(1) Measurement Value = Reading Level + Correct Factor.

(2) Margin Level = Measurement Value - Limit Value.

Test Mode: TX G Mode 2437 MHz

Vertical

120 dBuV/m

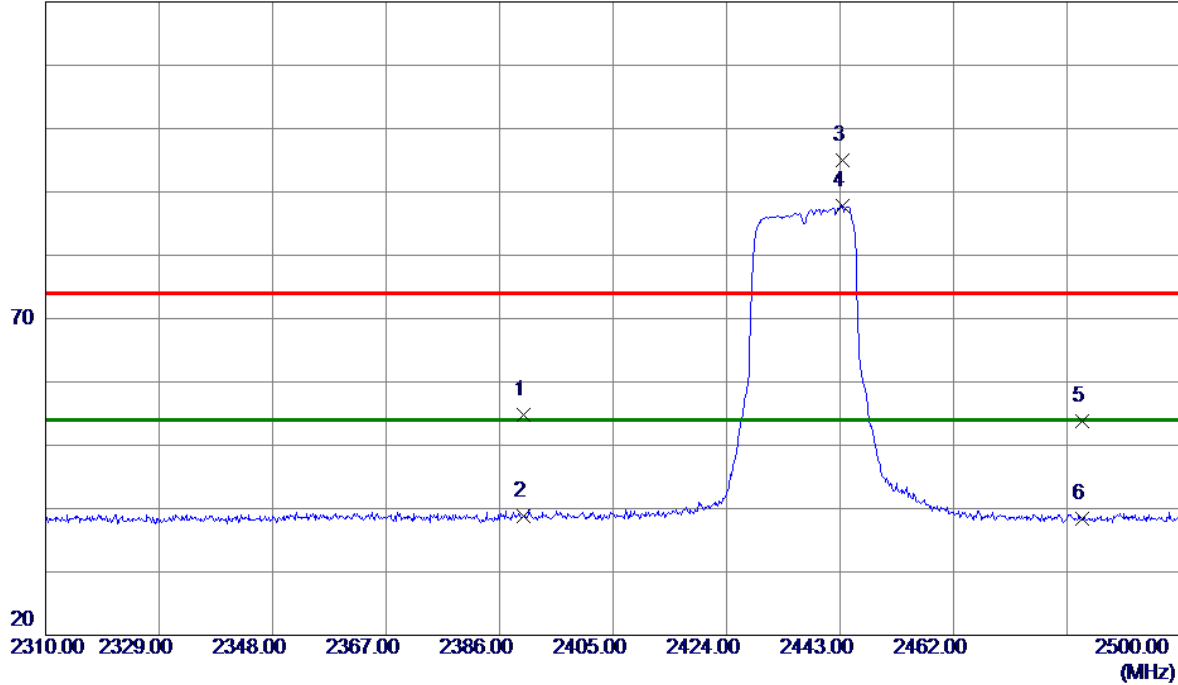

No.	Freq. MHz	Reading Level dBuV/m	Correct Factor dB	Measure ment dBuV/m	Limit dBuV/m	Margin dB	Detector	Comment
1	2390.0000	22.97	31.74	54.71	74.00	-19.29	Peak	
2	2390.0000	6.97	31.74	38.71	54.00	-15.29	AVG	
3	2443.3799	63.26	31.72	94.98	74.00	20.98	Peak	NO Limit
4 *	2443.3799	56.08	31.72	87.80	54.00	33.80	AVG	NO Limit
5	2483.5000	22.12	31.71	53.83	74.00	-20.17	Peak	
6	2483.5000	6.62	31.71	38.33	54.00	-15.67	AVG	

REMARKS:

- (1) Measurement Value = Reading Level + Correct Factor.
- (2) Margin Level = Measurement Value - Limit Value.

Test Mode: TX G Mode 2437 MHz

Vertical

80 dBuV/m

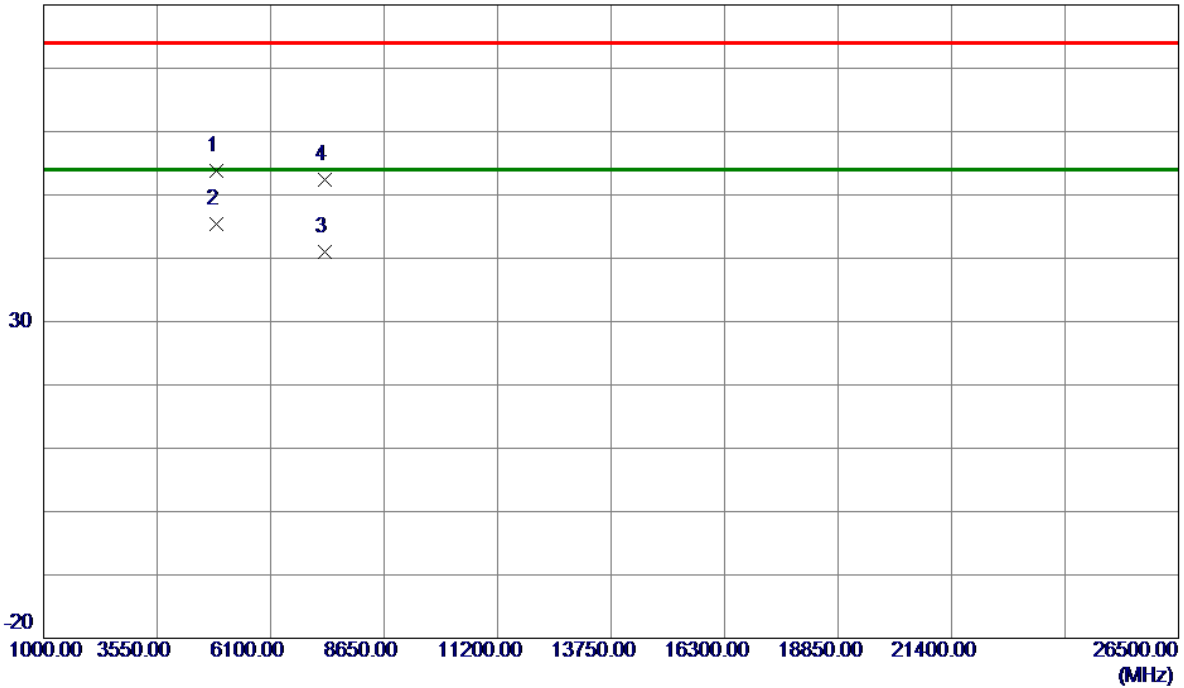

No.	Freq. MHz	Reading Level dBuV/m	Correct Factor dB	Measure ment dBuV/m	Limit dBuV/m	Margin dB	Detector	Comment
1	4873.4500	64.64	-10.79	53.85	74.00	-20.15	Peak	
2 *	4874.2980	56.23	-10.79	45.44	54.00	-8.56	AVG	
3	7308.3200	45.15	-4.08	41.07	54.00	-12.93	AVG	
4	7311.2500	56.48	-4.07	52.41	74.00	-21.59	Peak	

REMARKS:

- (1) Measurement Value = Reading Level + Correct Factor.
- (2) Margin Level = Measurement Value - Limit Value.

Test Mode: TX G Mode 2437 MHz

Horizontal

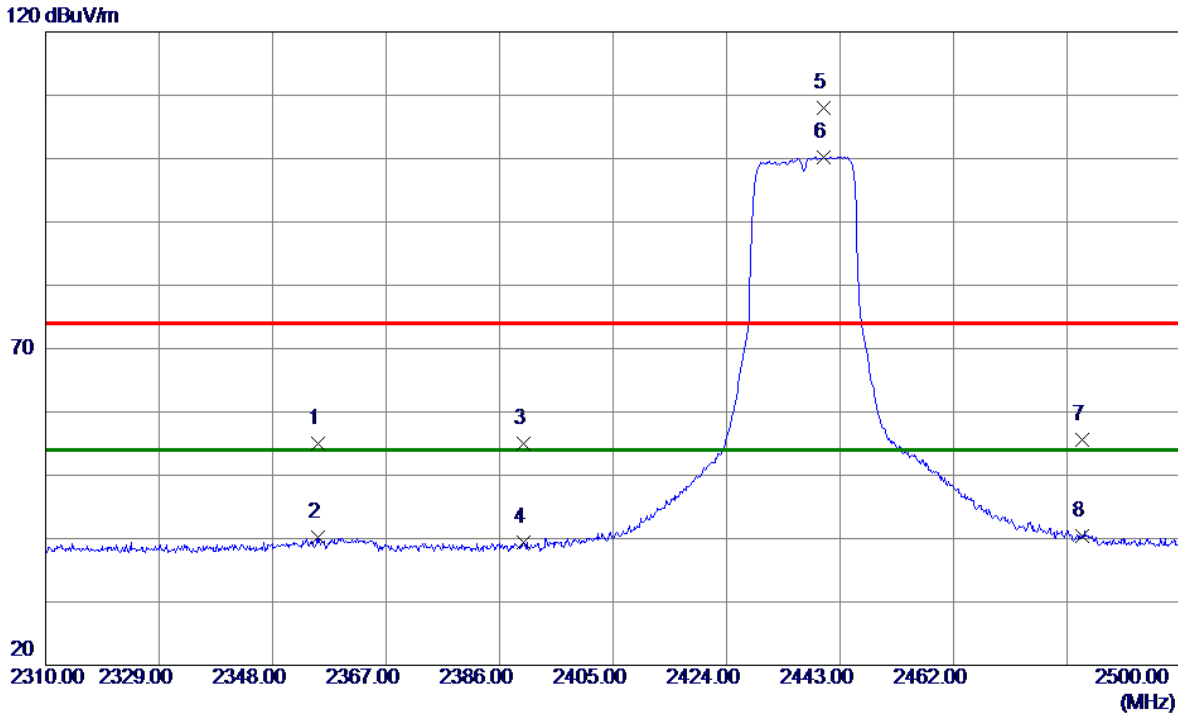

No.	Freq. MHz	Reading Level dBuV/m	Correct Factor dB	Measure ment dBuV/m	Limit dBuV/m	Margin dB	Detector	Comment
1	2355.5049	23.14	31.81	54.95	74.00	-19.05	Peak	
2	2355.5049	8.37	31.81	40.18	54.00	-13.82	AVG	
3	2390.0000	23.17	31.74	54.91	74.00	-19.09	Peak	
4	2390.0000	7.59	31.74	39.33	54.00	-14.67	AVG	
5	2440.3400	76.35	31.72	108.07	74.00	34.07	Peak	NO Limit
6 *	2440.3400	68.56	31.72	100.28	54.00	46.28	AVG	NO Limit
7	2483.5000	23.94	31.71	55.65	74.00	-18.35	Peak	
8	2483.5000	8.75	31.71	40.46	54.00	-13.54	AVG	

REMARKS:

- (1) Measurement Value = Reading Level + Correct Factor.
- (2) Margin Level = Measurement Value - Limit Value.

Test Mode: TX G Mode 2437 MHz

Horizontal

80 dBuV/m

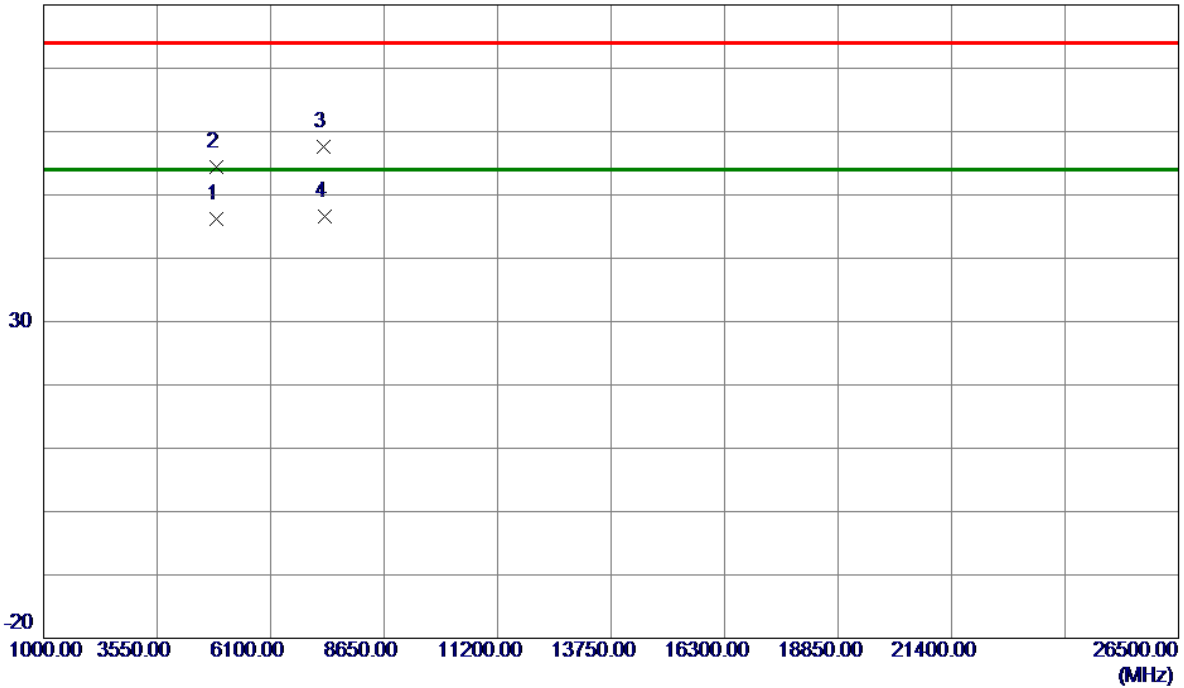

No.	Freq. MHz	Reading Level dBuV/m	Correct Factor dB	Measure ment dBuV/m	Limit dBuV/m	Margin dB	Detector	Comment
1	4874.1990	56.90	-10.79	46.11	54.00	-7.89	AVG	
2	4876.0000	65.17	-10.79	54.38	74.00	-19.62	Peak	
3	7303.6000	61.65	-4.08	57.57	74.00	-16.43	Peak	
4 *	7305.9360	50.76	-4.08	46.68	54.00	-7.32	AVG	

REMARKS:

(1) Measurement Value = Reading Level + Correct Factor.

(2) Margin Level = Measurement Value - Limit Value.

Test Mode: TX G Mode 2462 MHz

Vertical

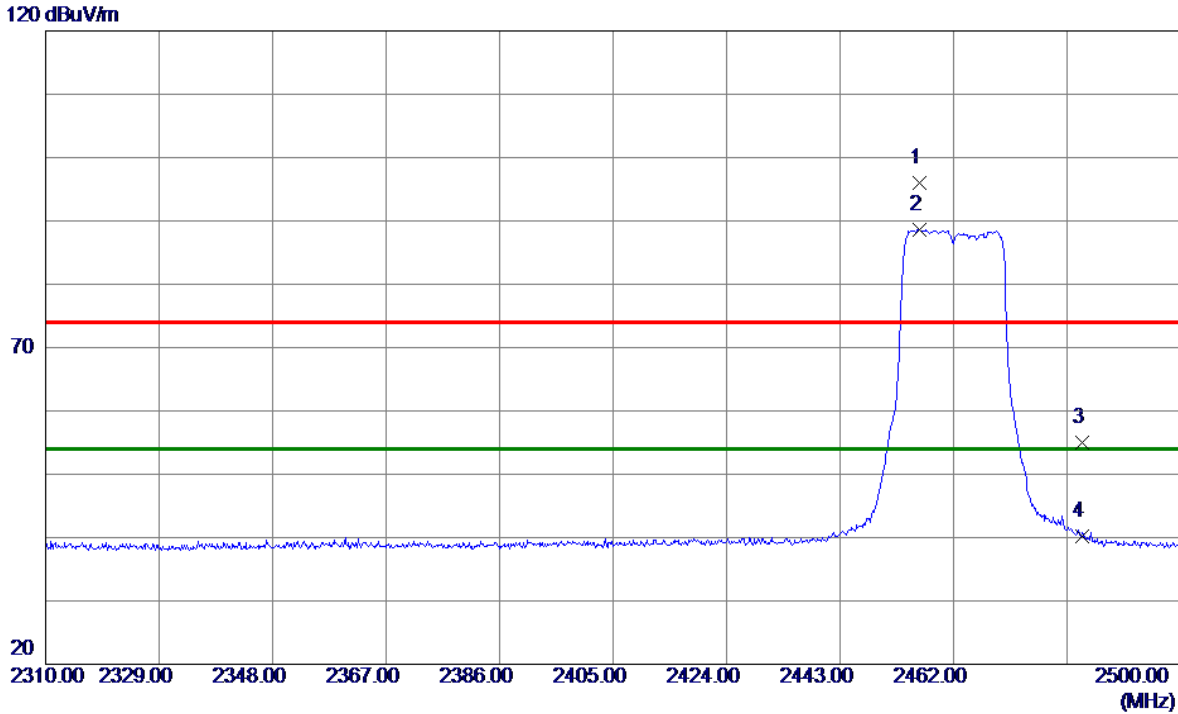

No.	Freq. MHz	Reading Level dBuV/m	Correct Factor dB	Measure ment dBuV/m	Limit dBuV/m	Margin dB	Detector	Comment
1	2456.3000	64.19	31.71	95.90	74.00	21.90	Peak	NO Limt
2 *	2456.3000	56.87	31.71	88.58	54.00	34.58	AVG	NO Limt
3	2483.5000	23.22	31.71	54.93	74.00	-19.07	Peak	
4	2483.5000	8.51	31.71	40.22	54.00	-13.78	AVG	

REMARKS:

- (1) Measurement Value = Reading Level + Correct Factor.
- (2) Margin Level = Measurement Value - Limit Value.

Test Mode: TX G Mode 2462 MHz

Vertical

80 dBuV/m

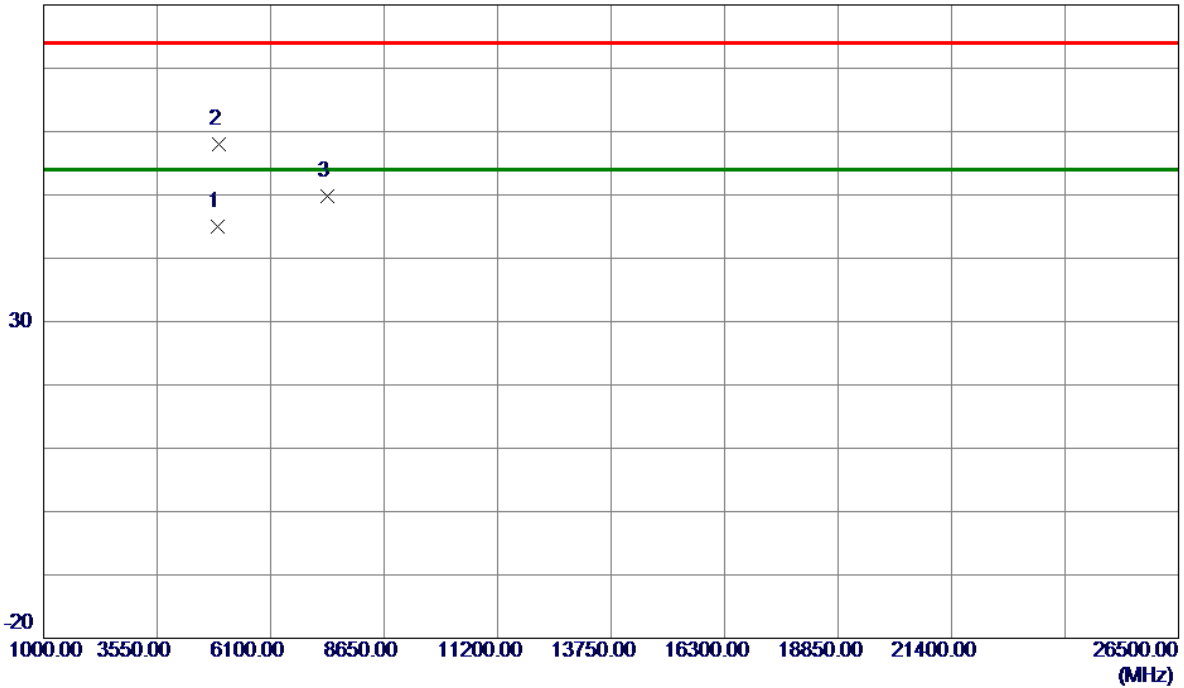

No.	Freq. MHz	Reading Level dBuV/m	Correct Factor dB	Measure ment dBuV/m	Limit dBuV/m	Margin dB	Detector	Comment
1 *	4922.6760	55.67	-10.63	45.04	54.00	-8.96	AVG	
2	4927.0000	68.62	-10.61	58.01	74.00	-15.99	Peak	
3	7385.2000	53.81	-3.98	49.83	74.00	-24.17	Peak	

REMARKS:

- (1) Measurement Value = Reading Level + Correct Factor.
- (2) Margin Level = Measurement Value - Limit Value.

Test Mode: TX G Mode 2462 MHz

Horizontal

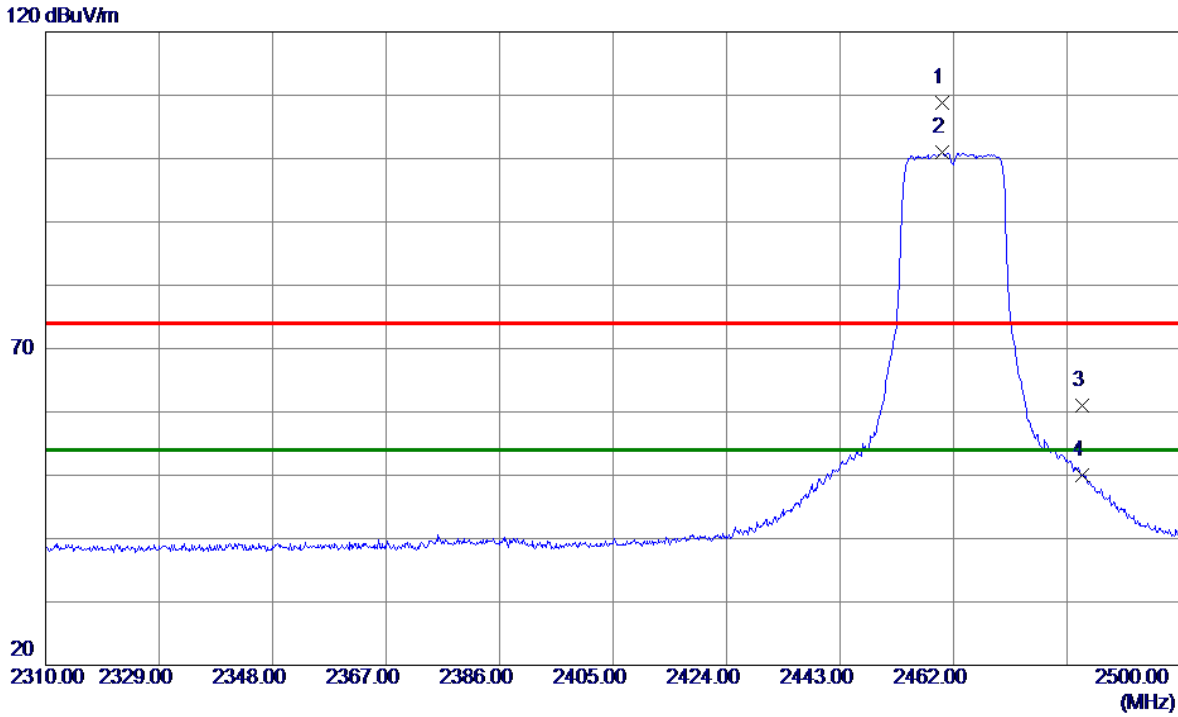

No.	Freq. MHz	Reading Level dBuV/m	Correct Factor dB	Measure ment dBuV/m	Limit dBuV/m	Margin dB	Detector	Comment
1	2460.1000	77.13	31.71	108.84	74.00	34.84	Peak	NO Limt
2 *	2460.1000	69.20	31.71	100.91	54.00	46.91	AVG	NO Limt
3	2483.5000	29.20	31.71	60.91	74.00	-13.09	Peak	
4	2483.5000	18.20	31.71	49.91	54.00	-4.09	AVG	

REMARKS:

- (1) Measurement Value = Reading Level + Correct Factor.
- (2) Margin Level = Measurement Value - Limit Value.

Test Mode: TX G Mode 2462 MHz

Horizontal

80 dBuV/m

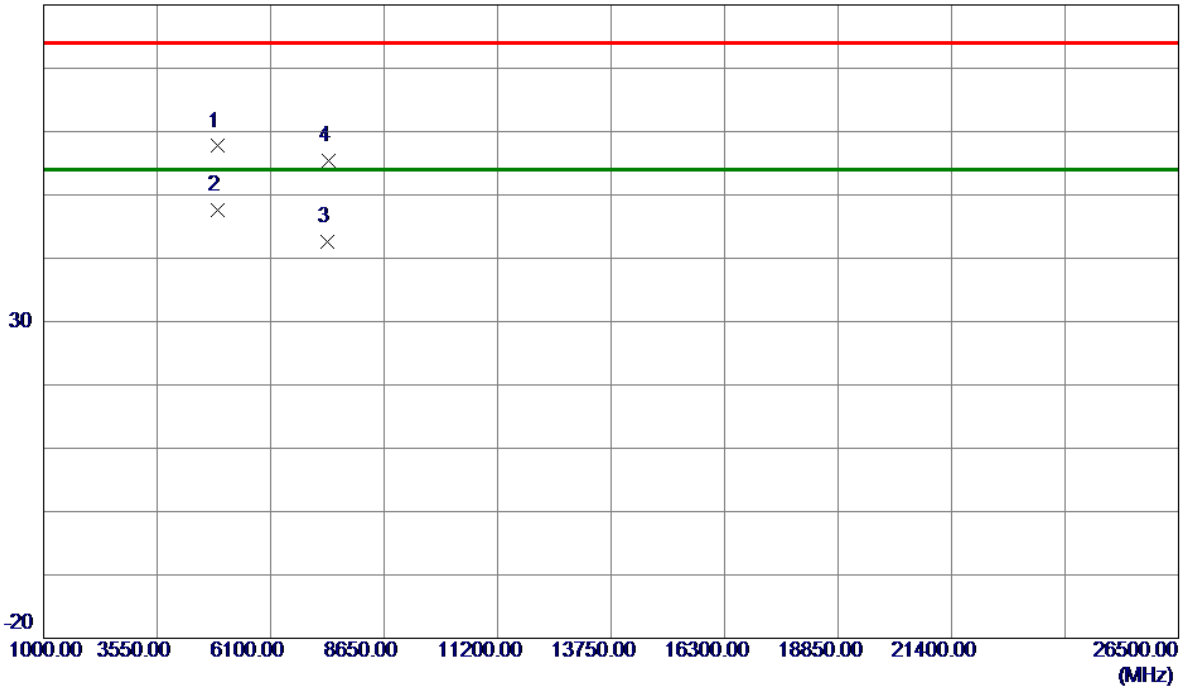

No.	Freq. MHz	Reading Level dBuV/m	Correct Factor dB	Measure ment dBuV/m	Limit dBuV/m	Margin dB	Detector	Comment
1	4921.9000	68.34	-10.64	57.70	74.00	-16.30	Peak	
2 *	4923.8760	58.29	-10.63	47.66	54.00	-6.34	AVG	
3	7381.2860	46.53	-3.98	42.55	54.00	-11.45	AVG	
4	7390.3000	59.32	-3.97	55.35	74.00	-18.65	Peak	

REMARKS:

- (1) Measurement Value = Reading Level + Correct Factor.
- (2) Margin Level = Measurement Value - Limit Value.

Test Mode: TX N-20M Mode 2412 MHz

Vertical

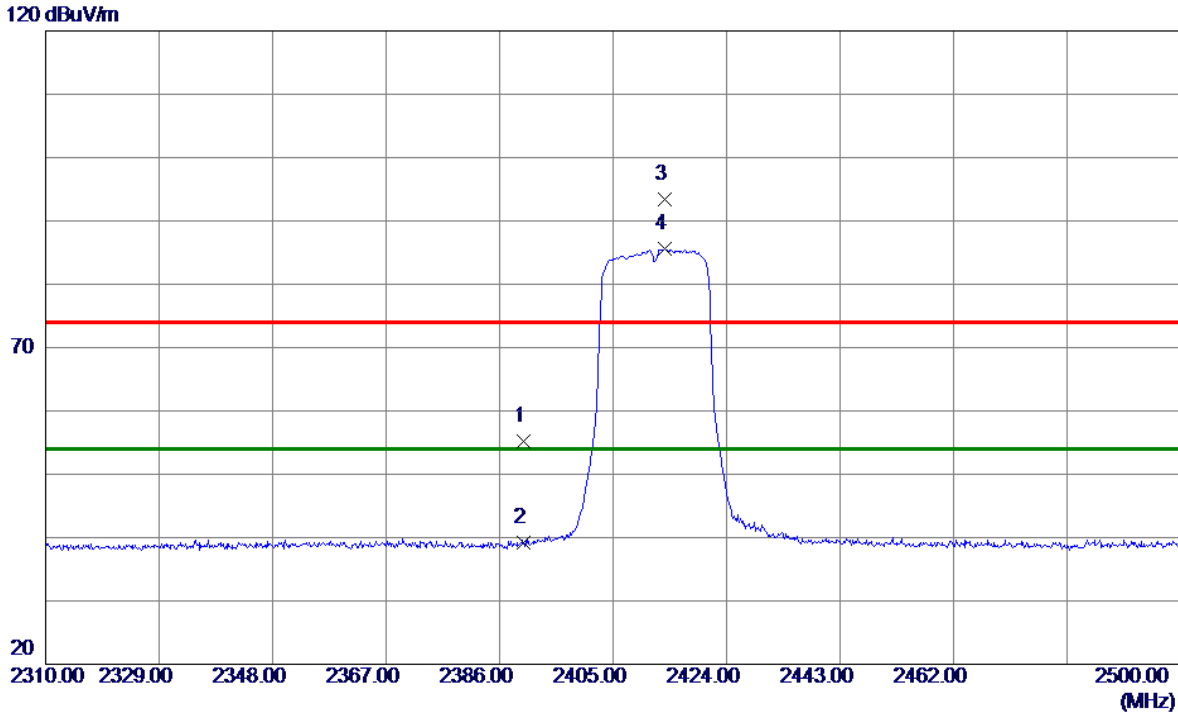

No.	Freq. MHz	Reading Level dBuV/m	Correct Factor dB	Measure ment dBuV/m	Limit dBuV/m	Margin dB	Detector	Comment
1	2390.0000	23.46	31.74	55.20	74.00	-18.80	Peak	
2	2390.0000	7.39	31.74	39.13	54.00	-14.87	AVG	
3	2413.6450	61.67	31.72	93.39	74.00	19.39	Peak	NO Limt
4 *	2413.6450	53.82	31.72	85.54	54.00	31.54	AVG	NO Limt

REMARKS:

- (1) Measurement Value = Reading Level + Correct Factor.
- (2) Margin Level = Measurement Value - Limit Value.

Test Mode: TX N-20M Mode 2412 MHz

Vertical

80 dBuV/m

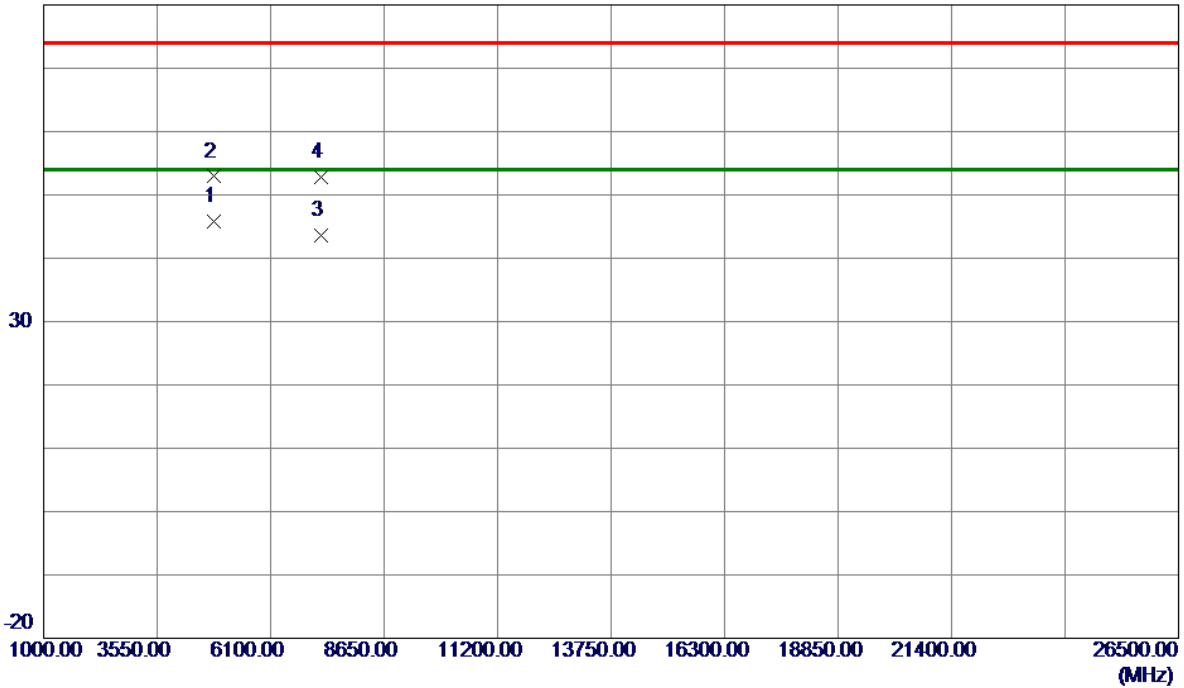

No.	Freq. MHz	Reading Level dBuV/m	Correct Factor dB	Measure ment dBuV/m	Limit dBuV/m	Margin dB	Detector	Comment
1 *	4823.8000	56.69	-10.91	45.78	54.00	-8.22	AVG	
2	4832.6500	63.79	-10.89	52.90	74.00	-21.10	Peak	
3	7239.3460	47.73	-4.17	43.56	54.00	-10.44	AVG	
4	7244.9500	56.93	-4.16	52.77	74.00	-21.23	Peak	

REMARKS:

- (1) Measurement Value = Reading Level + Correct Factor.
- (2) Margin Level = Measurement Value - Limit Value.

Test Mode: TX N-20M Mode 2412 MHz

Horizontal

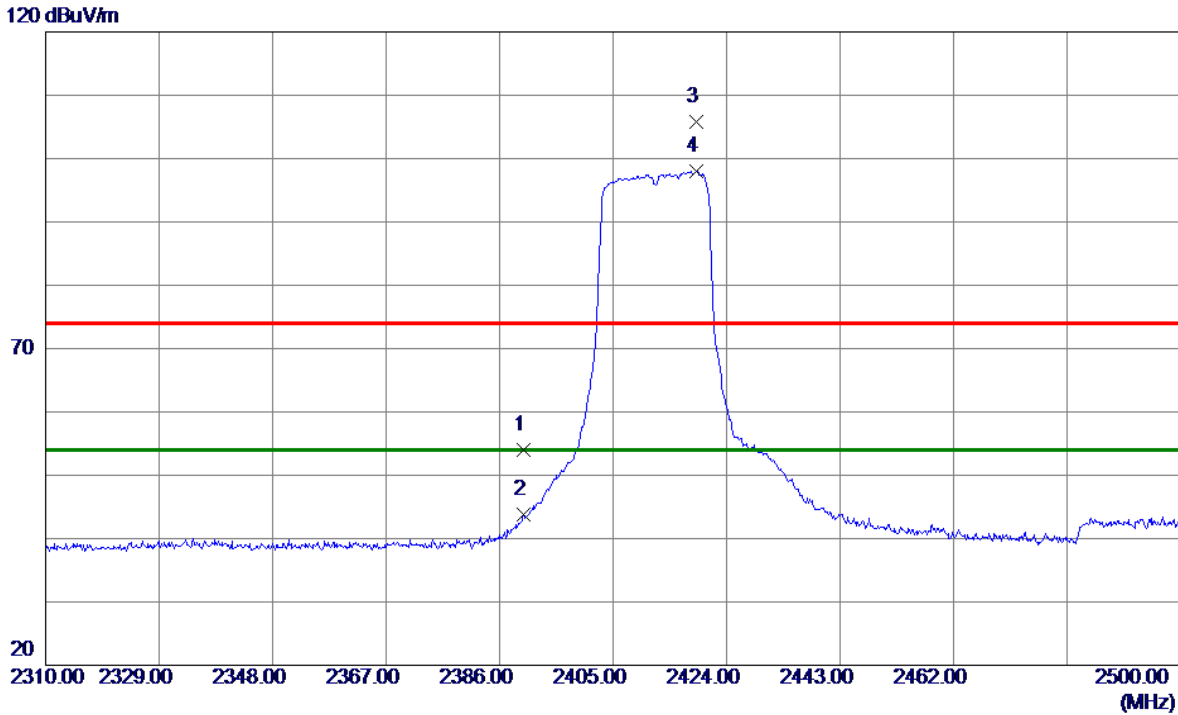

No.	Freq. MHz	Reading Level dBuV/m	Correct Factor dB	Measure ment dBuV/m	Limit dBuV/m	Margin dB	Detector	Comment
1	2390.0000	22.22	31.74	53.96	74.00	-20.04	Peak	
2	2390.0000	11.98	31.74	43.72	54.00	-10.28	AVG	
3	2418.8700	74.00	31.72	105.72	74.00	31.72	Peak	NO Limit
4 *	2418.8700	66.33	31.72	98.05	54.00	44.05	AVG	NO Limit

REMARKS:

- (1) Measurement Value = Reading Level + Correct Factor.
- (2) Margin Level = Measurement Value - Limit Value.

Test Mode: TX N-20M Mode 2412 MHz

Horizontal

80 dBuV/m

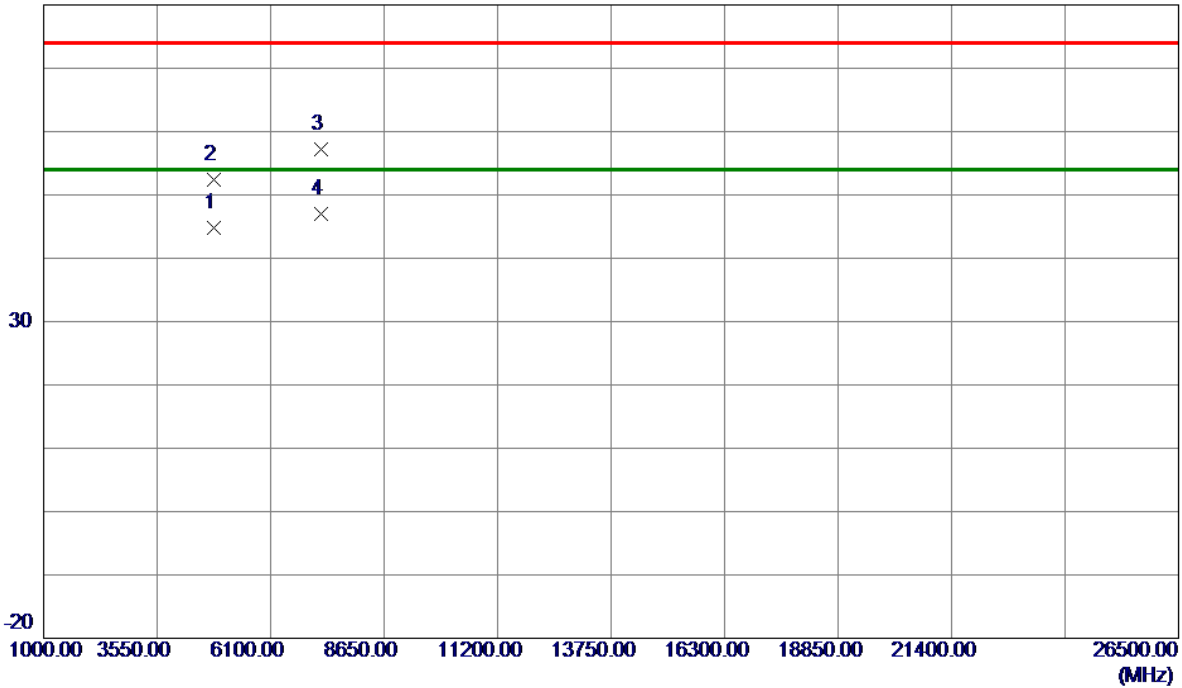

No.	Freq. MHz	Reading Level dBuV/m	Correct Factor dB	Measure ment dBuV/m	Limit dBuV/m	Margin dB	Detector	Comment
1	4824.4000	55.72	-10.91	44.81	54.00	-9.19	AVG	
2	4832.6500	63.25	-10.89	52.36	74.00	-21.64	Peak	
3	7229.6500	61.36	-4.18	57.18	74.00	-16.82	Peak	
4 *	7239.5340	51.15	-4.17	46.98	54.00	-7.02	AVG	

REMARKS:

- (1) Measurement Value = Reading Level + Correct Factor.
- (2) Margin Level = Measurement Value - Limit Value.

Test Mode: TX N-20M Mode 2437 MHz

Vertical

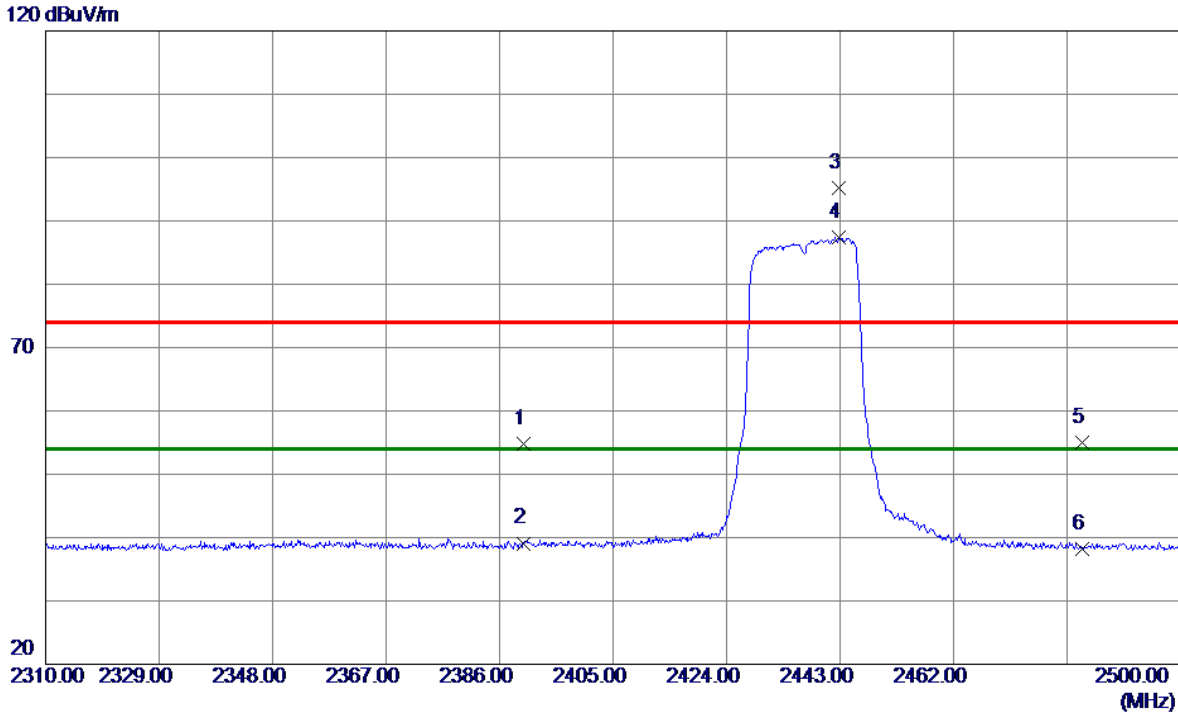

No.	Freq. MHz	Reading Level dBuV/m	Correct Factor dB	Measurement dBuV/m	Limit dBuV/m	Margin dB	Detector	Comment
1	2390.0000	22.99	31.74	54.73	74.00	-19.27	Peak	
2	2390.0000	7.36	31.74	39.10	54.00	-14.90	AVG	
3	2442.8100	63.53	31.72	95.25	74.00	21.25	Peak	NO Limit
4 *	2442.8100	55.63	31.72	87.35	54.00	33.35	AVG	NO Limit
5	2483.5000	23.20	31.71	54.91	74.00	-19.09	Peak	
6	2483.5000	6.54	31.71	38.25	54.00	-15.75	AVG	

REMARKS:

- (1) Measurement Value = Reading Level + Correct Factor.
- (2) Margin Level = Measurement Value - Limit Value.

Test Mode: TX N-20M Mode 2437 MHz

Vertical

80 dBuV/m

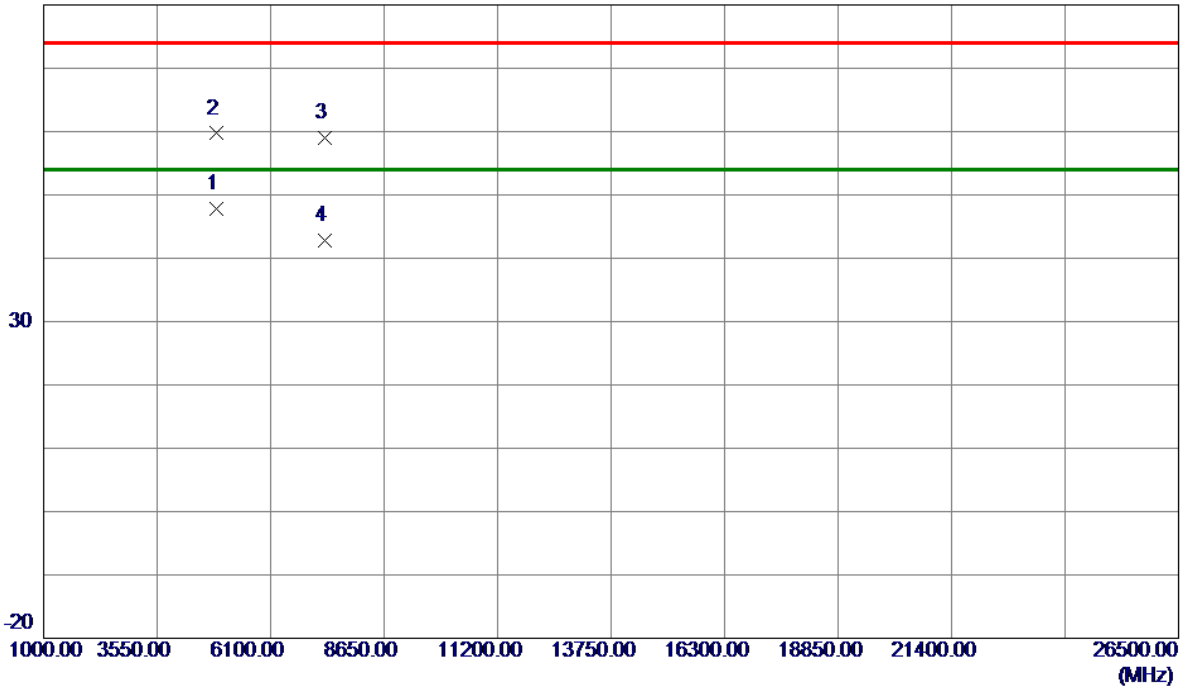

No.	Freq. MHz	Reading Level dBuV/m	Correct Factor dB	Measure ment dBuV/m	Limit dBuV/m	Margin dB	Detector	Comment
1 *	4873.7320	58.51	-10.79	47.72	54.00	-6.28	AVG	
2	4876.0000	70.49	-10.79	59.70	74.00	-14.30	Peak	
3	7308.7000	63.16	-4.08	59.08	74.00	-14.92	Peak	
4	7308.8460	46.87	-4.08	42.79	54.00	-11.21	AVG	

REMARKS:

- (1) Measurement Value = Reading Level + Correct Factor.
- (2) Margin Level = Measurement Value - Limit Value.

Test Mode: TX N-20M Mode 2437 MHz

Horizontal

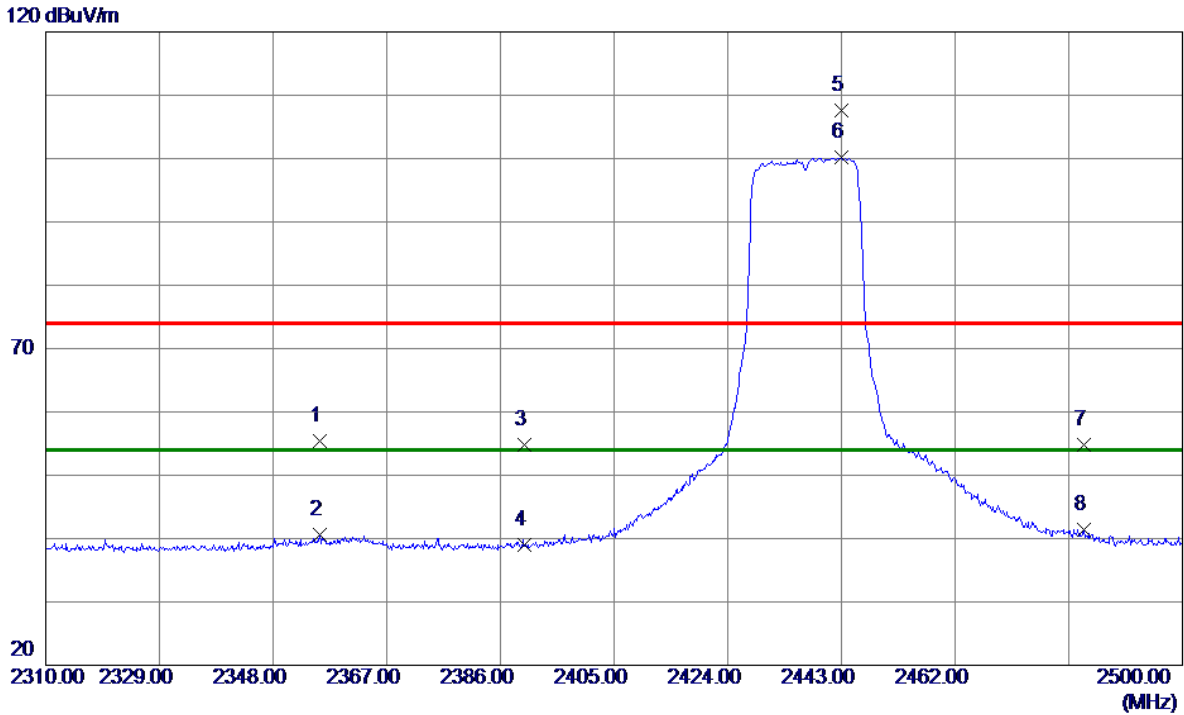

No.	Freq. MHz	Reading Level dBuV/m	Correct Factor dB	Measurement dBuV/m	Limit dBuV/m	Margin dB	Detector	Comment
1	2355.7900	23.60	31.81	55.41	74.00	-18.59	Peak	
2	2355.7900	8.74	31.81	40.55	54.00	-13.45	AVG	
3	2390.0000	22.98	31.74	54.72	74.00	-19.28	Peak	
4	2390.0000	7.27	31.74	39.01	54.00	-14.99	AVG	
5	2443.0950	75.93	31.72	107.65	74.00	33.65	Peak	NO Limit
6 *	2443.0950	68.47	31.72	100.19	54.00	46.19	AVG	NO Limit
7	2483.5000	23.07	31.71	54.78	74.00	-19.22	Peak	
8	2483.5000	9.66	31.71	41.37	54.00	-12.63	AVG	

REMARKS:

- (1) Measurement Value = Reading Level + Correct Factor.
- (2) Margin Level = Measurement Value - Limit Value.

Test Mode: TX N-20M Mode 2437 MHz

Horizontal

80 dBuV/m

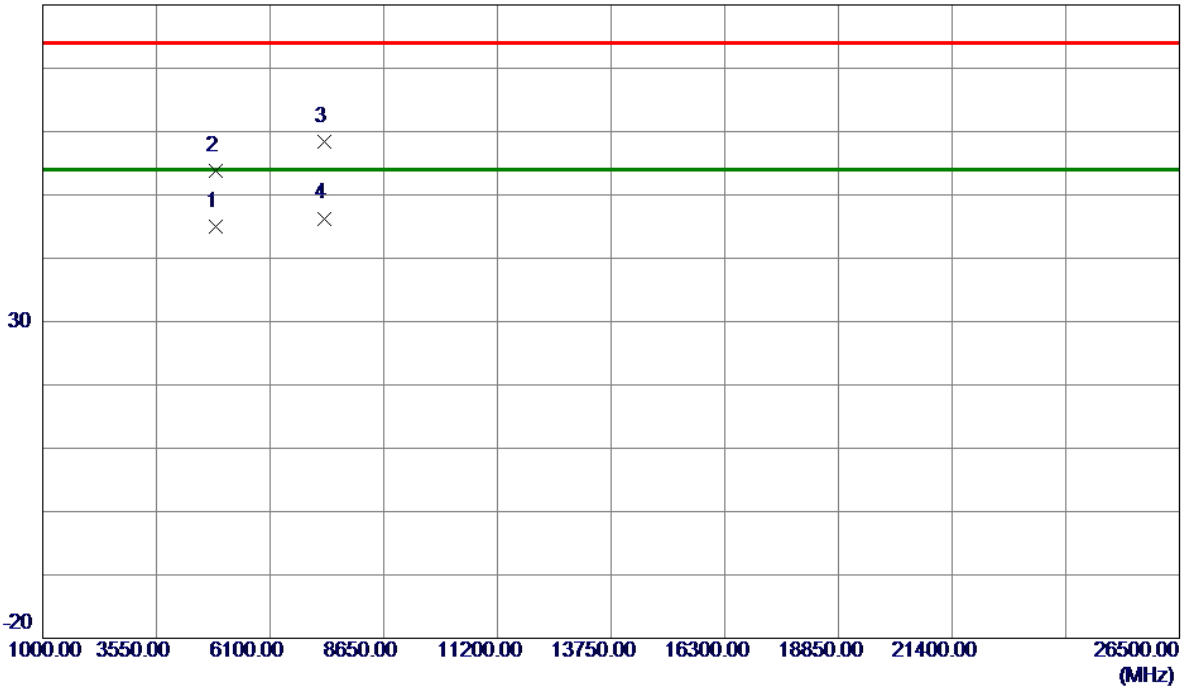

No.	Freq. MHz	Reading Level dBuV/m	Correct Factor dB	Measure ment dBuV/m	Limit dBuV/m	Margin dB	Detector	Comment
1	4874.7719	55.85	-10.79	45.06	54.00	-8.94	AVG	
2	4876.0000	64.68	-10.79	53.89	74.00	-20.11	Peak	
3	7306.1500	62.57	-4.08	58.49	74.00	-15.51	Peak	
4 *	7307.4760	50.38	-4.08	46.30	54.00	-7.70	AVG	

REMARKS:

- (1) Measurement Value = Reading Level + Correct Factor.
- (2) Margin Level = Measurement Value - Limit Value.

Test Mode: TX N-20M Mode 2462 MHz

Vertical

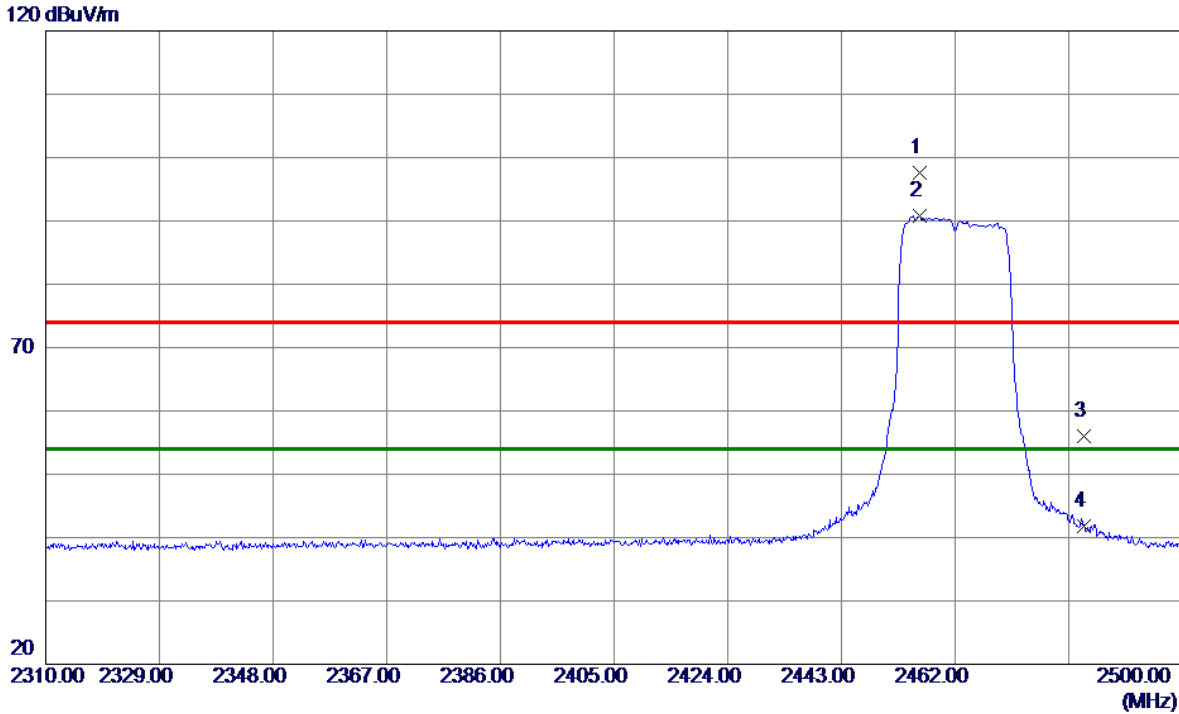

No.	Freq. MHz	Reading Level dBuV/m	Correct Factor dB	Measure ment dBuV/m	Limit dBuV/m	Margin dB	Detector	Comment
1	2456.0149	65.89	31.71	97.60	74.00	23.60	Peak	NO Limt
2 *	2456.0149	59.00	31.71	90.71	54.00	36.71	AVG	NO Limt
3	2483.5000	24.22	31.71	55.93	74.00	-18.07	Peak	
4	2483.5000	10.02	31.71	41.73	54.00	-12.27	AVG	

REMARKS:

- (1) Measurement Value = Reading Level + Correct Factor.
- (2) Margin Level = Measurement Value - Limit Value.

Test Mode: TX N-20M Mode 2462 MHz

Vertical

80 dBuV/m

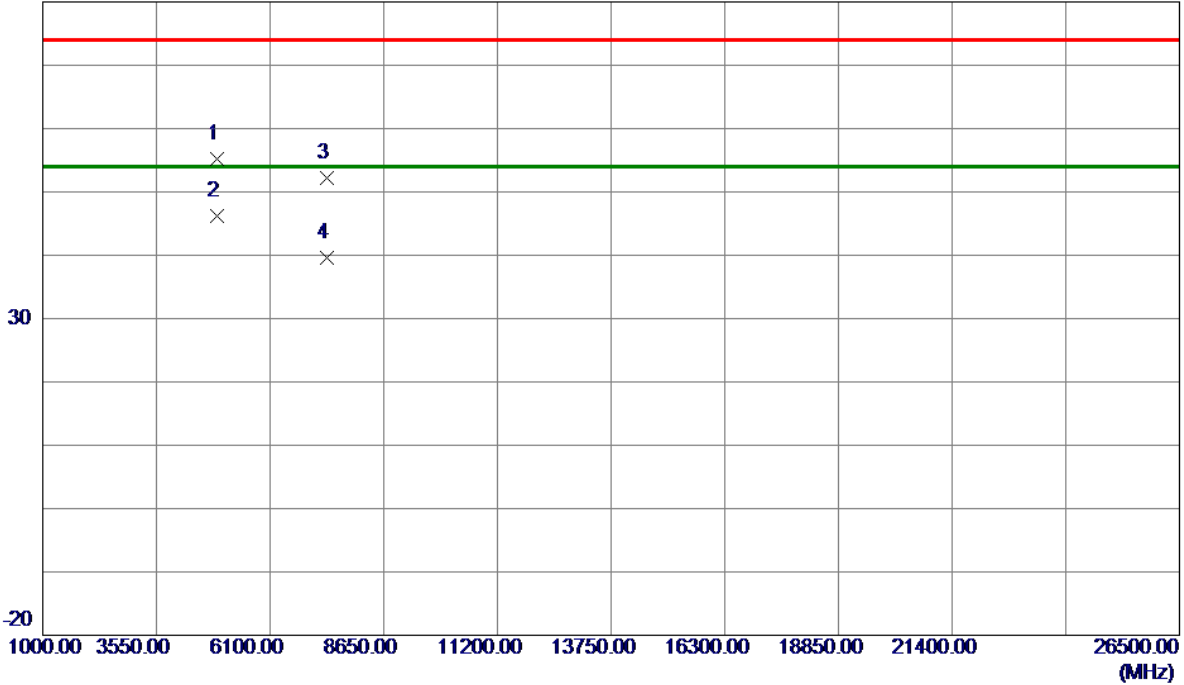

No.	Freq. MHz	Reading Level dBuV/m	Correct Factor dB	Measure ment dBuV/m	Limit dBuV/m	Margin dB	Detector	Comment
1	4919.3500	65.89	-10.65	55.24	74.00	-18.76	Peak	
2 *	4921.9600	56.87	-10.64	46.23	54.00	-7.77	AVG	
3	7380.1000	56.17	-3.99	52.18	74.00	-21.82	Peak	
4	7388.0140	43.64	-3.98	39.66	54.00	-14.34	AVG	

REMARKS:

- (1) Measurement Value = Reading Level + Correct Factor.
- (2) Margin Level = Measurement Value - Limit Value.

Test Mode: TX N-20M Mode 2462 MHz

Horizontal

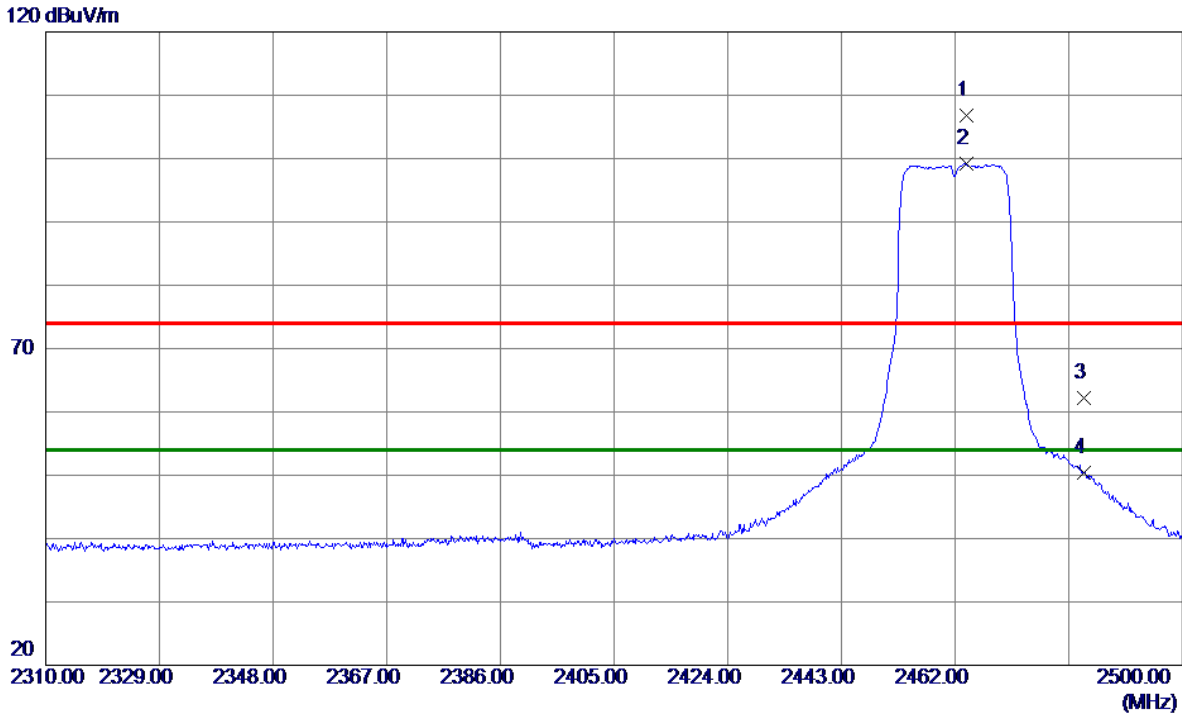

No.	Freq. MHz	Reading Level dBuV/m	Correct Factor dB	Measure ment dBuV/m	Limit dBuV/m	Margin dB	Detector	Comment
1	2463.8050	75.15	31.71	106.86	74.00	32.86	Peak	NO Limt
2 *	2463.8050	67.50	31.71	99.21	54.00	45.21	AVG	NO Limt
3	2483.5000	30.56	31.71	62.27	74.00	-11.73	Peak	
4	2483.5000	18.71	31.71	50.42	54.00	-3.58	AVG	

REMARKS:

- (1) Measurement Value = Reading Level + Correct Factor.
- (2) Margin Level = Measurement Value - Limit Value.

Test Mode: TX N-20M Mode 2462 MHz

Horizontal

80 dBuV/m

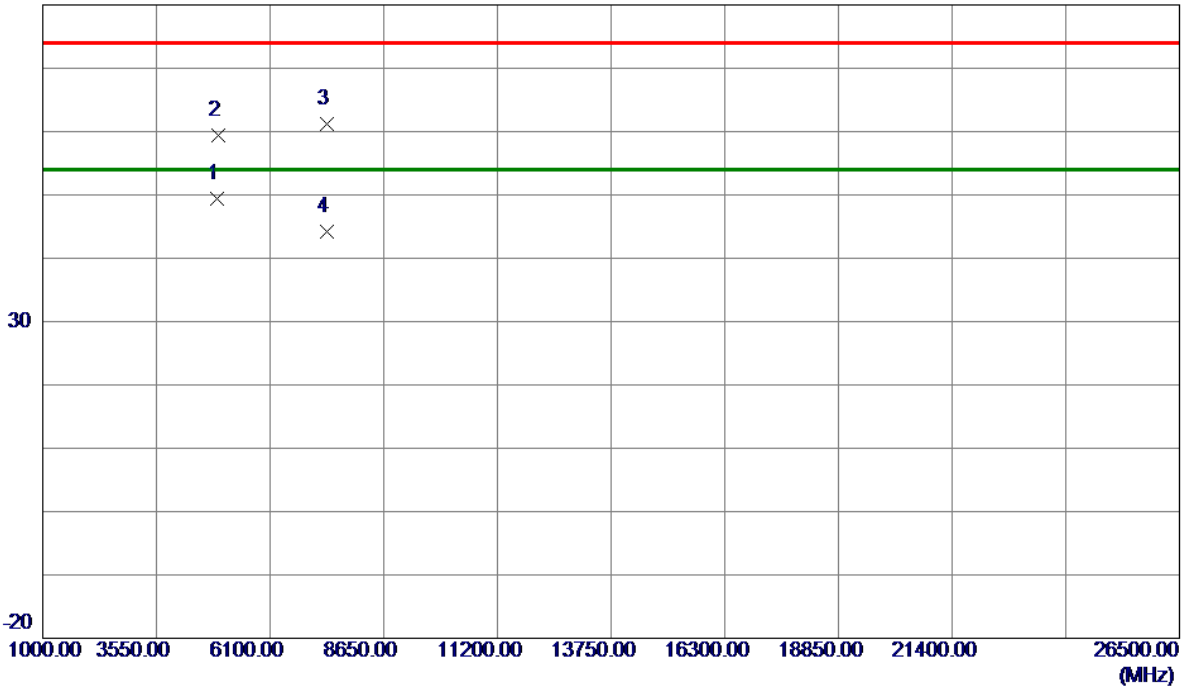

No.	Freq. MHz	Reading Level dBuV/m	Correct Factor dB	Measure ment dBuV/m	Limit dBuV/m	Margin dB	Detector	Comment
1 *	4922.6380	60.12	-10.63	49.49	54.00	-4.51	AVG	
2	4927.0000	70.00	-10.61	59.39	74.00	-14.61	Peak	
3	7382.6500	65.15	-3.98	61.17	74.00	-12.83	Peak	
4	7382.9080	48.25	-3.98	44.27	54.00	-9.73	AVG	

REMARKS:

- (1) Measurement Value = Reading Level + Correct Factor.
- (2) Margin Level = Measurement Value - Limit Value.

Test Mode: TX N-40M Mode 2422MHz

Vertical

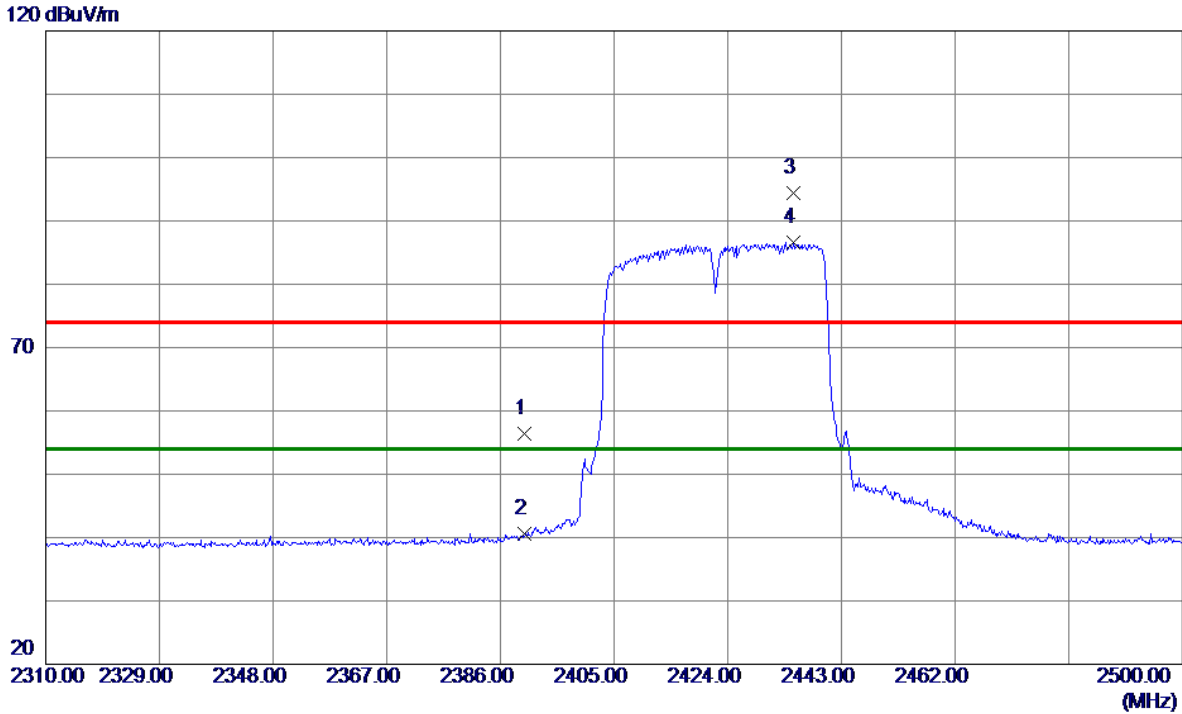

No.	Freq. MHz	Reading Level dBuV/m	Correct Factor dB	Measure ment dBuV/m	Limit dBuV/m	Margin dB	Detector	Comment
1	2390.0000	24.74	31.74	56.48	74.00	-17.52	Peak	
2	2390.0000	8.79	31.74	40.53	54.00	-13.47	AVG	
3	2435.0200	62.67	31.72	94.39	74.00	20.39	Peak	NO Limt
4 *	2435.0200	54.81	31.72	86.53	54.00	32.53	AVG	NO Limt

REMARKS:

- (1) Measurement Value = Reading Level + Correct Factor.
- (2) Margin Level = Measurement Value - Limit Value.

Test Mode: TX N-40M Mode 2422MHz

Vertical

80 dBuV/m

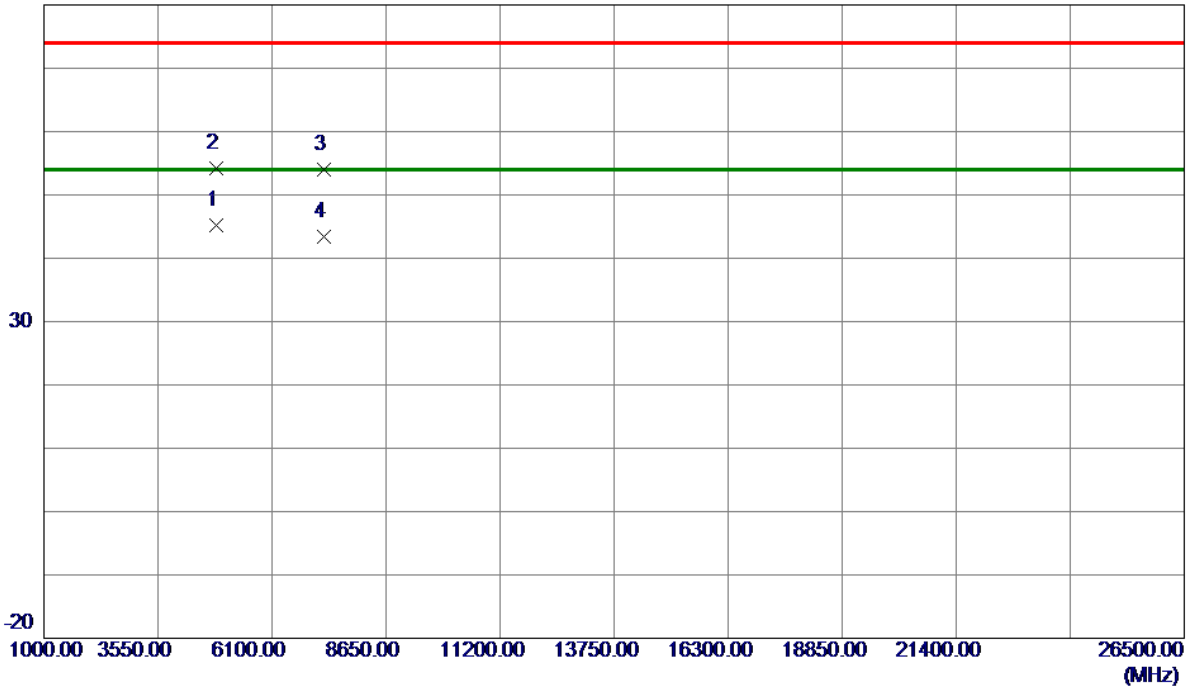

No.	Freq. MHz	Reading Level dBuV/m	Correct Factor dB	Measure ment dBuV/m	Limit dBuV/m	Margin dB	Detector	Comment
1 *	4844.6360	55.98	-10.86	45.12	54.00	-8.88	AVG	
2	4850.5000	65.14	-10.85	54.29	74.00	-19.71	Peak	
3	7252.6000	58.11	-4.15	53.96	74.00	-20.04	Peak	
4	7265.5960	47.44	-4.13	43.31	54.00	-10.69	AVG	

REMARKS:

- (1) Measurement Value = Reading Level + Correct Factor.
- (2) Margin Level = Measurement Value - Limit Value.

Test Mode: TX N-40M Mode 2422MHz

Horizontal

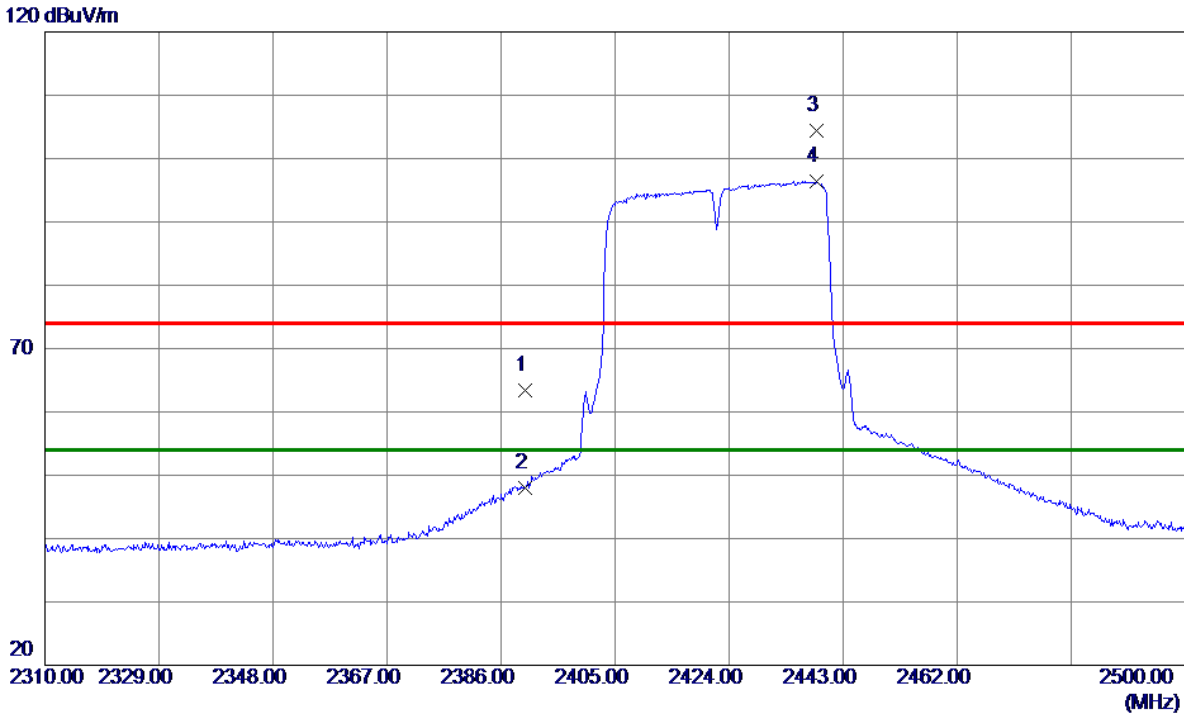

No.	Freq. MHz	Reading Level dBuV/m	Correct Factor dB	Measure ment dBuV/m	Limit dBuV/m	Margin dB	Detector	Comment
1	2390.0000	31.62	31.74	63.36	74.00	-10.64	Peak	
2	2390.0000	16.33	31.74	48.07	54.00	-5.93	AVG	
3	2438.6299	72.76	31.72	104.48	74.00	30.48	Peak	NO Limt
4 *	2438.6299	64.69	31.72	96.41	54.00	42.41	AVG	NO Limt

REMARKS:

- (1) Measurement Value = Reading Level + Correct Factor.
- (2) Margin Level = Measurement Value - Limit Value.

Test Mode: TX N-40M Mode 2422MHz

Horizontal

80 dBuV/m

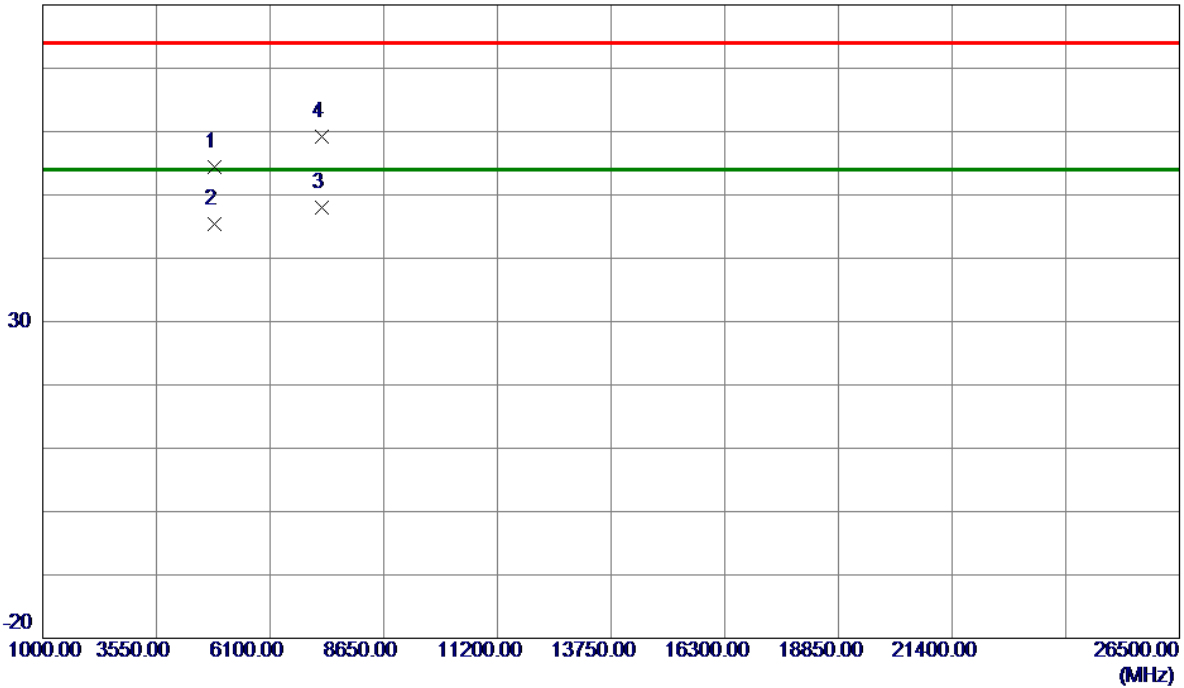

No.	Freq. MHz	Reading Level dBuV/m	Correct Factor dB	Measure ment dBuV/m	Limit dBuV/m	Margin dB	Detector	Comment
1	4842.8500	65.21	-10.86	54.35	74.00	-19.65	Peak	
2	4843.8340	56.22	-10.86	45.36	54.00	-8.64	AVG	
3 *	7262.9500	52.05	-4.14	47.91	54.00	-6.09	AVG	
4	7270.4500	63.34	-4.13	59.21	74.00	-14.79	Peak	

REMARKS:

- (1) Measurement Value = Reading Level + Correct Factor.
- (2) Margin Level = Measurement Value - Limit Value.

Test Mode: TX N-40M Mode 2437 MHz

Vertical

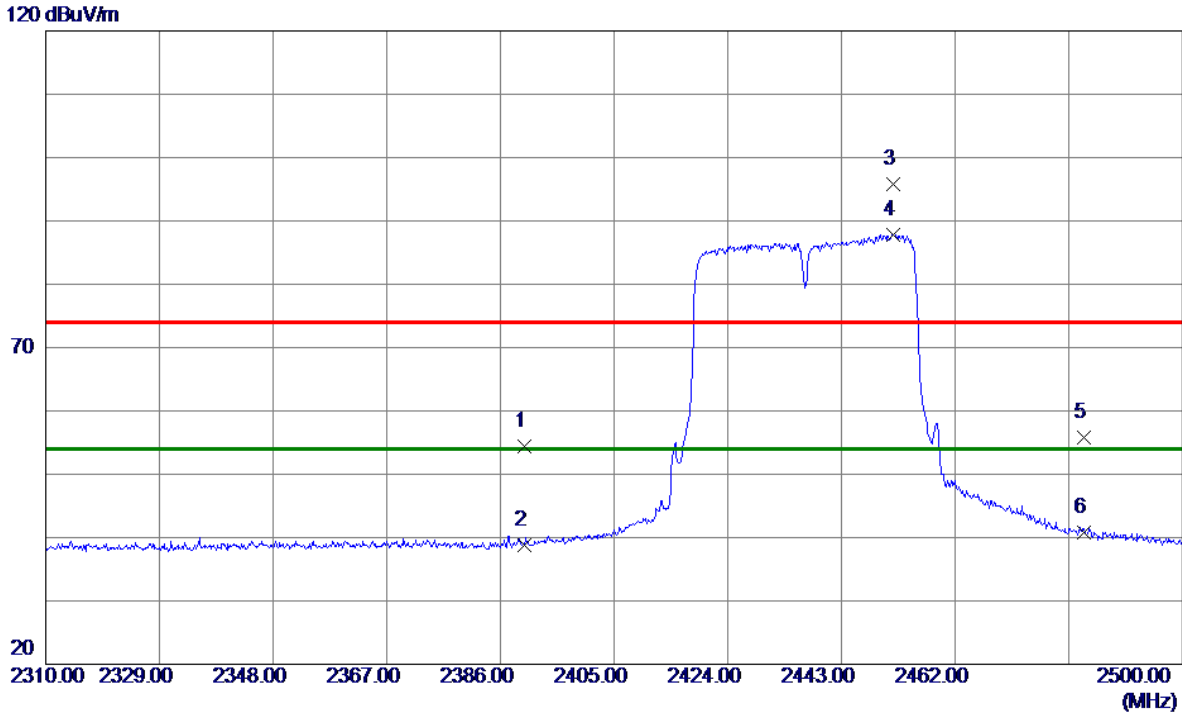

No.	Freq. MHz	Reading Level dBuV/m	Correct Factor dB	Measure ment dBuV/m	Limit dBuV/m	Margin dB	Detector	Comment
1	2390.0000	22.66	31.74	54.40	74.00	-19.60	Peak	
2	2390.0000	7.08	31.74	38.82	54.00	-15.18	AVG	
3	2451.5500	64.06	31.71	95.77	74.00	21.77	Peak	NO Limit
4 *	2451.5500	56.07	31.71	87.78	54.00	33.78	AVG	NO Limit
5	2483.5000	24.01	31.71	55.72	74.00	-18.28	Peak	
6	2483.5000	9.16	31.71	40.87	54.00	-13.13	AVG	

REMARKS:

- (1) Measurement Value = Reading Level + Correct Factor.
- (2) Margin Level = Measurement Value - Limit Value.

Test Mode: TX N-40M Mode 2437 MHz

Vertical

80 dBuV/m

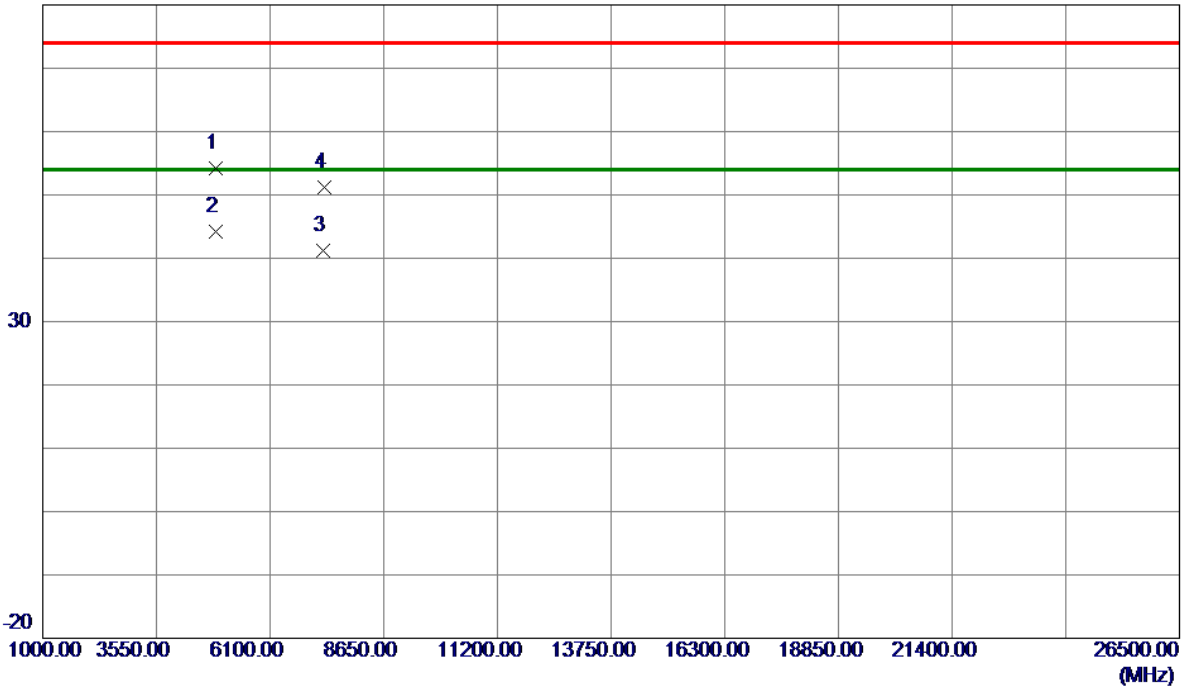

No.	Freq. MHz	Reading Level dBuV/m	Correct Factor dB	Measure ment dBuV/m	Limit dBuV/m	Margin dB	Detector	Comment
1	4870.9000	65.07	-10.80	54.27	74.00	-19.73	Peak	
2 *	4874.5960	55.06	-10.79	44.27	54.00	-9.73	AVG	
3	7296.9480	45.28	-4.09	41.19	54.00	-12.81	AVG	
4	7308.7000	55.27	-4.08	51.19	74.00	-22.81	Peak	

REMARKS:

- (1) Measurement Value = Reading Level + Correct Factor.
- (2) Margin Level = Measurement Value - Limit Value.

Test Mode: TX N-40M Mode 2437 MHz

Horizontal

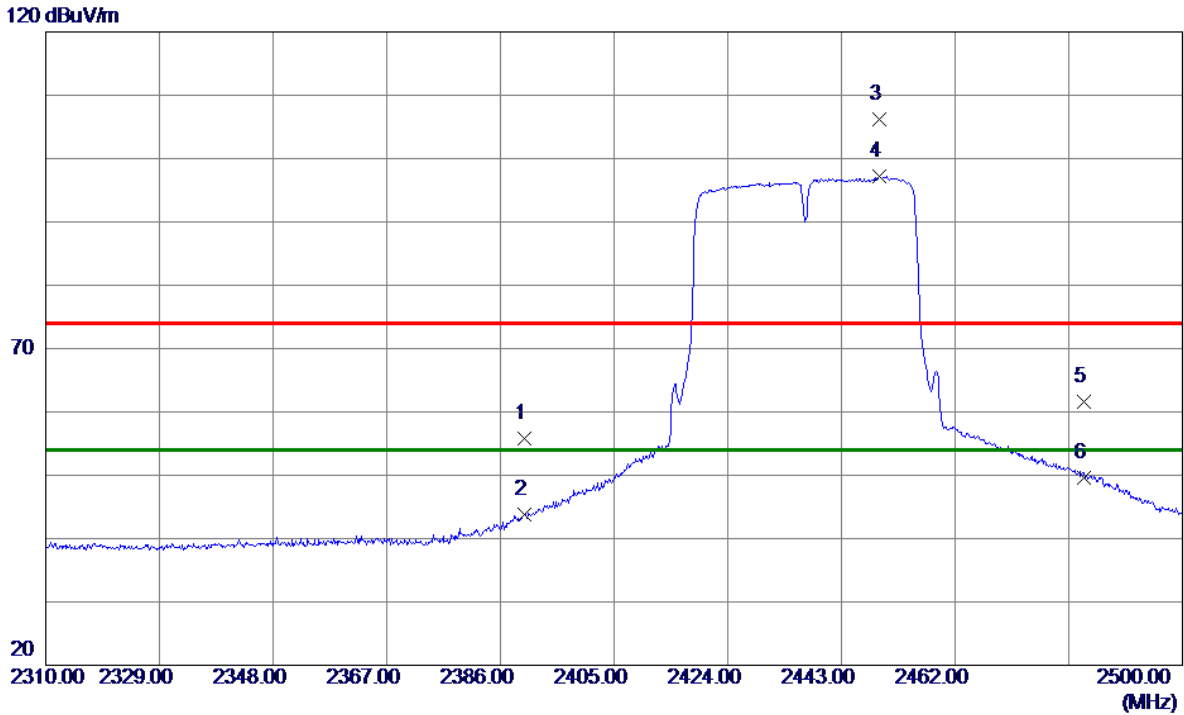

No.	Freq. MHz	Reading Level dBuV/m	Correct Factor dB	Measure ment dBuV/m	Limit dBuV/m	Margin dB	Detector	Comment
1	2390.0000	24.08	31.74	55.82	74.00	-18.18	Peak	
2	2390.0000	11.97	31.74	43.71	54.00	-10.29	AVG	
3	2449.3650	74.52	31.72	106.24	74.00	32.24	Peak	NO Limit
4 *	2449.3650	65.43	31.72	97.15	54.00	43.15	AVG	NO Limit
5	2483.5000	29.82	31.71	61.53	74.00	-12.47	Peak	
6	2483.5000	17.90	31.71	49.61	54.00	-4.39	AVG	

REMARKS:

(1) Measurement Value = Reading Level + Correct Factor.

(2) Margin Level = Measurement Value - Limit Value.

Test Mode: TX N-40M Mode 2437 MHz

Horizontal

80 dBuV/m

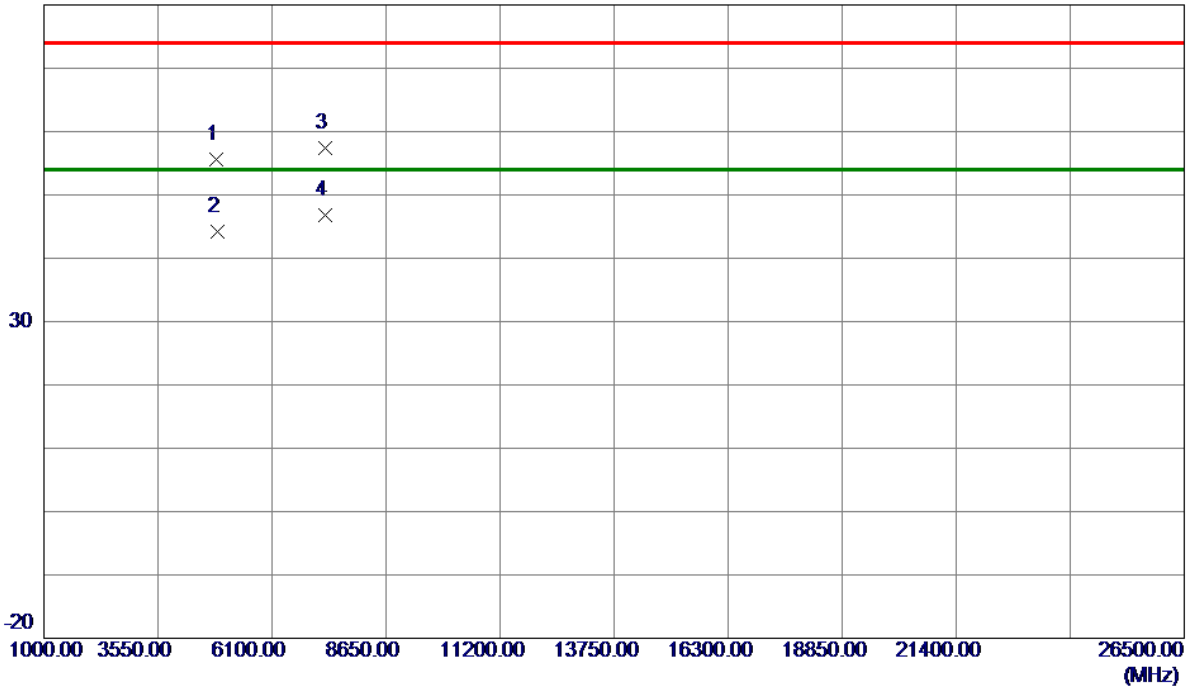

No.	Freq. MHz	Reading Level dBuV/m	Correct Factor dB	Measure ment dBuV/m	Limit dBuV/m	Margin dB	Detector	Comment
1	4865.8000	66.47	-10.81	55.66	74.00	-18.34	Peak	
2	4874.3280	55.05	-10.79	44.26	54.00	-9.74	AVG	
3	7298.5000	61.51	-4.09	57.42	74.00	-16.58	Peak	
4 *	7301.9120	50.88	-4.09	46.79	54.00	-7.21	AVG	

REMARKS:

- (1) Measurement Value = Reading Level + Correct Factor.
- (2) Margin Level = Measurement Value - Limit Value.

Test Mode: TX N-40M Mode 2452 MHz

Vertical

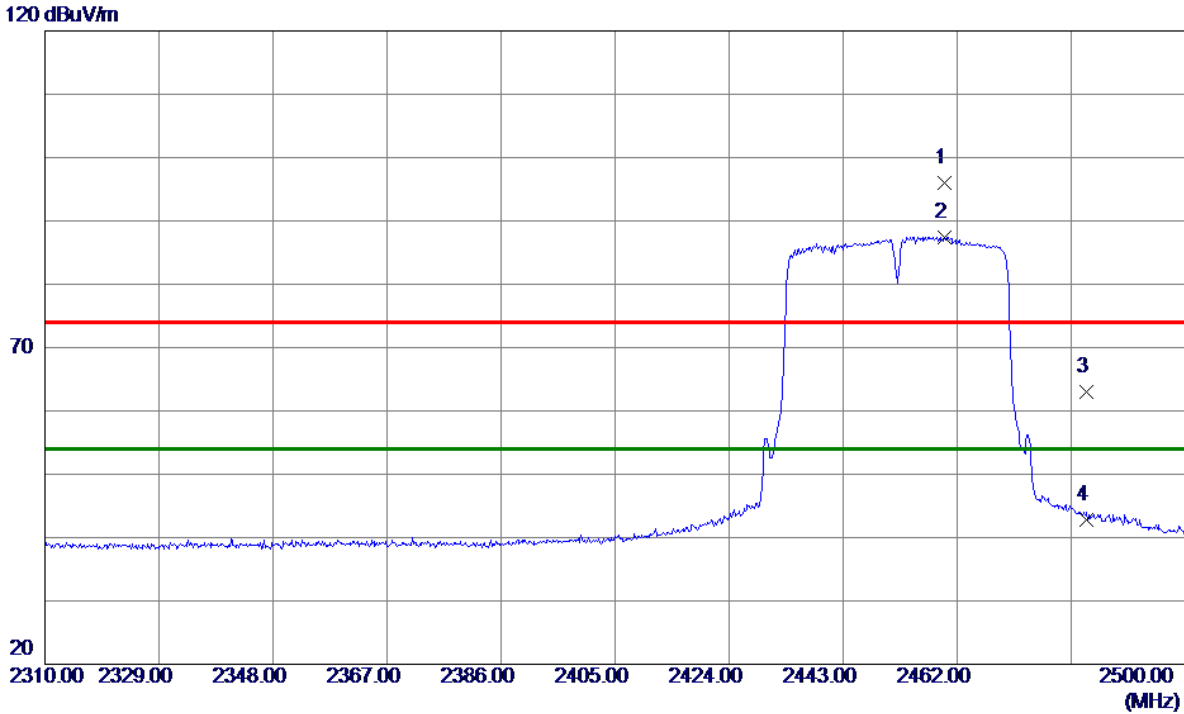

No.	Freq. MHz	Reading Level dBuV/m	Correct Factor dB	Measure ment dBuV/m	Limit dBuV/m	Margin dB	Detector	Comment
1	2459.8150	64.27	31.71	95.98	74.00	21.98	Peak	NO Limt
2 *	2459.8150	55.78	31.71	87.49	54.00	33.49	AVG	NO Limt
3	2483.5000	31.20	31.71	62.91	74.00	-11.09	Peak	
4	2483.5000	11.09	31.71	42.80	54.00	-11.20	AVG	

REMARKS:

- (1) Measurement Value = Reading Level + Correct Factor.
- (2) Margin Level = Measurement Value - Limit Value.

Test Mode: TX N-40M Mode 2452 MHz

Vertical

80 dBuV/m

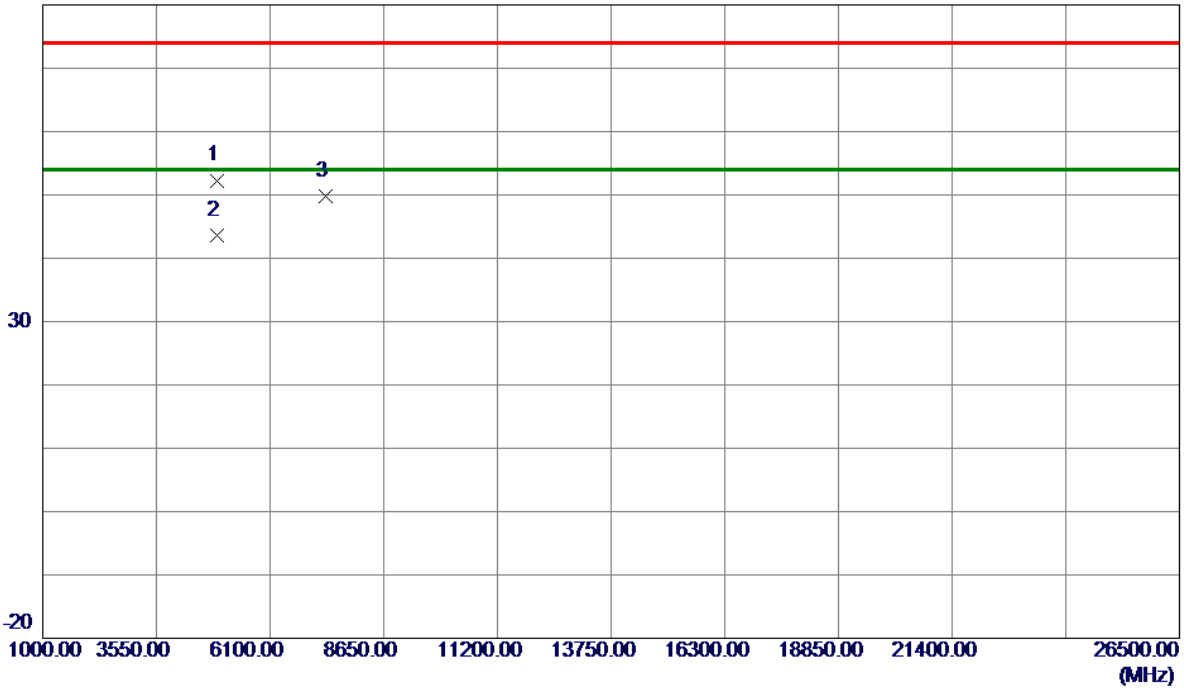

No.	Freq. MHz	Reading Level dBuV/m	Correct Factor dB	Measure ment dBuV/m	Limit dBuV/m	Margin dB	Detector	Comment
1	4901.5000	63.03	-10.73	52.30	74.00	-21.70	Peak	
2 *	4904.3440	54.26	-10.72	43.54	54.00	-10.46	AVG	
3	7339.3000	53.78	-4.04	49.74	74.00	-24.26	Peak	

REMARKS:

- (1) Measurement Value = Reading Level + Correct Factor.
- (2) Margin Level = Measurement Value - Limit Value.

Test Mode: TX N-40M Mode 2452 MHz

Horizontal

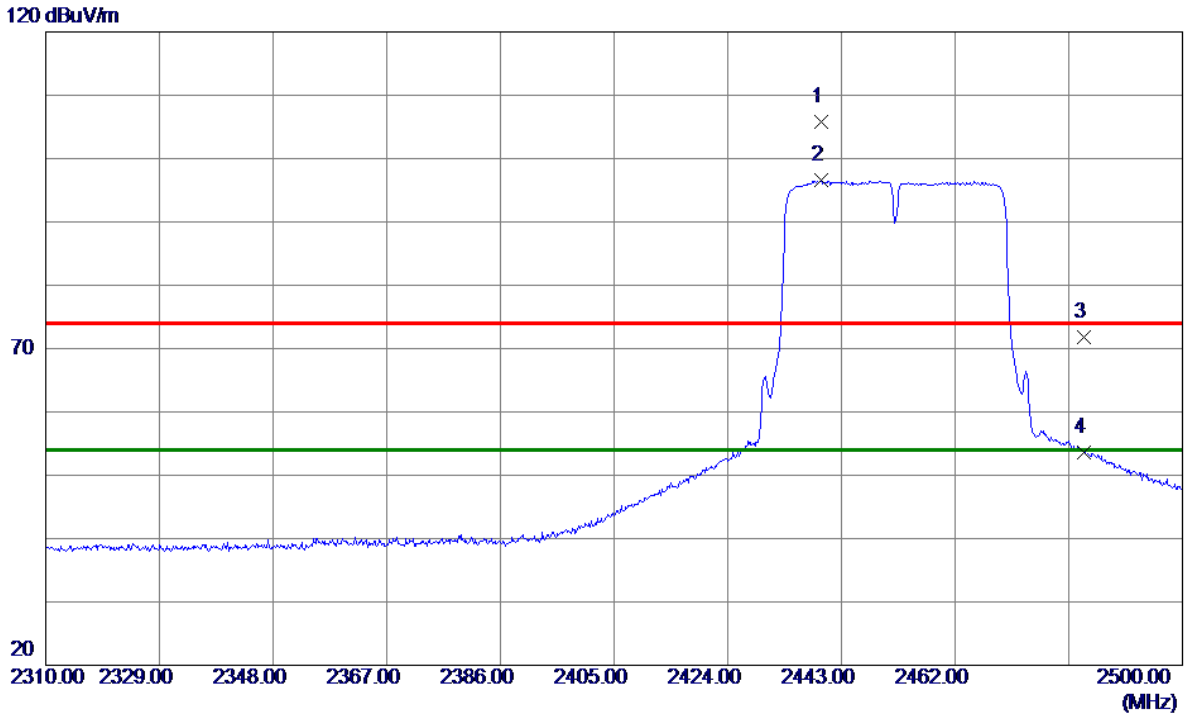

No.	Freq. MHz	Reading Level dBuV/m	Correct Factor dB	Measure ment dBuV/m	Limit dBuV/m	Margin dB	Detector	Comment
1	2439.5800	74.00	31.72	105.72	74.00	31.72	Peak	NO Limit
2 *	2439.5800	64.81	31.72	96.53	54.00	42.53	AVG	NO Limit
3	2483.5000	40.01	31.71	71.72	74.00	-2.28	Peak	
4	2483.5000	21.94	31.71	53.65	54.00	-0.35	AVG	

REMARKS:

- (1) Measurement Value = Reading Level + Correct Factor.
- (2) Margin Level = Measurement Value - Limit Value.

Test Mode: TX N-40M Mode 2452 MHz

Horizontal

80 dBuV/m

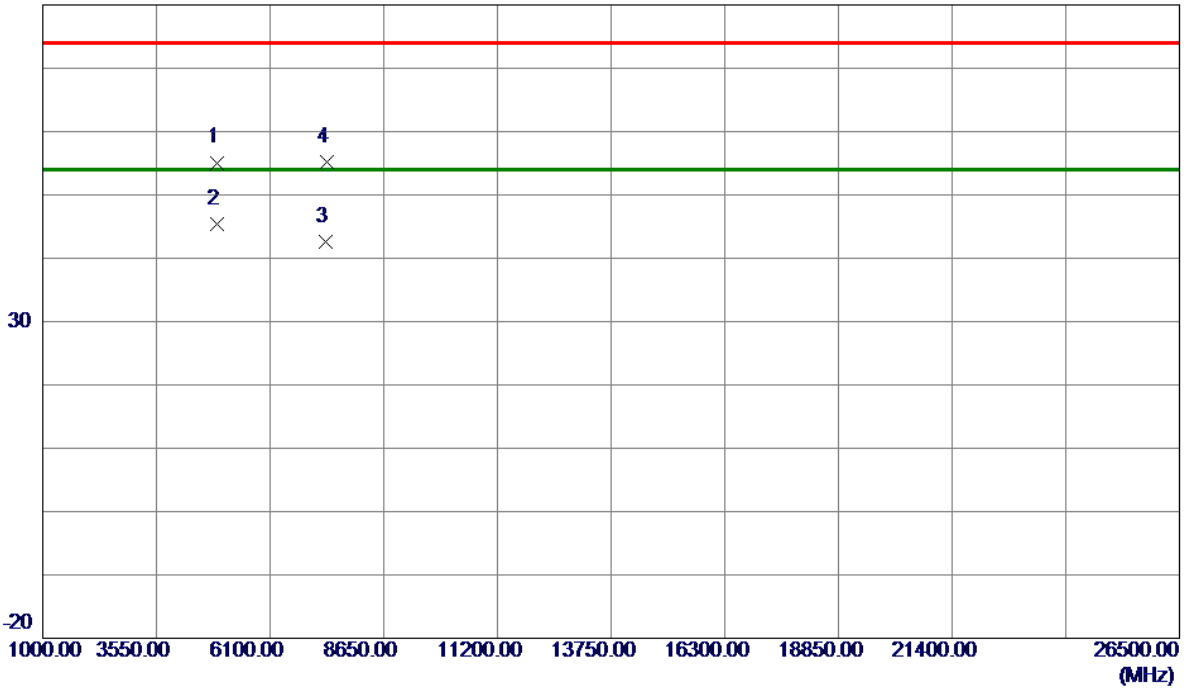

No.	Freq. MHz	Reading Level dBuV/m	Correct Factor dB	Measure ment dBuV/m	Limit dBuV/m	Margin dB	Detector	Comment
1	4906.6000	65.80	-10.70	55.10	74.00	-18.90	Peak	
2 *	4912.0600	55.99	-10.68	45.31	54.00	-8.69	AVG	
3	7355.9580	46.61	-4.02	42.59	54.00	-11.41	AVG	
4	7367.3500	59.15	-4.00	55.15	74.00	-18.85	Peak	

REMARKS:

- (1) Measurement Value = Reading Level + Correct Factor.
- (2) Margin Level = Measurement Value - Limit Value.

APPENDIX E - BANDWIDTH

Test Mode	TX B Mode
-----------	-----------

Channel	Frequency (MHz)	6 dB Bandwidth (MHz)	6 dB Bandwidth Min. Limit (kHz)	Result
01	2412	8.58	500	Complies
06	2437	8.12	500	Complies
11	2462	9.10	500	Complies

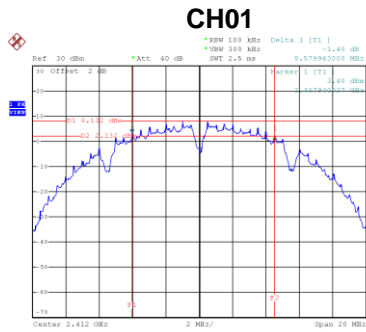

Date: 11.AUG.2020 12:20:46

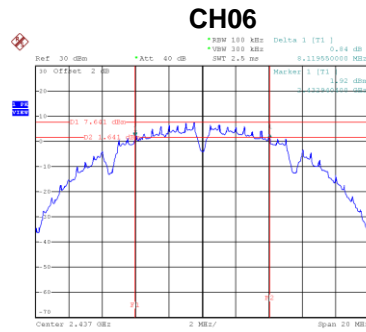

Date: 11.AUG.2020 12:21:55

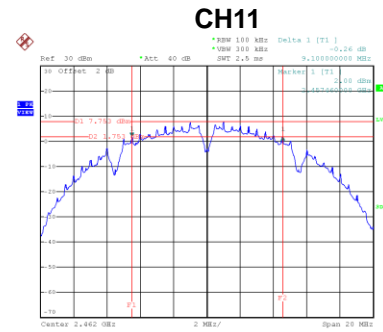

Date: 11.AUG.2020 12:23:43

Channel	Frequency (MHz)	99 % Emission Bandwidth (MHz)	Result
01	2412	13.52	Complies
06	2437	13.52	Complies
11	2462	13.52	Complies

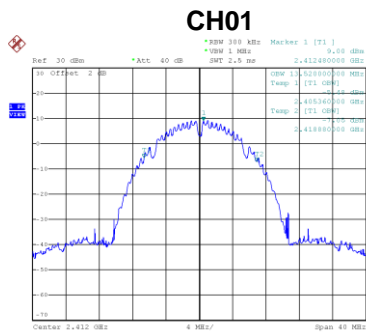

Date: 11.AUG.2020 12:20:53

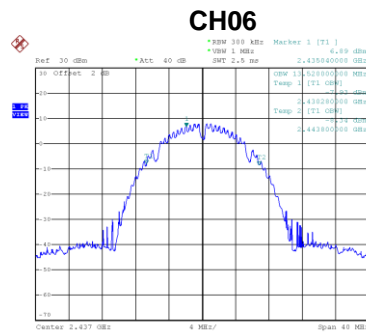

Date: 11.AUG.2020 12:22:02

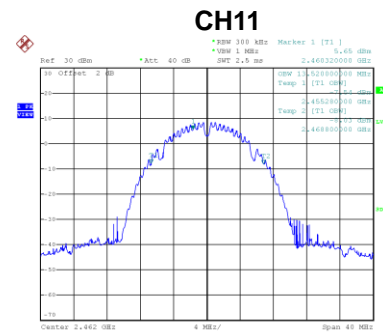

Date: 11.AUG.2020 12:23:50

Test Mode	TX G Mode
-----------	-----------

Channel	Frequency (MHz)	6 dB Bandwidth (MHz)	6 dB Bandwidth Min. Limit (kHz)	Result
01	2412	16.42	500	Complies
06	2437	16.46	500	Complies
11	2462	16.45	500	Complies

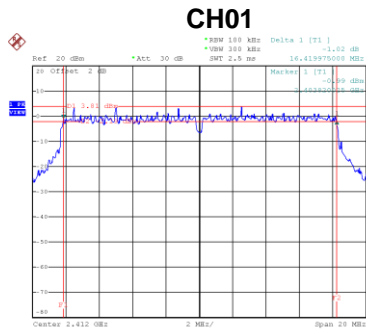

Date: 11.AUG.2020 12:25:56

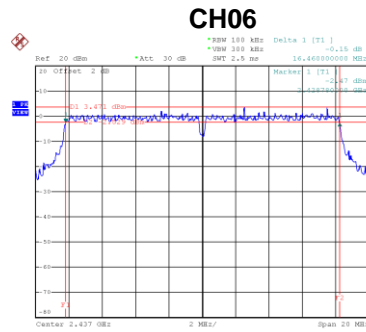

Date: 11.AUG.2020 12:31:15

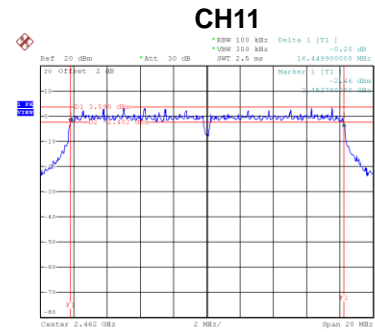

Date: 11.AUG.2020 12:28:56

Channel	Frequency (MHz)	99 % Emission Bandwidth (MHz)	Result
01	2412	17.04	Complies
06	2437	16.88	Complies
11	2462	16.96	Complies

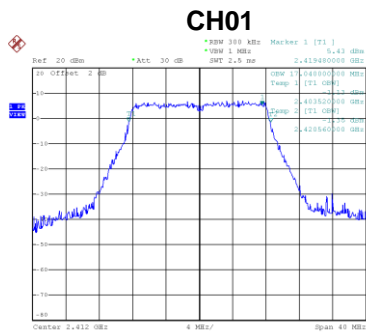

Date: 11.AUG.2020 12:26:03

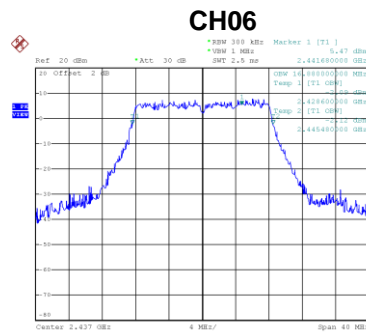

Date: 11.AUG.2020 12:31:21

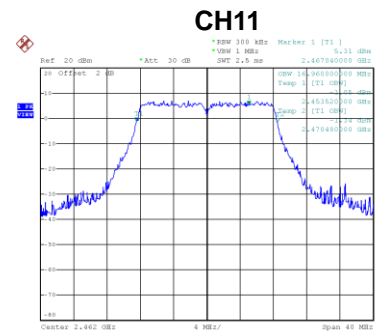

Date: 11.AUG.2020 12:29:02

Test Mode	TX N-20M Mode
-----------	---------------

Channel	Frequency (MHz)	6 dB Bandwidth (MHz)	6 dB Bandwidth Min. Limit (kHz)	Result
01	2412	17.58	500	Complies
06	2437	17.62	500	Complies
11	2462	17.63	500	Complies

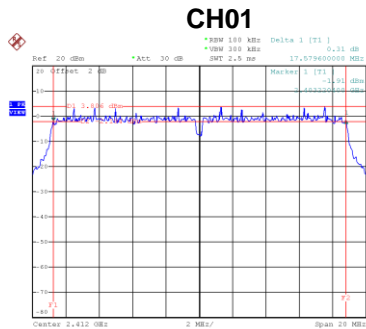

Date: 11.AUG.2020 12:13:10

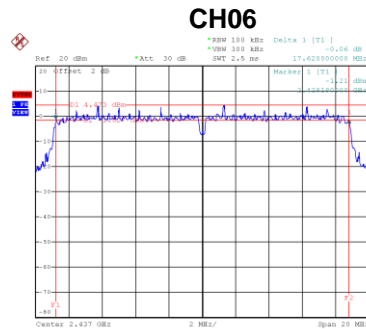

Date: 11.AUG.2020 12:13:145

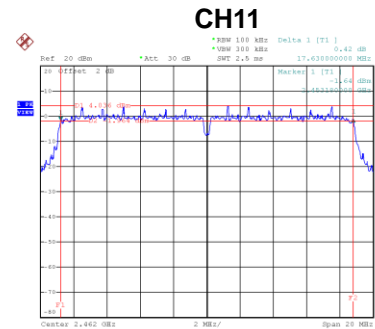

Date: 11.AUG.2020 12:13:136

Channel	Frequency (MHz)	99 % Emission Bandwidth (MHz)	Result
01	2412	18.00	Complies
06	2437	17.92	Complies
11	2462	17.92	Complies

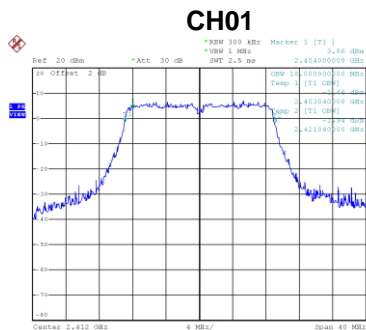

Date: 11.AUG.2020 12:13:137

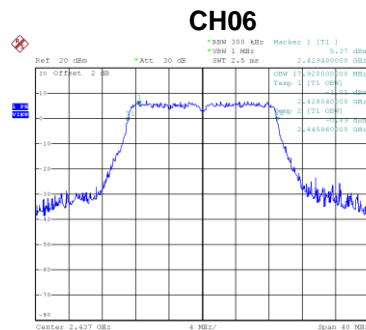

Date: 11.AUG.2020 12:13:151

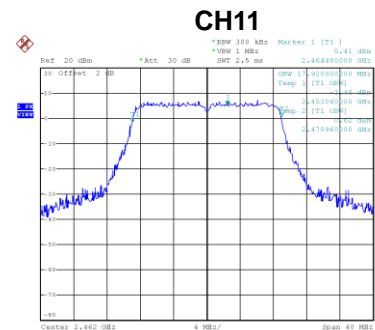

Date: 11.AUG.2020 12:13:143

Test Mode	TX N-40M Mode
-----------	---------------

Channel	Frequency (MHz)	6 dB Bandwidth (MHz)	6 dB Bandwidth Min. Limit (kHz)	Result
03	2422	36.08	500	Complies
06	2437	35.80	500	Complies
09	2452	36.21	500	Complies

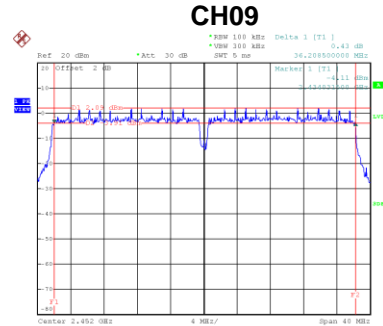
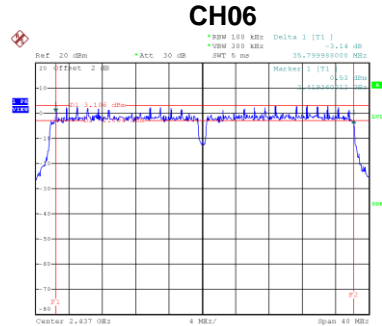
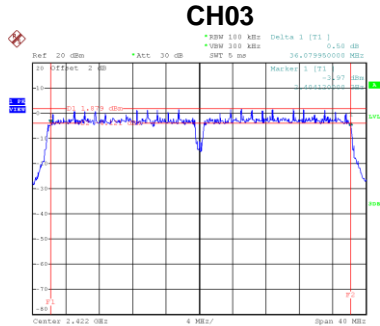

Date: 11.AUG.2020 12:13:124

Date: 11.AUG.2020 13:51:149

Date: 11.AUG.2020 13:53:130

Channel	Frequency (MHz)	99 % Emission Bandwidth (MHz)	Result
03	2422	36.80	Complies
06	2437	36.96	Complies
09	2452	36.96	Complies

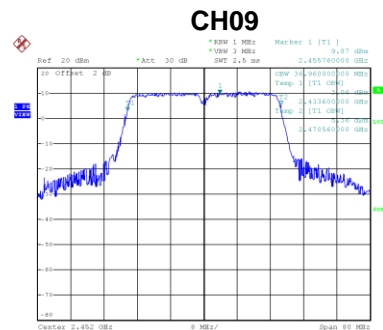
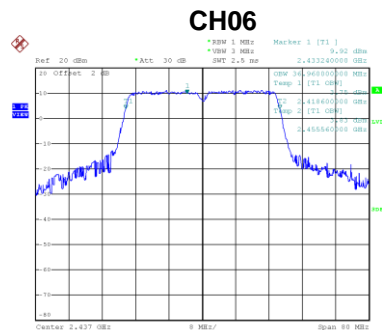
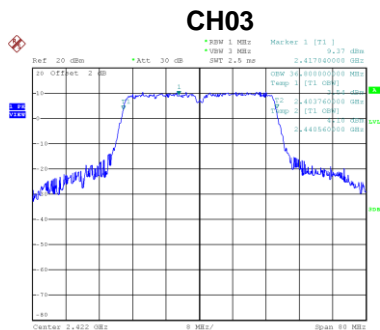

Date: 11.AUG.2020 12:13:131

Date: 11.AUG.2020 13:51:155

Date: 11.AUG.2020 13:53:137

APPENDIX F - MAXIMUM OUTPUT POWER

Test Mode	TX B Mode
-----------	-----------

Channel	Frequency (MHz)	Avg Output Power (dBm)	Duty Factor	Output Power + Duty Factor (dBm)	Max. Limit (dBm)	Max. Limit (W)	Result
01	2412	12.71	0.00	12.71	30.00	1.0000	Complies
06	2437	12.01	0.00	12.01	30.00	1.0000	Complies
11	2462	11.13	0.00	11.13	30.00	1.0000	Complies

Test Mode	TX G Mode
-----------	-----------

Channel	Frequency (MHz)	Avg Output Power (dBm)	Duty Factor	Output Power + Duty Factor (dBm)	Max. Limit (dBm)	Max. Limit (W)	Result
01	2412	14.14	0.35	14.49	30.00	1.0000	Complies
06	2437	14.23	0.35	14.58	30.00	1.0000	Complies
11	2462	14.17	0.35	14.52	30.00	1.0000	Complies

Test Mode	TX N-20M Mode
-----------	---------------

Channel	Frequency (MHz)	Avg Output Power (dBm)	Duty Factor	Output Power + Duty Factor (dBm)	Max. Limit (dBm)	Max. Limit (W)	Result
01	2412	14.26	0.56	14.82	30.00	1.0000	Complies
06	2437	14.02	0.56	14.58	30.00	1.0000	Complies
11	2462	14.22	0.56	14.78	30.00	1.0000	Complies

Test Mode	TX N-40M Mode
-----------	---------------

Channel	Frequency (MHz)	Avg Output Power (dBm)	Duty Factor	Output Power + Duty Factor (dBm)	Max. Limit (dBm)	Max. Limit (W)	Result
03	2422	13.49	1.33	14.82	30.00	1.0000	Complies
06	2437	13.23	1.33	14.56	30.00	1.0000	Complies
09	2452	13.3	1.33	14.63	30.00	1.0000	Complies

APPENDIX G - CONDUCTED SPURIOUS EMISSIONS

Test Mode TX B Mode

Bandedge-CH01

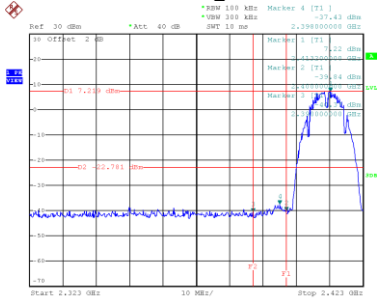

Date: 11.AUG.2020 12:18:48

Bandedge-CH11

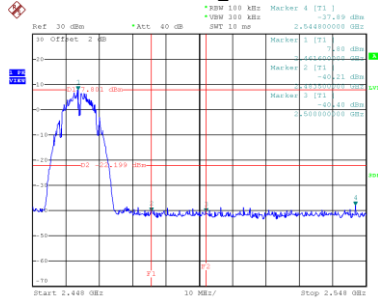

Date: 11.AUG.2020 12:23:57

CH01 – 10th Harmonic of the fundamental frequency

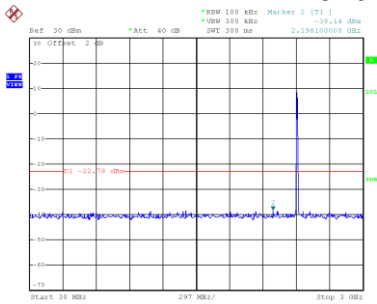

Date: 11.AUG.2020 12:19:03

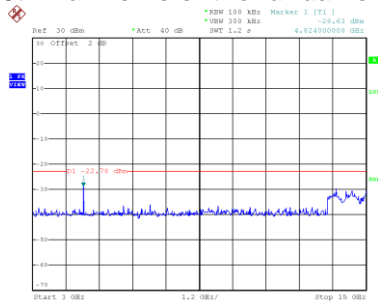

Date: 11.AUG.2020 12:19:10

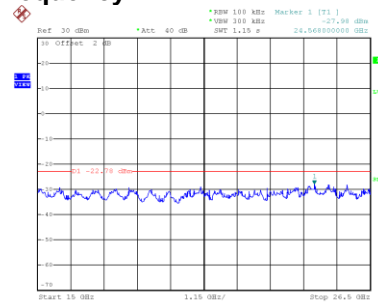

Date: 11.AUG.2020 12:19:17

CH06 – 10th Harmonic of the fundamental frequency

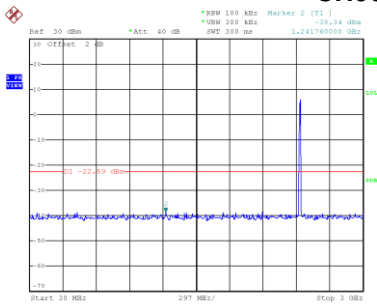

Date: 11.AUG.2020 12:22:22

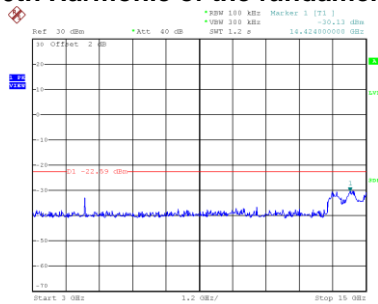

Date: 11.AUG.2020 12:22:30

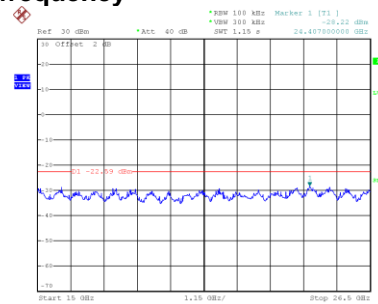

Date: 11.AUG.2020 12:22:37

CH11 – 10th Harmonic of the fundamental frequency

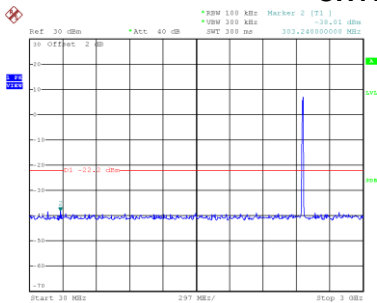

Date: 11.AUG.2020 12:24:10

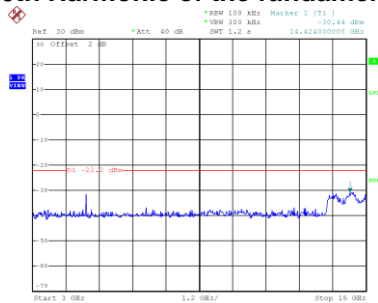

Date: 11.AUG.2020 12:24:17

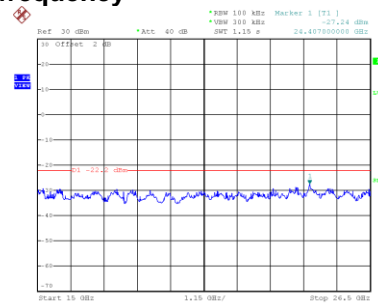

Date: 11.AUG.2020 12:24:24

Test Mode TX G Mode

Bandedge-CH01

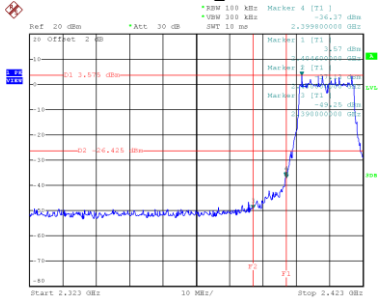

Date: 11.AUG.2020 12:26:10

Bandedge-CH11

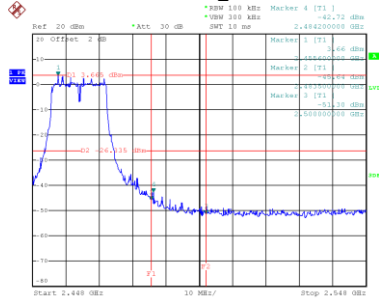

Date: 11.AUG.2020 12:29:09

CH01 – 10th Harmonic of the fundamental frequency

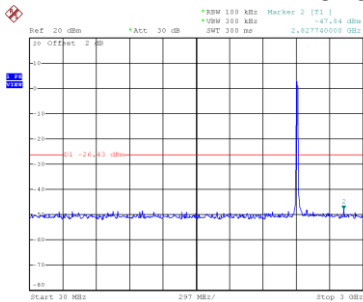

Date: 11.AUG.2020 12:26:12

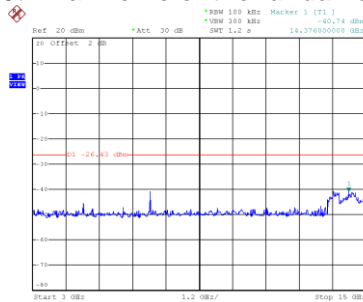

Date: 11.AUG.2020 12:26:30

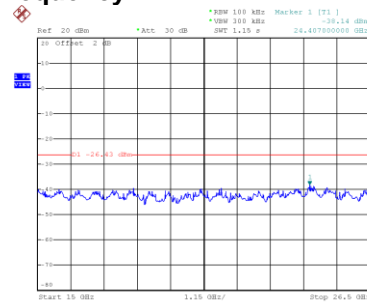

Date: 11.AUG.2020 12:26:38

CH06 – 10th Harmonic of the fundamental frequency

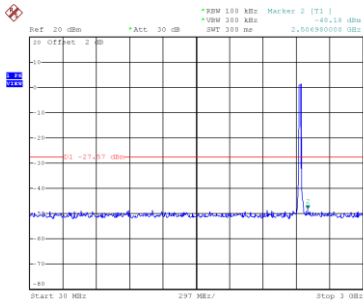

Date: 11.AUG.2020 12:31:42

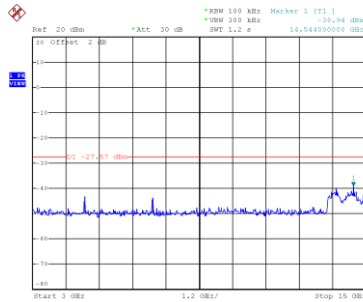

Date: 11.AUG.2020 12:31:49

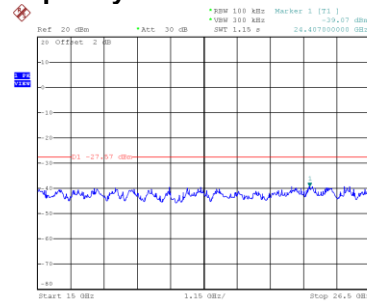

Date: 11.AUG.2020 12:31:56

CH11 – 10th Harmonic of the fundamental frequency

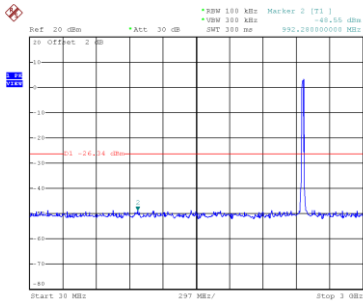

Date: 11.AUG.2020 12:29:23

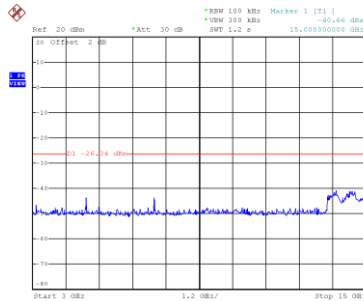

Date: 11.AUG.2020 12:29:30

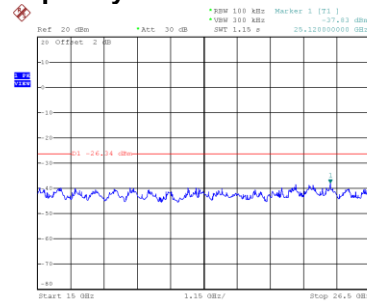

Date: 11.AUG.2020 12:29:37

Test Mode TX N-40M Mode

Bandedge-CH03

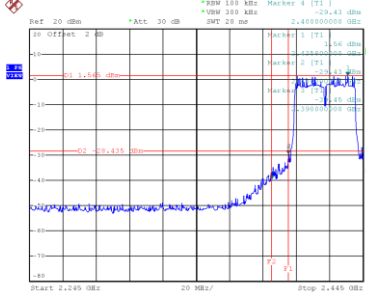

Date: 11.AUG.2020 12:39:38

Bandedge-CH09

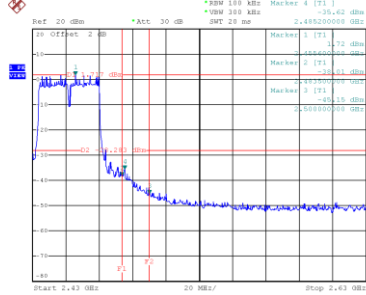

Date: 11.AUG.2020 13:53:44

CH03 – 10th Harmonic of the fundamental frequency

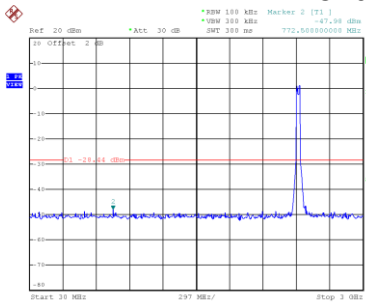

Date: 11.AUG.2020 12:39:51

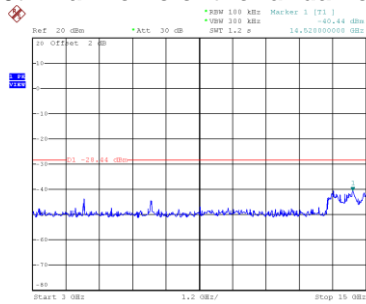

Date: 11.AUG.2020 12:39:58

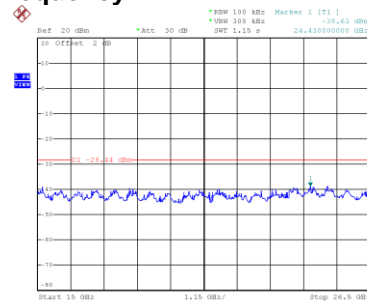

Date: 11.AUG.2020 12:40:05

CH06 – 10th Harmonic of the fundamental frequency

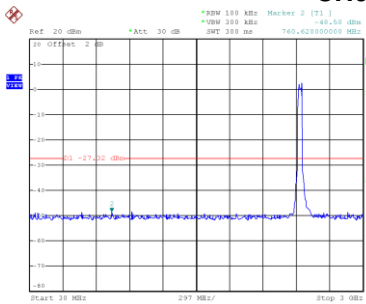

Date: 11.AUG.2020 13:52:16

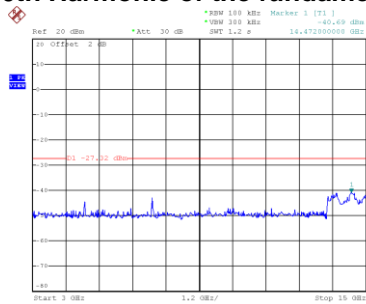

Date: 11.AUG.2020 13:52:23

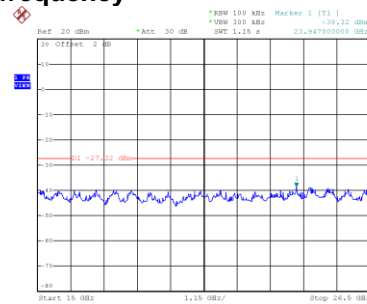

Date: 11.AUG.2020 13:52:30

CH09 – 10th Harmonic of the fundamental frequency

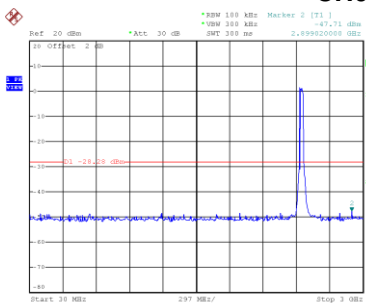

Date: 11.AUG.2020 13:53:58

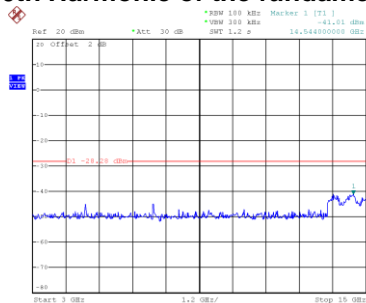

Date: 11.AUG.2020 13:54:05

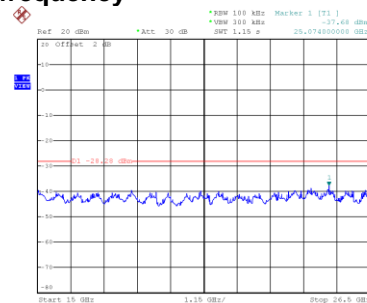

Date: 11.AUG.2020 13:54:12

APPENDIX H - POWER SPECTRAL DENSITY

Test Mode	TX B Mode
-----------	-----------

Channel	Frequency (MHz)	Power Spectral Density (dBm/3kHz)	Max. Limit (dBm/3kHz)	Result
01	2412	-6.47	8	Complies
06	2437	-6.64	8	Complies
11	2462	-8.23	8	Complies

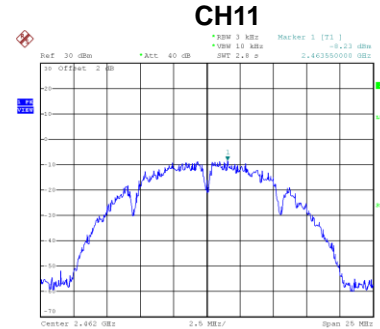
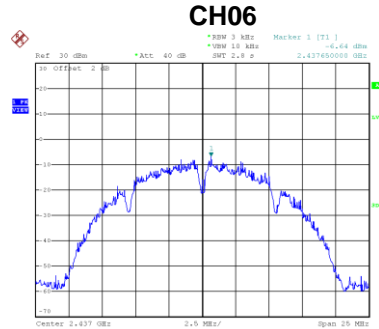
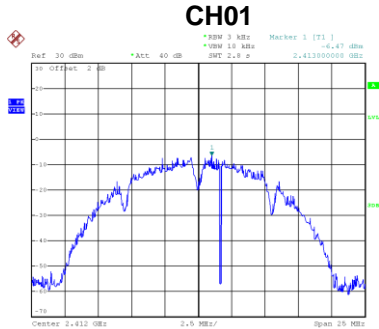

Test Mode	TX G Mode
-----------	-----------

Channel	Frequency (MHz)	Power Spectral Density (dBm/3kHz)	Max. Limit (dBm/3kHz)	Result
01	2412	-10.46	8	Complies
06	2437	-11.10	8	Complies
11	2462	-10.87	8	Complies

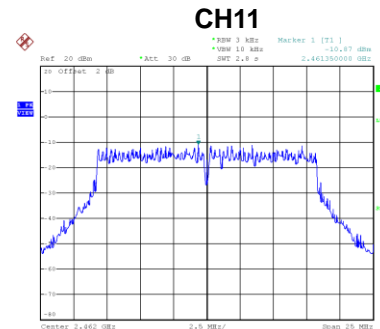
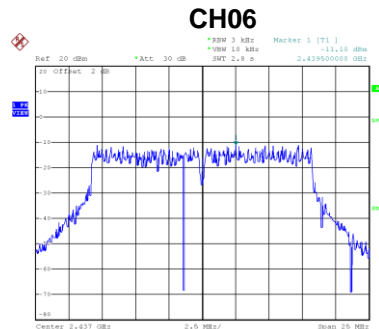
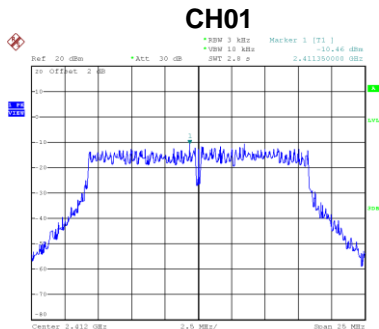

Test Mode	TX N-20M Mode
-----------	---------------

Channel	Frequency (MHz)	Power Spectral Density (dBm/3kHz)	Max. Limit (dBm/3kHz)	Result
01	2412	-11.29	8	Complies
06	2437	-10.74	8	Complies
11	2462	-10.43	8	Complies

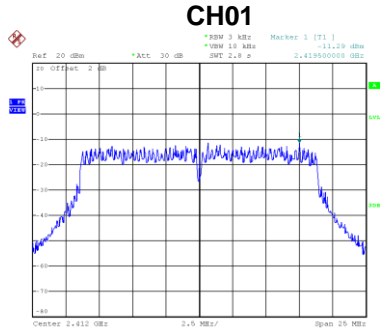

Date: 11.AUG.2020 12:13:120

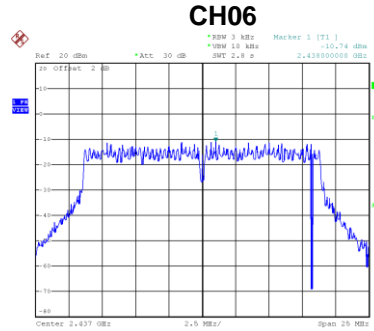

Date: 11.AUG.2020 12:13:135

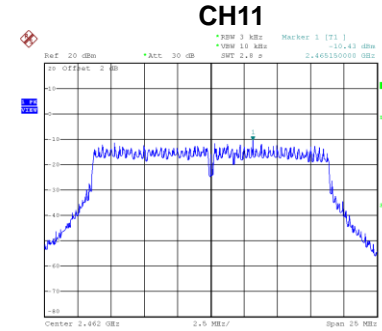

Date: 11.AUG.2020 12:13:126

Test Mode	TX N-40M Mode
-----------	---------------

Channel	Frequency (MHz)	Power Spectral Density (dBm/3kHz)	Max. Limit (dBm/3kHz)	Result
03	2422	-12.49	8	Complies
06	2437	-13.09	8	Complies
09	2452	-11.90	8	Complies

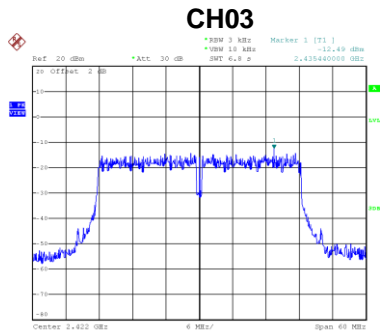

Date: 11.AUG.2020 12:14:17

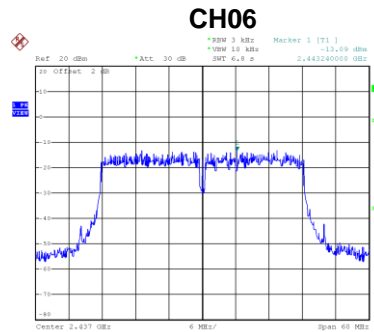

Date: 11.AUG.2020 13:15:142

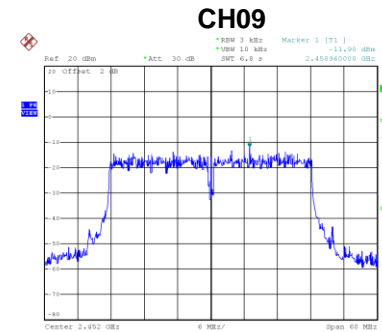

Date: 11.AUG.2020 13:15:123

End of Test Report