



CB3S Module User Guide

Version: 20220819



CB3S is a low-power embedded module that Feit has developed. It consists of a RF chip BK7231 N and a few peripherals.

1 Product overview

CB3S is built in with a 32-bit MCU whose running speed can be up to 120 MHz, a 2-MB flash memory, and a 256-KB RAM, to support the Feit cloud connection. The MCU instructions specially extended for signal processing can effectively implement audio encoding and decoding.

Besides, it has rich peripherals, such as PWM and UART. There are 5 channels of 32-bit PWM output, making the chip very suitable for high-quality LED control.

1.1 Features

- Built in with the low-power 32-bit CPU, which can also function as an application processor
- The clock rate: 120 MHz
- Working voltage: 3.3V
- Peripherals: 5 PWMs and 1 UART
- Wi-Fi connectivity
 - 802.11 b/g/n
 - Channels 1 to [11@2.4](#) GHz
 - Support WEP, WPA/WPA2, WPA/WPA2 PSK (AES), WPA3 security modes
 - output power < 20 dBm
 - Support STA/AP/STA+AP working mode
 - Support SmartConfig and AP network configuration manners for Android and iOS devices
 - Onboard PCB antenna with a gain of 1.3 dBi
 - Working temperature: -40°C to 85°C

1.2 Applications

- Intelligent building
-

- Smart household and home appliances
 - Smart socket and light
 - Industrial wireless control
 - Baby monitor
 - Network camera
 - Intelligent bus
-

2 Module interfaces

2.1 Dimensions and package

The dimensions of CB3S are 16.00 ± 0.35 mm (W) \times 24.00 ± 0.35 mm (L) \times 2.8 ± 0.15 mm (H). The dimensions of CB3S are as follows:

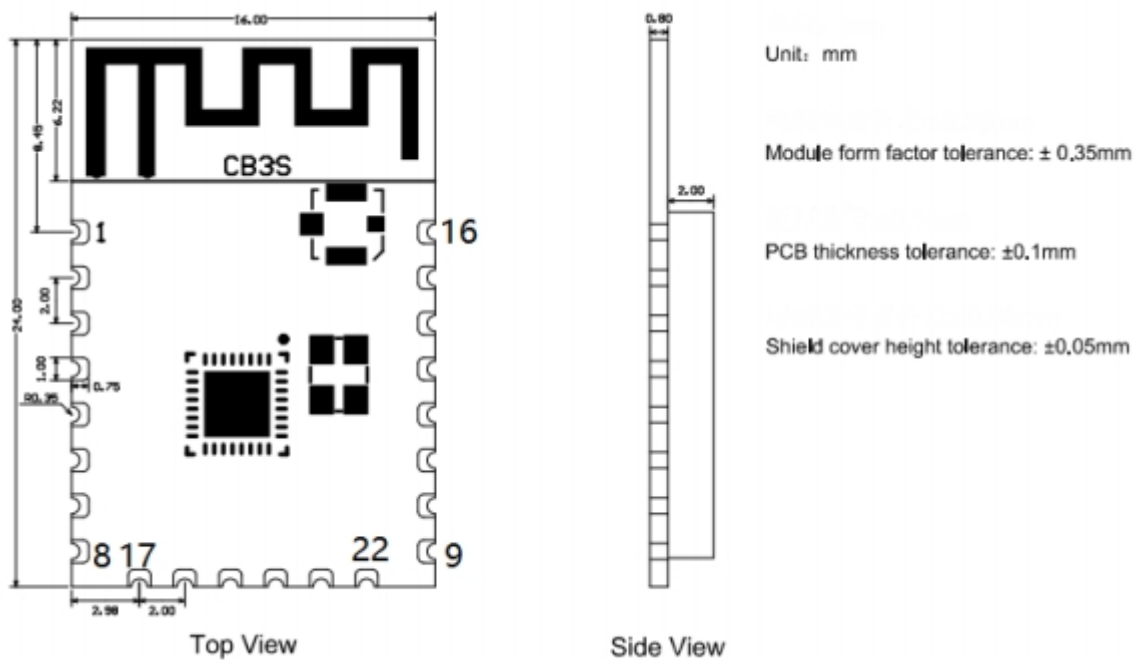

2.2 Pin definition

Pin number	Symbol	I/O type	Function
1	RST	I	Low-level reset, high level active (the pin has been pulled high internally), correspond to CEN of the IC

Pin number	Symbol	I/O type	Function
2	ADC3	AI	ADC pin, which corresponds to P23 of the IC
3	CEN	I	Enabling pin, which is pulled high internally to be compatible with other modules
4	P14	I/O	A common GPIO interface, which corresponds to P14 of the IC
5	P26	I/O	GPIOP_26, which corresponds to P26 of the IC, PWM 5
6	P24	I/O	GPIOP_24, which corresponds to P24 of the IC, PWM 4
7	P6	I/O	GPIOP_6, which corresponds to P6 of the IC, PWM 0
8	VCC	P	Power supply pin (3.3V)
9	GND	P	Power supply reference ground
10	P9	I/O	GPIOP_9, which corresponds to P9 of the IC, PWM 3

Pin number	Symbol	I/O type	Function
11	TXD2	I/O	UART2_TXD (used to display the module internal information), which corresponds to P0 of the IC
12	CSN	I/O	Production test control pin. If it is used as a common I/O pin, it must be connected to the VCC externally. Do not connect it to the ground before the module is powered on.
13	P8	I/O	GPIOP_8, which corresponds to P8 of the IC, PWM 2
14	P7	I/O	GPIOP_7, which corresponds to P7 of the IC, PWM 1
15	RXD1	I/O	UART1_RXD (user serial interface), which corresponds to P10 of the IC. Do not connect it to the VCC. By default, the MCU serial port should be in low-level or high-impedance state.

Pin number	Symbol	I/O type	Function
16	TXD1	I/O	UART1_TXD (user serial interface), which corresponds to P11 of the IC. Do not connect it to the VCC. By default, the MCU serial port should be in low-level or high-impedance state.
17	ADC3	AI	(Not recommended. If needed, please use Pin 2) ADC port, which corresponds to P23 of the IC. Programmed SPI
18	P22	I/O	(Not recommended) GPIOP_22, which corresponds to P22 of the IC. Programmed SPI

Pin number	Symbol	I/O type	Function
19	CSN	I/O	The pull-up resistor is needed during usage of customers. Do not connect it to the ground before the module is powered on. Correspond to P21 of the IC.
20	P20	I/O	(Not recommended.) GPIOP_20, which corresponds to P20 of the IC. Programmed SPI
21	NC	-	-
22	NC	-	-

Note: P indicates a power supply pin and I/O indicates an input/output pin. For the MCU solution, please refer to [CBx Module](#).

3 Electrical parameters

3.1 Absolute electrical parameters

Parameter	Description	Minimum value	Maximum value	Unit
Ts	Storage temperature	-55	125	°C
ESD voltage (human body model)	TAMB-25°C	-4	4	KV
ESD voltage (machine model)	TAMB-25°C	-200	200	V

3.2 Normal working conditions

Parameter	Description	Minimum value	Typical value	Maximum value	Unit
Ta	Working temperature	-40	-	85	°C



Parameter	Description	Minimum value	Typical value	Maximum value	Unit
I _{max}	I/O drive current	-	6	20	mA

3.3 RF power consumption

Frequency Range	Wi-Fi: 2412-2462MHz
Maximum Conducted AV Output Power	Wi-Fi: 19.03dBm(802.11b), 19.20dBm(802.11g), 19.30dBm(802.11n20), 18.10dBm(802.11n40)

3.4 Working current

Working mode	Working status, Ta = 25°C	Average value	Maximum value (Typical value)	Unit
Quick network connection state (AP)	The module is in the hotspot network connection state and the Wi-Fi indicator flashes slowly.	80	270	mA
Quick network connection state (EZ)	The module is in the fast network connection state and the Wi-Fi indicator flashes fast.	78	246	mA
Connected	The module is connected to the network and the Wi-Fi indicator is always on.	25	342	mA

Working mode	Working status, Ta = 25°C	Average value	Maximum value (Typical value)	Unit
Weakly connected	The module and the hotspot are weakly connected and the Wi-Fi indicator light is always on	205	350	mA
Disconnected	The module is disconnected and the Wi-Fi indicator is always off.	63	242	mA
Module disabled	The CEN pin of the module is connected to the ground.	330	-	μA

4 RF parameters

Parameter	Description
Working frequency	2.412 to 2.46 GHz
Wi-Fi standard	IEEE 802.11 b/g/n (channels 1 to 11)
Data transmission rate	11b: 1, 2, 5.5, 11 (Mbps) 11g: 6, 9, 12, 18, 24, 36, 48, 54 (Mbps) 11n: HT20 MCS 0 to 7 11n: HT40 MCS 0 to 7
Antenna type	PCB antenna

5 Antenna information

5.1 Antenna type

CB3S uses the PCB antenna with a gain of 1.3 dBi.

5.2 Antenna interference reduction

To ensure optimal Wi-Fi performance when the Wi-Fi module uses an onboard PCB antenna, it is recommended that the antenna be at least 15 mm away from other metal parts.

To prevent adverse impact on the antenna radiation performance, avoid copper or traces within the antenna area on the PCB.

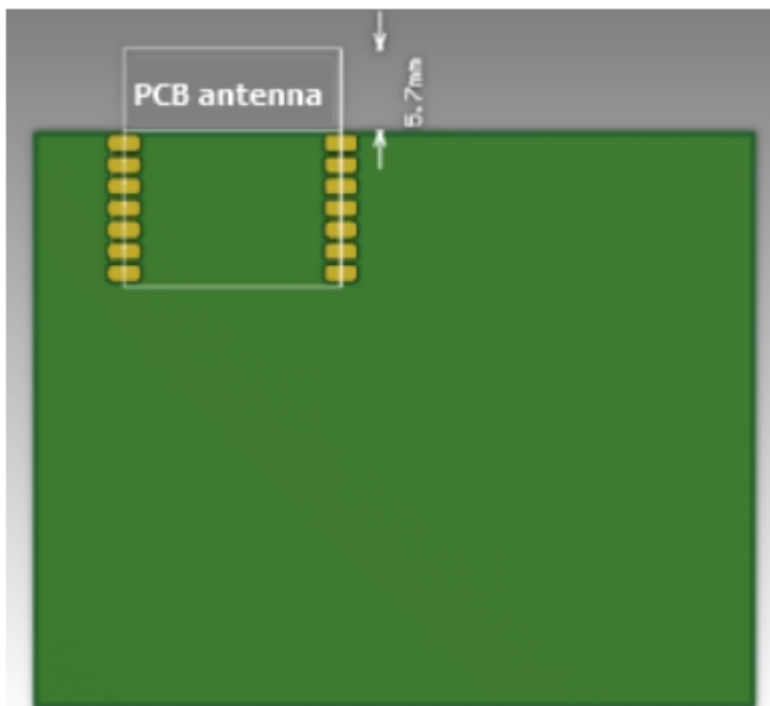

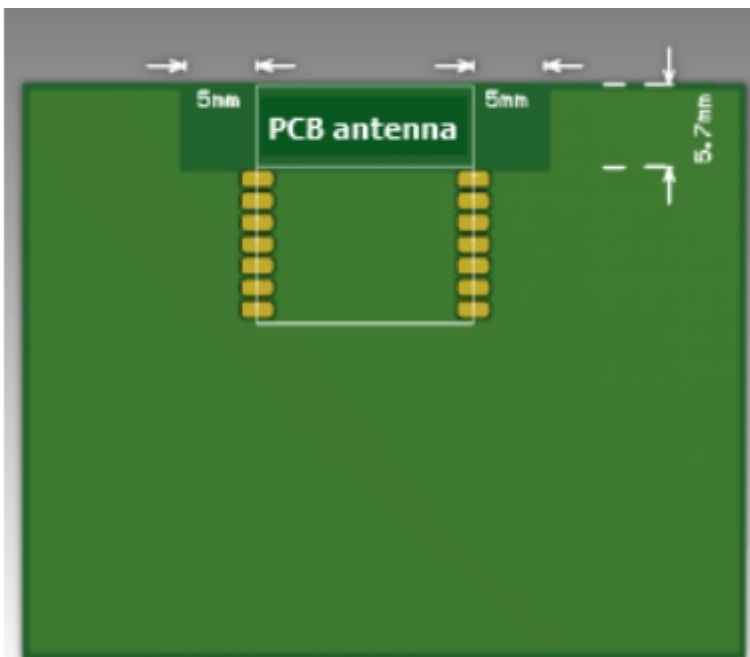
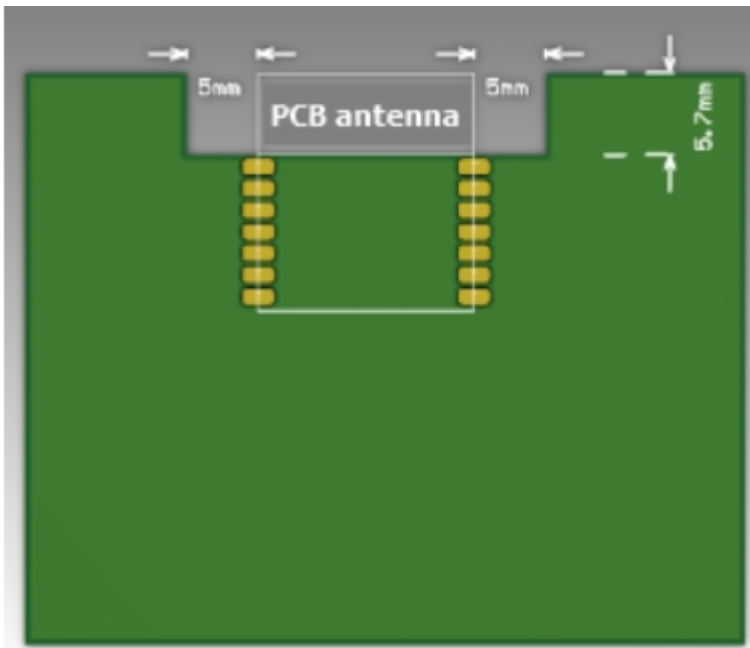

**Do not place any metal in the red area above the antenna.
The recommended diameter of the circular arc is greater than 3 cm.**

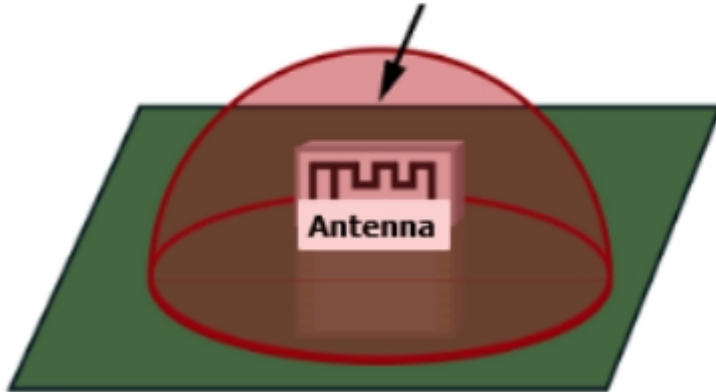

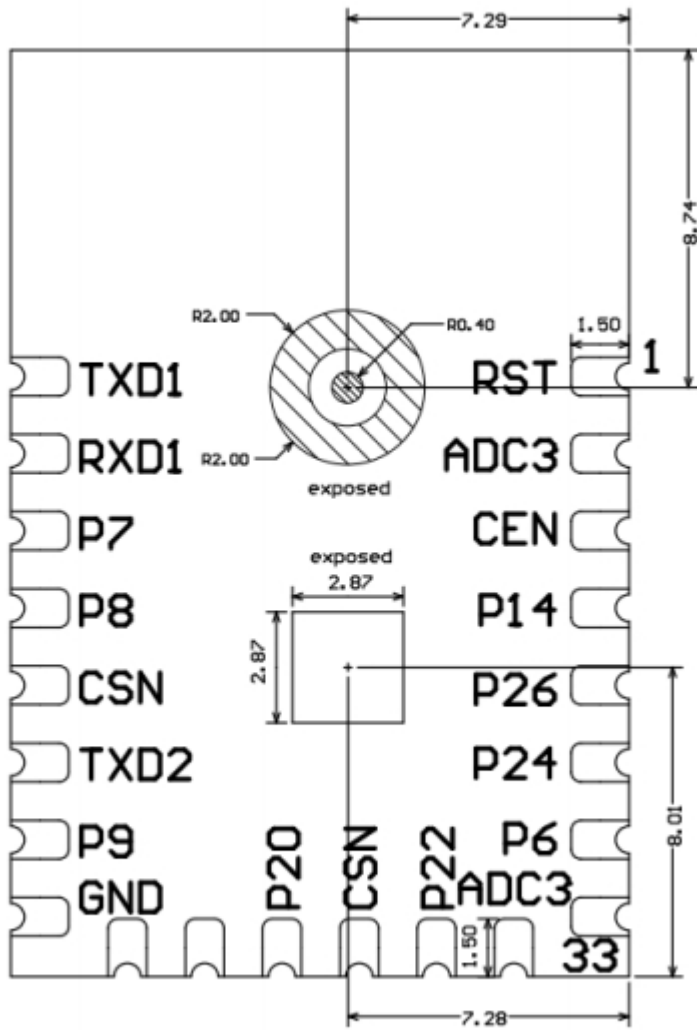

Bottom View



Unit: mm

Module form factor tolerance: $\pm 0.35\text{mm}$

PCB thickness tolerance: $\pm 0.1\text{mm}$

Shield case height tolerance: $\pm 0.05\text{mm}$

Side View

6.2 Production instructions

1. The Tuya SMT module should be mounted by the SMT device. After being unpacked, it should be soldered within 24 hours. Otherwise, it should be put into the drying cupboard where the RH is not greater than 10%; or it needs to be packaged under vacuum again and the exposure time needs to be recorded (the total exposure time cannot exceed 168 hours).

- SMT devices:
 - Mounter
 - SPI
 - Reflow soldering machine
 - Thermal profiler
 - Automated optical inspection (AOI) equipment
- Baking devices:
 - Cabinet oven
 - Anti-electrostatic and heat-resistant trays
 - Anti-electrostatic and heat-resistant gloves

2. Storage conditions for a delivered module:

- The moisture-proof bag must be placed in an environment where the temperature is below 40°C and the relative humidity is lower than 90%.
- The shelf life of a dry-packaged product is 12 months from the date when the product is packaged and sealed.
- There is a humidity indicator card (HIC) in the packaging bag.



Figure 1: HIC-SMT module.png

3. The module needs to be baked in the following cases:

- The packaging bag is damaged before unpacking.
-

- There is no HIC in the packaging bag.
- After unpacking, circles of 10% and above on the HIC become pink.
- The total exposure time has lasted for over 168 hours since unpacking.
- More than 12 months have passed since the sealing of the bag.

4. Baking settings:

- Temperature: 40°C and $\leq 5\%$ RH for reel package and 125°C and $\leq 5\%$ RH for tray package (please use the heat-resistant tray rather than plastic container)
- Time: 168 hours for reel package and 12 hours for tray package
- Alarm temperature: 50°C for reel package and 135°C for tray package
- Production-ready temperature after natural cooling: $< 36^\circ\text{C}$
- Re-baking situation: If a module remains unused for over 168 hours after being baked, it needs to be baked again.
- If a batch of modules is not baked within 168 hours, do not use the reflow soldering to solder them. Because these modules are Level-3 moisture-sensitive devices, they are very likely to get damp when exposed beyond the allowable time. In this case, if they are soldered at high temperatures, it may result in device failure or poor soldering.

5. In the whole production process, take electrostatic discharge (ESD) protective measures.
6. To guarantee the passing rate, it is recommended that you use the SPI and AOI to monitor the quality of solder paste printing and mounting.

6.3 Recommended oven temperature curve

Set oven temperatures according to the following temperature curve of reflow soldering. The peak temperature is 245°C.

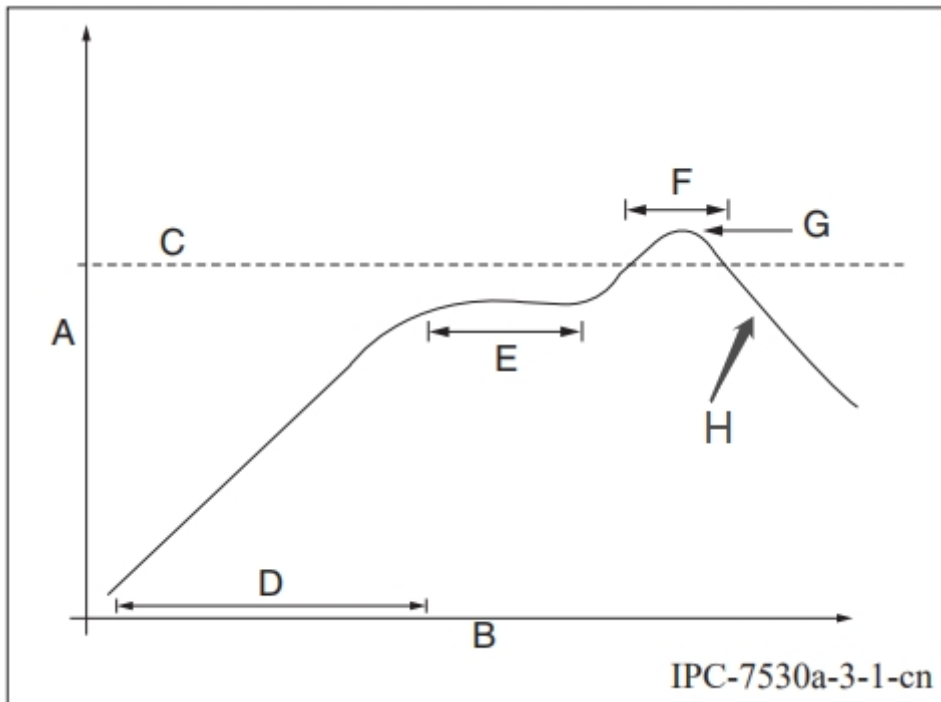

- A: Temperature axis
- B: Time axis
- C: Liquidus temperature: 217 to 220°C
- D: Ramp-up slope: 1 to 3°C/s
- E: Duration of constant temperature: 60 to 120s; the range of constant temperature: 150 to 200°C
- F: Duration above the liquidus: 50 to 70s
- G: Peak temperature: 235 to 245°C
- H: Ramp-down slope: 1 to 4°C/s

Note: The above curve is just an example of the solder paste SAC305. For more details about other solder pastes, please refer to Recommended oven temperature curve in the solder paste specifications.



7 MOQ and packaging information

Product model	MOQ (pcs)	Packaging method	Number of modules per reel	Number of reels per carton
CB3S	3600	Tape reel	900	4



8 Appendix: Statement

FCC Caution: Any changes or modifications not expressly approved by the party responsible for compliance could void the user's authority to operate this device.

This device complies with Part 15 of the FCC Rules. Operation is subject to the following two conditions: (1) This device may not cause harmful interference, and (2) this device must accept any interference received, including interference that may cause undesired operation.

Note: This device has been tested and found to comply with the limits for a Class B digital device, according to part 15 of the FCC Rules. These limits are designed to provide reasonable protection against harmful interference in a residential installation. This device generates, uses, and can radiate radio frequency energy and, if not installed and used following the instructions, may cause harmful interference to radio communications. However, there is no guarantee that interference will not occur in a particular installation.

If this device does cause harmful interference to radio or television reception, which can be determined by turning the device off and on, the user is encouraged to try to correct the interference by one or more of the following measures:

- Reorient or relocate the receiving antenna.
- Increase the separation between the device and receiver.
- Connect the device to an outlet on a circuit different from that to which the receiver is connected.
- Consult the dealer or an experienced radio/TV technician for help.

Radiation Exposure Statement

This device complies with FCC radiation exposure limits set forth for an uncontrolled rolled environment. This device should be installed and operated with a minimum distance of 20cm between the radiator and your body.

Important Note

This radio module must not be installed to co-locate and operate simultaneously with other radios in the host system except following FCC multi-transmitter product procedures. Additional testing and device authorization may be required to operate simultaneously with other radios.

The availability of some specific channels and/or operational frequency bands are country-dependent and are firmware programmed at the factory to match the intended destination. The firmware setting is not accessible by the end-user.

The host product manufacturer is responsible for compliance with any other FCC rules that apply to the host not covered by the modular transmitter grant of certification. The final host product still requires Part 15 Subpart B compliance testing with the modular transmitter installed.

The end-user manual shall include all required regulatory information/warnings as shown in this manual, including “This product must be installed and operated with a minimum distance of 20 cm between the radiator and user body” .

This device has got an FCC ID: SYW-ALRTMPWIFI. The end product must be labeled in a visible area with the following: “Contains Transmitter Module FCC ID: SYW-ALRTMPWIFI”

This device is intended only for OEM integrators under the following conditions:

The antenna must be installed such that 20cm is maintained between the antenna and users, and the transmitter module may not be co-located with any other transmitter or antenna.

As long as the 2 conditions above are met, further transmitter tests will not be required. However, the OEM integrator is still responsible for testing their end-product for any additional compliance requirements required with this module installed.

Declaration of Conformity European Notice



Hereby, Feit Electric Company declares that this module product complies with essential requirements and other relevant provisions of Directive 2014/53/EU, 2011/65/EU. A copy of the Declaration of conformity can be found at <https://www.feit.com>.



This product must not be disposed of as normal household waste, in accordance with the EU directive for waste electrical and electronic equipment (WEEE-2012/19/EU). Instead, it should be disposed of by returning it to the point of sale, or a municipal recycling collection point.

The device could be used with a separation distance of 20cm from the human body.

Industry Canada Statement

This device complies with Industry Canada's license-exempt RSSs. Operation is subject to the following two conditions: (1) This device may not cause interference; and (2) this device must accept any interference, including interference that may cause undesired operation of the device.

Le présent appareil est conforme aux CNR d' Industrie Canada applicables aux appareils radio exempts de licence. L' exploitation est autorisée aux deux conditions suivantes: (1) l' appareil ne doit pas produire de brouillage, et (2) l' utilisateur de l' appareil doit accepter tout brouillage radioélectrique subi, même si le brouillage est susceptible d' en compromettre le fonctionnement."

Radiation Exposure Statement

This equipment complies with IC radiation exposure limits set forth for an uncontrolled environment. This equipment should be installed and operated with a minimum distance of 20 cm between the radiator & your body.

Déclaration d' exposition aux radiations

Cet équipement est conforme aux limites d' exposition aux rayonnements ISED établies pour un environnement non contrôlé. Cet équipement doit être installé et utilisé avec un minimum de 20 cm de distance entre la source de rayonnement et votre corps.

This device is intended only for OEM integrators under the following conditions:

- The antenna must be installed such that 20 cm is maintained between the antenna and users, and
- The transmitter module may not be co-located with any other transmitter or antenna.

As long as the 2 conditions above are met, further transmitter tests will not be required. However, the OEM integrator is still responsible for testing their end-product for any additional compliance requirements required with this module installed.

Cet appareil est conçu uniquement pour les intégrateurs OEM dans les conditions suivantes:

- L' antenne doit être installée de telle sorte qu' une distance de 20 cm est respectée entre l' antenne et les utilisateurs, et
- Le module émetteur peut ne pas être coïmplanté avec un autre émetteur ou antenne.

Tant que les 2 conditions ci-dessus sont remplies, des essais supplémentaires sur l' émetteur ne seront pas nécessaires. Toutefois, l' intégrateur OEM est toujours responsable des essais sur son produit final pour toutes exigences de conformité supplémentaires requis pour ce module installé.

Important Note

In the event that these conditions can not be met (for example certain laptop configurations or colocation with another transmitter), then the Canada authorization is no longer considered valid and the IC ID can not be used on the final product. In these circumstances, the OEM integrator will be responsible for re-evaluating the end product (including the transmitter) and obtaining a separate Canada authorization.

Note Importante

Dans le cas où ces conditions ne peuvent être satisfaites (par exemple pour certaines configurations d' ordinateur portable ou de certaines co-localisation avec un autre émetteur), l' autorisation du Canada n' est plus considéré comme valide et l' ID IC ne peut pas être utilisé sur le produit final. Dans ces circonstances, l' intégrateur OEM sera chargé de réévaluer le produit final (y compris l' émetteur) et l' obtention d' une autorisation distincte au Canada.

End Product Labeling

This transmitter module is authorized only for use in devices where the antenna may be installed such that 20 cm may be maintained between the antenna and



users. The final end product must be labelled in a visible area with the following: “Contains IC: 20416-CB3S” .

Plaque signalétique du produit final

Ce module émetteur est autorisé uniquement pour une utilisation dans un dispositif où l’ antenne peut être installée de telle sorte qu’ une distance de 20cm peut être maintenue entre l’ antenne et les utilisateurs. Le produit final doit être étiqueté dans un endroit visible avec l’ inscription suivante: “Contient des IC:20416-CB3S” .

Manual Information To End User

The OEM integrator has to be aware not to provide information to the end user regarding how to install or remove this RF module in the user’ s manual of the end product which integrates this module. The end-user manual shall include all required regulatory information/warning as shown in this manual.

Manuel d’ information à l’ utilisateur final

L’ intégrateur OEM doit être conscient de ne pas fournir des informations à l’ utilisateur final quant à la façon d’ installer ou de supprimer ce module RF dans le manuel de l’ utilisateur du produit final qui intègre ce module. Le manuel de l’ utilisateur final doit inclure toutes les informations réglementaires requises et avertissements comme indiqué dans ce manuel.

2.2 List of applicable FCC rules

CFR 47 FCC PART 15 SUBPART C/E has been investigated. It is applicable to the modular.

2.3 Specific operational use conditions

This module is stand-alone modular. If the end product will involve the Multiple simultaneously transmitting condition or different operational conditions for a stand-alone modular transmitter in a host, host manufacturer have to consult with module manufacturer for the installation method in end system.

2.4 Limited module procedures

Not applicable

2.5 Trace antenna designs

Not applicable

2.6 RF exposure considerations

To maintain compliance with FCC's RF Exposure guidelines, This equipment should be installed and operated with minimum distance of 20cm from your body.

2.7 Antennas

This radio transmitter FCC ID: SYW-ALRTMPWIFI has been approved by Federal Communications Commission to operate with the antenna types listed below, with the maximum permissible gain indicated. Antenna types not included in this list that have a gain greater than the maximum gain indicated for any type listed are strictly prohibited for use with this device.

No.	Antenna Type	ANT	Antenna Gain	Impedance	Frequency Range
1	PCB	Wi-Fi ANT	1.3dBi	50Ω	2.4~2.5GHz

2.8 Label and compliance information

The final end product must be labeled in a visible area with the following" Contains FCC ID: SYW-ALRTMPWIFI"

2.9 Information on test modes and additional testing requirements

Host manufacturer is strongly recommended to confirm compliance with FCC requirements for the transmitter when the module is installed in the host.

2.10 Additional testing, Part 15 Subpart B disclaimer

Host manufacturer is responsible for compliance of the host system with module installed with all other applicable requirements for the system such as Part 15 B.