

Miele

Operating instructions

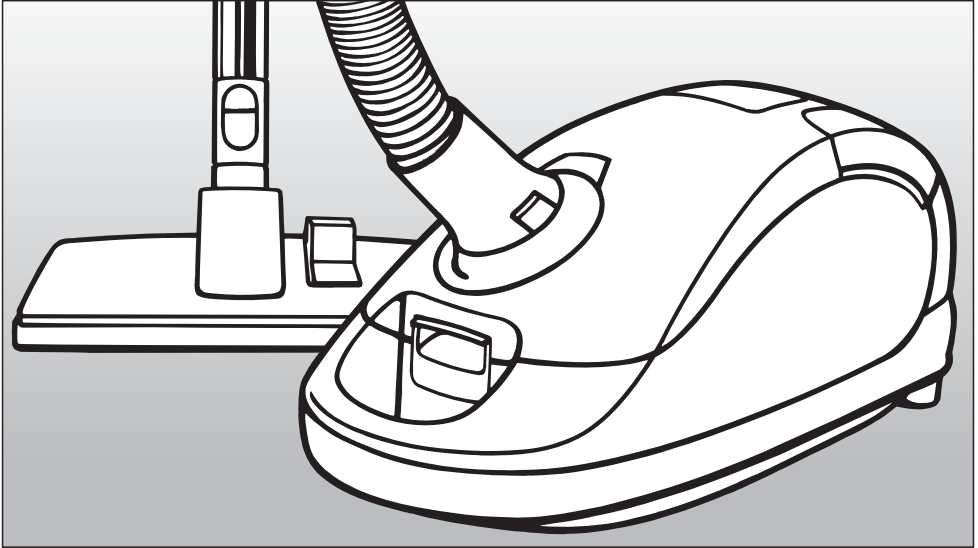

Vacuum cleaner S 4000

To prevent accidents
and machine damage,
read these instructions
before installation and use.

HS10

USA CDN

M.-Nr. 06 xxx xxx

IMPORTANT SAFETY INSTRUCTIONS	4
CONSIGNES DE SÉCURITÉ IMPORTANTES	9
Guide to the machine.	14
Before using the vacuum cleaner.	16
Using the included accessories	19
Operation	21
Power cord.	21
Turning the vacuum on and off	21
Adjusting the suction	23
Opening the air inlet valve.	25
Transport and storage	26
Maintenance and care	27
Purchasing new dustbags and filters	27
When to change the dustbag	28
Replacing the dustbag	29
Replacing the exhaust filter	30
Exhaust filter change indicator	31
Replacing the "SUPER air clean" filter	32
Replacing the "ActiveAirClean Plus" filter and the "Active HEPA Plus" filter	33
Replacing one type of filter with another	34
When to change the dust compartment filter (motor protection).	35
Replacing the dust compartment filter (motor protection).	35
When to change the radio handpiece battery	35
How to change the radio handpiece battery	35
When to change the thread catcher pads.	36
Replacing the thread catchers	36
Cleaning and care	37
Frequently asked questions	38
Optional accessories.	39
Caring for the environment	44

IMPORTANT SAFETY INSTRUCTIONS

When using an electrical appliance, basic precautions should always be followed, including the following:

READ ALL INSTRUCTIONS BEFORE USING THIS APPLIANCE

The manufacturer cannot be held responsible for any damage caused by non-compliance of these Important Safety Instructions.

WARNING-

To reduce the risk of fire, electric shock or injury:

Before using

■ Check the voltage rating of the vacuum cleaner before connecting the power cord to an electrical outlet. Your power source should correspond with the voltage rating plate located on the underside of the vacuum. Use only household AC outlets. Never use DC power sources. If you are not sure of your home's voltage supply, consult a qualified electrician. Connecting the vacuum cleaner to a higher voltage than indicated in these instructions may result in damage to the vacuum cleaner or injury.

■ To reduce the risk of electric shock, this appliance has a polarized plug (one blade is wider than the other.) This plug will fit in a polarized outlet only one way. If the plug does not fit fully in the outlet, reverse the plug. If it still does not fit, contact a qualified electrician to install the proper outlet. Do not alter the plug in any way.

■ A damaged vacuum cleaner can be dangerous. Check the packaging, the vacuum cleaner and accessories for any signs of damage. Do not use a damaged appliance.

■ Do not use with a damaged cord or plug. If the appliance is not working as it should, has been dropped, damaged, left outdoors or submerged in water, bring it to a service center.

■ The electrical outlet must be fitted with a 15 A fuse.

IMPORTANT SAFETY INSTRUCTIONS

Use

Do not use on people or on animals.

Do not use outdoors or on wet surfaces. Only **dry** surfaces should be vacuumed.

Use only as described in this manual. Use only Miele recommended accessories.

The hose and the telescopic wand contain electrical wires. Do not use the vacuum cleaner if these parts are damaged in any way. Danger of electric shock!

The manufacturer cannot be held responsible for damage caused by non-compliance with these Important Safety Instructions. This appliance is intended strictly for household use only.

This vacuum should not be used to entrap or retain any hazardous materials.

Do not allow the vacuum cleaner to be used as a toy. Close attention is necessary when used near children.

Do not pull or carry by the cord, use the cord as a handle, close a door on the cord, or pull the cord around sharp edges or corners. Do not run the appliance over the cord. Keep the cord away from heated surfaces.

Do not unplug by pulling on the cord. To unplug, grasp the plug, not the cord.

Do not handle the plug or vacuum with wet hands.

Keep hair, loose clothing, fingers and all parts of the body away from openings and moving parts.

Turn off all controls before unplugging.

Use extra care when cleaning on stairs.

Floor attachments, accessories and wands must not be used at head level to avoid injury to eyes and ears.

Do not use to pick up flammable or combustible liquids, such as gasoline, or use in areas where they may be present.

Do not use the vacuum cleaner to pick up liquids, this could impair the electrical safety of the vacuum cleaner. Wait for freshly shampooed carpets to dry.

Do not vacuum anything that is burning or smoking, such as cigarettes, matches, or hot ashes.

Do not vacuum up items which are heavy, hard or have sharp edges. They could cause a blockage and damage the appliance.

Do not vacuum toner dust. Toner, such as that used in printers and photocopiers can conduct electricity.

Unplug the vacuum when changing accessories, especially the Turbobrush and Rechargeable Battery brush.

IMPORTANT SAFETY INSTRUCTIONS

Do not turn on or attempt to operate the vacuum cleaner unless a dustbag, dust compartment filter and exhaust filter are in place. Use only genuine Miele double-layer dustbags and filters. See "Maintenance and care" for instructions on how to insert the dustbag and filters. If a dustbag has not been inserted, the dust compartment cover will not close. Do not use force!

Unwind the cable completely to aid the vacuum in dissipating heat.

A temperature limiter automatically switches off the vacuum cleaner if it gets too hot, see "Frequently asked questions".

On the underside of the vacuum handpiece is a metal insert designed to absorb static electricity. Please make certain that your hand remains around this metal insert.

Do not leave the vacuum plugged in. Unplug it from the outlet when not in use and before servicing.

Do not place anything into the openings of the vacuum. Do not use if any openings are blocked; keep them free of dust, lint, hair, or anything that may reduce air flow.

This appliance is equipped with a power cord reel. Hold plug when rewinding onto cord reel. Do not allow plug to whip when rewinding.

Accessory use

To avoid the risk of injury when vacuuming with a Miele Electrobrush or Rechargeable battery brush do not touch the rotating roller.

Use only attachments specified by Miele. Do not use the blower to operate paint sprayers or similar devices that emit volatile or toxic vapors.

Monitor the dustbag change indicator and inspect all filters regularly. To ensure efficient suction, clean or replace them as necessary according to the operating instructions. To guarantee safety, only use genuine Miele dustbags, filters and accessories.

Miele vacuum cleaner bags are disposable and intended to be used only once. Do not attempt to reuse them.

Do not use the vacuum without an accessory attached. The rim could be damaged and injuries could result from sharp edges.

IMPORTANT SAFETY INSTRUCTIONS

FCC and Industry Canada information:

This device complies with part 15 of the FCC Rules. Operation is subject to the following two conditions: (1) This device may not cause harmful interference, and (2) this device must accept any interference received, including interference that may cause undesired operation.

 Warning: Changes or modifications to this unit not expressly approved by the party responsible for compliance could void the user's authority to operate the equipment.

Note:

This equipment has been tested and found to comply with the limits for a Class B digital device, pursuant to Part 15 of the FCC Rules. These limits are designed to provide reasonable protection against harmful interference when the equipment is operated in a residential installation. This equipment generates, uses and can radiate radio frequency energy, and if not installed and used in accordance with the instructions, may cause harmful interference to radio communications. However there is no guarantee that interference will not occur in a particular installation. If this equipment does cause harmful interference to radio or television reception, which can be determined by turning the equipment off and on, the user is encouraged to try to correct the interference by one or more of the following measures:

- Reorient or relocate the receiving antenna
- Increase the separation between the equipment and receiver.
- Connect the equipment into an outlet on a circuit different from that to which the receiver is connected.
- Consult the dealer or an experienced radio/TV technician for help.

IMPORTANT SAFETY INSTRUCTIONS

Maintenance and care

■ A damaged power cord must only be replaced with a genuine Miele cord by an authorized service agent.

■ Clean only with a dry or slightly damp cloth when disconnected from the power supply. Never submerge in water.

Repairs may only be performed by an authorized service agent in accordance with national and local safety regulations. Repairs by unqualified persons could be dangerous.

Disposal

■ Remove the battery from the radio handpiece and recycle it.

■ Before discarding an old vacuum cleaner, please cut off the power cord and render the plug useless. Ensure the appliance presents no danger to children while being stored for disposal.

SAVE THESE INSTRUCTIONS

CONSIGNES DE SÉCURITÉ IMPORTANTES

Lorsque vous utilisez un appareil électrique, vous devez toujours prendre des précautions essentielles, y compris ce qui suit:

LISEZ TOUTES LES INSTRUCTIONS AVANT D'UTILISER L'APPAREIL

Le fabricant n'est pas responsable des dommages causés par le non-respect des présentes instructions.

ATTENTION-

Afin de réduire le risque d'incendie, de choc électrique ou de blessures :

Avant l'utilisation

■ Vérifiez que l'emballage, l'aspirateur et les accessoires ne sont pas endommagés. N'utilisez pas un appareil endommagé. Un aspirateur endommagé peut être dangereux.

■ Vérifiez la tension nominale de l'aspirateur avant de le brancher. La tension électrique de votre résidence doit correspondre à celle indiquée sur la plaque signalétique située sous l'aspirateur. N'utilisez que des prises domestiques de courant alternatif. N'utilisez jamais de prise de courant continu. Si vous ne connaissez pas le type d'alimentation électrique de votre résidence, consultez un électricien qualifié. Si vous branchez votre appareil à une source d'alimentation électrique de tension supérieure à celle indiquée dans les présentes instructions, vous risquez d'endommager l'appareil ou de vous blesser.

■ La prise électrique doit être équipée d'un fusible de 15 ampères.

Utilisation

■ Cet aspirateur est destiné uniquement à l'usage domestique pour nettoyer les planchers **secs**. Ne l'utilisez pas pour nettoyer des personnes ou des animaux. D'autres utilisations, modifications et changements apportés à l'appareil seraient au risque du propriétaire et pourraient s'avérer dangereux. Le fabricant n'est pas responsable des dommages causés par le non-respect des présentes instructions.

Sécurité des enfants

■ Ne laissez pas de jeunes enfants jouer avec l'appareil ou le faire fonctionner.

CONSIGNES DE SÉCURITÉ IMPORTANTES

Utilisation

■ Débranchez l'aspirateur lorsque vous changez les accessoires, en particulier la brosse turbo et la brosse à batterie rechargeable.

■ Ne faites fonctionner l'aspirateur que si le sac à poussière, le filtre du compartiment à poussière et le filtre d'évacuation sont bien en place. Sinon, vous risquez de l'endommager.

■ Si vous n'avez pas inséré un sac à poussière, le couvercle du compartiment à poussière ne se refermera pas. Ne le forcez pas!

■ Une pièce métallique, destinée à absorber la charge électrostatique, est placée sous la poignée de l'aspirateur. Assurez-vous que votre main enveloppe bien cette pièce métallique lorsque vous utilisez l'appareil.

■ N'utilisez pas l'aspirateur pour aspirer des liquides ou des matières humides, ce qui provoquerait des défauts majeurs et pourrait nuire sérieusement au fonctionnement et à la sécurité électrique de l'appareil. Attendez que les tapis fraîchement lavés ou les revêtements de plancher soient complètement secs avant d'utiliser l'aspirateur.

■ N'utilisez pas l'aspirateur pour ramasser des matières brûlantes ou fumantes telles que cigarettes, allumettes ou cendres encore chaudes. L'aspirateur pourrait prendre feu.

■ N'utilisez pas l'aspirateur pour aspirer de l'encre en poudre. L'encre en poudre, comme celle utilisée pour les imprimantes et les photocopieurs peut être conductrice d'électricité. Le système de filtres de l'aspirateur risque de ne pas retenir toute la poudre d'encre qui serait alors rejetée dans l'air par le ventilateur.

■ N'utilisez pas l'aspirateur pour aspirer des liquides inflammables ou des matières explosives ou dans des lieux où de telles matières sont entreposées.

■ N'utilisez pas l'aspirateur pour ramasser des articles lourds, durs ou avec des bords tranchants ou pointus. Ils pourraient boucher et endommager l'appareil.

■ Veillez à ce que vos cheveux, vos vêtements, s'ils sont amples, vos doigts et toutes les autres extrémités de votre corps ne se trouvent pas à proximité des ouvertures et des parties motrices de l'appareil.

CONSIGNES DE SÉCURITÉ IMPORTANTES

■ Ne tirez pas sur le cordon d'alimentation pour transporter l'appareil, n'utilisez pas le cordon d'alimentation comme poignée, ne fermez pas de porte sur le cordon d'alimentation et ne le passez pas sur des rebords ou des coins tranchants. Ne faites pas rouler l'appareil sur le cordon d'alimentation. N'utilisez pas l'appareil s'il est endommagé.

■ Surveillez le voyant de remplacement du sac à poussière et vérifiez tous les filtres régulièrement. Pour de meilleurs résultats, il faut remplacer le sac à poussière et les filtres lorsque c'est nécessaire. Un sac plein ou un filtre obstrué réduira la puissance de succion de l'aspirateur. Un limiteur de température éteint automatiquement l'appareil en cas de surchauffe; consultez la section « Questions fréquentes ».

Utilisation des accessoires

■ Pour éviter les risques de blessures lorsque vous nettoyez avec l'électrobrosse ou la brosse à batterie rechargeable Miele, ne touchez pas à la brosse rotative. Vous pourriez vous blesser.

■ Il n'est pas recommandé d'utiliser l'aspirateur avec le tube seul, c'est-à-dire sans avoir raccordé un accessoire, car vous pourriez en endommager le rebord et vous blesser au contact des bords coupants.

■ Les sacs à poussière Miele sont jetables et conçus pour être utilisés une seule fois. Ne les réutilisez pas. Un sac trop rempli réduira l'efficacité de l'aspirateur.

■ Utilisez uniquement les sacs à poussière d'origine Miele portant le sceau de qualité Miele et les filtres et accessoires d'origine Miele! Ce n'est qu'à cette condition que le fabricant peut vous garantir la sécurité de l'appareil.

CONSIGNES DE SÉCURITÉ IMPORTANTES

FCC and Industry Canada information:

This device complies with part 15 of the FCC Rules. Operation is subject to the following two conditions: (1) This device may not cause harmful interference, and (2) this device must accept any interference received, including interference that may cause undesired operation.

 Warning: Changes or modifications to this unit not expressly approved by the party responsible for compliance could void the user's authority to operate the equipment.

Note:

This equipment has been tested and found to comply with the limits for a Class B digital device, pursuant to Part 15 of the FCC Rules. These limits are designed to provide reasonable protection against harmful interference when the equipment is operated in a residential installation. This equipment generates, uses and can radiate radio frequency energy, and if not installed and used in accordance with the instructions, may cause harmful interference to radio communications. However there is no guarantee that interference will not occur in a particular installation. If this equipment does cause harmful interference to radio or television reception, which can be determined by turning the equipment off and on, the user is encouraged to try to correct the interference by one or more of the following measures:

- Reorient or relocate the receiving antenna
- Increase the separation between the equipment and receiver.
- Connect the equipment into an outlet on a circuit different from that to which the receiver is connected.
- Consult the dealer or an experienced radio/TV technician for help.

CONSIGNES DE SÉCURITÉ IMPORTANTES

Entretien

■ Mettez l'interrupteur de l'aspirateur en position arrêt après chaque utilisation et avant de procéder à son entretien. Débranchez-le.

■ Ne l'immergez jamais dans l'eau. Nettoyez-le seulement avec un linge sec ou légèrement humide lorsqu'il est débranché. Si de l'humidité pénètre dans l'appareil, il y a un risque de choc électrique.

■ Les réparations doivent être effectuées uniquement par un technicien autorisé conformément aux codes et règlements locaux. Des réparations effectuées par des personnes non-qualifiées pourraient être dangereuses.

■ Si le cordon d'alimentation est endommagé, il faut le remplacer ainsi que l'enrouleur.

Mise au rebut

■ Enlevez la pile qui alimente le bouton de contrôle de la poignée et la recycler.

■ Avant de jeter un vieil aspirateur, coupez le cordon d'alimentation et rendez la fiche inutilisable. Veillez à ce que l'appareil ne présente aucun danger pour les enfants pendant son entreposage pour mise au rebut.

Le fabricant n'est pas responsable des dommages causés par le non-respect des présentes consignes de sécurité.

**VEUILLEZ
CONSERVER CES
INSTRUCTIONS**

Guide to the machine

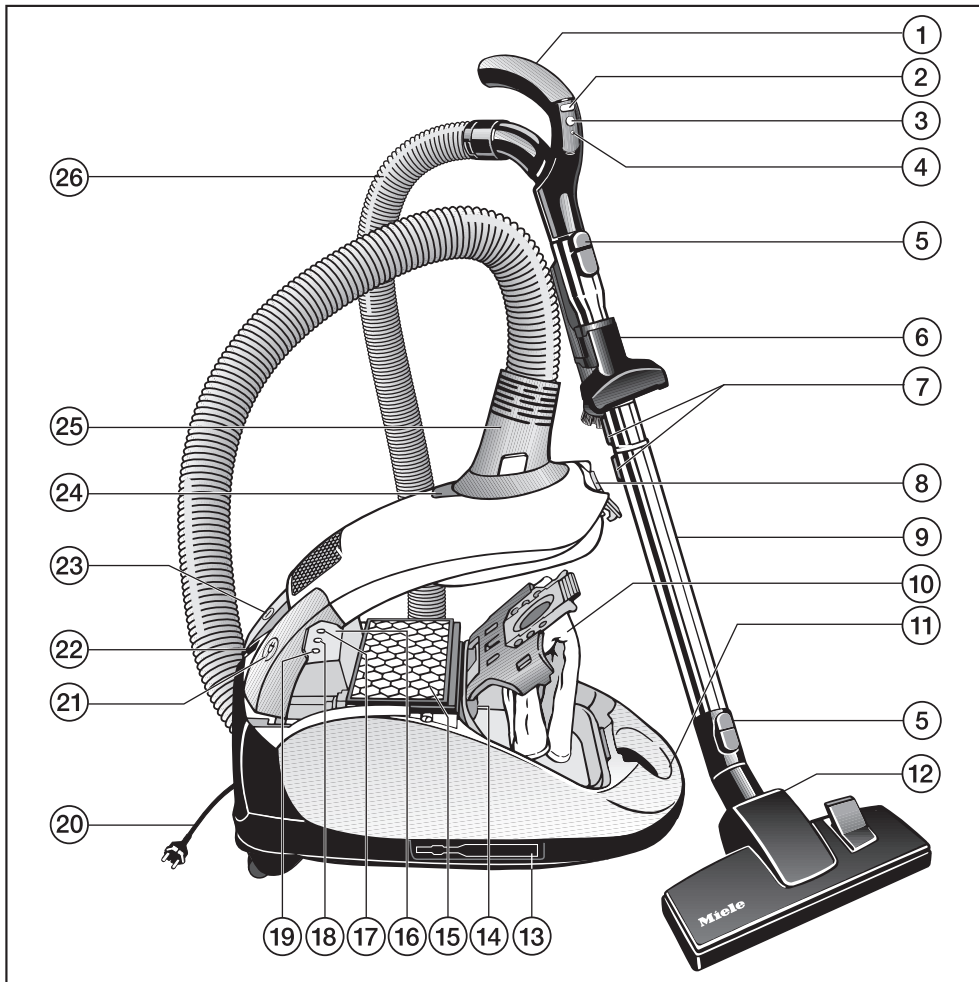

Some models come standard with one of the following accessories, which are not shown in this figure.

- Floor tool ALLERGOTEC
- Turbobrush
- Rechargeable battery brush ACCU NOVA

A separate Operating manual of the respective accessory is supplied with the vacuum.

- ① Handpiece (some models may include an air inlet valve) *
- ② Suction power buttons + / - *
- ③ Standby switch *
- ④ LED *
- ⑤ Locking button
- ⑥ Accessory clip *
- ⑦ Telescopic wand release button *
- ⑧ Dust compartment lid release
- ⑨ Telescopic wand *
- ⑩ Dust bag
- ⑪ Carrying handle
- ⑫ Floor tool *
- ⑬ Transport/storage holder
- ⑭ Dust compartment filter (motor protection)
- ⑮ Exhaust filter *
- ⑯ Suction power selector *
- ⑰ Standby indicator *
- ⑱ Thermo indicator  *
- ⑲ Exhaust filter change indicator (Reset button) *
- ⑳ Power cord with plug
- ㉑ Cord rewind switch
- ㉒ Park-System
- ㉓ On / Off switch
- ㉔ Dustbag change indicator
- ㉕ Elbow
- ㉖ Suction hose

The features marked * may vary or not be available depending on your model.

Before using the vacuum cleaner

Attaching the suction hose

- Insert the elbow into the suction socket until it clicks. Use the inlet guides to direct insertion.

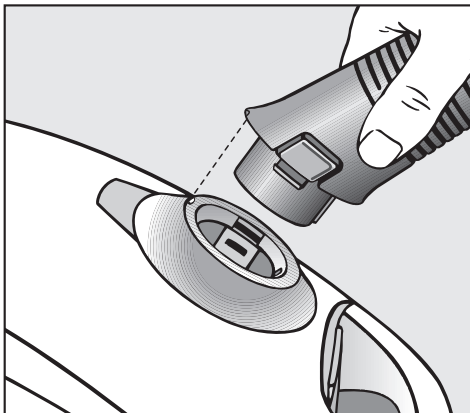

Removing the suction hose

- Press the release buttons at the sides of the elbow and lift the hose from the socket.

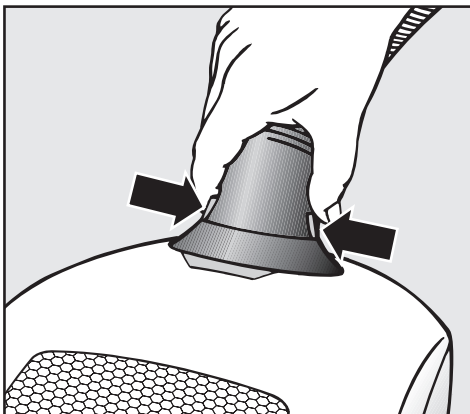

Connecting the handpiece and telescopic wand

- Insert the handpiece into the telescopic wand until it clicks. Use the inlet guides to direct insertion.
- To release the handpiece from the telescopic wand press the locking button (see arrow) and pull the handpiece away from the telescopic wand.

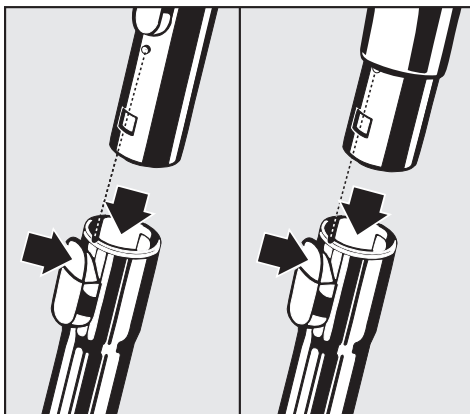

Before using the vacuum cleaner

Depending on your model, the vacuum will include one of the following telescopic wands:

- 2-piece wand
- Telescopic wand
- XXL telescopic wand

Inserting the 2-piece wand

Both sections of the 2-piece wand have locating arrows. When connecting the two tubes, ensure that the two arrows point to each other.

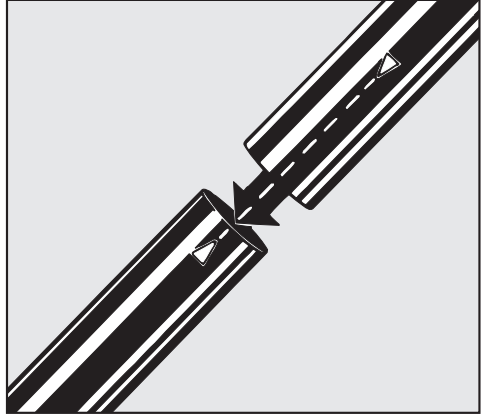

Adjusting the telescopic wand

One section of the telescopic wand is inside the other and can be adjusted for comfortable vacuuming.

- Press the telescopic wand release button (see arrow) to release the tubes and adjust to the desired height.

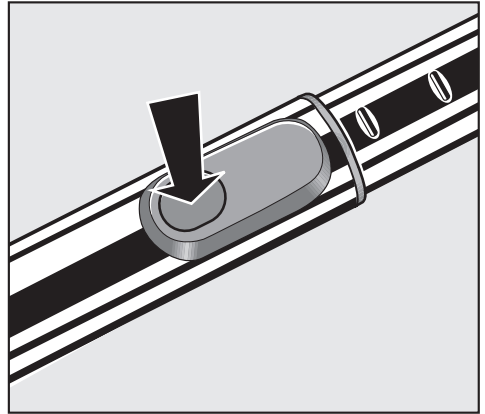

Adjusting the XXL telescopic wand

This telescopic wand consists of three sections which are height-adjustable.

- Pull and extend the lower section of the wand, ①, until it clicks. Press the release button if you want to retract the lower section again.
- Press the adjustment button, ②, to release the tubes and adjust to the desired height.

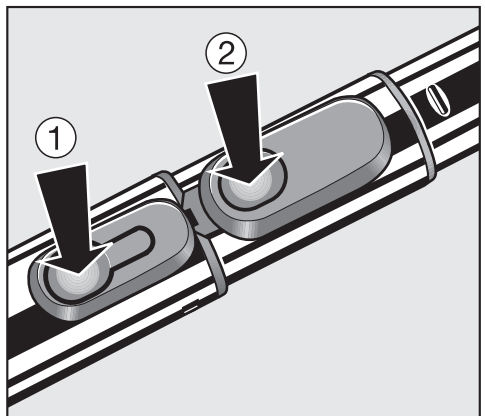

Before using the vacuum cleaner

Attaching the floor brush

- Insert the telescopic wand into the floor brush and twist until it locks with a click.
- To release the floor brush from the telescopic wand, press the locking button (see arrow) and pull the wand out of the floor brush.

The floor brush is suitable for cleaning carpets, rugs, and hard surfaces. For flooring susceptible to scratches, use one of the special Miele floor brushes (see "Optional accessories").

Observe the cleaning instructions of the floor manufacturer.

To clean carpets and area rugs:

- Press the foot switch marked .

To clean hard flooring:

- Press the foot switch marked .

Floor tool ALLERGOTEC / Turbobrush / Rechargeable battery brush ACCU NOVA

Single models come standard with one of these accessories (see "Optional accessories"). Please refer to the separate operating instructions supplied with these brushes for instructions on use and maintenance.

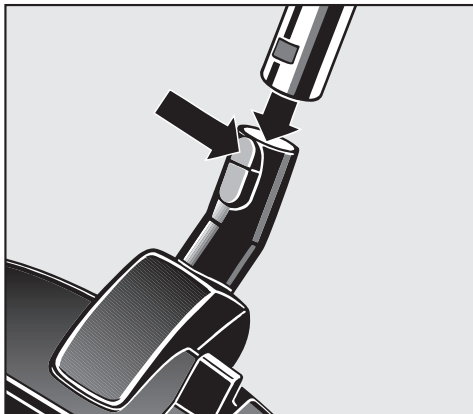

Using the included accessories

The following accessories are included:

- ① Crevice nozzle
- ② Dusting brush (depending on model)
- ③ Upholstery tool
- ④ Accessory clip for the respective included accessories
- ⑤ Filter frame

The filter frame is supplied only with those models which are fitted with an "ActiveAirClean Plus" or "Active HEPA Plus" exhaust filter as standard. The filter frame is required to replace one of these filters with a "SUPER air clean" filter (see "Maintenance and care - Replacing one type of filter with another").

Accessory clip

- The accessory clip can be attached to the handpiece.

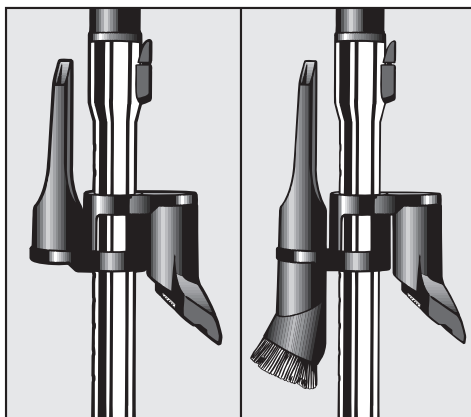
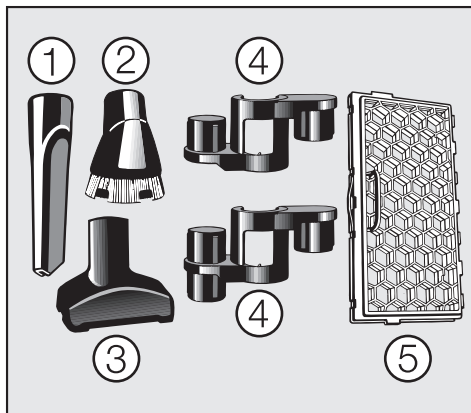

Standard floor brush

The standard floor brush can be used for normal cleaning of carpets, rugs, hard surfaces, carpeted stairs, etc.

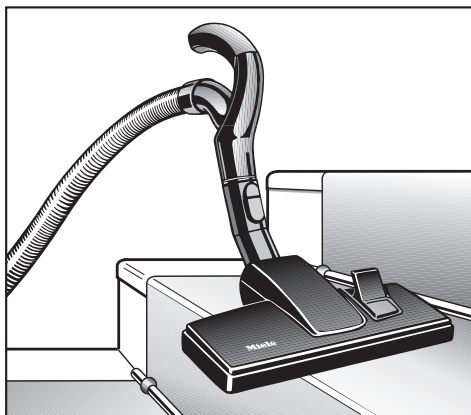

Using the included accessories

Crevice nozzle

For cleaning in folds, crevices and corners.

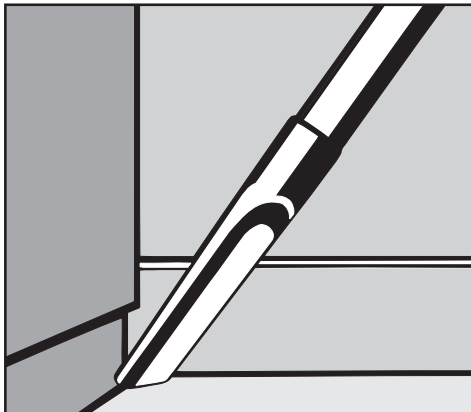

Upholstery nozzle

For cleaning upholstery, mattresses, cushions, curtains, covers, etc.



Dusting brush

(select models)

For cleaning moldings, decorative or carved items, etc.

The head of the dusting brush can be swivelled to attain the best cleaning position.

Dust brush with natural bristles

(select models)

For dusting particularly delicate objects.

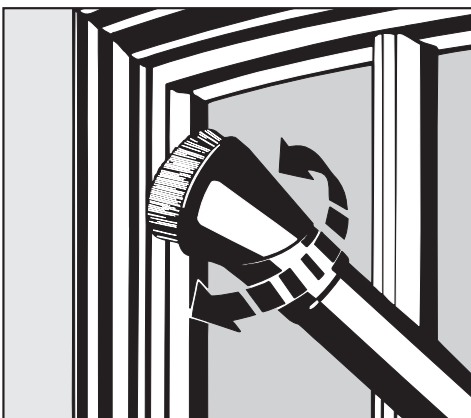

Power cord

 If the vacuum cleaner is operated for more than 30 minutes the power cord must be unwound at least $\frac{2}{3}$ of the way. Danger of overheating!

Unwinding

- Hold the plug and pull the power cord out to the required length (maximum 18 ft / 5.5 m).

 To reduce the risk of electric shock, the vacuum has a polarized plug (one blade is wider than the other). This plug will fit in a polarized outlet only one way. If the plug does not fit fully in the outlet, reverse the plug. If it still does not fit, contact a qualified electrician. Do not alter the plug in any way. Danger of overheating and damage.

Rewinding

- Unplug the vacuum from the outlet.
- Press the rewind switch briefly and the power cord will rewind automatically.
- Press the rewind switch again to stop the rewinding.
- Hold the plug so that it does not whip around when rewinding.

Turning the vacuum on and off

- Press the On/Off switch.

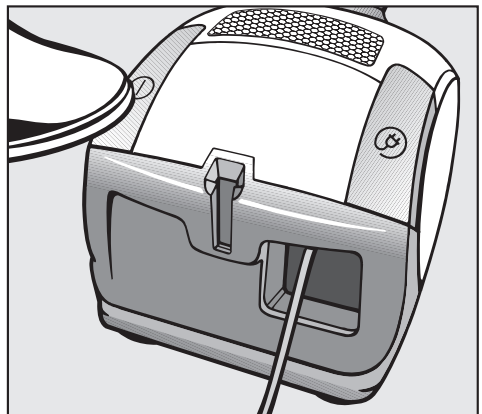
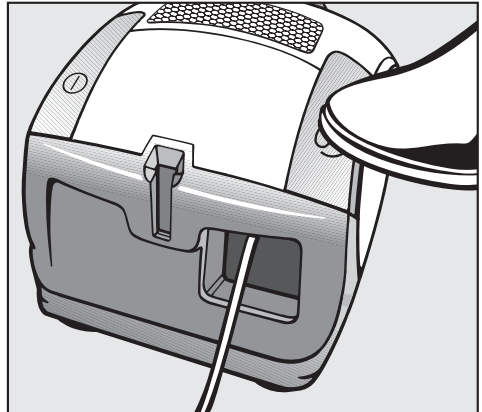
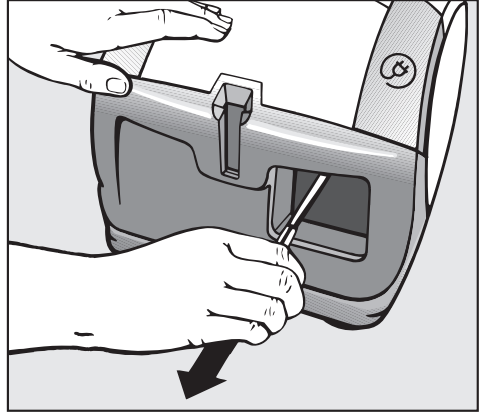

Operation

Models with radio frequency controls

The operating state is shown by the Standby indicator on the vacuum.

The vacuum can be switched to a standby mode during pauses.

- Press the Standby button on the radio handpiece.

When the button is pressed again, the vacuum will turn on to the last selected power level.

Every push of a button at the radio handpiece is displayed by the indicator light.

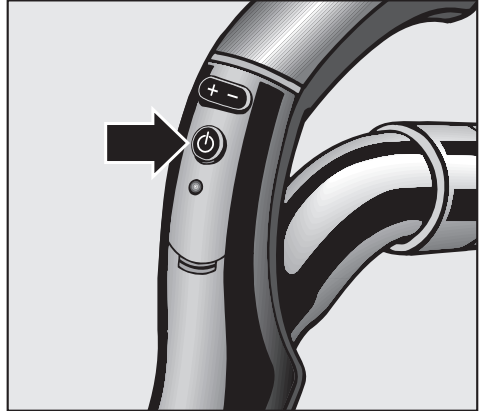







While vacuuming

The vacuum cleaner can also stand on its end for vacuuming stairs, drapes etc.

 To prevent static electricity your hand must touch the metal inlay on the underside of the vacuum handpiece. Be certain to continuously touch this inlay when vacuuming fine dust, flour or sawdust as these materials are more likely to create a static discharge. To further prevent static discharge while vacuuming, pull the vacuum along by the hose with one hand while continuing to hold the handpiece in the other hand.

Adjusting the suction

The symbols on the controls indicate what each setting is suitable for.

-  curtains, lightweight fabrics
-  upholstery, cushions
-  thick pile carpets, rugs and runners
-  energy-saving, daily use
-  lightly soiled textured carpets
-  textured hard flooring, and intensive cleaning of carpets

Operation

The controls vary from model to model, and are described as follows.

Rotary selector

- Turn the rotary selector to the desired suction power setting.

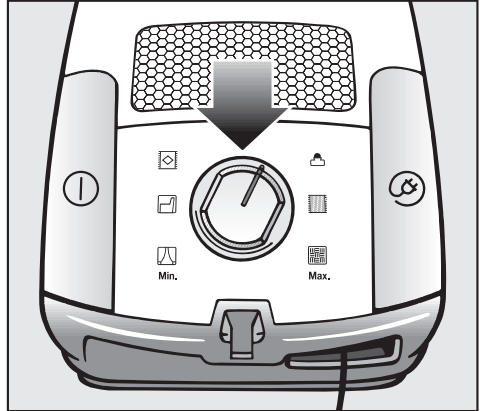

+ / – controls

Press the controls until the light bar above the desired suction power setting is illuminated.

- Press the + control to select a higher setting.
- Press the – control to select a lower setting.

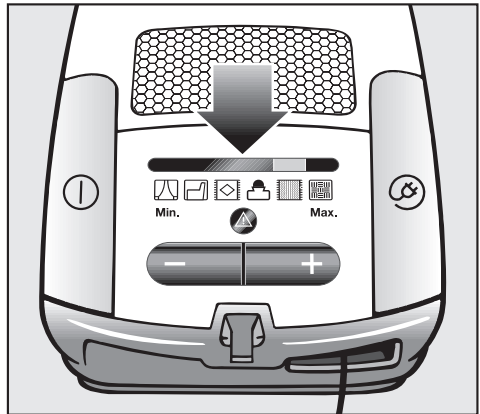

+ / – at the radio handpiece

Press the controls until the desired suction power is shown in the vacuum display.

- Press the + control to select a higher setting.
- Press the – control to select a lower setting.

Every push of a button at the radio handpiece is displayed by the indicator light.

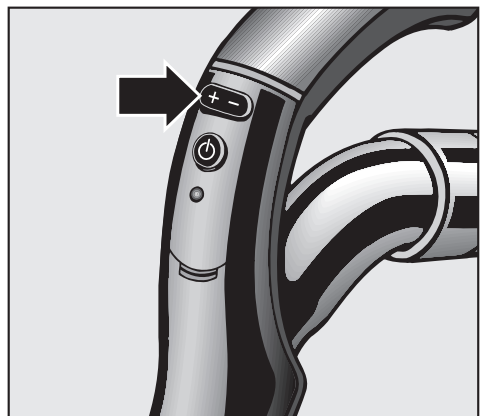

Opening the air inlet valve

(not available in models with radio handpiece)

The air inlet valve is designed to provide a quick, convenient reduction of suction power, e.g. when moving from a carpet to an area rug.

- Open the air inlet valve far enough to reduce the power.

Opening the air inlet valve reduces the power to the tool being used.

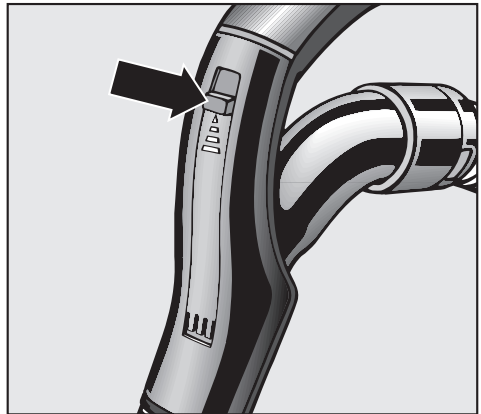
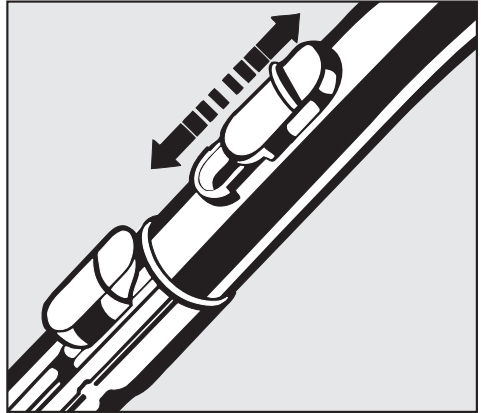

Transport and storage

Park-System

A Park-System has been designed to conveniently park the telescopic wand at the vacuum cleaner during pauses.

- A special parking attachment is fitted to all floor brushes. Insert the lower clip of the floor brush into the slot on the end of the vacuum cleaner from above.

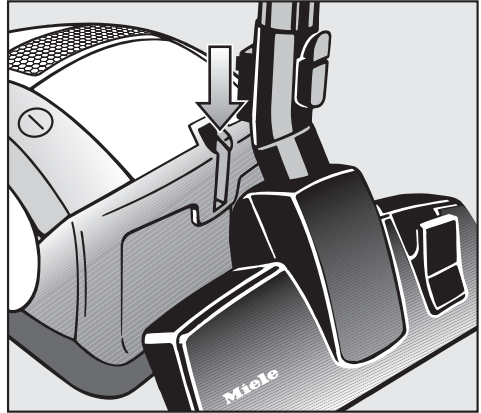

Transport and storage

- For easier transportation and storage stand the vacuum cleaner vertically.
- Insert both clips of the floor brush into the two point holder on the side of the vacuum.

This makes the vacuum easy to carry and store.

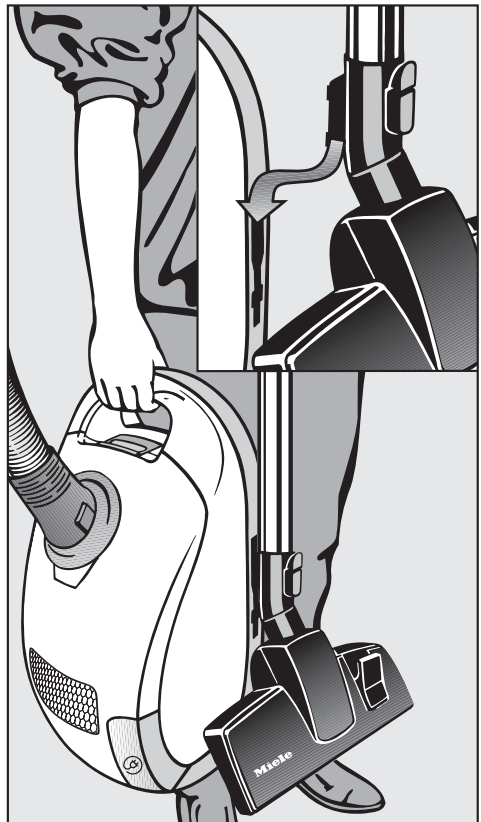

 Turn off the vacuum and unplug it from the outlet before performing any maintenance work.

The Miele filter system consists of three filters which must be replaced from time to time to ensure efficient suction.

- Dustbag
- Exhaust filter
- Dust compartment filter (motor protection)

Use only Miele dustbags with the Miele quality signet and original Miele filter. This ensures optimum performance of the suction power and also ensures that the bag is used to capacity.

The use of non-Miele dustbags could cause damage to the vacuum cleaner.

Purchasing new dustbags and filters

Replacement dustbags and filters can be purchased from your local Miele Dealer.

Which dustbags and filters are the right ones?

Order original Miele dustbags with the letters **F/J/M**.

A "SUPER air clean" exhaust filter and a dust compartment filter are supplied with every box of Miele dustbags. If you wish to purchase exhaust filters or dust compartment filters separately, please quote the model number on the data plate located underneath the appliance.

You can replace the exhaust filter supplied with the vacuum cleaner with one of the other types of filters (see "Optional accessories").

Maintenance and care

When to change the dustbag

Change the dustbag when the colored marker in the dustbag change indicator fills the display.

The dust bags are disposable and intended to be used only once. Do not attempt to reuse.

Checking the dustbag change indicator

- Attach the floor brush to the vacuum cleaner.
(Perform this test with the floor brush only, since other attachments can affect the function of the dustbag change indicator.)
- Turn the vacuum cleaner on and select the highest power setting.
- Lift the floor brush slightly off the floor. If the marker completely fills the indicator window, the dust bag needs to be changed.

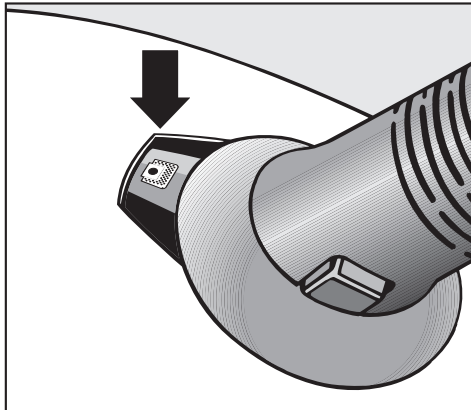

How the dustbag change indicator works

The dustbag change indicator is designed to show when the bag is full of common household dust and to measure the amount of air flow through the dustbag. Normal household dust is a mixture of dust, hair, carpet fluff, threads, sand, etc.

However, if fine dust, such as drill dust, sand, plaster or flour is vacuumed, the pores of the dustbag will become blocked. The marker will indicate that the bag is "full" even when it is not. The dustbag should be changed because the suction power is greatly reduced.

If the bag is bulging with pet fur, hair, carpet fluff, etc., the indicator may not register "full". This is because the air flow of the dustbag may still be high enough not to activate the marker to show maximum. The dustbag should still be changed.

Replacing the dustbag

- Open the dust compartment lid.

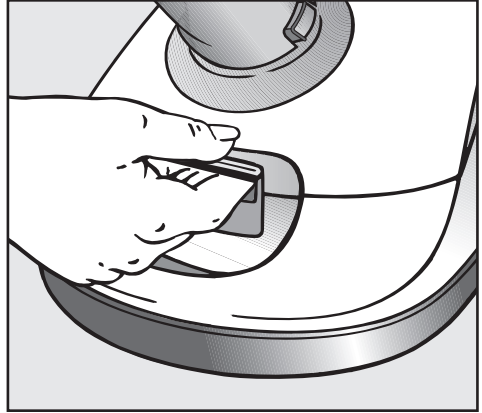

- Grasp the collar by the two finger holes and pull it out of the dustbag holder.

The dustbag has a flap which closes automatically to prevent dust from escaping when it is removed.

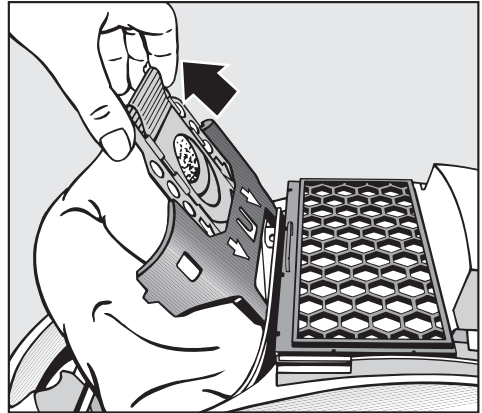

- Insert the new dust bag as far as it will go into the dustbag holder. Do not unfold the dustbag when taking it out of the box. Keeping it folded will prevent it from getting caught when the dust compartment lid is closed.

- Close the dust compartment lid until it clicks into place. Take care not to catch the dust bag in the lid.

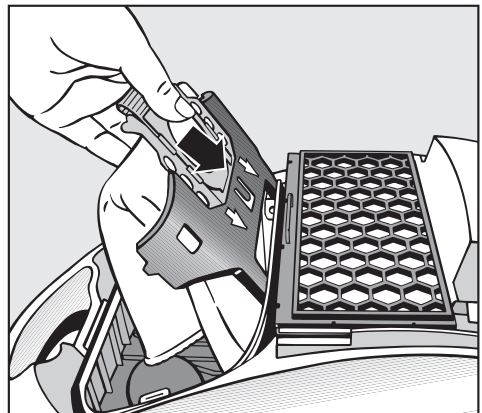

 A empty-operation-barrier will block the dust compartment lid from closing if no dustbag is inserted or if it is not inserted all the way. Do Not Use Force!

Maintenance and care

Replacing the exhaust filter

Depending on model, the vacuum cleaner will be equipped with one of the following exhaust filters:

- a** SUPER air clean filter
- b** ActiveAirClean Plus filter
- c** Active HEPA Plus filter

"SUPER air clean" filter

A "SUPER air clean" filter is supplied with every box of Miele dustbags. It should be replaced each time a new box of bags is started.

"ActiveAirClean Plus" or the "Active HEPA Plus" filter

An "ActiveAirClean Plus" or "Active HEPA Plus" filter should be changed approximately once a year. Change the filter sooner if it is obviously soiled or no longer effective.

It is helpful to note the date directly on the filter as a reminder for when to next change it. See "Optional Accessories" for filter descriptions.

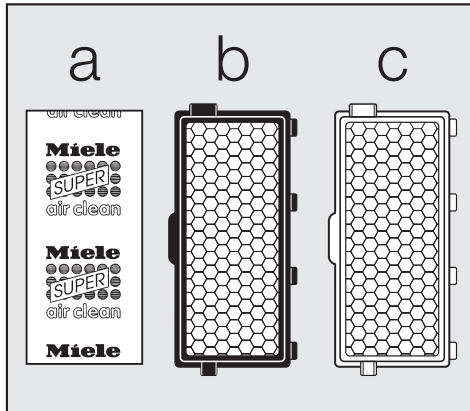

Exhaust filter change indicator

Some models are equipped with an exhaust filter change indicator (Reset button) which is designed to alert the user when to change the "ActiveAirClean Plus" or "Active HEPA Plus" filter.

The indicator will light after about 50 hours of operation which is equivalent to about a year of average use. The vacuum cleaner can still be used with the exhaust filter indicator lit. However, the suction power will be reduced as will the effectiveness of the filter if it is not replaced.

If a SUPER air clean filter, **a**, is being used, the filter change indicator can be disregarded but should be reset when it does light. The indicator goes out when the reset button is pressed.

You can replace the exhaust filter supplied with the vacuum cleaner with one of the other types of filters (see "Optional accessories").



Maintenance and care

Replacing the "SUPER air clean" filter

- Open the dust compartment lid.
- Open the filter frame and remove the used "SUPER air clean" filter with the clean corner (see arrow).

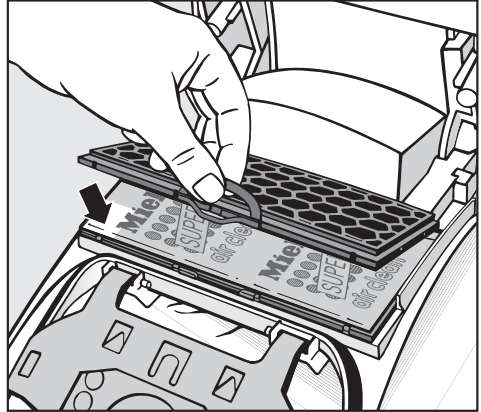

- Insert the new filter.
- Close the filter frame.
- Close the dust compartment lid firmly until it clicks into place.

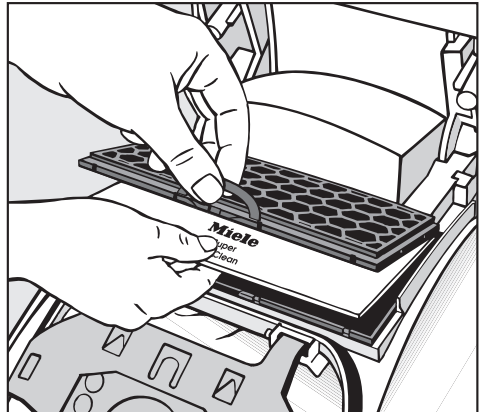

Replacing the "ActiveAirClean Plus" filter and the "Active HEPA Plus" filter

- Open the dust compartment lid.
- Remove the exhaust filter.

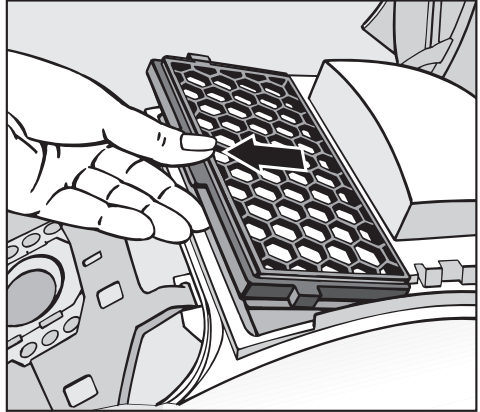

- Insert the new filter.
- Close the dust compartment lid firmly until it clicks into place.

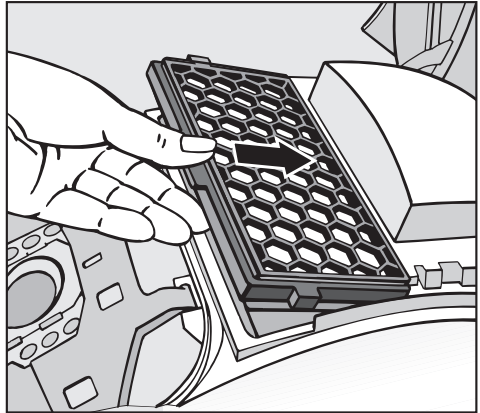

Resetting the filter change indicator

The filter change indicator (Reset button) must be reset each time the filter is replaced. To do this, the vacuum cleaner must be plugged in.

- Press and hold the filter change indicator light until it goes out.

The display is now reset.



Maintenance and care

Replacing one type of filter with another

1. If you wish to replace the **a** SUPER air clean filter with the **b** ActiveAirClean Plus filter or the **c** Active HEPA Plus filter, you must remove the filter frame before inserting the new filter.

2. If you use SUPER air clean filter **a** you must insert it into the filter frame.

* Filter frame - see "Using the included accessories".

The ActiveAirClean Plus filter can be used instead of the Active HEPA Plus filter and vice versa without any changes.

Remember to reset the filter change indicator with the Reset button after every filter change. The indicator will go out when the reset button is pressed.

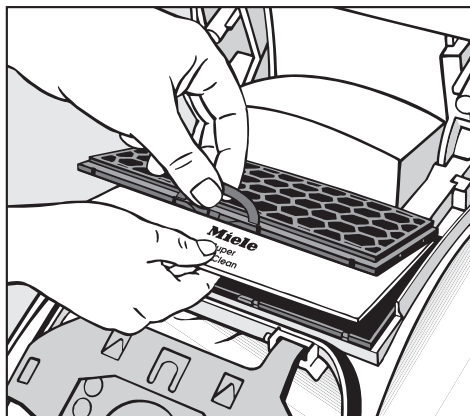
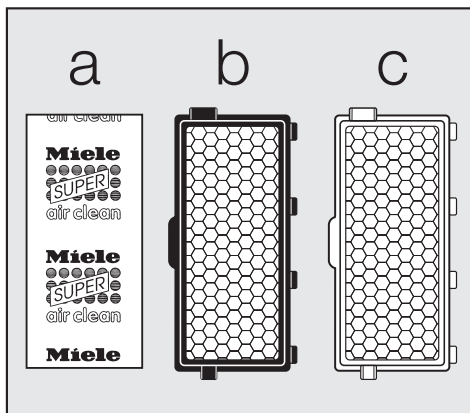

Reset



When to change the dust compartment filter (motor protection)

Replace the dust compartment filter every time you start a new box of dustbags. A dust compartment filter is supplied with each box of Miele dustbags.

Replacing the dust compartment filter (motor protection)

- Open the dust compartment lid.
- Open the filter frame, remove the old filter and replace with a new one.
- Close the filter frame.

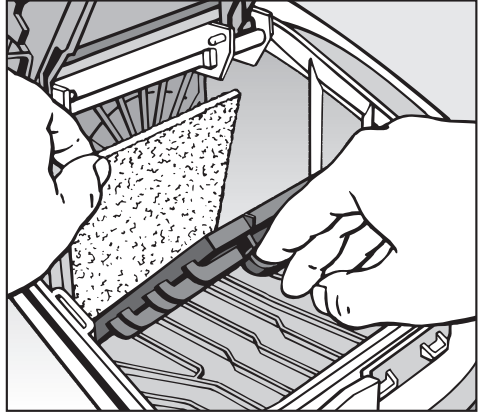

When to change the radio handpiece battery

Every 18 months

Keep a 3 V lithium battery handy.

The vacuum can still be used if the battery is weak or not inserted at all. The vacuum will operate continuously on the maximum suction power.

How to change the radio handpiece battery

- Lift the battery compartment lid and take the old battery out. Please recycle.
- Replace the battery with a new one. Pay attention to the polarity.
- Close the battery compartment.

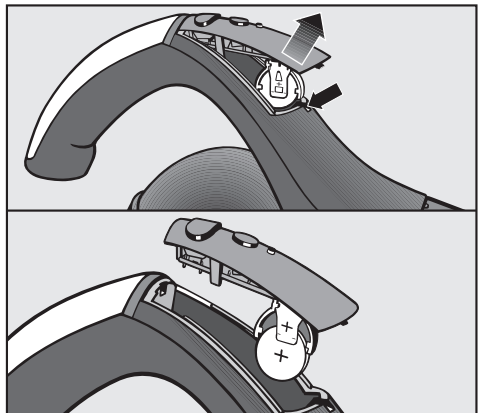

Maintenance and care

When to change the thread catcher pads

The thread catcher pads on the bottom of the floor tool and the upholstery tool should be checked occasionally.

Replace the pads if they appear worn.

Replace them if the pile is worn.

Replacing the thread catchers

- Use a knife or similar object to remove the thread catchers from the slots.
- Insert the new thread catchers.

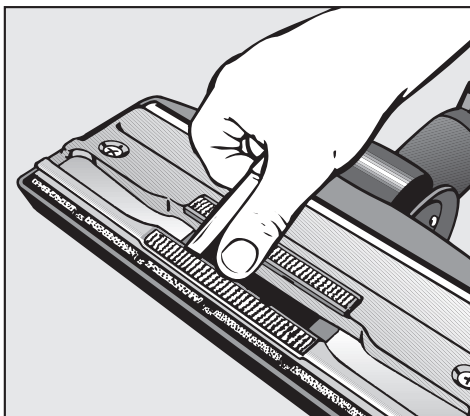

Servicing the floor roller

- Use a coin to release the roller pin and take it out, ①.
- Push and take out the roller axle, ②.
- Take out the roller, ③.
- Remove all threads, hair, etc. and reassemble the parts in the reverse order.

Spare parts are available from your Miele dealer or from the Miele.

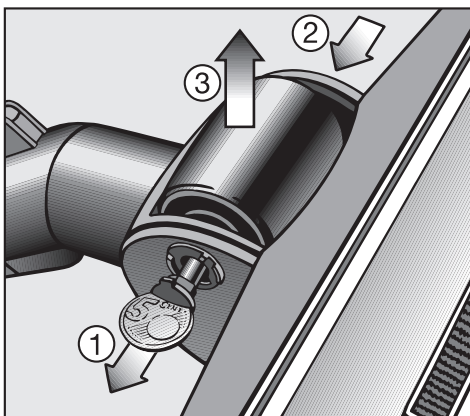

 Turn off the vacuum and unplug it before performing any maintenance work.

Vacuum cleaner and accessories

External surfaces of the vacuum cleaner and accessories can be cleaned with a slightly damp cloth or with a cleaner suitable for plastics.

 Do not use abrasive, glass or all purpose cleaners! They will damage the surface.

Dust compartment

The dust compartment can, if necessary, be cleaned using a **dry** cloth, dusting brush or a second vacuum to suck out any dust. Monitor the change dustbag indicator and inspect all filters regularly. Clean or replace them when necessary according to these Operating Instructions.

 Do not submerge the vacuum in water! If moisture gets into the appliance there is the risk of an electric shock.

Frequently asked questions

Some models have a warning light  which comes on to indicate overheating.

If the vacuum has overheated the temperature limiter automatically turns the vacuum off. Some models also have a warning light  to indicate that the vacuum has overheated.

This can occur if, for instance, large articles block the suction tube or when the filter bag is full or contains particles of fine dust. A heavily soiled exhaust or dust compartment filter can also be the cause of overheating. Turn off the vacuum cleaner using the On/Off switch.

Unwind the full length of the power cord. Allow the vacuum to cool down for 30 minutes.

After sales service

In the event of a problem that you can not fix yourself, please contact

- Your Miele Dealer or
- The Miele Service Department

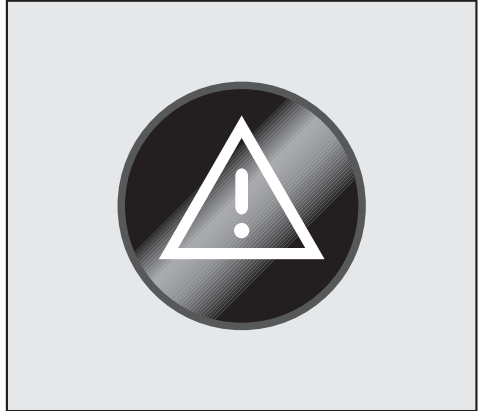

Each model comes standard with one or several of the following tools.

Rechargeable battery brush

The rechargeable battery brush is intended for intensive cleaning and restoring of thick pile carpeting. It is particularly suitable for cleaning and restoring crushed carpet pile of floor coverings subject to hard wear, especially in high traffic areas.

Observe the cleaning instructions of the floor manufacturer.



Turbobrush

The Turbobrush is intended for cleaning short to medium pile carpeting. It is mechanically driven by the suction power of the vacuum. In addition to dust particles it also removes stubbornly adhered threads, hairs, fluff, etc.

Observe the cleaning instructions of the floor manufacturer.



Hand Turbobrush

The Hand Turbobrush is intended for vacuuming upholstery, mattresses, car seats, carpeted stairs and other areas inaccessible with the standard Turbobrush.

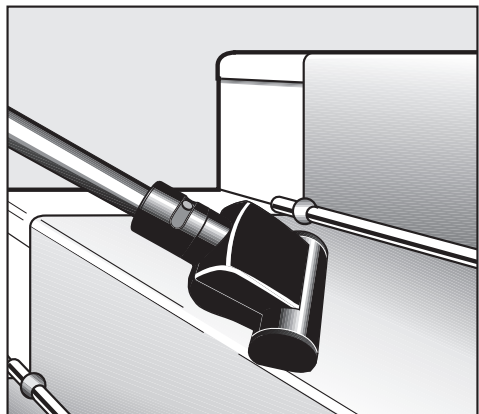

Optional accessories

Floor tool ALLERGOTEC

The level of cleanliness is visible by a color display (traffic light colors) during vacuuming. It is especially adequate for the daily hygienic vacuuming of all flooring types.

Observe the cleaning instructions of the floor manufacturer.



Hard floor brush

To vacuum sturdy hard floors, e.g. tiles and stone floors.



Parquet floor brush

Special brush with natural bristles intended for cleaning parquet and laminate floors, especially those susceptible to scratching.



Universal brush

For dusting books, shelves, etc.



Dusting brush

For cleaning moldings, decorative or carved items, etc.

Dust brush with natural bristles

For dusting particularly delicate objects.

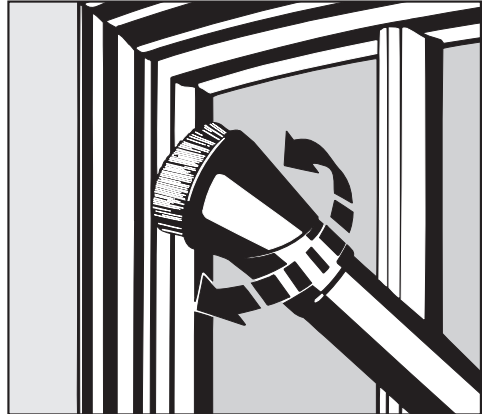

Radiator brush

(only usable with the crevice nozzle)

For cleaning radiators, narrow shelves or crevices.

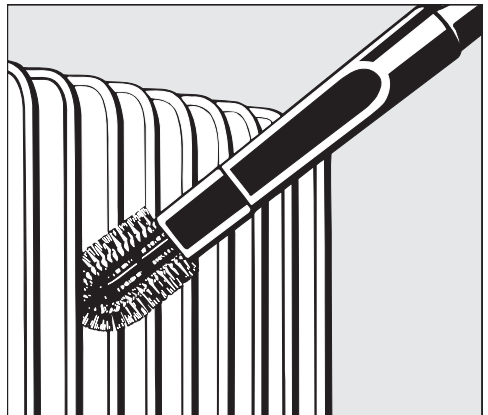

Optional accessories

Mattress tool

For cleaning deep crevices, mattresses and upholstery.



Crevice nozzle 12" (300 mm)

For cleaning in folds, crevices, corners, etc.

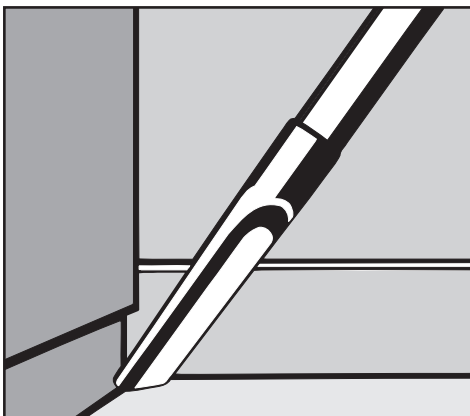

MicroSet

This set is specially designed for cleaning small objects and difficult to reach areas (such as PC keyboards, stereo equipment, carved furniture and ornaments, models, etc).

Accessory set consists of:

- Micro hose with combi nozzle (crevice nozzle and dust brush)
- Micro dust brush
- Micro crevice nozzle
- Extension

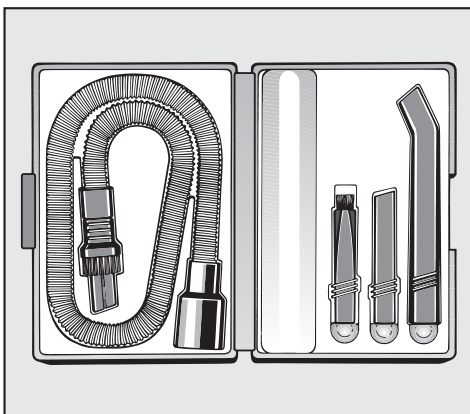

ActiveAirClean Plus filter

A special active charcoal filter which absorbs odors from the dust collected in the dustbag. The "ActiveAirClean Plus" filter can be used in place of the "SUPER air clean" filter. There is no difference in the fine dust performance of the "ActiveAirClean Plus" and the "SUPER air clean" filter.

Active HEPA Plus Filter

The "Active HEPA Plus" filter combines activated charcoal and HEPA filtration in one. The active charcoal layer absorbs odors from the dust collected in the dustbag. Vacuum cleaners equipped with this exhaust filter are particularly suitable for allergy sufferers and those concerned with a high level of hygiene because of its ability to trap respirable particles and allergens.

Caring for the environment

Disposal of the packing materials

The cardboard box and packing materials protect the appliance during shipping. They have been designed to be biodegradable and recyclable.

Ensure that any plastic wrappings, bags, etc. are disposed of safely and kept out of the reach of children. These items pose a danger of suffocation.

Disposing of the dustbag and filters

Genuine Miele dustbags and filters are made of environmentally friendly materials. They can be thrown out with the household trash provided the vacuum has been used only for normal household dust.

When contacting the Technical Service,
please quote the model and serial number
of your appliance.

The Miele logo is displayed in a bold, white, serif font against a solid black rectangular background.

Miele, Inc. (USA)

National Headquarters

9 Independence Way
Princeton, NJ 08540
Phone: 800-843-7231
609-419-9898
Fax: 609-419-4298
www.mieleusa.com

Technical Service & Support

Nationwide

Phone: 800-999-1360
Fax: 888-586-8056

Miele Limited (CDN)

National Headquarters

55G East Beaver Creek Road
Richmond Hill, ON L4B 1E5
Phone: 800-643-5381
905-707-1171
Fax: 905-707-0177
www.miele.ca
info@miele.ca (general enquiries)
professional@miele.ca (commercial enquiries)

Mielecare National Service

Phone: 800-565-6435
905-850-7456
Fax: 905-850-6651
service@miele.ca (Tech. Service)