

## FCC COMPLIANCE REPORT

**Test report No** : EMC-2013/066  
**Type of Equipment** : Remote Keyless Entry System (Receiver)  
**Model Name** : SVI-KORX433  
**Applicant** : Continental Automotive Systems Corporation  
29, Siemens-Road, Icheon-City,  
Gyeonggi-Do, 467-080, Korea  
**Manufacturer** : Continental Automotive Systems Corporation  
29, Siemens-Road, Icheon-City,  
Gyeonggi-Do, 467-080, Korea  
**Test standards** : FCC part 15 subpart B, Class B  
RSS-Gen Issue 3: 2010  
**FCC ID** : SY5KORX433  
**Test Procedure and Items**  
- Radiated Emissions Measurement : ANSI C63.4-2009  
**Testing Laboratory** : EMC Compliance Ltd.  
**Test result** : Complied

The above equipment was tested by EMC compliance Testing Laboratory for compliance with the requirements of FCC Rules and Regulations. The results of testing in this report apply to the product/system which was tested only. Other similar equipment will not necessarily produce the same results due to production tolerance and measurement uncertainties.

These results are deemed satisfactory evidence of compliance with ICES-003 of the Canadian Interference-Causing Equipment Regulations.

Date of receipt: 2012. 12. 17

Date of testing: 2013. 01. 04

Issued date: 2013. 01. 10

**Tested by:**



AHN, BYUNG-WOO

**Approved by:**



YEOM, HAN-SEOK

## Contents

<b>1. Applicant information .....</b>	<b>3</b>
<b>2. Laboratory information .....</b>	<b>4</b>
<b>3. Test system configuration.....</b>	<b>5</b>
3.1 Operation environment .....	5
3.2 Measurement Uncertainty .....	6
<b>4. Description of E.U.T. ....</b>	<b>7</b>
4.1 General information .....	7
4.2 Product description .....	7
4.3 Auxiliary equipments .....	7
4.4 Test configuration .....	8
4.5 Operating conditions .....	8
<b>5. Summary of test results .....</b>	<b>9</b>
5.1 Summary of EMI emission test results .....	9
<b>6. Test results .....</b>	<b>10</b>
6.1 Radiated Emission .....	10
<b>7. E.U.T. photographs .....</b>	<b>14</b>

## 1. Applicant information

**Applicant:** Continental Automotive Systems Corporation  
**Address:** 29, Siemens-Road, Icheon-City,  
Gyeonggi-Do, 467-080, Korea  
**Telephone:** +82-31-645-4864  
**Fax:** +82-31-637-0371  
**E-mail:** Sungmin.Jang@continental-corporation.com  
**Contact name:** **Jang Sung Min**

**Manufacturer:** Continental Automotive Systems Corporation  
**Address:** 29, Siemens-Road, Icheon-City,  
Gyeonggi-Do, 467-080, Korea  
**Telephone:** +82-31-645-4864  
**Fax:** +82-31-637-0371  
**E-mail:** Sungmin.Jang@continental-corporation.com  
**Contact name:** **Jang Sung Min**

## 2. Laboratory information

### Address

#### **EMC compliance Ltd.**

480-5 Sin-dong, Yeongtong-gu, Suwon-city, Gyeonggi-do, 443-390, Korea

Telephone Number: 82 31 336 9919

Facsimile Number: 82 505 299 8311

FCC CAB.: KR0040

VCCI Registration No.: R-3327, G-198, C-3706, T-1849

Industry Canada Registration No.: 8035A

KOLAS NO.: 231

### **SITE MAP**

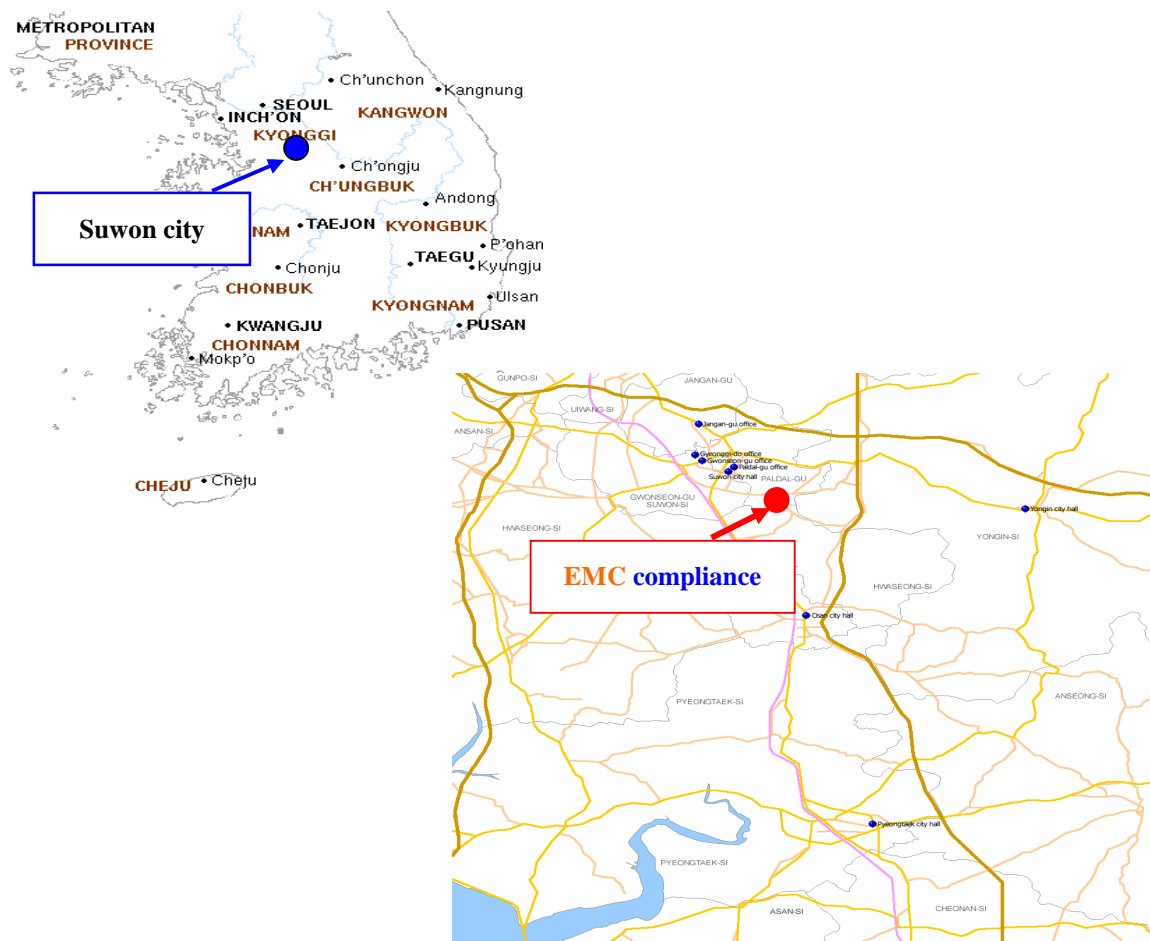

### 3. Test system configuration

#### 3.1 Operation environment

	Temperature	Humidity	Pressure
Chamber(10 m)	: 22 °C	30 % R.H.	-

#### Test site

These testing items were performed following locations;

Test item	Test site
Conducted Emission	Shielded Room
Radiated Emission	10 m Chamber

### 3.2 Measurement Uncertainty

All measurements involve certain levels of uncertainties, especially in field of EMC.

The factors contributing to uncertainties are test receiver, cable loss, antenna factor calibration, Antenna directivity, antenna factor variation with height, antenna phase center variation, antenna frequency interpolation, measurement distance variation, site imperfection, mismatch, and system repeatability. Based on CISPR 16-4-2, the measurement uncertainty level with a 95 % confidence level was applied.

Conducted emission measurement (C.L: Approx 95 %, k = 2)		
Shielded Room (CE#1)	9 kHz ~ 150 kHz: ± 3.82 dB 150 kHz ~ 30 MHz: ± 3.43 dB	
Shielded Room (CE#2)	9 kHz ~ 150 kHz: ± 3.82 dB 150 kHz ~ 30 MHz: ± 3.43 dB	
Shielded Room (CE#3)	9 kHz ~ 150 kHz: ± 4.00 dB 150 kHz ~ 30 MHz: ± 3.63 dB	
Radiated Emission measurement (C.L: Approx 95 %, k = 2)		
10 m Chamber (#F4)	30 MHz ~ 300 MHz	3 m: + 4.56 dB, - 4.58 dB 10 m: + 4.56 dB, - 4.56 dB
	300 MHz ~ 1 000 MHz	3 m: + 4.84 dB, - 4.85 dB 10 m: + 4.71 dB, - 4.72 dB
	1 GHz ~ 6 GHz	3 m: + 6.19 dB, - 6.20 dB
	6 GHz ~ 18 GHz	3 m: + 6.41 dB, - 6.53 dB
10 m Chamber (#F2)	30 MHz ~ 300 MHz	3 m: + 4.86 dB, - 4.88 dB 10 m: + 4.86 dB, - 4.86 dB
	300 MHz ~ 1 000 MHz	3 m: + 4.98 dB, - 4.99 dB 10 m: + 4.85 dB, - 4.87 dB
	1 GHz ~ 6 GHz	3 m: + 6.19 dB, - 6.20 dB
	6 GHz ~ 18 GHz	3 m: + 6.41 dB, - 6.53 dB

## 4. Description of E.U.T.

### 4.1 General information

433.92 MHz Rx

-20~+50 ° C

FSK

### 4.2 Product description

Type of product	Remote Keyless Entry System (Receiver)
Model name (Basic)	SVI-KORX433
Model name (Variant)	-
Difference	-
Trade name	-
Serial no	Engineering Sample
Testing voltage	DC 12 V
Product rating	DC 12 V
Internal clock frequency	433.92 MHz
Note	-

### 4.3 Auxiliary equipments

Type	Model / Part #	Serial number	Manufacturer
DC Power Supply	E3632A	KR01009281	Agilent
Smart Key	-	-	-

#### 4.4 Test configuration

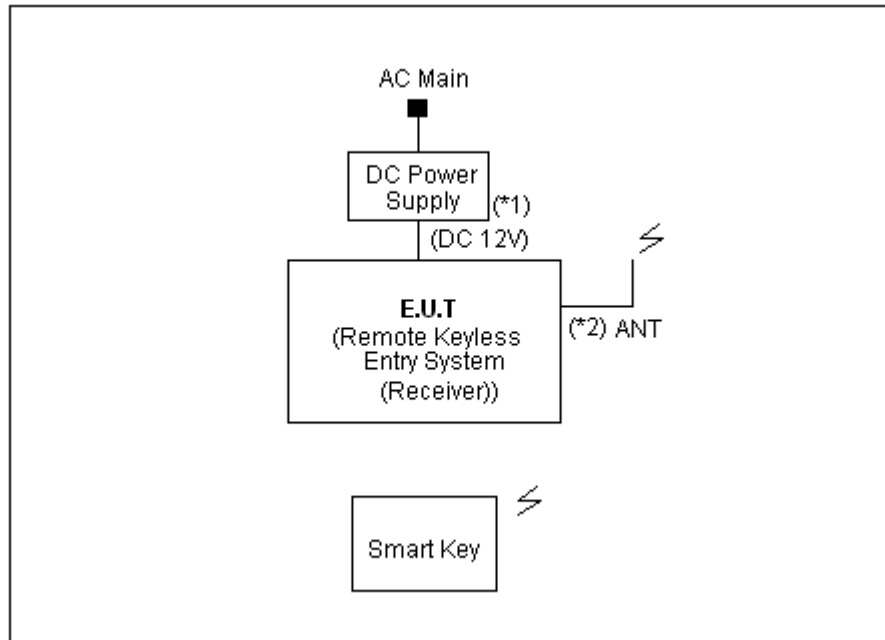

Note	Start		End		Cable	
	Name	I/O port	Name	I/O port	Length (m)	Spec.
1	<b>E.U.T</b> (Remote Keyless Entry System Receiver))	Power	DC Power Supply	Power	1.5	Non-Shield
2		ANT	ANT	ANT	0.2	Non-Shield

#### 4.5 Operating conditions

The EUT was configured as normal intended use.

This test was done at worst case.

Test mode	Normal operating
1	Check the RF Receiver Module Operating status.



## 5. Summary of test results

**In the above configuration tested, The EUT complied with the requirement of the specification**

### 5.1 Summary of EMI emission test results

FCC Part 15 Subpart B (Class B)

ANSI C63.4 – 2009

RSS-Gen Issue 3: 2010

Applied	Test items	Test method	Result
<input type="checkbox"/>	Conducted Emission	ANSI C63.4 – 2009 RSS-Gen Issue 3: 2010	N/A
<input checked="" type="checkbox"/>	Radiated Emission	ANSI C63.4 – 2009 RSS-Gen Issue 3: 2010	Complied

## 6. Test results

### 6.1 Radiated Emission

Test specification	FCC Part 15, Section 15.109(g), Class B, RSS-Gen Issue 3: 2010		
Testing voltage	DC 12 V		
Test facility	10 m Chamber (#F2)		
Test distance	3 m		
Date	2013. 01. 04		
Temperature (°C)	22 °C	Humidity (% R.H.)	30 % R.H.
Remarks	Complied		

#### 6.1.1 Limits of radiated emission measurement

Frequency [MHz]	Class A (dB( $\mu$ V/m)) @ 10 m	Class B (dB( $\mu$ V/m)) @ 3 m
30-88	39	40
88-216	43.5	43.5
216-960	46.4	46
Above 960	49.5	54

\* Note- Alternative standard: CISPR, Pub. 22 \*

#### 6.1.2 Measurement procedure

The test was done at a 10 m chamber with a quasi-peak detector. EUT was placed on a non-metallic table height of 0.8 m above the reference ground plane. Cables were folded back and forth forming a bundle 0.3 m to 0.4 m long and were hanged at a 0.4 m height to the ground plane.

Cables connected to EUT were fixed to cause maximum emission. Test was made with the antenna positioned in both the horizontal and vertical planes of polarization. The measurement antenna was varied in height above the conducting ground plane to obtain the maximum signal strength.

### 6.1.3 Used equipments

Equipment	Model no.	Serial no.	Makers	Next Cal. Date	Used
Test Receiver	ESCI	100710	R&S	2013.11.06	<input checked="" type="checkbox"/>
Bi-Log Antenna	VULB 9168	9168-440	SCHWARZBECK	2013.10.04	<input checked="" type="checkbox"/>
Amplifier	310N	293004	SONOMA INSTRUMENT	2013.11.06	<input checked="" type="checkbox"/>
3 dB Attenuator	8491A	27444	HP	2013.11.06	<input checked="" type="checkbox"/>
Antenna Mast	MA4000-EP	303	Innco Systems	-	<input checked="" type="checkbox"/>
Turn Table	DT2000S-1t	079	Innco Systems	-	<input checked="" type="checkbox"/>
Horn ANT	3115	00086706	ETS	2013.11.21	<input type="checkbox"/>
Amplifier	8449B	3008A01802	AGILENT	2013.05.04	<input type="checkbox"/>
Amplifier	8449B	3008A02343	AGILENT	2013.11.06	<input type="checkbox"/>
Spectrum Analyzer	FSP7	100289	R&S	2013.12.14	<input type="checkbox"/>

### 6.1.4 Sample calculation

The field strength is calculated adding the antenna Factor, cable loss and, Antenna pad adding, subtracting the amplifier gain from the measured reading.

The sample calculation is as follow:

$$\text{Result} = \text{M.R} + \text{C.F}(\text{A.F} + \text{C.L} + 3 \text{ dB Att} - \text{A.G})$$

M.R = Meter Reading

C.F = Correction Factor

A.F = Antenna Factor

C.L = Cable Loss

A.G= Amplifier Gain

3 dB Att = 3 dB Attenuator

If M.R is 30 dB, A.F 12 dB, C.L 5 dB, 3 dB, A.G 35 dB

The result is  $30 + 12 + 5 + 3 - 35 = 15 \text{ dB}(\mu\text{V/m})$

### 6.1.5 Photographs of test setup

\* 30 MHz ~ 1 GHz

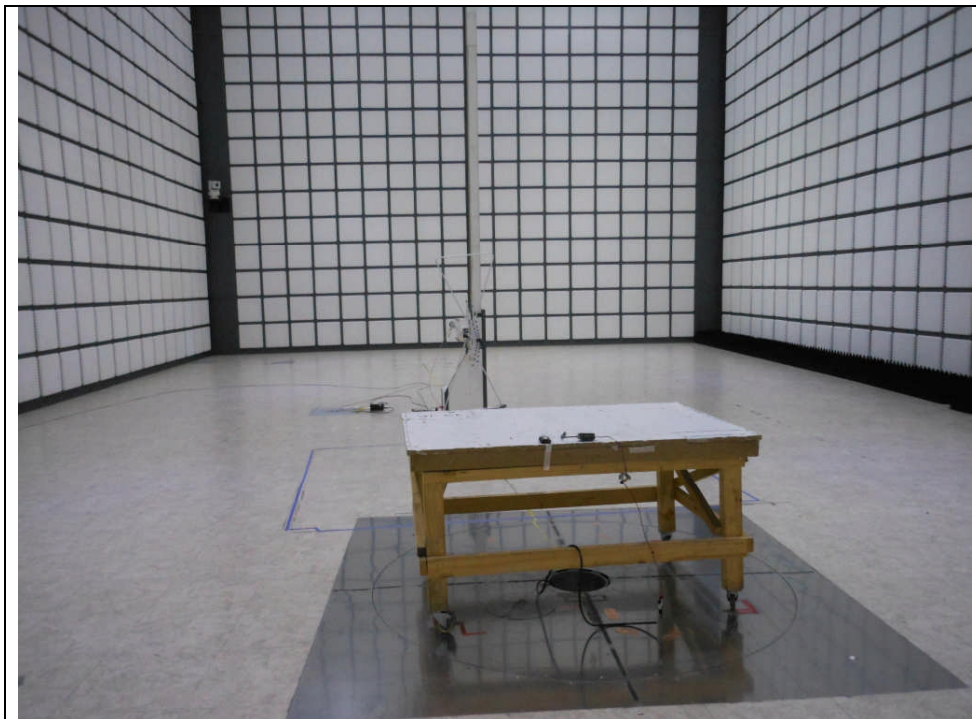
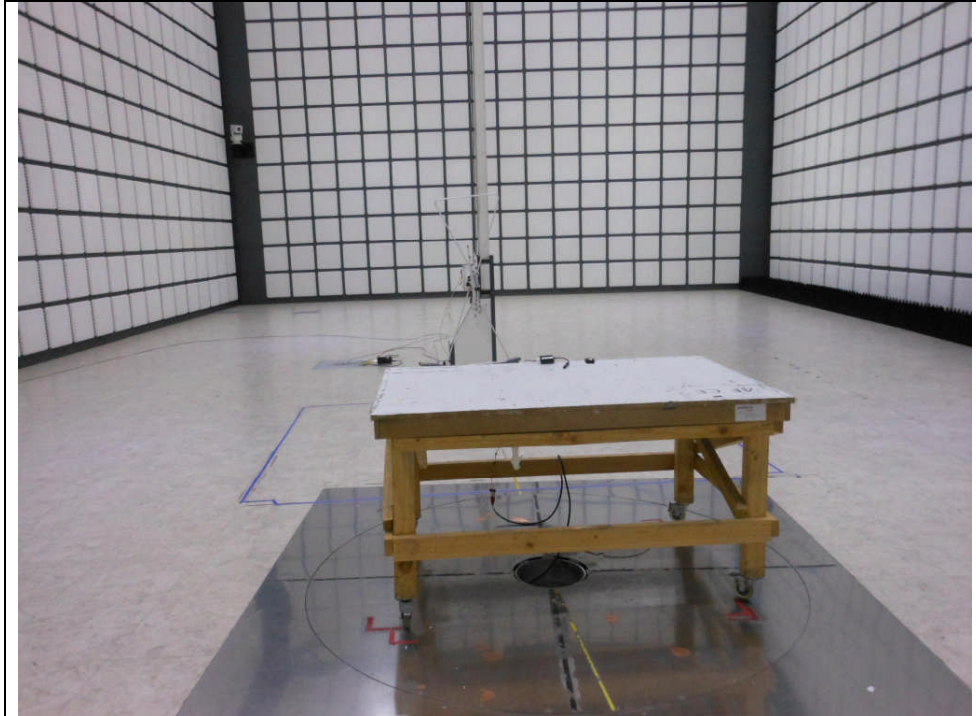

6.1.6 Radiated emission measurement result

\* Graph and Data

\* 30 MHz ~ 1 GHz(SVI-KORX433)

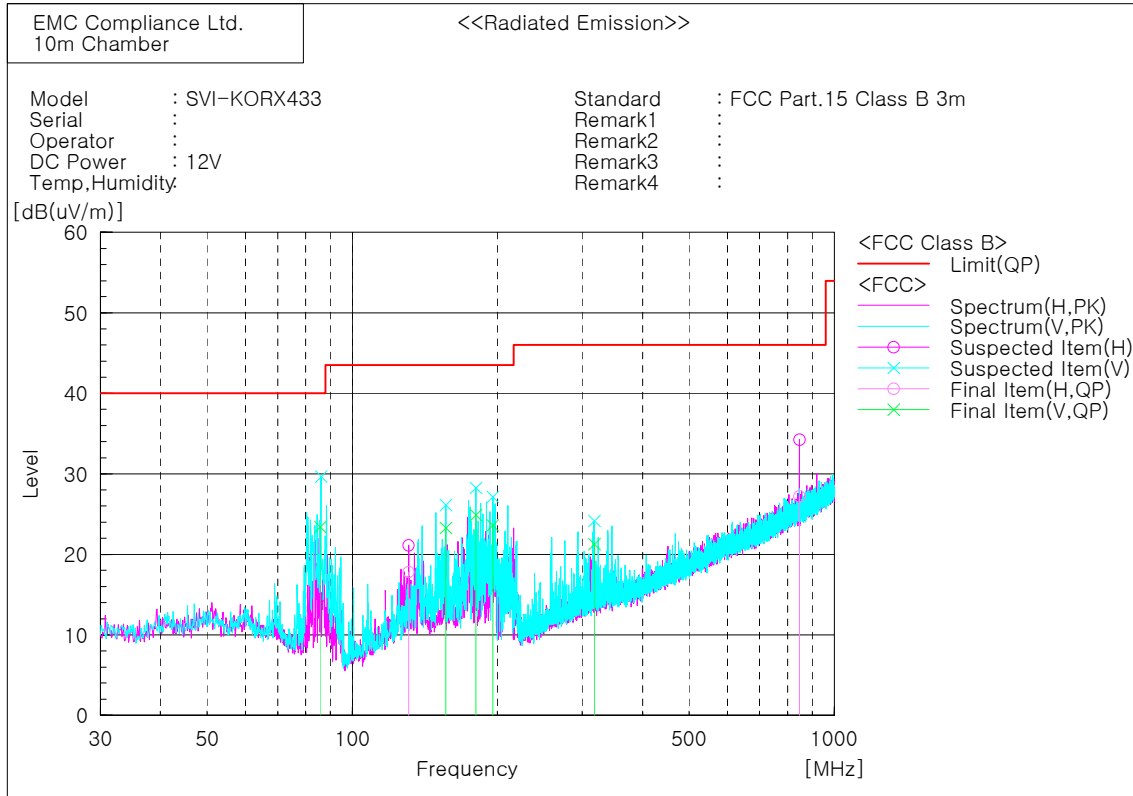

Final Result

No.	Frequency [MHz]	(P)	Reading QP [dB(uV)]	c.f [dB(1/m)]	Result QP [dB(uV/m)]	Limit QP [dB(uV/m)]	Margin QP [dB]	Height [cm]	Angle [deg]
1	85.788	V	42.4	-19.0	23.4	40.0	16.6	201.0	64.8
2	130.759	H	32.6	-14.8	17.8	43.5	25.7	201.0	142.1
3	156.221	V	36.7	-13.4	23.3	43.5	20.2	100.0	66.2
4	180.350	V	39.6	-14.7	24.9	43.5	18.6	201.0	33.3
5	195.628	V	39.7	-16.1	23.6	43.5	19.9	100.0	147.4
6	317.848	V	32.8	-11.5	21.3	46.0	24.7	100.0	294.4
7	846.498	H	27.3	-0.1	27.2	46.0	18.8	100.0	105.2