

Test Mode: LTE Band 41 / 15MHz / 1 RB / QPSK

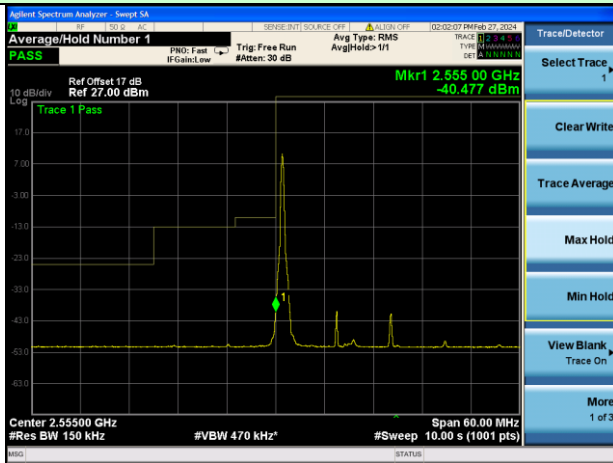

Lowest channel

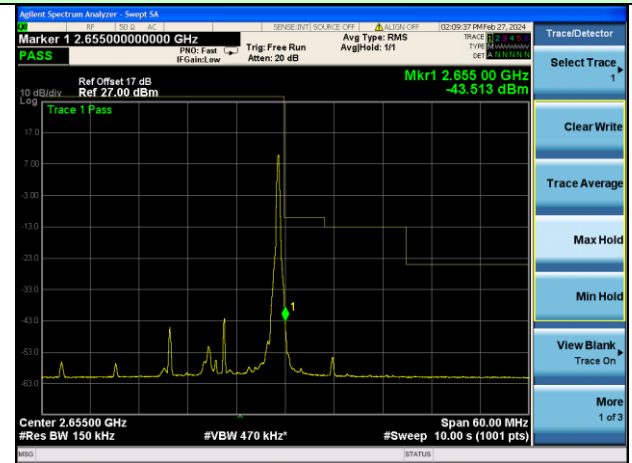

Highest channel

Test Mode: LTE Band 41 / 15MHz / 75RB / QPSK

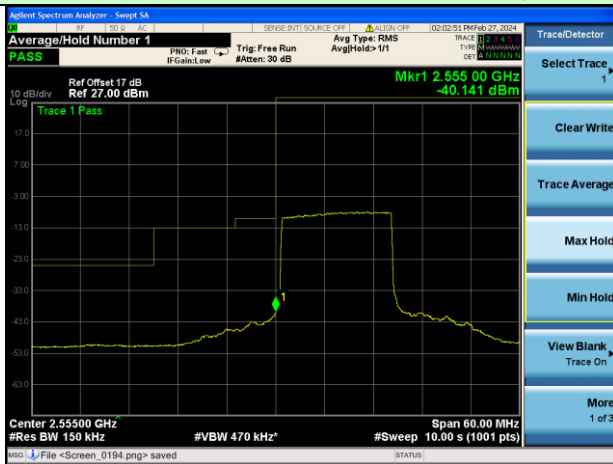

Lowest channel

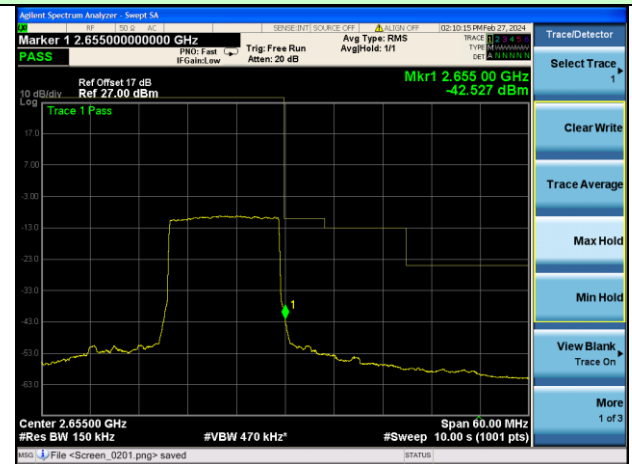

Highest channel

Test Mode: LTE Band 41 / 20MHz / 1RB / QPSK

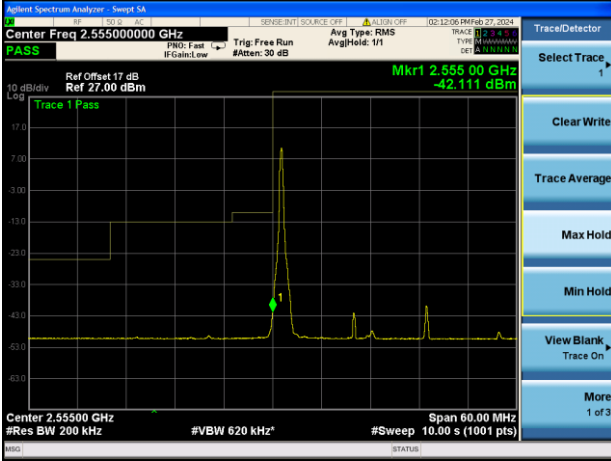

Lowest channel

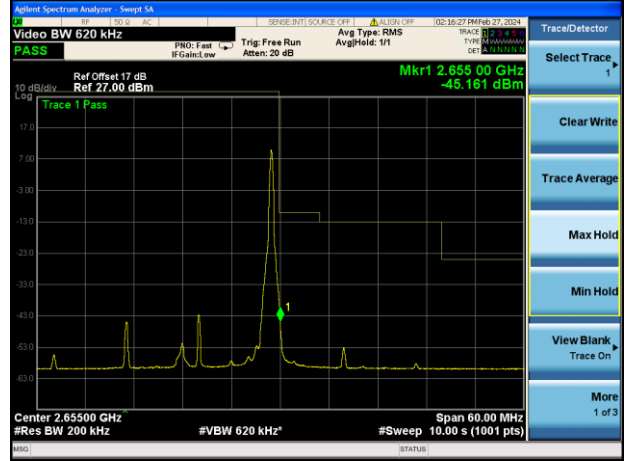

Highest channel

Test Mode: LTE Band 41 / 20MHz / 100RB / QPSK

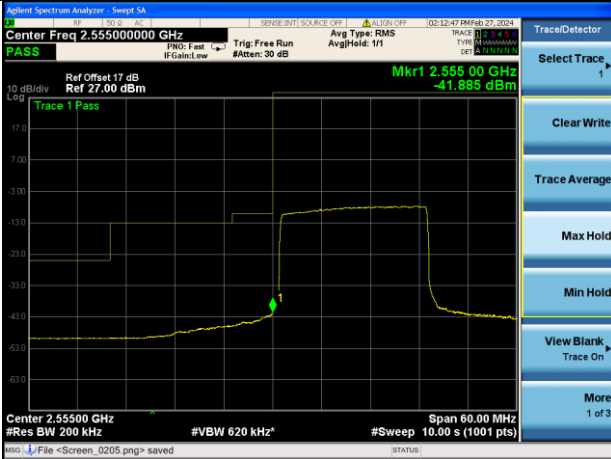

Lowest channel

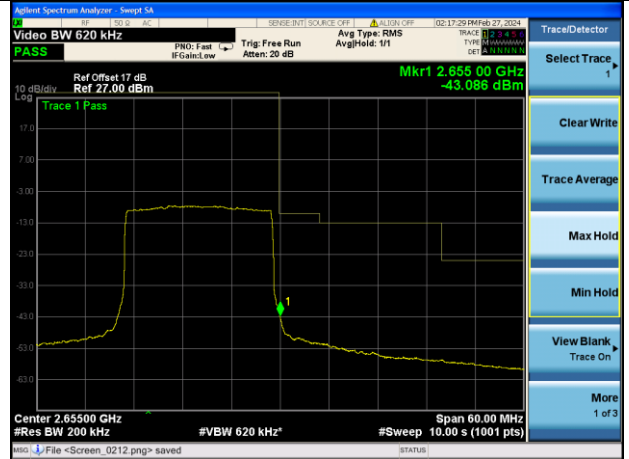

Highest channel

Test Mode: LTE Band 41 / 5MHz / 1RB / 16-QAM

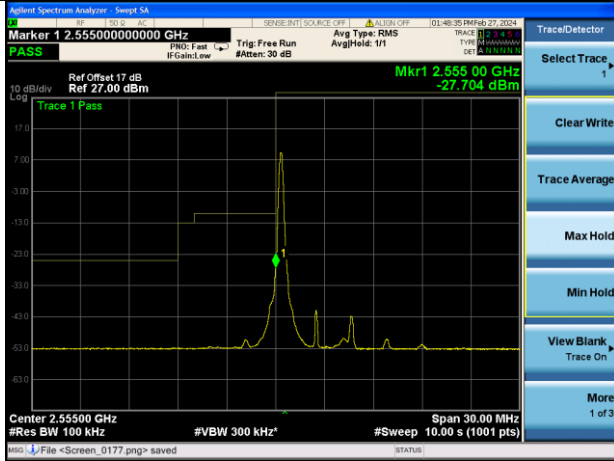

Lowest channel

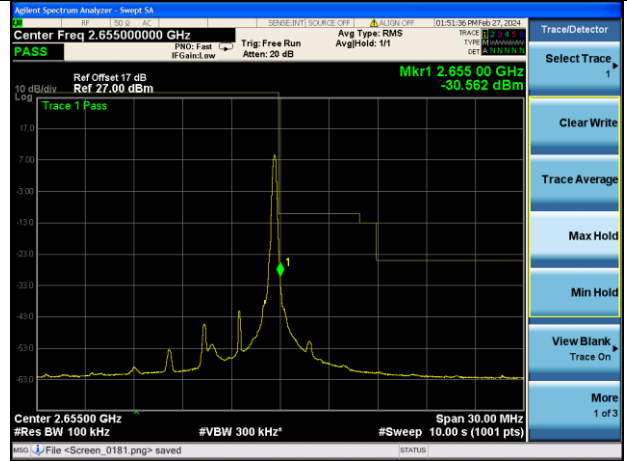

Highest channel

Test Mode: LTE Band 41 / 5MHz / 25RB / 16-QAM

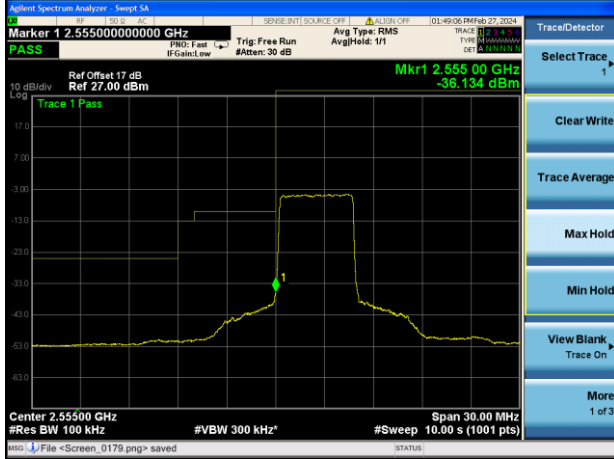

Lowest channel

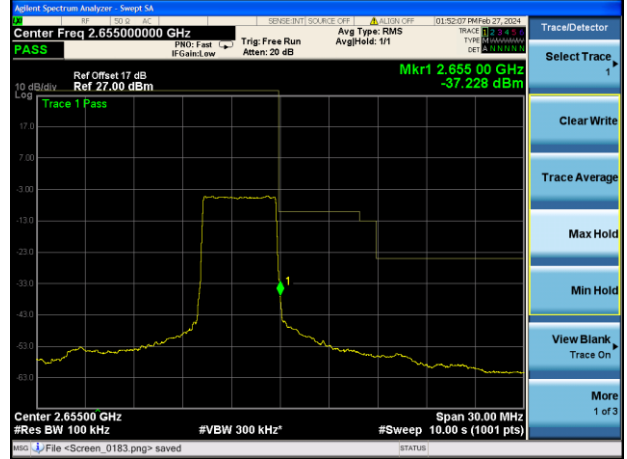

Highest channel

Test Mode: LTE Band 41 / 10MHz / 1 RB / 16-QAM

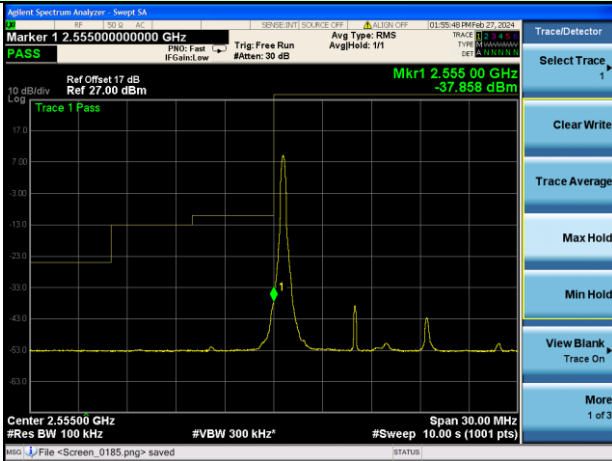

Lowest channel

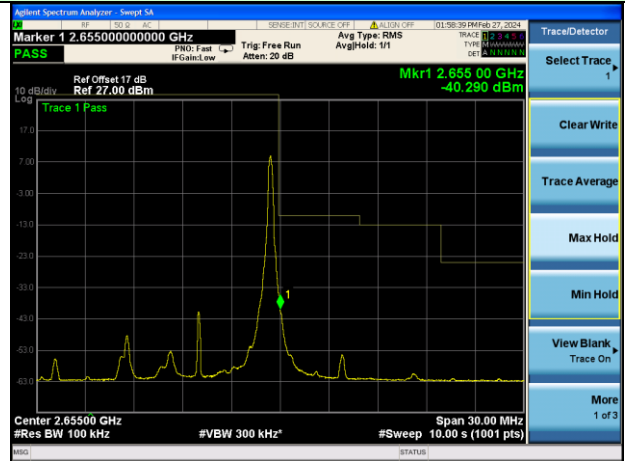

Highest channel

Test Mode: LTE Band 41 / 10MHz / 50RB / 16-QAM

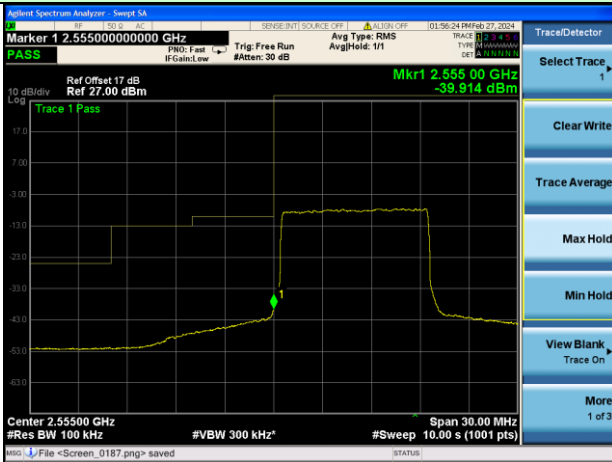

Lowest channel

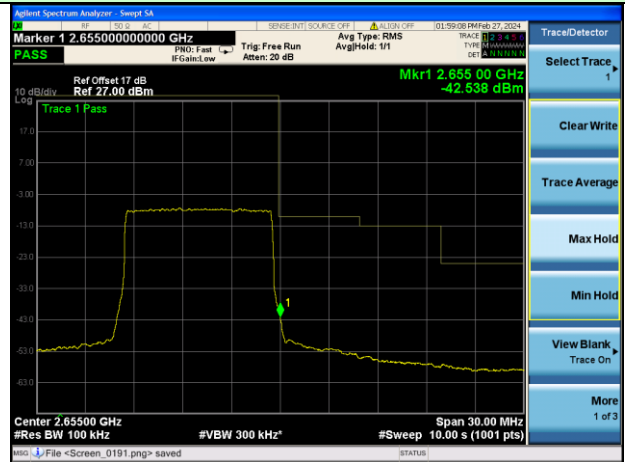

Highest channel

Test Mode: LTE Band 41 / 15MHz / 1 RB / 16-QAM

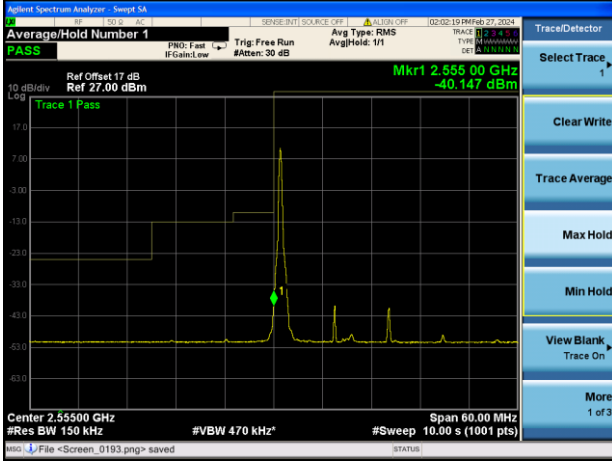

Lowest channel

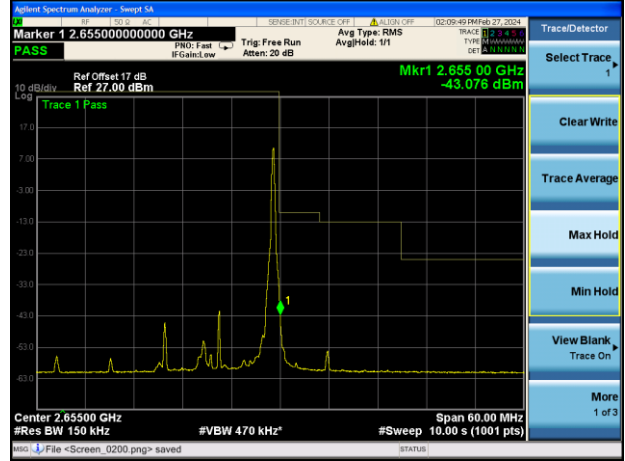

Highest channel

Test Mode: LTE Band 41 / 15MHz / 75RB / 16-QAM

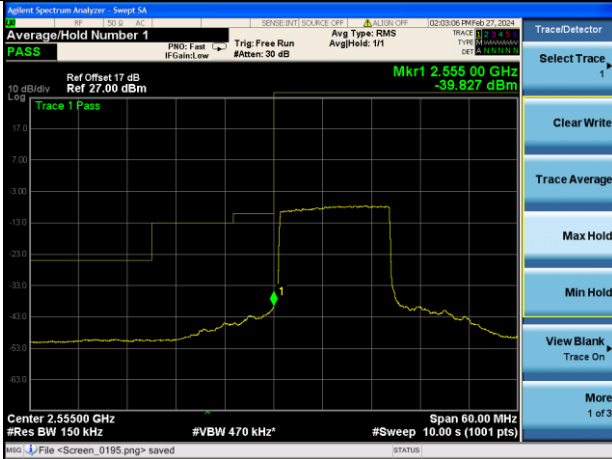

Lowest channel

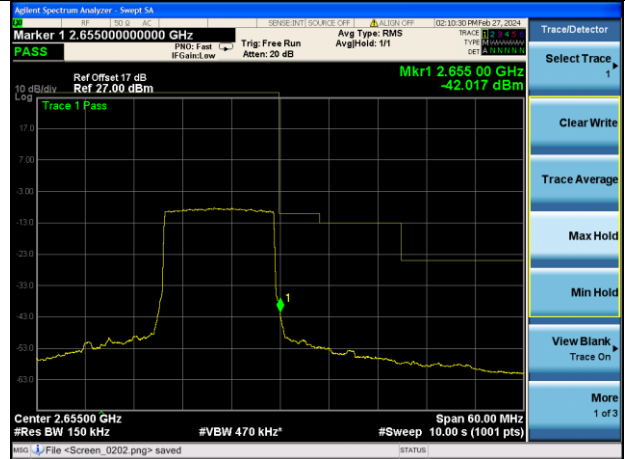

Highest channel

Test Mode: LTE Band 41 / 20MHz / 1RB / 16-QAM

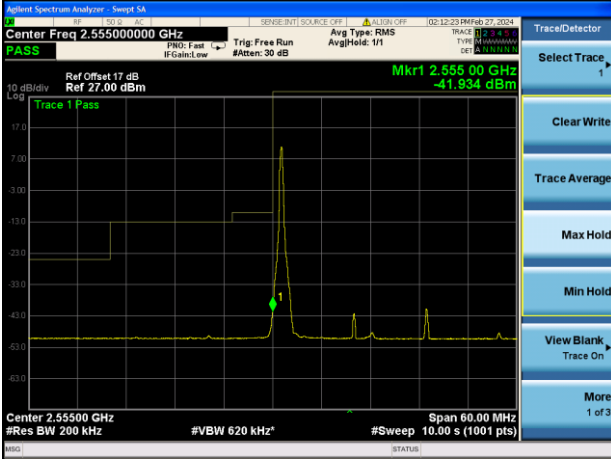

Lowest channel

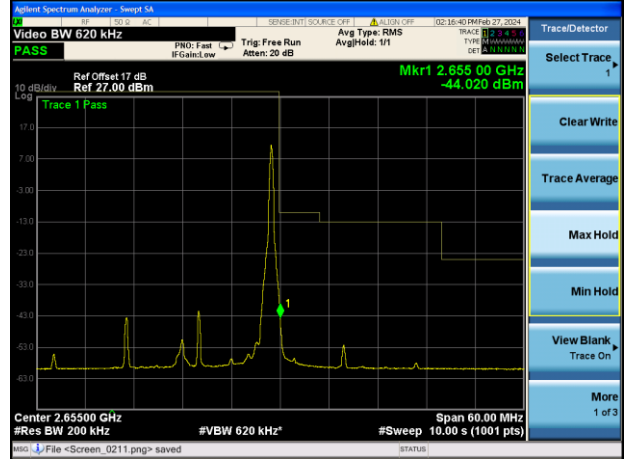

Highest channel

Test Mode: LTE Band 41 / 20MHz / 100RB / 16-QAM

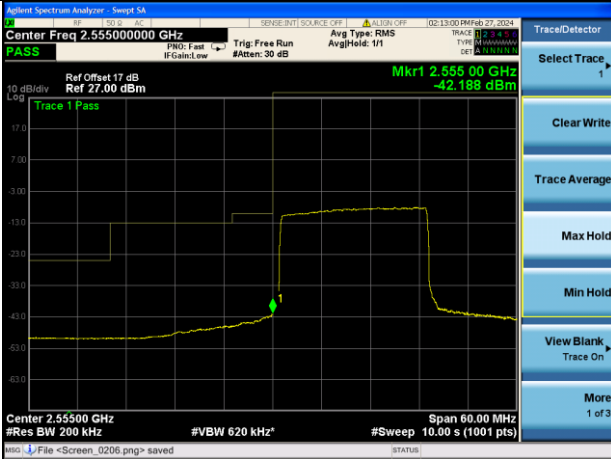

Lowest channel

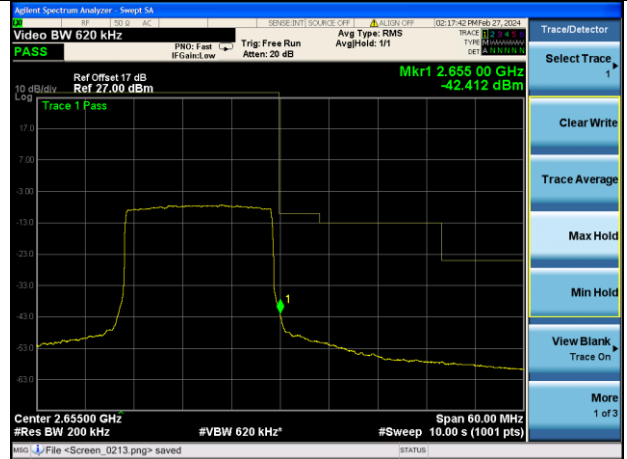

Highest channel

Note: All bandwidth and modulation are tested, only the worst result is reported.

4.8 ERP, EIRP Measurement

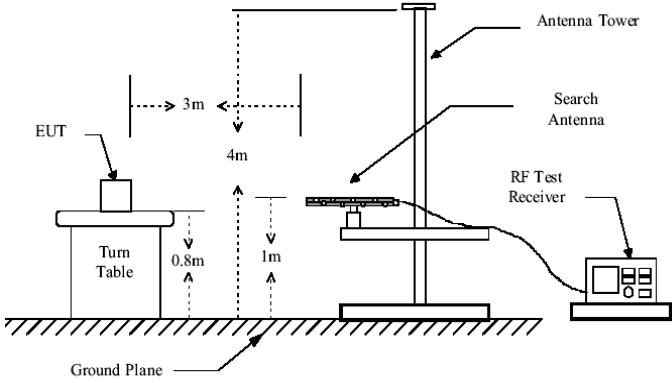
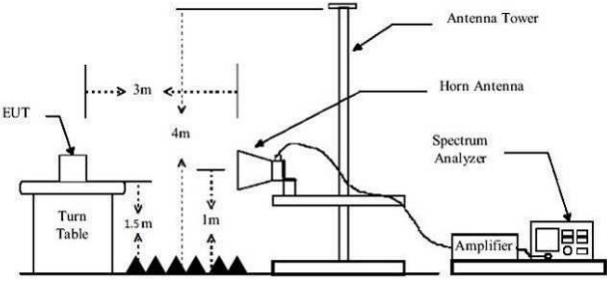
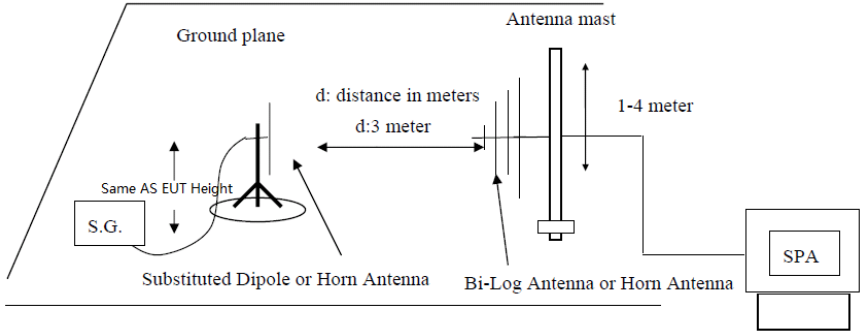
<p>Test Requirement:</p>	<p>FCC part22.913(a), FCC part24.232(b), FCC part 27.50(h) and FCC part 27.53, FCC part90.635(b)</p>
<p>Test Method:</p>	<p>ANSI C63.26:2015</p>
<p>Limit:</p>	<p>LTE Band 5(Upper Band): [7W (ERP) for FCC] LTE Band 7: 2W (EIRP) LTE Band 41: 2W (EIRP)</p>
<p>Test setup:</p>	<p>Below 1GHz</p>  <p>Above 1GHz</p>  <p>Substituted method:</p> 

Test Procedure:	<ol style="list-style-type: none"> 1. The EUT was placed on an non-conductive turntable using a non-conductive support. The radiated emission at the fundamental frequency was measured at 3 m with a test antenna and EMI spectrum analyzer. 2. During the measurement, the EUT was communication with the station. The highest emission was recorded with the rotation of the turntable and the lowering of the test antenna from 4m to 1m. The reading was recorded and the field strength (E in dBuV/m) was calculated. 3. ERP were measured using a substitution method. The EUT was replaced by dipole antenna connected, the S.G. output was recorded and ERP was calculated asfollows: $\text{ERP} = \text{S.G. output (dBm)} + \text{Antenna Gain (dBd)} - \text{Cable Loss (dB)}$ 4. EIRP were measured using a substitution method. The EUT was replaced by or horn antenna connected, the S.G. output was recorded and EIRP was calculated as follows: $\text{EIRP} = \text{S.G. output (dBm)} + \text{Antenna Gain (dBi)} - \text{Cable Loss (dB)}$
Test Instruments:	Refer to section 3 for details
Test mode:	Refer to section 4.1 for details
Test results:	Pass
Remark:	H,E1,E2 mean for EUT polarization of X, Y, Z

Measurement Data

EUT mode	Channel	RB Size	RB Offset	EUT Pol.	Antenna Pol.	ERP(dBm)	Limit (dBm)	Result
LTE Band 5 (1.4MHz) QPSK	Lowest	6	0	H	V	24.62	38.45	Pass
					H	22.97		
				E1	V	24.64		
					H	24.43		
				E2	V	22.78		
					H	23.74		
	Middle	6	0	H	V	22.23	38.45	Pass
					H	23.45		
				E1	V	23.43		
					H	23.07		
				E2	V	22.52		
					H	22.46		
	Highest	6	0	H	V	23.29	38.45	Pass
					H	22.62		
				E1	V	22.95		
					H	22.90		
				E2	V	22.04		
					H	23.01		

EUT mode	Channel	RB Size	RB Offset	EUT Pol.	Antenna Pol.	ERP(dBm)	Limit (dBm)	Result
LTE Band 5 (3MHz) QPSK	Lowest	15	0	H	V	24.37	38.45	Pass
					H	22.95		
				E1	V	24.16		
					H	24.34		
				E2	V	22.15		
					H	23.79		
	Middle	15	0	H	V	22.64	38.45	Pass
					H	23.48		
				E1	V	23.75		
					H	22.80		
				E2	V	22.22		
					H	21.94		
	Highest	15	0	H	V	23.95	38.45	Pass
					H	22.46		
				E1	V	22.82		
					H	22.15		
				E2	V	22.68		
					H	23.05		

EUT mode	Channel	RB Size	RB Offset	EUT Pol.	Antenna Pol.	ERP(dBm)	Limit (dBm)	Result
LTE Band 5 (5MHz) QPSK	Lowest	25	0	H	V	24.53	38.45	Pass
					H	22.14		
				E1	V	24.45		
					H	23.70		
				E2	V	22.95		
					H	23.67		
	Middle	25	0	H	V	22.10	38.45	Pass
					H	23.12		
				E1	V	23.47		
					H	22.76		
				E2	V	22.43		
					H	22.00		
	Highest	25	0	H	V	23.71	38.45	Pass
					H	22.77		
				E1	V	22.54		
					H	22.71		
				E2	V	22.23		
					H	22.97		

EUT mode	Channel	RB Size	RB Offset	EUT Pol.	Antenna Pol.	ERP(dBm)	Limit (dBm)	Result
LTE Band 5 (10MHz) QPSK	Lowest	50	0	H	V	23.85	38.45	Pass
					H	22.48		
				E1	V	24.14		
					H	23.64		
				E2	V	22.90		
					H	23.77		
	Middle	50	0	H	V	22.31	38.45	Pass
					H	23.83		
				E1	V	23.32		
					H	22.67		
				E2	V	22.85		
					H	21.93		
	Highest	50	0	H	V	23.43	38.45	Pass
					H	23.03		
				E1	V	22.88		
					H	22.53		
				E2	V	22.29		
					H	23.12		

EUT mode	Channel	RB Size	RB Offset	EUT Pol.	Antenna Pol.	ERP(dBm)	Limit (dBm)	Result
LTE Band 5 (1.4MHz) 16 QAM	Lowest	6	0	H	V	24.24	38.45	Pass
					H	22.99		
				E1	V	24.21		
					H	24.17		
				E2	V	22.27		
					H	23.66		
	Middle	6	0	H	V	22.36	38.45	Pass
					H	23.55		
				E1	V	23.51		
					H	22.87		
				E2	V	22.51		
					H	22.48		
	Highest	6	0	H	V	23.68	38.45	Pass
					H	22.75		
				E1	V	22.83		
					H	22.68		
				E2	V	22.23		
					H	22.38		

EUT mode	Channel	RB Size	RB Offset	EUT Pol.	Antenna Pol.	ERP(dBm)	Limit (dBm)	Result
LTE Band 5 (3MHz) 16 QAM	Lowest	15	0	H	V	24.68	38.45	Pass
					H	22.33		
				E1	V	23.87		
					H	24.16		
				E2	V	22.49		
					H	24.06		
	Middle	15	0	H	V	22.37	38.45	Pass
					H	23.51		
				E1	V	23.78		
					H	22.79		
				E2	V	22.77		
					H	22.59		
	Highest	15	0	H	V	23.56	38.45	Pass
					H	22.73		
				E1	V	23.15		
					H	22.16		
				E2	V	22.41		
					H	22.84		

EUT mode	Channel	RB Size	RB Offset	EUT Pol.	Antenna Pol.	ERP(dBm)	Limit (dBm)	Result
LTE Band 5 (5MHz) 16 QAM	Lowest	25	0	H	V	23.96	38.45	Pass
					H	22.64		
				E1	V	24.59		
					H	24.43		
				E2	V	22.02		
					H	23.87		
	Middle	25	0	H	V	22.02	38.45	Pass
					H	23.09		
				E1	V	23.62		
					H	23.02		
				E2	V	22.28		
					H	22.18		
	Highest	25	0	H	V	23.38	38.45	Pass
					H	22.63		
				E1	V	22.81		
					H	22.52		
				E2	V	22.02		
					H	22.65		

EUT mode	Channel	RB Size	RB Offset	EUT Pol.	Antenna Pol.	ERP(dBm)	Limit (dBm)	Result
LTE Band 5 (10MHz) 16 QAM	Lowest	50	0	H	V	24.29	38.45	Pass
					H	22.25		
				E1	V	24.44		
					H	23.68		
				E2	V	22.37		
					H	23.44		
	Middle	50	0	H	V	22.17	38.45	Pass
					H	23.61		
				E1	V	23.26		
					H	23.46		
				E2	V	22.86		
					H	21.90		
	Highest	50	0	H	V	23.83	38.45	Pass
					H	23.16		
				E1	V	22.59		
					H	22.02		
				E2	V	22.16		
					H	23.01		

EUT mode	Channel	RB Size	RB Offset	EUT Pol.	Antenna Pol.	EIRP(dBm)	Limit (dBm)	Result
LTE Band 7 (5MHz) QPSK	Lowest	25	0	H	V	23.94	33.00	Pass
					H	22.06		
				E1	V	23.81		
					H	22.95		
				E2	V	23.96		
					H	24.07		
	Middle	25	0	H	V	23.08	33.00	Pass
					H	22.66		
				E1	V	21.90		
					H	23.67		
				E2	V	22.51		
					H	22.98		
	Highest	25	0	H	V	22.32	33.00	Pass
					H	22.20		
				E1	V	22.72		
					H	22.54		
				E2	V	22.14		
					H	23.23		

EUT mode	Channel	RB Size	RB Offset	EUT Pol.	Antenna Pol.	EIRP(dBm)	Limit (dBm)	Result
LTE Band 7 (10MHz) QPSK	Lowest	50	0	H	V	24.51	33.00	Pass
					H	22.29		
				E1	V	23.72		
					H	22.71		
				E2	V	23.51		
					H	23.91		
	Middle	50	0	H	V	23.08	33.00	Pass
					H	22.83		
				E1	V	21.90		
					H	23.60		
				E2	V	22.36		
					H	23.21		
	Highest	50	0	H	V	22.72	33.00	Pass
					H	22.61		
				E1	V	22.74		
					H	22.37		
				E2	V	22.28		
					H	23.42		

EUT mode	Channel	RB Size	RB Offset	EUT Pol.	Antenna Pol.	EIRP(dBm)	Limit (dBm)	Result
LTE Band 7 (15MHz) QPSK	Lowest	75	0	H	V	23.90	33.00	Pass
					H	22.89		
				E1	V	23.98		
					H	22.24		
				E2	V	23.50		
					H	23.54		
	Middle	75	0	H	V	23.52	33.00	Pass
					H	22.03		
				E1	V	22.50		
					H	23.23		
				E2	V	22.38		
					H	22.61		
	Highest	75	0	H	V	22.42	33.00	Pass
					H	21.86		
				E1	V	22.72		
					H	22.76		
				E2	V	22.91		
					H	23.04		

EUT mode	Channel	RB Size	RB Offset	EUT Pol.	Antenna Pol.	EIRP(dBm)	Limit (dBm)	Result
LTE Band 7 (20MHz) QPSK	Lowest	100	0	H	V	24.22	33.00	Pass
					H	22.35		
				E1	V	23.32		
					H	22.11		
				E2	V	23.60		
					H	23.63		
	Middle	100	0	H	V	22.81	33.00	Pass
					H	22.42		
				E1	V	21.97		
					H	23.43		
				E2	V	22.64		
					H	23.43		
	Highest	100	0	H	V	22.48	33.00	Pass
					H	22.27		
				E1	V	22.30		
					H	22.15		
				E2	V	22.22		
					H	23.29		

EUT mode	Channel	RB Size	RB Offset	EUT Pol.	Antenna Pol.	EIRP(dBm)	Limit (dBm)	Result
LTE Band 7 (5MHz) 16 QAM	Lowest	25	0	H	V	24.44	33.00	Pass
					H	22.21		
				E1	V	23.89		
					H	22.44		
				E2	V	24.03		
					H	23.92		
	Middle	25	0	H	V	22.88	33.00	Pass
					H	22.12		
				E1	V	22.62		
					H	23.91		
				E2	V	22.96		
					H	22.56		
	Highest	25	0	H	V	21.92	33.00	Pass
					H	22.22		
				E1	V	22.98		
					H	22.25		
				E2	V	22.10		
					H	23.05		

EUT mode	Channel	RB Size	RB Offset	EUT Pol.	Antenna Pol.	EIRP(dBm)	Limit (dBm)	Result
LTE Band 7 (10MHz) 16 QAM	Lowest	50	0	H	V	24.44	33.00	Pass
					H	22.17		
				E1	V	23.15		
					H	22.84		
				E2	V	23.06		
					H	23.55		
	Middle	50	0	H	V	22.72	33.00	Pass
					H	22.07		
				E1	V	22.46		
					H	23.40		
				E2	V	23.03		
					H	23.33		
	Highest	50	0	H	V	22.47	33.00	Pass
					H	22.15		
				E1	V	22.21		
					H	22.58		
				E2	V	22.96		
					H	23.83		

EUT mode	Channel	RB Size	RB Offset	EUT Pol.	Antenna Pol.	EIRP(dBm)	Limit (dBm)	Result
LTE Band 7 (15MHz) 16 QAM	Lowest	75	0	H	V	23.55	33.00	Pass
					H	22.50		
				E1	V	23.10		
					H	22.77		
				E2	V	23.92		
					H	23.50		
	Middle	75	0	H	V	23.38	33.00	Pass
					H	22.46		
				E1	V	21.67		
					H	23.09		
				E2	V	22.26		
					H	23.39		
	Highest	75	0	H	V	22.36	33.00	Pass
					H	22.58		
				E1	V	22.57		
					H	21.89		
				E2	V	22.34		
					H	23.69		

EUT mode	Channel	RB Size	RB Offset	EUT Pol.	Antenna Pol.	EIRP(dBm)	Limit (dBm)	Result
LTE Band 7 (20MHz) 16 QAM	Lowest	100	0	H	V	24.48	33.00	Pass
					H	21.98		
				E1	V	24.04		
					H	22.64		
				E2	V	23.81		
					H	23.41		
	Middle	100	0	H	V	22.74	33.00	Pass
					H	22.25		
				E1	V	21.87		
					H	24.03		
				E2	V	22.48		
					H	23.44		
	Highest	100	0	H	V	22.27	33.00	Pass
					H	21.74		
				E1	V	22.24		
					H	22.39		
				E2	V	22.33		
					H	23.78		

EUT mode	Channel	RB Size	RB Offset	EUT Pol.	Antenna Pol.	EIRP(dBm)	Limit (dBm)	Result
LTE Band 41 (5MHz) QPSK	Lowest	25	0	H	V	24.20	33.00	Pass
					H	22.87		
				E1	V	24.04		
					H	22.08		
				E2	V	23.26		
					H	23.23		
	Middle	25	0	H	V	23.05	33.00	Pass
					H	22.09		
				E1	V	21.83		
					H	23.37		
				E2	V	23.07		
					H	22.98		
	Highest	25	0	H	V	22.56	33.00	Pass
					H	22.64		
				E1	V	23.10		
					H	22.11		
				E2	V	22.90		
					H	23.21		

EUT mode	Channel	RB Size	RB Offset	EUT Pol.	Antenna Pol.	EIRP(dBm)	Limit (dBm)	Result
LTE Band 41 (10MHz) QPSK	Lowest	50	0	H	V	24.34	33.00	Pass
					H	22.74		
				E1	V	23.29		
					H	22.39		
				E2	V	23.08		
					H	23.61		
	Middle	50	0	H	V	22.90	33.00	Pass
					H	22.17		
				E1	V	22.45		
					H	23.21		
				E2	V	22.76		
					H	23.30		
	Highest	50	0	H	V	22.52	33.00	Pass
					H	21.84		
				E1	V	22.47		
					H	22.67		
				E2	V	22.19		
					H	23.05		

EUT mode	Channel	RB Size	RB Offset	EUT Pol.	Antenna Pol.	EIRP(dBm)	Limit (dBm)	Result
LTE Band 41 (15MHz) QPSK	Lowest	75	0	H	V	24.44	33.00	Pass
					H	22.08		
				E1	V	23.71		
					H	21.97		
				E2	V	23.69		
					H	23.74		
	Middle	75	0	H	V	23.11	33.00	Pass
					H	22.22		
				E1	V	22.28		
					H	23.24		
				E2	V	22.96		
					H	22.79		
	Highest	75	0	H	V	22.31	33.00	Pass
					H	22.33		
				E1	V	22.37		
					H	22.21		
				E2	V	22.83		
					H	23.68		

EUT mode	Channel	RB Size	RB Offset	EUT Pol.	Antenna Pol.	EIRP(dBm)	Limit (dBm)	Result
LTE Band 41 (20MHz) QPSK	Lowest	100	0	H	V	23.82	33.00	Pass
					H	22.61		
				E1	V	23.50		
					H	22.12		
				E2	V	24.04		
					H	23.48		
	Middle	100	0	H	V	22.98	33.00	Pass
					H	22.55		
				E1	V	21.66		
					H	24.03		
				E2	V	22.30		
					H	22.65		
	Highest	100	0	H	V	22.50	33.00	Pass
					H	21.94		
				E1	V	22.66		
					H	22.79		
				E2	V	22.41		
					H	23.09		

EUT mode	Channel	RB Size	RB Offset	EUT Pol.	Antenna Pol.	EIRP(dBm)	Limit (dBm)	Result
LTE Band 41 (5MHz) 16 QAM	Lowest	25	0	H	V	24.48	33.00	Pass
					H	22.93		
				E1	V	23.78		
					H	22.78		
				E2	V	23.19		
					H	24.17		
	Middle	25	0	H	V	22.75	33.00	Pass
					H	22.73		
				E1	V	22.56		
					H	23.72		
				E2	V	22.58		
					H	22.75		
	Highest	25	0	H	V	22.21	33.00	Pass
					H	22.50		
				E1	V	22.37		
					H	22.65		
				E2	V	22.11		
					H	23.64		

EUT mode	Channel	RB Size	RB Offset	EUT Pol.	Antenna Pol.	EIRP(dBm)	Limit (dBm)	Result
LTE Band 41 (10MHz) 16 QAM	Lowest	50	0	H	V	23.69	33.00	Pass
					H	22.76		
				E1	V	23.12		
					H	22.80		
				E2	V	23.43		
					H	24.15		
	Middle	50	0	H	V	23.33	33.00	Pass
					H	22.20		
				E1	V	21.88		
					H	23.41		
				E2	V	23.19		
					H	23.08		
	Highest	50	0	H	V	22.10	33.00	Pass
					H	22.51		
				E1	V	22.41		
					H	22.12		
				E2	V	22.24		
					H	23.69		

EUT mode	Channel	RB Size	RB Offset	EUT Pol.	Antenna Pol.	EIRP(dBm)	Limit (dBm)	Result
LTE Band 41 (15MHz) 16 QAM	Lowest	75	0	H	V	24.13	33.00	Pass
					H	22.53		
				E1	V	23.80		
					H	22.68		
				E2	V	23.58		
					H	23.44		
	Middle	75	0	H	V	23.33	33.00	Pass
					H	22.58		
				E1	V	22.02		
					H	24.00		
				E2	V	23.18		
					H	23.11		
	Highest	75	0	H	V	22.15	33.00	Pass
					H	22.03		
				E1	V	23.14		
					H	22.40		
				E2	V	22.76		
					H	23.07		

EUT mode	Channel	RB Size	RB Offset	EUT Pol.	Antenna Pol.	EIRP(dBm)	Limit (dBm)	Result
LTE Band 41 (20MHz) 16 QAM	Lowest	100	0	H	V	24.03	33.00	Pass
					H	22.72		
				E1	V	23.72		
					H	22.67		
				E2	V	23.91		
					H	23.31		
	Middle	100	0	H	V	23.01	33.00	Pass
					H	22.64		
				E1	V	22.39		
					H	23.81		
				E2	V	22.66		
					H	22.59		
	Highest	100	0	H	V	22.73	33.00	Pass
					H	22.20		
				E1	V	22.46		
					H	22.55		
				E2	V	22.45		
					H	23.48		

4.9 Field strength of spurious radiation measurement

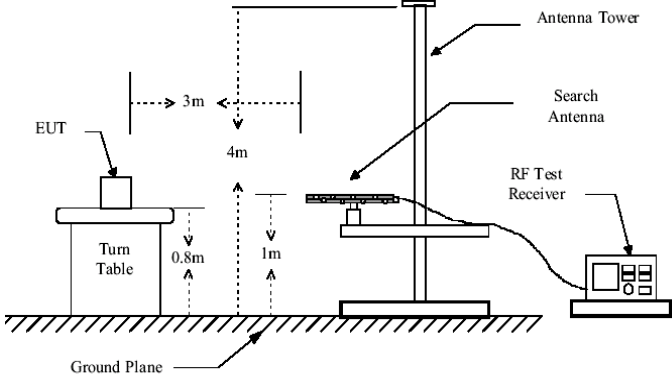
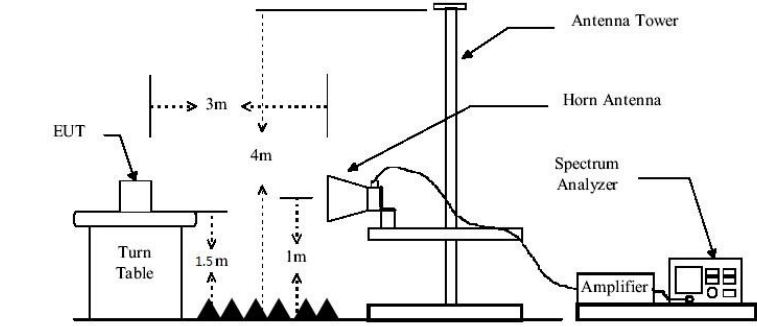
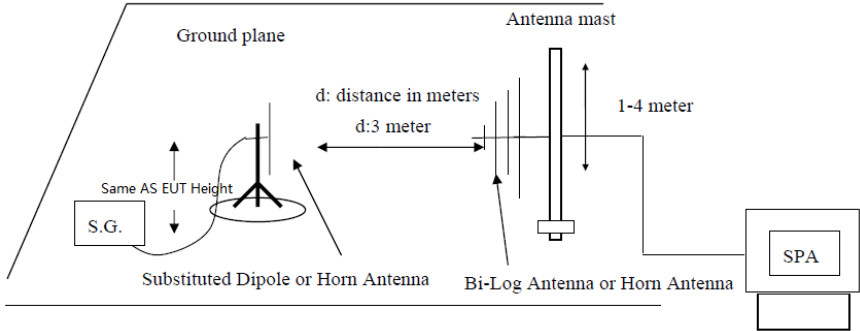
<p>Test Requirement:</p>	<p>FCC part22.913(a), FCC part24.238(a) and FCC part27.53, FCC part90.691</p>
<p>Test Method:</p>	<p>ANSI C63.26:2015</p>
<p>Limit:</p>	<p>Band 5:-13dBm Band 7/41:-25dBm</p>
<p>Test setup:</p>	<p>Below 1GHz</p>  <p>Above 1GHz</p>  <p>Substituted method:</p> 

Test Procedure:	<ol style="list-style-type: none"> 1. The EUT was placed on a non-conductive turntable using a non-conductive support. The radiated emission at the fundamental frequency was measured at 3 m with a test antenna and EMI spectrum analyzer. 2. During the tests, the antenna height and the EUT azimuth were varied in order to identify the maximum level of emissions from the EUT. This maximization process was repeated with the EUT positioned in each of its three orthogonal orientations. 3. The frequency range up to tenth harmonic was investigated for each of three fundamental frequency (low, middle and high channels). Once spurious emission was identified, the power of the emission was determined using the substitution method. 4. The spurious emissions attenuation was calculated as the difference between radiated power at the fundamental frequency and the spurious emissions frequency. $\text{ERP / EIRP} = \text{S.G. output (dBm)} + \text{Antenna Gain(dB/dBi)} - \text{Cable Loss (dB)}$
Test Instruments:	Refer to section 3 for details
Test mode:	Refer to section 4.1 for details
Test results:	Pass

Measurement Data:

Test mode:		LTE Band 5(1.4MHz)		Test channel:	Lowest
Frequency (MHz)	Spurious Emission		Limit (dBm)	Result	
	Polarization	Level (dBm)			
1649.40	Vertical	-37.21	-13.00	Pass	
2474.10	V	-41.20			
3298.80	V	-38.52			
4123.50	V	-41.53			
4948.20	V	---			
1649.40	Horizontal	-42.07	-13.00	Pass	
2474.10	H	-38.25			
3298.80	H	-41.10			
4123.50	H	-49.50			
4948.20	H	---			
Test mode:		LTE Band 5(1.4MHz)		Test channel:	Middle
Frequency (MHz)	Spurious Emission		Limit (dBm)	Result	
	Polarization	Level (dBm)			
1673.00	Vertical	-34.89	-13.00	Pass	
2509.50	V	-43.10			
3346.00	V	-35.41			
4182.50	V	-44.84			
5019.00	V	---			
1673.00	Horizontal	-38.55	-13.00	Pass	
2509.50	H	-44.27			
3346.00	H	-41.76			
4182.50	H	-49.33			
5019.00	H	---			
Test mode:		LTE Band 5(1.4MHz)		Test channel:	Highest
Frequency (MHz)	Spurious Emission		Limit (dBm)	Result	
	Polarization	Level (dBm)			
1696.60	Vertical	-35.95	-13.00	Pass	
2544.90	V	-37.47			
3393.20	V	-40.77			
4241.50	V	-44.28			
5089.80	V	---			
1696.60	Horizontal	-41.54	-13.00	Pass	
2544.90	H	-45.56			
3393.20	H	-44.40			
4241.50	H	-45.00			
5089.80	H	---			

Remark :

1. The emission behaviour belongs to narrowband spurious emission, all modes investigated and only worst case is reported.
2. Remark"---" means that the emission level is too low (20dB lower than the limit) to be measured
3. The emission levels of below 1 GHz are very lower (20dB lower than the limit) than the limit and not show in test report.

Test mode:	LTE Band 7(5MHz)		Test channel:	Lowest
Frequency (MHz)	Spurious Emission		Limit (dBm)	Result
	Polarization	Level (dBm)		
5005.00	Vertical	-36.59	-25.00	Pass
7507.50	V	-40.37		
10010.00	V	-36.37		
12512.50	V	-39.90		
15015.00	V	---		
5005.00	Horizontal	-37.71	-25.00	Pass
7507.50	H	-39.94		
10010.00	H	-44.05		
12512.50	H	-45.81		
15015.00	H	---		
Test mode:	LTE Band 7(5MHz)		Test channel:	Middle
Frequency (MHz)	Spurious Emission		Limit (dBm)	Result
	Polarization	Level (dBm)		
5070.00	Vertical	-34.79	-25.00	Pass
7605.00	V	-39.64		
10140.00	V	-42.05		
12675.00	V	-44.31		
15210.00	V	---		
5070.00	Horizontal	-37.22	-25.00	Pass
7605.00	H	-41.09		
10140.00	H	-43.97		
12675.00	H	-49.42		
15210.00	H	---		
Test mode:	LTE Band 7(5MHz)		Test channel:	Highest
Frequency (MHz)	Spurious Emission		Limit (dBm)	Result
	Polarization	Level (dBm)		
5135.00	Vertical	-35.12	-25.00	Pass
7702.50	V	-41.22		
10270.00	V	-39.83		
12837.50	V	-45.50		
15405.00	V	---		
5135.00	Horizontal	-40.52	-25.00	Pass
7702.50	H	-45.93		
10270.00	H	-43.53		
12837.50	H	-49.33		
15405.00	H	---		

Remark :

1. The emission behaviour belongs to narrowband spurious emission, all modes investigated and only worst case is reported.
2. Remark"---" means that the emission level is too low (20dB lower than the limit) to be measured
3. The emission levels of below 1 GHz are very lower (20dB lower than the limit) than the limit and not show in test report.

Test mode:		LTE Band 41(5MHz)		Test channel:	Lowest
Frequency (MHz)	Spurious Emission		Limit (dBm)	Result	
	Polarization	Level (dBm)			
5005.00	Vertical	-37.03	-25.00	Pass	
7507.50	V	-36.09			
10010.00	V	-38.74			
12512.50	V	-42.88			
15015.00	V	---			
5005.00	Horizontal	-40.25	-25.00	Pass	
7507.50	H	-41.70			
10010.00	H	-42.82			
12512.50	H	-44.82			
15015.00	H	---			
Test mode:		LTE Band 41(5MHz)		Test channel:	Middle
Frequency (MHz)	Spurious Emission		Limit (dBm)	Result	
	Polarization	Level (dBm)			
5070.00	Vertical	-35.37	-25.00	Pass	
7605.00	V	-39.08			
10140.00	V	-41.16			
12675.00	V	-42.90			
15210.00	V	---			
5070.00	Horizontal	-42.57	-25.00	Pass	
7605.00	H	-41.80			
10140.00	H	-47.89			
12675.00	H	-48.36			
15210.00	H	---			
Test mode:		LTE Band 41(5MHz)		Test channel:	Highest
Frequency (MHz)	Spurious Emission		Limit (dBm)	Result	
	Polarization	Level (dBm)			
5135.00	Vertical	-37.96	-25.00	Pass	
7702.50	V	-36.54			
10270.00	V	-40.85			
12837.50	V	-44.32			
15405.00	V	---			
5135.00	Horizontal	-34.98	-25.00	Pass	
7702.50	H	-38.35			
10270.00	H	-41.35			
12837.50	H	-44.79			
15405.00	H	---			

Remark :

- 1 The emission behaviour belongs to narrowband spurious emission, all modes investigated and only worst case is reported.
- 2 Remark"---" means that the emission level is too low (20dB lower than the limit) to be measured
- 3 The emission levels of below 1 GHz are very lower (20dB lower than the limit) than the limit and not show in test report.

16 QAM Mode:

Test mode:		LTE Band 5(1.4MHz)		Test channel:	Lowest
Frequency (MHz)	Spurious Emission		Limit (dBm)	Result	
	Polarization	Level (dBm)			
1649.40	Vertical	-34.83	-13.00	Pass	
2474.10	V	-41.26			
3298.80	V	-36.79			
4123.50	V	-44.99			
4948.20	V	---			
1649.40	Horizontal	-36.91	-13.00	Pass	
2474.10	H	-43.10			
3298.80	H	-43.52			
4123.50	H	-48.80			
4948.20	H	---			
Test mode:		LTE Band 5(1.4MHz)		Test channel:	Middle
Frequency (MHz)	Spurious Emission		Limit (dBm)	Result	
	Polarization	Level (dBm)			
1673.00	Vertical	-38.70	-13.00	Pass	
2509.50	V	-38.25			
3346.00	V	-41.20			
4182.50	V	-40.24			
5019.00	V	---			
1673.00	Horizontal	-38.45	-13.00	Pass	
2509.50	H	-39.56			
3346.00	H	-43.79			
4182.50	H	-45.95			
5019.00	H	---			
Test mode:		LTE Band 5(1.4MHz)		Test channel:	Highest
Frequency (MHz)	Spurious Emission		Limit (dBm)	Result	
	Polarization	Level (dBm)			
1696.60	Vertical	-37.32	-13.00	Pass	
2544.90	V	-38.83			
3393.20	V	-40.37			
4241.50	V	-45.27			
5089.80	V	---			
1696.60	Horizontal	-42.59	-13.00	Pass	
2544.90	H	-41.18			
3393.20	H	-42.39			
4241.50	H	-48.58			
5089.80	H	---			

Remark :

- 1 The emission behaviour belongs to narrowband spurious emission, all modes investigated and only worst case is reported.
- 2 Remark"---" means that the emission level is too low (20dB lower than the limit) to be measured
- 3 The emission levels of below 1 GHz are very lower (20dB lower than the limit) than the limit and not show in test report.

Test mode:	LTE Band 7(5MHz)		Test channel:	Lowest
Frequency (MHz)	Spurious Emission		Limit (dBm)	Result
	Polarization	Level (dBm)		
5005.00	Vertical	-38.50	-25.00	Pass
7507.50	V	-36.36		
10010.00	V	-35.37		
12512.50	V	-39.25		
15015.00	V	---		
5005.00	Horizontal	-36.09	-25.00	Pass
7507.50	H	-41.32		
10010.00	H	-42.34		
12512.50	H	-46.50		
15015.00	H	---		
Test mode:	LTE Band 7(5MHz)		Test channel:	Middle
Frequency (MHz)	Spurious Emission		Limit (dBm)	Result
	Polarization	Level (dBm)		
5070.00	Vertical	-34.04	-25.00	Pass
7605.00	V	-43.53		
10140.00	V	-37.19		
12675.00	V	-42.02		
15210.00	V	---		
5070.00	Horizontal	-36.81	-25.00	Pass
7605.00	H	-45.60		
10140.00	H	-41.01		
12675.00	H	-44.63		
15210.00	H	---		
Test mode:	LTE Band 7(5MHz)		Test channel:	Highest
Frequency (MHz)	Spurious Emission		Limit (dBm)	Result
	Polarization	Level (dBm)		
5135.00	Vertical	-38.17	-25.00	Pass
7702.50	V	-36.65		
10270.00	V	-37.95		
12837.50	V	-42.59		
15405.00	V	---		
5135.00	Horizontal	-38.66	-25.00	Pass
7702.50	H	-40.50		
10270.00	H	-41.49		
12837.50	H	-47.68		
15405.00	H	---		

Remark :

- 1 The emission behaviour belongs to narrowband spurious emission, all modes investigated and only worst case is reported.
- 2 Remark"---" means that the emission level is too low (20dB lower than the limit) to be measured
- 3 The emission levels of below 1 GHz are very lower (20dB lower than the limit) than the limit and not show in test report.

Test mode:	LTE Band 41 (5MHz)		Test channel:	Lowest
Frequency (MHz)	Spurious Emission		Limit (dBm)	Result
	Polarization	Level (dBm)		
3701.40	Vertical	-33.80	-13.00	Pass
5552.10	V	-35.64		
7402.80	V	-38.09		
9253.50	V	-46.15		
11104.20	V	---		
3701.40	Horizontal	-41.95	-13.00	Pass
5552.10	H	-41.11		
7402.80	H	-47.84		
9253.50	H	-46.59		
11104.20	H	---		
Test mode:	LTE Band 41 (5MHz)		Test channel:	Middle
Frequency (MHz)	Spurious Emission		Limit (dBm)	Result
	Polarization	Level (dBm)		
3760.00	Vertical	-39.83	-13.00	Pass
5640.00	V	-43.11		
7520.00	V	-38.02		
9400.00	V	-42.98		
11280.00	V	---		
3760.00	Horizontal	-35.38	-13.00	Pass
5640.00	H	-41.10		
7520.00	H	-42.95		
9400.00	H	-41.69		
11280.00	H	---		
Test mode:	LTE Band 41 (5MHz)		Test channel:	Highest
Frequency (MHz)	Spurious Emission		Limit (dBm)	Result
	Polarization	Level (dBm)		
3818.60	Vertical	-36.13	-13.00	Pass
5727.90	V	-42.72		
7637.20	V	-42.08		
9546.50	V	-45.62		
11455.80	V	---		
3818.60	Horizontal	-40.53	-13.00	Pass
5727.90	H	-41.43		
7637.20	H	-47.38		
9546.50	H	-49.02		
11455.80	H	---		

Remark :

- 1 The emission behaviour belongs to narrowband spurious emission, all modes investigated and only worst case is reported.
- 2 Remark"---" means that the emission level is too low (20dB lower than the limit) to be measured
- 3 The emission levels of below 1 GHz are very lower (20dB lower than the limit) than the limit and not show in test report.

4.10 Frequency stability V.S. Temperature measurement

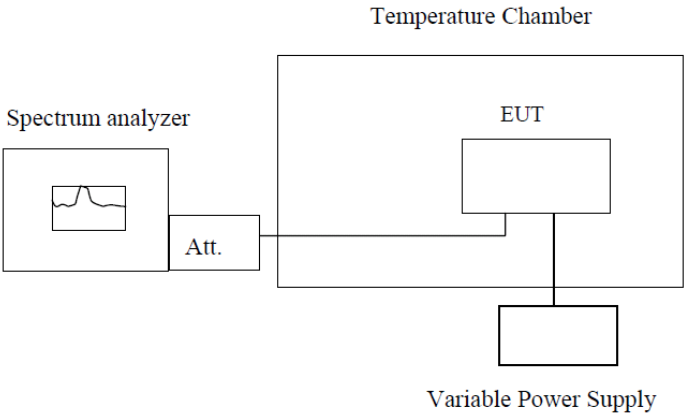
Test Requirement:	FCC Part2.1055(a)(1)(b), FCC part90.213.(a)
Test Method:	ANSI C63.26:2015
Limit:	2.5ppm(Part 22) Within the authorized bands of operation(Part 24, Part 27)
Test setup:	 <p style="text-align: center;">Temperature Chamber</p> <p style="text-align: center;">Spectrum analyzer</p> <p style="text-align: center;">Att.</p> <p style="text-align: center;">EUT</p> <p style="text-align: center;">Variable Power Supply</p> <p>Note : Measurement setup for testing on Antenna connector</p>
Test procedure:	<ol style="list-style-type: none"> 1. The equipment under test was connected to an external DC power supply and input rated voltage. 2. RF output was connected to a frequency counter or spectrum analyzer via feed through attenuators. 3. The EUT was placed inside the temperature chamber. 4. Set the spectrum analyzer RBW low enough to obtain the desired frequency resolution and measure EUT 25°C operating frequency as reference frequency. 5. Turn EUT off and set the chamber temperature to –20°C. After the temperature stabilized for approximately 30 minutes recorded the frequency. 6. Repeat step measure with 10°C increased per stage until the highest temperature of +50°C reached.
Test Instruments:	Refer to section 3 for details
Test mode:	Refer to section 4.1 for details
Test results:	Pass
Remark:	If all frequencies stability are comply with the lower limit, then all results can be considered qualified

Measurement Data

Reference Frequency: LTE Band 5 Middle channel=20175 channel=836.5MHz					
Power supplied (Vdc)	Temperature (°C)	Frequency error		Limit (ppm)	Result
		Hz	ppm		
3.7	-20	18	0.0215	2.5	Pass
	-10	25	0.0298		
	0	25	0.0295		
	10	-26	-0.0305		
	20	19	0.0229		
	30	18	0.0210		
	40	-5	-0.0060		
	50	14	0.0168		
	60	15	0.0179		

Reference Frequency: LTE Band 7 Middle channel=21100 channel=2535MHz					
Power supplied (Vdc)	Temperature (°C)	Frequency error		Limit (ppm)	Result
		Hz	ppm		
3.7	-20	18	0.0072	Within the authorized bands	Pass
	-10	24	0.0096		
	0	25	0.0098		
	10	-29	-0.0114		
	20	23	0.0090		
	30	14	0.0054		
	40	-10	-0.0038		
	50	10	0.0040		
	60	14	0.0054		

Reference Frequency: LTE Band 41 Middle channel=21100 channel=2535MHz					
Power supplied (Vdc)	Temperature (°C)	Frequency error		Limit (ppm)	Result
		Hz	ppm		
3.7	-20	20	0.0080	Within the authorized bands	Pass
	-10	22	0.0087		
	0	20	0.0077		
	10	-25	-0.0099		
	20	19	0.0075		
	30	13	0.0050		
	40	-2	-0.0008		
	50	11	0.0042		
	60	13	0.0050		

4.11 Frequency stability V.S. Voltage measurement

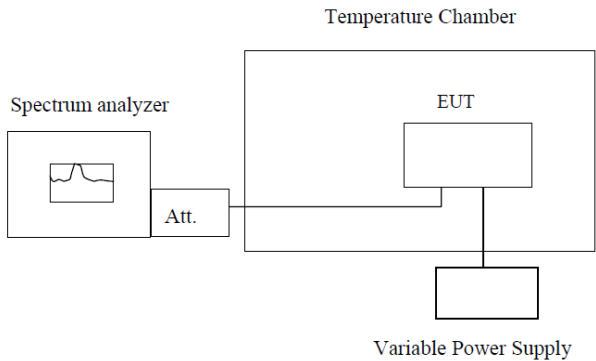
Test Requirement:	FCC Part2.1055(d)(1)(2), FCC part90.213.(a)
Test Method:	ANSI C63.26:2015
Limit:	2.5ppm Band II & Band VII should be within authorized band.
Test setup:	 <p style="text-align: center;">Temperature Chamber</p> <p style="text-align: center;">Spectrum analyzer Att. EUT</p> <p style="text-align: center;">Variable Power Supply</p> <p>Note : Measurement setup for testing on Antenna connector</p>
Test procedure:	<ol style="list-style-type: none"> 1. Set chamber temperature to 20°C. Use a variable DC power source to power the EUT and set the voltage to rated voltage. 2. Set the spectrum analyzer RBW low enough to obtain the desired frequency resolution and recorded the frequency. 3. Reduce the input voltage to specified extreme voltage variation (+/- 15%) and endpoint, record the maximum frequency change.
Test Instruments:	Refer to section 3 for details
Test mode:	Refer to section 4.1 for details
Test results:	Pass
Remark:	<ol style="list-style-type: none"> 1. Manufacturer specified the battery operating end point voltage is 3.32VDC, max voltage is 4.37VDC. 2. If all frequencies stability are comply with the lower limit, then all results can be considered qualified

Measurement Data

Reference Frequency: LTE Band 5 Middle channel=20175 channel=836.5MHz					
Temperature (°C)	Power supplied (Vdc)	Frequency error		Limit (ppm)	Result
		Hz	ppm		
25	4.07	15	0.0179	2.5	Pass
	3.70	21	0.0252		
	3.33	23	0.0272		
Reference Frequency: LTE Band 7 Middle channel=21100 channel=2535MHz					
Temperature (°C)	Power supplied (Vdc)	Frequency error		Limit (ppm)	Result
		Hz	ppm		
25	4.07	20	0.0078	within authorized band	Pass
	3.70	-24	-0.0095		
	3.33	16	0.0063		
Reference Frequency: LTE Band 41 Middle channel=20175 channel=1732.5MHz					
Temperature (°C)	Power supplied (Vdc)	Frequency error		Limit (ppm)	Result
		Hz	ppm		
25	4.07	20	0.0080	2.5	Pass
	3.70	-26	-0.0103		
	3.33	18	0.0069		

4.12 Test Setup Photo

Radiated Emission

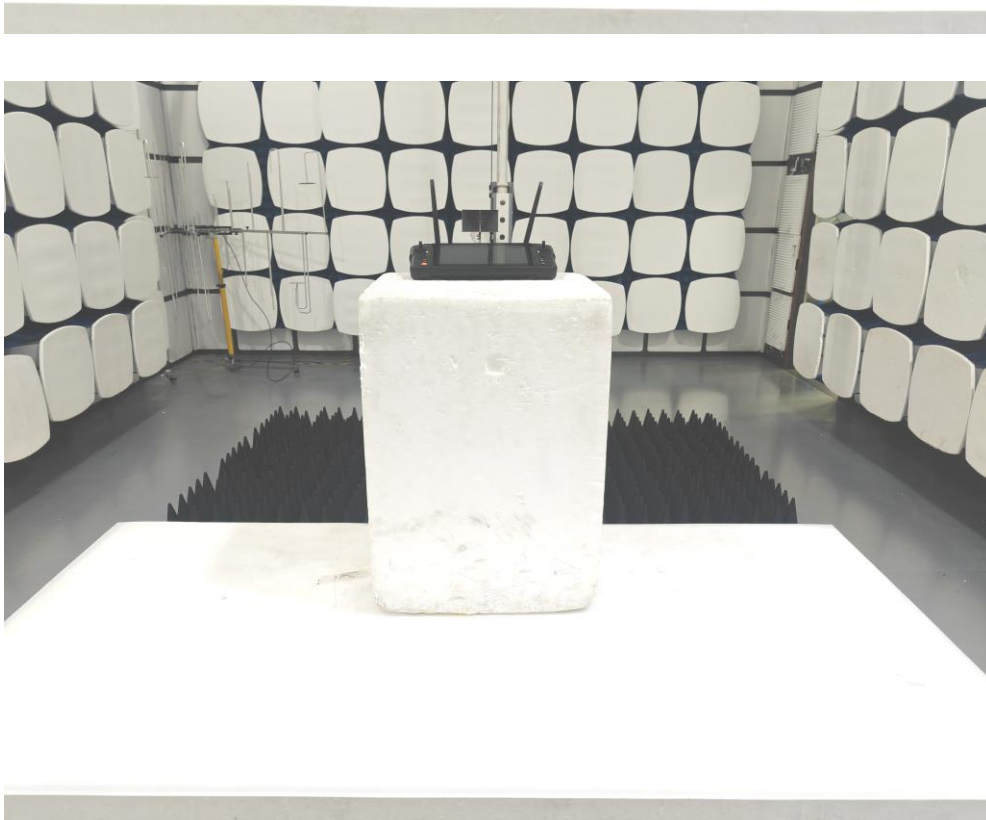
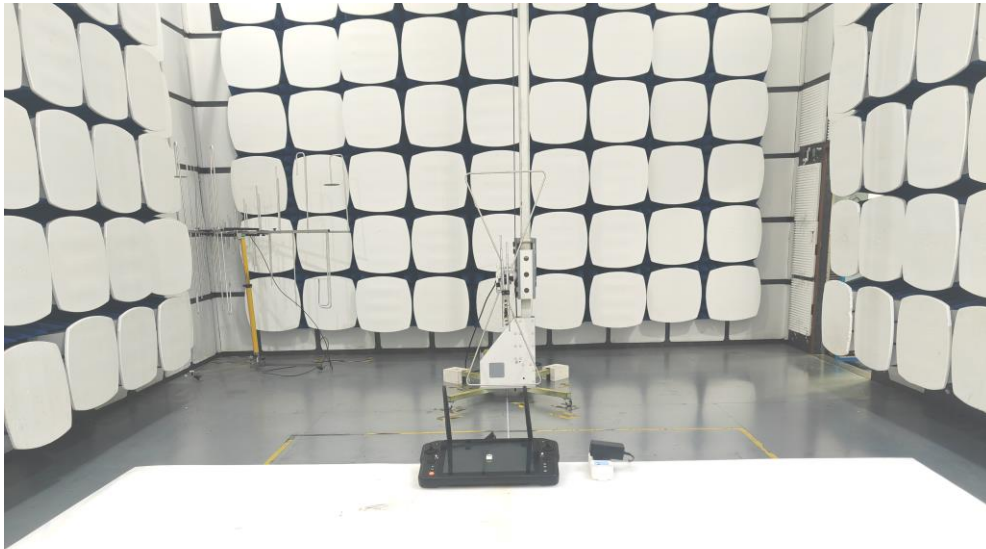

-----END OF REPORT-----