



FCC TEST REPORT

FCC ID: SY4-B01014

On Behalf of

Shanghai Huace Navigation Technology LTD.

Handheld GNSS Data Collector

Model No.: LT700H

Prepared for : Shanghai Huace Navigation Technology LTD.

Address : 599 Gaojing Road, Building D, Shanghai 201702,
China

Prepared By : Shenzhen Alpha Product Testing Co., Ltd.

Address : Building i, No.2, Lixin Road, Fuyong Street, Bao'an
District, 518103, Shenzhen, Guangdong, China

Report Number : A2102055-C01-R07

Date of Receipt : February 27, 2021

Date of Test : February 27-March 25, 2021

Date of Report : April 6, 2021

Version Number : V0

Contents

Page

1	TEST SUMMARY	5
2	GENERAL INFORMATION	6
2.1	GENERAL DESCRIPTION OF EUT	6
2.2	RELATED SUBMITTAL(S) / GRANT (S)	8
2.3	TEST METHODOLOGY	8
2.4	TEST FACILITY	8
3	TEST INSTRUMENTS LIST	9
4	SYSTEM TEST CONFIGURATION	10
4.1	TEST MODE	10
4.2	CONFIGURATION OF TESTED SYSTEM	11
4.3	CONDUCTED PEAK OUTPUT POWER	12
4.4	PEAK-TO-AVERAGE RATIO	14
4.5	OCCUPY BANDWIDTH	15
4.6	MODULATION CHARACTERISTIC	21
4.7	OUT OF BAND EMISSION AT ANTENNA TERMINALS	21
4.8	ERP, EIRP MEASUREMENT	33
4.9	FIELD STRENGTH OF SPURIOUS RADIATION MEASUREMENT	43
4.10	FREQUENCY STABILITY V.S. TEMPERATURE MEASUREMENT	49
4.11	FREQUENCY STABILITY V.S. VOLTAGE MEASUREMENT	53
5	TEST SETUP PHOTO	57
6	EUT CONSTRUCTIONAL DETAILS	58

TEST REPORT DECLARATION

Applicant : Shanghai Huace Navigation Technology LTD.
 Address : 599 Gaojing Road, Building D, Shanghai 201702, China
 Manufacturer : Shanghai Huace Navigation Technology LTD.
 Address : 599 Gaojing Road, Building D, Shanghai 201702, China
 EUT Description : Handheld GNSS Data Collector
 (A) Model No. : LT700H
 (B) Trademark : 

Measurement Standard Used:
FCC CFR Title 47 Part 2
FCC CFR Title 47 Part22 Subpart H
FCC CFR Title 47 Part24 Subpart E

The device described above is tested by Shenzhen Alpha Product Testing Co., Ltd. to determine the maximum emission levels emanating from the device. The maximum emission levels are compared to the FCC Part 15 Subpart C limits both conducted and radiated emissions. The test results are contained in this test report and Shenzhen Alpha Product Testing Co., Ltd. is assumed of full responsibility for the accuracy and completeness of these tests.

After the test, our opinion is that EUT compliance with the requirement of the above standards.

This report applies to above tested sample only. This report shall not be reproduced in parts without written approval of Shenzhen Alpha Product Testing Co., Ltd.

Tested by (name + signature).....: Lucas Pang
 Project Engineer 

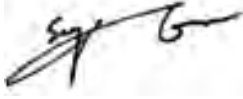
Approved by (name + signature).....: Simple Guan
 Project Manager 

Date of issue.....: April 6, 2021

Revision History

Revision	Issue Date	Revisions	Revised By
V0	April 6, 2021	Initial released Issue	Lucas Pang

1 Test Summary

Test Item	Section in CFR 47	Result
RF Exposure (SAR)	Part 1.1307 Part 2.1093	Pass* (Please refer to SAR Report)
RF Output Power	Part 2.1046 Part 22.913 (a)(2) Part 24.232 (c)	Pass
Peak-to-Average Ratio	Part 2.1046 Part 24.232 (d)	Pass
Modulation Characteristics	Part 2.1047	Pass
99% & -26 dB Occupied Bandwidth	Part 2.1049 Part 22.917 Part 24.238	Pass
Spurious Emissions at Antenna Terminal	Part 2.1051 Part 22.917 (a) Part 24.238 (a)	Pass
Field Strength of Spurious Radiation	Part 2.1053 Part 22.917 (a) Part 24.238 (a)	Pass
Out of band emission, Band Edge	Part 22.917 (a) Part 24.238 (a)	Pass
Frequency stability vs. temperature	Part 2.1055(a)(1)(b)	Pass
Frequency stability vs. voltage	Part 2.1055(d)(1)(2)	Pass

Pass: The EUT complies with the essential requirements in the standard.

2 General Information

2.1 General Description of EUT

Description/PMN : Handheld GNSS Data Collector

Model Number/HVIN(s) : LT700H

Diff : /

Trademark : 

Test Voltage : DC 3.8V from battery, DC 5V for adapter

Support Networks : GPRS, EGPRS, WCDMA

Support Bands : GSM850, PCS1900, WCDMA Band V, WCDMA Band II

TX Frequency : GSM850: 824.20MHz-848.80MHz
 PCS1900: 1850.20MHz-1909.80MHz
 WCDMA Band V: 826.40MHz -846.60MHz
 WCDMA Band II: 1852.40MHz -1907.60MHz

GPRS Class : 12

EGPRS Class : 12

Modulation type : GPRS: GMSK
 EGPRS: GMSK/8PSK
 WCDMA Band II/V: QPSK

Antenna type : Internal antenna

Internal Antenna, Maximum Gain is -1.66dBi for GSM 850
 Internal Antenna, Maximum Gain is 1.95dBi for PCS1900

Antenna gain : Internal Antenna, Maximum Gain is -1.66dBi for WCDMA Band V
 Internal Antenna, Maximum Gain is 1.95dBi for WCDMA Band II

Software version : V1.0

Hardware version/FVIN : V1.0

Remark: The worst-case simultaneous transmission configuration was evaluated with no non-compliance found. Results in this report are only for 2G and 3G function, and there is no other transmitter involved.

Operation Frequency List:

GSM 850		PCS1900		WCDMA Band V		WCDMA Band II	
Channel	Frequency (MHz)	Channel	Frequency (MHz)	Channel	Frequency (MHz)	Channel	Frequency (MHz)
128	824.20	512	1850.20	4132	826.40	9262	1852.40
129	824.40	513	1850.40	4133	826.60	9263	1852.60
· ∴	· ∴	· ∴	· ∴	· ∴	· ∴	· ∴	· ∴
189	836.40	660	1879.80	4181	836.20	9399	1879.80
190	836.60	661	1880.00	4182	836.40	9400	1880.00
191	836.80	662	1880.20	4183	836.60	9401	1880.20
· ∴	· ∴	· ∴	· ∴	· ∴	· ∴	· ∴	· ∴
250	848.60	809	1909.60	4232	846.40	9537	1907.40
251	848.80	810	1909.80	4233	846.60	9538	1907.60

Regards to the operating frequency range over 10 MHz, the Lowest frequency, the middle frequency, and the highest frequency of channel were selected to perform the test, and the selected channel see below:

Final test channel:

GSM 850		PCS1900		WCDMA Band V		WCDMA Band II	
Channel	Frequency (MHz)	Channel	Frequency (MHz)	Channel	Frequency (MHz)	Channel	Frequency (MHz)
128	824.20	512	1850.20	4132	826.40	9262	1852.40
190	836.60	661	1880.00	4183	836.60	9400	1880.00
251	848.80	810	1909.80	4233	846.60	9538	1907.60

2.2 Related Submittal(s) / Grant (s)

This submittal(s) (test report) is filing to comply with Section Part 22 subpart H and Part 24 subpart E of the FCC CFR 47 Rules.

2.3 Test Methodology

Both conducted and radiated testing were performed according to the procedures document on TIA/EIA 603 and FCC CFR 47.1046, 2.1047, 2.1049, 2.1051, 2.1053, 2.1055 and 2.1057

2.4 Test Facility

Shenzhen Alpha Product Testing Co., Ltd
Building i, No.2, Lixin Road, Fuyong Street, Bao'an District, 518103, Shenzhen, Guangdong, China

June 21, 2018 File on Federal Communication Commission
Registration Number: 293961

July 25, 2017 Certificated by IC
Registration Number: CN0085

3 Test Instruments list

Equipment	Manufacture	Model No.	Serial No.	Last cal.	Cal Interval
9*6*6 anechoic chamber	CHENYU	9*6*6	N/A	2019.09.06	3Year
Spectrum analyzer	ROHDE&SCHWARZ	FSV40-N	102137	2020.09.02	1Year
Spectrum analyzer	Agilent	N9020A	MY499100060	2020.09.02	1Year
Receiver	ROHDE&SCHWARZ	ESR	1316.3003K03-102082-Wa	2020.09.02	1Year
Receiver	R&S	ESCI	101165	2020.09.02	1Year
Bilog Antenna	Schwarzbeck	VULB 9168	VULB9168-438	2020.04.12	2Year
Horn Antenna	SCHWARZBECK	BBHA 9120 D	BBHA 9120 D(1201)	2020.04.12	2Year
Active Loop Antenna	SCHWARZBECK	FMZB 1519B	00059	2019.09.07	2Year
Cable	Resenberger	N/A	No.1	2020.09.02	1Year
Cable	Resenberger	N/A	No.2	2020.09.02	1Year
Cable	Resenberger	N/A	No.3	2020.09.02	1Year
Pre-amplifier	HP	HP8347A	2834A00455	2020.09.02	1Year
Pre-amplifier	Agilent	8449B	3008A02664	2020.09.02	1Year
L.I.S.N.#1	Schwarzbeck	NSLK8126	8126466	2020.09.02	1Year
L.I.S.N.#2	ROHDE&SCHWARZ	ENV216	101043	2020.09.02	1 Year
20db Attenuator	ICPROBING	IATS1	82347	2020.09.02	1 Year
Horn Antenna	SCHWARZBECK	BBHA9170	00946	2019.09.07	2 Year
Preamplifier	SKET	LNPA_1840-50	SK2018101801	2020.09.02	1 Year
Power Meter	Agilent	E9300A	MY41496625	2020.09.02	1 Year
Temp. &Humid. Chamber	Weihuang	WHTH-1000-40-880	100631	2020.09.02	1 Year
Switching Mode Power Supply	JUNKE	JK12010S	20140927-6	2020.09.02	1 Year

4 System test configuration

4.1 Test mode

During all testing, EUT is in link mode with base station emulator at maximum power level. The spurious emission measurements were carried out in semi-anechoic chamber with 3-meter test range, and EUT is rotated on three test planes to find out the worst emission.

Test modes		
Band	Radiated	Conducted
GSM 850	<ul style="list-style-type: none"> ■ GSM link ■ GPRS 1 link ■ EPRS 1 link 	<ul style="list-style-type: none"> ■ GSM link ■ GPRS 1 link ■ EGPRS 1 link
PCS 1900	<ul style="list-style-type: none"> ■ GSM link ■ GPRS 1 link ■ EGPRS 1 link 	<ul style="list-style-type: none"> ■ GSM link ■ GPRS 1 link ■ EGPRS 1 link
WCDMA II	<ul style="list-style-type: none"> ■ RMC 12.2Kbps link 	<ul style="list-style-type: none"> ■ RMC 12.2Kbps link
WCDMA Band V	<ul style="list-style-type: none"> ■ RMC 12.2Kbps link 	<ul style="list-style-type: none"> ■ RMC 12.2Kbps link

Note: The maximum power levels are GSM mode for GMSK link, GPRS multi-slot class 8 mode for GMSK link, EGPRS multi-slot class 8 mode for 8PSK link, RMC12.2Kbps mode for WCDMA Band V/II. only these modes were used for all tests.

The conducted power tables are as follows:

Conducted Power (dBm)						
Band	GSM850			PCS1900		
Channel	128	190	251	512	661	810
Frequency	824.20	836.60	848.80	1850.20	1880.00	1909.80
GSM (GMSK, 1 TX slot)	32.77	32.95	32.55	29.04	28.26	29.84
GPRS (GMSK, 1 TX slot)	32.89	33.06	32.43	29.15	28.89	28.32
GPRS (GMSK, 2 TX slot)	32.10	31.98	31.75	29.07	27.72	27.65
GPRS (GMSK, 3 TX slot)	29.75	29.71	30.49	27.23	26.47	25.70
GPRS (GMSK, 4 TX slot)	27.97	28.99	28.91	25.76	25.35	25.51
EGPRS (8PSK, 1 TX slot)	30.28	29.95	30.19	27.57	26.38	25.91
EGPRS (8PSK, 2 TX slot)	29.66	29.81	29.33	25.95	25.92	25.80
EGPRS (8PSK, 3 TX slot)	27.82	27.48	27.44	24.37	23.14	22.55
EGPRS (8PSK, 4 TX slot)	27.43	26.50	26.44	22.64	22.85	22.28

Conducted Power (dBm)						
Band	WCDMA Band II			WCDMA Band V		
Channel	9262	9400	9538	4132	4183	4233
Frequency	1852.4	1880.0	1907.6	826.4	836.6	846.6
RMC 12.2Kbps	19.94	20.23	19.74	22.75	22.28	22.85
HSDPA Subtest-1	19.93	20.37	20.38	21.45	21.62	22.00
HSDPA Subtest-2	19.96	20.46	20.06	21.64	21.16	21.90
HSDPA Subtest-3	20.19	19.79	19.57	21.70	21.84	21.66
HSDPA Subtest-4	19.79	20.19	19.98	22.19	21.97	21.66
HSUPA Subtest-1	20.32	19.89	19.48	21.66	21.58	21.74
HSUPA Subtest-2	20.16	20.41	19.67	22.22	21.09	21.57
HSUPA Subtest-3	20.34	19.89	19.56	22.03	21.48	21.64
HSUPA Subtest-4	20.40	19.88	19.70	22.11	21.33	21.55
HSUPA Subtest-5	20.26	20.65	19.86	21.80	21.42	21.36
AMR	20.05	20.19	19.61	22.02	21.52	22.08

4.2 Configuration of Tested System

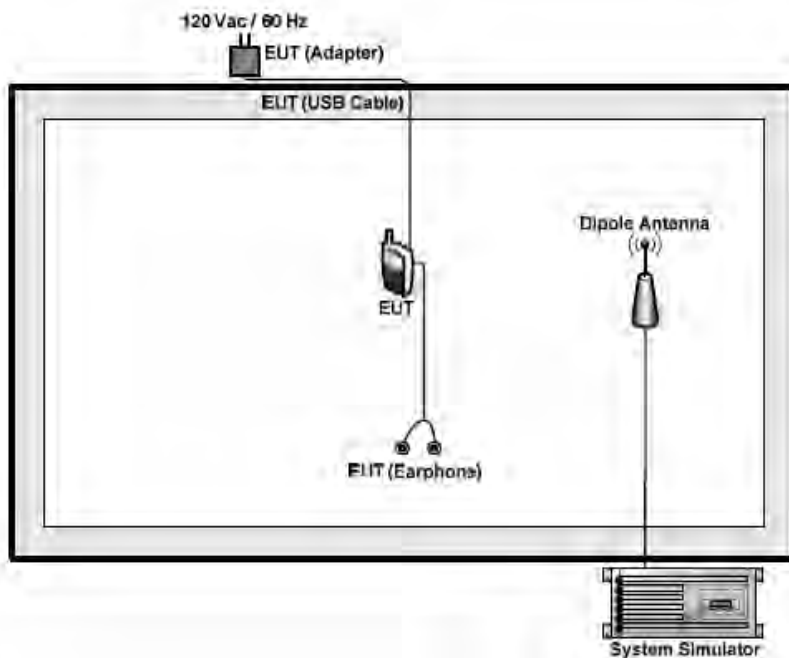

4.3 Conducted AV Output Power

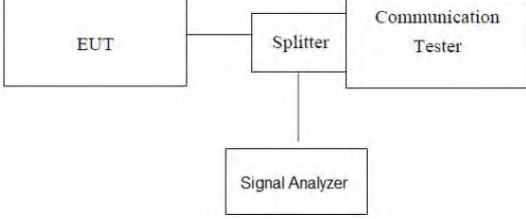
Test Requirement:	FCC part22.913(a) and FCC part24.232(b)
Test Method:	FCC part2.1046
Limit:	GSM850, WCDMA Band V: 7W PCS1900, WCDMA Band II: 2W
Test setup:	 <p style="text-align: center;"><i>Note: Measurement setup for testing on Antenna connector</i></p>
Test Procedure:	<ol style="list-style-type: none"> 1. The transmitter output port was connected to base station. 2. The RF output of EUT was connected to the Signal Analyzer by RF cable and attenuator, the path loss was compensated to the results for each measurement. 3. Set EUT at maximum power through base station. 4. Select lowest, middle, and highest channels for each band and different modulation. 5. Measure the maximum burst average power.
Test Instruments:	Refer to section 5.0 for details
Test mode:	Refer to section 6.1 for details
Test results:	Pass

Measurement Data

Conducted Burst Power (dBm)						
Band	GSM850			PCS1900		
Channel	128	190	251	512	661	810
Frequency	824.20	836.60	848.80	1850.20	1880.00	1909.80
GSM (GMSK, 1 TX slot)	32.12	31.26	32.54	30.12	30.11	30.20
GPRS (GMSK, 1 TX slot)	31.23	30.58	32.38	28.14	28.09	29.19
GPRS (GMSK, 2 TX slot)	30.55	30.25	30.56	27.22	28.20	28.46
GPRS (GMSK, 3 TX slot)	28.26	30.38	28.77	26.99	27.15	28.16
GPRS (GMSK, 4 TX slot)	28.91	30.13	28.76	23.55	24.66	25.26
EGPRS (8PSK, 1 TX slot)	26.58	26.43	27.47	26.66	27.45	26.56
EGPRS (8PSK, 2 TX slot)	24.48	23.59	23.57	24.76	23.52	23.28
EGPRS (8PSK, 3 TX slot)	23.78	25.91	23.42	23.98	23.36	23.55
EGPRS (8PSK, 4 TX slot)	23.31	23.16	23.27	23.16	23.05	23.21

Burst Average Power (dBm)						
Band	WCDMA Band II			WCDMA Band V		
Channel	9262	9400	9538	4132	4183	4233
Frequency	1852.4	1880.0	1907.6	826.4	836.6	846.6
RMC 12.2Kbps	22.99	23.95	23.50	22.94	24.59	22.49
HSDPA Subtest-1	22.31	23.68	22.65	20.31	21.50	20.97
HSDPA Subtest-2	23.70	22.92	22.91	22.12	22.32	21.73
HSDPA Subtest-3	23.18	22.94	22.31	21.25	22.40	22.60
HSDPA Subtest-4	22.36	22.43	24.72	22.14	21.84	20.96
HSUPA Subtest-1	21.03	24.09	23.77	21.04	21.51	22.41
HSUPA Subtest-2	25.10	22.78	23.13	21.28	24.35	22.20
HSUPA Subtest-3	21.99	23.73	21.92	22.23	23.47	22.79
HSUPA Subtest-4	23.57	23.67	22.78	22.99	22.49	21.53
HSUPA Subtest-5	23.67	23.51	23.25	22.36	21.68	23.14

4.4 Peak-to-Average Ratio

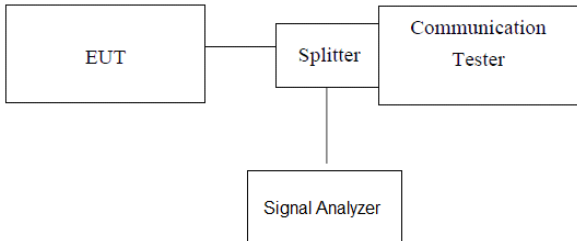
Test Requirement:	FCC part24.232(d)
Test Method:	FCC part2.1046
Limit:	13db
Test setup:	 <p><i>Note: Measurement setup for testing on Antenna connector</i></p>
Test Procedure:	<ol style="list-style-type: none"> 1. The transmitter output port was connected to base station. 2. The RF output of EUT was connected to the Signal Analyzer by RF cable and attenuator, the path loss was compensated to the results for each measurement. 3. Set EUT at maximum power through base station. 4. Select lowest, middle, and highest channels for each band and different modulation. 5. Measure the maximum burst average power. 6. Record the maximum peak-to-average ratio value.
Test Instruments:	Refer to section 5.0 for details
Test mode:	Refer to section 6.1 for details
Test results:	Pass

Measurement data

Test mode	Peak to Average Ratio (dB)			Limit (dB)	Result
	Low Ch.	Middle Ch.	High Ch.		
GSM/TM1/GSM850	9.5	8.83	8.96	13	PASS
GSM/TM1/GSM1900	10.07	9.73	10.25	13	PASS

Test mode	Peak to Average Ratio (dB)			Limit (dB)	Result
	Low Ch.	Middle Ch.	High Ch.		
WCDMA Band II	2.98	3.09	3.03	13	PASS
WCDMA Band V	3.10	3.07	3.06		

4.5 Occupy Bandwidth

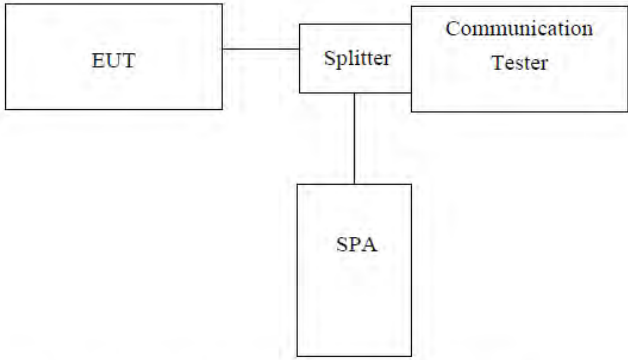
Test Requirement:	FCC part22.913(a) and FCC part24.232(b)
Test Method:	FCC part2.1049
Test setup:	 <pre> graph LR EUT[EUT] --- Splitter[Splitter] Splitter --- CT[Communication Tester] Splitter --- SPA[SPA] </pre> <p><i>Note: Measurement setup for testing on Antenna connector</i></p>
Test Procedure:	<ol style="list-style-type: none"> 1. The EUT's output RF connector was connected with a short cable to the spectrum analyzer 2. RBW was set to about 1% of emission BW, VBW= 3 times RBW. 3. -26dBc display line was placed on the screen (or 99% bandwidth), the occupied bandwidth is the delta frequency between the two points where the display line intersects the signal trace.
Test Instruments:	Refer to section 5.0 for details
Test mode:	Refer to section 6.1 for details
Test results:	Pass

Measurement Data

EUT Mode	Channel	Frequency (MHz)	99% Occupy bandwidth (KHz)	-26dB bandwidth (KHz)
GSM 850 (GSM link)	128	824.20	245.09	305.9
	190	836.60	248.96	310.5
	251	848.80	239.88	305.4
GSM 850 (GPRS 1 link)	128	824.20	242.83	314.9
	190	836.60	242.11	315.5
	251	848.80	244.80	312.9
GSM 850 (EGPRS 1 link)	128	824.20	244.73	321.3
	190	836.60	245.58	316.8
	251	848.80	244.64	312.4
PCS 1900 (GSM link)	512	1850.20	247.14	317.4
	661	1880.00	240.59	313.7
	810	1909.80	246.10	317.9
PCS 1900 (GPRS 1 link)	512	1850.20	244.44	311.7
	661	1880.00	243.08	310.7
	810	1909.80	250.03	319.6
PCS 1900 (EGPRS 1 link)	512	1850.20	245.84	314.0
	661	1880.00	245.63	318.9
	810	1909.80	243.33	313.2
WCDMA Band V (RMC 12.2Kbps link)	4132	826.40	4131.0	4717.00
	4183	836.60	4096.6	4686.00
	4233	846.60	4103.6	4694.00
WCDMA Band II (RMC 12.2Kbps link)	9262	1852.4	4124.9	4709.00
	9400	1880.0	4145.2	4715.00
	9538	1907.6	4125.7	4683.00

Test plot as follows:

GSM 850 (GSM link)	GSM 850 (GPRS 1 link)
--------------------	-----------------------



Lowest channel



Lowest channel



Middle channel



Middle channel



Highest channel



Highest channel

GSM 850 (EGPRS 1 link)	PCS 1900 (GSM link)
------------------------	---------------------



Lowest channel

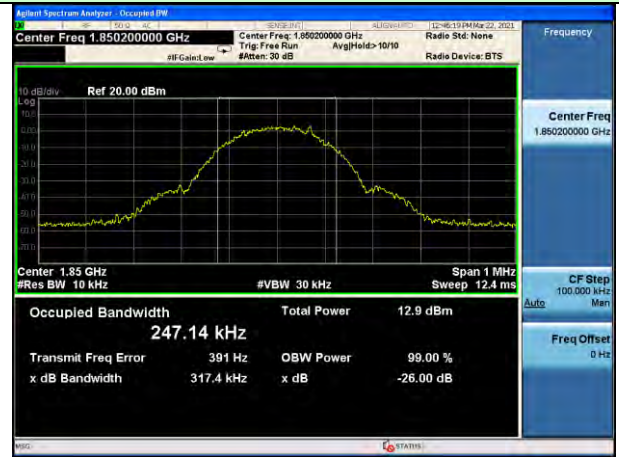

Lowest channel



Middle channel



Middle channel



Highest channel



Highest channel

PCS 1900 (GPRS 1 link) PCS 1900 (EGPRS 1 link)



Lowest channel



Lowest channel



Middle channel



Middle channel



Highest channel



Highest channel

WCDMA Band V (RMC 12.2Kbps link)

WCDMA Band II (RMC 12.2Kbps link)



Lowest channel



Lowest channel



Middle channel

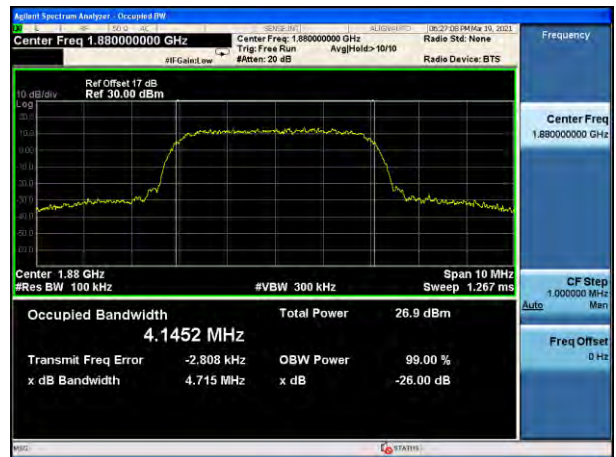

Middle channel

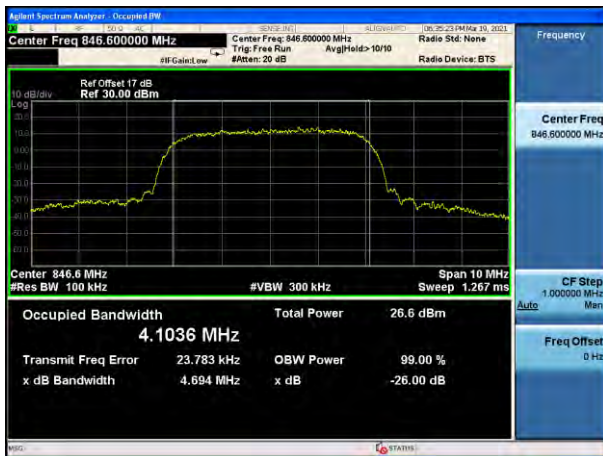

Highest channel



Highest channel

4.6 MODULATION CHARACTERISTIC

According to FCC § 2.1047(d), Part 22H & 24E there is no specific requirement for digital modulation, therefore modulation characteristic is not presented.

4.7 Out of band emission at antenna terminals

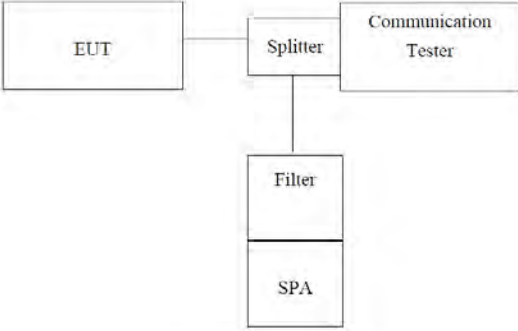
Test Requirement:	FCC part22.917(a) and FCC part24.238(a)
Test Method:	FCC part2.1051
Limit:	-13dBm
Test setup:	 <p><i>Note: Measurement setup for testing on Antenna connector</i></p>
Test Procedure:	<ol style="list-style-type: none"> 1 The RF output of the transceiver was connected to a spectrum analyzer through appropriate attenuation. 2 The resolution bandwidth of the spectrum analyzer was set at 1MHz, sufficient scans were taken to show the out of band Emissions if any up to 10th harmonic. 3 For the out of band: Set the RBW, VBW = 1MHz, Start=30MHz, Stop= 10th harmonic. 4 Band Edge Requirements: In the 1 MHz bands immediately outside and adjacent to the frequency block, a resolution bandwidth of at least 1 percent of the emission bandwidth of the fundamental emission of the transmitter may be employed to measure the out of band Emissions.
Test Instruments:	Refer to section 5.0 for details
Test mode:	Refer to section 6.1 for details
Test results:	Pass

Test plot as follows:

Note: During the conducted spurious emission test, a band filter was used. The information of the filter is reported at section 6.0 (refer to item 24, 25).

Test Mode: Traffic mode GSM 850 (GSM link)

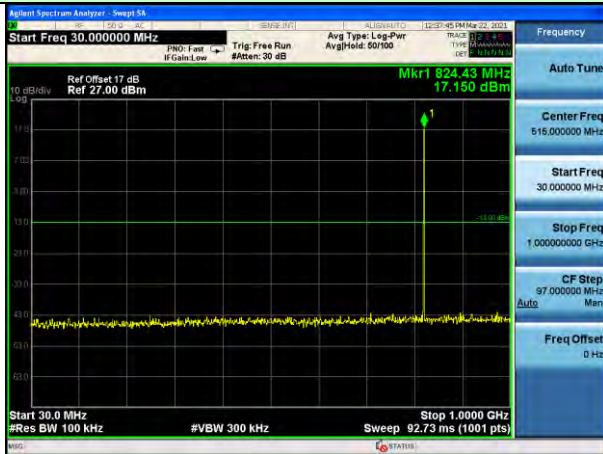

Lowest channel

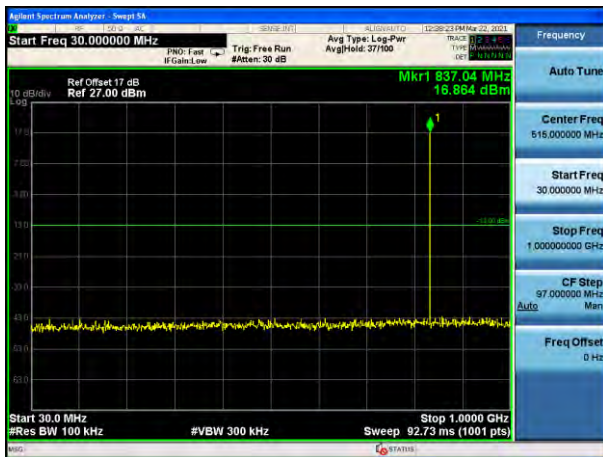

Middle channel

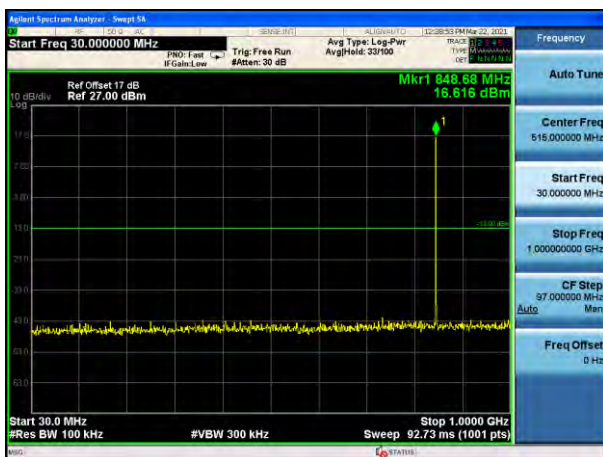

Highest channel

Test Mode: Traffic mode

GSM 850 (GPRS 1 link)

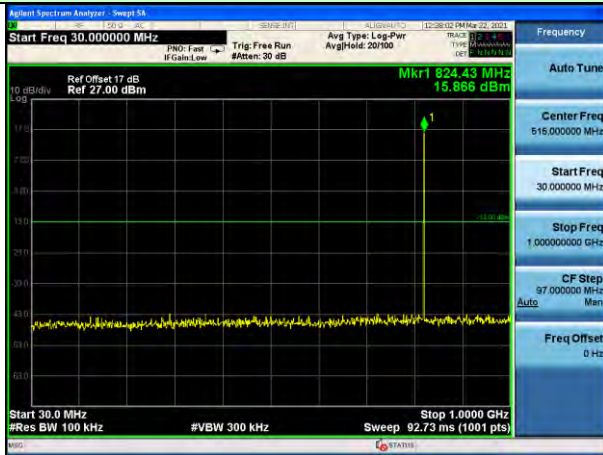

Lowest channel

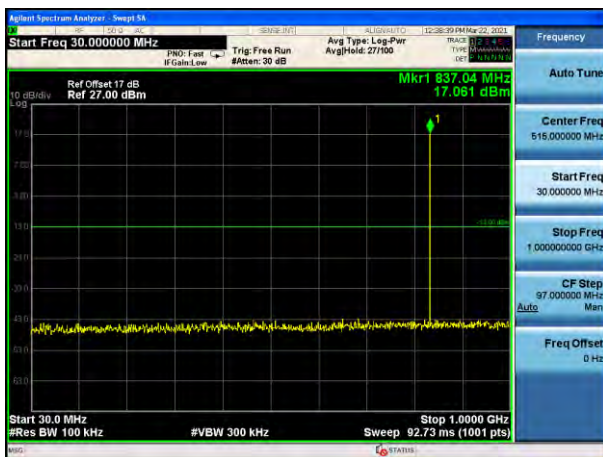

Middle channel

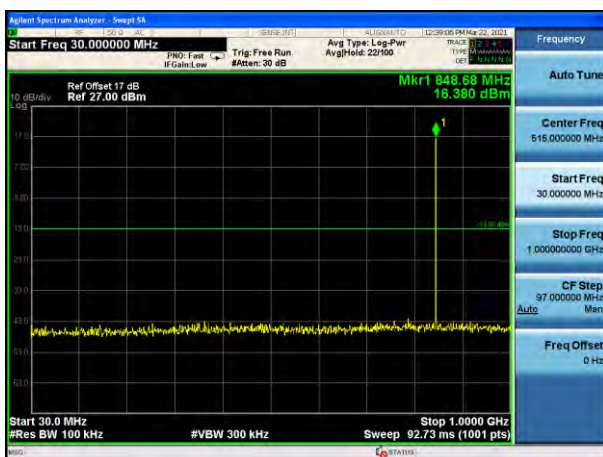

Highest channel

Test Mode: Traffic mode

GSM 850 (EGPRS 1 link)

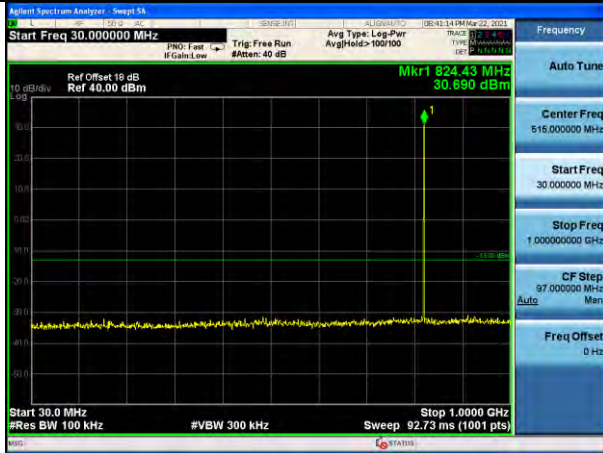

Lowest channel

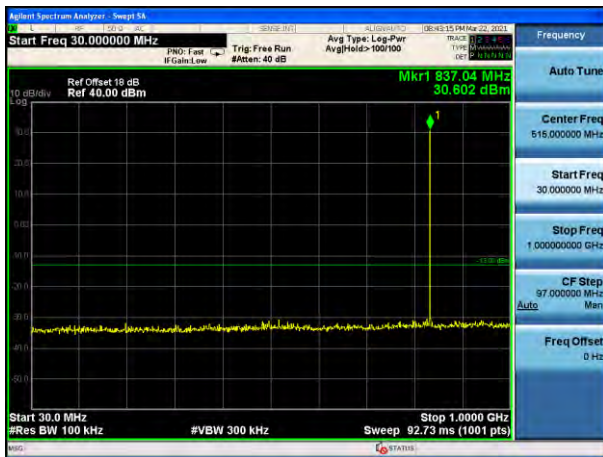

Middle channel

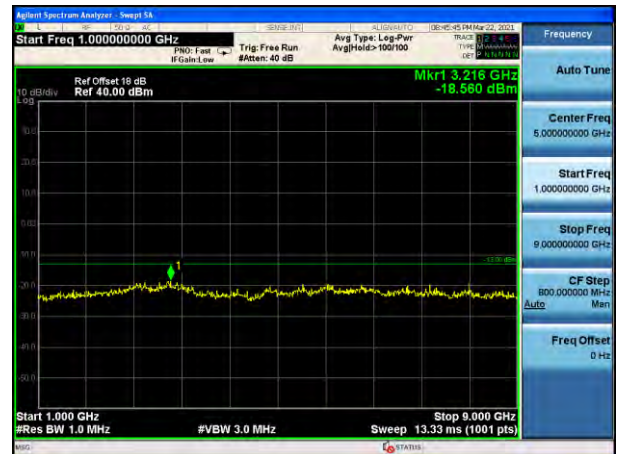
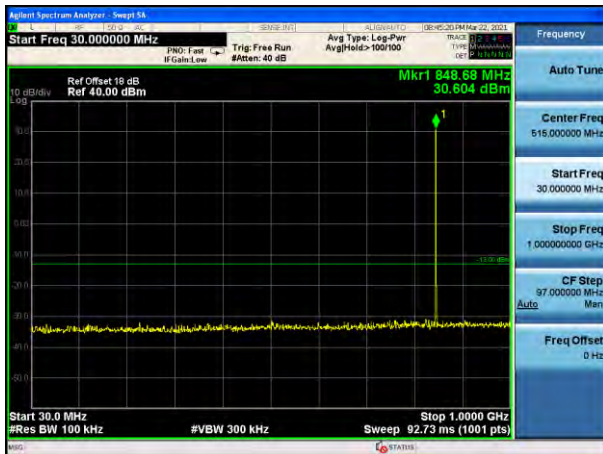

Highest channel

Test Mode: Traffic mode

PCS1900 (GSM link)

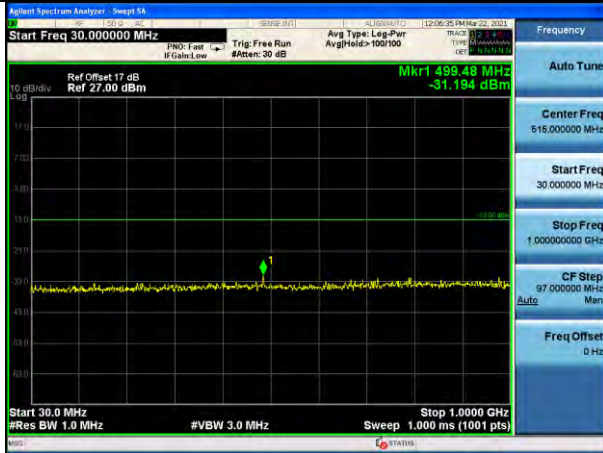

Lowest channel

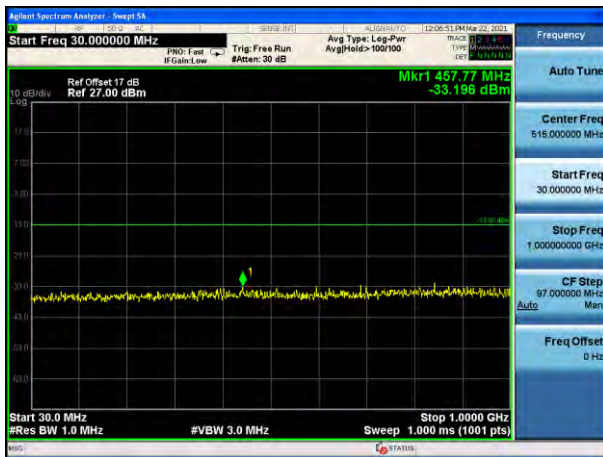

Middle channel



Highest channel

Test Mode: Traffic mode

PCS1900 (GPRS 1 link)

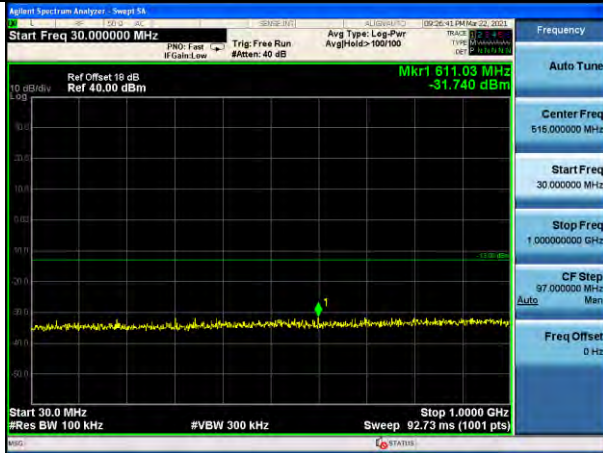

Lowest channel

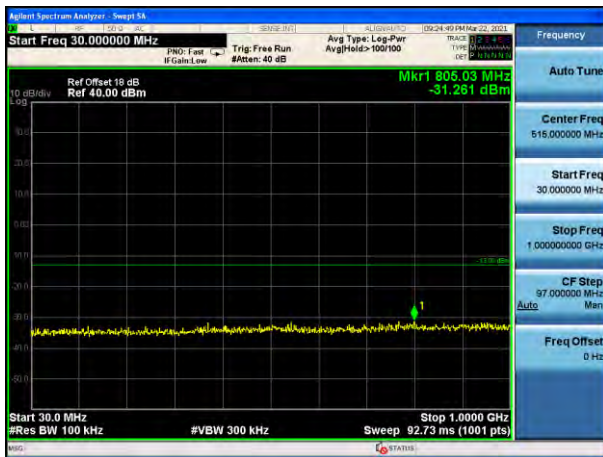

Middle channel



Highest channel

Test Mode: Traffic mode

PCS1900 (EGPRS 1 link)



Lowest channel

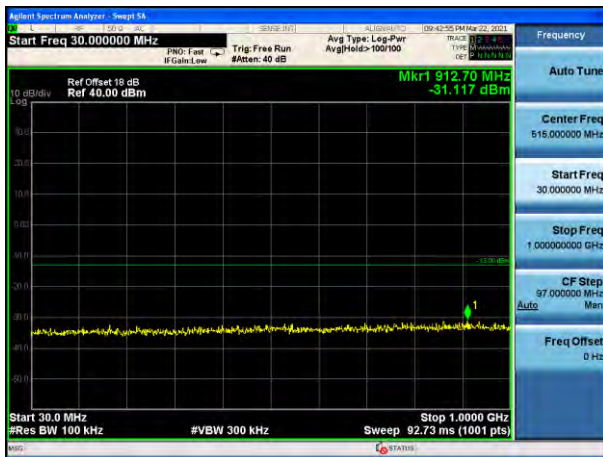

Middle channel

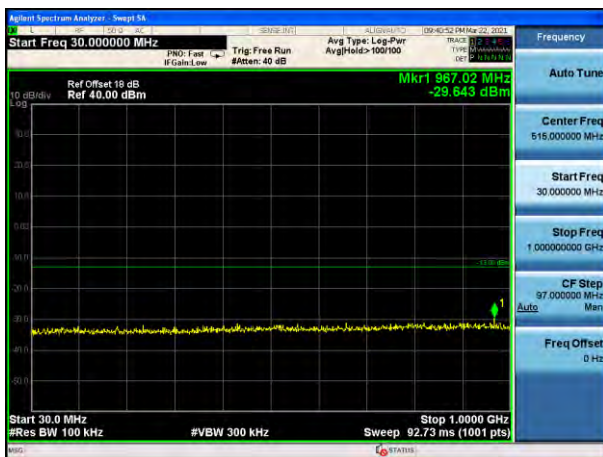

Highest channel

Test Mode: Traffic mode

WCDMA Band V (RMC 12.2Kbps link)

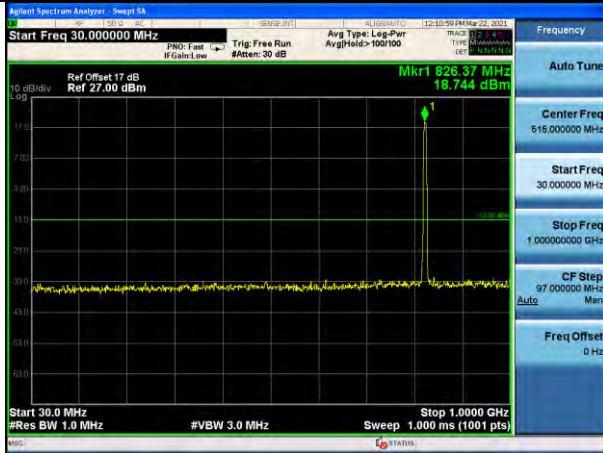

Lowest channel

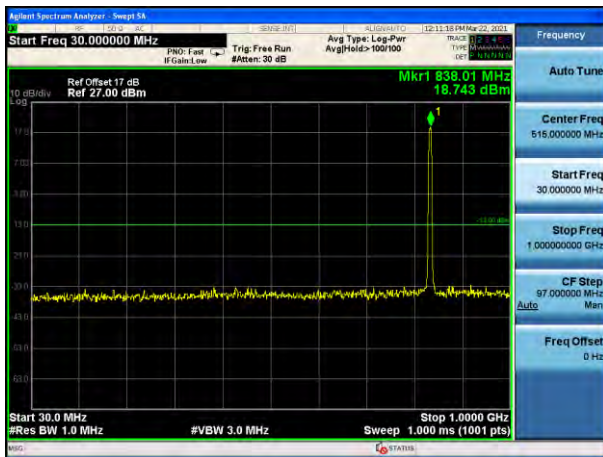

Middle channel

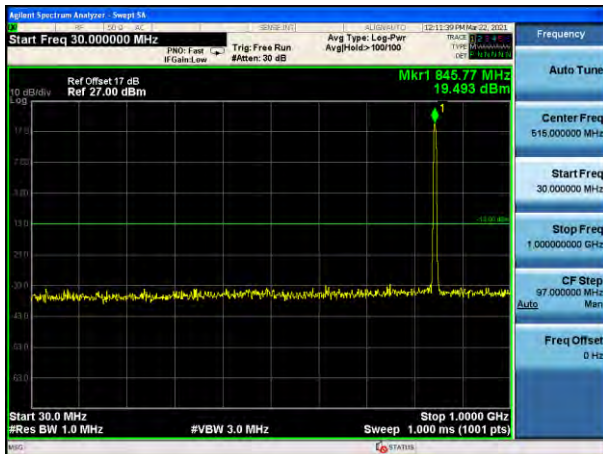

Highest channel

Test Mode: Traffic mode

WCDMA Band II (RMC 12.2Kbps link)



Lowest channel

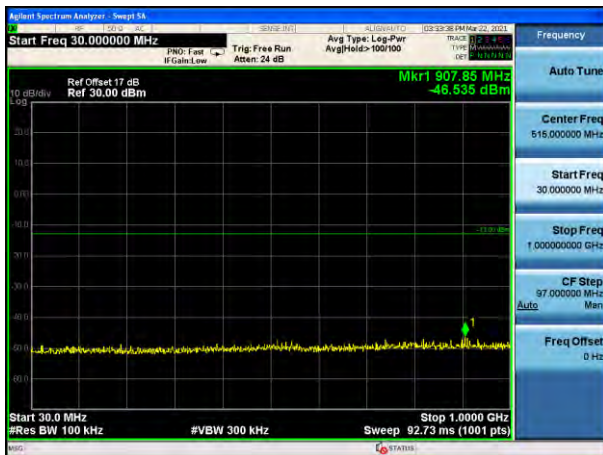

Middle channel

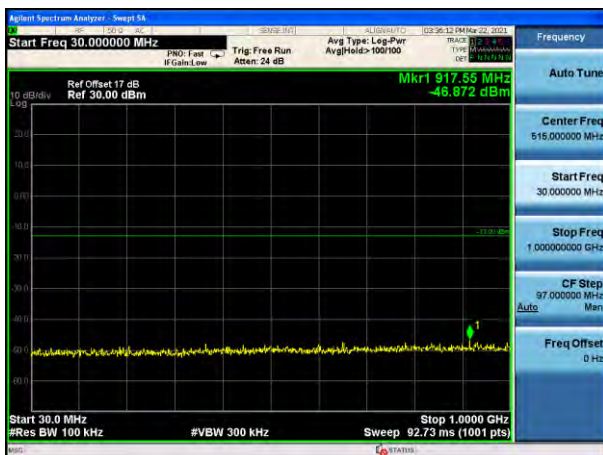

Highest channel

Band Edge:

Test Mode: Traffic mode

GSM850 (GSM link)

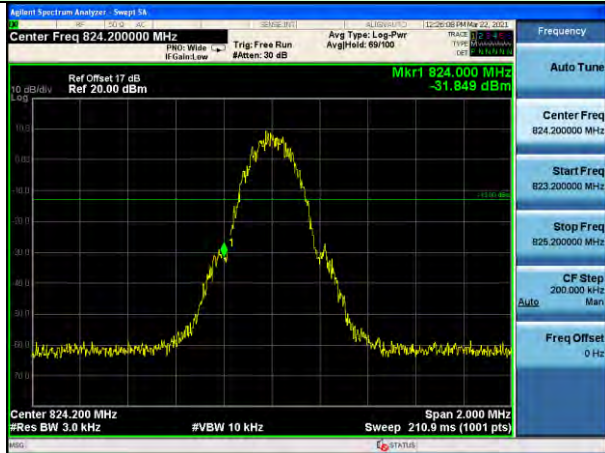

Lowest channel



Highest channel

Test Mode: Traffic mode

GSM850 (GPRS 1 link)

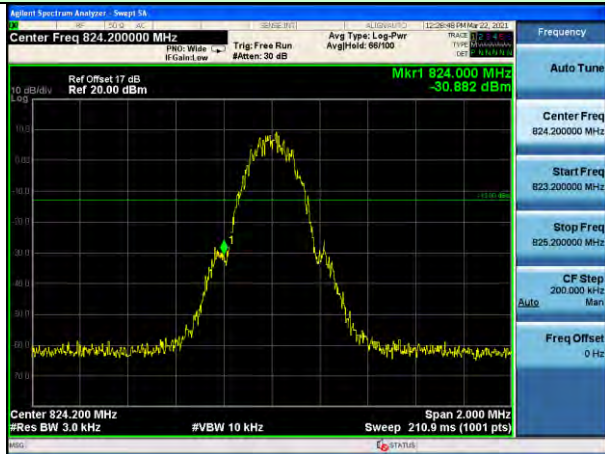

Lowest channel



Highest channel

Test Mode: Traffic mode

GSM850 (EGPRS 1 link)

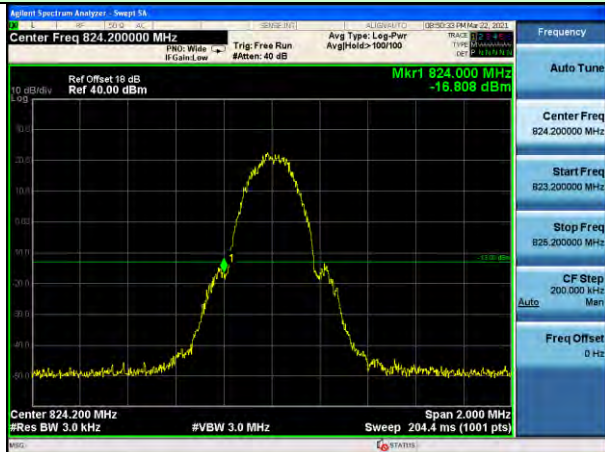

Lowest channel



Highest channel

Test Mode: Traffic mode PCS1900 (GSM link)

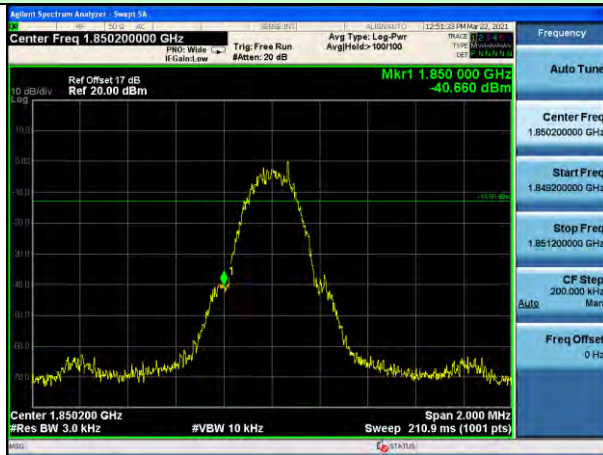

Lowest channel

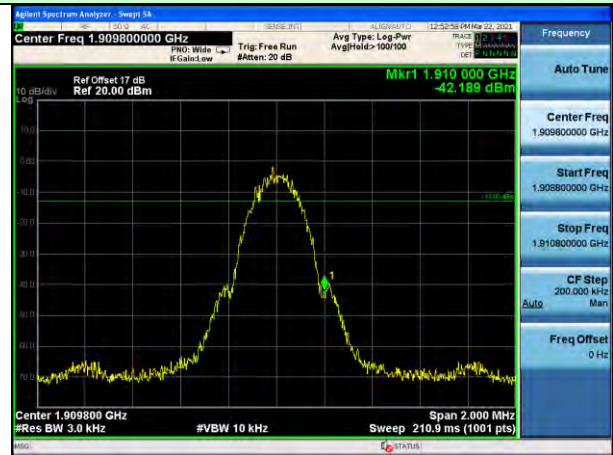

Highest channel

Test Mode: Traffic mode PCS1900 (GPRS 1 link)



Lowest channel



Highest channel

Test Mode: Traffic mode PCS1900 (EGPRS 1 link)

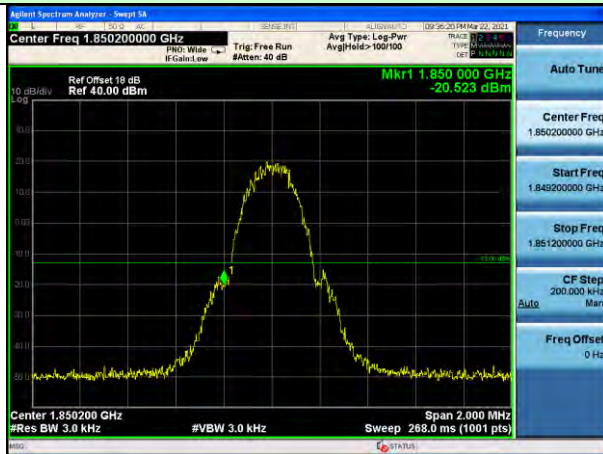

Lowest channel

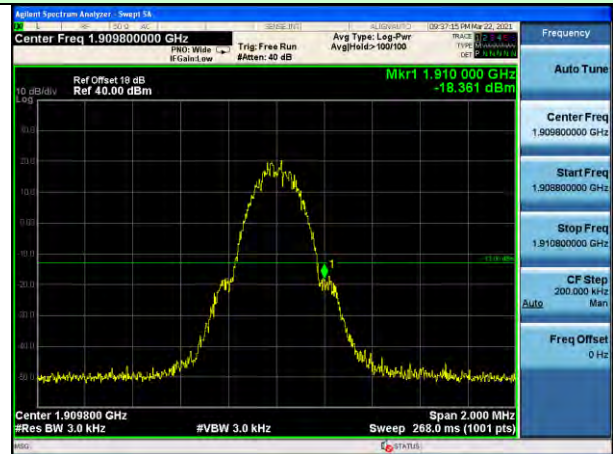

Highest channel

Test Mode: Traffic mode WCDMA Band V (RMC 12.2Kbps link)



Lowest channel



Highest channel

Test Mode: Traffic mode WCDMA Band II (RMC 12.2Kbps link)



Lowest channel



Highest channel

4.8 ERP, EIRP Measurement

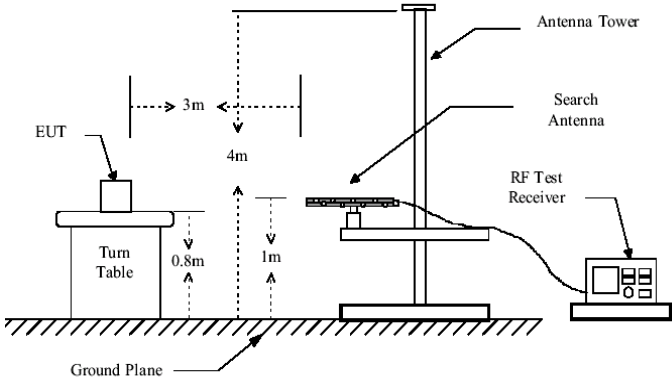
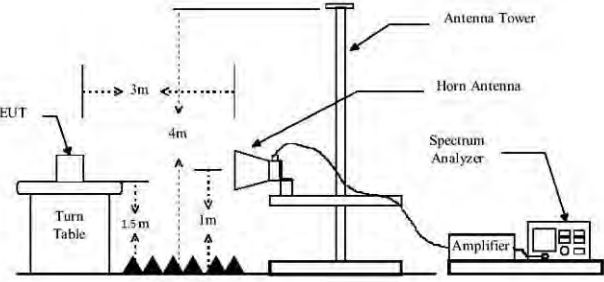
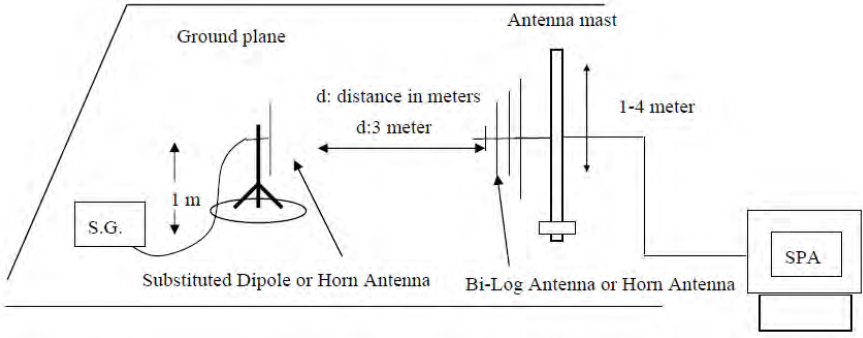
Test Requirement:	FCC part22.913(a) and FCC part24.232(b)
Test Method:	FCC part2.1046
Limit:	GSM850, WCDMA Band V: 7W PCS1900, WCDMA Band II: 2W
Test setup:	<p>Below 1GHz</p>  <p>Above 1GHz</p>  <p>Substituted method:</p> 

Test Procedure:	<ol style="list-style-type: none"> 1. The EUT was placed on an non-conductive turntable using a non-conductive support. The radiated emission at the fundamental frequency was measured at 3 m with a test antenna and EMI spectrum analyzer. 2. During the measurement, the EUT was communication with the station. The highest emission was recorded with the rotation of the turntable and the lowering of the test antenna from 4m to 1m. The reading was recorded and the field strength (E in dBuV/m) was calculated. 3. ERP in frequency band 824.2 –848.80.8MHz were measured using a substitution method. The EUT was replaced by dipole antenna connected, the S.G. output was recorded and ERP was calculated asfollows: $\text{ERP} = \text{S.G. output (dBm)} + \text{Antenna Gain (dBd)} - \text{Cable Loss (dB)}$ 4. EIRP in frequency band 1850.2 –1909.8MHz were measured using a substitution method. The EUT was replaced by or horn antenna connected, the S.G. output was recorded and EIRP was calculated as follows: $\text{EIRP} = \text{S.G. output (dBm)} + \text{Antenna Gain (dBi)} - \text{Cable Loss (dB)}$
Test Instruments:	Refer to section 5.0 for details
Test mode:	Refer to section 6.1 for details
Test results:	Pass

Measurement Data

EUT mode	Channel	EUT Pol.	Antenna Pol.	ERP(dBm)	Limit (dBm)	Result
GSM850 (GSM link)	Lowest	H	V	26.98	38.45	Pass
			H	30.32		
		E1	V	25.60		
			H	29.23		
		E2	V	26.58		
			H	30.38		
	Middle	H	V	26.39	38.45	Pass
			H	30.20		
		E1	V	26.05		
			H	29.94		
		E2	V	25.71		
			H	29.05		
	Highest	H	V	26.01	38.45	Pass
			H	29.96		
		E1	V	26.52		
			H	31.01		
		E2	V	26.48		
			H	26.41		

EUT mode	Channel	EUT Pol.	Antenna Pol.	ERP(dBm)	Limit (dBm)	Result
GSM850 (GPRS 1 link)	Lowest	H	V	26.76	38.45	Pass
			H	30.81		
		E1	V	26.37		
			H	29.57		
		E2	V	26.78		
			H	30.40		
	Middle	H	V	26.78	38.45	Pass
			H	31.04		
		E1	V	26.45		
			H	29.95		
		E2	V	25.81		
			H	29.68		
	Highest	H	V	26.90	38.45	Pass
			H	30.66		
		E1	V	27.13		
			H	30.49		
		E2	V	26.04		
			H	30.63		

EUT mode	Channel	EUT Pol.	Antenna Pol.	ERP(dBm)	Limit (dBm)	Result
GSM850 (EGPRS 1 link)	Lowest	H	V	26.99	38.45	Pass
			H	30.88		
		E1	V	27.61		
			H	30.95		
		E2	V	26.42		
			H	28.97		
	Middle	H	V	26.31	38.45	Pass
			H	30.15		
		E1	V	25.37		
			H	29.61		
		E2	V	25.55		
			H	28.42		
	Highest	H	V	27.50	38.45	Pass
			H	30.44		
		E1	V	27.02		
			H	29.24		
		E2	V	25.36		
			H	28.63		

EUT mode	Channel	EUT Pol.	Antenna Pol.	EIRP (dBm)	Limit (dBm)	Result
PCS1900 (GSM link)	Lowest	H	V	23.78	33.01	Pass
			H	27.21		
		E1	V	23.71		
			H	27.16		
		E2	V	22.89		
			H	26.06		
	Middle	H	V	24.57	33.01	Pass
			H	27.14		
		E1	V	23.93		
			H	27.00		
		E2	V	22.91		
			H	26.14		
	Highest	H	V	25.03	33.01	Pass
			H	27.38		
		E1	V	23.69		
			H	26.48		
		E2	V	23.73		
			H	27.50		

EUT mode	Channel	EUT Pol.	Antenna Pol.	EIRP (dBm)	Limit (dBm)	Result
PCS1900 (GPRS 1 link)	Lowest	H	V	21.27	33.01	Pass
			H	23.95		
		E1	V	20.07		
			H	23.08		
		E2	V	22.78		
			H	26.20		
	Middle	H	V	22.73	33.01	Pass
			H	26.44		
		E1	V	21.94		
			H	24.73		
		E2	V	21.12		
			H	23.71		
	Highest	H	V	23.91	33.01	Pass
			H	27.31		
		E1	V	23.75		
			H	27.26		
		E2	V	22.46		
			H	25.51		

EUT mode	Channel	EUT Pol.	Antenna Pol.	EIRP (dBm)	Limit (dBm)	Result
PCS1900 (EGPRS 1 link)	Lowest	H	V	23.32	33.01	Pass
			H	26.42		
		E1	V	22.65		
			H	25.93		
		E2	V	22.36		
			H	26.55		
	Middle	H	V	22.47	33.01	Pass
			H	26.01		
		E1	V	23.45		
			H	26.06		
		E2	V	22.05		
			H	25.25		
	Highest	H	V	24.11	33.01	Pass
			H	26.49		
		E1	V	24.18		
			H	25.98		
		E2	V	23.29		
			H	26.56		

EUT mode	Channel	EUT Pol.	Antenna Pol.	ERP(dBm)	Limit (dBm)	Result
WCDMA Band V	Lowest	H	V	22.89	38.45	Pass
			H	25.71		
		E1	V	22.45		
			H	26.14		
		E2	V	22.55		
			H	26.21		
	Middle	H	V	22.22	38.45	Pass
			H	26.44		
		E1	V	23.11		
			H	25.51		
		E2	V	21.54		
			H	25.05		
	Highest	H	V	23.51	38.45	Pass
			H	26.90		
		E1	V	23.60		
			H	26.25		
		E2	V	23.99		
			H	26.59		

EUT mode	Channel	EUT Pol.	Antenna Pol.	EIRP(dBm)	Limit (dBm)	Result
WCDMA Band II	Lowest	H	V	23.07	33.01	Pass
			H	25.35		
		E1	V	22.38		
			H	25.56		
		E2	V	22.71		
			H	25.97		
	Middle	H	V	22.24	33.01	Pass
			H	26.20		
		E1	V	22.55		
			H	25.10		
		E2	V	21.60		
			H	24.94		
	Highest	H	V	23.48	33.01	Pass
			H	26.65		
		E1	V	24.25		
			H	26.33		
		E2	V	24.21		
			H	26.83		

4.9 Field strength of spurious radiation measurement

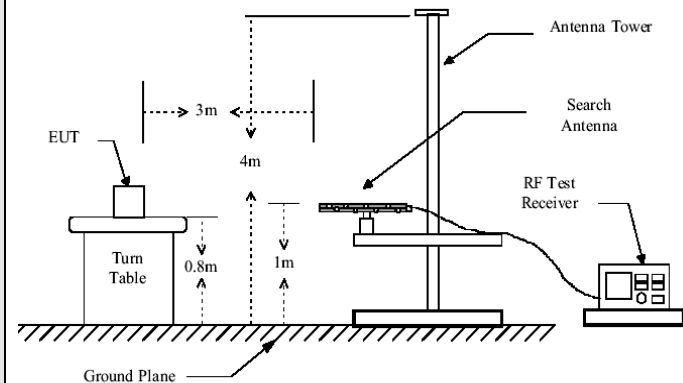
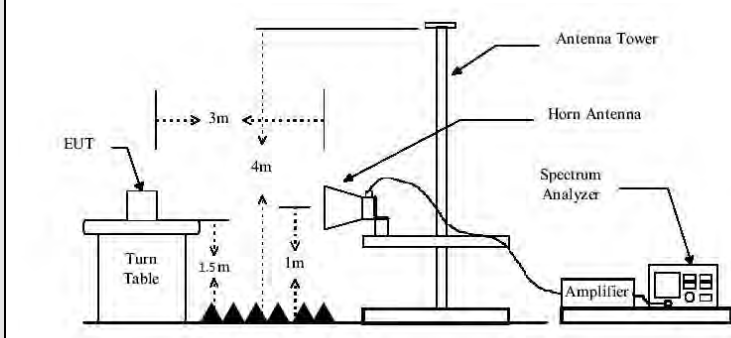
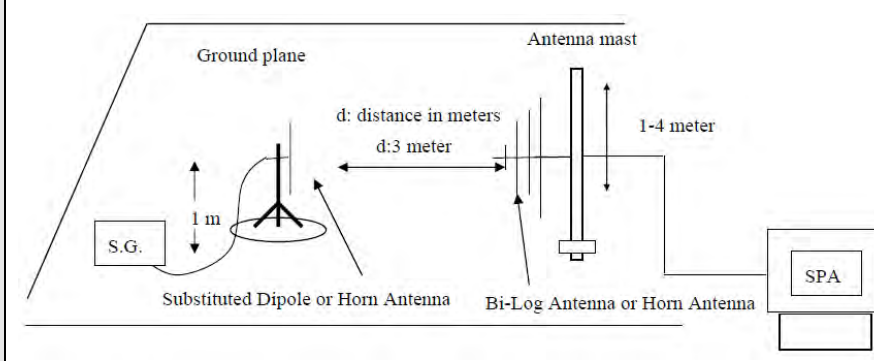
Test Requirement:	FCC part22.917(a) and FCC part24.238(a)
Test Method:	FCC part2.1053
Limit:	-13dBm
Test setup:	<p>Below 1GHz</p>  <p>Above 1GHz</p>  <p>Substituted method:</p> 

Test Procedure:	<ol style="list-style-type: none"> 1. The EUT was placed on a non-conductive turntable using a non-conductive support. The radiated emission at the fundamental frequency was measured at 3 m with a test antenna and EMI spectrum analyzer. 2. During the tests, the antenna height and the EUT azimuth were varied in order to identify the maximum level of emissions from the EUT. This maximization process was repeated with the EUT positioned in each of its three orthogonal orientations. 3. The frequency range up to tenth harmonic was investigated for each of three fundamental frequency (low, middle and high channels). Once spurious emission was identified, the power of the emission was determined using the substitution method. 4. The spurious emissions attenuation was calculated as the difference between radiated power at the fundamental frequency and the spurious emissions frequency. $\text{ERP / EIRP} = \text{S.G. output (dBm)} + \text{Antenna Gain(dB/dBi)} - \text{Cable Loss (dB)}$
Test Instruments:	Refer to section 5.0 for details
Test mode:	Refer to section 6.1 for details
Test results:	Pass

Measurement Data

Test mode:	GSM850		Test channel:	Lowest
Frequency (MHz)	Spurious Emission		Limit (dBm)	Result
	Polarization	Level (dBm)		
1648.40	Vertical	-36.80	-13.00	Pass
2472.60	V	-39.45		
3296.80	V	-38.00		
4121.00	V	-43.31		
4945.20	V	---		
1648.40	Horizontal	-39.08	-13.00	Pass
2472.60	H	-42.57		
3296.80	H	-44.87		
4121.00	H	-45.99		
4945.20	H	---		
Test mode:	GSM850		Test channel:	Middle
Frequency (MHz)	Spurious Emission		Limit (dBm)	Result
	Polarization	Level (dBm)		
1673.20	Vertical	-36.84	-13.00	Pass
2509.80	V	-39.50		
3346.40	V	-38.69		
4183.00	V	-42.84		
5019.60	V	---		
1673.20	Horizontal	-39.44	-13.00	Pass
2509.80	H	-42.96		
3346.40	H	-44.33		
4183.00	H	-45.97		
5019.60	H	---		
Test mode:	GSM850		Test channel:	Highest
Frequency (MHz)	Spurious Emission		Limit (dBm)	Result
	Polarization	Level (dBm)		
1697.60	Vertical	-36.41	-13.00	Pass
2546.40	V	-39.12		
3395.20	V	-38.27		
4244.00	V	-42.93		
5092.80	V	---		
1697.60	Horizontal	-39.39	-13.00	Pass
2546.40	H	-42.67		
3395.20	H	-44.74		
4244.00	H	-45.37		
5092.80	H	---		

Remark :

1. The emission behaviour belongs to narrowband spurious emission.
2. Remark"---" means that the emission level is too low to be measured
3. The emission levels of below 1 GHz are very lower than the limit and not show in test report.

Test mode:	PCS1900		Test channel:	Lowest
Frequency (MHz)	Spurious Emission		Limit (dBm)	Result
	Polarization	Level (dBm)		
3700.40	Vertical	-36.86	-13.00	Pass
5550.60	V	-39.63		
7400.80	V	-38.64		
9251.00	V	-43.00		
11101.20	V	---		
3700.40	Horizontal	-39.09	-13.00	Pass
5550.60	H	-42.80		
7400.80	H	-44.89		
9251.00	H	-46.16		
11101.20	H	---		
Test mode:	PCS1900		Test channel:	Middle
Frequency (MHz)	Spurious Emission		Limit (dBm)	Result
	Polarization	Level (dBm)		
3760.00	Vertical	-36.64	-13.00	Pass
5640.00	V	-39.16		
7520.00	V	-38.71		
9400.00	V	-43.55		
11280.00	V	---		
3760.00	Horizontal	-39.41	-13.00	Pass
5640.00	H	-42.96		
7520.00	H	-44.26		
9400.00	H	-45.43		
11280.00	H	---		
Test mode:	PCS1900		Test channel:	Highest
Frequency (MHz)	Spurious Emission		Limit (dBm)	Result
	Polarization	Level (dBm)		
3819.60	Vertical	-37.01	-13.00	Pass
5729.40	V	-39.53		
7639.20	V	-38.76		
9549.00	V	-43.04		
11458.80	V	---		
3819.60	Horizontal	-38.84	-13.00	Pass
5729.40	H	-43.29		
7639.20	H	-44.91		
9549.00	H	-46.18		
11458.80	H	---		

Remark:

1. The emission behaviour belongs to narrowband spurious emission.
2. Remark"---" means that the emission level is too low to be measured
3. The emission levels of below 1 GHz are very lower than the limit and not show in test report.

Test mode:		WCDMA Band V		Test channel:	Lowest
Frequency (MHz)	Spurious Emission		Limit (dBm)	Result	
	Polarization	Level (dBm)			
1652.80	Vertical	-36.16	-13.00	Pass	
2479.20	V	-39.20			
3305.60	V	-38.59			
4132.00	V	-43.46			
4958.40	V	---			
1652.80	Horizontal	-39.48	-13.00	Pass	
2479.20	H	-43.15			
3305.60	H	-44.74			
4132.00	H	-46.10			
4958.40	H	---			
Test mode:		WCDMA Band V		Test channel:	Middle
Frequency (MHz)	Spurious Emission		Limit (dBm)	Result	
	Polarization	Level (dBm)			
1672.80	Vertical	-36.83	-13.00	Pass	
2509.20	V	-38.94			
3345.60	V	-38.27			
4182.00	V	-43.02			
5018.40	V	---			
1672.80	Horizontal	-39.05	-13.00	Pass	
2509.20	H	-42.99			
3345.60	H	-44.19			
4182.00	H	-46.21			
5018.40	H	---			
Test mode:		WCDMA Band V		Test channel:	Highest
Frequency (MHz)	Spurious Emission		Limit (dBm)	Result	
	Polarization	Level (dBm)			
1693.20	Vertical	-37.08	-13.00	Pass	
2539.80	V	-39.27			
3386.40	V	-41.85			
4233.00	V	-45.39			
5079.60	V	---			
1693.20	Horizontal	-40.45	-13.00	Pass	
2539.80	H	-43.31			
3386.40	H	-44.66			
4233.00	H	-50.54			
5079.60	H	---			

Remark :

1. The emission behaviour belongs to narrowband spurious emission.
2. Remark"---" means that the emission level is too low to be measured
3. The emission levels of below 1 GHz are very lower than the limit and not show in test report.

Test mode:	WCDMA Band II		Test channel:	Lowest
Frequency (MHz)	Spurious Emission		Limit (dBm)	Result
	Polarization	Level (dBm)		
3704.80	Vertical	-38.79	-13.00	Pass
5557.20	V	-41.36		
7409.60	V	-44.15		
9262.00	V	-46.75		
11114.40	V	---		
3704.80	Horizontal	-44.07	-13.00	Pass
5557.20	H	-48.41		
7409.60	H	-50.66		
9262.00	H	-53.65		
11114.40	H	---		
Test mode:	WCDMA Band II		Test channel:	Middle
Frequency (MHz)	Spurious Emission		Limit (dBm)	Result
	Polarization	Level (dBm)		
3760.00	Vertical	-38.49	-13.00	Pass
5640.00	V	-41.57		
7520.00	V	-44.47		
9400.00	V	-46.85		
11280.00	V	---		
3760.00	Horizontal	-43.89	-13.00	Pass
5640.00	H	-48.92		
7520.00	H	-50.48		
9400.00	H	-53.07		
11280.00	H	---		
Test mode:	WCDMA Band II		Test channel:	Highest
Frequency (MHz)	Spurious Emission		Limit (dBm)	Result
	Polarization	Level (dBm)		
3815.20	Vertical	-37.90	-13.00	Pass
5722.80	V	-41.28		
7630.40	V	-43.87		
9538.00	V	-46.25		
11445.60	V	---		
3815.20	Horizontal	-44.46	-13.00	Pass
5722.80	H	-48.90		
7630.40	H	-49.88		
9538.00	H	-53.16		
11445.60	H	---		

Remark:

1. The emission behaviour belongs to narrowband spurious emission.
2. Remark"---" means that the emission level is too low to be measured
3. The emission levels of below 1 GHz are very lower than the limit and not show in test report.

4.10 Frequency stability V.S. Temperature measurement

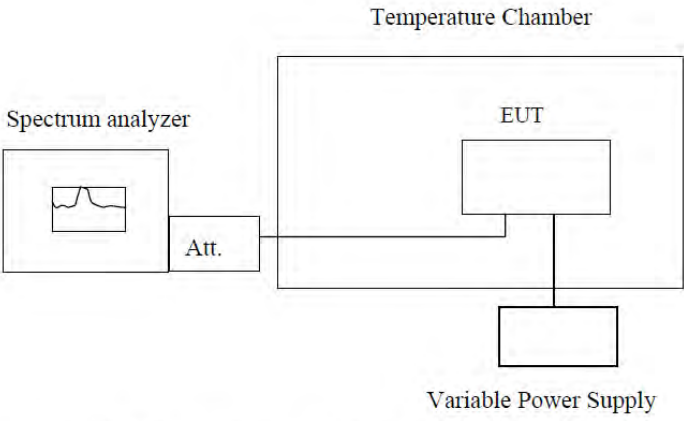
Test Requirement:	FCC Part2.1055(a)(1)(b)
Test Method:	FCC Part2.1055(a)(1)(b)
Limit:	2.5ppm
Test setup:	 <p style="text-align: center;">Note : Measurement setup for testing on Antenna connector</p>
Test procedure:	<ol style="list-style-type: none"> 1. The equipment under test was connected to an external DC power supply and input rated voltage. 2. RF output was connected to a frequency counter or spectrum analyzer via feed through attenuators. 3. The EUT was placed inside the temperature chamber. 4. Set the spectrum analyzer RBW low enough to obtain the desired frequency resolution and measure EUT 25°C operating frequency as reference frequency. 5. Turn EUT off and set the chamber temperature to –20°C . After the temperature stabilized for approximately 30 minutes recorded the frequency. 6. Repeat step measure with 10°C increased per stage until the highest temperature of +50°C reached.
Test Instruments:	Refer to section 5.0 for details
Test mode:	Refer to section 6.1 for details
Test results:	Pass

Measurement Data

Reference Frequency: GSM850 (GSM link) Middle channel=190 channel=836.6MHz					
Power supplied (Vdc)	Temperature (°C)	Frequency error		Limit (ppm)	Result
		Hz	ppm		
3.80	-30	40	0.0478	2.5	Pass
	-20	23	0.0275		
	-10	29	0.0351		
	0	31	0.0367		
	10	33	0.0389		
	20	28	0.0338		
	30	53	0.0629		
	40	43	0.0514		
	50	31	0.0376		
Reference Frequency: GSM850 (GPRS 1 link) Middle channel=190 channel=836.6MHz					
Power supplied (Vdc)	Temperature (°C)	Frequency error		Limit (ppm)	Result
		Hz	ppm		
3.80	-30	38	0.0451	2.5	Pass
	-20	23	0.0275		
	-10	34	0.0404		
	0	34	0.0409		
	10	34	0.0401		
	20	29	0.0346		
	30	50	0.0594		
	40	40	0.0477		
	50	32	0.0383		
Reference Frequency: GSM850 (EGPRS 1 link) Middle channel=190 channel=836.6MHz					
Power supplied (Vdc)	Temperature (°C)	Frequency error		Limit (ppm)	Result
		Hz	ppm		
3.80	-30	35	0.0418	2.5	Pass
	-20	23	0.0275		
	-10	30	0.0364		
	0	31	0.0376		
	10	35	0.0413		
	20	26	0.0305		
	30	51	0.0605		
	40	42	0.0497		
	50	37	0.0438		

Reference Frequency: PCS1900 (GSM link) Middle channel=661 channel=1880MHz					
Power supplied (Vdc)	Temperature (°C)	Frequency error			Result
		Hz	ppm		
3.80	-30	31	0.0163	2.5	Pass
	-20	23	0.0122		
	-10	35	0.0186		
	0	26	0.0138		
	10	30	0.0162		
	20	37	0.0195		
	30	56	0.0299		
	40	45	0.0241		
	50	42	0.0223		
Reference Frequency: PCS1900 (GPRS 1 link) Middle channel=661 channel=1880MHz					
Power supplied (Vdc)	Temperature (°C)	Frequency error			Result
		Hz	ppm		
3.80	-30	38	0.0205	2.5	Pass
	-20	49	0.0261		
	-10	40	0.0214		
	0	35	0.0188		
	10	36	0.0192		
	20	29	0.0157		
	30	54	0.0289		
	40	40	0.0211		
	50	42	0.0226		
Reference Frequency: PCS1900 (EGPRS 1 link) Middle channel=661 channel=1880MHz					
Power supplied (Vdc)	Temperature (°C)	Frequency error			Result
		Hz	ppm		
3.80	-30	27	0.0145	2.5	Pass
	-20	23	0.0122		
	-10	36	0.0194		
	0	22	0.0117		
	10	31	0.0164		
	20	37	0.0196		
	30	57	0.0301		
	40	42	0.0224		
	50	38	0.0201		

Reference Frequency: WCDMA Band V Middle channel=4183 channel=836.6MHz					
Power supplied (Vdc)	Temperature (°C)	Frequency error		Limit (ppm)	Result
		Hz	ppm		
3.80	-30	90	0.1070	2.5	Pass
	-20	23	0.0275		
	-10	74	0.0880		
	0	72	0.0858		
	10	70	0.0834		
	20	59	0.0707		
	30	67	0.0797		
	40	73	0.0869		
	50	74	0.0879		
Reference Frequency: WCDMA Band II Middle channel=9400 channel=1880.0MHz					
Power supplied (Vdc)	Temperature (°C)	Frequency error		Limit (ppm)	Result
		Hz	ppm		
3.80	-30	89	0.1064	2.5	Pass
	-20	23	0.0275		
	-10	73	0.0867		
	0	68	0.0816		
	10	69	0.0827		
	20	62	0.0736		
	30	67	0.0799		
	40	77	0.0916		
	50	73	0.0870		

4.11 Frequency stability V.S. Voltage measurement

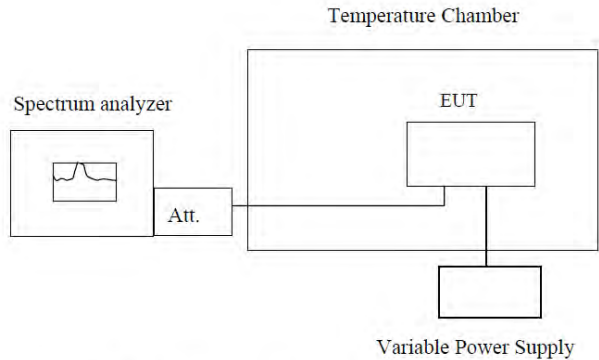
Test Requirement:	FCC Part2.1055(d)(1)(2)
Test Method:	FCC Part2.1055(d)(1)(2)
Limit:	2.5ppm
Test setup:	 <p style="text-align: center;">Temperature Chamber</p> <p style="text-align: center;">Spectrum analyzer</p> <p style="text-align: center;">Att.</p> <p style="text-align: center;">EUT</p> <p style="text-align: center;">Variable Power Supply</p> <p>Note : Measurement setup for testing on Antenna connector</p>
Test procedure:	<ol style="list-style-type: none"> 1. Set chamber temperature to 25°C . Use a variable DC power source to power the EUT and set the voltage to rated voltage. 2. Set the spectrum analyzer RBW low enough to obtain the desired frequency resolution and recorded the frequency. 3. Reduce the input voltage to specified extreme voltage variation (+/- 15%) and endpoint, record the maximum frequency change.
Test Instruments:	Refer to section 5.0 for details
Test mode:	Refer to section 6.1 for details
Test results:	Pass

Measurement Data

Reference Frequency: GSM850 (GSM link) Middle channel=190 channel=836.6MHz					
Temperature (°C)	Power supplied (Vdc)	Frequency error		Limit (ppm)	Result
		Hz	ppm		
25	4.18	55	0.0659	2.5	Pass
	3.8	23	0.0275		
	3.42	66	0.0795		
Reference Frequency: GSM850 (GPRS 1 link) Middle channel=190 channel=836.6MHz					
Temperature (°C)	Power supplied (Vdc)	Frequency error		Limit (ppm)	Result
		Hz	ppm		
25	4.18	34	0.0411	2.5	Pass
	3.8	33	0.0389		
	3.42	20	0.0244		
Reference Frequency: GSM850 (EGPRS 1 link) Middle channel=190 channel=836.6MHz					
Temperature (°C)	Power supplied (Vdc)	Frequency error		Limit (ppm)	Result
		Hz	ppm		
25	4.18	31	0.0367	2.5	Pass
	3.8	29	0.0350		
	3.42	36	0.0428		

Reference Frequency: PCS1900 (GSM link) Middle channel=661 channel=1880MHz					
Temperature (℃)	Power supplied (Vdc)	Frequency error		Limit (ppm)	Result
		Hz	ppm		
25	4.18	58	0.0306	2.5	Pass
	3.8	23	0.0122		
	3.42	69	0.0365		
Reference Frequency: PCS1900 (GPRS 1 link) Middle channel=661 channel=1880MHz					
Temperature (℃)	Power supplied (Vdc)	Frequency error		Limit (ppm)	Result
		Hz	ppm		
25	4.18	35	0.0185	2.5	Pass
	3.8	28	0.0148		
	3.42	24	0.0126		
Reference Frequency: PCS1900 (EGPRS 1 link) Middle channel=661 channel=1880MHz					
Temperature (℃)	Power supplied (Vdc)	Frequency error		Limit (ppm)	Result
		Hz	ppm		
25	4.18	33	0.0175	2.5	Pass
	3.8	30	0.0158		
	3.42	33	0.0178		

Reference Frequency: WCDMA Band V Middle channel=4183 channel=836.6MHz					
Temperature (°C)	Power supplied (Vdc)	Frequency error		Limit (ppm)	Result
		Hz	ppm		
25	4.18	54	0.0643	2.5	Pass
	3.8	23	0.0275		
	3.42	67	0.0805		
Reference Frequency: WCDMA Band II Middle channel=940 channel=1880.0MHz					
Temperature (°C)	Power supplied (Vdc)	Frequency error		Limit (ppm)	Result
		Hz	ppm		
25	4.18	55	0.0294	2.5	Pass
	3.8	23	0.0122		
	3.42	71	0.0376		

5 Test Setup Photo

Radiated Emission

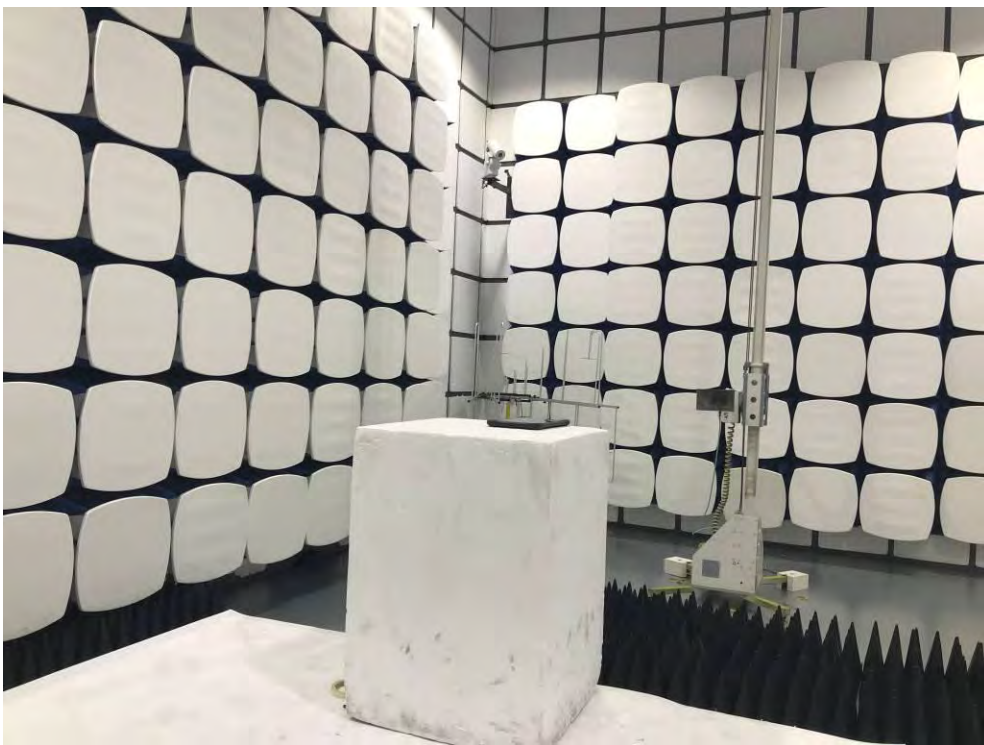
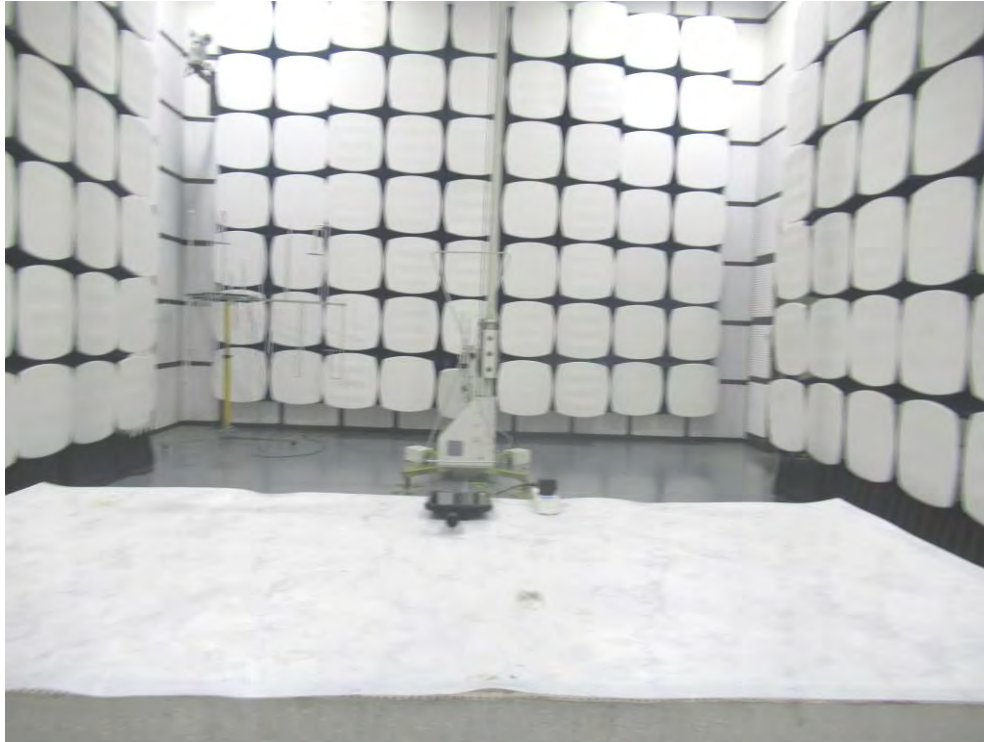

6 EUT Constructional Details

Please refer to report A2102055-C01-R01.

-----End-----