

Test Mode: LTE Band 7 / 20MHz /1RB Test Mode: LTE Band 7 / 20MHz /100RB

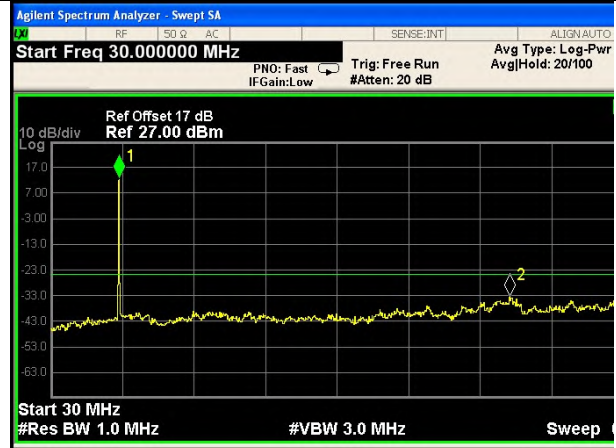

Lowest channel

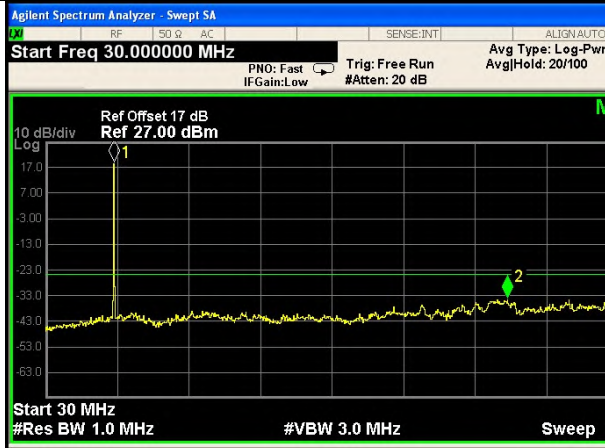
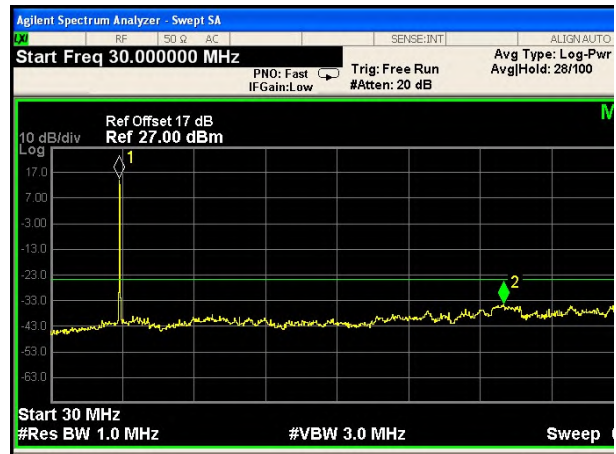
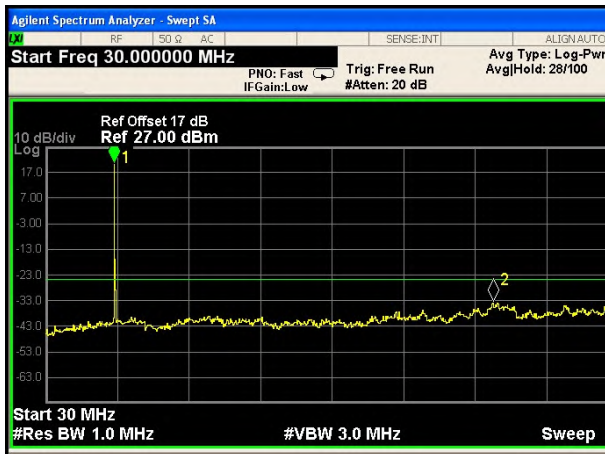

Middle channel

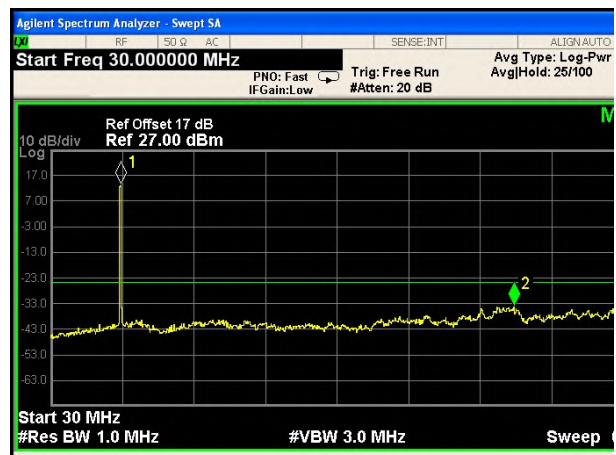
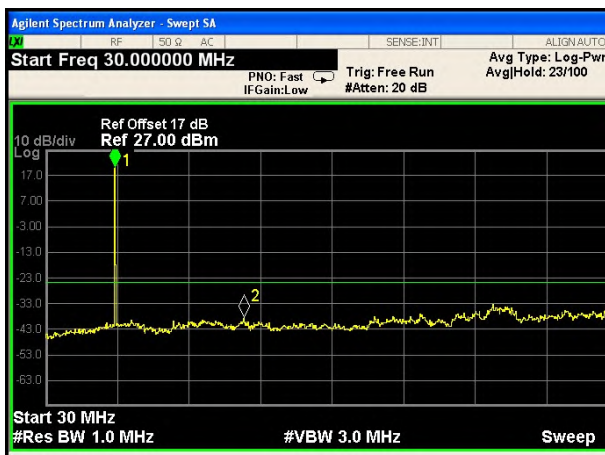

Highest channel

Band Edge

Test Mode: LTE Band 2 / 5MHz / 1RB / QPSK

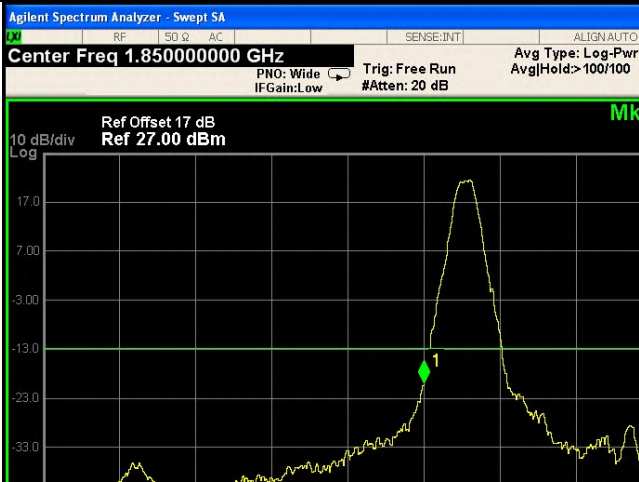

Lowest channel

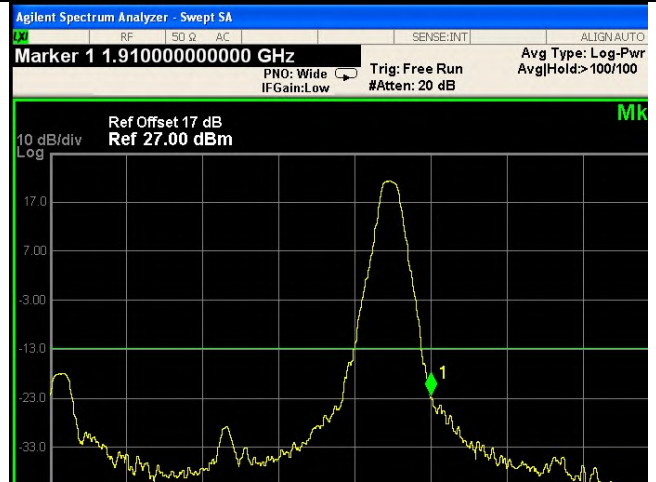

Highest channel

Test Mode: LTE Band 2 / 5MHz / 25RB / QPSK

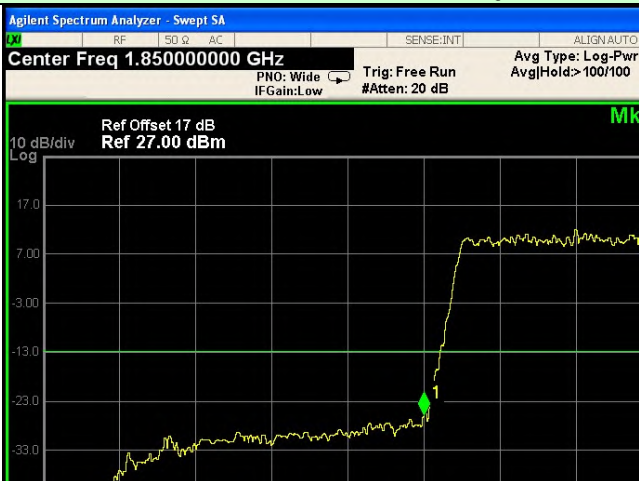

Lowest channel

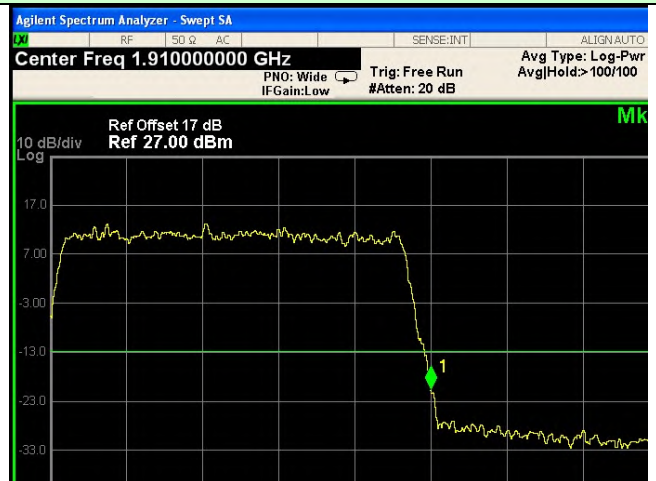

Highest channel

Test Mode: LTE Band 2 / 10MHz / 1RB / QPSK

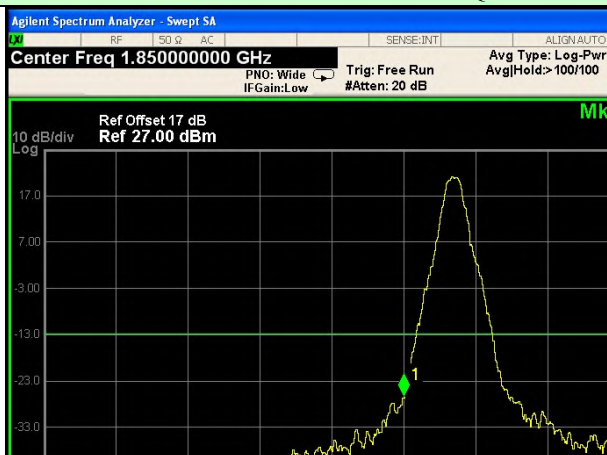

Lowest channel

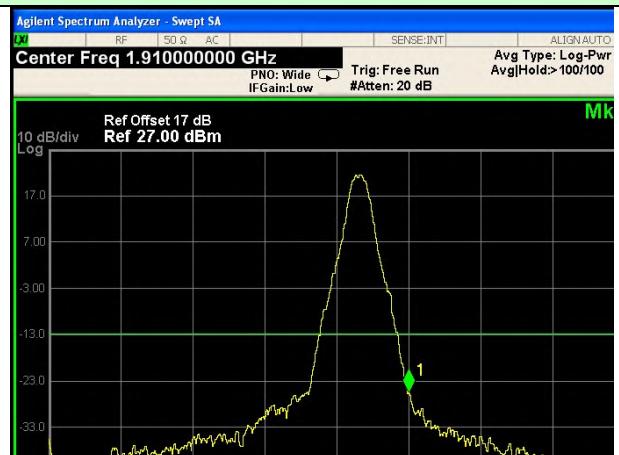

Highest channel

Test Mode: LTE Band 2 / 10MHz / 50RB / QPSK



Lowest channel

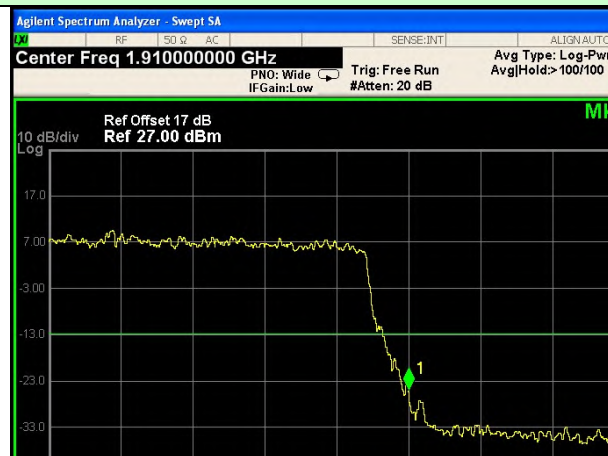

Highest channel

Test Mode: LTE Band 2 / 15MHz / 1RB / QPSK

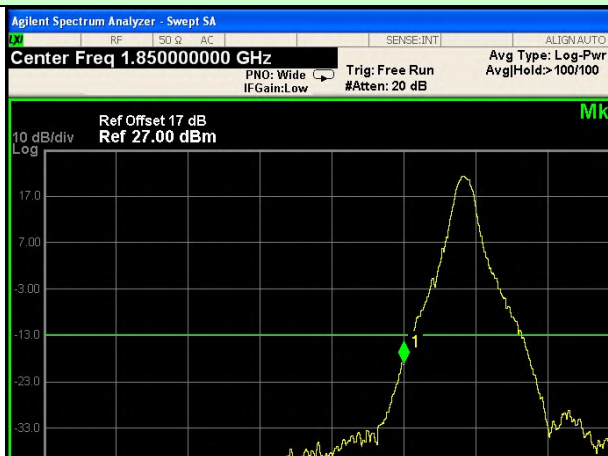

Lowest channel

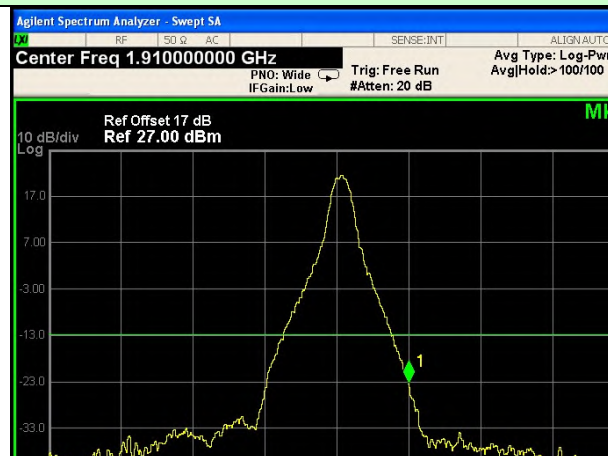

Highest channel

Test Mode: LTE Band 2 / 15MHz / 75RB / QPSK



Lowest channel



Highest channel

Test Mode: LTE Band 2 / 20MHz / 1RB / QPSK

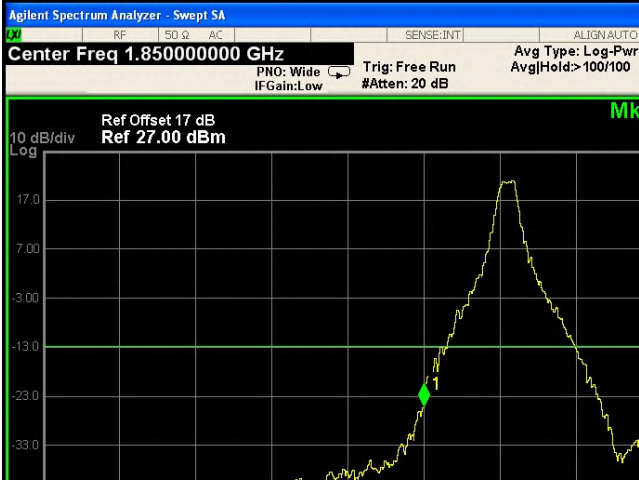

Lowest channel

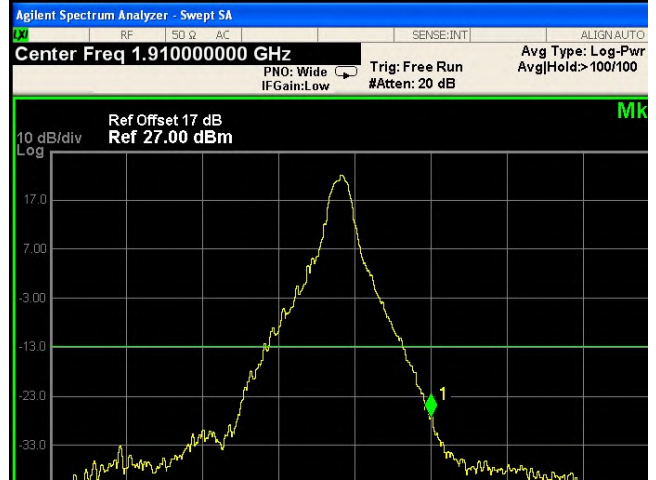

Highest channel

Test Mode: LTE Band 2 / 20MHz / 100RB / QPSK



Lowest channel



Highest channel

Test Mode: LTE Band 2 / 5MHz / 1RB / 16-QAM

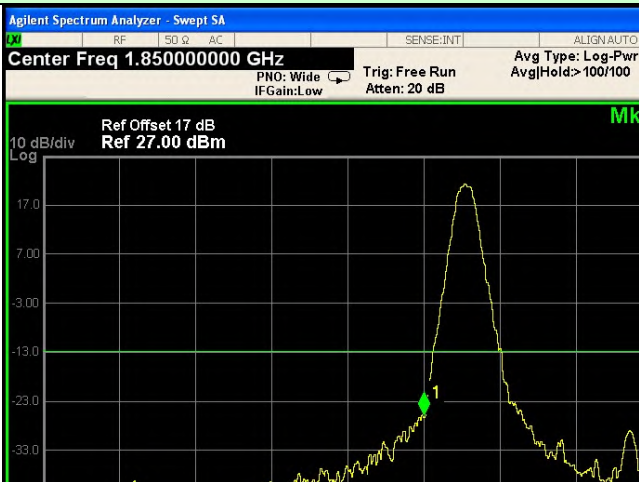

Lowest channel

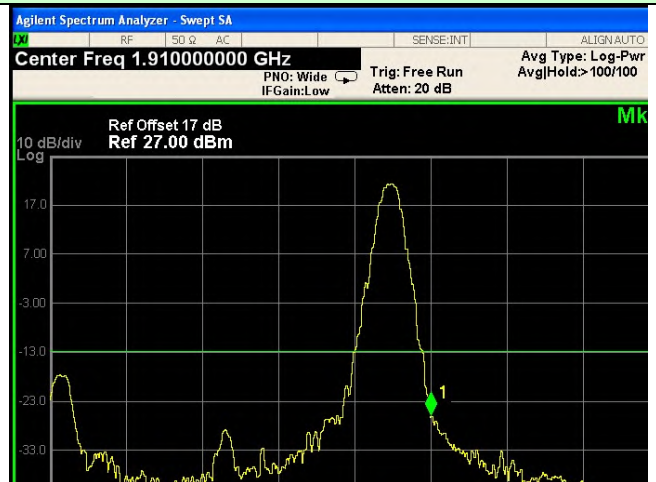

Highest channel

Test Mode: LTE Band 2 / 5MHz / 25RB / 16-QAM



Lowest channel



Highest channel

Test Mode: LTE Band 2 / 10MHz / 1RB / 16-QAM

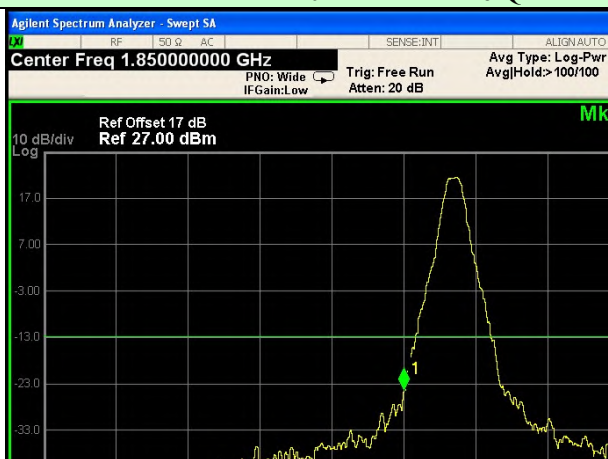

Lowest channel

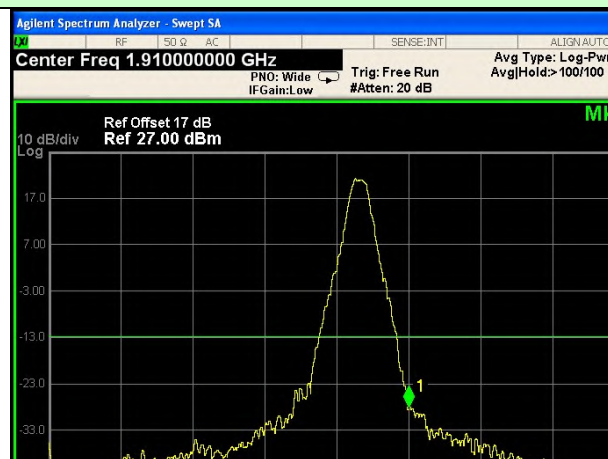

Highest channel

Test Mode: LTE Band 2 / 10MHz / 50RB / 16-QAM



Lowest channel

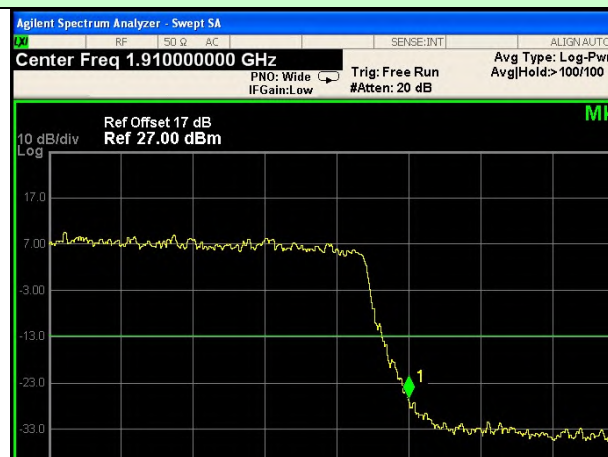

Highest channel

Test Mode: LTE Band 2 / 15MHz / 1RB / 16-QAM

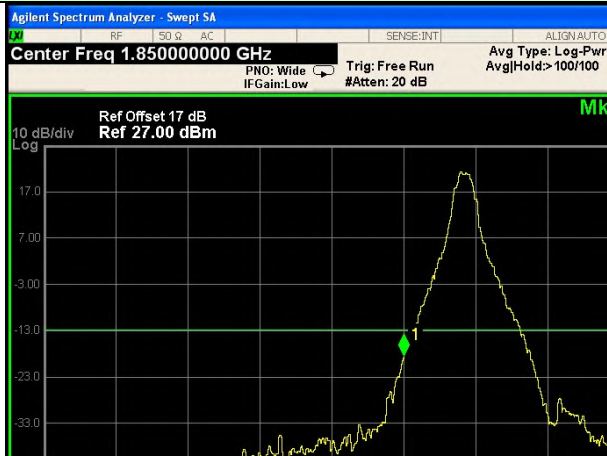

Lowest channel

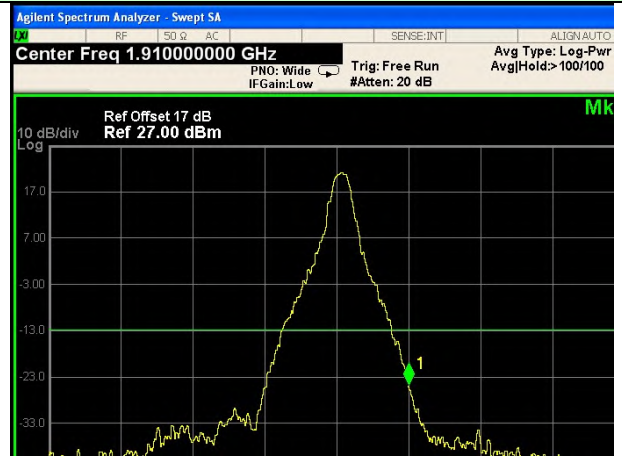

Highest channel

Test Mode: LTE Band 2 / 15MHz / 75RB / 16-QAM



Lowest channel

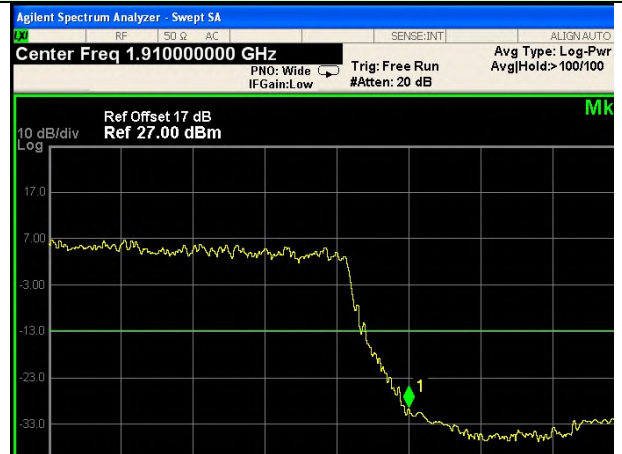

Highest channel

Test Mode: LTE Band 2 / 20MHz / 1RB / 16-QAM

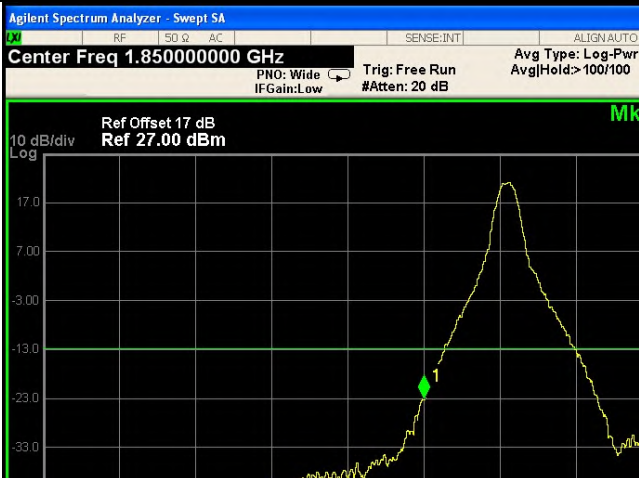

Lowest channel

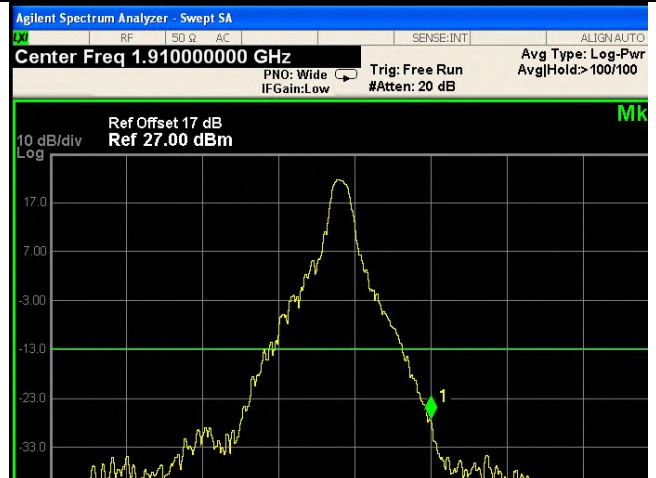

Highest channel

Test Mode: LTE Band 2 / 20MHz / 100RB / 16-QAM

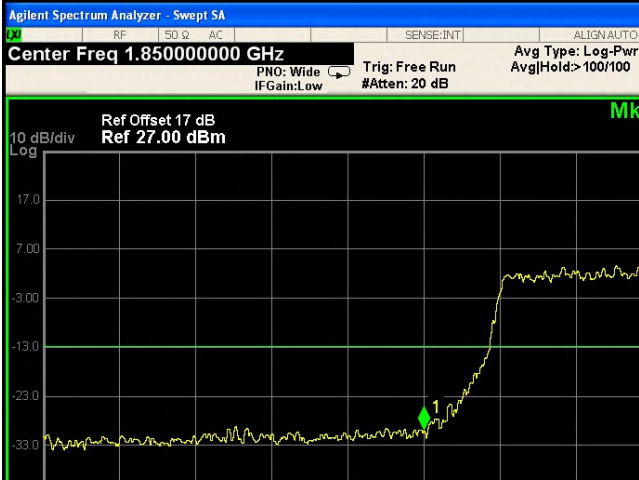

Lowest channel



Highest channel

Test Mode: LTE Band 4 / 5MHz / 1RB / QPSK

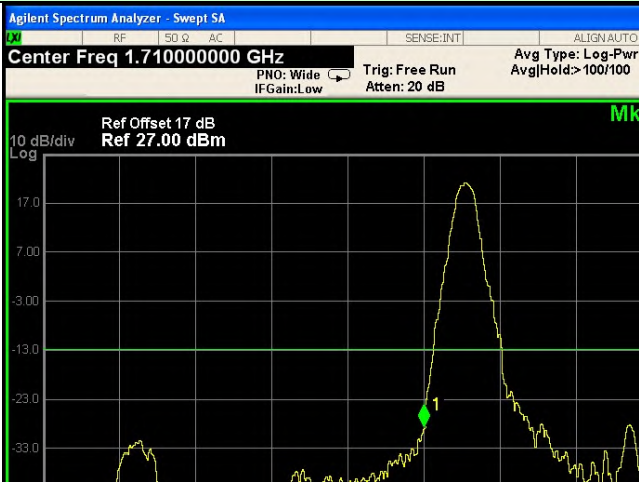

Lowest channel

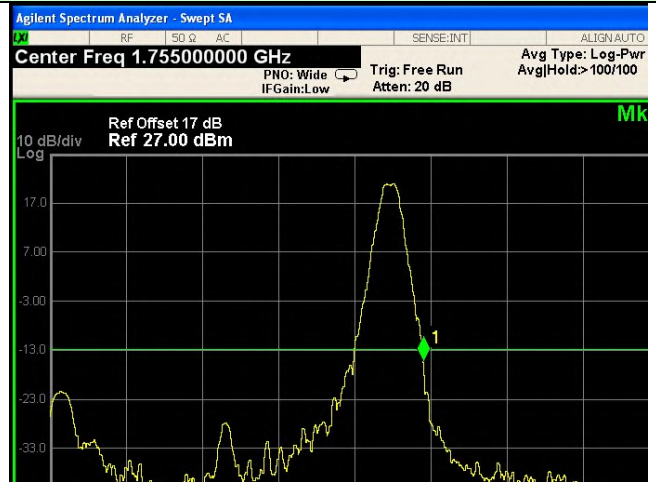

Highest channel

Test Mode: LTE Band 4 / 5MHz / 25RB / QPSK

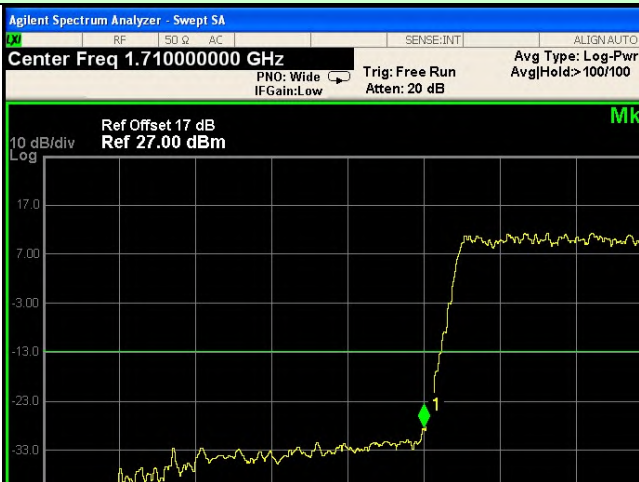

Lowest channel



Highest channel

Test Mode: LTE Band 4 / 10MHz / 1RB / QPSK

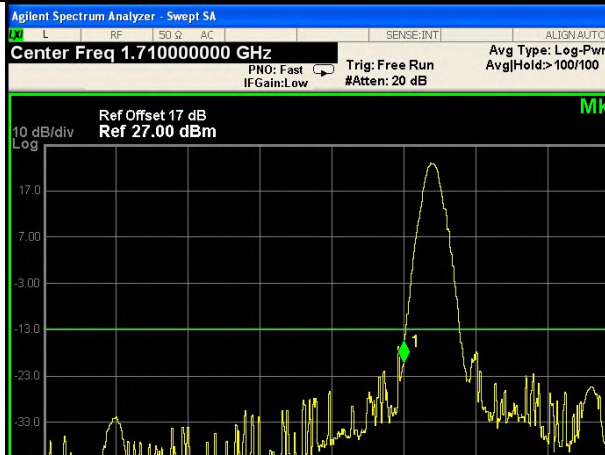

Lowest channel

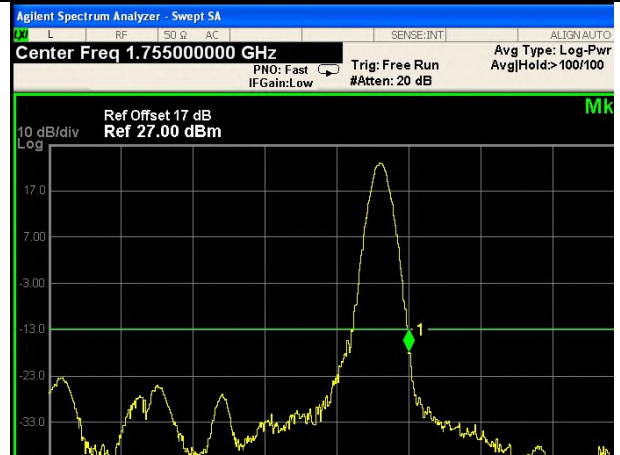

Highest channel

Test Mode: LTE Band 4 / 10MHz / 50RB / QPSK

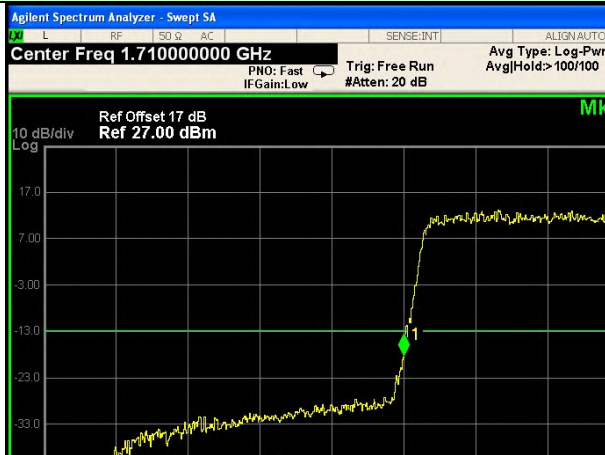

Lowest channel

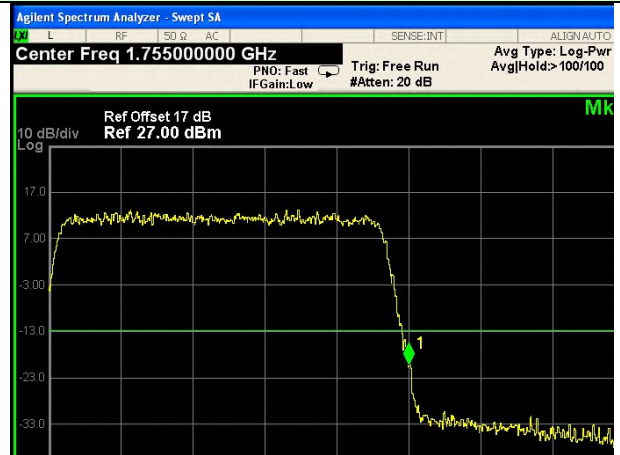

Highest channel

Test Mode: LTE Band 4 / 15MHz / 1RB / QPSK

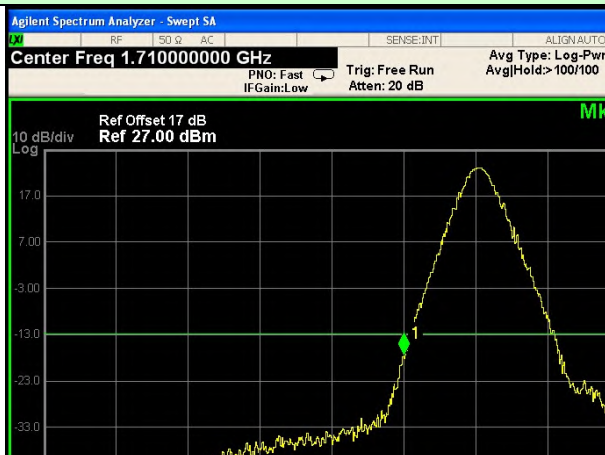

Lowest channel

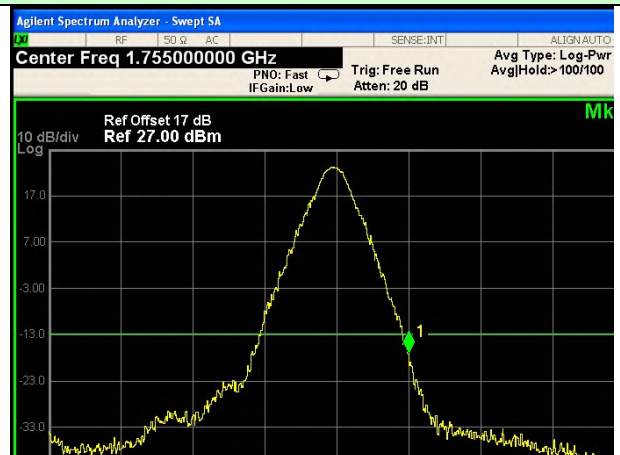

Highest channel

Test Mode: LTE Band 4 / 15MHz / 75RB / QPSK

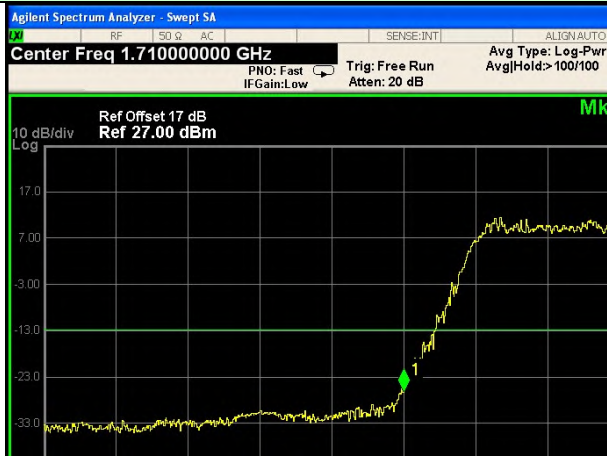

Lowest channel



Highest channel

Test Mode: LTE Band 4 / 20MHz / 1RB / QPSK



Lowest channel



Highest channel

Test Mode: LTE Band 4 / 20MHz / 100RB / QPSK

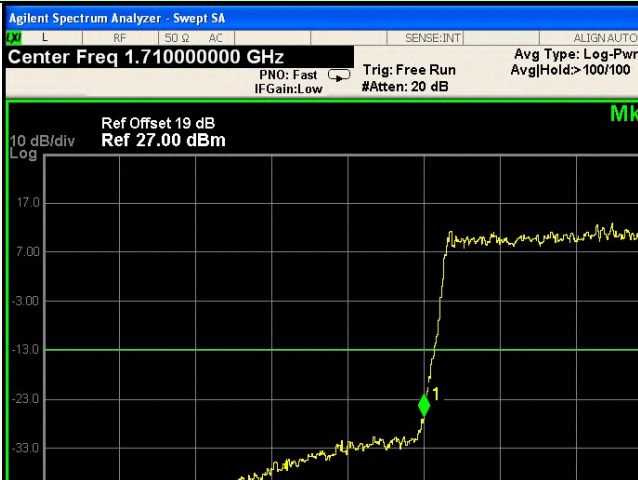

Lowest channel



Highest channel

Test Mode: LTE Band 4 / 5MHz / 1RB / 16-QAM

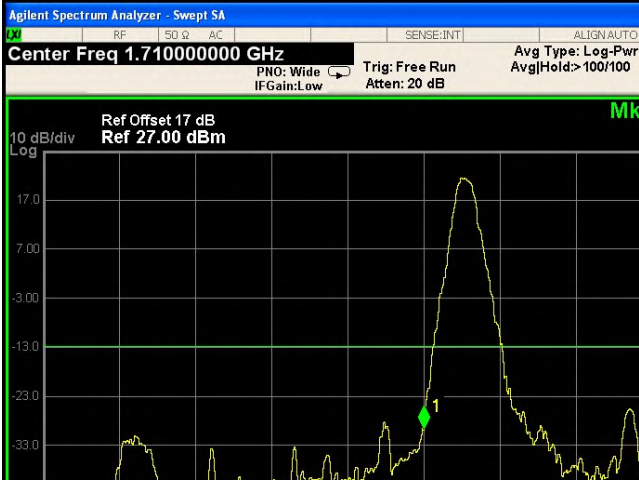

Lowest channel



Highest channel

Test Mode: LTE Band 4 / 5MHz / 25RB / 16-QAM

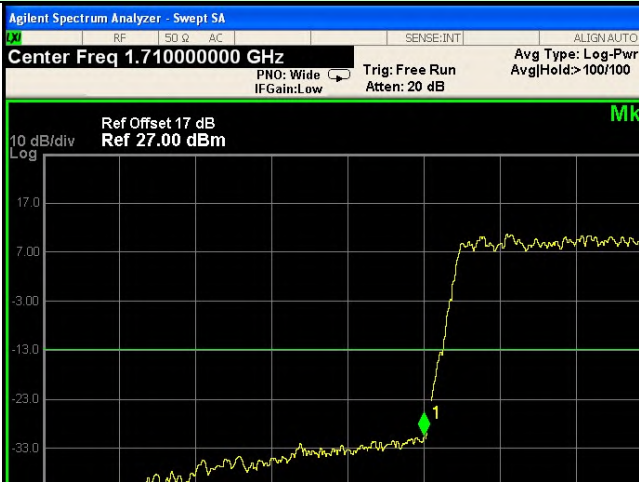

Lowest channel

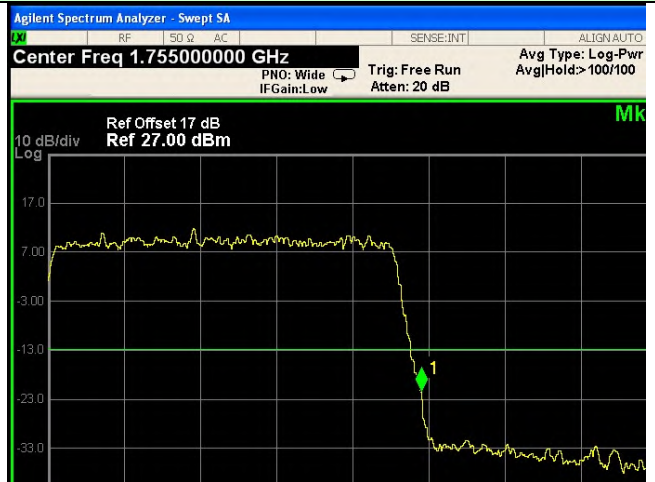

Highest channel

Test Mode: LTE Band 4 / 10MHz / 1RB / 16-QAM

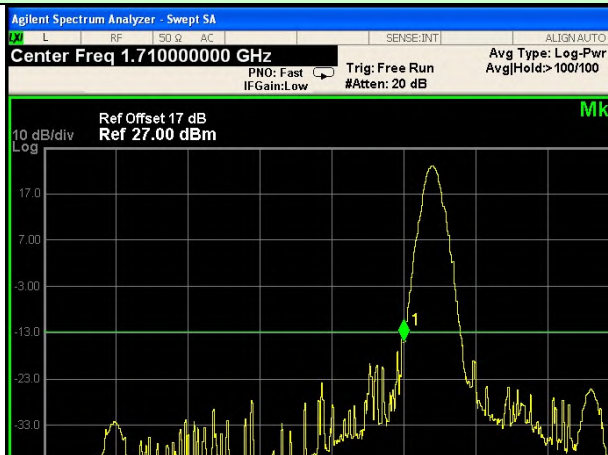

Lowest channel



Highest channel

Test Mode: LTE Band 4 / 10MHz / 50RB / 16-QAM



Lowest channel

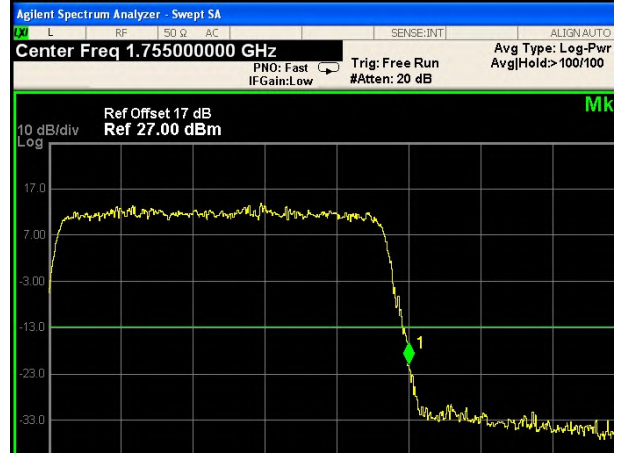

Highest channel

Test Mode: LTE Band 4 / 15MHz / 1RB / 16-QAM

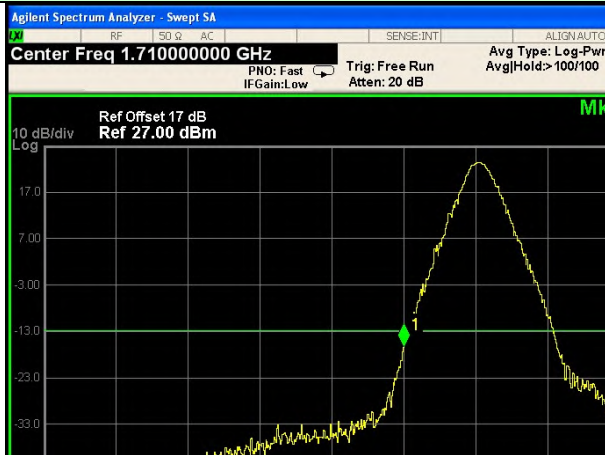

Lowest channel

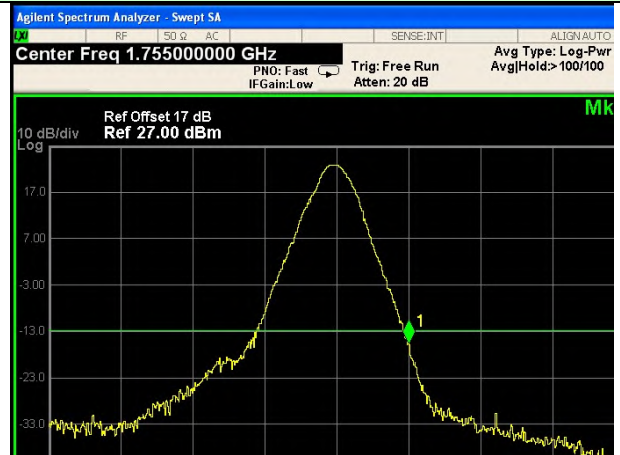

Highest channel

Test Mode: LTE Band 4 / 15MHz / 75RB / 16-QAM

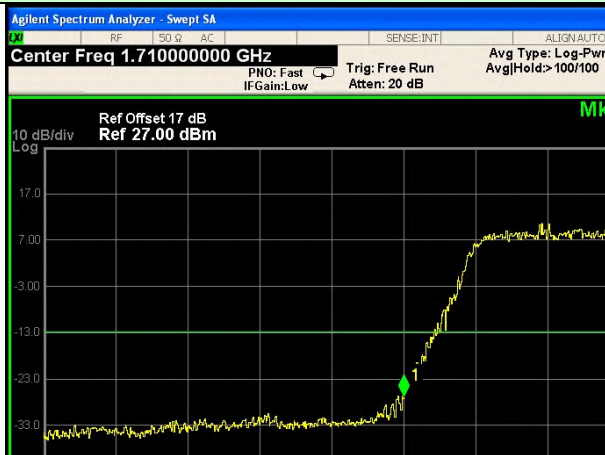

Lowest channel



Highest channel

Test Mode: LTE Band 4 / 20MHz / 1RB / 16-QAM

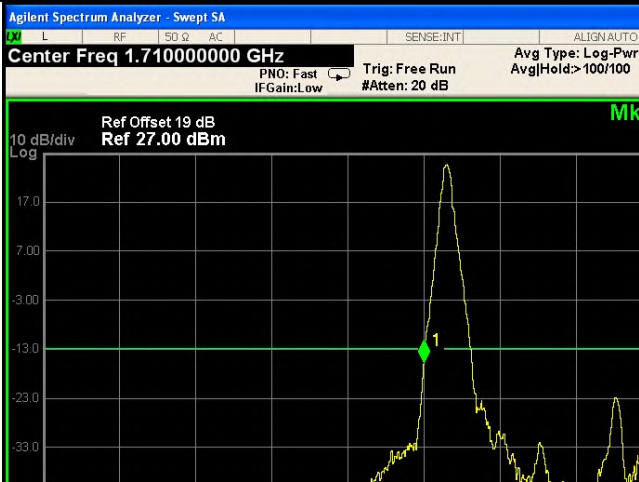

Lowest channel



Highest channel

Test Mode: LTE Band 4 / 20MHz / 100RB / 16-QAM

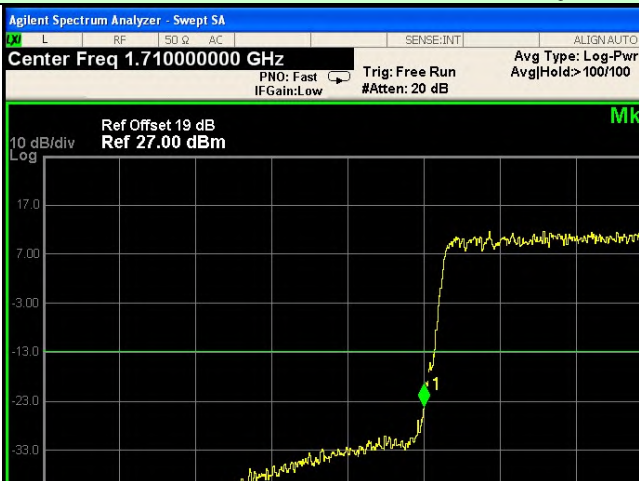

Lowest channel

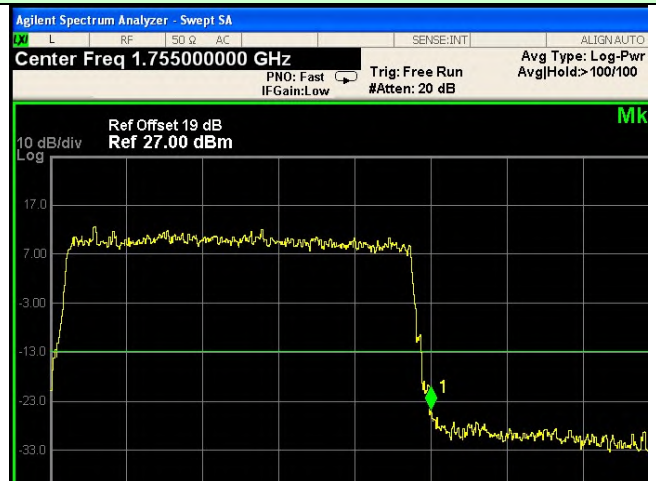

Highest channel

Test Mode: LTE Band 5 / 5MHz / 1RB / QPSK

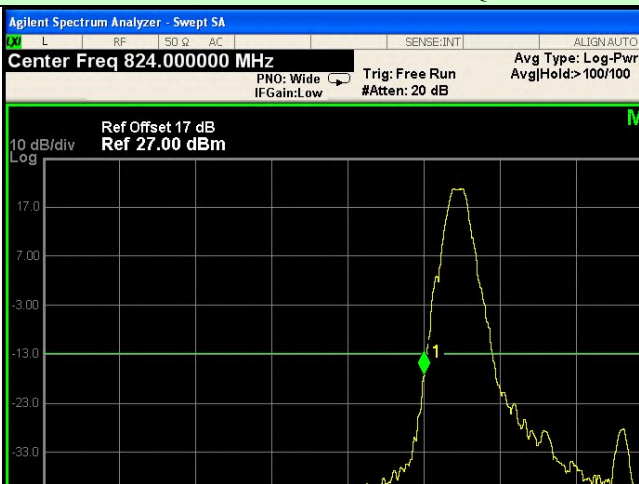

Lowest channel

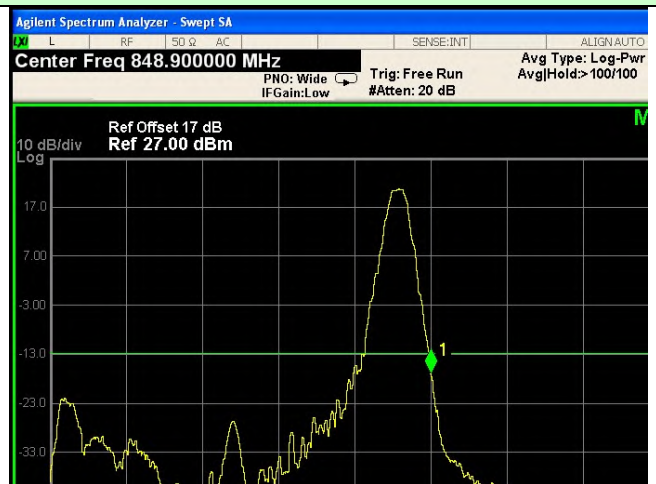

Highest channel

Test Mode: LTE Band 5 / 5MHz / 25RB / QPSK



Lowest channel



Highest channel

Test Mode: LTE Band 5 / 10MHz / 1RB / QPSK



Lowest channel

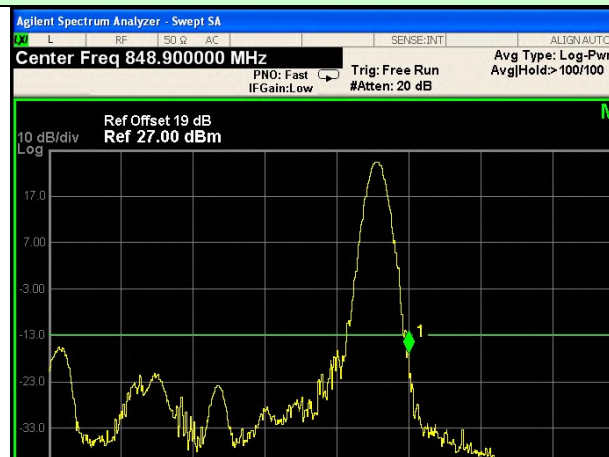

Highest channel

Test Mode: LTE Band 5 / 10MHz / 50RB / QPSK



Lowest channel



Highest channel

Test Mode: LTE Band 5 / 5MHz / 1RB / 16-QAM

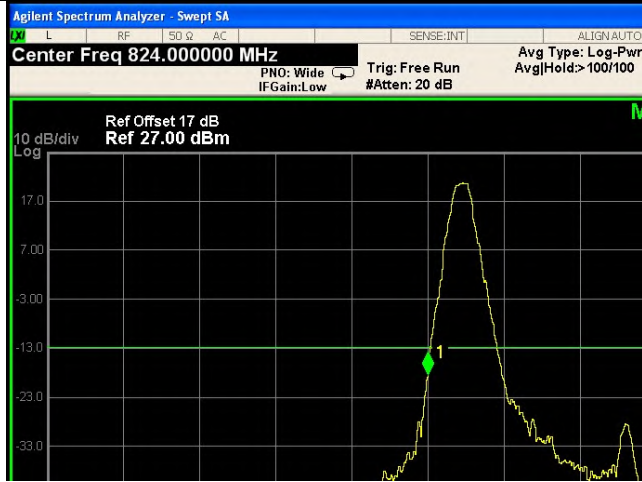

Lowest channel

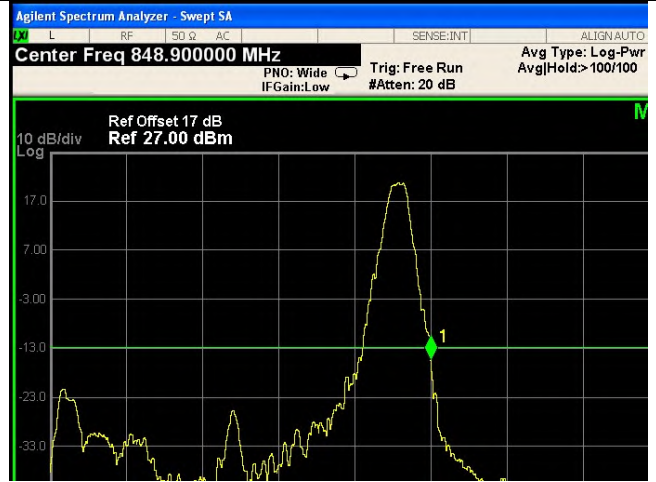

Highest channel

Test Mode: LTE Band 5 / 5MHz / 25RB / 16-QAM

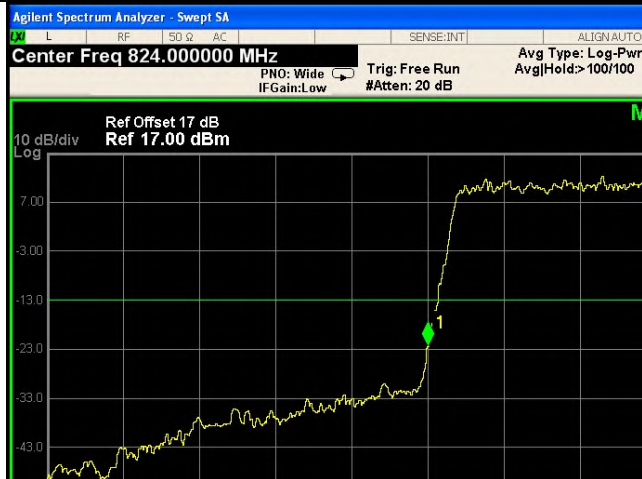

Lowest channel

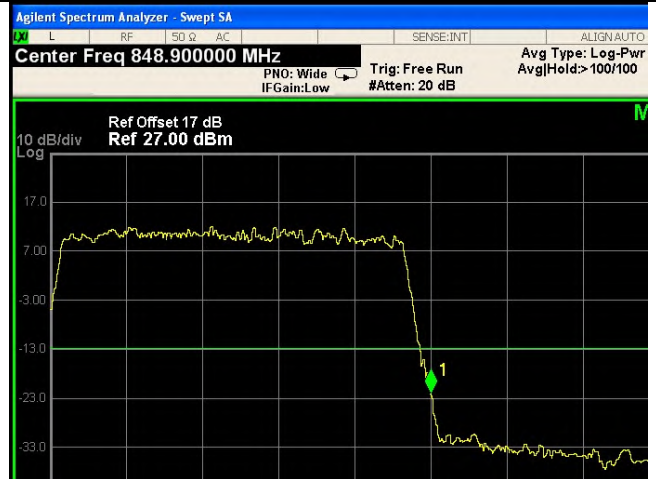

Highest channel

Test Mode: LTE Band 5 / 10MHz / 1RB / 16-QAM

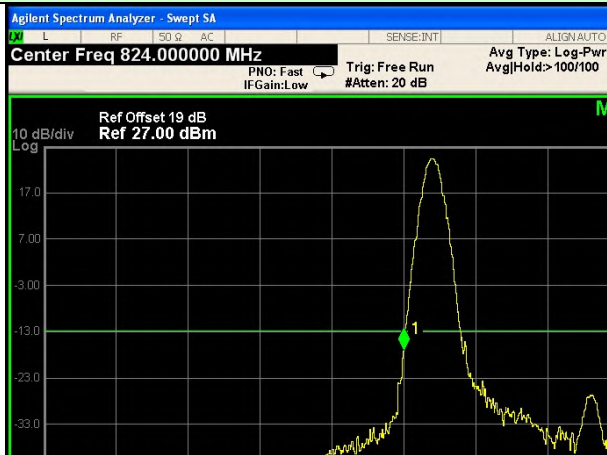

Lowest channel

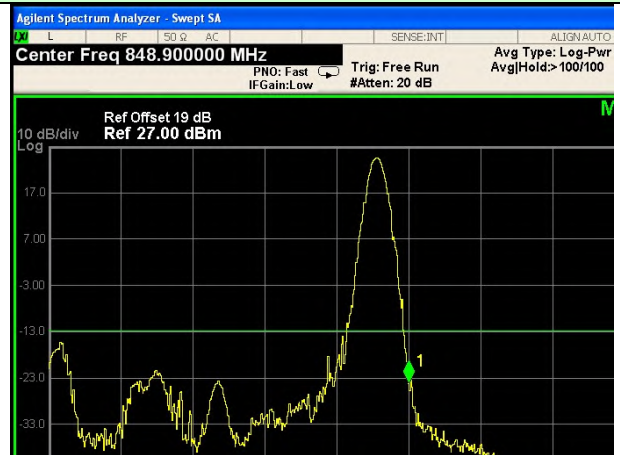

Highest channel

Test Mode: LTE Band 5 / 10MHz / 50RB / 16-QAM

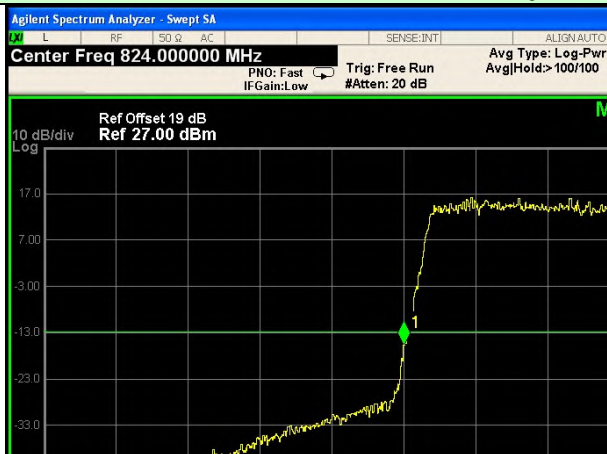

Lowest channel

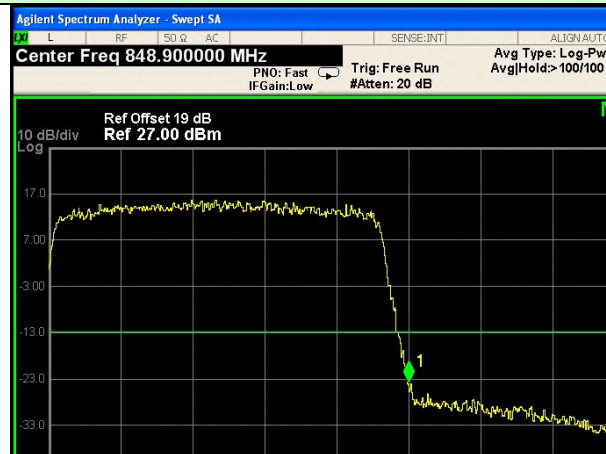

Highest channel

Test Mode: LTE Band 7 / 5MHz / 1RB / QPSK

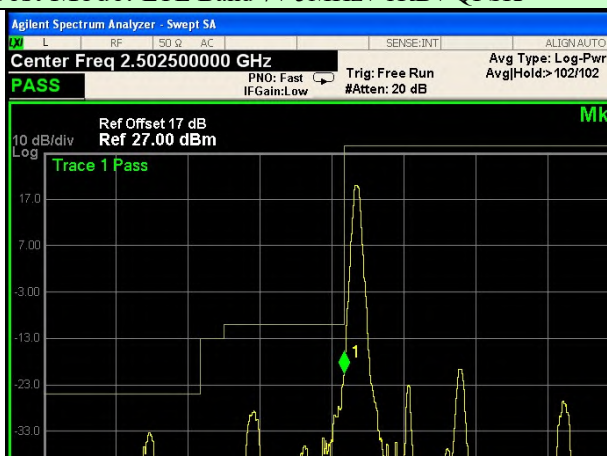

Lowest channel

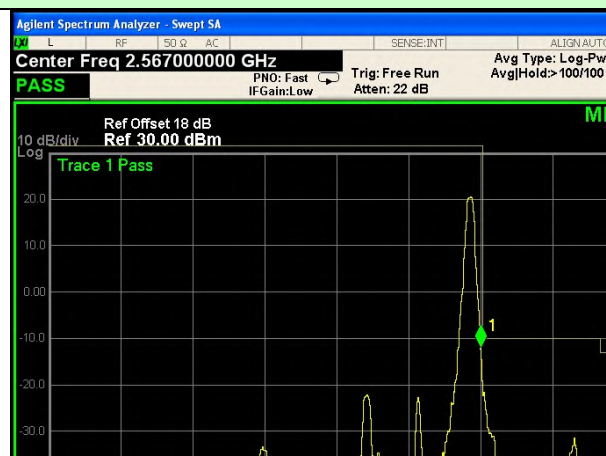

Highest channel

Test Mode: LTE Band 7 / 5MHz / 25RB / QPSK



Lowest channel



Highest channel

Test Mode: LTE Band 7 / 10MHz / 1RB / QPSK

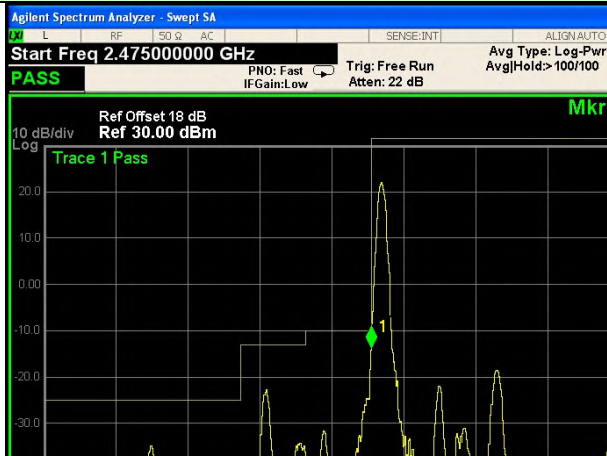

Lowest channel

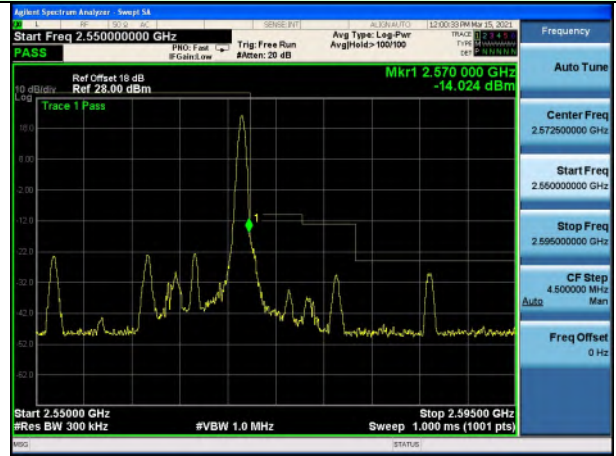

Highest channel

Test Mode: LTE Band 7 / 10MHz / 50RB / QPSK

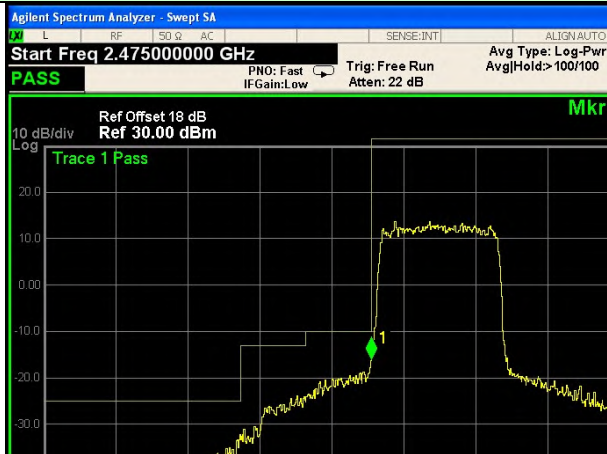

Lowest channel



Highest channel

Test Mode: LTE Band 7 / 15MHz / 1RB / QPSK

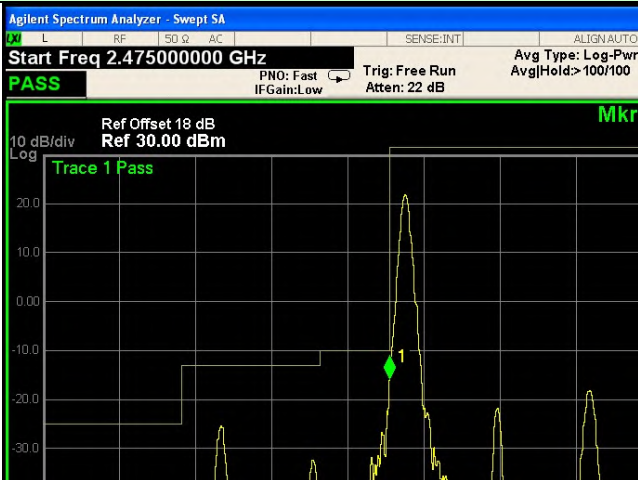

Lowest channel

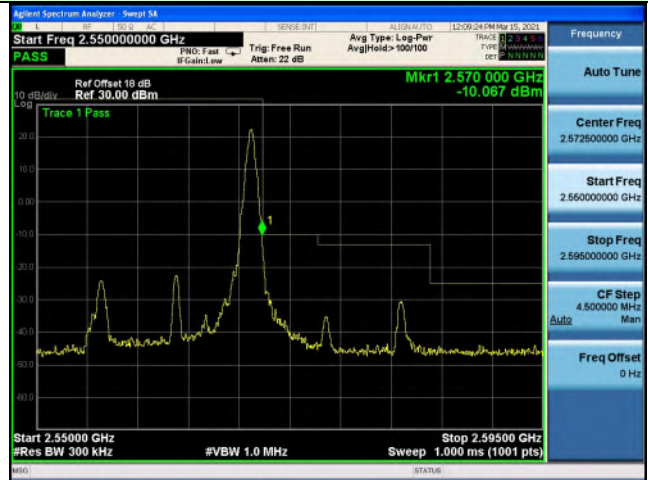

Highest channel

Test Mode: LTE Band 7 / 15MHz / 75RB / QPSK

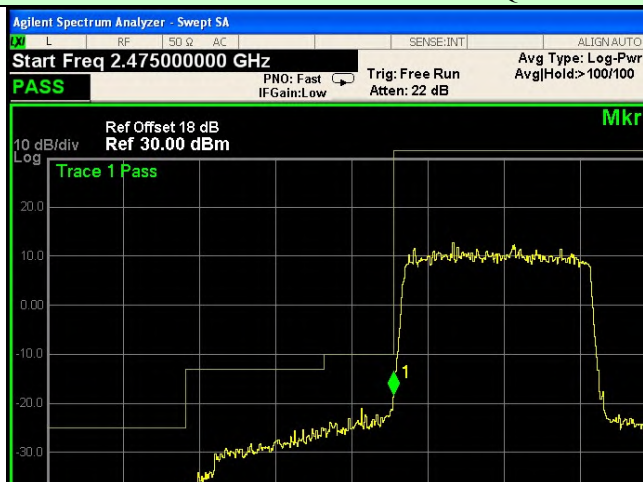

Lowest channel

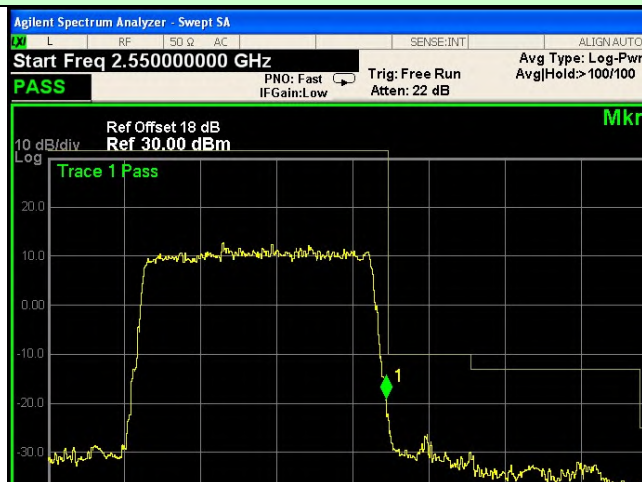

Highest channel

Test Mode: LTE Band 7 / 20MHz / 1RB / QPSK



Lowest channel

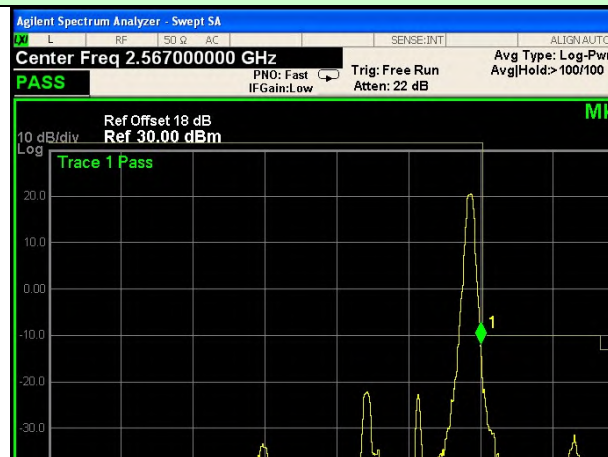

Highest channel

Test Mode: LTE Band 7 / 20MHz / 100RB / QPSK

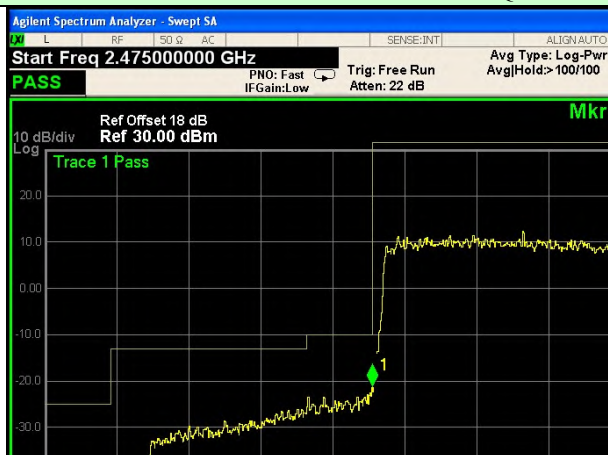

Lowest channel

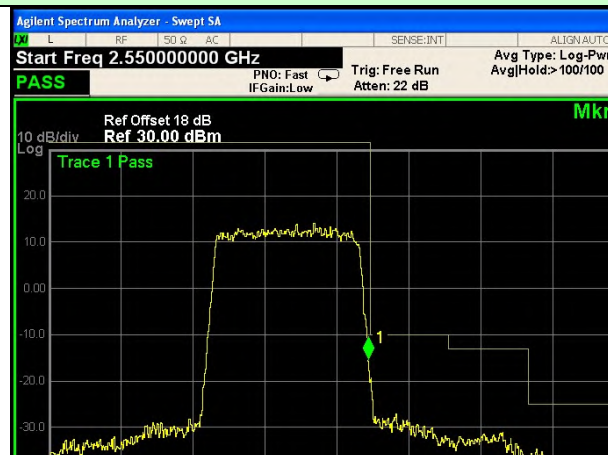

Highest channel

Test Mode: LTE Band 7 / 5MHz / 1RB / 16-QAM

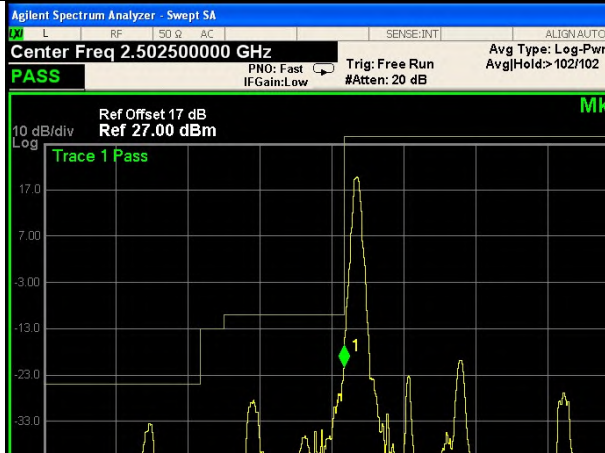

Lowest channel

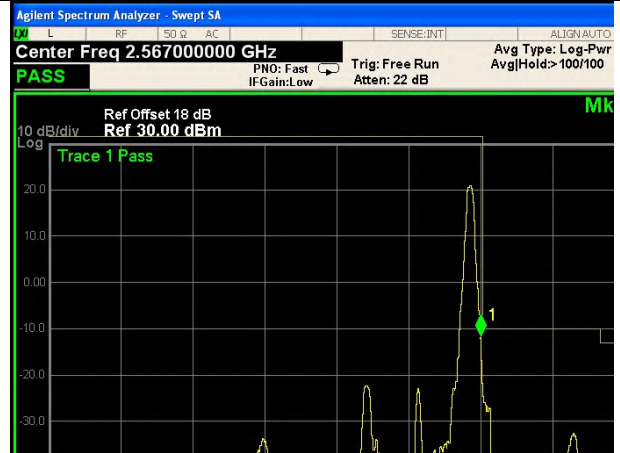

Highest channel

Test Mode: LTE Band 7 / 5MHz / 25RB / 16-QAM

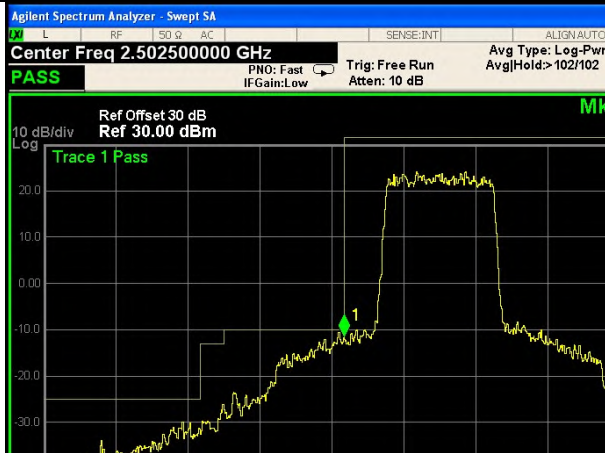

Lowest channel



Highest channel

Test Mode: LTE Band 7 / 10MHz / 1RB / 16-QAM

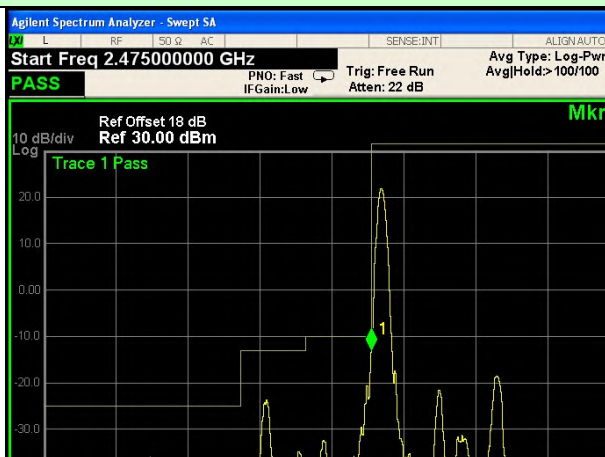

Lowest channel

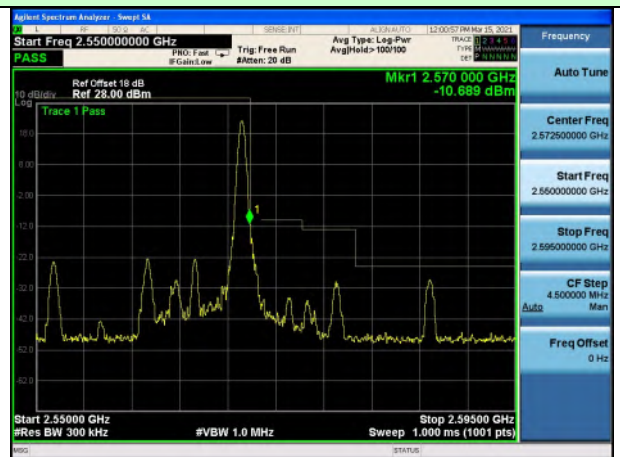

Highest channel

Test Mode: LTE Band 7 / 10MHz / 50RB / 16-QAM

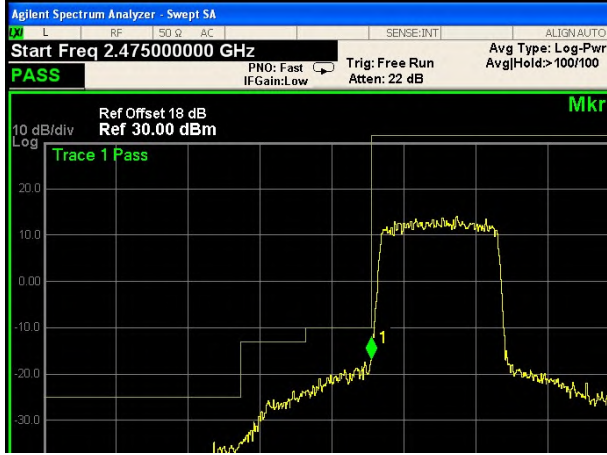

Lowest channel

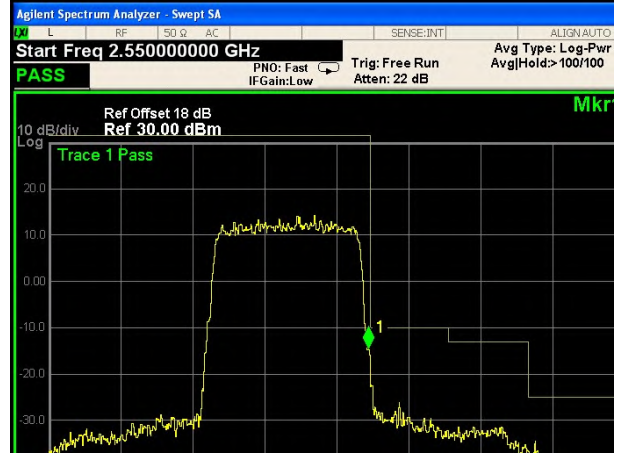

Highest channel

Test Mode: LTE Band 7 / 15MHz / 1RB / 16-QAM

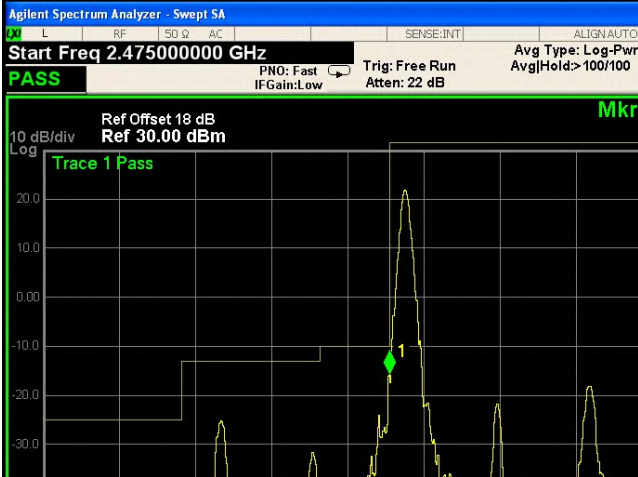

Lowest channel



Highest channel

Test Mode: LTE Band 7 / 15MHz / 75RB / 16-QAM

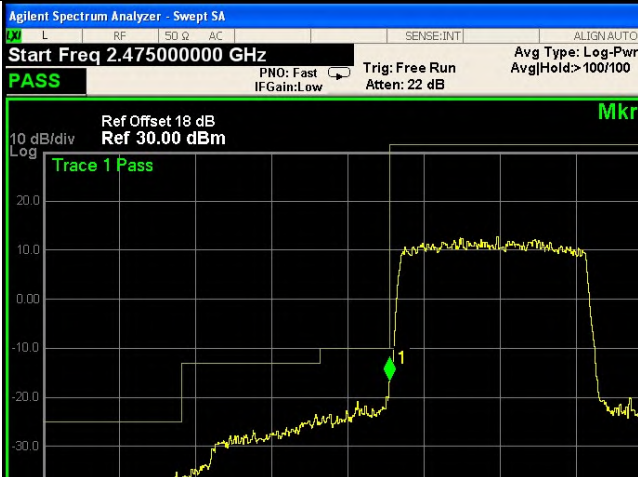

Lowest channel



Highest channel

Test Mode: LTE Band 7 / 20MHz / 1RB / 16-QAM

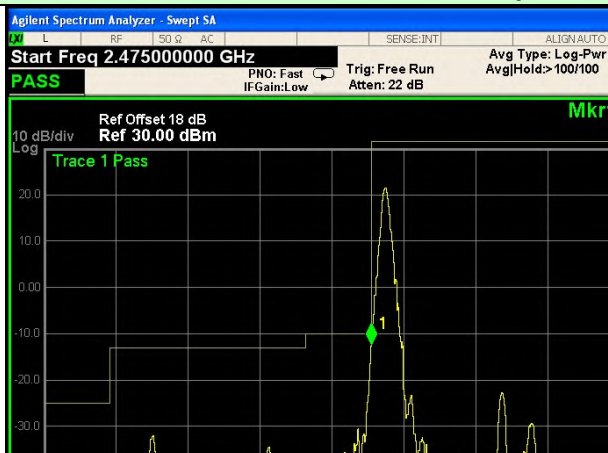

Lowest channel

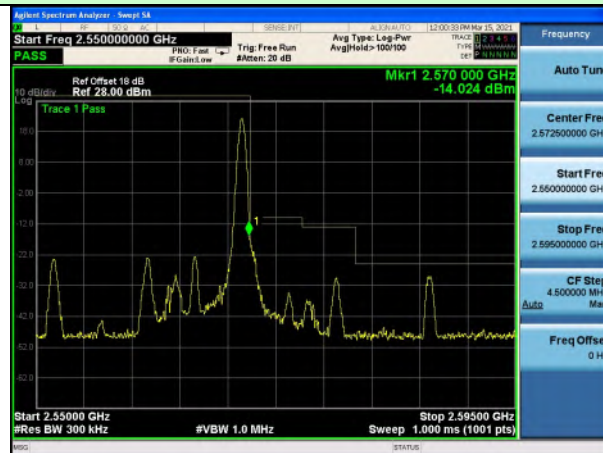

Highest channel

Test Mode: LTE Band 7 / 20MHz / 100RB / 16-QAM

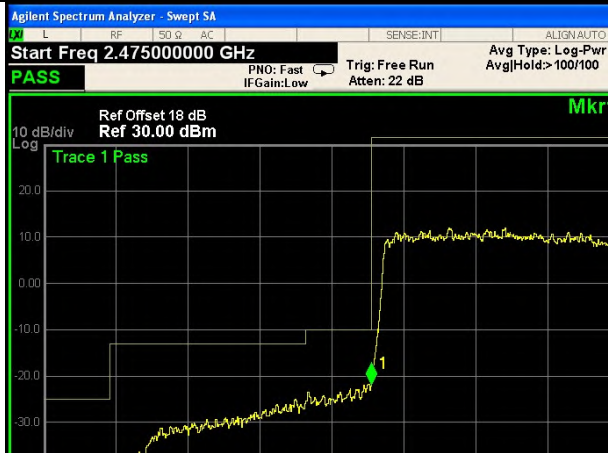

Lowest channel



Highest channel

Note: All bandwidth and modulation are tested, only the worst result is reported.

4.8 ERP, EIRP Measurement

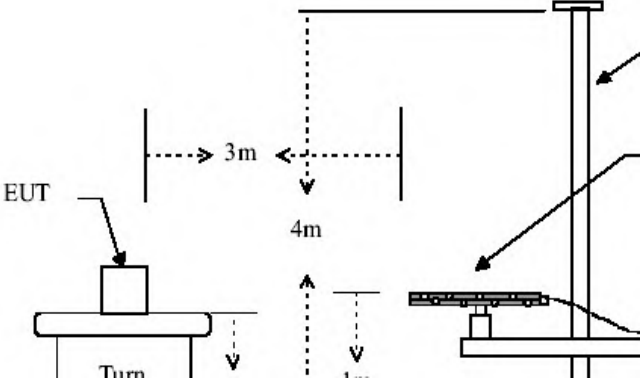
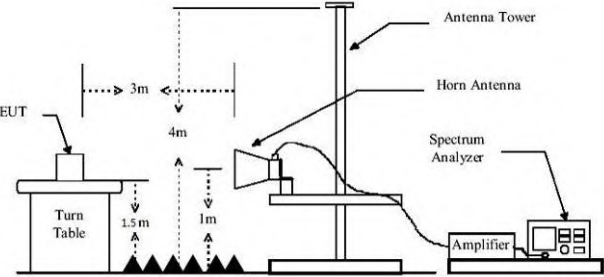
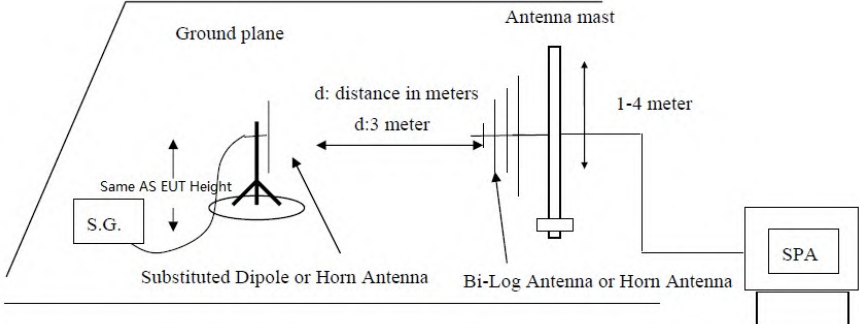
<p>Test Requirement:</p>	<p>FCC part22.913(a), FCC part24.232(b), FCC part 27.53, and RSS-132 (5.4), RSS-133 (6.4), RSS-139(6.5) and RSS-199(4.4)</p>
<p>Test Method:</p>	<p>KDB 971168 D01 v03r1 clause 5.8, FCC part2.1051, ANSI/TIA-603-E, ANSI C63.26 clause 5.7</p>
<p>Limit:</p>	<p>LTE Band 2: 2W (EIRP) LTE Band 4: 1W (EIRP) LTE Band 5(Upper Band): [7W (ERP) for FCC, 11.5W(EIRP) for ISED] LTE Band 7: 2W (EIRP)</p>
<p>Test setup:</p>	<p>Below 1GHz</p>  <p>Above 1GHz</p>  <p>Substituted method:</p> 

Test Procedure:	<ol style="list-style-type: none"> 1. The EUT was placed on a non-conductive turntable using a non-conductive support. The radiated emission at the fundamental frequency was measured at 3 m with a test antenna and EMI spectrum analyzer. 2. During the measurement, the EUT was in communication with the station. The highest emission was recorded with the rotation of the turntable and the lowering of the test antenna from 4m to 1m. The reading was recorded and the field strength (E in dBuV/m) was calculated. 3. ERP were measured using a substitution method. The EUT was replaced by a dipole antenna connected, the S.G. output was recorded and ERP was calculated as follows: $\text{ERP} = \text{S.G. output (dBm)} + \text{Antenna Gain (dBd)} - \text{Cable Loss (dB)}$ 4. EIRP were measured using a substitution method. The EUT was replaced by a horn antenna connected, the S.G. output was recorded and EIRP was calculated as follows: $\text{EIRP} = \text{S.G. output (dBm)} + \text{Antenna Gain (dBi)} - \text{Cable Loss (dB)}$
Test Instruments:	Refer to section 3 for details
Test mode:	Refer to section 4.1 for details
Test results:	Pass

Measurement Data

	Frequency (MHz)	PMea (dBm)	Pcl(dB)+PAg(dB)	Ga Antenna Gain(dBi)	EIRP (dBm)	Limit (dBm)	Polarity	Margin (dB)
LTE BAND 2 QPSK-5MHz	1852.50	-14.11	-29.30	9.80	24.99	33.00	H	-8.01
	1880.00	-14.41	-29.40	9.80	24.79	33.00	H	-8.21
	1907.50	-14.16	-29.30	9.80	24.94	33.00	H	-8.06
LTE BAND 2 QPSK-10MHz	Frequency (MHz)	PMea (dBm)	Pcl(dB)+PAg(dB)	Ga Antenna Gain(dBi)	EIRP (dBm)	Limit (dBm)	Polarity	Margin (dB)
	1855.00	-14.41	-29.30	9.80	24.69	33.00	H	-8.31
	1880.00	-14.67	-29.40	9.80	24.53	33.00	H	-8.47
	1905.00	-14.20	-29.30	9.80	24.90	33.00	H	-8.10
LTE BAND 2 QPSK-15MHz	Frequency (MHz)	PMea (dBm)	Pcl(dB)+PAg(dB)	Ga Antenna Gain(dBi)	EIRP (dBm)	Limit (dBm)	Polarity	Margin (dB)
	1857.50	1857.5	-29.30	9.80	24.74	33.00	H	-8.26
	1880.00	1880	-29.40	9.80	24.91	33.00	H	-8.09
	1902.50	1902.5	-29.30	9.80	24.81	33.00	H	-8.19
LTE BAND 2 QPSK-20MHz	Frequency (MHz)	PMea (dBm)	Pcl(dB)+PAg(dB)	Ga Antenna Gain(dBi)	EIRP (dBm)	Limit (dBm)	Polarity	Margin (dB)
	1860.00	-14.40	-29.30	9.80	24.70	33.00	H	-8.30
	1880.00	-15.13	-29.40	9.80	24.07	33.00	H	-8.93
	1900.00	-14.94	-29.30	9.80	24.16	33.00	H	-8.84
LTE BAND 2 16QAM-5MHz	Frequency (MHz)	PMea (dBm)	Pcl(dB)+PAg(dB)	Ga Antenna Gain(dBi)	EIRP (dBm)	Limit (dBm)	Polarity	Margin (dB)
	1852.50	-14.12	-29.30	9.80	24.98	33.00	H	-8.02
	1880.00	-14.52	-29.40	9.80	24.68	33.00	H	-8.32
	1907.50	-14.29	-29.30	9.80	24.81	33.00	H	-8.19
LTE BAND 2 16QAM-10MHz	Frequency (MHz)	PMea (dBm)	Pcl(dB)+PAg(dB)	Ga Antenna Gain(dBi)	EIRP (dBm)	Limit (dBm)	Polarity	Margin (dB)
	1855.00	-14.43	-29.30	9.80	24.67	33.00	H	-8.33
	1880.00	-15.17	-29.40	9.80	24.03	33.00	H	-8.97
	1905.00	-14.57	-29.30	9.80	24.53	33.00	H	-8.47
LTE BAND 2 16QAM-15MHz	Frequency (MHz)	PMea (dBm)	Pcl(dB)+PAg(dB)	Ga Antenna Gain(dBi)	EIRP (dBm)	Limit (dBm)	Polarity	Margin (dB)
	1857.50	-14.92	-29.30	9.80	24.18	33.00	H	-8.82
	1880.00	-15.00	-29.40	9.80	24.20	33.00	H	-8.80
	1902.50	-14.11	-29.30	9.80	24.99	33.00	H	-8.01
LTE BAND 2 16QAM-20MHz	Frequency (MHz)	PMea (dBm)	Pcl(dB)+PAg(dB)	Ga Antenna Gain(dBi)	EIRP (dBm)	Limit (dBm)	Polarity	Margin (dB)
	1860.00	-14.53	-29.30	9.80	24.57	33.00	H	-8.43
	1880.00	-14.65	-29.40	9.80	24.55	33.00	H	-8.45
	1900.00	-14.95	-29.30	9.80	24.15	33.00	H	-8.85

Remark:EIRP=PMea-Pcl-PAg+Ga Antenna Gain.

	Frequency (MHz)	PMea (dBm)	Pcl(dB)+PA g(dB)	Ga Antenna Gain (dBi)	EIRP (dBm)	Limit (dBm)	Polarity	Margin (dB)
LTE BAND 4 QPSK-5MHz	1712.50	-13.27	-29.60	8.10	24.43	30.00	H	-5.57
	1732.50	-12.80	-29.60	8.10	24.90	30.00	H	-5.10
	1752.50	-13.40	-29.50	8.10	24.20	30.00	H	-5.80
LTE BAND 4 QPSK-10MHz	Frequency (MHz)	PMea (dBm)	Pcl(dB)+P Ag(dB)	Ga Antenna Gain(dBi)	EIRP (dBm)	Limit (dBm)	Polarity	Margin (dB)
	1715.00	-13.51	-29.60	8.10	24.19	30.00	H	-5.81
	1732.50	-13.00	-29.60	8.10	24.70	30.00	H	-5.30
	1750.00	-12.68	-29.50	8.10	24.92	30.00	H	-5.08
LTE BAND 4 QPSK-15MHz	Frequency (MHz)	PMea (dBm)	Pcl(dB)+PA g(dB)	Ga Antenna Gain (dBi)	EIRP (dBm)	Limit (dBm)	Polarity	Margin (dB)
	1717.50	-12.86	-29.60	8.10	24.84	30.00	H	-5.16
	1732.50	-12.90	-29.60	8.10	24.80	30.00	H	-5.20
	1747.50	-12.67	-29.50	8.10	24.93	30.00	H	-5.07
LTE BAND 4 QPSK-20MHz	Frequency (MHz)	PMea (dBm)	Pcl(dB)+P Ag(dB)	Ga Antenna Gain(dBi)	EIRP (dBm)	Limit (dBm)	Polarity	Margin (dB)
	1720.00	-12.98	-29.60	8.10	24.72	30.00	H	-5.28
	1732.50	-13.69	-29.60	8.10	24.01	30.00	H	-5.99
	1745.00	-13.23	-29.50	8.10	24.37	30.00	H	-5.63
LTE BAND 4 16QAM-5MHz	Frequency (MHz)	PMea (dBm)	Pcl(dB)+P Ag(dB)	Ga Antenna Gain(dBi)	EIRP (dBm)	Limit (dBm)	Polarity	Margin (dB)
	1712.50	-12.77	-29.60	8.10	24.93	30.00	H	-5.07
	1732.50	-13.18	-29.60	8.10	24.52	30.00	H	-5.48
	1752.50	-12.87	-29.50	8.10	24.73	30.00	H	-5.27
LTE BAND 4 16QAM-10MHz	Frequency (MHz)	PMea (dBm)	Pcl(dB)+P Ag(dB)	Ga Antenna Gain(dBi)	EIRP (dBm)	Limit (dBm)	Polarity	Margin (dB)
	1715.00	-12.71	-29.60	8.10	24.99	30.00	H	-5.01
	1732.50	-12.85	-29.60	8.10	24.85	30.00	H	-5.15
	1750.00	-12.76	-29.50	8.10	24.84	30.00	H	-5.16
LTE BAND 4 16QAM-15MHz	Frequency (MHz)	PMea (dBm)	Pcl(dB)+P Ag(dB)	Ga Antenna Gain(dBi)	EIRP (dBm)	Limit (dBm)	Polarity	Margin (dB)
	1717.50	-13.68	-29.60	8.10	24.02	30.00	H	-5.98
	1732.50	-13.68	-29.60	8.10	24.02	30.00	H	-5.98
	1747.50	-13.12	-29.50	8.10	24.48	30.00	H	-5.52
LTE BAND 4 16QAM-20MHz	Frequency (MHz)	PMea (dBm)	Pcl(dB)+P Ag(dB)	Ga Antenna Gain(dBi)	EIRP (dBm)	Limit (dBm)	Polarity	Margin (dB)
	1720.00	-13.07	-29.60	8.10	24.63	30.00	H	-5.37
	1732.50	-13.30	-29.60	8.10	24.40	30.00	H	-5.60
	1745.00	-13.56	-29.50	8.10	24.04	30.00	H	-5.96

Remark:EIRP=PMea-Pcl-PAg+Ga Antenna Gain.

LTE BAND 5 QPSK-5MHz	Frequency (MHz)	PMea (dBm)	Pcl(dB)+PA g(dB)	Ga Antenna Gain (dBi)	Correction (dB)	ERP (dBm)	Limit (dBm)	Polarity	Margin (dB)
	826.50	-9.24	-33.60	-0.84	2.15	21.37	38.45	H	-17.08
	836.50	-9.33	-33.50	-0.74	2.15	21.28	38.45	H	-17.17
	846.50	-8.89	-33.50	-0.73	2.15	21.73	38.45	H	-16.72
LTE BAND 5 QPSK-10MHz	Frequency (MHz)	PMea (dBm)	Pcl(dB)+P Ag(dB)	Ga Antenna Gain(dBi)	Correction (dB)	ERP (dBm)	Limit (dBm)	Polarity	Margin (dB)
	829.00	-8.93	-33.60	-0.84	2.15	21.68	38.45	H	-16.77
	836.50	-9.36	-33.50	-0.74	2.15	21.25	38.45	H	-17.20
	844.00	-9.16	-33.50	-0.78	2.15	21.41	38.45	H	-17.04
LTE BAND 5 16QAM-5MHz	Frequency (MHz)	PMea (dBm)	Pcl(dB)+P Ag(dB)	Ga Antenna Gain(dBi)	Correction (dB)	ERP (dBm)	Limit (dBm)	Polarity	Margin (dB)
	826.50	-9.41	-33.60	-0.84	2.15	21.20	38.45	H	-17.25
	836.50	-9.37	-33.50	-0.74	2.15	21.24	38.45	H	-17.21
	846.50	-8.88	-33.50	-0.73	2.15	21.74	38.45	H	-16.71
LTE BAND 5 16QAM-10MHz	Frequency (MHz)	PMea (dBm)	Pcl(dB)+P Ag(dB)	Ga Antenna Gain(dBi)	Correction (dB)	ERP (dBm)	Limit (dBm)	Polarity	Margin (dB)
	829.00	-9.05	-33.60	-0.84	2.15	21.56	38.45	H	-16.89
	836.50	-9.42	-33.50	-0.74	2.15	21.19	38.45	H	-17.26
	844.00	-9.15	-33.50	-0.78	2.15	21.42	38.45	H	-17.03

Remark: ERP=PMea-Pcl-PAg+Ga Antenna Gain-Correction.

LTE BAND 7 QPSK-5MHz	Frequency (MHz)	PMea (dBm)	Pcl(dB)+PA g(dB)	Ga Antenna Gain (dBi)	EIRP (dBm)	Limit (dBm)	Polarity	Margin (dB)
	2502.50	-15.32	-28.70	10.70	24.08	33.00	H	-8.92
	2535.00	-14.58	-28.60	10.70	24.72	33.00	H	-8.28
	2567.50	-14.73	-28.60	10.70	24.57	33.00	H	-8.43
LTE BAND 7 QPSK-10MHz	Frequency (MHz)	PMea (dBm)	Pcl(dB)+P Ag(dB)	Ga Antenna Gain(dBi)	EIRP (dBm)	Limit (dBm)	Polarity	Margin (dB)
	2505.00	-15.12	-28.70	10.70	24.28	33.00	H	-8.72
	2535.00	-15.08	-28.60	10.70	24.22	33.00	H	-8.78
	2565.00	-14.88	-28.60	10.70	24.42	33.00	H	-8.58
LTE BAND 7 QPSK-15MHz	Frequency (MHz)	PMea (dBm)	Pcl(dB)+PA g(dB)	Ga Antenna Gain (dBi)	EIRP (dBm)	Limit (dBm)	Polarity	Margin (dB)
	2507.50	-15.29	-28.70	10.70	24.11	33.00	H	-8.89
	2535.00	-14.52	-28.60	10.70	24.78	33.00	H	-8.22
	2562.50	-14.89	-28.60	10.70	24.41	33.00	H	-8.59
LTE BAND 7 QPSK-20MHz	Frequency (MHz)	PMea (dBm)	Pcl(dB)+P Ag(dB)	Ga Antenna Gain(dBi)	EIRP (dBm)	Limit (dBm)	Polarity	Margin (dB)
	2510.00	-14.73	-28.70	10.70	24.67	33.00	H	-8.33
	2535.00	-14.89	-28.60	10.70	24.41	33.00	H	-8.59
	2560.00	-14.71	-28.60	10.70	24.59	33.00	H	-8.41
LTE BAND 7 16QAM-5MHz	Frequency (MHz)	PMea (dBm)	Pcl(dB)+P Ag(dB)	Ga Antenna Gain(dBi)	EIRP (dBm)	Limit (dBm)	Polarity	Margin (dB)
	2502.50	-15.19	-28.70	10.70	24.21	33.00	H	-8.79
	2535.00	-14.65	-28.60	10.70	24.65	33.00	H	-8.35
	2567.50	-14.42	-28.60	10.70	24.88	33.00	H	-8.12
LTE BAND 7 16QAM-10MHz	Frequency (MHz)	PMea (dBm)	Pcl(dB)+P Ag(dB)	Ga Antenna Gain(dBi)	EIRP (dBm)	Limit (dBm)	Polarity	Margin (dB)
	2505.00	-15.30	-28.70	10.70	24.10	33.00	H	-8.90
	2535.00	-14.73	-28.60	10.70	24.57	33.00	H	-8.43
	2565.00	-14.36	-28.60	10.70	24.94	33.00	H	-8.06
LTE BAND 7 16QAM-15MHz	Frequency (MHz)	PMea (dBm)	Pcl(dB)+P Ag(dB)	Ga Antenna Gain(dBi)	EIRP (dBm)	Limit (dBm)	Polarity	Margin (dB)
	2507.50	-15.18	-28.70	10.70	24.22	33.00	H	-8.78
	2535.00	-14.89	-28.60	10.70	24.41	33.00	H	-8.59
	2562.50	-14.32	-28.60	10.70	24.98	33.00	H	-8.02
LTE BAND 7 16QAM-20MHz	Frequency (MHz)	PMea (dBm)	Pcl(dB)+P Ag(dB)	Ga Antenna Gain(dBi)	EIRP (dBm)	Limit (dBm)	Polarity	Margin (dB)
	2510.00	-14.99	-28.70	10.70	24.41	33.00	H	-8.59
	2535.00	-14.65	-28.60	10.70	24.65	33.00	H	-8.35
	2560.00	-14.38	-28.60	10.70	24.92	33.00	H	-8.08

Remark:EIRP=PMea-Pcl-PAg+Ga Antenna Gain.

4.9 Field strength of spurious radiation measurement

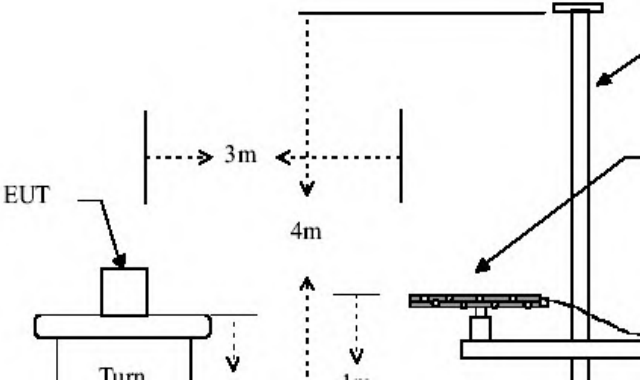
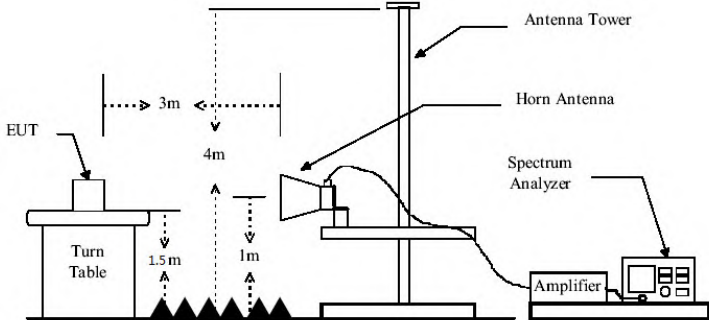
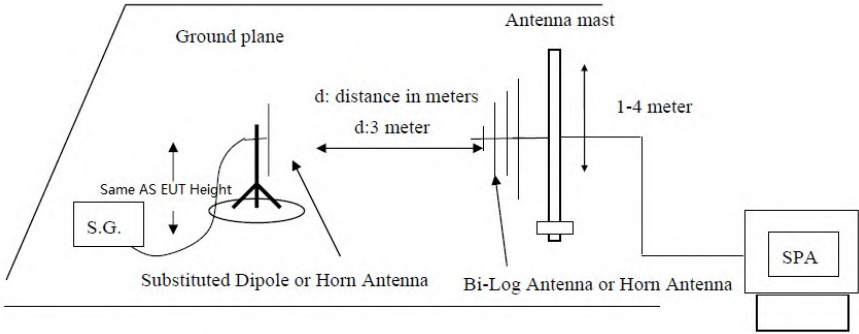
<p>Test Requirement:</p>	<p>FCC part22.913(a), FCC part24.238(a), FCC part27.53 and RSS-132 (5.5), RSS-133 (6.5.1), RSS-139(6.6) and RSS-199(4.5)</p>
<p>Test Method:</p>	<p>KDB 971168 D01 v03r1 clause 7, FCC part2.1051, ANSI/TIA-603-E, ANSI C63.26 clause 5.5</p>
<p>Limit:</p>	<p>Band 2/4/5/12/13/25:-13dBm Band 7:-25dBm</p>
<p>Test setup:</p>	<p>Below 1GHz</p>  <p>Above 1GHz</p>  <p>Substituted method:</p> 

Test Procedure:	<ol style="list-style-type: none"> 1. The EUT was placed on a non-conductive turntable using a non-conductive support. The radiated emission at the fundamental frequency was measured at 3 m with a test antenna and EMI spectrum analyzer. 2. During the tests, the antenna height and the EUT azimuth were varied in order to identify the maximum level of emissions from the EUT. This maximization process was repeated with the EUT positioned in each of its three orthogonal orientations. 3. The frequency range up to tenth harmonic was investigated for each of three fundamental frequency (low, middle and high channels). Once spurious emission was identified, the power of the emission was determined using the substitution method. 4. The spurious emissions attenuation was calculated as the difference between radiated power at the fundamental frequency and the spurious emissions frequency. $\text{ERP / EIRP} = \text{S.G. output (dBm)} + \text{Antenna Gain(dB/dBi)} - \text{Cable Loss (dB)}$
Test Instruments:	Refer to section 3 for details
Test mode:	Refer to section 4.1 for details
Test results:	Pass

Measurement Data

QPSK Mode:

Test mode:		LTE Band 2(5MHz)		Test channel:	Lowest
Frequency (MHz)	Spurious Emission		Limit (dBm)	Result	
	Polarization	Level (dBm)			
3701.40	Vertical	-35.64	-13.00	Pass	
5552.10	V	-39.52			
7402.80	V	-38.90			
9253.50	V	-42.57			
11104.20	V	-47.59			
3701.40	Horizontal	-39.48	-13.00	Pass	
5552.10	H	-44.66			
7402.80	H	-46.10			
9253.50	H	-48.97			
11104.20	H	-53.25			
Test mode:		LTE Band 2(5MHz)		Test channel:	Middle
Frequency (MHz)	Spurious Emission		Limit (dBm)	Result	
	Polarization	Level (dBm)			
3760.00	Vertical	-35.52	-13.00	Pass	
5640.00	V	-39.08			
7520.00	V	-38.80			
9400.00	V	-42.76			
11280.00	V	-48.35			
3760.00	Horizontal	-39.66	-13.00	Pass	
5640.00	H	-45.25			
7520.00	H	-46.00			
9400.00	H	-49.16			
11280.00	H	-53.54			
Test mode:		LTE Band 2(5MHz)		Test channel:	Highest
Frequency (MHz)	Spurious Emission		Limit (dBm)	Result	
	Polarization	Level (dBm)			
3818.60	Vertical	-35.27	-13.00	Pass	
5727.90	V	-39.23			
7637.20	V	-39.04			
9546.50	V	-42.69			
11455.80	V	-48.34			
3818.60	Horizontal	-39.95	-13.00	Pass	
5727.90	H	-45.27			
7637.20	H	-46.54			
9546.50	H	-48.40			
11455.80	H	-54.21			

Remark :

1. The emission behaviour belongs to narrowband spurious emission, all modes investigated and only worst case is reported.
2. Remark"---" means that the emission level is too low (20dB lower than the limit) to be measured
3. The emission levels of below 1 GHz are very lower (20dB lower than the limit) than the limit and not show in test report.

Test mode:	LTE Band 4(5MHz)		Test channel:	Lowest
Frequency (MHz)	Spurious Emission		Limit (dBm)	Result
	Polarization	Level (dBm)		
3421.40	Vertical	-36.08	-13.00	Pass
5132.10	V	-38.60		
6842.80	V	-38.42		
8553.50	V	-43.32		
10264.20	V	-47.51		
3421.40	Horizontal	-39.42	-13.00	Pass
5132.10	H	-44.98		
6842.80	H	-46.72		
8553.50	H	-48.39		
10264.20	H	-53.74		
Test mode:	LTE Band 4(5MHz)		Test channel:	Middle
Frequency (MHz)	Spurious Emission		Limit (dBm)	Result
	Polarization	Level (dBm)		
3465.00	Vertical	-35.95	-13.00	Pass
5197.50	V	-39.37		
6930.00	V	-38.36		
8662.50	V	-43.33		
10395.00	V	-47.72		
3465.00	Horizontal	-39.07	-13.00	Pass
5197.50	H	-45.09		
6930.00	H	-46.50		
8662.50	H	-49.17		
10395.00	H	-53.94		
Test mode:	LTE Band 4(5MHz)		Test channel:	Highest
Frequency (MHz)	Spurious Emission		Limit (dBm)	Result
	Polarization	Level (dBm)		
3508.60	Vertical	-35.18	-13.00	Pass
5262.90	V	-38.63		
7017.20	V	-38.27		
8771.50	V	-42.56		
10525.80	V	-48.04		
3508.60	Horizontal	-39.60	-13.00	Pass
5262.90	H	-44.69		
7017.20	H	-46.10		
8771.50	H	-49.12		
10525.80	H	-53.59		

Remark:

1. The emission behaviour belongs to narrowband spurious emission, all modes investigated and only worst case is reported.
2. Remark"---" means that the emission level is too low (20dB lower than the limit) to be measured
3. The emission levels of below 1 GHz are very lower (20dB lower than the limit) than the limit and not show in test report.

Test mode:	LTE Band 5(5MHz)		Test channel:	Lowest
Frequency (MHz)	Spurious Emission		Limit (dBm)	Result
	Polarization	Level (dBm)		
1649.40	Vertical	-35.57	-13.00	Pass
2474.10	V	-38.93		
3298.80	V	-38.95		
4123.50	V	-43.12		
4948.20	V	-48.04		
1649.40	Horizontal	-39.47	-13.00	Pass
2474.10	H	-44.94		
3298.80	H	-46.44		
4123.50	H	-48.71		
4948.20	H	-53.86		
Test mode:	LTE Band 5(5MHz)		Test channel:	Middle
Frequency (MHz)	Spurious Emission		Limit (dBm)	Result
	Polarization	Level (dBm)		
1673.00	Vertical	-35.65	-13.00	Pass
2509.50	V	-39.44		
3346.00	V	-38.61		
4182.50	V	-42.57		
5019.00	V	-47.69		
1673.00	Horizontal	-39.43	-13.00	Pass
2509.50	H	-44.93		
3346.00	H	-46.11		
4182.50	H	-48.68		
5019.00	H	-54.20		
Test mode:	LTE Band 5(5MHz)		Test channel:	Highest
Frequency (MHz)	Spurious Emission		Limit (dBm)	Result
	Polarization	Level (dBm)		
1696.60	Vertical	-35.66	-13.00	Pass
2544.90	V	-38.80		
3393.20	V	-38.44		
4241.50	V	-42.56		
5089.80	V	-47.66		
1696.60	Horizontal	-39.08	-13.00	Pass
2544.90	H	-44.36		
3393.20	H	-46.66		
4241.50	H	-48.99		
5089.80	H	-54.02		

Remark :

4. The emission behaviour belongs to narrowband spurious emission, all modes investigated and only worst case is reported.
5. Remark"---" means that the emission level is too low (20dB lower than the limit) to be measured
4. The emission levels of below 1 GHz are very lower (20dB lower than the limit) than the limit and not show in test report.

Test mode:	LTE Band 7(5MHz)		Test channel:	Lowest
Frequency (MHz)	Spurious Emission		Limit (dBm)	Result
	Polarization	Level (dBm)		
5005.00	Vertical	-36.01	-25.00	Pass
7507.50	V	-38.59		
10010.00	V	-39.06		
12512.50	V	-43.46		
15015.00	V	-47.90		
5005.00	Horizontal	-39.48	-25.00	Pass
7507.50	H	-44.57		
10010.00	H	-46.31		
12512.50	H	-48.43		
15015.00	H	-53.84		
Test mode:	LTE Band 7(5MHz)		Test channel:	Middle
Frequency (MHz)	Spurious Emission		Limit (dBm)	Result
	Polarization	Level (dBm)		
5070.00	Vertical	-35.58	-25.00	Pass
7605.00	V	-39.42		
10140.00	V	-38.17		
12675.00	V	-42.80		
15210.00	V	-47.61		
5070.00	Horizontal	-39.80	-25.00	Pass
7605.00	H	-44.61		
10140.00	H	-46.39		
12675.00	H	-48.26		
15210.00	H	-53.95		
Test mode:	LTE Band 7(5MHz)		Test channel:	Highest
Frequency (MHz)	Spurious Emission		Limit (dBm)	Result
	Polarization	Level (dBm)		
5135.00	Vertical	-35.99	-25.00	Pass
7702.50	V	-38.83		
10270.00	V	-38.78		
12837.50	V	-42.85		
15405.00	V	-47.50		
5135.00	Horizontal	-39.50	-25.00	Pass
7702.50	H	-44.54		
10270.00	H	-46.49		
12837.50	H	-49.21		
15405.00	H	-53.32		

Remark :

1. The emission behaviour belongs to narrowband spurious emission, all modes investigated and only worst case is reported.
2. Remark"---" means that the emission level is too low (20dB lower than the limit) to be measured
3. The emission levels of below 1 GHz are very lower (20dB lower than the limit) than the limit and not show in test report.

16 QAM Mode:

Test mode:		LTE Band 2 (1.4MHz)		Test channel:	Lowest
Frequency (MHz)	Spurious Emission		Limit (dBm)	Result	
	Polarization	Level (dBm)			
3701.40	Vertical	-35.57	-13.00	Pass	
5552.10	V	-38.69			
7402.80	V	-38.42			
9253.50	V	-42.50			
11104.20	V	-47.86			
3701.40	Horizontal	-39.92	-13.00	Pass	
5552.10	H	-44.72			
7402.80	H	-46.06			
9253.50	H	-48.95			
11104.20	H	-54.19			
Test mode:		LTE Band 2 (1.4MHz)		Test channel:	Middle
Frequency (MHz)	Spurious Emission		Limit (dBm)	Result	
	Polarization	Level (dBm)			
3760.00	Vertical	-35.20	-13.00	Pass	
5640.00	V	-38.88			
7520.00	V	-38.53			
9400.00	V	-42.66			
11280.00	V	-47.42			
3760.00	Horizontal	-39.58	-13.00	Pass	
5640.00	H	-44.47			
7520.00	H	-45.89			
9400.00	H	-48.83			
11280.00	H	-53.96			
Test mode:		LTE Band 2 (1.4MHz)		Test channel:	Highest
Frequency (MHz)	Spurious Emission		Limit (dBm)	Result	
	Polarization	Level (dBm)			
3818.60	Vertical	-35.95	-13.00	Pass	
5727.90	V	-38.61			
7637.20	V	-38.26			
9546.50	V	-43.21			
11455.80	V	-47.85			
3818.60	Horizontal	-39.81	-13.00	Pass	
5727.90	H	-44.75			
7637.20	H	-46.02			
9546.50	H	-48.38			
11455.80	H	-54.21			

Remark :

- 1 The emission behaviour belongs to narrowband spurious emission, all modes investigated and only worst case is reported.
- 2 Remark"---" means that the emission level is too low (20dB lower than the limit) to be measured
- 3 The emission levels of below 1 GHz are very lower (20dB lower than the limit) than the limit and not show in test report.

Test mode:		LTE Band 4(1.4MHz)		Test channel:	Lowest
Frequency (MHz)	Spurious Emission		Limit (dBm)	Result	
	Polarization	Level (dBm)			
3421.40	Vertical	-35.83	-13.00	Pass	
5132.10	V	-39.13			
6842.80	V	-39.02			
8553.50	V	-42.93			
10264.20	V	-47.96			
3421.40	Horizontal	-39.86	-13.00	Pass	
5132.10	H	-45.11			
6842.80	H	-46.12			
8553.50	H	-48.88			
10264.20	H	-53.45			
Test mode:		LTE Band 4(1.4MHz)		Test channel:	Middle
Frequency (MHz)	Spurious Emission		Limit (dBm)	Result	
	Polarization	Level (dBm)			
3465.00	Vertical	-35.48	-13.00	Pass	
5197.50	V	-38.56			
6930.00	V	-38.82			
8662.50	V	-43.09			
10395.00	V	-47.77			
3465.00	Horizontal	-39.43	-13.00	Pass	
5197.50	H	-45.18			
6930.00	H	-46.70			
8662.50	H	-48.72			
10395.00	H	-53.95			
Test mode:		LTE Band 4(1.4MHz)		Test channel:	Highest
Frequency (MHz)	Spurious Emission		Limit (dBm)	Result	
	Polarization	Level (dBm)			
3508.60	Vertical	-35.22	-13.00	Pass	
5262.90	V	-39.28			
7017.20	V	-39.12			
8771.50	V	-43.25			
10525.80	V	-48.35			
3508.60	Horizontal	-39.62	-13.00	Pass	
5262.90	H	-45.24			
7017.20	H	-46.21			
8771.50	H	-48.80			
10525.80	H	-54.10			

Remark:

- 1 The emission behaviour belongs to narrowband spurious emission, all modes investigated and only worst case is reported.
- 2 Remark"---" means that the emission level is too low (20dB lower than the limit) to be measured
- 3 The emission levels of below 1 GHz are very lower (20dB lower than the limit) than the limit and not show in test report.

Test mode:		LTE Band 5(1.4MHz)		Test channel:	Lowest
Frequency (MHz)	Spurious Emission		Limit (dBm)	Result	
	Polarization	Level (dBm)			
1649.40	Vertical	-35.51	-13.00	Pass	
2474.10	V	-38.86			
3298.80	V	-38.72			
4123.50	V	-42.56			
4948.20	V	-48.04			
1649.40	Horizontal	-39.81	-13.00	Pass	
2474.10	H	-44.83			
3298.80	H	-46.60			
4123.50	H	-49.08			
4948.20	H	-54.06			
Test mode:		LTE Band 5(1.4MHz)		Test channel:	Middle
Frequency (MHz)	Spurious Emission		Limit (dBm)	Result	
	Polarization	Level (dBm)			
1673.00	Vertical	-35.74	-13.00	Pass	
2509.50	V	-38.86			
3346.00	V	-38.65			
4182.50	V	-43.44			
5019.00	V	-47.48			
1673.00	Horizontal	-39.08	-13.00	Pass	
2509.50	H	-45.21			
3346.00	H	-46.58			
4182.50	H	-48.36			
5019.00	H	-53.49			
Test mode:		LTE Band 5(1.4MHz)		Test channel:	Highest
Frequency (MHz)	Spurious Emission		Limit (dBm)	Result	
	Polarization	Level (dBm)			
1696.60	Vertical	-35.17	-13.00	Pass	
2544.90	V	-38.80			
3393.20	V	-38.47			
4241.50	V	-43.21			
5089.80	V	-48.34			
1696.60	Horizontal	-39.89	-13.00	Pass	
2544.90	H	-45.01			
3393.20	H	-45.95			
4241.50	H	-48.55			
5089.80	H	-54.02			

Remark :

- 1 The emission behaviour belongs to narrowband spurious emission, all modes investigated and only worst case is reported.
- 2 Remark"---" means that the emission level is too low (20dB lower than the limit) to be measured
- 3 The emission levels of below 1 GHz are very lower (20dB lower than the limit) than the limit and not show in test report.

Test mode:	LTE Band 7(5MHz)		Test channel:	Lowest
Frequency (MHz)	Spurious Emission		Limit (dBm)	Result
	Polarization	Level (dBm)		
5005.00	Vertical	-35.44	-25.00	Pass
7507.50	V	-39.53		
10010.00	V	-38.23		
12512.50	V	-43.38		
15015.00	V	-48.11		
5005.00	Horizontal	-39.57	-25.00	Pass
7507.50	H	-44.50		
10010.00	H	-46.36		
12512.50	H	-48.36		
15015.00	H	-53.54		
Test mode:	LTE Band 7(5MHz)		Test channel:	Middle
Frequency (MHz)	Spurious Emission		Limit (dBm)	Result
	Polarization	Level (dBm)		
5070.00	Vertical	-35.94	-25.00	Pass
7605.00	V	-39.44		
10140.00	V	-38.60		
12675.00	V	-42.93		
15210.00	V	-47.77		
5070.00	Horizontal	-39.35	-25.00	Pass
7605.00	H	-44.79		
10140.00	H	-46.27		
12675.00	H	-48.64		
15210.00	H	-54.07		
Test mode:	LTE Band 7(5MHz)		Test channel:	Highest
Frequency (MHz)	Spurious Emission		Limit (dBm)	Result
	Polarization	Level (dBm)		
5135.00	Vertical	-35.85	-25.00	Pass
7702.50	V	-39.27		
10270.00	V	-38.28		
12837.50	V	-42.85		
15405.00	V	-48.07		
5135.00	Horizontal	-39.17	-25.00	Pass
7702.50	H	-44.44		
10270.00	H	-46.75		
12837.50	H	-48.51		
15405.00	H	-54.21		

Remark :

- 1 The emission behaviour belongs to narrowband spurious emission, all modes investigated and only worst case is reported.
- 2 Remark"---" means that the emission level is too low (20dB lower than the limit) to be measured
- 3 The emission levels of below 1 GHz are very lower (20dB lower than the limit) than the limit and not show in test report.

4.10 Frequency stability V.S. Temperature measurement

Test Requirement:	FCC Part2.1055(a)(1)(b), Part 22.355, Part 24.235, Part 27.54, RSS-132 (5.3), RSS-133 (6.3), RSS-139(6.4) and RSS-199(4.3)
Test Method:	FCC Part2.1055(a)(1)(b), ANSI/TIA-603-E FCC KDB971168 D01 v03r01 Section 8, ANSI C63.26 clause 5.6.
Limit:	2.5ppm(Part 22) Within the authorized bands of operation(Part 24, Part 27)
Test setup:	<div style="text-align: center;"> <p>The diagram shows a block diagram of the test setup. On the left is a 'Spectrum analyzer' box containing a small graph. A line connects it to an 'Att.' (attenuator) box. From the 'Att.' box, a line goes to the 'EUT' (Equipment Under Test) box, which is located inside a larger box labeled 'Temperature Chamber'. Below the 'EUT' box, another line connects to a 'Variable Power Supply' box.</p> </div> <p>Note : Measurement setup for testing on Antenna connector</p>
Test procedure:	<ol style="list-style-type: none"> 1. The equipment under test was connected to an external DC power supply and input rated voltage. 2. RF output was connected to a frequency counter or spectrum analyzer via feed through attenuators. 3. The EUT was placed inside the temperature chamber. 4. Set the spectrum analyzer RBW low enough to obtain the desired frequency resolution and measure EUT 25°C operating frequency as reference frequency. 5. Turn EUT off and set the chamber temperature to -20°C. After the temperature stabilized for approximately 30 minutes recorded the frequency. 6. Repeat step measure with 10°C increased per stage until the highest temperature of +50°C reached.
Test Instruments:	Refer to section 3 for details
Test mode:	Refer to section 4.1 for details
Test results:	Pass
Remark:	If all frequencies stability are comply with the lower limit, then all results can be considered qualified

Measurement Data

Reference Frequency: LTE Band 2 Middle channel=18900 channel=1880MHz					
Power supplied (Vdc)	Temperature (°C)	Frequency error		Limit (ppm)	Result
		Hz	ppm		
7.4	-20	14	0.0076	±2.5	Pass
	-10	-32	-0.0170		
	0	13	0.0070		
	10	-27	-0.0146		
	20	9	0.0048		
	30	11	0.0058		
	40	-9	-0.0048		
	50	5	0.0026		
Reference Frequency: LTE Band 4 Middle channel=20175 channel=1732.5MHz					
Power supplied (Vdc)	Temperature (°C)	Frequency error		Limit (ppm)	Result
		Hz	ppm		
7.4	-20	12	0.0068	±2.5	Pass
	-10	-24	-0.0141		
	0	22	0.0130		
	10	-33	-0.0188		
	20	11	0.0064		
	30	11	0.0066		
	40	-14	-0.0079		
	50	7	0.0042		
Reference Frequency: LTE Band 5 Middle channel=20175 channel=836.5MHz					
Power supplied (Vdc)	Temperature (°C)	Frequency error		Limit (ppm)	Result
		Hz	ppm		
7.4	-20	19	0.0230	±2.5	Pass
	-10	-18	-0.0218		
	0	11	0.0126		
	10	-31	-0.0372		
	20	13	0.0159		
	30	10	0.0122		
	40	7	0.0089		
	50	-29	-0.0341		

Reference Frequency: LTE Band 7 Middle channel=21100 channel=2535MHz					
Power supplied (Vdc)	Temperature (°C)	Frequency error		Limit (ppm)	Result
		Hz	ppm		
7.4	-20	15	0.0058	±2.5	Pass
	-10	-24	-0.0096		
	0	24	0.0093		
	10	-27	-0.0105		
	20	15	0.0058		
	30	14	0.0054		
	40	-7	-0.0028		
	50	5	0.0019		

4.11 Frequency stability V.S. Voltage measurement

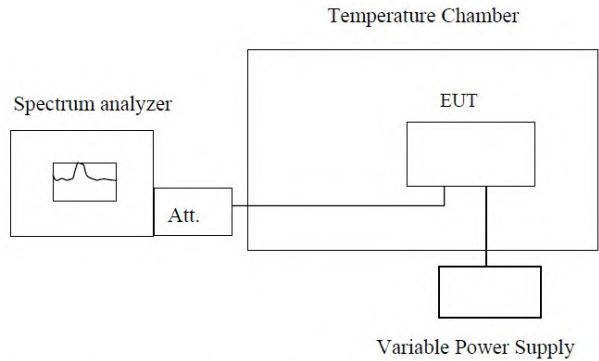
Test Requirement:	FCC Part2.1055(d)(1)(2), Part 22.355, Part 24.235, Part 27.54, RSS-132 (5.3), RSS-133 (6.3), RSS-139(6.4) and RSS-199(4.3)
Test Method:	FCC Part2.1055(d)(1)(2), ANSI/TIA-603-E FCC KDB971168 D01 v03r01 Section 8, ANSI C63.26 clause 5.6.
Limit:	2.5ppm
Test setup:	 <p style="text-align: center;">Temperature Chamber</p> <p style="text-align: center;">Spectrum analyzer Att. EUT</p> <p style="text-align: center;">Variable Power Supply</p> <p>Note : Measurement setup for testing on Antenna connector</p>
Test procedure:	<ol style="list-style-type: none"> 1. Set chamber temperature to 20°C. Use a variable DC power source to power the EUT and set the voltage to rated voltage. 2. Set the spectrum analyzer RBW low enough to obtain the desired frequency resolution and recorded the frequency. 3. Reduce the input voltage to specified extreme voltage variation (+/- 15%) and endpoint, record the maximum frequency change.
Test Instruments:	Refer to section 3 for details
Test mode:	Refer to section 4.1 for details
Test results:	Pass
Remark:	<ol style="list-style-type: none"> 1. Manufacturer specified the battery operating end point voltage is 6.1VDC, max voltage is 8.3VDC. 2. If all frequencies stability are comply with the lower limit, then all results can be considered qualified

Measurement Data

Reference Frequency: LTE Band 2 Middle channel=18900 channel=1880MHz					
Temperature (°C)	Power supplied (Vdc)	Frequency error		Limit (ppm)	Result
		Hz	ppm		
20	8.5	6	0.0029	±2.5	Pass
	7.4	15	0.0079		
	6.3	-22	-0.0117		
Reference Frequency: LTE Band 4 Middle channel=20175 channel=1732.5MHz					
Temperature (°C)	Power supplied (Vdc)	Frequency error		Limit (ppm)	Result
		Hz	ppm		
20	8.5	12	0.0068	±2.5	Pass
	7.4	-8	-0.0047		
	6.3	1	0.0003		
Reference Frequency: LTE Band 5 Middle channel=20175 channel=836.5MHz					
Temperature (°C)	Power supplied (Vdc)	Frequency error		Limit (ppm)	Result
		Hz	ppm		
20	8.5	14	0.0170	±2.5	Pass
	7.4	-25	-0.0294		
	6.3	21	0.0247		
Reference Frequency: LTE Band 7 Middle channel=21100 channel=2535MHz					
Temperature (°C)	Power supplied (Vdc)	Frequency error		Limit (ppm)	Result
		Hz	ppm		
20	8.5	8	0.0033	±2.5	Pass
	7.4	12	0.0048		
	6.3	-14	-0.0056		

----- **END OF REPORT** -----