



# **FCC&IC TEST REPORT**

FCC ID: SY4-A02029

**On Behalf of**

Shanghai Huace Navigation Technology LTD.

Geodetic GNSS Receiver

Model No.: P5

Prepared for : Shanghai Huace Navigation Technology LTD.  
Address : 599 Gaojing Road, Building D, Shanghai 201702, China

Prepared By : Shenzhen Alpha Product Testing Co., Ltd.  
Address : Building i, No.2, Lixin Road, Fuyong Street, Bao'an District,  
518103, Shenzhen, Guangdong, China

Report Number : A2102016-C01-R04  
Date of Receipt : February 20, 2021  
Date of Test : February 20, 2021 – March 15, 2021  
Date of Report : March 15, 2021  
Version Number : V0

---

## Contents

Page

<b>1</b>	<b>TEST SUMMARY .....</b>	<b>5</b>
<b>2</b>	<b>GENERAL INFORMATION .....</b>	<b>7</b>
2.1	GENERAL DESCRIPTION OF EUT .....	7
2.2	RELATED SUBMITTAL(S) / GRANT (S) .....	9
2.3	TEST FACILITY.....	9
2.4	MEASUREMENT UNCERTAINTY .....	9
<b>3</b>	<b>TEST INSTRUMENTS LIST .....</b>	<b>10</b>
<b>4</b>	<b>SYSTEM TEST CONFIGURATION.....</b>	<b>11</b>
4.1	TEST MODE.....	11
4.2	CONFIGURATION OF TESTED SYSTEM .....	11
4.3	CONDUCTED AV OUTPUT POWER .....	12
4.4	PEAK-TO-AVERAGE RATIO .....	14
4.5	OCCUPY BANDWIDTH.....	18
4.6	MODULATION CHARACTERISTIC.....	23
4.7	OUT OF BAND EMISSION AT ANTENNA TERMINALS .....	23
4.8	ERP, EIRP MEASUREMENT.....	32
4.9	FIELD STRENGTH OF SPURIOUS RADIATION MEASUREMENT .....	35
4.10	FREQUENCY STABILITY V.S. TEMPERATURE MEASUREMENT .....	43
4.11	FREQUENCY STABILITY V.S. VOLTAGE MEASUREMENT.....	47

### TEST REPORT DECLARATION

Applicant : Shanghai Huace Navigation Technology LTD.  
 Address : 599 Gaojing Road, Building D, Shanghai 201702, China  
 Manufacturer : Shanghai Huace Navigation Technology LTD.  
 Address : 599 Gaojing Road, Building D, Shanghai 201702, China  
 EUT Description : Geodetic GNSS Receiver  
 (A) Model No. : P5  
 (B) Trademark : 

Measurement Standard Used:

- FCC CFR Title 47 Part 2
- FCC CFR Title 47 Part22 Subpart H
- FCC CFR Title 47 Part24 Subpart E
- FCC CFR Title 47 Part27 Subpart C
- RSS-132 Issue 3 January 2013
- RSS-133 Issue 6 January 2018
- RSS-139 Issue 3, July 2015
- RSS-Gen Issue 5, April 2018
- ANSIC 63.26:2015, TIA/EIA-603-E:2016

The device described above is tested by Shenzhen Alpha Product Testing Co., Ltd. to determine the maximum emission levels emanating from the device. The test results are contained in this test report and Shenzhen Alpha Product Testing Co., Ltd. is assumed of full responsibility for the accuracy and completeness of these tests.

After the test, our opinion is that EUT compliance with the requirement of the above standards.

This report applies to above tested sample only. This report shall not be reproduced in parts without written approval of Shenzhen Alpha Product Testing Co., Ltd.

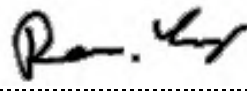
Tested by (name + signature).....: Reak Yang   
 Project Engineer

Approved by (name + signature).....: Simple Guan   
 Project Manager

Date of issue..... : March 15, 2021

**Revision History**

Revision	Issue Date	Revisions	Revised By
V0	March 15, 2021	Initial released Issue	Reak Yang

## 1 Test Summary

Test Item	Section in CFR 47	Result
RF Exposure (SAR)	Part 2.1310 Part 2.1091 RSS-102 Issue 5	Pass* (Please refer to SAR Report)
RF Output Power	Part 2.1046 Part 22.913 (a)(2) Part 24.232 (c) Part 27.50(d)(4) RSS-132 Issue 3, January 2013(5.4) RSS-133 Issue 6, January 2018(4.1) RSS-139 Issue 3, January 2015(4.1)	Pass
Peak-to-Average Ratio	Part 2.1046 Part 22.913(d) Part 24.232 (d) Part 27.50(d)(5) RSS-132 Issue 3, January 2013(5.4) RSS-133 Issue 6, January 2018(6.4) RSS-139 Issue 3, January 2015(6.5)	Pass
Modulation Characteristics	Part 2.1047 RSS-132 Issue 3, January 2013(5.2) RSS-133 Issue 6, January 2018(6.2) RSS-139 Issue 3, January 2015(6.2)	Pass
99% & -26 dB Occupied Bandwidth	Part 2.1049 Part 22.917 Part 24.238 Part 27.53(h) RSS-132 Issue 3, January 2013(3.1) RSS-133 Issue 6, January 2018(2.3) RSS-139 Issue 3, January 2015(2.3)	Pass
Spurious Emissions at Antenna Terminal	Part 2.1051 Part 22.917 (a) Part 24.238 (a) Part 27.53(h) RSS-132 Issue 3, January 2013(5.5) RSS-133 Issue 6, January 2018(6.5) RSS-139 Issue 3, January 2015(6.6)	Pass
Field Strength of Spurious Radiation	Part 2.1053 Part 22.917 (a) Part 24.238 (a) Part 27.53(h) RSS-132 Issue 3, January 2013(5.5) RSS-133 Issue 6, January 2018(6.5) RSS-139 Issue 3, January 2015(6.6)	Pass
Out of band emission, Band Edge	Part 22.917 (a) Part 24.238 (a) Part 27.53(h) RSS-132 Issue 3, January 2013(5.5) RSS-133 Issue 6, January 2018(6.5) RSS-139 Issue 3, January 2015(6.6)	Pass
Frequency stability vs. temperature	Part 2.1055(a)(1)(b) Part 22.355, Part 24.235, Part 27.54 RSS-132 Issue 3, January 2013(5.3) RSS-133 Issue 6, January 2018(6.3) RSS-139 Issue 3, January 2015(6.4)	Pass

Frequency stability vs. voltage	Part 2.1055(d)(1)(2) Part 22.355, Part 24.235, Part 27.54 RSS-132 Issue 3, January 2013(5.3) RSS-133 Issue 6, January 2018(6.3) RSS-139 Issue 3, January 2015(6.4)	Pass
---------------------------------	--	------

*Pass: The EUT complies with the essential requirements in the standard.*

## 2 General Information

### 2.1 General Description of EUT

Description/PMN	: Geodetic GNSS Receiver
Model Number/HVIN(s)	: P5
Diff	: N/A
Trademark	: 
Test Voltage	: DC 7.4V from battery or 12-36VDC, DC 12V From adapter
Support Networks	: GPRS, EGPRS, WCDMA
Support Bands	: GSM850, PCS1900, WCDMA Band V, WCDMA Band II
TX Frequency	: GSM850: 824.20MHz-848.80MHz PCS1900: 1850.20MHz-1909.80MHz WCDMA Band V: 826.40MHz -846.60MHz WCDMA Band II: 1852.40MHz -1907.60MHz
GPRS Class	: 12
EGPRS Class	: 12
Modulation type	: GPRS: GMSK EGPRS: GMSK/8PSK WCDMA Band II/V: QPSK
Antenna type	: External antenna
Antenna gain	: External Antenna, Maximum Gain is 0.5dBi for GSM External Antenna, Maximum Gain is 0.5dBi for WCDMA
Software version	: V1.2.21
Hardware version/FVIN	: V2.0

Remark: The worst-case simultaneous transmission configuration was evaluated with no non-compliance found. Results in this report are only for 2G and 3G function, and there is no other transmitter involved.

**Operation Frequency List:**

GSM 850		PCS1900		WCDMA Band V		WCDMA Band II	
Channel	Frequency (MHz)	Channel	Frequency (MHz)	Channel	Frequency (MHz)	Channel	Frequency (MHz)
128	824.20	512	1850.20	4132	826.40	9262	1852.40
129	824.40	513	1850.40	4133	826.60	9263	1852.60
· ∴	· ∴	· ∴	· ∴	· ∴	· ∴	· ∴	· ∴
189	836.40	660	1879.80	4181	836.20	9399	1879.80
190	836.60	661	1880.00	4182	836.40	9400	1880.00
191	836.80	662	1880.20	4183	836.60	9401	1880.20
· ∴	· ∴	· ∴	· ∴	· ∴	· ∴	· ∴	· ∴
250	848.60	809	1909.60	4232	846.40	9537	1907.40
251	848.80	810	1909.80	4233	846.60	9538	1907.60

Regards to the operating frequency range over 10 MHz, the Lowest frequency, the middle frequency, and the highest frequency of channel were selected to perform the test, and the selected channel see below:

**Final test channel:**

GSM 850		PCS1900		WCDMA Band II		WCDMA Band V	
Channel	Frequency (MHz)	Channel	Frequency (MHz)	Channel	Frequency (MHz)	Channel	Frequency (MHz)
128	824.20	512	1850.20	9262	1852.40	4132	826.40
190	836.60	661	1880.00	9400	1880.00	4183	836.60
251	848.80	810	1909.80	9538	1907.60	4233	846.60



## 2.2 Related Submittal(s) / Grant (s)

This submittal(s) (test report) is filing to comply with Section Part 2, Part 22 subpart H, Part 24 subpart E, Part 27 subpart C of the FCC CFR 47, RSS-Gen, RSS-132, RSS-133, RSS-139 Rules, KDB 971168 D01 v03r01, ANSI C63.26 and TIA/EIA-603-E.

## 2.3 Test Facility

Shenzhen Alpha Product Testing Co., Ltd  
Building i, No.2, Lixin Road, Fuyong Street, Bao'an District, 518103, Shenzhen, Guangdong, China

June 21, 2018 File on Federal Communication Commission  
Registration Number: 293961  
Designation Number: CN1236

July 15, 2019 Certificated by IC  
Registration Number: 12135A

## 2.4 Measurement Uncertainty

Item	Uncertainty
Uncertainty for Power point Conducted Emissions Test	2.74dB
Uncertainty for Radiation Emission test in 3m chamber (below 30MHz)	2.13 dB(Polarize: V)
	2.57dB(Polarize: H)
Uncertainty for Radiation Emission test in 3m chamber (30MHz to 1GHz)	3.77dB(Polarize: V)
	3.80dB(Polarize: H)
Uncertainty for Radiation Emission test in 3m chamber (1GHz to 25GHz)	4.16dB(Polarize: H)
	4.13dB(Polarize: V)
Uncertainty for radio frequency	$5.4 \times 10^{-8}$
Uncertainty for conducted RF Power	0.37dB
Uncertainty for temperature	0.2°C
Uncertainty for humidity	1%
Uncertainty for DC and low frequency voltages	0.06%

### 3 Test Instruments list

Equipment	Manufacture	Model No.	Serial No.	Last cal.	Cal Interval
9*6*6 anechoic chamber	CHENYU	9*6*6	N/A	2020.09.02	3Year
Spectrum analyzer	ROHDE&SCHWARZ	FSV40-N	102137	2020.09.02	1Year
Spectrum analyzer	Agilent	N9020A	MY499100060	2020.09.02	1Year
Receiver	ROHDE&SCHWARZ	ESR	1316.3003K03-102082-Wa	2020.09.02	1Year
Receiver	R&S	ESCI	101165	2020.09.02	1Year
Bilog Antenna	Schwarzbeck	VULB 9168	VULB9168-438	2020.04.12	2Year
Horn Antenna	SCHWARZBECK	BBHA 9120 D	BBHA 9120 D(1201)	2020.04.12	2Year
Active Loop Antenna	SCHWARZBECK	FMZB 1519B	00059	2019.09.07	2Year
Cable	Resenberger	N/A	No.1	2020.09.02	1Year
Cable	Resenberger	N/A	No.2	2020.09.02	1Year
Cable	Resenberger	N/A	No.3	2020.09.02	1Year
Pre-amplifier	HP	HP8347A	2834A00455	2020.09.02	1Year
Pre-amplifier	Agilent	8449B	3008A02664	2020.09.02	1Year
L.I.S.N.#1	Schwarzbeck	NSLK8126	8126466	2020.09.02	1Year
L.I.S.N.#2	ROHDE&SCHWARZ	ENV216	101043	2020.09.02	1 Year
20db Attenuator	ICPROBING	IATS1	82347	2020.09.02	1 Year
Horn Antenna	SCHWARZBECK	BBHA9170	00946	2019.09.07	2 Year
Preamplifier	SKET	LNPA_1840-50	SK2018101801	2020.09.02	1 Year
Power Meter	Agilent	E9300A	MY41496625	2020.09.02	1 Year
Power Sensor	DARE	RPR3006W	15100041SNO91	2020.09.02	1 Year
Temp. & Humid. Chamber	Weihuang	WHTH-1000-40-880	100631	2020.09.02	1 Year
Switching Mode Power Supply	JUNKE	JK12010S	20140927-6	2020.09.02	1 Year
Antenna	SCHWARZBECK	STLP9128E-special	STLP9128E s#139	N/A	NCR

## 4 System test configuration

### 4.1 Test mode

During all testing, EUT is in link mode with base station emulator at maximum power level. The spurious emission measurements were carried out in semi-anechoic chamber with 3-meter test range, and EUT is rotated on three test planes to find out the worst emission.

Test modes		
Band	Radiated	Conducted
GSM 850	<ul style="list-style-type: none"> <li>■ GPRS 1 link</li> <li>■ EPRS 1 link</li> </ul>	<ul style="list-style-type: none"> <li>■ GPRS 1 link</li> <li>■ EGPRS 1 link</li> </ul>
PCS 1900	<ul style="list-style-type: none"> <li>■ GPRS 1 link</li> <li>■ EGPRS 1 link</li> </ul>	<ul style="list-style-type: none"> <li>■ GPRS 1 link</li> <li>■ EGPRS 1 link</li> </ul>
WCDMA II	<ul style="list-style-type: none"> <li>■ RMC 12.2Kbps link</li> </ul>	<ul style="list-style-type: none"> <li>■ RMC 12.2Kbps link</li> </ul>
WCDMA Band V	<ul style="list-style-type: none"> <li>■ RMC 12.2Kbps link</li> </ul>	<ul style="list-style-type: none"> <li>■ RMC 12.2Kbps link</li> </ul>

Note: The maximum power levels are GPRS multi-slot class 12 mode for GSM link, EGPRS multi-slot class 12 mode for 8PSK link, RMC12.2Kbps mode for WCDMA Band V/II. only these modes were used for all tests.

### 4.2 Configuration of Tested System

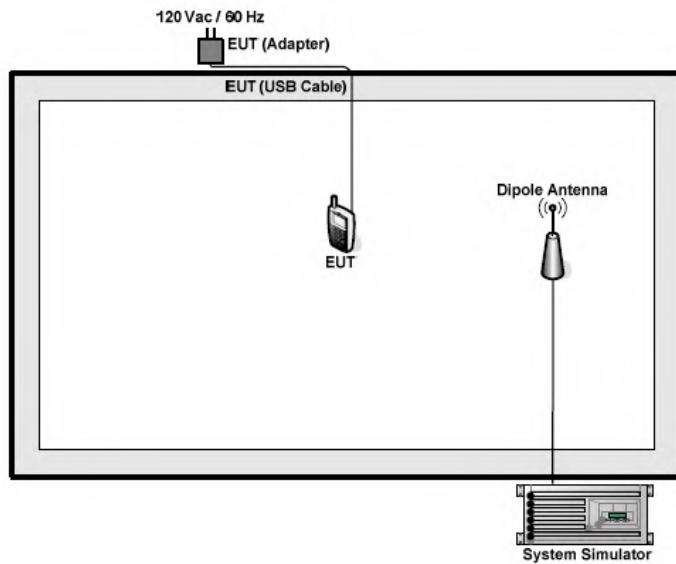

### 4.3 Conducted AV Output Power

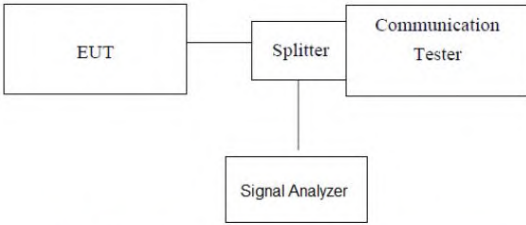
Test Requirement:	FCC part22.913(a), FCC part24.232(b), FCC part27.50(d)(4), RSS-132 (5.4), RSS-133 (4.1), RSS-139(4.1)
Test Method:	FCC part2.1046, ANSI/TIA-603-E, ANSI C63.26 clause 5.2.4 FCC KDB971168 D01 v03r01 Section 5.2.
Limit:	GSM850, WCDMA Band V: 7W(ERP) PCS1900, WCDMA Band II: 2W(EIRP)
Test setup:	 <pre> graph LR     EUT[EUT] --- Splitter[Splitter]     Splitter --- CT[Communication Tester]     Splitter --- SA[Signal Analyzer]   </pre> <p><i>Note: Measurement setup for testing on Antenna connector</i></p>
Test Procedure:	<ol style="list-style-type: none"> <li>1. The transmitter output port was connected to base station.</li> <li>2. The RF output of EUT was connected to the Signal Analyzer by RF cable and attenuator, the path loss was compensated to the results for each measurement.</li> <li>3. Set EUT at maximum power through base station.</li> <li>4. Select lowest, middle, and highest channels for each band and different modulation.</li> <li>5. Measure the maximum frame average power.</li> </ol>
Test Instruments:	Refer to section 3 for details
Test mode:	Refer to section 4.1 for details
Test results:	Pass

## Measurement Data

Conducted Burst Power (dBm)						
Band	GSM850			PCS1900		
Channel	128	190	251	512	661	810
Frequency	824.20	836.60	848.80	1850.20	1880.00	1909.80
GPRS (GMSK, 1 TX slot)	30.22	30.29	30.35	27.69	27.76	<b>27.82</b>
GPRS (GMSK, 2 TX slot)	30.51	30.60	<b>30.65</b>	27.35	27.44	27.49
GPRS (GMSK, 3 TX slot)	30.16	30.24	30.29	25.55	25.63	25.68
GPRS (GMSK, 4 TX slot)	28.91	28.97	29.01	23.29	23.35	23.39
EGPRS (8PSK, 1 TX slot)	25.73	25.80	25.86	26.48	26.55	26.61
EGPRS (8PSK, 2 TX slot)	23.90	23.95	23.98	22.38	22.43	22.46
EGPRS (8PSK, 3 TX slot)	22.64	22.67	22.74	20.95	20.98	21.05
EGPRS (8PSK, 4 TX slot)	20.57	20.63	20.68	19.84	19.90	19.95

Burst Average Power (dBm)						
Band	WCDMA Band II			WCDMA Band V		
Channel	9262	9400	9538	4132	4183	4233
Frequency	1852.4	1880.0	1907.6	826.4	836.6	846.6
RMC 12.2Kbps	22.76	22.83	22.89	23.02	23.09	<b>23.15</b>
HSDPA Subtest-1	22.64	22.73	22.78	20.74	20.83	20.88
HSDPA Subtest-2	21.83	21.91	21.96	22.01	22.09	22.14
HSDPA Subtest-3	22.60	22.66	22.70	20.99	21.05	21.09
HSDPA Subtest-4	22.16	22.23	22.29	20.48	20.55	20.61
HSUPA Subtest-1	23.20	23.25	<b>23.28</b>	21.83	21.88	21.91
HSUPA Subtest-2	21.89	21.92	21.99	22.96	22.99	23.06
HSUPA Subtest-3	21.93	21.99	22.04	21.90	21.96	22.01
HSUPA Subtest-4	22.19	22.24	22.30	21.25	21.30	21.36
HSUPA Subtest-5	21.87	21.91	21.96	22.09	22.13	22.18
AMR	22.88	22.92	22.97	21.36	21.40	21.45

#### 4.4 Peak-to-Average Ratio

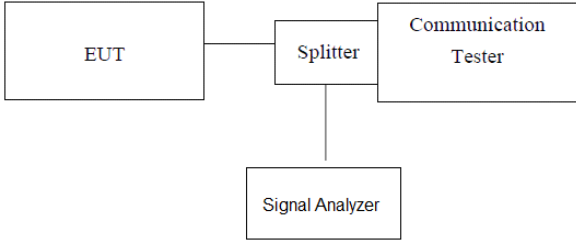
Test Requirement:	Part 22.913(d), FCC part24.232(d), FCC part27.50(d)(5), RSS-132 (5.4), RSS-133 (6.4), RSS-139(6.5)
Test Method:	FCC part2.1046, ANSI/TIA-603-E, ANSI C63.26 Clause 5.2.3.4 FCC KDB971168 D01 v03r01 Section 5.7
Limit:	13db
Test setup:	 <p><i>Note: Measurement setup for testing on Antenna connector</i></p>
Test Procedure:	<ol style="list-style-type: none"> <li>1. The transmitter output port was connected to base station.</li> <li>2. The RF output of EUT was connected to the Signal Analyzer by RF cable and attenuator, the path loss was compensated to the results for each measurement.</li> <li>3. Set EUT at maximum power through base station.</li> <li>4. Select lowest, middle, and highest channels for each band and different modulation.</li> <li>5. Measure the maximum burst average power.</li> <li>6. Record the maximum peak-to-average ratio value.</li> </ol>
Test Instruments:	Refer to section 3 for details
Test mode:	Refer to section 4.1 for details
Test results:	Pass

Measurement data

Test mode	Peak to Average Ratio (dB)			Limit (dB)	Result
	Low Ch.	Middle Ch.	High Ch.		
GSM/TM1/GSM850(GPRS)	9.66	10.82	9.25	13	PASS
GSM/TM1/GSM1900(GPRS)	9.99	9.69	9.18	13	PASS

GPRS 850  
Low Ch

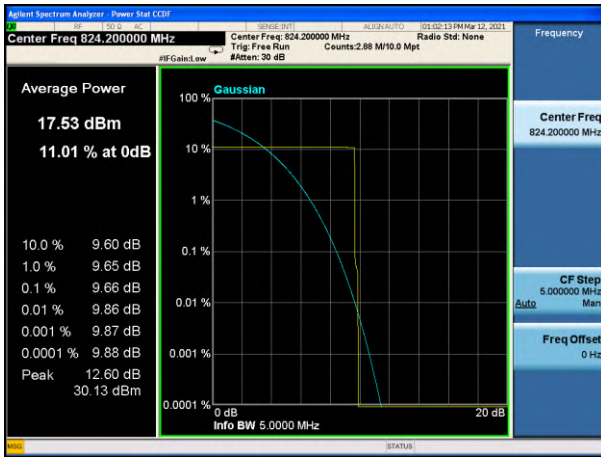

Middle Ch

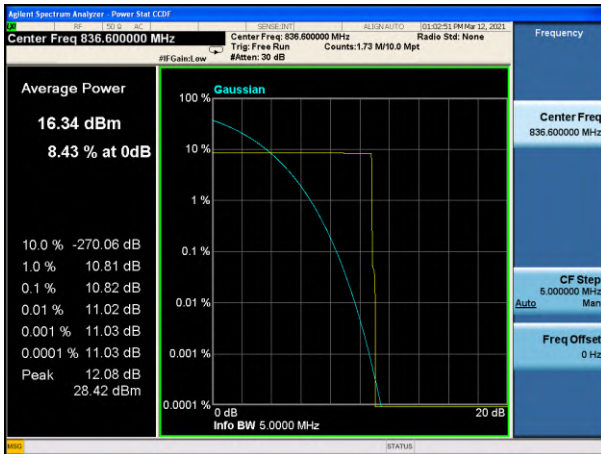

High Ch



GPRS 1900  
Low Ch

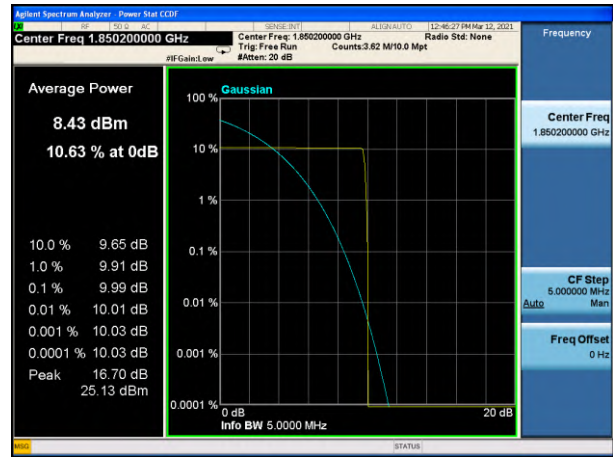

Middle Ch



High Ch

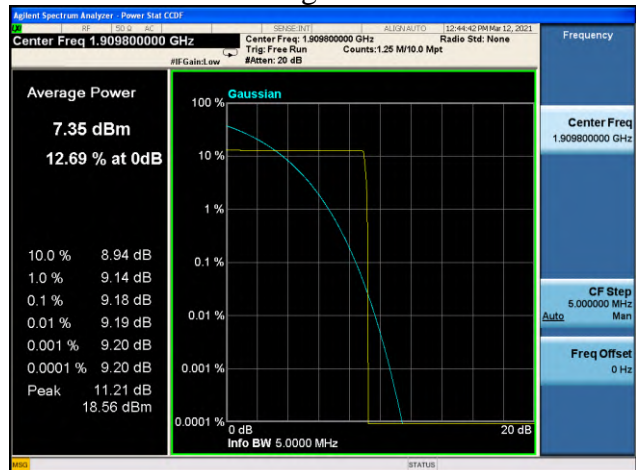

Test mode	Peak to Average Ratio (dB)			Limit (dB)	Result
	Low Ch.	Middle Ch.	High Ch.		
GSM/TM1/GSM850(EGPRS)	9.23	11.51	12.28	13	PASS
GSM/TM1/GSM1900(EGPRS)	9.46	9.29	9.07	13	PASS

EGPRS 850  
Low Ch

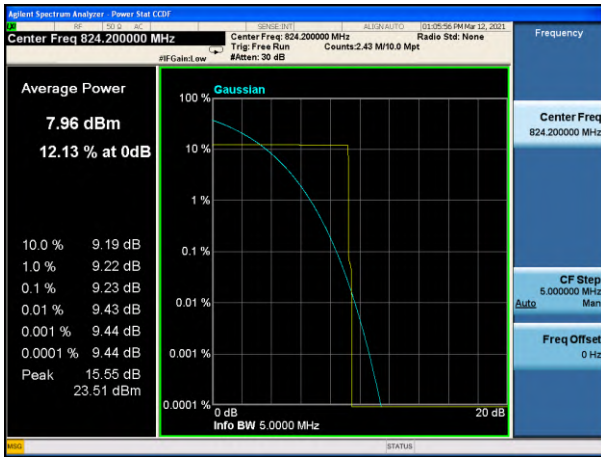

Middle Ch



High Ch



EGPRS 1900  
Low Ch

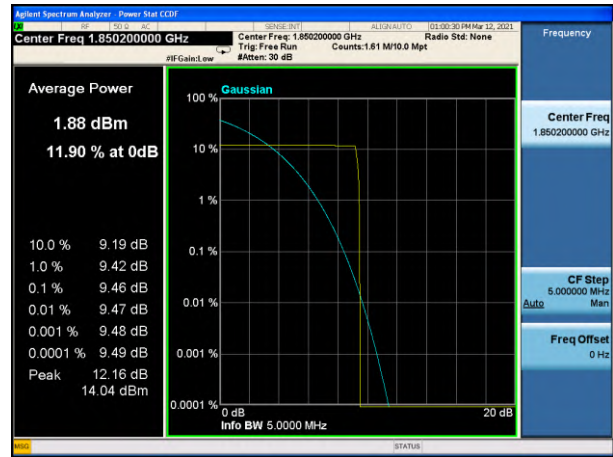

Middle Ch



High Ch





Test mode	Peak to Average Ratio ( dB )			Limit ( dB )	Result
	Low Ch.	Middle Ch.	High Ch.		
WCDMA Band II	2.97	3.09	3.02	13	PASS
WCDMA Band V	3.09	3.06	3.09		

WCDMA Band II

Low Ch

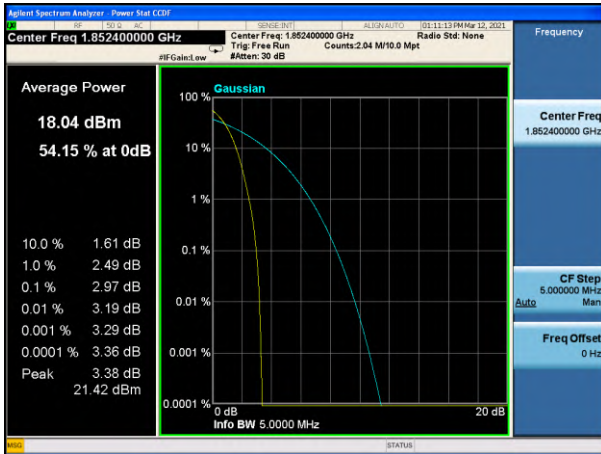

Middle Ch



High Ch

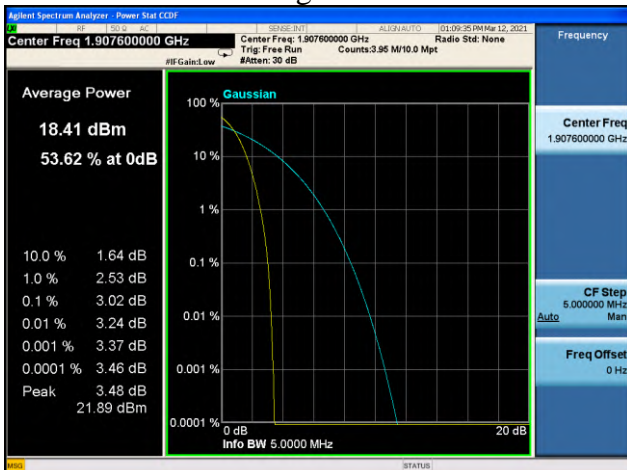

WCDMA Band V

Low Ch

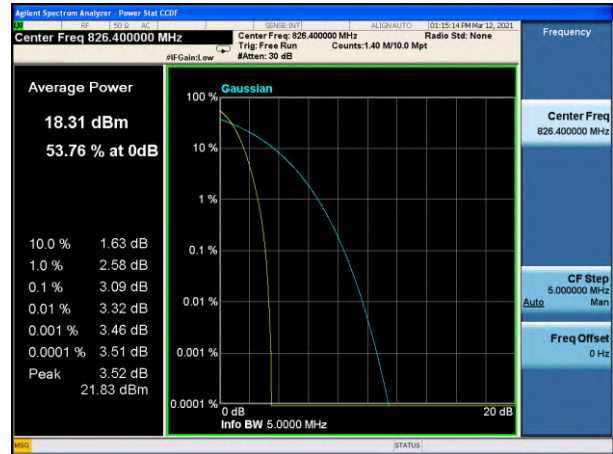

Middle Ch



High Ch

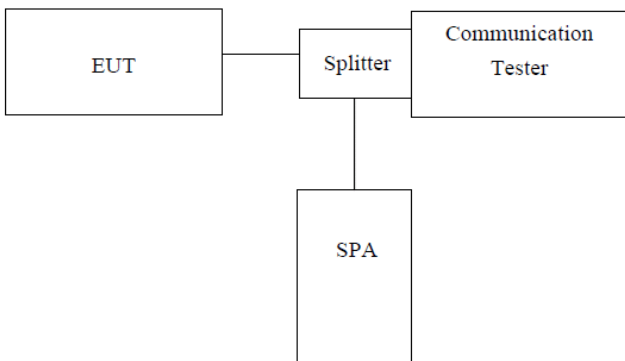

#### 4.5 Occupy Bandwidth

Test Requirement:	FCC part22.913(a), FCC part24.232(b), FCC part27.53(h), RSS-132(3.1), RSS-133(2.3), RSS-139(2.3)
Test Method:	KDB 971168 D01 v03r1 clause 4, FCC part2.1049, ANSI/TIA-603-E, ANSI C63.26 clause 5.4, RSS-Gen Section 6.7.
Test setup:	 <pre> graph LR     EUT[EUT] --- Splitter[Splitter]     Splitter --- CT[Communication Tester]     Splitter --- SPA[SPA]   </pre> <p><i>Note: Measurement setup for testing on Antenna connector</i></p>
Test Procedure:	<ol style="list-style-type: none"> <li>1. The EUT's output RF connector was connected with a short cable to the spectrum analyzer</li> <li>2. RBW was set to about 1% of emission BW, VBW= 3 times RBW.</li> <li>3. -26dBc display line was placed on the screen (or 99% bandwidth), the occupied bandwidth is the delta frequency between the two points where the display line intersects the signal trace.</li> </ol>
Test Instruments:	Refer to section 3 for details
Test mode:	Refer to section 4.1 for details
Test results:	Pass

## Measurement Data

EUT Mode	Channel	Frequency (MHz)	99% Occupy bandwidth (KHz)	-26dB bandwidth (KHz)
GSM 850 (GPRS 1 link)	128	824.20	243.51	320.6
	190	836.60	247.28	312.7
	251	848.80	244.26	316.0
GSM 850 (EGPRS 1 link)	128	824.20	241.54	307.2
	190	836.60	244.10	311.9
	251	848.80	239.8	309.0
PCS 1900 (GPRS 1 link)	512	1850.20	246.74	317.9
	661	1880.00	243.36	309.2
	810	1909.80	248.20	316.8
PCS 1900 (EGPRS 1 link)	512	1850.20	239.37	303.2
	661	1880.00	245.47	310.8
	810	1909.80	237.78	314.2
WCDMA Band V (RMC 12.2Kbps link)	4132	826.40	4106.3	4715
	4183	836.60	4122.9	4725
	4233	846.60	4115.5	4709
WCDMA Band II (RMC 12.2Kbps link)	9262	1852.4	4120.0	4725
	9400	1880.0	4128.9	4734
	9538	1907.6	4121.9	4729

Test plot as follows:

GSM 850 (GPRS 1 link)	GSM 850 (EGPRS 1 link)
-----------------------	------------------------



Lowest channel

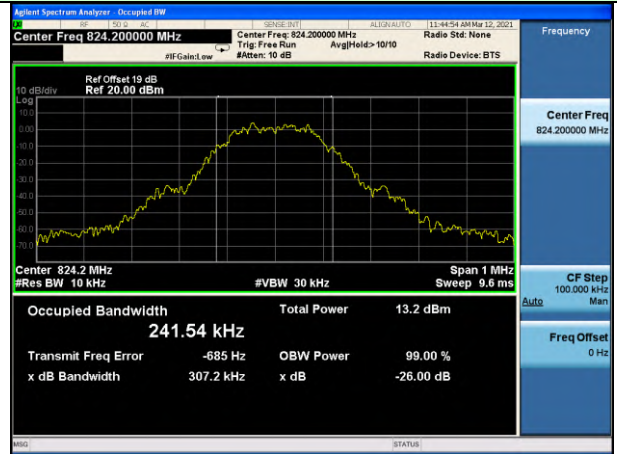

Lowest channel

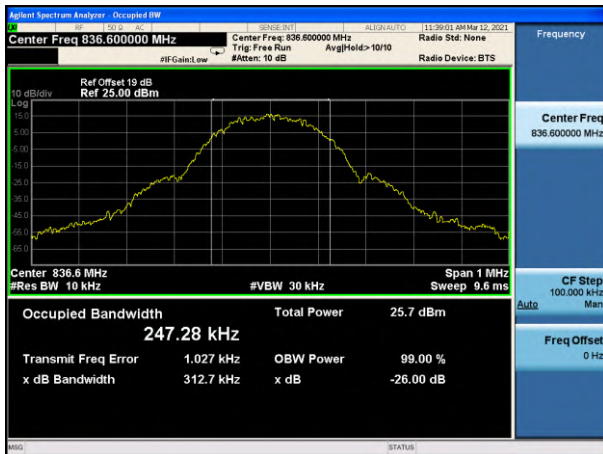

Middle channel

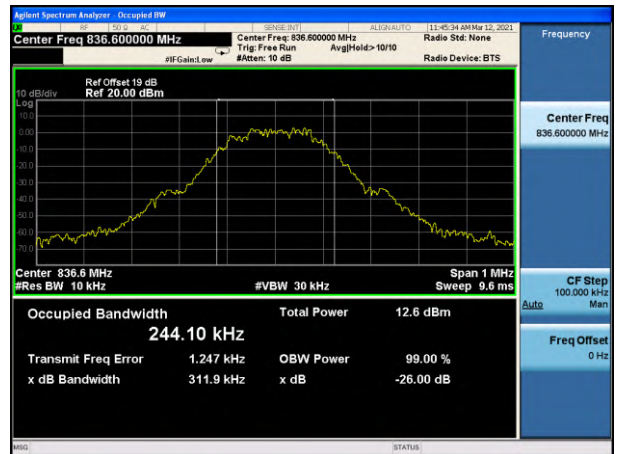

Middle channel

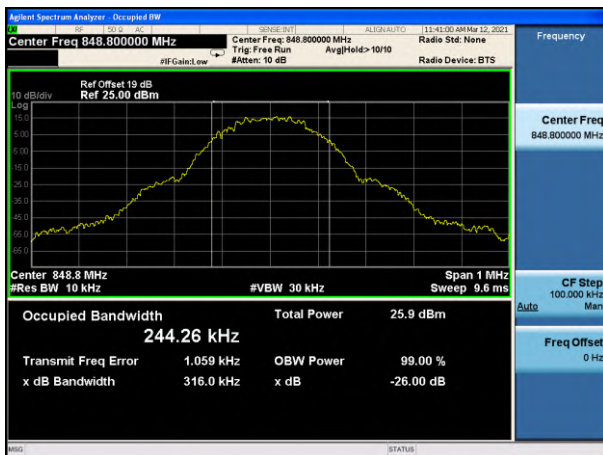

Highest channel

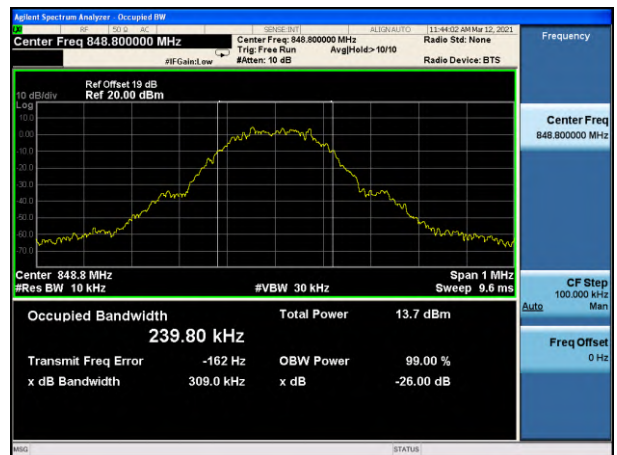

Highest channel

PCS 1900 (GPRS 1 link)	PCS 1900 (EGPRS 1 link)
------------------------	-------------------------

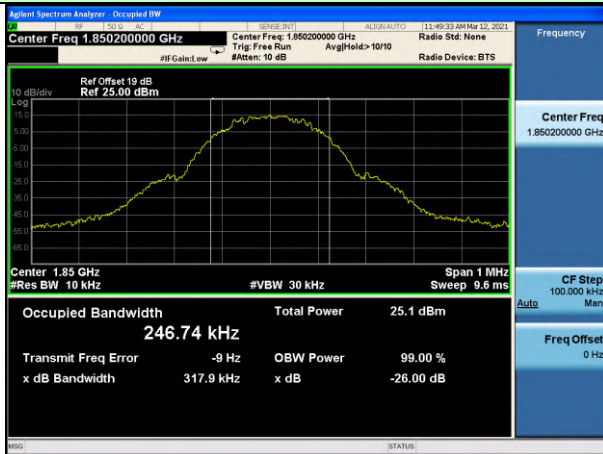

Lowest channel

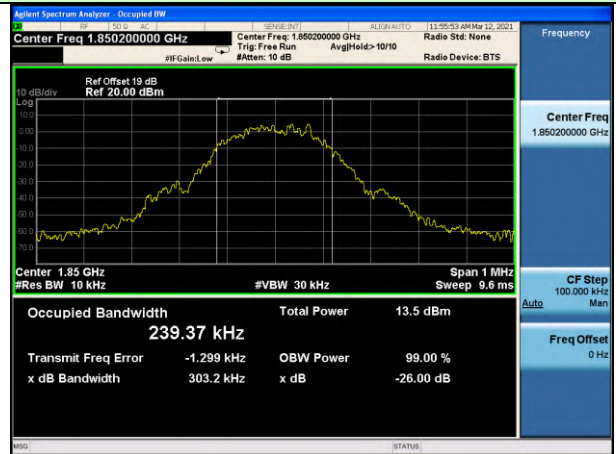

Lowest channel

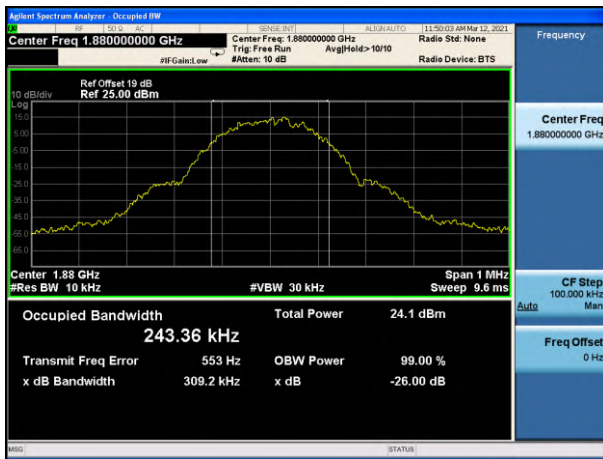

Middle channel

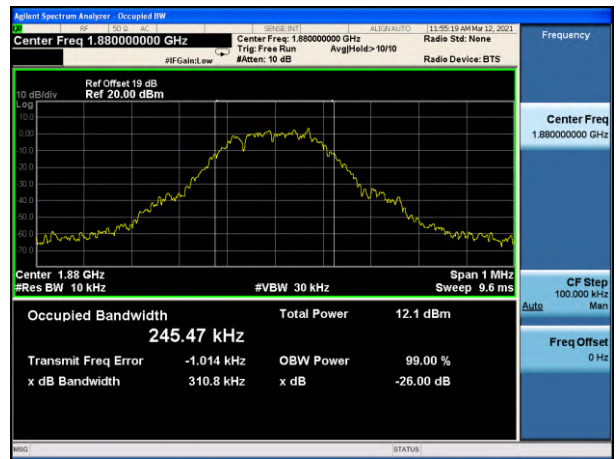

Middle channel

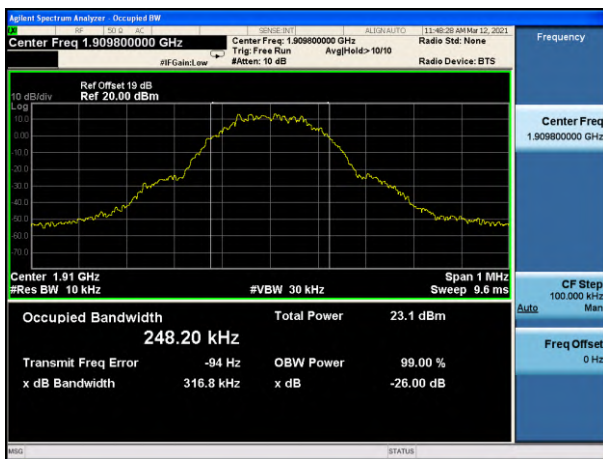

Highest channel

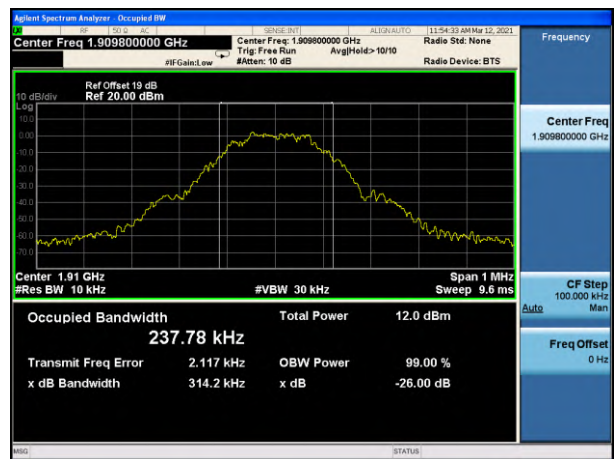

Highest channel



WCDMA Band V (RMC 12.2Kbps link)	WCDMA Band II (RMC 12.2Kbps link)
----------------------------------	-----------------------------------

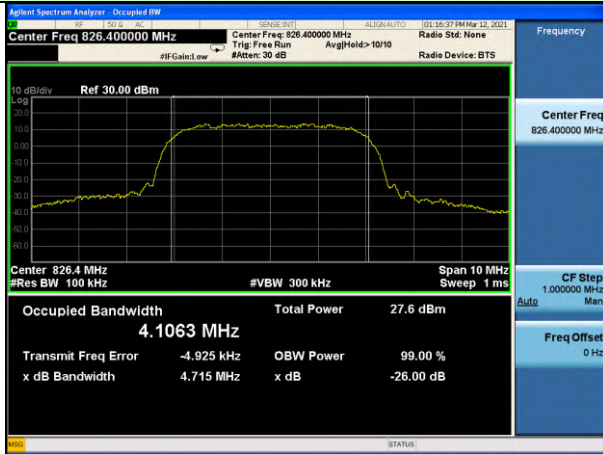

Lowest channel

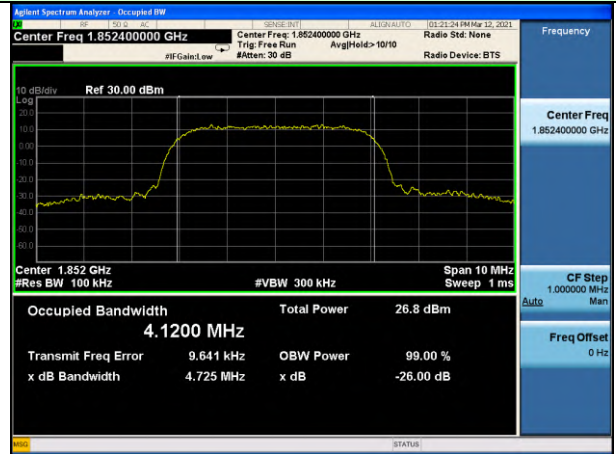

Lowest channel

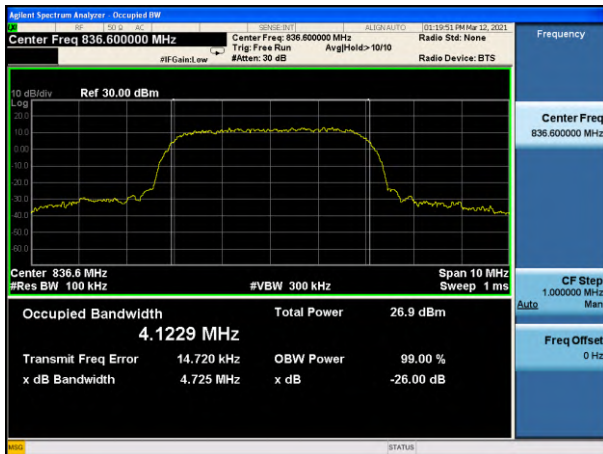

Middle channel



Middle channel

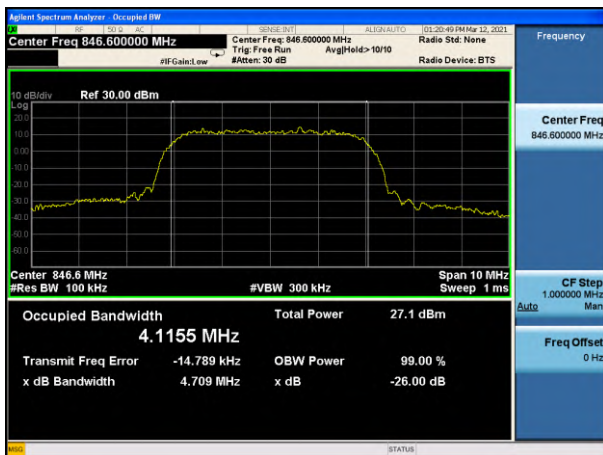

Highest channel



Highest channel

#### 4.6 MODULATION CHARACTERISTIC

According to FCC § 2.1047(d), Part 22H, 24E & 27C, there is no specific requirement for digital modulation, therefore modulation characteristic is not presented.

According to RSS-132, RSS-133, RSS-199, the equipment certified under these standards shall employ digital modulation, but there is no specific requirement for digital modulation, therefore modulation characteristic is not presented.

#### 4.7 Out of band emission at antenna terminals

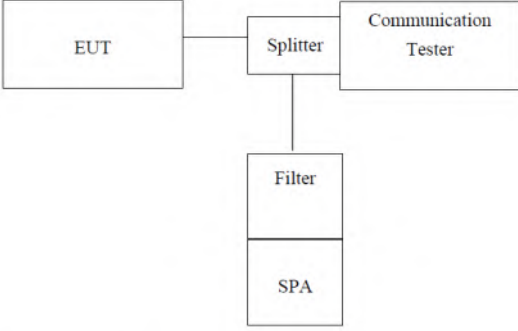
Test Requirement:	FCC part22.917(a), FCC part24.238(a), FCC part27.53(h) RSS-132(5.5), RSS-133(6.5), RSS-139(6.5)
Test Method:	KDB 971168 D01 v03r1 clause 6, FCC part2.1051, ANSI/TIA-603-E, ANSI C63.26 clause 5.7
Limit:	-13dBm
Test setup:	 <p><i>Note: Measurement setup for testing on Antenna connector</i></p>
Test Procedure:	<ol style="list-style-type: none"> <li>1 The RF output of the transceiver was connected to a spectrum analyzer through appropriate attenuation.</li> <li>2 The resolution bandwidth of the spectrum analyzer was set at 1MHz, sufficient scans were taken to show the out of band Emissions if any up to 10th harmonic.</li> <li>3 For the out of band: Set the RBW= 1MHz, VBW = 3MHz, Start=30MHz, Stop= 10th harmonic.</li> <li>4 Band Edge Requirements: In the 1 MHz bands immediately outside and adjacent to the frequency block, a resolution bandwidth of at least 1 percent of the emission bandwidth of the fundamental emission of the transmitter may be employed to measure the out of band Emissions.</li> </ol>
Test Instruments:	Refer to section 3 for details
Test mode:	Refer to section 4.1 for details
Test results:	Pass

Test plot as follows:

Test Mode: Traffic mode GSM 850 (GPRS 1 link)

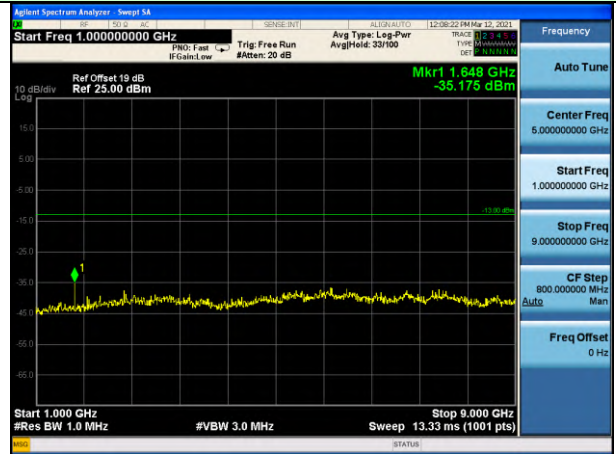
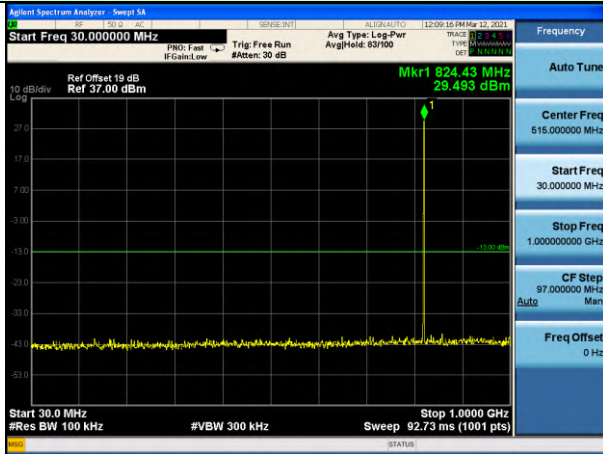

Lowest channel

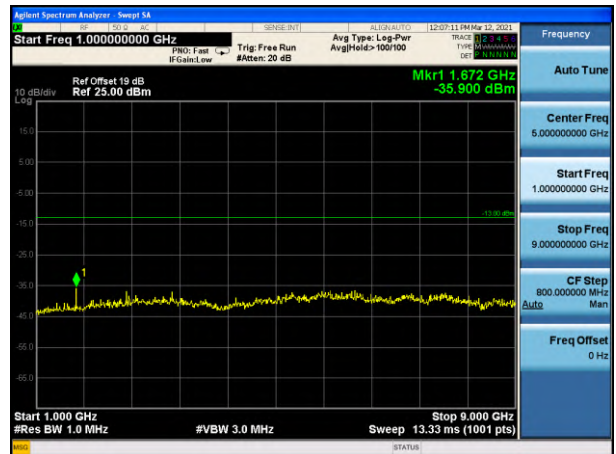
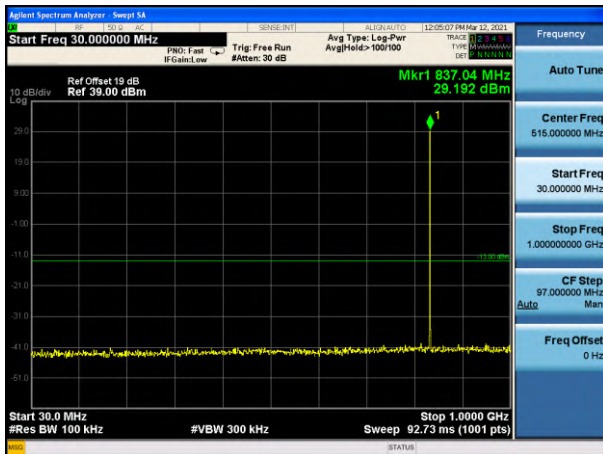

Middle channel

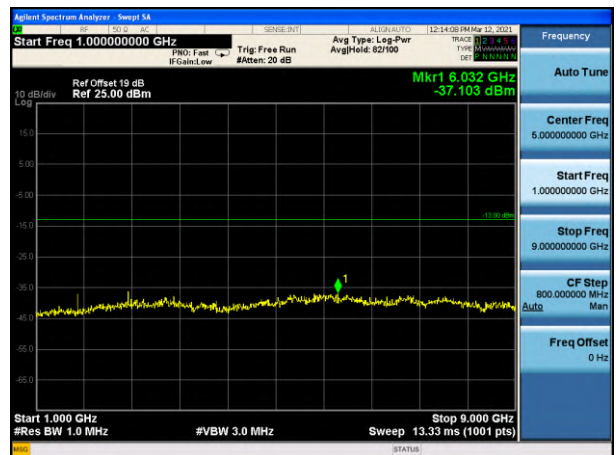
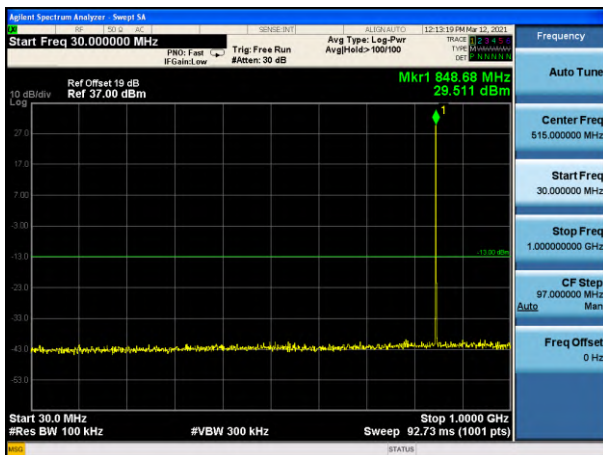

Highest channel



Test Mode: Traffic mode

GSM 850 (EGPRS 1 link)

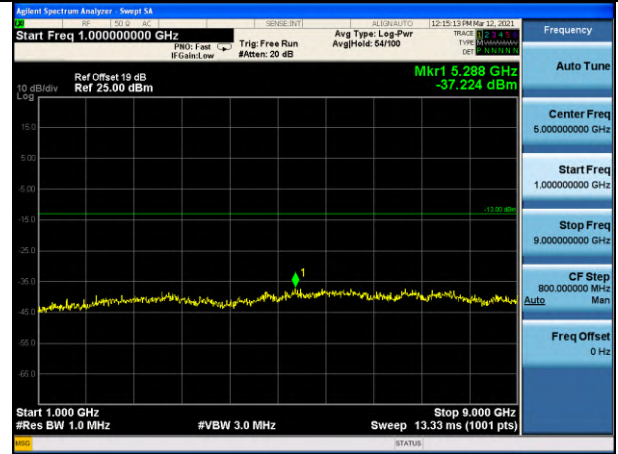
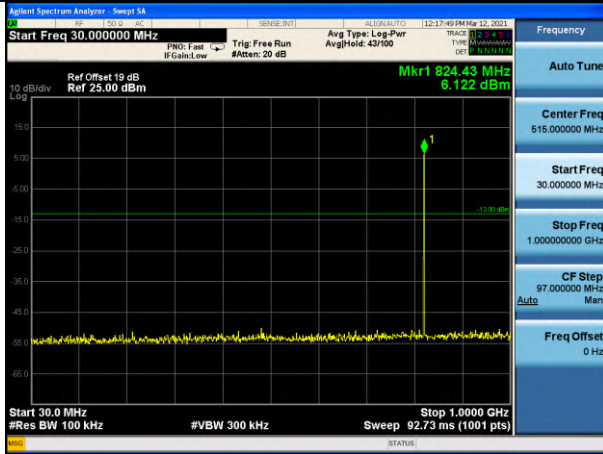

Lowest channel

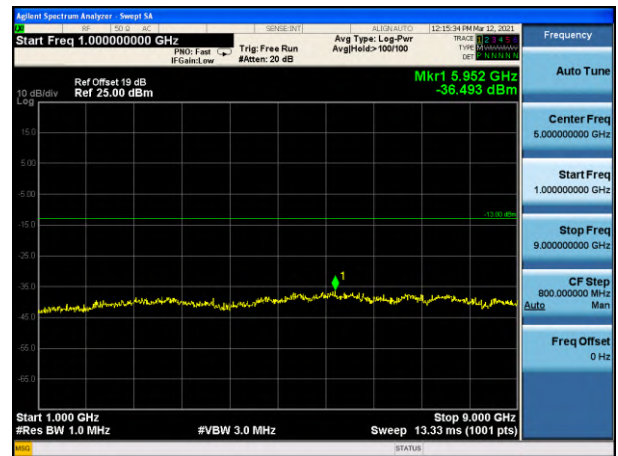
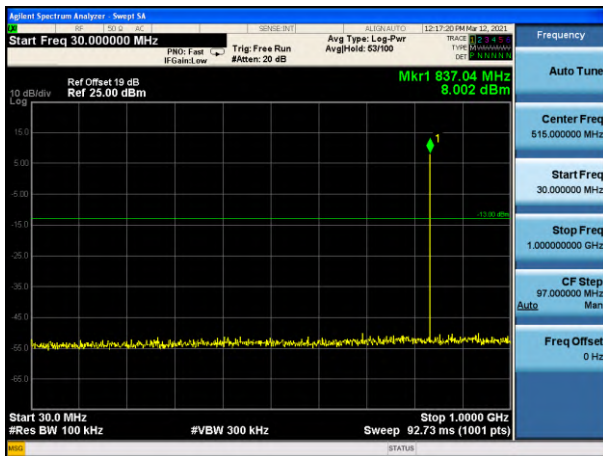

Middle channel

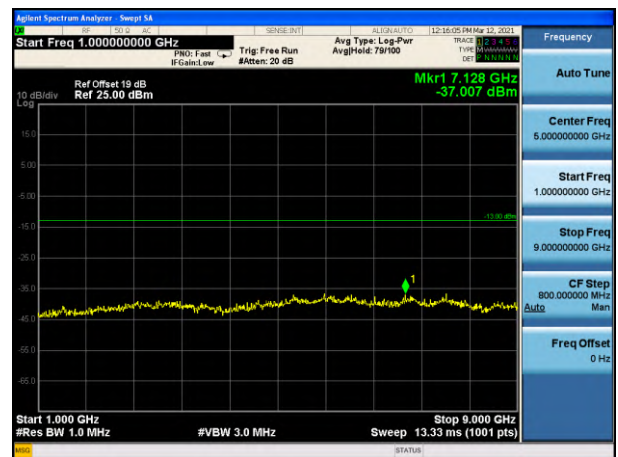
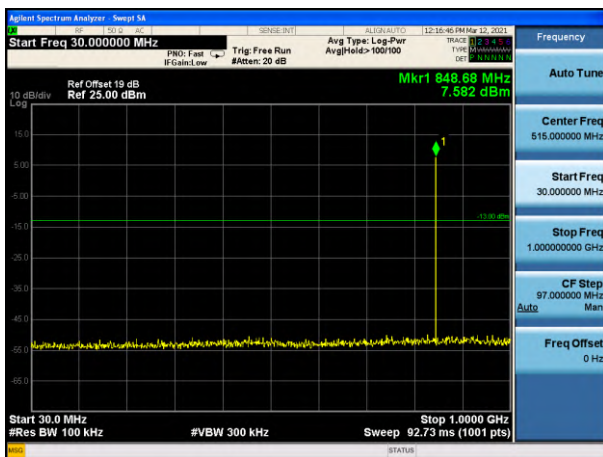

Highest channel

Test Mode: Traffic mode

PCS1900 (GPRS 1 link)

PCS1900 (EGPRS 1 link)



Lowest channel



Middle channel

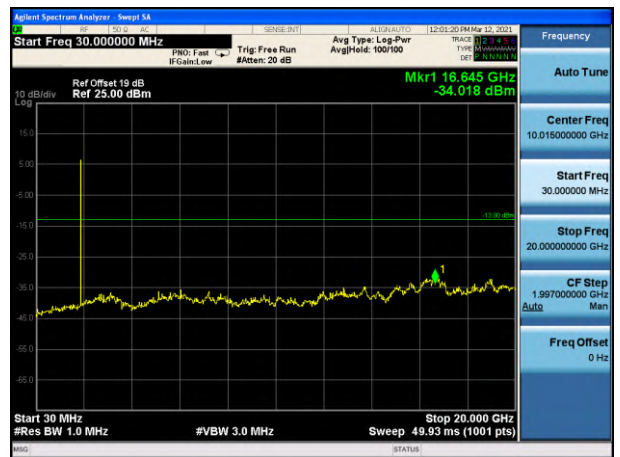

Highest channel

Test Mode: Traffic mode

WCDMA Band V (RMC 12.2Kbps link)

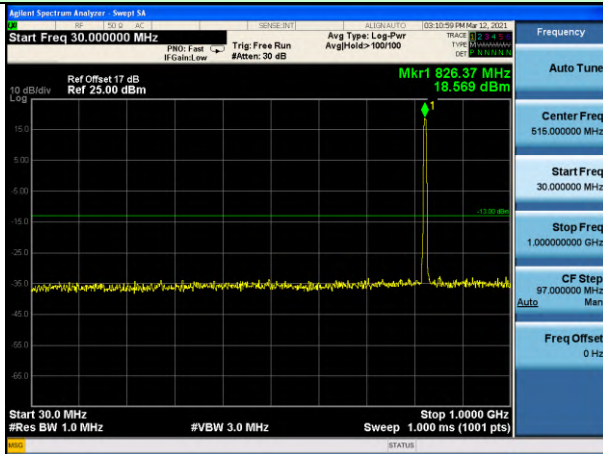

Lowest channel

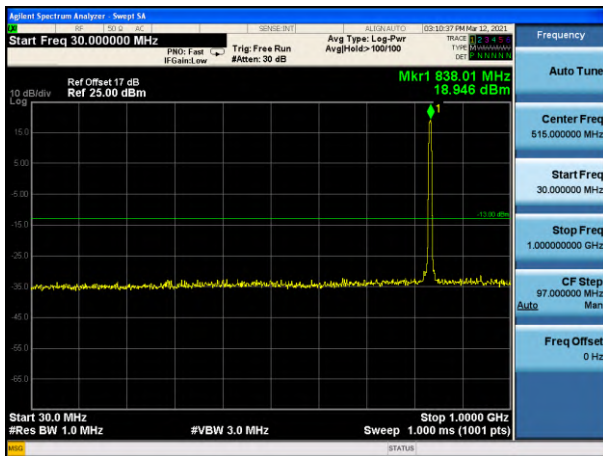

Middle channel

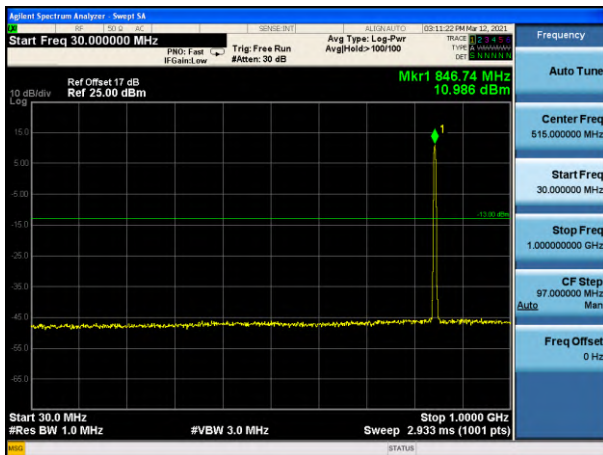

Highest channel



Test Mode: Traffic mode

WCDMA Band II (RMC 12.2Kbps link)

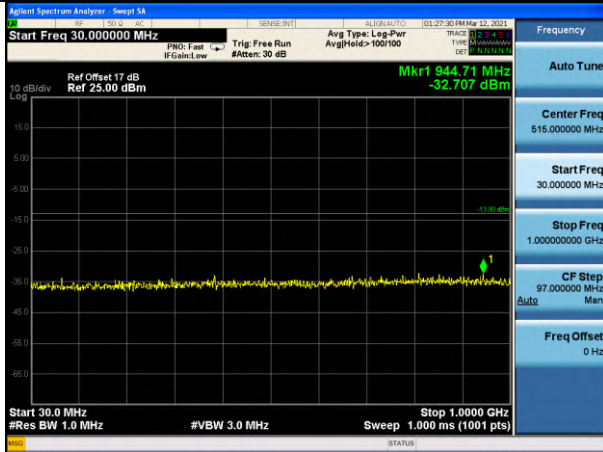

Lowest channel

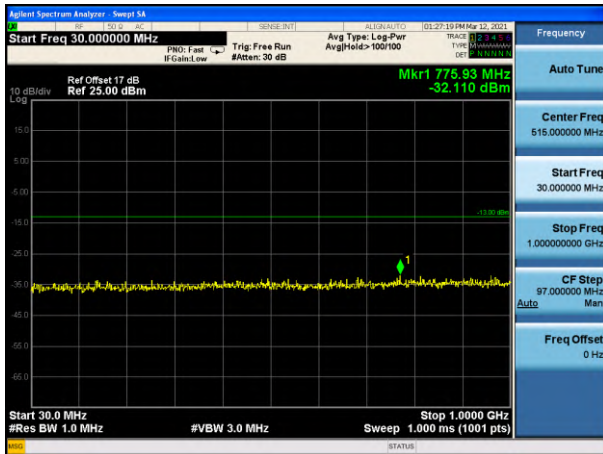

Middle channel

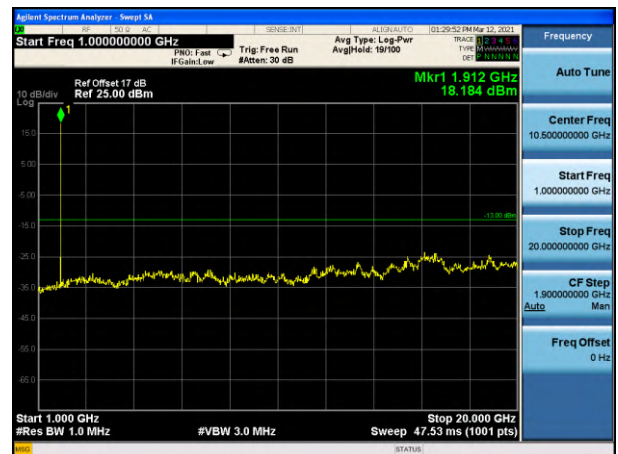
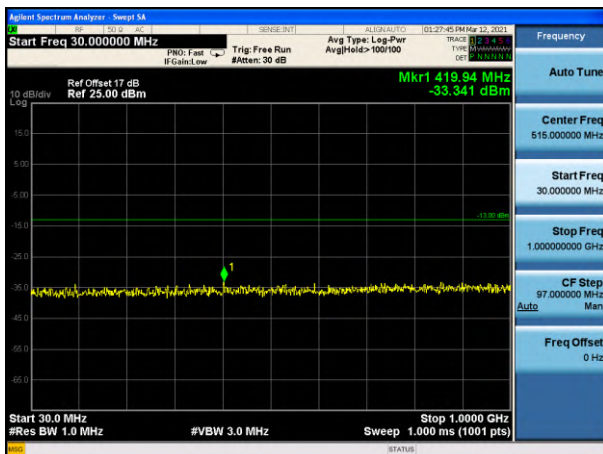

Highest channel

Band Edge:

Test Mode: Traffic mode GSM850 (GPRS 1 link)

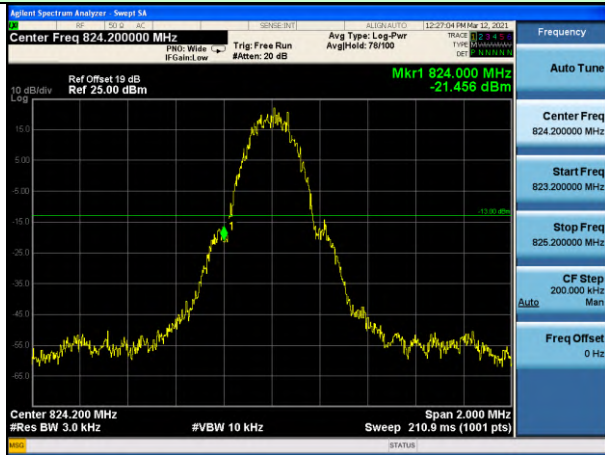

Lowest channel

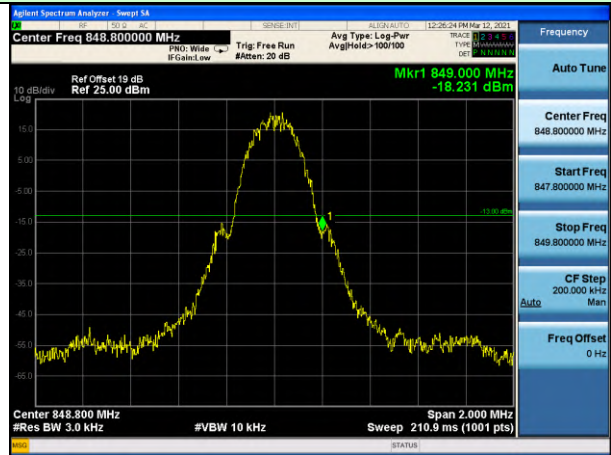

Highest channel

Test Mode: Traffic mode GSM850 (EGPRS 1 link)

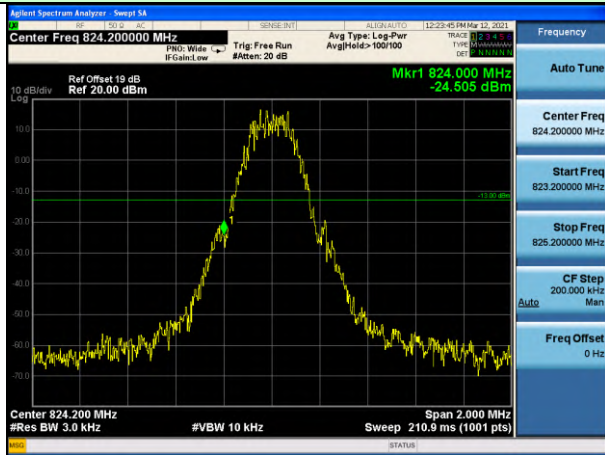

Lowest channel

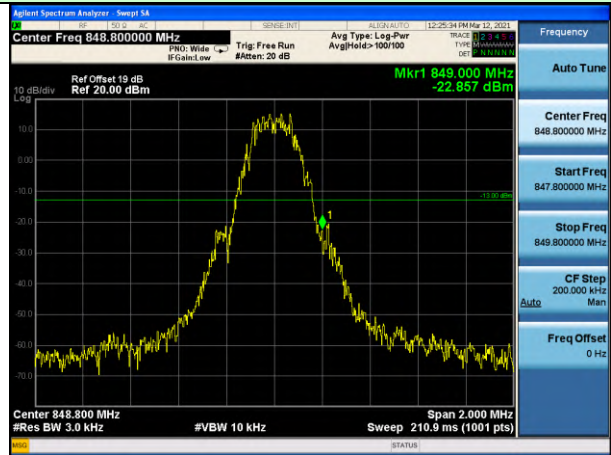

Highest channel

Test Mode: Traffic mode PCS1900 (GPRS 1 link)

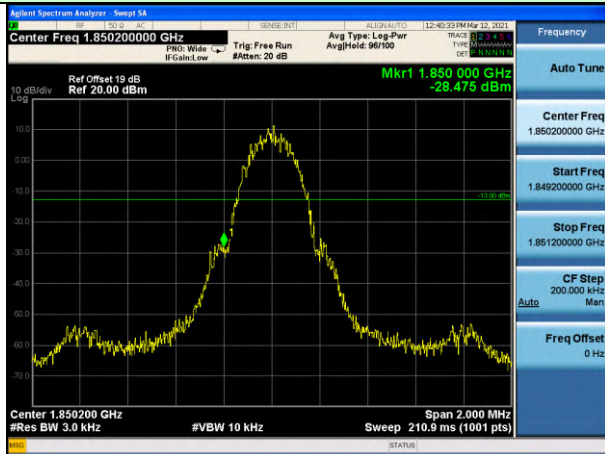

Lowest channel

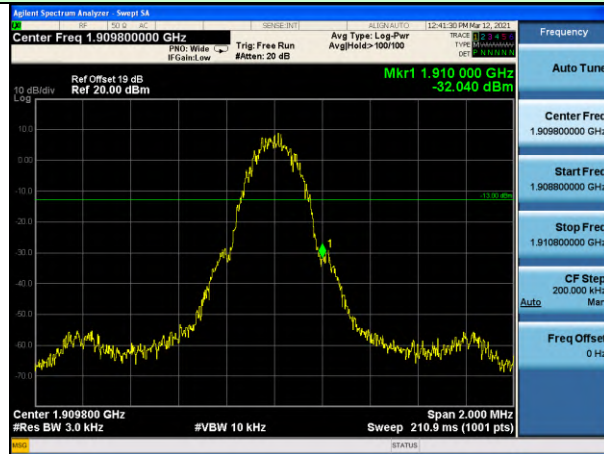

Highest channel

Test Mode: Traffic mode PCS1900 (EGPRS 1 link)

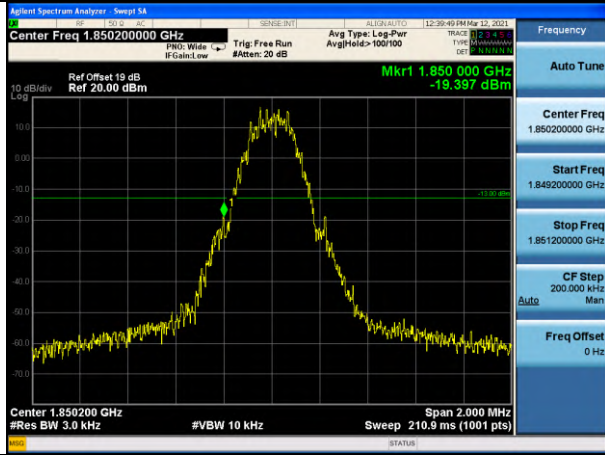

Lowest channel

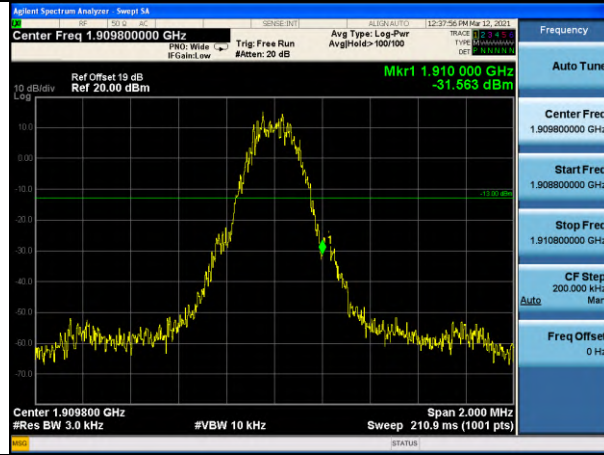

Highest channel



Test Mode: Traffic mode WCDMA Band V (RMC 12.2Kbps link)

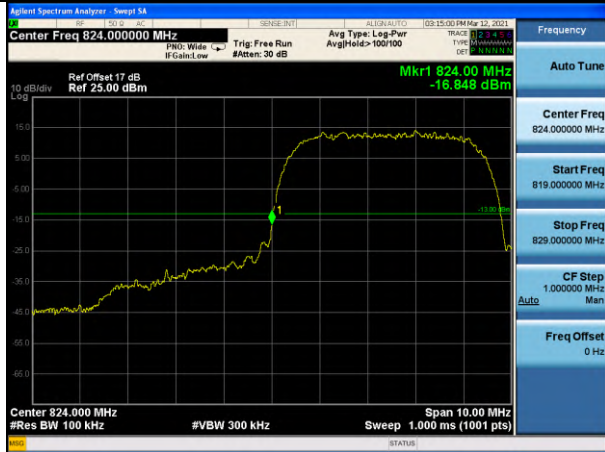

Lowest channel



Highest channel

Test Mode: Traffic mode WCDMA Band II (RMC 12.2Kbps link)

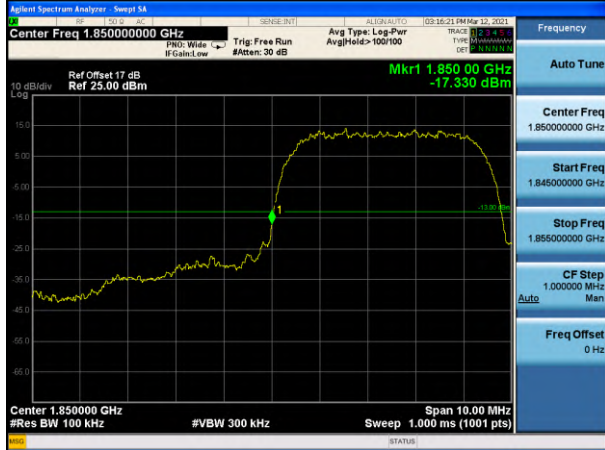

Lowest channel



Highest channel

**4.8 ERP, EIRP Measurement**

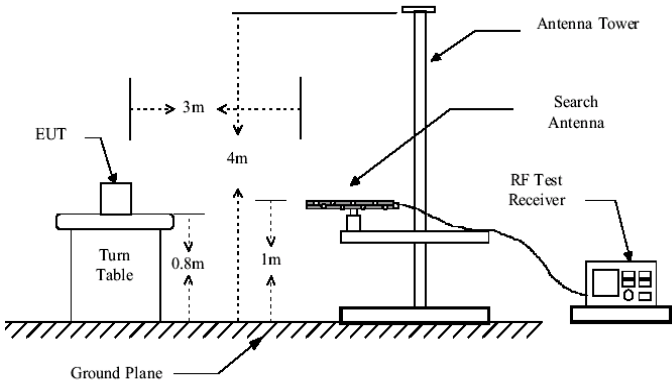
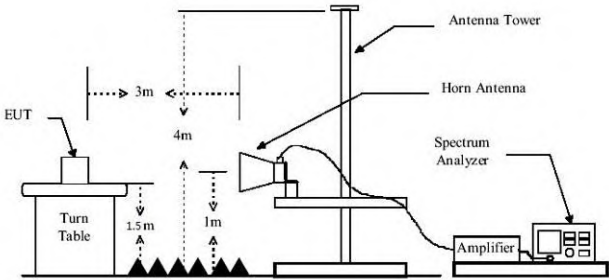
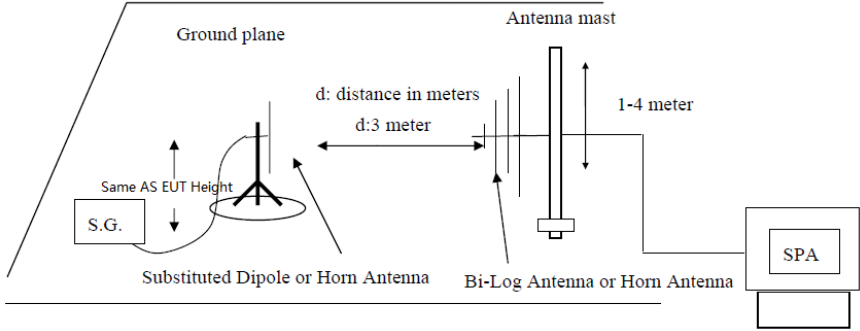
<p>Test Requirement:</p>	<p>FCC part22.913(a), FCC part24.232(b), FCC part27.50(d)(4), RSS-132 (5.4), RSS-133 (4.1), RSS-139(4.1)</p>
<p>Test Method:</p>	<p>KDB 971168 D01 v03r1 clause 5.8, FCC part2.1051, ANSI/TIA-603-E, ANSI C63.26 clause 5.7</p>
<p>Limit:</p>	<p>GSM850, WCDMA Band V: 7W PCS1900, WCDMA Band II: 2W</p>
<p>Test setup:</p>	<p>Below 1GHz</p>  <p>Above 1GHz</p>  <p>Substituted method:</p> 



Test Procedure:	<ol style="list-style-type: none"> <li>1. The EUT was placed on an non-conductive turntable using a non-conductive support. The radiated emission at the fundamental frequency was measured at 3 m with a test antenna and EMI spectrum analyzer.</li> <li>2. During the measurement, the EUT was communication with the station. The highest emission was recorded with the rotation of the turntable and the lowering of the test antenna from 4m to 1m. The reading was recorded and the field strength (E in dBuV/m) was calculated.</li> <li>3. ERP in frequency band 824.2 –848.80.8MHz were measured using a substitution method. The EUT was replaced by dipole antenna connected, the S.G. output was recorded and ERP was calculated asfollows:  <math display="block">\text{ERP} = \text{S.G. output (dBm)} + \text{Antenna Gain (dBd)} - \text{Cable Loss (dB)}</math> </li> <li>4. EIRP in frequency band 1712.6-1752.4, 1850.2 –1909.8MHz were measured using a substitution method. The EUT was replaced by or horn antenna connected, the S.G. output was recorded and EIRP was calculated as follows:  <math display="block">\text{EIRP} = \text{S.G. output (dBm)} + \text{Antenna Gain (dBi)} - \text{Cable Loss (dB)}</math> </li> </ol>
Test Instruments:	Refer to section 3 for details
Test mode:	Refer to section 4.1 for details
Test results:	Pass

## Measurement Data

GPRS850	Frequency (MHz)	PMea (dBm)	Pcl(dB)+PA g(dB)	Ga Antenna Gain (dBi)	Correction (dB)	ERP (dBm)	Limit (dBm)	Positive	Margin (dB)
	824.20	-4.92	-33.60	-0.79	2.15	25.74	38.45	H	-12.71
	836.60	-5.03	-33.50	-0.74	2.15	25.58	38.45	H	-12.87
	848.80	-4.95	-33.50	-0.73	2.15	25.67	38.45	H	-12.78
EGPRS850	Frequency (MHz)	PMea (dBm)	Pcl(dB)+P Ag(dB)	Ga Antenna Gain(dBi)	Correction (dB)	ERP (dBm)	Limit (dBm)	Polarity	Margin (dB)
	824.20	-8.55	-33.60	-0.79	2.15	22.11	38.45	H	-16.34
	836.60	-9.43	-33.50	-0.74	2.15	21.18	38.45	H	-17.27
	848.80	-8.92	-33.50	-0.73	2.15	21.70	38.45	H	-16.75

GPRS1900	Frequency (MHz)	PMea (dBm)	Pcl(dB)+PA g(dB)	Ga Antenna Gain (dBi)	Correction (dB)	EIRP (dBm)	Limit (dBm)	Polarity	Margin (dB)
	1850.20	-13.40	-29.40	8.10	/	24.10	33.00	H	-8.90
	1880.00	-14.19	-29.30	8.10	/	23.21	33.00	H	-9.79
	1909.80	-11.45	-29.30	8.10	/	25.95	33.00	H	-7.05
EGPRS1900	Frequency (MHz)	PMea (dBm)	Pcl(dB)+P Ag(dB)	Ga Antenna Gain(dBi)	Correction (dB)	EIRP (dBm)	Limit (dBm)	Polarity	Margin (dB)
	1850.20	-18.45	-29.40	8.10	/	19.05	33.00	H	-13.95
	1880.00	-18.09	-29.30	8.10	/	19.31	33.00	H	-13.69
	1909.80	-17.10	-29.30	8.10	/	20.30	33.00	H	-12.70

WCDMA 850	Frequency (MHz)	PMea (dBm)	Pcl(dB)+PA g(dB)	Ga Antenna Gain (dBi)	Correction (dB)	ERP (dBm)	Limit (dBm)	Polarity	Margin (dB)
	826.40	-10.74	-33.60	-0.84	2.15	19.87	38.45	H	-18.59
	836.60	-11.17	-33.50	-0.74	2.15	19.45	38.45	H	-19.01
	846.60	-11.67	-33.50	-0.73	2.15	18.95	38.45	H	-19.50
WCDMA 1900	Frequency (MHz)	PMea (dBm)	Pcl(dB)+P Ag(dB)	Ga Antenna Gain(dBi)	Correction (dB)	ERP (dBm)	Limit (dBm)	Polarity	Margin (dB)
	1852.40	-15.84	-29.30	8.10	/	21.56	33.00	H	-11.44
	1880.00	-14.91	-29.40	8.10	/	22.59	33.00	H	-10.41
	1907.60	-14.94	-29.30	8.10	/	22.46	33.00	H	-10.54

Remark1: ERP=PMea-Pcl-PAg+Ga Antenna Gain-Correction.

Remark2:EIRP=PMea-Pcl-PAg+Ga Antenna Gain.

### 4.9 Field strength of spurious radiation measurement

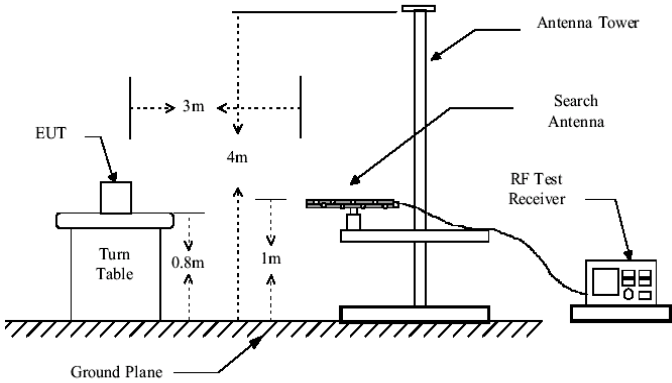
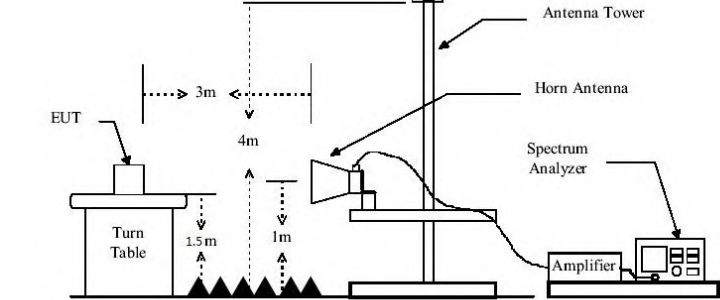
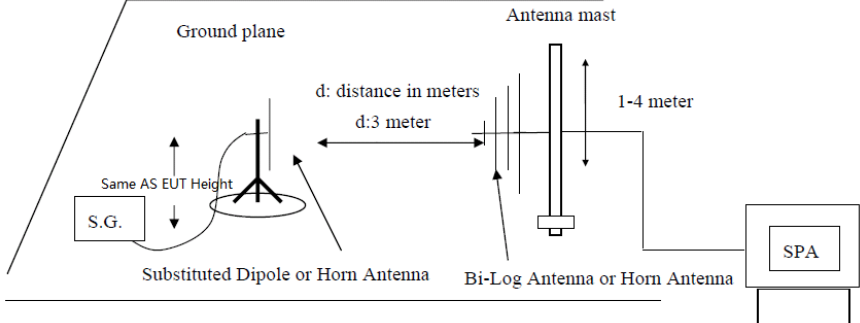
<p>Test Requirement:</p>	<p>FCC part22.917(a), FCC part24.238(a), FCC part27.53(h)                  RSS-132(5.5), RSS-133(6.5), RSS-139(6.5)</p>
<p>Test Method:</p>	<p>KDB 971168 D01 v03r1 clause 7, FCC part2.1051, ANSI/TIA-603-E, ANSI C63.26 clause 5.5</p>
<p>Limit:</p>	<p>-13dBm</p>
<p>Test setup:</p>	<p>Below 1GHz</p>  <p>Above 1GHz</p>  <p>Substituted method:</p> 

Test Procedure:	<ol style="list-style-type: none"> <li>1. The EUT was placed on a non-conductive turntable using a non-conductive support. The radiated emission at the fundamental frequency was measured at 3 m with a test antenna and EMI spectrum analyzer.</li> <li>2. During the tests, the antenna height and the EUT azimuth were varied in order to identify the maximum level of emissions from the EUT. This maximization process was repeated with the EUT positioned in each of its three orthogonal orientations.</li> <li>3. The frequency range up to tenth harmonic was investigated for each of three fundamental frequency (low, middle and high channels). Once spurious emission was identified, the power of the emission was determined using the substitution method.</li> <li>4. The spurious emissions attenuation was calculated as the difference between radiated power at the fundamental frequency and the spurious emissions frequency.  <math display="block">\text{ERP / EIRP} = \text{S.G. output (dBm)} + \text{Antenna Gain(dB/dBi)} - \text{Cable Loss (dB)}</math> </li> </ol>
Test Instruments:	Refer to section 3 for details
Test mode:	Refer to section 4.1 for details
Test results:	Pass

## Measurement Data

Test mode:	GSM850(GPRS)		Test channel:	Lowest
Frequency (MHz)	Spurious Emission		Limit (dBm)	Result
	Polarization	Level (dBm)		
1648.40	Vertical	-46.08	-13.00	Pass
2472.60	V	-46.17		
3296.80	V	-46.31		
4121.00	V	-47.05		
4945.20	V	-46.15		
1648.40	Horizontal	-42.38	-13.00	Pass
2472.60	H	-42.31		
3296.80	H	-41.05		
4121.00	H	-38.67		
4945.20	H	-38.20		
Test mode:	GSM850(GPRS)		Test channel:	Middle
Frequency (MHz)	Spurious Emission		Limit (dBm)	Result
	Polarization	Level (dBm)		
1673.20	Vertical	-46.51	-13.00	Pass
2509.80	V	-47.15		
3346.40	V	-46.85		
4183.00	V	-46.04		
5019.60	V	-45.95		
1673.20	Horizontal	-41.84	-13.00	Pass
2509.80	H	-41.47		
3346.40	H	-41.00		
4183.00	H	-39.44		
5019.60	H	-38.33		
Test mode:	GSM850(GPRS)		Test channel:	Highest
Frequency (MHz)	Spurious Emission		Limit (dBm)	Result
	Polarization	Level (dBm)		
1697.60	Vertical	-45.96	-13.00	Pass
2546.40	V	-46.57		
3395.20	V	-47.21		
4244.00	V	-45.94		
5092.80	V	-45.72		
1697.60	Horizontal	-41.09	-13.00	Pass
2546.40	H	-41.39		
3395.20	H	-41.36		
4244.00	H	-39.33		
5092.80	H	-38.45		

## Remark :

1. The emission behaviour belongs to narrowband spurious emission.
2. Remark"---" means that the emission level is too low to be measured
3. The emission levels of below 1 GHz are 20dB lower than the limit and not show in test report.

<b>Test mode:</b>	<b>GSM850(EGPRS)</b>		<b>Test channel:</b>	<b>Lowest</b>
Frequency (MHz)	Spurious Emission		Limit (dBm)	Result
	Polarization	Level (dBm)		
1648.40	Vertical	-46.30	-13.00	Pass
2472.60	V	-46.59		
3296.80	V	-46.88		
4121.00	V	-46.86		
4945.20	V	-45.93		
1648.40	Horizontal	-41.60	-13.00	Pass
2472.60	H	-42.44		
3296.80	H	-41.02		
4121.00	H	-40.28		
4945.20	H	-38.80		
<b>Test mode:</b>	<b>GSM850(EGPRS)</b>		<b>Test channel:</b>	<b>Middle</b>
Frequency (MHz)	Spurious Emission		Limit (dBm)	Result
	Polarization	Level (dBm)		
1673.20	Vertical	-47.76	-13.00	Pass
2509.80	V	-47.17		
3346.40	V	-47.67		
4183.00	V	-47.45		
5019.60	V	-45.57		
1673.20	Horizontal	-41.82	-13.00	Pass
2509.80	H	-41.75		
3346.40	H	-41.58		
4183.00	H	-40.07		
5019.60	H	-38.60		
<b>Test mode:</b>	<b>GSM850(EGPRS)</b>		<b>Test channel:</b>	<b>Highest</b>
Frequency (MHz)	Spurious Emission		Limit (dBm)	Result
	Polarization	Level (dBm)		
1697.60	Vertical	-46.76	-13.00	Pass
2546.40	V	-47.22		
3395.20	V	-46.85		
4244.00	V	-46.32		
5092.80	V	-46.17		
1697.60	Horizontal	-42.95	-13.00	Pass
2546.40	H	-42.19		
3395.20	H	-41.82		
4244.00	H	-40.63		
5092.80	H	-38.89		

Remark :

1. The emission behaviour belongs to narrowband spurious emission.
2. Remark"---" means that the emission level is too low to be measured
3. The emission levels of below 1 GHz are 20dB lower than the limit and not show in test report.

<b>Test mode:</b>	<b>PCS1900(GPRS)</b>		<b>Test channel:</b>	<b>Lowest</b>
Frequency (MHz)	Spurious Emission		Limit (dBm)	Result
	Polarization	Level (dBm)		
3700.40	Vertical	-43.99	-13.00	Pass
5550.60	V	-46.90		
7400.80	V	-45.82		
9251.00	V	-44.20		
11101.20	V	-42.41		
3700.40	Horizontal	-42.21	-13.00	Pass
5550.60	H	-38.43		
7400.80	H	-38.18		
9251.00	H	-38.12		
11101.20	H	-34.92		
<b>Test mode:</b>	<b>PCS1900(GPRS)</b>		<b>Test channel:</b>	<b>Middle</b>
Frequency (MHz)	Spurious Emission		Limit (dBm)	Result
	Polarization	Level (dBm)		
3760.00	Vertical	-46.32	-13.00	Pass
5640.00	V	-45.42		
7520.00	V	-44.13		
9400.00	V	-43.40		
11280.00	V	-42.64		
3760.00	Horizontal	-41.77	-13.00	Pass
5640.00	H	-39.87		
7520.00	H	-39.64		
9400.00	H	-37.43		
11280.00	H	-36.31		
<b>Test mode:</b>	<b>PCS1900(GPRS)</b>		<b>Test channel:</b>	<b>Highest</b>
Frequency (MHz)	Spurious Emission		Limit (dBm)	Result
	Polarization	Level (dBm)		
3819.60	Vertical	-46.15	-13.00	Pass
5729.40	V	-46.41		
7639.20	V	-45.18		
9549.00	V	-44.74		
11458.80	V	-44.64		
3819.60	Horizontal	-42.17	-13.00	Pass
5729.40	H	-39.32		
7639.20	H	-38.50		
9549.00	H	-38.76		
11458.80	H	-36.81		

Remark:

1. The emission behaviour belongs to narrowband spurious emission.
2. Remark"---" means that the emission level is too low to be measured
3. The emission levels of below 1 GHz are 20dB lower than the limit and not show in test report.

<b>Test mode:</b>	<b>PCS1900(EGPRS)</b>		<b>Test channel:</b>	<b>Lowest</b>
Frequency (MHz)	Spurious Emission		Limit (dBm)	Result
	Polarization	Level (dBm)		
3700.40	Vertical	-44.48	-13.00	Pass
5550.60	V	-44.93		
7400.80	V	-44.82		
9251.00	V	-44.16		
11101.20	V	-43.87		
3700.40	Horizontal	-41.31	-13.00	Pass
5550.60	H	-38.23		
7400.80	H	-37.18		
9251.00	H	-38.24		
11101.20	H	-35.75		
<b>Test mode:</b>	<b>PCS1900(EGPRS)</b>		<b>Test channel:</b>	<b>Middle</b>
Frequency (MHz)	Spurious Emission		Limit (dBm)	Result
	Polarization	Level (dBm)		
3760.00	Vertical	-44.83	-13.00	Pass
5640.00	V	-45.83		
7520.00	V	-45.13		
9400.00	V	-44.19		
11280.00	V	-42.65		
3760.00	Horizontal	-43.35	-13.00	Pass
5640.00	H	-38.84		
7520.00	H	-38.14		
9400.00	H	-39.12		
11280.00	H	-36.28		
<b>Test mode:</b>	<b>PCS1900(EGPRS)</b>		<b>Test channel:</b>	<b>Highest</b>
Frequency (MHz)	Spurious Emission		Limit (dBm)	Result
	Polarization	Level (dBm)		
3819.60	Vertical	-45.31	-13.00	Pass
5729.40	V	-44.80		
7639.20	V	-44.23		
9549.00	V	-43.59		
11458.80	V	-42.41		
3819.60	Horizontal	-42.44	-13.00	Pass
5729.40	H	-38.04		
7639.20	H	-38.40		
9549.00	H	-36.85		
11458.80	H	-36.66		

Remark:

1. The emission behaviour belongs to narrowband spurious emission.
2. Remark"---" means that the emission level is too low to be measured
3. The emission levels of below 1 GHz are 20dB lower than the limit and not show in test report.



Test mode:		WCDMA Band V		Test channel:	Lowest
Frequency (MHz)	Spurious Emission		Limit (dBm)	Result	
	Polarization	Level (dBm)			
1652.80	Vertical	-48.03	-13.00	Pass	
2479.20	V	-47.97			
3305.60	V	-47.86			
4132.00	V	-47.16			
4958.40	V	-46.62			
1652.80	Horizontal	-43.14	-13.00	Pass	
2479.20	H	-42.50			
3305.60	H	-41.70			
4132.00	H	-40.51			
4958.40	H	-41.38			
Test mode:		WCDMA Band V		Test channel:	Middle
Frequency (MHz)	Spurious Emission		Limit (dBm)	Result	
	Polarization	Level (dBm)			
1672.80	Vertical	-48.13	-13.00	Pass	
2509.20	V	-48.11			
3345.60	V	-47.21			
4182.00	V	-48.49			
5018.40	V	-47.22			
1672.80	Horizontal	-41.41	-13.00	Pass	
2509.20	H	-42.84			
3345.60	H	-42.21			
4182.00	H	-40.35			
5018.40	H	-40.16			
Test mode:		WCDMA Band V		Test channel:	Highest
Frequency (MHz)	Spurious Emission		Limit (dBm)	Result	
	Polarization	Level (dBm)			
1693.20	Vertical	-48.78	-13.00	Pass	
2539.80	V	-47.89			
3386.40	V	-47.18			
4233.00	V	-48.86			
5079.60	V	-47.11			
1693.20	Horizontal	-41.06	-13.00	Pass	
2539.80	H	-43.03			
3386.40	H	-40.28			
4233.00	H	-40.57			
5079.60	H	-40.18			

Remark :

1. The emission behaviour belongs to narrowband spurious emission.
2. Remark"---" means that the emission level is too low to be measured
3. The emission levels of below 1 GHz are 20dB lower than the limit and not show in test report.

Test mode:	WCDMA Band II		Test channel:	Lowest
Frequency (MHz)	Spurious Emission		Limit (dBm)	Result
	Polarization	Level (dBm)		
3704.80	Vertical	-45.81	-13.00	Pass
5557.20	V	-46.03		
7409.60	V	-45.52		
9262.00	V	-43.14		
11114.40	V	-44.22		
3704.80	Horizontal	-41.38	-13.00	Pass
5557.20	H	-38.72		
7409.60	H	-38.50		
9262.00	H	-37.81		
11114.40	H	-35.44		
Test mode:	WCDMA Band II		Test channel:	Middle
Frequency (MHz)	Spurious Emission		Limit (dBm)	Result
	Polarization	Level (dBm)		
3760.00	Vertical	-45.37	-13.00	Pass
5640.00	V	-46.75		
7520.00	V	-44.42		
9400.00	V	-44.34		
11280.00	V	-41.97		
3760.00	Horizontal	-40.61	-13.00	Pass
5640.00	H	-37.83		
7520.00	H	-38.70		
9400.00	H	-37.52		
11280.00	H	-35.13		
Test mode:	WCDMA Band II		Test channel:	Highest
Frequency (MHz)	Spurious Emission		Limit (dBm)	Result
	Polarization	Level (dBm)		
3815.20	Vertical	-46.14	-13.00	Pass
5722.80	V	-45.50		
7630.40	V	-45.11		
9538.00	V	-44.35		
11445.60	V	-43.55		
3815.20	Horizontal	-42.74	-13.00	Pass
5722.80	H	-38.13		
7630.40	H	-38.34		
9538.00	H	-38.62		
11445.60	H	-36.27		

Remark:

1. The emission behaviour belongs to narrowband spurious emission.
2. Remark"---" means that the emission level is too low to be measured
3. The emission levels of below 1 GHz are 20dB lower than the limit and not show in test report.

#### 4.10 Frequency stability V.S. Temperature measurement

Test Requirement:	Part 2.1055(a)(1)(b), Part 22.355, Part 24.235, Part 27.54 RSS-132(5.3), RSS-133 (6.3), RSS-139 (6.4)
Test Method:	FCC Part2.1055(d)(1)(2), ANSI/TIA-603-E FCC KDB971168 D01 v03r01 Section 8, ANSI C63.26 clause 5.6.
Limit:	2.5ppm (Band V) Within the authorized bands of operation(Band II, Band IV)
Test setup:	<div style="text-align: center;"> <p>The diagram shows a block labeled 'Spectrum analyzer' on the left, containing a small graph of a signal. A line connects it to a block labeled 'Att.' (Attenuator). Another line connects 'Att.' to a large rectangular box labeled 'Temperature Chamber'. Inside the chamber is a block labeled 'EUT' (Equipment Under Test). A line connects 'EUT' to a block labeled 'Variable Power Supply' located below the chamber.</p> </div> <p><b>Note :</b> Measurement setup for testing on Antenna connector</p>
Test procedure:	<ol style="list-style-type: none"> <li>1. The equipment under test was connected to an external DC power supply and input rated voltage.</li> <li>2. RF output was connected to a frequency counter or spectrum analyzer via feed through attenuators.</li> <li>3. The EUT was placed inside the temperature chamber.</li> <li>4. Set the spectrum analyzer RBW low enough to obtain the desired frequency resolution and measure EUT 20 °C operating frequency as reference frequency.</li> <li>5. Turn EUT off and set the chamber temperature to –20 °C. After the temperature stabilized for approximately 30 minutes recorded the frequency.</li> <li>6. Repeat step measure with 10 °C increased per stage until the highest temperature of +50 °C reached.</li> </ol>
Test Instruments:	Refer to section 3 for details
Test mode:	Refer to section 4.1 for details
Test results:	Pass
Remark:	If all frequencies stability are comply with the lower limit, then all results can be considered qualified

## Measurement Data

Reference Frequency: GSM850 (GPRS 1 link) Middle channel=190 channel=836.6MHz					
Power supplied (Vdc)	Temperature ( °C)	Frequency error		Limit (ppm)	Result
		Hz	ppm		
7.4	-20	3	0.0037	2.5	Pass
	-10	22	0.0259		
	0	4	0.0051		
	10	14	0.0163		
	20	5	0.0060		
	30	3	0.0034		
	40	19	0.0225		
	50	27	0.0323		
Reference Frequency: GSM850 (EGPRS 1 link) Middle channel=190 channel=836.6MHz					
Power supplied (Vdc)	Temperature ( °C)	Frequency error		Limit (ppm)	Result
		Hz	ppm		
7.4	-20	6	0.0076	2.5	Pass
	-10	25	0.0296		
	0	14	0.0163		
	10	-1	0.0011		
	20	11	0.0127		
	30	5	0.0057		
	40	19	0.0226		
	50	22	0.0259		

<b>Reference Frequency: PCS1900 (GPRS 1 link) Middle channel=661 channel=1880MHz</b>					
Power supplied (Vdc)	Temperature ( °C)	Frequency error			Result
		Hz	ppm		
7.4	-20	21	0.0111	2.5	Pass
	-10	45	0.0239		
	0	31	0.0166		
	10	28	0.0151		
	20	20	0.0109		
	30	26	0.0137		
	40	44	0.0232		
	50	30	0.0159		
<b>Reference Frequency: PCS1900 (EGPRS 1 link) Middle channel=661 channel=1880MHz</b>					
Power supplied (Vdc)	Temperature ( °C)	Frequency error			Result
		Hz	ppm		
7.4	-20	21	0.0110	2.5	Pass
	-10	45	0.0237		
	0	19	0.0099		
	10	17	0.0091		
	20	16	0.0086		
	30	15	0.0079		
	40	45	0.0240		
	50	27	0.0144		

Reference Frequency: WCDMA Band V Middle channel=4183 channel=836.6MHz					
Power supplied (Vdc)	Temperature (°C)	Frequency error		Limit (ppm)	Result
		Hz	ppm		
7.4	-20	1	0.0015	2.5	Pass
	-10	15	0.0182		
	0	0	0.0000		
	10	11	0.0128		
	20	-1	-0.0016		
	30	6	0.0071		
	40	6	0.0076		
	50	13	0.0152		
Reference Frequency: WCDMA Band II Middle channel=9400 channel=1880.0MHz					
Power supplied (Vdc)	Temperature (°C)	Frequency error		Limit (ppm)	Result
		Hz	ppm		
7.4	-20	-2	-0.0009	2.5	Pass
	-10	9	0.0048		
	0	-4	-0.0023		
	10	16	0.0087		
	20	2	0.0010		
	30	2	0.0013		
	40	6	0.0030		
	50	15	0.0077		

#### 4.11 Frequency stability V.S. Voltage measurement

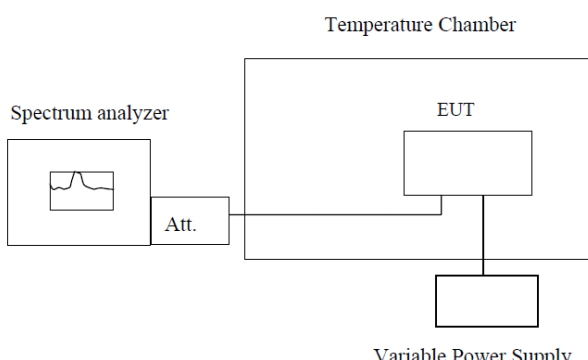
Test Requirement:	Part 2.1055(d)(1)(2), Part 22.355, Part 24.235, Part 27.54 RSS-132(5.3), RSS-133 (6.3), RSS-139 (6.4)
Test Method:	FCC Part2.1055(d)(1)(2), ANSI/TIA-603-E FCC KDB971168 D01 v03r01 Section 8, ANSI C63.26 clause 5.6.
Limit:	2.5ppm (Band V) Within the authorized bands of operation(Band II, Band IV)
Test setup:	 <p style="text-align: center;">Temperature Chamber</p> <p style="text-align: center;">Spectrum analyzer      Att.      EUT</p> <p style="text-align: center;">Variable Power Supply</p> <p><b>Note :</b> Measurement setup for testing on Antenna connector</p>
Test procedure:	<ol style="list-style-type: none"> <li>1. Set chamber temperature to 20 °C. Use a variable DC power source to power the EUT and set the voltage to rated voltage.</li> <li>2. Set the spectrum analyzer RBW low enough to obtain the desired frequency resolution and recorded the frequency.</li> <li>3. Reduce the input voltage to specified extreme voltage variation (+/- 15%) and endpoint, record the maximum frequency change.</li> </ol>
Test Instruments:	Refer to section 3 for details
Test mode:	Refer to section 4.1 for details
Test results:	Pass
Remark:	<ol style="list-style-type: none"> <li>1. Manufacturer specified the battery operating end point voltage is 6.3VDC, max voltage is 8.5VDC.</li> <li>2. If all frequencies stability are comply with the lower limit, then all results can be considered qualified</li> </ol>

## Measurement Data

Reference Frequency: GSM850 (GPRS 1 link) Middle channel=190 channel=836.6MHz					
Temperature ( °C)	Power supplied (Vdc)	Frequency error		Limit (ppm)	Result
		Hz	ppm		
20	8.5	25	0.0296	2.5	Pass
	7.4	25	0.0301		
	6.3	25	0.0295		
Reference Frequency: GSM850 (EGPRS 1 link) Middle channel=190 channel=836.6MHz					
Temperature ( °C)	Power supplied (Vdc)	Frequency error		Limit (ppm)	Result
		Hz	ppm		
20	8.5	-1	-0.0004	2.5	Pass
	7.4	16	0.0087		
	6.3	11	0.0057		

Reference Frequency: PCS1900 (GPRS 1 link) Middle channel=661 channel=1880MHz					
Temperature ( °C)	Power supplied (Vdc)	Frequency error		Limit (ppm)	Result
		Hz	ppm		
20	8.5	19	0.0226	2.5	Pass
	7.4	26	0.0316		
	6.3	21	0.0253		
Reference Frequency: PCS1900 (EGPRS 1 link) Middle channel=661 channel=1880MHz					
Temperature ( °C)	Power supplied (Vdc)	Frequency error		Limit (ppm)	Result
		Hz	ppm		
20	8.5	8	0.0042	2.5	Pass
	7.4	18	0.0098		
	6.3	16	0.0086		



Reference Frequency: WCDMA Band V Middle channel=4183 channel=836.6MHz					
Temperature (°C)	Power supplied (Vdc)	Frequency error		Limit (ppm)	Result
		Hz	ppm		
20	8.5	20	0.0241	2.5	Pass
	7.4	24	0.0292		
	6.3	23	0.0275		
Reference Frequency: WCDMA Band II Middle channel=940 channel=1880.0MHz					
Temperature (°C)	Power supplied (Vdc)	Frequency error		Limit (ppm)	Result
		Hz	ppm		
20	8.5	3	0.0014	2.5	Pass
	7.4	20	0.0106		
	6.3	17	0.0090		

----- **END OF REPORT** -----