



FCC TEST REPORT

FCC ID: SY4-A02026

On Behalf of

Shanghai Huace Navigation Technology LTD.

Geodetic GNSS Receiver

Model No.: i50

Prepared for : Shanghai Huace Navigation Technology LTD.
Address : 599 Gaojing Road, Building D, Shanghai 201702, China

Prepared By : Shenzhen Alpha Product Testing Co., Ltd.
Address : Building i, No.2, Lixin Road, Fuyong Street, Bao'an District, 518103,
Shenzhen, Guangdong, China

Report Number : A2006165-C01-R04
Date of Receipt : June 18, 2020
Date of Test : June 18, 2020 – July 15, 2020
Date of Report : July 15, 2020
Version Number : V0

TABLE OF CONTENTS

<u>Description</u>	<u>Page</u>
1 TEST SUMMARY	5
2 GENERAL INFORMATION	6
2.1 GENERAL DESCRIPTION OF EUT	6
2.2 RELATED SUBMITTAL(S) / GRANT (S)	8
2.3 TEST FACILITY	8
2.4 MEASUREMENT UNCERTAINTY	8
3 TEST INSTRUMENTS LIST	9
4 SYSTEM TEST CONFIGURATION	10
4.1 TEST MODE	10
4.2 CONFIGURATION OF TESTED SYSTEM	10
4.3 CONDUCTED AV OUTPUT POWER	11
4.4 PEAK-TO-AVERAGE RATIO	13
4.5 OCCUPY BANDWIDTH	17
4.6 MODULATION CHARACTERISTIC	22
4.7 OUT OF BAND EMISSION AT ANTENNA TERMINALS	22
4.8 ERP, EIRP MEASUREMENT	31
4.9 FIELD STRENGTH OF SPURIOUS RADIATION MEASUREMENT	39
4.10 FREQUENCY STABILITY V.S. TEMPERATURE MEASUREMENT	47
4.11 FREQUENCY STABILITY V.S. VOLTAGE MEASUREMENT	51

TEST REPORT DECLARATION

Applicant : Shanghai Huace Navigation Technology LTD.
 Address : 599 Gaojing Road, Building D, Shanghai 201702, China
 Manufacturer : Shanghai Huace Navigation Technology LTD.
 Address : 599 Gaojing Road, Building D, Shanghai 201702, China
 EUT Description : Geodetic GNSS Receiver
 (A) Model No. : i50
 (B) Trademark : 

Measurement Standard Used:

- FCC CFR Title 47 Part 2**
- FCC CFR Title 47 Part22 Subpart H**
- FCC CFR Title 47 Part24 Subpart E**
- ANSIC 63.26:2015**
- TIA/EIA-603-E:2016**

The device described above is tested by Shenzhen Alpha Product Testing Co., Ltd. to determine the maximum emission levels emanating from the device. The test results are contained in this test report and Shenzhen Alpha Product Testing Co., Ltd. is assumed of full responsibility for the accuracy and completeness of these tests.

After the test, our opinion is that EUT compliance with the requirement of the above standards.

This report applies to above tested sample only. This report shall not be reproduced in parts without written approval of Shenzhen Alpha Product Testing Co., Ltd.

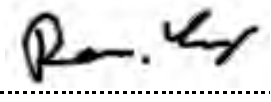
Tested by (name + signature).....: Reak Yang 
 Project Engineer

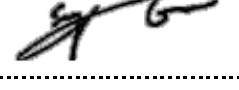
Approved by (name + signature).....: Simple Guan 
 Project Manager

Date of issue..... : July 15, 2020

Revision History

Revision	Issue Date	Revisions	Revised By
V0	July 15, 2020	Initial released Issue	Reak Yang

1 Test Summary

Test Item	Section in CFR 47	Result
RF Exposure (SAR)	Part 2.1310 Part 2.1091	Pass* (Please refer to SAR Report)
RF Output Power	Part 2.1046 Part 22.913 (a)(5) Part 24.232 (c)	Pass
Peak-to-Average Ratio	Part 2.1046 Part 22.913(d) Part 24.232 (d)	Pass
Modulation Characteristics	Part 2.1047	N/A
99% & -26 dB Occupied Bandwidth	Part 2.1049	Pass
Spurious Emissions at Antenna Terminal	Part 2.1051 Part 22.917 (a) Part 24.238 (a)	Pass
Field Strength of Spurious Radiation	Part 2.1053 Part 22.917 (a) Part 24.238 (a)	Pass
Out of band emission, Band Edge	Part 22.917 (a) Part 24.238 (a)	Pass
Frequency stability vs. temperature	Part 2.1055(a)(1)(b) Part 22.355 Part 24.235	Pass
Frequency stability vs. voltage	Part 2.1055(d)(1)(2) Part 22.355 Part 24.235	Pass

Pass: The EUT complies with the essential requirements in the standard.

2 General Information

2.1 General Description of EUT

Description/PMN	: Geodetic GNSS Receiver
Trademark	: 
Model Number/HVIN(s)	: i50
Diff	: N/A
Test Voltage	: DC 12-36V, 2A (for DC port) or DC 7.4V, 3400mAh (for replaceable lithium battery)
Support Networks	GPRS, EGPRS, WCDMA
Support Bands	GSM850, PCS1900, WCDMA Band V, WCDMA Band II
TX Frequency	GSM850: 824.20MHz-848.80MHz PCS1900: 1850.20MHz-1909.80MHz WCDMA Band V: 826.40MHz -846.60MHz WCDMA Band II: 1852.40MHz -1907.60MHz
GPRS Class	12
EGPRS Class	12
Modulation type	GPRS: GMSK EGPRS: GMSK/8PSK WCDMA Band II/V: QPSK
Antenna type	Internal antenna
Antenna gain	Internal Antenna, Maximum Gain is 0.775dBi for GSM Internal Antenna, Maximum Gain is 0.775dBi for WCDMA
Software version	: V1.0
Hardware version/FVIN	: i50_MAIN_V2.1

Remark: The worst-case simultaneous transmission configuration was evaluated with no non-compliance found.
Results in this report are only for 2G and 3G function, and there is no other transmitter involved.

Operation Frequency List:

GSM 850		PCS1900		WCDMA Band V		WCDMA Band II	
Channel	Frequency (MHz)	Channel	Frequency (MHz)	Channel	Frequency (MHz)	Channel	Frequency (MHz)
128	824.20	512	1850.20	4132	826.40	9262	1852.40
129	824.40	513	1850.40	4133	826.60	9263	1852.60
· ∴	· ∴	· ∴	· ∴	· ∴	· ∴	· ∴	· ∴
189	836.40	660	1879.80	4181	836.20	9399	1879.80
190	836.60	661	1880.00	4182	836.40	9400	1880.00
191	836.80	662	1880.20	4183	836.60	9401	1880.20
· ∴	· ∴	· ∴	· ∴	· ∴	· ∴	· ∴	· ∴
250	848.60	809	1909.60	4232	846.40	9537	1907.40
251	848.80	810	1909.80	4233	846.60	9538	1907.60

Regards to the operating frequency range over 10 MHz, the Lowest frequency, the middle frequency, and the highest frequency of channel were selected to perform the test, and the selected channel see below:

Final test channel:

GSM 850		PCS1900		WCDMA Band II		WCDMA Band V	
Channel	Frequency (MHz)	Channel	Frequency (MHz)	Channel	Frequency (MHz)	Channel	Frequency (MHz)
128	824.20	512	1850.20	9262	1852.40	4132	826.40
190	836.60	661	1880.00	9400	1880.00	4183	836.60
251	848.80	810	1909.80	9538	1907.60	4233	846.60

2.2 Related Submittal(s) / Grant (s)

This submittal(s) (test report) is filing to comply with Section Part 2, Part 22 subpart H, Part 24 subpart E of the FCC CFR 47, RSS-Gen, RSS-132, RSS-133, RSS-139 Rules, KDB 971168 D01 v03r01, ANSI C63.26 and TIA/EIA-603-E.

2.3 Test Facility

Shenzhen Alpha Product Testing Co., Ltd
Building i, No.2, Lixin Road, Fuyong Street, Bao'an District, 518103, Shenzhen, Guangdong, China

June 21, 2018 File on Federal Communication Commission
Registration Number: 293961
Designation Number: CN1236

July 15, 2019 Certificated by IC
Registration Number: CN0085

2.4 Measurement Uncertainty

Item	Uncertainty
Uncertainty for Power point Conducted Emissions Test	2.74dB
Uncertainty for Radiation Emission test in 3m chamber (below 30MHz)	2.13 dB(Polarize: V)
	2.57dB(Polarize: H)
Uncertainty for Radiation Emission test in 3m chamber (30MHz to 1GHz)	3.77dB(Polarize: V)
	3.80dB(Polarize: H)
Uncertainty for Radiation Emission test in 3m chamber (1GHz to 25GHz)	4.16dB(Polarize: H)
	4.13dB(Polarize: V)
Uncertainty for radio frequency	5.4×10^{-8}
Uncertainty for conducted RF Power	0.37dB
Uncertainty for temperature	0.2°C
Uncertainty for humidity	1%
Uncertainty for DC and low frequency voltages	0.06%

3 Test Instruments list

Equipment	Manufacturer	Model No.	Serial No.	Last cal.	Cal Interval
Bilog Antenna	Schwarzbeck	VULB 9168	VULB9168-438	2019.09.07	2Year
Horn Antenna	SCHWARZBECK	BBHA 9120 D	BBHA 9120 D(1201)	2020.04.12	2Year
Loop Antenna	SCHWARZBECK	FMZB 1519B	00059	2019.09.07	2Year
Filter	KANGMAI	ZLPF-LDC-1000-1959	1209002075	2019.09.06	1Year
Filter	WAINWRIGHT	WHKX2.80 /18G-12SS	SN1	2019.09.06	1Year
Filter	WAINWRIGHT	WHKX1.0G/15G -10SS	SN40	2019.09.06	1Year
RF Cable	Resenberger	Cable 4	N/A	2019.09.05	1Year
CMU200	ROHDE&SCHWARZ	CMU200	116785	2019.09.05	1Year
CMW500	ROHDE&SCHWARZ	CMW500	1201.0002K50-117239-sM	2019.09.05	1Year
Signal Analyzer	Agilent	N9020A	MY499100060	2019.09.05	1Year
vector Signal Generator	Agilent	N5182A	MY49060042	2019.09.05	1Year
vector Signal Generator	Agilent	E4438C	US44271917	2019.09.05	1Year
Amplifier	Agilent	8449B	3008A02664	2019.09.05	1Year
Test Receiver	ROHDE&SCHWARZ	ESR	1316.3003K03-102082-Wa	2019.09.06	1Year
9*6*6 anechoic chamber	CHENYU	9*6*6	N/A	/	/
RF Cable	Resenberger	Cable 1	N/A	2019.09.05	1Year
RF Cable	Resenberger	Cable 2	N/A	2019.09.06	1Year
RF Cable	Resenberger	Cable 3	N/A	2019.09.05	1Year
Power Sensor	Power Radio	RPR3006W	15100041SNO91	2019.09.06	1Year
20dB Attenuator	ICPROBING	IATS1	82347	2019.09.20	1Year
L.I.S.N.#1	SCHWARZBECK	NSLK8126	8126-466	2019.09.05	1Year
L.I.S.N.#2	ROHDE&SCHWARZ	ENV216	101043	2019.09.05	1Year
POWER DIVIDER	Mini-circuits	PD-2SF-0010	N/A	2019.09.20	1Year
POWER DIVIDER	Mini-circuits	PD-2SF-0010	N/A	2019.09.20	1Year
Temperature& Humidity test chamber	GZGONGWEN	GDS-250	080821	2019.09.10	1Year
Horn Antenna	SCHWARZBECK	BBHA 9120 D	BBHA 9120 D(1207)	2020.04.12	2Year
Bilog Antenna	Schwarzbeck	VULB 9168	VULB9168-627	2018.09.24	2Year
Spectrum analyzer	Agilent	E4407B	MY49510055	2019.09.05	1Year
Signal Analyzer	Agilent	N9020A	MY499100060	2019.09.05	1Year
Horn Antenna	SCHWARZBECK	BBHA 9170	00946	2019.09.07	1Year

4 System test configuration

4.1 Test mode

During all testing, EUT is in link mode with base station emulator at maximum power level. The spurious emission measurements were carried out in semi-anechoic chamber with 3-meter test range, and EUT is rotated on three test planes to find out the worst emission.

Test modes		
Band	Radiated	Conducted
GSM 850	<ul style="list-style-type: none"> ■ GPRS 1 link ■ EPRS 1 link 	<ul style="list-style-type: none"> ■ GPRS 1 link ■ EGPRS 1 link
PCS 1900	<ul style="list-style-type: none"> ■ GPRS 1 link ■ EGPRS 1 link 	<ul style="list-style-type: none"> ■ GPRS 1 link ■ EGPRS 1 link
WCDMA II	<ul style="list-style-type: none"> ■ RMC 12.2Kbps link 	<ul style="list-style-type: none"> ■ RMC 12.2Kbps link
WCDMA Band V	<ul style="list-style-type: none"> ■ RMC 12.2Kbps link 	<ul style="list-style-type: none"> ■ RMC 12.2Kbps link

Note: The maximum power levels are GPRS multi-slot class 12 mode for GSM link, EGPRS multi-slot class 12 mode for 8PSK link, RMC12.2Kbps mode for WCDMA Band V/II. only these modes were used for all tests.

4.2 Configuration of Tested System

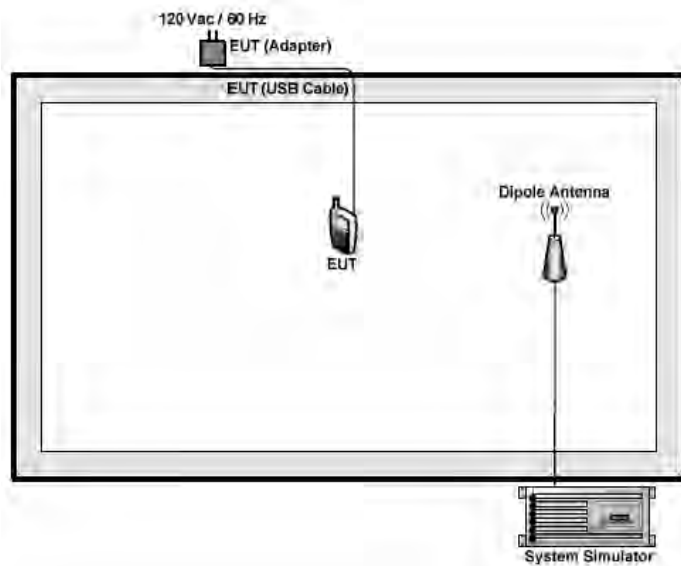

4.3 Conducted AV Output Power

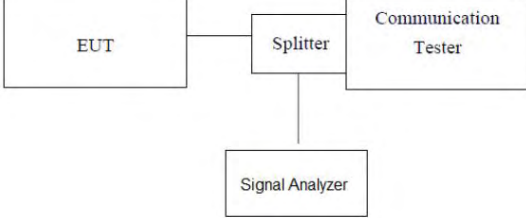
Test Requirement:	FCC part22.913(a)(5) , FCC part24.232(b)
Test Method:	FCC part2.1046, ANSI/TIA-603-E, ANSI C63.26 clause 5.2.4 FCC KDB971168 D01 v03r01 Section 5.2.
Limit:	GSM850, WCDMA Band V: 7W(ERP) PCS1900, WCDMA Band II: 2W(EIRP)
Test setup:	 <pre> graph LR EUT[EUT] --- Splitter[Splitter] Splitter --- CT[Communication Tester] Splitter --- SA[Signal Analyzer] </pre> <p><i>Note: Measurement setup for testing on Antenna connector</i></p>
Test Procedure:	<ol style="list-style-type: none"> 1. The transmitter output port was connected to base station. 2. The RF output of EUT was connected to the Signal Analyzer by RF cable and attenuator, the path loss was compensated to the results for each measurement. 3. Set EUT at maximum power through base station. 4. Select lowest, middle, and highest channels for each band and different modulation. 5. Measure the maximum frame average power.
Test Instruments:	Refer to section 3 for details
Test mode:	Refer to section 4.1 for details
Test results:	Pass

Measurement Data

Conducted Burst Power (dBm)						
Band	GSM850			PCS1900		
Channel	128	190	251	512	661	810
Frequency	824.20	836.60	848.80	1850.20	1880.00	1909.80
GPRS (GMSK, 1 TX slot)	30.68	30.83	30.93	28.45	28.39	28.62
GPRS (GMSK, 2 TX slot)	30.05	29.70	30.52	27.29	27.93	28.56
GPRS (GMSK, 3 TX slot)	28.58	30.67	29.05	26.69	26.68	28.14
GPRS (GMSK, 4 TX slot)	28.74	30.27	28.70	23.46	24.84	25.64
EGPRS (8PSK, 1 TX slot)	26.00	26.64	27.65	26.69	27.04	25.95
EGPRS (8PSK, 2 TX slot)	24.53	23.75	23.26	24.23	23.80	23.06
EGPRS (8PSK, 3 TX slot)	21.86	23.32	22.48	19.94	22.58	22.24
EGPRS (8PSK, 4 TX slot)	19.93	21.03	20.02	20.41	20.99	19.58

Burst Average Power (dBm)						
Band	WCDMA Band II			WCDMA Band V		
Channel	9262	9400	9538	4132	4183	4233
Frequency	1852.4	1880.0	1907.6	826.4	836.6	846.6
RMC 12.2Kbps	23.16	23.67	23.54	23.18	23.54	22.32
HSDPA Subtest-1	22.50	23.17	22.96	20.55	21.03	21.01
HSDPA Subtest-2	23.65	23.29	23.00	21.78	22.43	21.60
HSDPA Subtest-3	23.00	22.79	22.24	20.75	22.46	22.86
HSDPA Subtest-4	21.75	22.70	24.25	22.26	21.83	21.26
HSUPA Subtest-1	21.22	23.47	23.24	21.15	21.87	22.06
HSUPA Subtest-2	23.49	23.00	22.82	21.41	22.28	21.55
HSUPA Subtest-3	22.35	23.29	22.26	21.66	22.90	22.26
HSUPA Subtest-4	22.40	23.66	22.56	22.86	22.59	21.08
HSUPA Subtest-5	22.69	22.97	23.50	22.32	21.60	23.15
AMR	22.45	23.13	24.02	21.39	22.61	23.19

4.4 Peak-to-Average Ratio

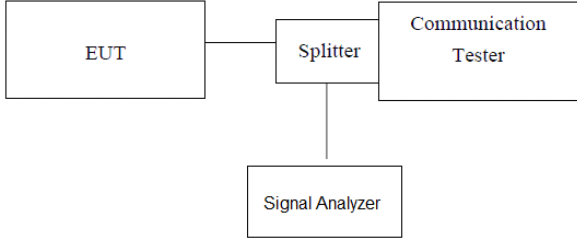
Test Requirement:	Part 22.913(d), FCC part24.232(d)
Test Method:	FCC part2.1046, ANSI/TIA-603-E, ANSI C63.26 Clause 5.2.3.4 FCC KDB971168 D01 v03r01 Section 5.7
Limit:	13db
Test setup:	 <pre> graph LR EUT[EUT] --- Splitter[Splitter] Splitter --- CT[Communication Tester] Splitter --- SA[Signal Analyzer] </pre> <p><i>Note: Measurement setup for testing on Antenna connector</i></p>
Test Procedure:	<ol style="list-style-type: none"> 1. The transmitter output port was connected to base station. 2. The RF output of EUT was connected to the Signal Analyzer by RF cable and attenuator, the path loss was compensated to the results for each measurement. 3. Set EUT at maximum power through base station. 4. Select lowest, middle, and highest channels for each band and different modulation. 5. Measure the maximum burst average power. 6. Record the maximum peak-to-average ratio value.
Test Instruments:	Refer to section 3 for details
Test mode:	Refer to section 4.1 for details
Test results:	Pass

Measurement data

Test mode	Peak to Average Ratio (dB)			Limit (dB)	Result
	Low Ch.	Middle Ch.	High Ch.		
GSM/TM1/GSM850(GPRS)	9.92	9.85	9.39	13	PASS
GSM/TM1/GSM1900(GPRS)	9.34	9.75	10.79	13	PASS

GPRS 850
Low Ch



Middle Ch



High Ch



GPRS 1900
Low Ch



Middle Ch



High Ch



Test mode	Peak to Average Ratio (dB)			Limit (dB)	Result
	Low Ch.	Middle Ch.	High Ch.		
GSM/TM1/GSM850(EGPRS)	10.04	11.29	11.16	13	PASS
GSM/TM1/GSM1900(EGPRS)	10.35	9.47	9.59	13	PASS

EGPRS 850
Low Ch



Middle Ch



High Ch



EGPRS 1900
Low Ch



Middle Ch



High Ch



Test mode	Peak to Average Ratio (dB)			Limit (dB)	Result
	Low Ch.	Middle Ch.	High Ch.		
WCDMA Band II	2.37	2.93	2.83	13	PASS
WCDMA Band V	3.37	3.48	4.13		

WCDMA Band II
Low Ch

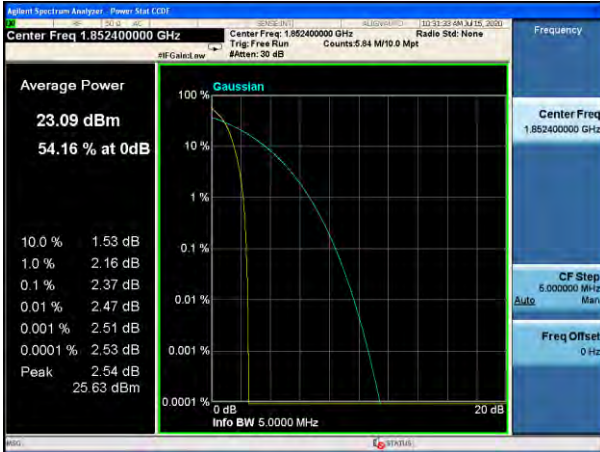

Middle Ch



High Ch



WCDMA Band V
Low Ch

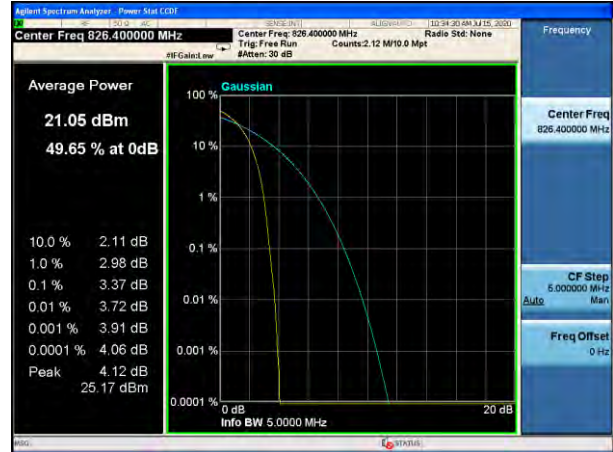

Middle Ch

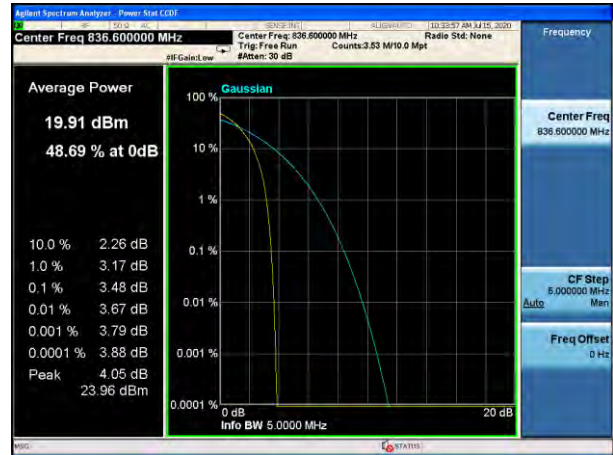

High Ch

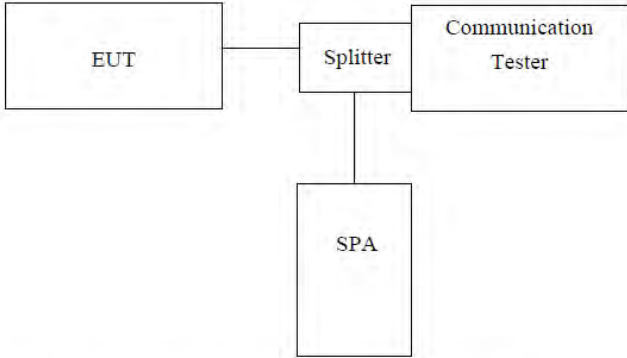

4.5 Occupy Bandwidth

Test Requirement:	Part 2.1049
Test Method:	KDB 971168 D01 v03r1 clause 4, FCC part2.1049, ANSI/TIA-603-E, ANSI C63.26 clause 5.4, RSS-Gen Section 6.7.
Test setup:	 <p style="text-align: center;"><i>Note: Measurement setup for testing on Antenna connector</i></p>
Test Procedure:	<ol style="list-style-type: none"> 1. The EUT's output RF connector was connected with a short cable to the spectrum analyzer 2. RBW was set to about 1% of emission BW, VBW= 3 times RBW. 3. -26dBc display line was placed on the screen (or 99% bandwidth), the occupied bandwidth is the delta frequency between the two points where the display line intersects the signal trace.
Test Instruments:	Refer to section 3 for details
Test mode:	Refer to section 4.1 for details
Test results:	Pass

Measurement Data

EUT Mode	Channel	Frequency (MHz)	99% Occupy bandwidth (KHz)	-26dB bandwidth (KHz)
GSM 850 (GPRS 1 link)	128	824.20	237.74	305.8
	190	836.60	248.00	313.4
	251	848.80	243.44	314.3
GSM 850 (EGPRS 1 link)	128	824.20	238.03	304.3
	190	836.60	241.86	314.9
	251	848.80	244.05	316.1
PCS 1900 (GPRS 1 link)	512	1850.20	241.88	296.1
	661	1880.00	245.21	316.0
	810	1909.80	243.52	313.2
PCS 1900 (EGPRS 1 link)	512	1850.20	239.38	307.8
	661	1880.00	248.05	313.1
	810	1909.80	242.85	312.2
WCDMA Band V (RMC 12.2Kbps link)	4132	826.40	4162.9	4740
	4183	836.60	4177.6	4759
	4233	846.60	4180.7	4721
WCDMA Band II (RMC 12.2Kbps link)	9262	1852.4	4169.8	4744
	9400	1880.0	4167.9	4733
	9538	1907.6	4147.0	4715

Test plot as follows:

GSM 850 (GPRS 1 link)	GSM 850 (EGPRS 1 link)
-----------------------	------------------------

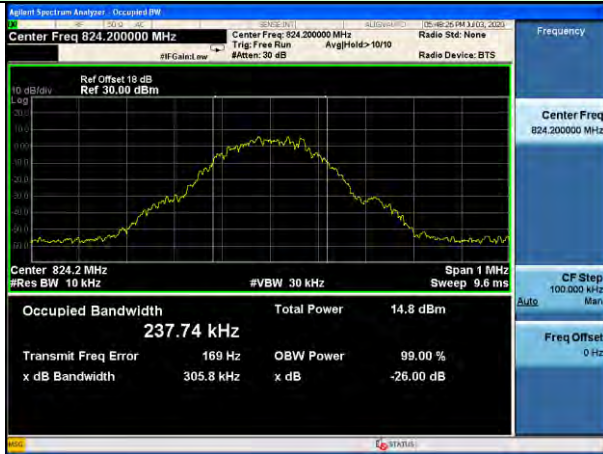

Lowest channel



Lowest channel



Middle channel



Middle channel



Highest channel

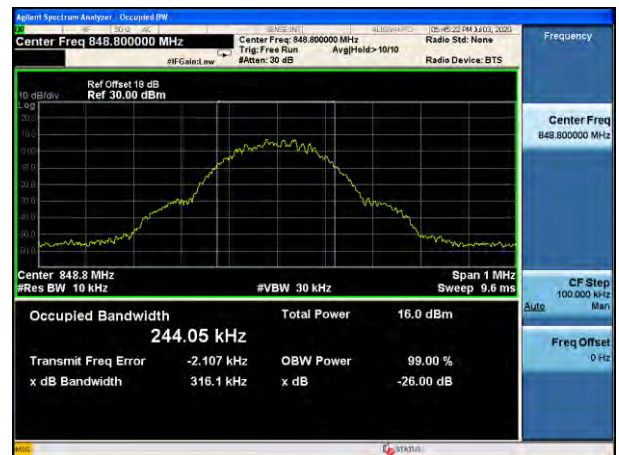

Highest channel

PCS 1900 (GPRS 1 link) PCS 1900 (EGPRS 1 link)



Lowest channel

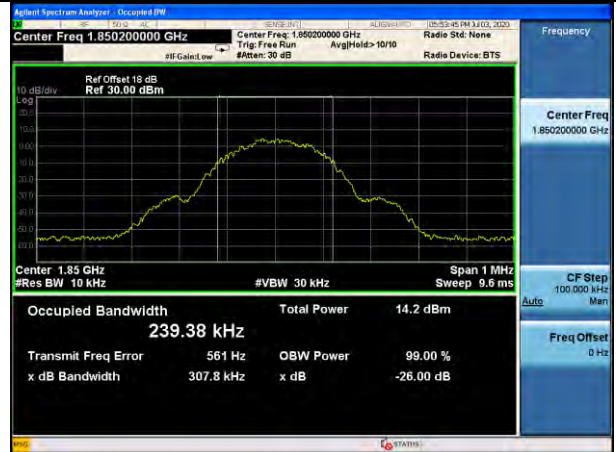

Lowest channel



Middle channel



Middle channel



Highest channel



Highest channel

WCDMA Band V (RMC 12.2Kbps link)

WCDMA Band II (RMC 12.2Kbps link)



Lowest channel



Lowest channel



Middle channel



Middle channel



Highest channel



Highest channel

4.6 Modulation Characteristic

According to FCC §2.1047(d), Part 22H, 24E & 27C, there is no specific requirement for digital modulation, therefore modulation characteristic is not presented.

According to RSS-132, RSS-133, RSS-199, the equipment certified under these standards shall employ digital modulation, but there is no specific requirement for digital modulation, therefore modulation characteristic is not presented.

4.7 Out of band emission at antenna terminals

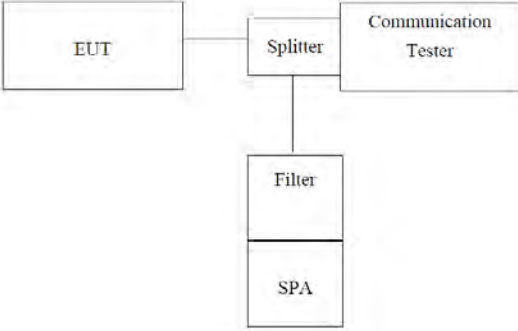
Test Requirement:	FCC part22.917(a), FCC part24.238(a)
Test Method:	KDB 971168 D01 v03r1 clause 6, FCC part2.1051, ANSI/TIA-603-E, ANSI C63.26 clause 5.7
Limit:	-13dBm
Test setup:	 <p><i>Note: Measurement setup for testing on Antenna connector</i></p>
Test Procedure:	<ol style="list-style-type: none"> 1 The RF output of the transceiver was connected to a spectrum analyzer through appropriate attenuation. 2 The resolution bandwidth of the spectrum analyzer was set at 1MHz, sufficient scans were taken to show the out of band Emissions if any up to 10th harmonic. 3 For the out of band: Set the RBW= 1MHz, VBW = 3MHz, Start=30MHz, Stop= 10th harmonic. 4 Band Edge Requirements: In the 1 MHz bands immediately outside and adjacent to the frequency block, a resolution bandwidth of at least 1 percent of the emission bandwidth of the fundamental emission of the transmitter may be employed to measure the out of band Emissions.
Test Instruments:	Refer to section 3 for details
Test mode:	Refer to section 4.1 for details
Test results:	Pass

Test plot as follows:

Test Mode: Traffic mode GSM 850 (GPRS 1 link)

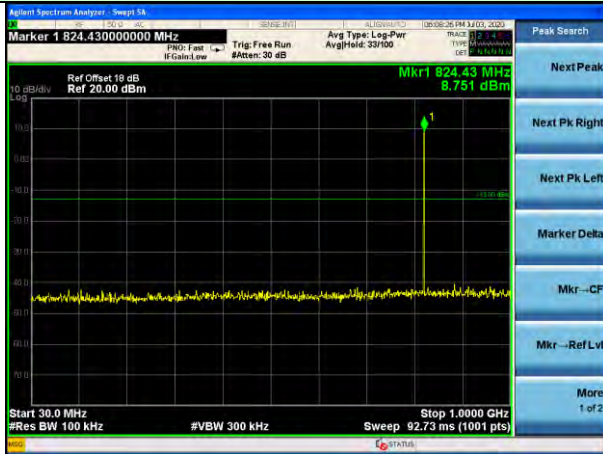

Lowest channel

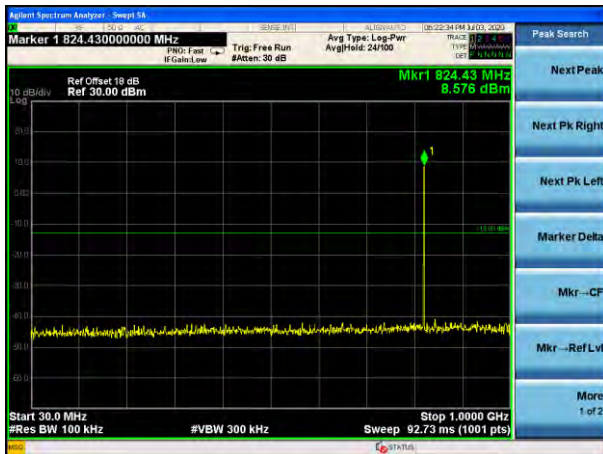

Middle channel

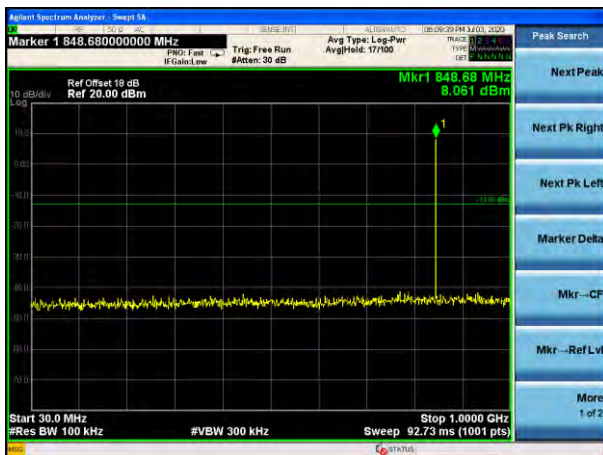

Highest channel

Test Mode: Traffic mode GSM 850 (EGPRS 1 link)

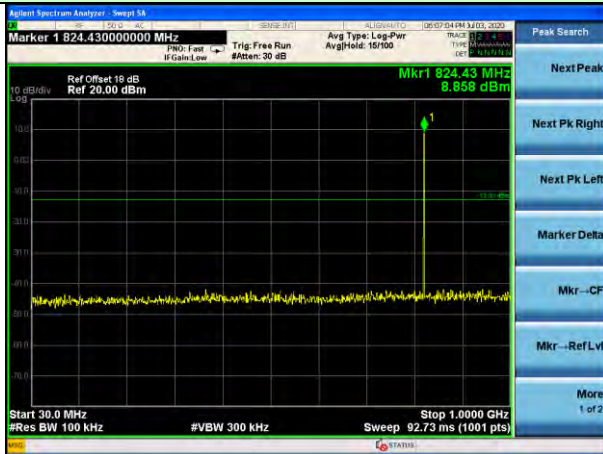

Lowest channel

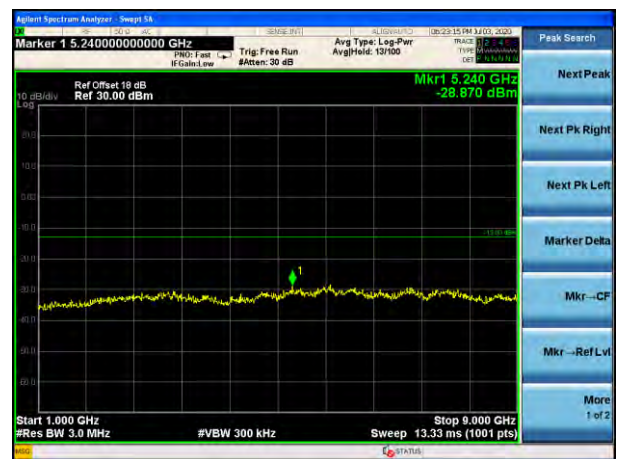
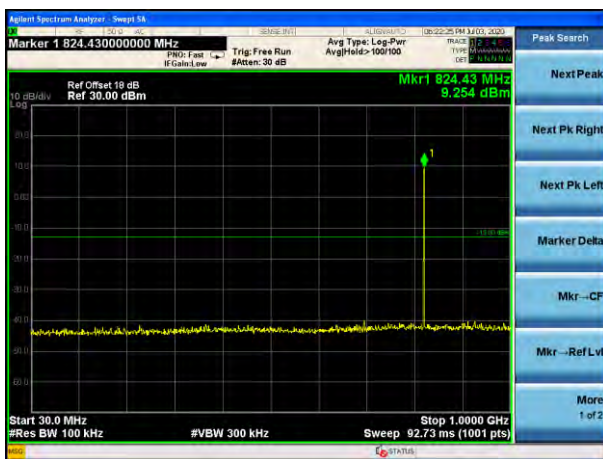

Middle channel

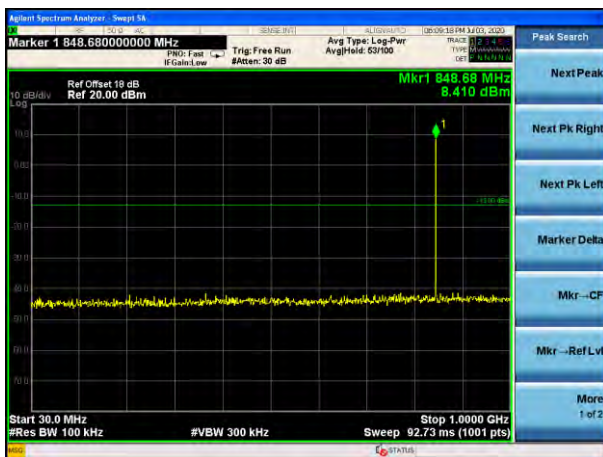

Highest channel

Test Mode: Traffic mode

PCS1900 (GPRS 1 link)

PCS1900 (EGPRS 1 link)



Lowest channel



Middle channel



Highest channel

Test Mode: Traffic mode

WCDMA Band V (RMC 12.2Kbps link)

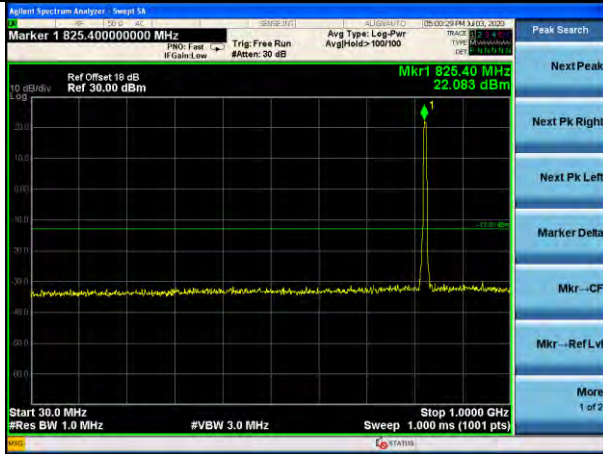

Lowest channel

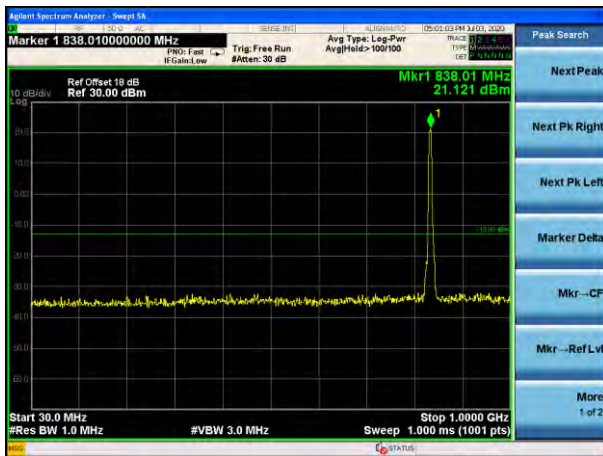

Middle channel

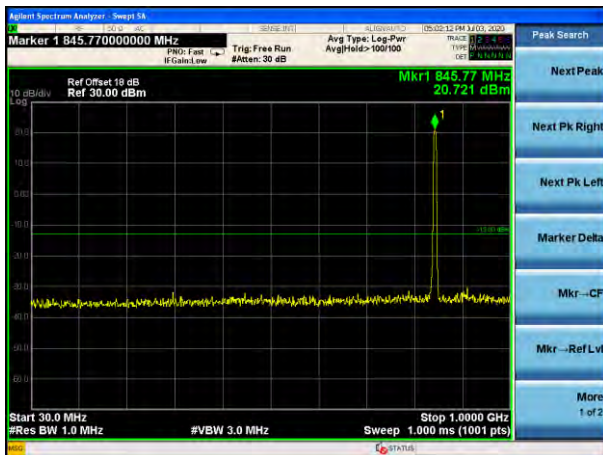

Highest channel

Test Mode: Traffic mode WCDMA Band II (RMC 12.2Kbps link)

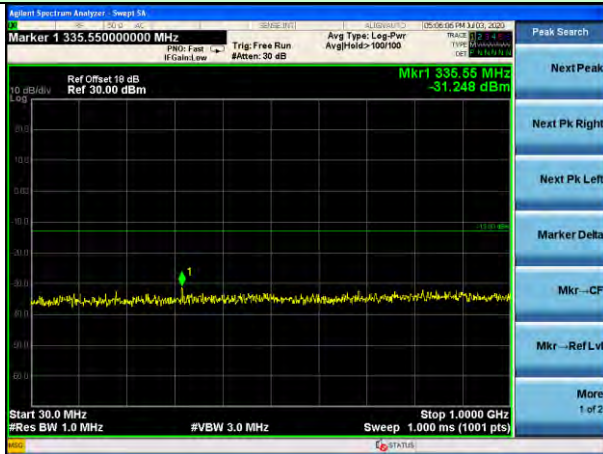

Lowest channel

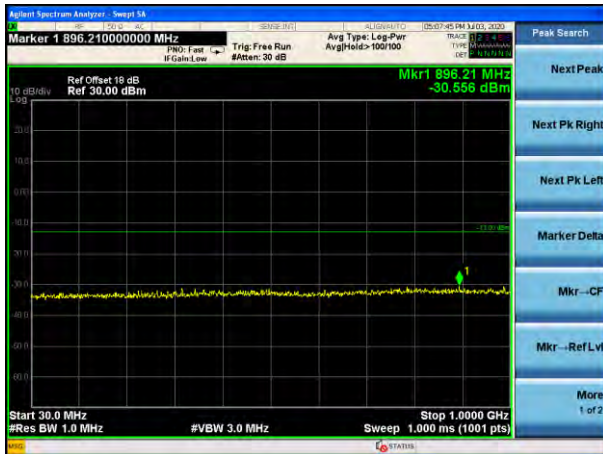

Middle channel

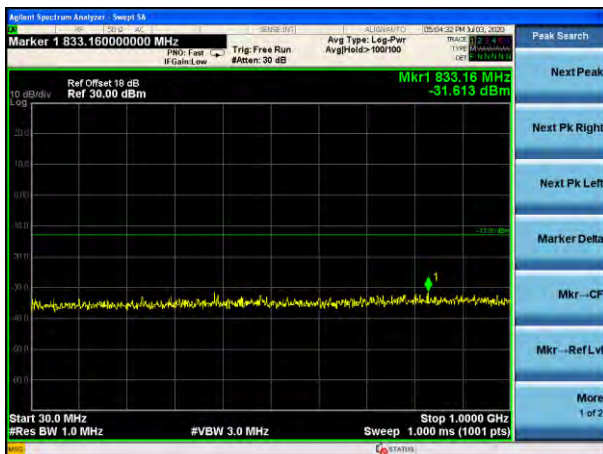

Highest channel

Band Edge:

Test Mode: Traffic mode GSM850 (GPRS 1 link)

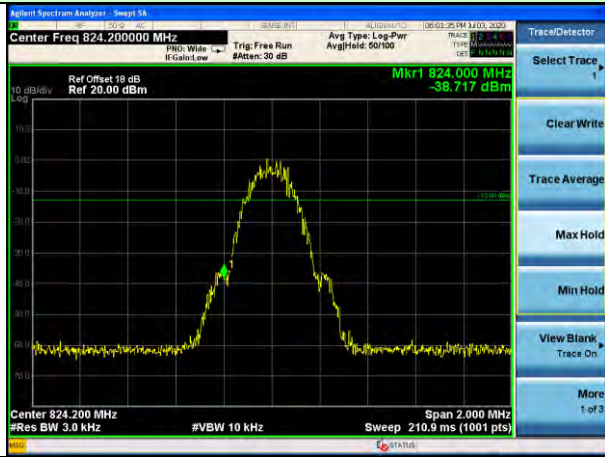

Lowest channel



Highest channel

Test Mode: Traffic mode GSM850 (EGPRS 1 link)

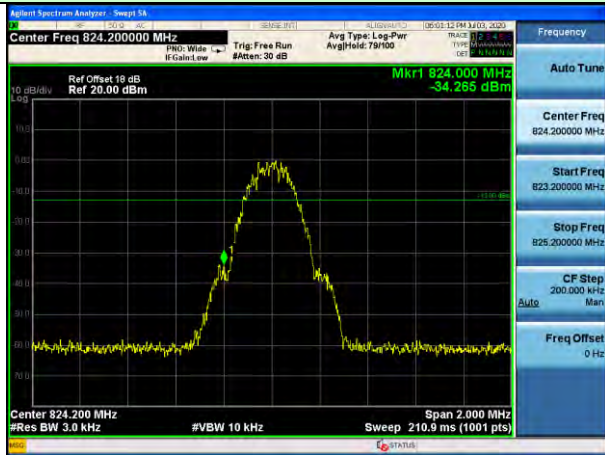

Lowest channel



Highest channel

Test Mode: Traffic mode PCS1900 (GPRS 1 link)

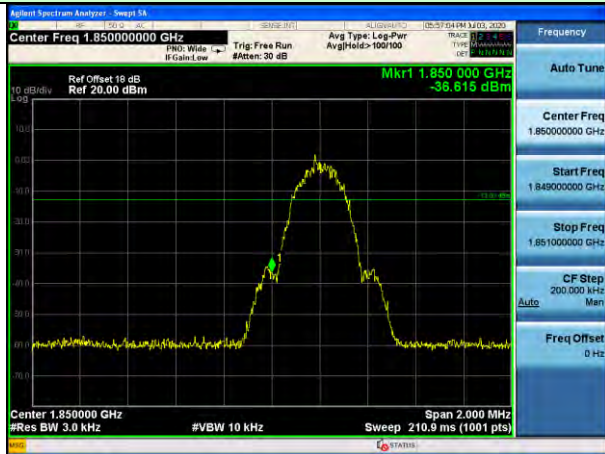

Lowest channel

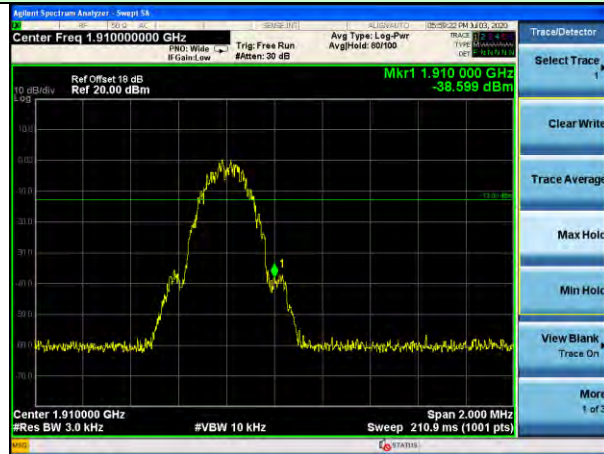

Highest channel

Test Mode: Traffic mode PCS1900 (EGPRS 1 link)

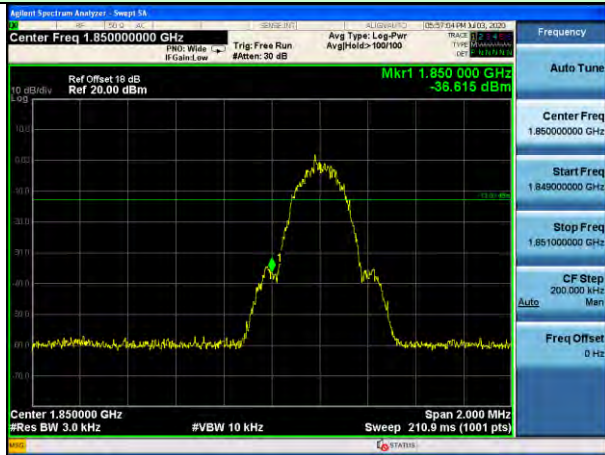

Lowest channel



Highest channel

Test Mode: Traffic mode WCDMA Band V (RMC 12.2Kbps link)



Lowest channel



Highest channel

Test Mode: Traffic mode WCDMA Band II (RMC 12.2Kbps link)



Lowest channel



Highest channel

4.8 ERP, EIRP Measurement

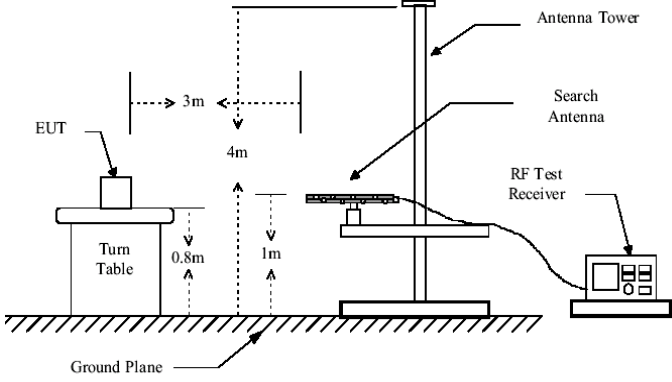
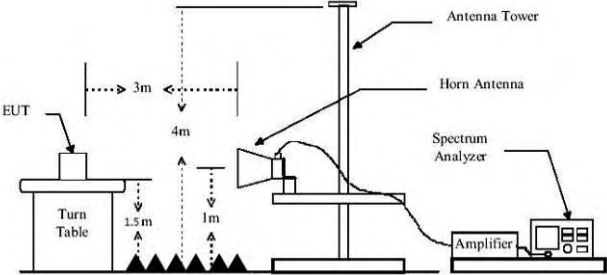
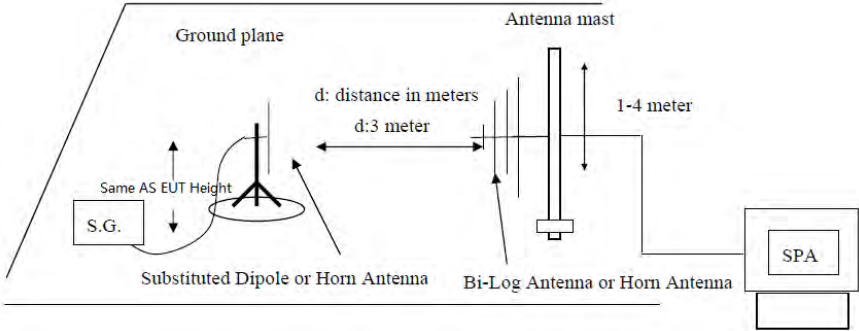
<p>Test Requirement:</p>	<p>FCC part22.913(a)(5), FCC part24.232(b)</p>
<p>Test Method:</p>	<p>KDB 971168 D01 v03r1 clause 5.8, FCC part2.1051, ANSI/TIA-603-E, ANSI C63.26 clause 5.7</p>
<p>Limit:</p>	<p>GSM850, WCDMA Band V: 7W PCS1900, WCDMA Band II: 2W</p>
<p>Test setup:</p>	<p>Below 1GHz</p>  <p>Above 1GHz</p>  <p>Substituted method:</p> 

Test Procedure:	<ol style="list-style-type: none"> 1. The EUT was placed on a non-conductive turntable using a non-conductive support. The radiated emission at the fundamental frequency was measured at 3 m with a test antenna and EMI spectrum analyzer. 2. During the measurement, the EUT was in communication with the station. The highest emission was recorded with the rotation of the turntable and the lowering of the test antenna from 4m to 1m. The reading was recorded and the field strength (E in dBuV/m) was calculated. 3. ERP in frequency band 824.2 –848.80.8MHz were measured using a substitution method. The EUT was replaced by a dipole antenna connected, the S.G. output was recorded and ERP was calculated as follows: $\text{ERP} = \text{S.G. output (dBm)} + \text{Antenna Gain (dBd)} - \text{Cable Loss (dB)}$ 4. EIRP in frequency band 1712.6-1752.4, 1850.2 –1909.8MHz were measured using a substitution method. The EUT was replaced by a horn antenna connected, the S.G. output was recorded and EIRP was calculated as follows: $\text{EIRP} = \text{S.G. output (dBm)} + \text{Antenna Gain (dBi)} - \text{Cable Loss (dB)}$
Test Instruments:	Refer to section 3 for details
Test mode:	Refer to section 4.1 for details
Test results:	Pass
Remark:	H,E1,E2 mean for EUT polarization of X, Y, Z

Measurement Data

EUT mode	Channel	EUT Pol.	Antenna Pol.	ERP(dBm)	Limit (dBm)	Result
GSM850 (GPRS 1 link)	Lowest	H	V	25.4	38.45	Pass
			H	28		
		E1	V	24.56		
			H	27.95		
		E2	V	24.59		
			H	27.91		
	Middle	H	V	23.69	38.45	Pass
			H	26.89		
		E1	V	24.46		
			H	27.93		
		E2	V	25.33		
			H	27.57		
	Highest	H	V	24.83	38.45	Pass
			H	27.43		
		E1	V	24.79		
			H	27.9		
		E2	V	24.42		
			H	27.22		

EUT mode	Channel	EUT Pol.	Antenna Pol.	ERP(dBm)	Limit (dBm)	Result
GSM850 (EGPRS 1 link)	Lowest	H	V	19.65	38.45	Pass
			H	23.84		
		E1	V	18.94		
			H	23.46		
		E2	V	19.06		
			H	23.86		
	Middle	H	V	19.2	38.45	Pass
			H	23.34		
		E1	V	18.99		
			H	22.94		
		E2	V	19.5		
			H	23.37		
	Highest	H	V	18.78	38.45	Pass
			H	23.56		
		E1	V	18.9		
			H	22.73		
		E2	V	19.14		
			H	23.48		

EUT mode	Channel	EUT Pol.	Antenna Pol.	EIRP (dBm)	Limit (dBm)	Result
PCS1900 (GPRS 1 link)	Lowest	H	V	24.42	33.01	Pass
			H	27.63		
		E1	V	24.31		
			H	28.16		
		E2	V	23.26		
			H	26.73		
	Middle	H	V	23.44	33.01	Pass
			H	25.67		
		E1	V	24.42		
			H	27.15		
		E2	V	24.39		
			H	26.94		
	Highest	H	V	24.85	33.01	Pass
			H	26.63		
		E1	V	23.83		
			H	28.1		
		E2	V	23.85		
			H	27.56		

EUT mode	Channel	EUT Pol.	Antenna Pol.	EIRP (dBm)	Limit (dBm)	Result
PCS1900 (EGPRS 1 link)	Lowest	H	V	23.26	33.01	Pass
			H	25.75		
		E1	V	22.61		
			H	25.21		
		E2	V	21.22		
			H	25.91		
	Middle	H	V	20.89	33.01	Pass
			H	25.76		
		E1	V	22.57		
			H	24.9		
		E2	V	20.93		
			H	24.77		
	Highest	H	V	23.48	33.01	Pass
			H	25.66		
		E1	V	24.31		
			H	25.86		
		E2	V	22.89		
			H	26.69		

EUT mode	Channel	EUT Pol.	Antenna Pol.	ERP(dBm)	Limit (dBm)	Result
WCDMA Band V	Lowest	H	V	16.5	38.45	Pass
			H	20.51		
		E1	V	16.47		
			H	19.3		
		E2	V	15.04		
			H	19.86		
	Middle	H	V	15.19	38.45	Pass
			H	19.53		
		E1	V	16.88		
			H	18.99		
		E2	V	15.21		
			H	17.93		
	Highest	H	V	17.35	38.45	Pass
			H	19.49		
		E1	V	16.14		
			H	20.45		
		E2	V	17.26		
			H	19.92		

EUT mode	Channel	EUT Pol.	Antenna Pol.	EIRP(dBm)	Limit (dBm)	Result
WCDMA Band II	Lowest	H	V	17.72	33.01	Pass
			H	20.77		
		E1	V	17.25		
			H	20.36		
		E2	V	16.72		
			H	20.74		
	Middle	H	V	17.5	33.01	Pass
			H	20.64		
		E1	V	17.6		
			H	19.69		
		E2	V	17.4		
			H	18.84		
	Highest	H	V	18.27	33.01	Pass
			H	21.06		
		E1	V	18.13		
			H	21.36		
		E2	V	18.15		
			H	21.11		

4.9 Field strength of spurious radiation measurement

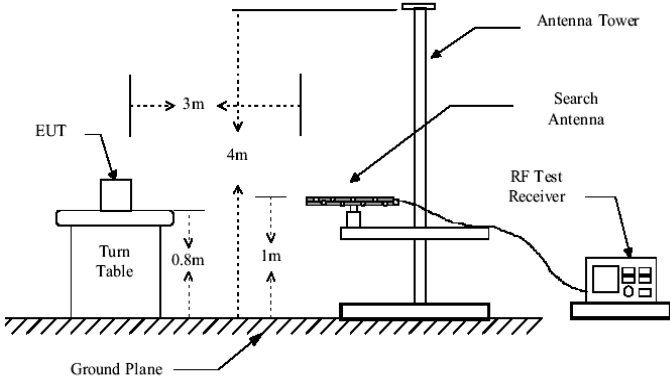
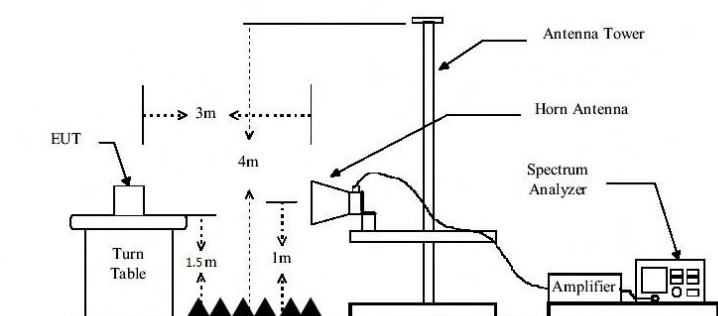
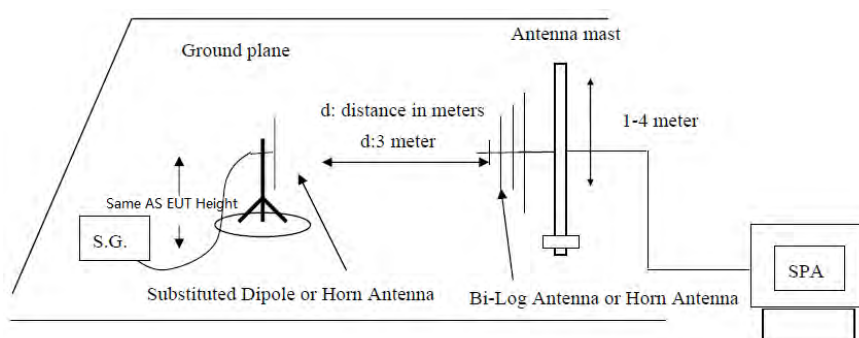
Test Requirement:	FCC part22.917(a), FCC part24.238(a)
Test Method:	KDB 971168 D01 v03r1 clause 7, FCC part2.1051, ANSI/TIA-603-E, ANSI C63.26 clause 5.5
Limit:	-13dBm
Test setup:	<p>Below 1GHz</p>  <p>Above 1GHz</p>  <p>Substituted method:</p> 

Test Procedure:	<ol style="list-style-type: none"> 1. The EUT was placed on a non-conductive turntable using a non-conductive support. The radiated emission at the fundamental frequency was measured at 3 m with a test antenna and EMI spectrum analyzer. 2. During the tests, the antenna height and the EUT azimuth were varied in order to identify the maximum level of emissions from the EUT. This maximization process was repeated with the EUT positioned in each of its three orthogonal orientations. 3. The frequency range up to tenth harmonic was investigated for each of three fundamental frequency (low, middle and high channels). Once spurious emission was identified, the power of the emission was determined using the substitution method. 4. The spurious emissions attenuation was calculated as the difference between radiated power at the fundamental frequency and the spurious emissions frequency. $\text{ERP / EIRP} = \text{S.G. output (dBm)} + \text{Antenna Gain(dB/dBi)} - \text{Cable Loss (dB)}$
Test Instruments:	Refer to section 3 for details
Test mode:	Refer to section 4.1 for details
Test results:	Pass

Measurement Data

Test mode:	GSM850(GPRS)		Test channel:	Lowest
Frequency (MHz)	Spurious Emission		Limit (dBm)	Result
	Polarization	Level (dBm)		
1648.40	Vertical	-47.13	-13.00	Pass
2472.60	V	-46.48		
3296.80	V	-48.00		
4121.00	V	-47.45		
4945.20	V	-46.51		
1648.40	Horizontal	-43.97	-13.00	Pass
2472.60	H	-42.93		
3296.80	H	-42.88		
4121.00	H	-39.82		
4945.20	H	-38.74		
Test mode:	GSM850(GPRS)		Test channel:	Middle
Frequency (MHz)	Spurious Emission		Limit (dBm)	Result
	Polarization	Level (dBm)		
1673.20	Vertical	-46.55	-13.00	Pass
2509.80	V	-47.42		
3346.40	V	-48.20		
4183.00	V	-47.36		
5019.60	V	-47.03		
1673.20	Horizontal	-43.96	-13.00	Pass
2509.80	H	-43.10		
3346.40	H	-42.27		
4183.00	H	-39.38		
5019.60	H	-39.05		
Test mode:	GSM850(GPRS)		Test channel:	Highest
Frequency (MHz)	Spurious Emission		Limit (dBm)	Result
	Polarization	Level (dBm)		
1697.60	Vertical	-47.24	-13.00	Pass
2546.40	V	-47.05		
3395.20	V	-47.63		
4244.00	V	-48.07		
5092.80	V	-46.90		
1697.60	Horizontal	-43.82	-13.00	Pass
2546.40	H	-43.24		
3395.20	H	-42.97		
4244.00	H	-40.04		
5092.80	H	-38.92		

Remark :

1. The emission behaviour belongs to narrowband spurious emission.
2. Remark"---" means that the emission level is too low to be measured
3. The emission levels of below 1 GHz are 20dB lower than the limit and not show in test report.

Test mode:	GSM850(EGPRS)		Test channel:	Lowest
Frequency (MHz)	Spurious Emission		Limit (dBm)	Result
	Polarization	Level (dBm)		
1648.40	Vertical	-47.65	-13.00	Pass
2472.60	V	-48.07		
3296.80	V	-47.70		
4121.00	V	-47.63		
4945.20	V	-46.99		
1648.40	Horizontal	-42.78	-13.00	Pass
2472.60	H	-42.59		
3296.80	H	-42.02		
4121.00	H	-40.79		
4945.20	H	-39.99		
Test mode:	GSM850(EGPRS)		Test channel:	Middle
Frequency (MHz)	Spurious Emission		Limit (dBm)	Result
	Polarization	Level (dBm)		
1673.20	Vertical	-48.48	-13.00	Pass
2509.80	V	-48.99		
3346.40	V	-48.96		
4183.00	V	-47.79		
5019.60	V	-46.46		
1673.20	Horizontal	-43.33	-13.00	Pass
2509.80	H	-43.13		
3346.40	H	-42.76		
4183.00	H	-41.36		
5019.60	H	-39.77		
Test mode:	GSM850(EGPRS)		Test channel:	Highest
Frequency (MHz)	Spurious Emission		Limit (dBm)	Result
	Polarization	Level (dBm)		
1697.60	Vertical	-48.19	-13.00	Pass
2546.40	V	-47.96		
3395.20	V	-47.30		
4244.00	V	-48.17		
5092.80	V	-46.67		
1697.60	Horizontal	-43.66	-13.00	Pass
2546.40	H	-43.06		
3395.20	H	-42.53		
4244.00	H	-41.88		
5092.80	H	-40.35		

Remark :

1. The emission behaviour belongs to narrowband spurious emission.
2. Remark"---" means that the emission level is too low to be measured
3. The emission levels of below 1 GHz are 20dB lower than the limit and not show in test report.

Test mode:	PCS1900(GPRS)		Test channel:	Lowest
Frequency (MHz)	Spurious Emission		Limit (dBm)	Result
	Polarization	Level (dBm)		
3700.40	Vertical	-44.57	-13.00	Pass
5550.60	V	-48.26		
7400.80	V	-46.08		
9251.00	V	-44.98		
11101.20	V	-43.98		
3700.40	Horizontal	-43.27	-13.00	Pass
5550.60	H	-39.36		
7400.80	H	-39.16		
9251.00	H	-38.82		
11101.20	H	-36.29		
Test mode:	PCS1900(GPRS)		Test channel:	Middle
Frequency (MHz)	Spurious Emission		Limit (dBm)	Result
	Polarization	Level (dBm)		
3760.00	Vertical	-46.71	-13.00	Pass
5640.00	V	-46.45		
7520.00	V	-45.33		
9400.00	V	-44.20		
11280.00	V	-42.78		
3760.00	Horizontal	-43.56	-13.00	Pass
5640.00	H	-40.28		
7520.00	H	-39.86		
9400.00	H	-38.25		
11280.00	H	-36.97		
Test mode:	PCS1900(GPRS)		Test channel:	Highest
Frequency (MHz)	Spurious Emission		Limit (dBm)	Result
	Polarization	Level (dBm)		
3819.60	Vertical	-46.65	-13.00	Pass
5729.40	V	-47.27		
7639.20	V	-46.21		
9549.00	V	-45.85		
11458.80	V	-45.69		
3819.60	Horizontal	-42.84	-13.00	Pass
5729.40	H	-40.17		
7639.20	H	-39.21		
9549.00	H	-40.18		
11458.80	H	-37.25		

Remark:

1. The emission behaviour belongs to narrowband spurious emission.
2. Remark"---" means that the emission level is too low to be measured
3. The emission levels of below 1 GHz are 20dB lower than the limit and not show in test report.

Test mode:	PCS1900(EGPRS)		Test channel:	Lowest
Frequency (MHz)	Spurious Emission		Limit (dBm)	Result
	Polarization	Level (dBm)		
3700.40	Vertical	-45.73	-13.00	Pass
5550.60	V	-46.36		
7400.80	V	-45.45		
9251.00	V	-44.15		
11101.20	V	-44.68		
3700.40	Horizontal	-41.73	-13.00	Pass
5550.60	H	-39.66		
7400.80	H	-38.39		
9251.00	H	-38.83		
11101.20	H	-37.01		
Test mode:	PCS1900(EGPRS)		Test channel:	Middle
Frequency (MHz)	Spurious Emission		Limit (dBm)	Result
	Polarization	Level (dBm)		
3760.00	Vertical	-45.50	-13.00	Pass
5640.00	V	-46.46		
7520.00	V	-46.30		
9400.00	V	-45.69		
11280.00	V	-43.69		
3760.00	Horizontal	-43.79	-13.00	Pass
5640.00	H	-39.14		
7520.00	H	-39.09		
9400.00	H	-39.56		
11280.00	H	-37.66		
Test mode:	PCS1900(EGPRS)		Test channel:	Highest
Frequency (MHz)	Spurious Emission		Limit (dBm)	Result
	Polarization	Level (dBm)		
3819.60	Vertical	-46.32	-13.00	Pass
5729.40	V	-45.77		
7639.20	V	-44.98		
9549.00	V	-44.20		
11458.80	V	-43.65		
3819.60	Horizontal	-43.34	-13.00	Pass
5729.40	H	-39.39		
7639.20	H	-40.02		
9549.00	H	-37.74		
11458.80	H	-37.28		

Remark:

1. The emission behaviour belongs to narrowband spurious emission.
2. Remark"---" means that the emission level is too low to be measured
3. The emission levels of below 1 GHz are 20dB lower than the limit and not show in test report.

Test mode:	WCDMA Band V		Test channel:	Lowest
Frequency (MHz)	Spurious Emission		Limit (dBm)	Result
	Polarization	Level (dBm)		
1652.80	Vertical	-48.80	-13.00	Pass
2479.20	V	-48.42		
3305.60	V	-49.20		
4132.00	V	-47.91		
4958.40	V	-47.22		
1652.80	Horizontal	-44.16	-13.00	Pass
2479.20	H	-42.97		
3305.60	H	-43.00		
4132.00	H	-41.16		
4958.40	H	-42.49		
Test mode:	WCDMA Band V		Test channel:	Middle
Frequency (MHz)	Spurious Emission		Limit (dBm)	Result
	Polarization	Level (dBm)		
1672.80	Vertical	-48.61	-13.00	Pass
2509.20	V	-49.19		
3345.60	V	-48.19		
4182.00	V	-48.78		
5018.40	V	-48.28		
1672.80	Horizontal	-43.00	-13.00	Pass
2509.20	H	-43.95		
3345.60	H	-42.83		
4182.00	H	-41.20		
5018.40	H	-41.17		
Test mode:	WCDMA Band V		Test channel:	Highest
Frequency (MHz)	Spurious Emission		Limit (dBm)	Result
	Polarization	Level (dBm)		
1693.20	Vertical	-49.58	-13.00	Pass
2539.80	V	-49.58		
3386.40	V	-47.41		
4233.00	V	-49.32		
5079.60	V	-47.94		
1693.20	Horizontal	-42.31	-13.00	Pass
2539.80	H	-43.62		
3386.40	H	-41.10		
4233.00	H	-41.67		
5079.60	H	-41.61		

Remark :

1. The emission behaviour belongs to narrowband spurious emission.
2. Remark"---" means that the emission level is too low to be measured
3. The emission levels of below 1 GHz are 20dB lower than the limit and not show in test report.

Test mode:	WCDMA Band II		Test channel:	Lowest
Frequency (MHz)	Spurious Emission		Limit (dBm)	Result
	Polarization	Level (dBm)		
3704.80	Vertical	-46.56	-13.00	Pass
5557.20	V	-44.00		
7409.60	V	-42.57		
9262.00	V	-41.63		
11114.40	V	-37.86		
3704.80	Horizontal	-41.94	-13.00	Pass
5557.20	H	-39.75		
7409.60	H	-39.47		
9262.00	H	-38.96		
11114.40	H	-37.13		
Test mode:	WCDMA Band II		Test channel:	Middle
Frequency (MHz)	Spurious Emission		Limit (dBm)	Result
	Polarization	Level (dBm)		
3760.00	Vertical	-46.97	-13.00	Pass
5640.00	V	-43.85		
7520.00	V	-43.19		
9400.00	V	-42.11		
11280.00	V	-37.71		
3760.00	Horizontal	-41.25	-13.00	Pass
5640.00	H	-39.64		
7520.00	H	-39.88		
9400.00	H	-38.69		
11280.00	H	-35.65		
Test mode:	WCDMA Band II		Test channel:	Highest
Frequency (MHz)	Spurious Emission		Limit (dBm)	Result
	Polarization	Level (dBm)		
3815.20	Vertical	-47.26	-13.00	Pass
5722.80	V	-43.95		
7630.40	V	-42.92		
9538.00	V	-40.26		
11445.60	V	-37.55		
3815.20	Horizontal	-43.48	-13.00	Pass
5722.80	H	-39.47		
7630.40	H	-39.34		
9538.00	H	-39.78		
11445.60	H	-37.42		

Remark:

1. The emission behaviour belongs to narrowband spurious emission.
2. Remark"---" means that the emission level is too low to be measured
3. The emission levels of below 1 GHz are 20dB lower than the limit and not show in test report.

4.10 Frequency stability V.S. Temperature measurement

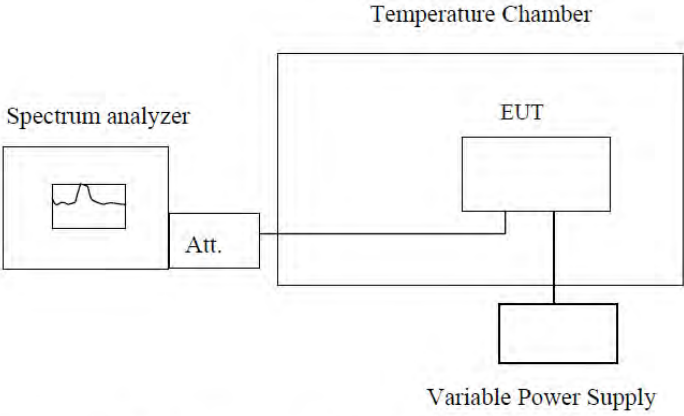
Test Requirement:	Part 2.1055(a)(1)(b), Part 22.355, Part 24.235
Test Method:	FCC Part2.1055(d)(1)(2), ANSI/TIA-603-E FCC KDB971168 D01 v03r01 Section 8, ANSI C63.26 clause 5.6.
Limit:	2.5ppm (Band V) Within the authorized bands of operation(Band II, Band IV)
Test setup:	 <p style="text-align: center;">Note : Measurement setup for testing on Antenna connector</p>
Test procedure:	<ol style="list-style-type: none"> 1. The equipment under test was connected to an external DC power supply and input rated voltage. 2. RF output was connected to a frequency counter or spectrum analyzer via feed through attenuators. 3. The EUT was placed inside the temperature chamber. 4. Set the spectrum analyzer RBW low enough to obtain the desired frequency resolution and measure EUT 20 °C operating frequency as reference frequency. 5. Turn EUT off and set the chamber temperature to –20 °C. After the temperature stabilized for approximately 30 minutes recorded the frequency. 6. Repeat step measure with 10 °C increased per stage until the highest temperature of +50 °C reached.
Test Instruments:	Refer to section 3 for details
Test mode:	Refer to section 4.1 for details
Test results:	Pass
Remark:	If all frequencies stability are comply with the lower limit, then all results can be considered qualified

Measurement Data

Reference Frequency: GSM850 (GPRS 1 link) Middle channel=190 channel=836.6MHz					
Power supplied (Vdc)	Temperature (°C)	Frequency error		Limit (ppm)	Result
		Hz	ppm		
7.4	-20	24	0.0281	2.5	Pass
	-10	-22	-0.0265		
	0	8	0.0100		
	10	-29	-0.0345		
	20	17	0.0209		
	30	12	0.0148		
	40	13	0.0161		
	50	-21	-0.0247		
Reference Frequency: GSM850 (EGPRS 1 link) Middle channel=190 channel=836.6MHz					
Power supplied (Vdc)	Temperature (°C)	Frequency error		Limit (ppm)	Result
		Hz	ppm		
7.4	-20	24	0.0289	2.5	Pass
	-10	-19	-0.0231		
	0	6	0.0073		
	10	-29	-0.0341		
	20	18	0.0220		
	30	15	0.0178		
	40	16	0.0185		
	50	-20	-0.0244		

Reference Frequency: PCS1900 (GPRS 1 link) Middle channel=661 channel=1880MHz					
Power supplied (Vdc)	Temperature (°C)	Frequency error		Limit (ppm)	Result
		Hz	ppm		
7.4	-20	33	0.0176	within authorized band	Pass
	-10	-2	-0.0012		
	0	-28	-0.0150		
	10	11	0.0061		
	20	-49	-0.0263		
	30	0	0.0001		
	40	-4	-0.0022		
	50	3	0.0016		
Reference Frequency: PCS1900 (EGPRS 1 link) Middle channel=661 channel=1880MHz					
Power supplied (Vdc)	Temperature (°C)	Frequency error		Limit (ppm)	Result
		Hz	ppm		
7.4	-20	26	0.0139	within authorized band	Pass
	-10	11	0.0059		
	0	-25	-0.0133		
	10	41	0.0220		
	20	-16	-0.0084		
	30	24	0.0129		
	40	-16	-0.0084		
	50	25	0.0133		

Reference Frequency: WCDMA Band V Middle channel=4183 channel=836.6MHz					
Power supplied (Vdc)	Temperature (°C)	Frequency error		Limit (ppm)	Result
		Hz	ppm		
7.4	-20	5	0.0058	2.5	Pass
	-10	-27	-0.0326		
	0	10	0.0124		
	10	-6	-0.0075		
	20	7	0.0079		
	30	13	0.0157		
	40	-20	-0.0238		
	50	17	0.0206		
Reference Frequency: WCDMA Band II Middle channel=9400 channel=1880.0MHz					
Power supplied (Vdc)	Temperature (°C)	Frequency error		Limit (ppm)	Result
		Hz	ppm		
7.4	-20	5	0.0025	within authorized band	Pass
	-10	-15	-0.0079		
	0	7	0.0035		
	10	-29	-0.0156		
	20	7	0.0039		
	30	12	0.0063		
	40	-15	-0.0079		
	50	12	0.0063		

4.11 Frequency stability V.S. Voltage measurement

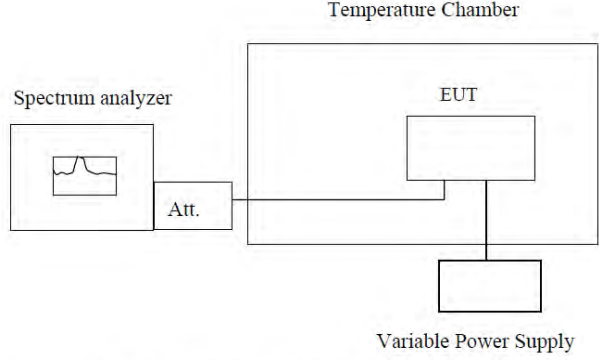
Test Requirement:	Part 2.1055(d)(1)(2), Part 22.355, Part 24.235
Test Method:	FCC Part2.1055(d)(1)(2), ANSI/TIA-603-E FCC KDB971168 D01 v03r01 Section 8, ANSI C63.26 clause 5.6.
Limit:	2.5ppm (Band V) Within the authorized bands of operation(Band II, Band IV)
Test setup:	 <p style="text-align: center;">Temperature Chamber</p> <p style="text-align: center;">Spectrum analyzer</p> <p style="text-align: center;">Att.</p> <p style="text-align: center;">EUT</p> <p style="text-align: center;">Variable Power Supply</p> <p>Note : Measurement setup for testing on Antenna connector</p>
Test procedure:	<ol style="list-style-type: none"> 1. Set chamber temperature to 25 °C. Use a variable DC power source to power the EUT and set the voltage to rated voltage. 2. Set the spectrum analyzer RBW low enough to obtain the desired frequency resolution and recorded the frequency. 3. Reduce the input voltage to specified extreme voltage variation (+/- 15%) and endpoint, record the maximum frequency change.
Test Instruments:	Refer to section 3 for details
Test mode:	Refer to section 4.1 for details
Test results:	Pass
Remark:	<ol style="list-style-type: none"> 1. Manufacturer specified the battery operating end point voltage is 6.1VDC, max voltage is 8.3VDC. 2. If all frequencies stability are comply with the lower limit, then all results can be considered qualified

Measurement Data

Reference Frequency: GSM850 (GPRS 1 link) Middle channel=190 channel=836.6MHz					
Temperature (°C)	Power supplied (Vdc)	Frequency error		Limit (ppm)	Result
		Hz	ppm		
25	8.3	24	0.0281	2.5	Pass
	7.2	28	0.0334		
	6.1	25	0.0298		
Reference Frequency: GSM850 (EGPRS 1 link) Middle channel=190 channel=836.6MHz					
Temperature (°C)	Power supplied (Vdc)	Frequency error		Limit (ppm)	Result
		Hz	ppm		
25	8.3	21	0.0252	2.5	Pass
	7.2	29	0.0348		
	6.1	23	0.0277		

Reference Frequency: PCS1900 (GPRS 1 link) Middle channel=661 channel=1880MHz					
Temperature (°C)	Power supplied (Vdc)	Frequency error		Limit (ppm)	Result
		Hz	ppm		
25	8.3	30	0.0158	within authorized band	Pass
	7.2	33	0.0174		
	6.1	30	0.0161		
Reference Frequency: PCS1900 (EGPRS 1 link) Middle channel=661 channel=1880MHz					
Temperature (°C)	Power supplied (Vdc)	Frequency error		Limit (ppm)	Result
		Hz	ppm		
25	8.3	23	0.0122	within authorized band	Pass
	7.2	28	0.0147		
	6.1	33	0.0173		

Reference Frequency: WCDMA Band V Middle channel=4183 channel=836.6MHz					
Temperature (°C)	Power supplied (Vdc)	Frequency error		Limit (ppm)	Result
		Hz	ppm		
25	8.3	20	0.0243	2.5	Pass
	7.2	29	0.0343		
	6.1	15	0.0183		
Reference Frequency: WCDMA Band II Middle channel=940 channel=1880.0MHz					
Temperature (°C)	Power supplied (Vdc)	Frequency error		Limit (ppm)	Result
		Hz	ppm		
25	8.3	30	0.0157	within authorized band	Pass
	7.2	28	0.0150		
	6.1	27	0.0144		

----- END OF REPORT-----