



FCC&IC TEST REPORT

FCC ID: SY4-A01020

On Behalf of

Shanghai Huace Navigation Technology LTD.

Geodetic GNSS Receiver

Model No.: i90, i90 Pro

Prepared for : Shanghai Huace Navigation Technology LTD.
Address : 599 Gaojing Road, Building D, Shanghai 201702, China

Prepared By : Shenzhen Alpha Product Testing Co., Ltd.
Address : Building i, No.2, Lixin Road, Fuyong Street, Bao'an District, 518103,
Shenzhen, Guangdong, China

Report Number : A1907162-C01-R01
Date of Receipt : August 15, 2019
Date of Test : August 15, 2019 – September 20, 2019
Date of Report : September 20, 2019
Version Number : V0

TABLE OF CONTENTS

Description	Page
1. Summary of Standards And Results	6
1.1. Description of Standards and Results	6
2. General Information.....	7
2.1. Description of Device (EUT).....	7
2.2. Accessories of Device (EUT)	8
2.3. Tested Supporting System Details	8
2.4. Block Diagram of connection between EUT and simulators	8
2.5. Test Mode Description.....	8
2.6. Test Conditions	9
2.7. Test Facility	9
2.8. Measurement Uncertainty.....	9
2.9. Test Equipment List	10
3. Maximum Peak Output power	11
3.1. Limit	11
3.2. Test Procedure	11
3.3. Test Setup.....	11
3.4. Test Result	11
4. Bandwidth.....	12
4.1. Limit	12
4.2. Test Procedure	12
4.3. Test Result	12
5. Carrier Frequency Separation.....	22
5.1. Limit	22
5.2. Test Procedure	22
5.3. Test Result	22
6. Number Of Hopping Channel.....	24
6.1. Limit	24
6.2. Test Procedure	24
6.3. Test Result	24
7. Dwell Time.....	27
7.1. Test limit	27
7.2. Test Procedure	27
7.3. Test Result	27
8. Radiated emissions.....	36
8.1. Limit	36
8.2. Block Diagram of Test setup	39
8.3. Test Procedure	40
8.4. Test Result	40
9. Band Edge Compliance	46

9.1. Block Diagram of Test Setup.....	46
9.2. Limit	46
9.3. Test Procedure	46
9.4. Test Result	46
10. Power Line Conducted Emissions	62
10.1. Block Diagram of Test Setup.....	62
10.2. Limit	62
10.3. Test Procedure	62
10.4. Test Result	63
11. Frequency stability.....	66
11.1. Test limit	66
11.2. Test Procedure	66
11.3. Test Setup.....	66
11.4. Test Results	66
12. Antenna Requirements.....	68
12.1. Limit	68
12.2. Result	68

TEST REPORT DECLARATION

Applicant : Shanghai Huace Navigation Technology LTD.
 Address : 599 Gaojing Road, Building D, Shanghai 201702, China
 Manufacturer : Shanghai Huace Navigation Technology LTD.
 Address : 599 Gaojing Road, Building D, Shanghai 201702, China
 EUT Description : Geodetic GNSS Receiver
 (A) Model No. : i90, i90 Pro
 (B) Trademark : 

Measurement Standard Used:

**FCC Rules and Regulations Part 15 Subpart C Section 15.247,
RSS-247 Issue 2, RSS-Gen Issue 5, ANSI C63.10:2013, CISPR 16-1-4:2010**

The device described above is tested by Shenzhen Alpha Product Testing Co., Ltd. to determine the maximum emission levels emanating from the device. The test results are contained in this test report and Shenzhen Alpha Product Testing Co., Ltd. is assumed of full responsibility for the accuracy and completeness of these tests.

After the test, our opinion is that EUT compliance with the requirement of the above standards.

This report applies to above tested sample only. This report shall not be reproduced in parts without written approval of Shenzhen Alpha Product Testing Co., Ltd.

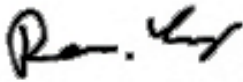
Tested by (name + signature).....: Reak Yang
 Project Engineer 

Approved by (name + signature).....: Simple Guan
 Project Manager 

Date of issue..... : September 20, 2019

Revision History

Revision	Issue Date	Revisions	Revised By
V0	September 20, 2019	Initial released Issue	Simple Guan

1. SUMMARY OF STANDARDS AND RESULTS

1.1. Description of Standards and Results

The EUT have been tested according to the applicable standards as referenced below:

Test Item	Standards Paragraph	Result
Maximum Peak Output Power	FCC Part 15: 15.247(b)(1) RSS-247(5.4 b) ANSI C63.10 :2013	P
Bandwidth	FCC Part 15: 15.215 RSS-247(5.1 a) ANSI C63.10 :2013	P
Carrier Frequency Separation	FCC Part 15: 15.247(a)(1) RSS-247(5.1 b) ANSI C63.10 :2013	P
Number Of Hopping Channel	FCC Part 15: 15.247(a)(1) RSS-247(5.1 d) ANSI C63.10 :2013	P
Dwell Time	FCC Part 15: 15.247(a)(1) RSS-247(5.1 d) ANSI C63.10 :2013	P
Radiated Emission	FCC Part 15: 15.209 FCC Part 15: 15.247(d) RSS-Gen(8.9), RSS-247(5.5) ANSI C63.10 :2013	P
Band Edge Compliance	FCC Part 15: 15.247(d) RSS-Gen(8.9), RSS-247(5.5) ANSI C63.10 :2013	P
Power Line Conducted Emissions	FCC Part 15: 15.207 RSS-GEN(8.8) ANSI C63.10 :2013	P
Frequency stability	RSS-GEN(6.11)	P
Antenna requirement	FCC Part 15: 15.203 RSS-GEN(6.8)	P
Note:	1. P is an abbreviation for Pass. 2. F is an abbreviation for Fail. 3. N/A is an abbreviation for Not Applicable.	

2. GENERAL INFORMATION

2.1. Description of Device (EUT)

Description/PMN : Geodetic GNSS Receiver

Model : i90, i90 Pro

Number/FVIN(s)

Diff. : Both models are the same, only the GPS modules inside are different, the result of this report belongs to i90.

Trademark : 

Test Voltage : DC 7.4V from battery or 9-28VDC, DC 12V From adapter

Radio Technology : Bluetooth 4.1 EDR

Operation frequency : 2402-2480MHz

Channel No. : 79 Channels

Modulation type : GFSK, $\pi/4$ DQPSK, 8- DPSK

Antenna Type : Internal antenna, Maximum Gain is 2dBi for BT

Software version : 2.0.7

Hardware Version/FVIN : V1.2

Remark: The worst-case simultaneous transmission configuration was evaluated with no non-compliance found. Results in this report are only for Bluetooth 4.1 EDR function, and there is no other transmitter involved.

2.2. Accessories of Device (EUT)

Accessories1 : /
 Manufacturer : /
 Model : /
 Input : /
 Output : /

2.3. Tested Supporting System Details

No.	Description	Manufacturer	Model	Serial Number	Certification or DOC
1.	Notebook	ACER	ZQT	N/A	DOC

2.4. Block Diagram of connection between EUT and simulators

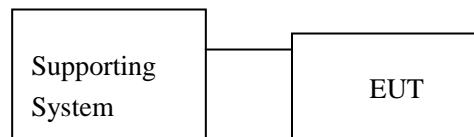

2.5. Test Mode Description

Tested mode, channel, and data rate information		
Mode	Channel	Frequency (MHz)
GFSK	Low :CH1	2402
	Middle: CH40	2441
	High: CH79	2480
π /4 DQPSK	Low :CH1	2402
	Middle: CH40	2441
	High: CH79	2480
8- DPSK	Low :CH1	2402
	Middle: CH40	2441
	High: CH79	2480

2.6. Test Conditions

Items	Required	Actual
Temperature range:	15-35°C	25°C
Humidity range:	25-75%	56%
Pressure range:	86-106kPa	98kPa

2.7. Test Facility

Shenzhen Alpha Product Testing Co., Ltd

Building i, No.2, Lixin Road, Fuyong Street, Bao'an District, 518103,
Shenzhen, Guangdong, China

June 21, 2018 File on Federal Communication Commission

Registration Number: 293961

Designation Number: CN1236

July 15, 2019 Certificated by IC

Registration Number: 12135A

2.8. Measurement Uncertainty

(95% confidence levels, k=2)

Item	Uncertainty
Uncertainty for Power point Conducted Emissions Test	2.74dB
Uncertainty for Radiation Emission test in 3m chamber (below 30MHz)	2.13 dB(Polarize: V)
	2.57dB(Polarize: H)
Uncertainty for Radiation Emission test in 3m chamber (30MHz to 1GHz)	3.77dB(Polarize: V)
	3.80dB(Polarize: H)
Uncertainty for Radiation Emission test in 3m chamber (1GHz to 25GHz)	4.16dB(Polarize: H)
	4.13dB(Polarize: V)
Uncertainty for radio frequency	5.4×10^{-8}
Uncertainty for conducted RF Power	0.37dB
Uncertainty for temperature	0.2°C
Uncertainty for humidity	1%
Uncertainty for DC and low frequency voltages	0.06%

2.9. Test Equipment List

Equipment	Manufacture	Model No.	Serial No.	Last cal.	Cal Interval
3m Semi-Anechoic	ETS-LINDGREN	N/A	SEL0017	2018.09.21	1 Year
Receiver	R&S	ESCI	1166.5950K03-1011	2018.09.21	1 Year
Receiver	R&S	ESCI	101202	2018.09.21	1 Year
Bilog Antenna	Schwarzbeck	VULB 9168	VULB9168-438	2018.04.13	2Year
Horn Antenna	EMCO	3115	640201028-06	2018.04.13	2Year
Active Loop Antenna	Beijing Daze	ZN30900A	SEL0097	2018.04.13	2Year
Cable	Resenberger	N/A	No.1	2018.09.21	1 Year
Cable	SCHWARZBECK	N/A	No.2	2018.09.21	1 Year
Cable	SCHWARZBECK	N/A	No.3	2018.09.21	1 Year
Pre-amplifier	Schwarzbeck	BBV9743	9743-019	2018.09.21	1 Year
Pre-amplifier	R&S	AFS33-18002650-30-8P-44	SEL0080	2018.09.21	1 Year
Temperature controller	Terchy	MHQ	120	2018.09.21	1 Year
L.I.S.N.#1	Schwarzbeck	NSLK8126	8126466	2018.09.21	1 Year
L.I.S.N.#2	ROHDE&SCHWARZ	ENV216	101043	2018.09.21	1 Year
20db Attenuator	ICPROBING	IATS1	82347	2018.09.21	1 Year
Horn Antenna	SCHWARZBECK	BBHA 9170	BBHA 9170294	2018.04.13	2 Year
Power Meter	Agilent	E9300A	MY41496625	2018.09.21	1 Year
Temperature Chamber	Gongwen	GDS-250	080943	2019.09.10	1 Year
Switching Mode Power Supply	JUNKE	JK12010S	20140927-6	2019.09.10	1 Year

3. MAXIMUM PEAK OUTPUT POWER

3.1.Limit

Please refer FCC part 15.247 & RSS-247..

For frequency hopping systems operating in the 2400-2483.5 MHz band employing at least 75 non-overlapping hopping channels, and all frequency hopping systems in the 5725-5850 MHz band: 1 watt. For all other frequency hopping systems in the 2400-2483.5 MHz band: 0.125 watts, the e.i.r.p shall not exceed 4W

3.2.Test Procedure

The transmitter output is connected to the RF Power meter. The Power meter is set to the peak power detection.

3.3.Test Setup

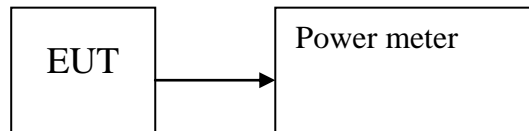

3.4.Test Result

Mode	Freq (MHz)	PK Output Power (dBm)	Limit (dBm)	Result
GFSK	2402	1.717	21	Pass
	2441	6.945	21	Pass
	2480	1.069	21	Pass
π /4 DQPSK	2402	3.143	21	Pass
	2441	1.275	21	Pass
	2480	2.849	21	Pass
8- DPSK	2402	2.327	21	Pass
	2441	0.544	21	Pass
	2480	1.793	21	Pass
Conclusion: PASS				

4. BANDWIDTH

4.1.Limit

Intentional radiators operating under the alternative provisions to the general emission limits, as contained in RSS-GEN, FCC Section 15.247(a)(1), must be designed to ensure that the 20 dB bandwidth of the emission, or whatever bandwidth may otherwise be specified in the specific rule section under which the equipment operates, is contained within the frequency band designated in the rule section under which the equipment is operated.

4.2.Test Procedure

The RF output of EUT was connected to the spectrum analyzer by RF cable and attenuator. The bandwidth of the fundamental frequency was measured by spectrum analyzer with 30kHz RBW and 100kHz VBW. The 20dB bandwidth is defined as the total spectrum the power of which is higher than peak power minus 20dB.

4.3.Test Result

Condition	Mode	Frequency (MHz)	Antenna	99% OBW (MHz)	-20 dB Bandwidth (MHz)	Limit -20 dB Bandwidth (MHz)	Verdict
NVNT	1-DH1	2402	Ant 1	0.8625	0.8408	/	Pass
NVNT	1-DH1	2441	Ant 1	0.8161	0.808	/	Pass
NVNT	1-DH1	2480	Ant 1	0.8141	0.7644	/	Pass
NVNT	2-DH1	2402	Ant 1	1.1527	1.196	/	Pass
NVNT	2-DH1	2441	Ant 1	1.1105	1.1708	/	Pass
NVNT	2-DH1	2480	Ant 1	1.1371	1.2016	/	Pass
NVNT	3-DH1	2402	Ant 1	1.0477	1.1514	/	Pass
NVNT	3-DH1	2441	Ant 1	1.1201	1.1576	/	Pass
NVNT	3-DH1	2480	Ant 1	1.0801	1.1544	/	Pass

OBW NVNT 1-DH1 2402MHz Ant1

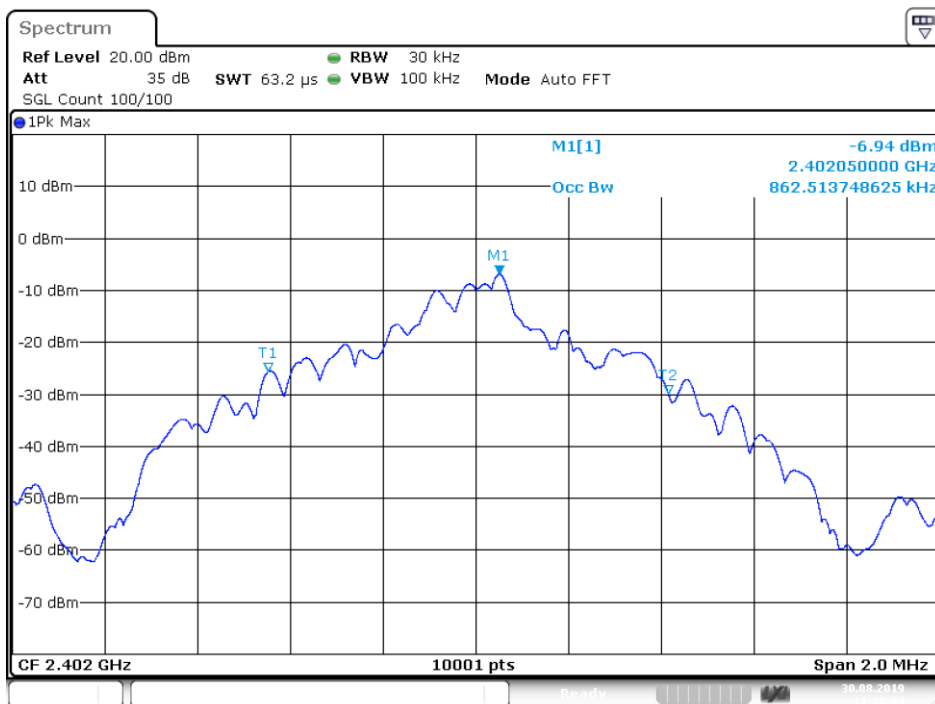

Date: 30.AUG.2019 11:38:04

-20 dB BW NVNT 1-DH1 2402MHz Ant1

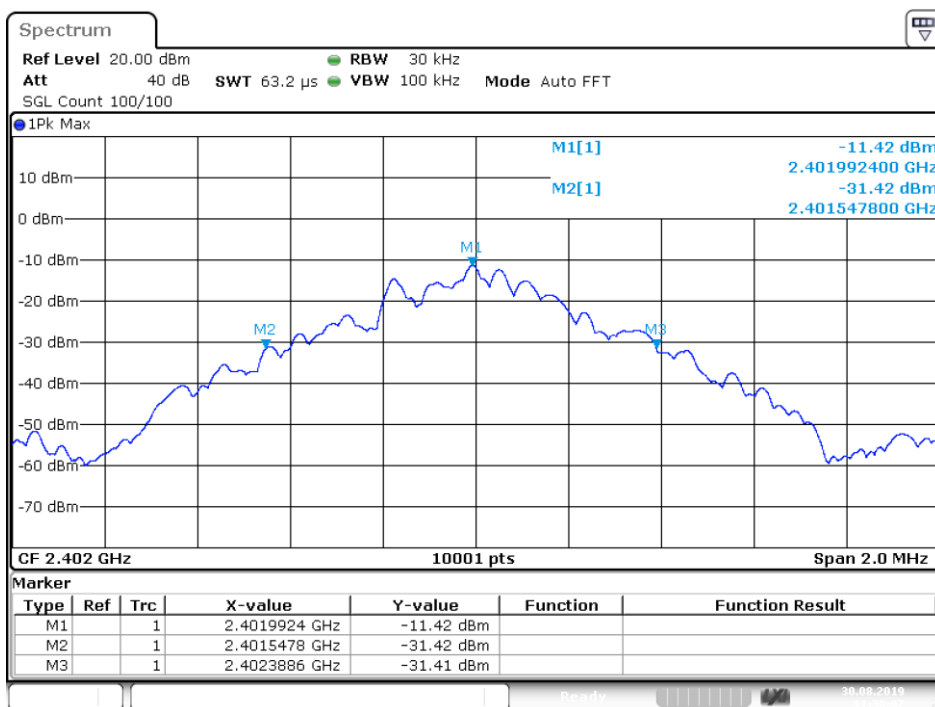

Date: 30.AUG.2019 11:38:07

OBW NVNT 1-DH1 2441MHz Ant1

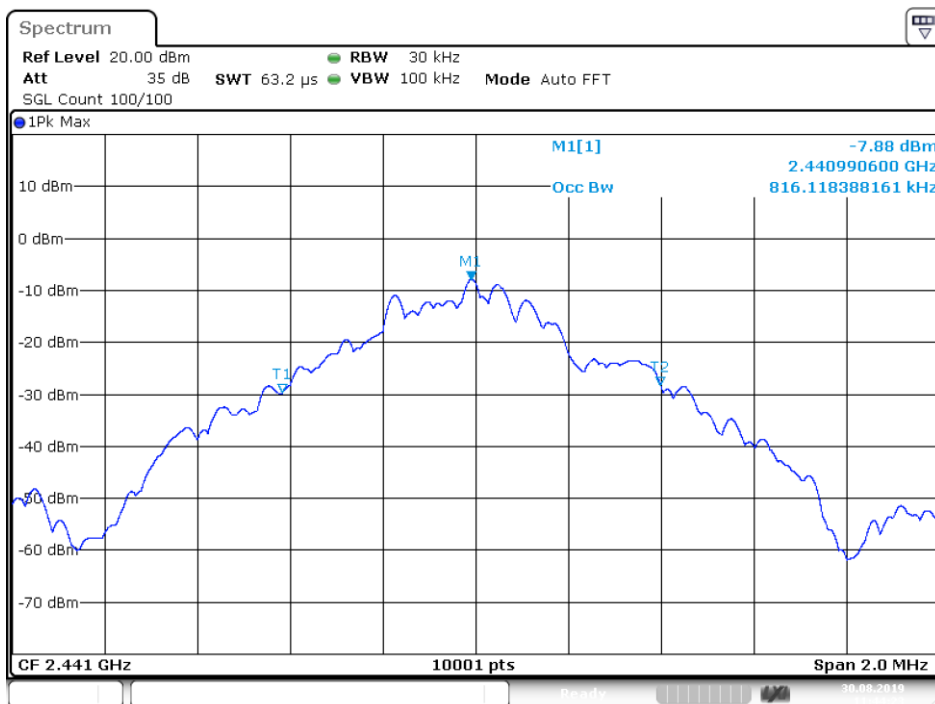

-20 dB BW NVNT 1-DH1 2441MHz Ant1

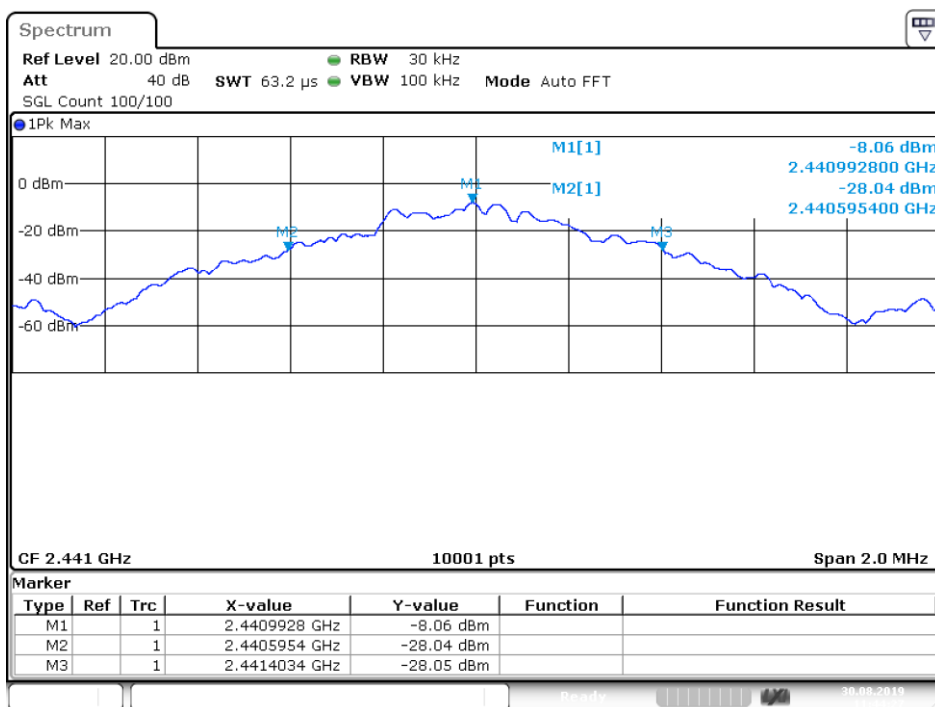

OBW NVNT 1-DH1 2480MHz Ant1

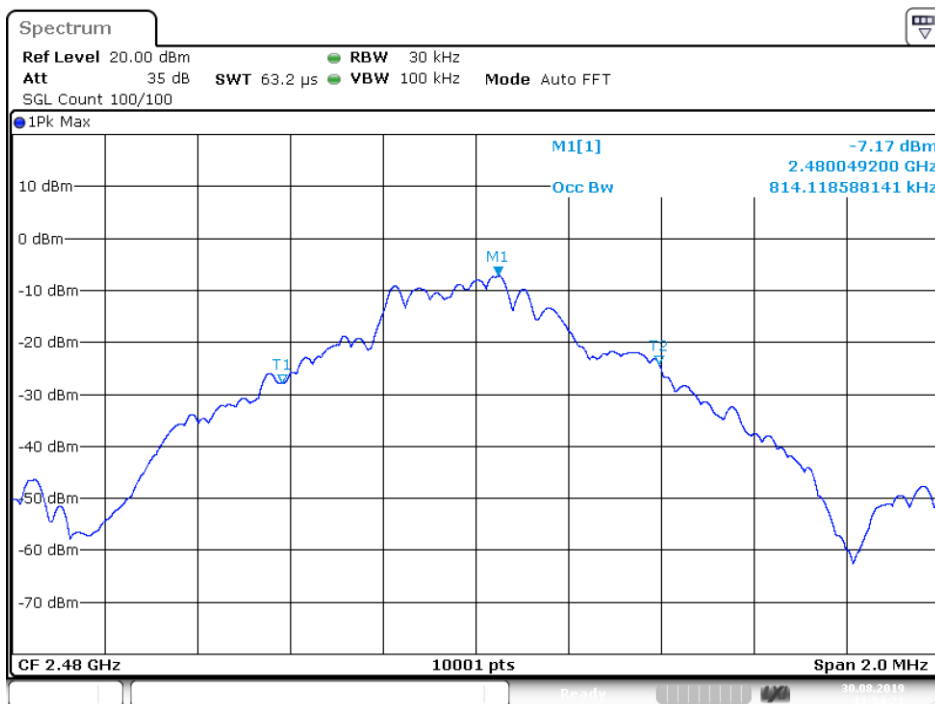

Date: 30.AUG.2019 11:54:20

-20 dB BW NVNT 1-DH1 2480MHz Ant1

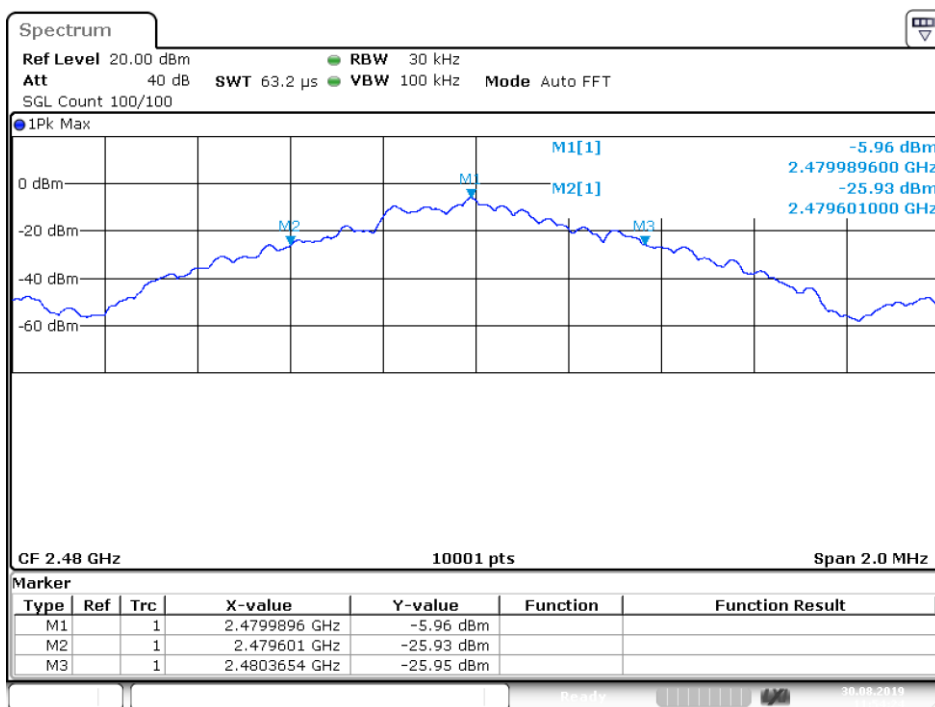

Date: 30.AUG.2019 11:54:24

OBW NVNT 2-DH1 2402MHz Ant1

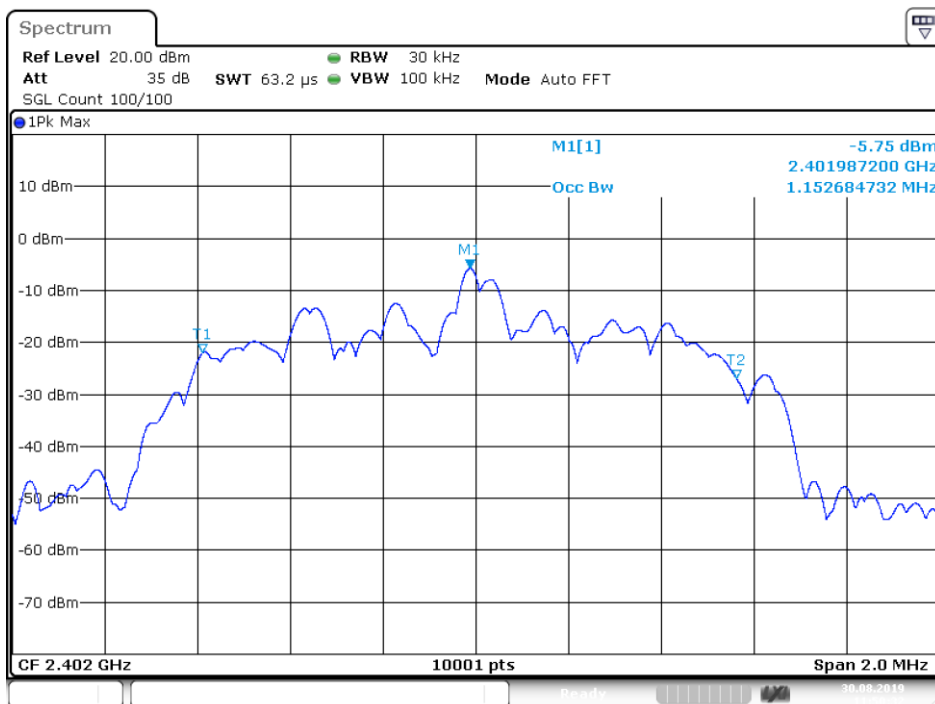

Date: 30.AUG.2019 11:50:32

-20 dB BW NVNT 2-DH1 2402MHz Ant1

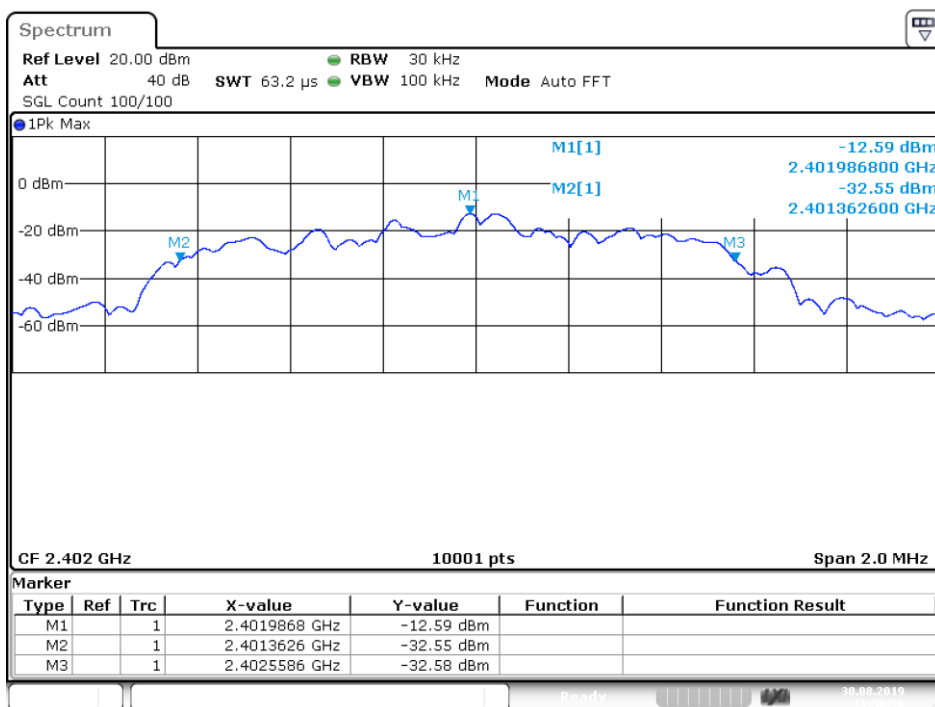

Date: 30.AUG.2019 11:50:35

OBW NVNT 2-DH1 2441MHz Ant1

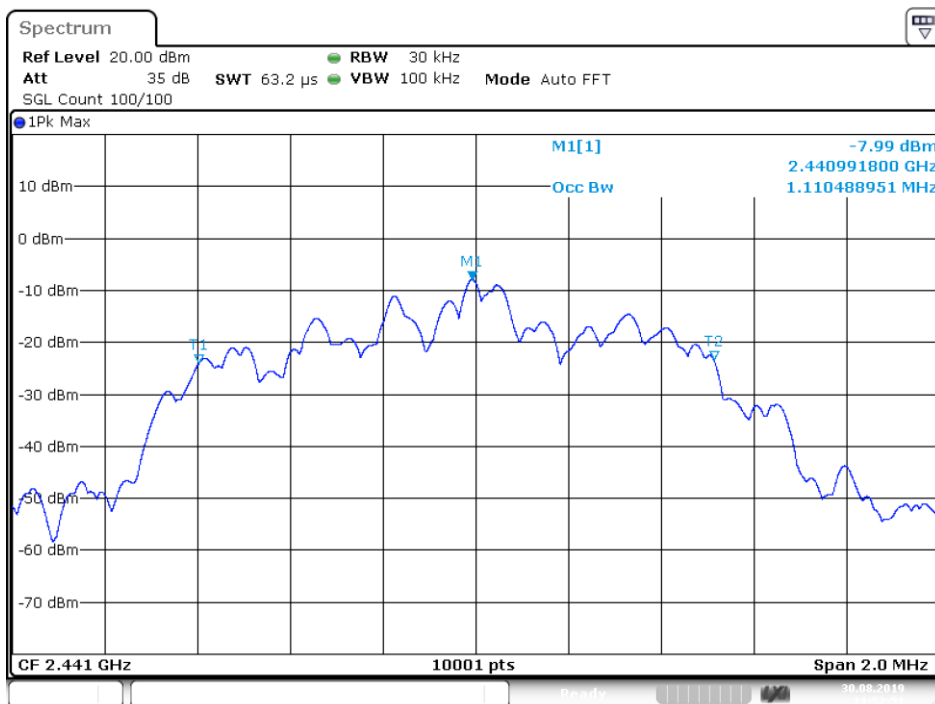

Date: 30.AUG.2019 11:52:51

-20 dB BW NVNT 2-DH1 2441MHz Ant1

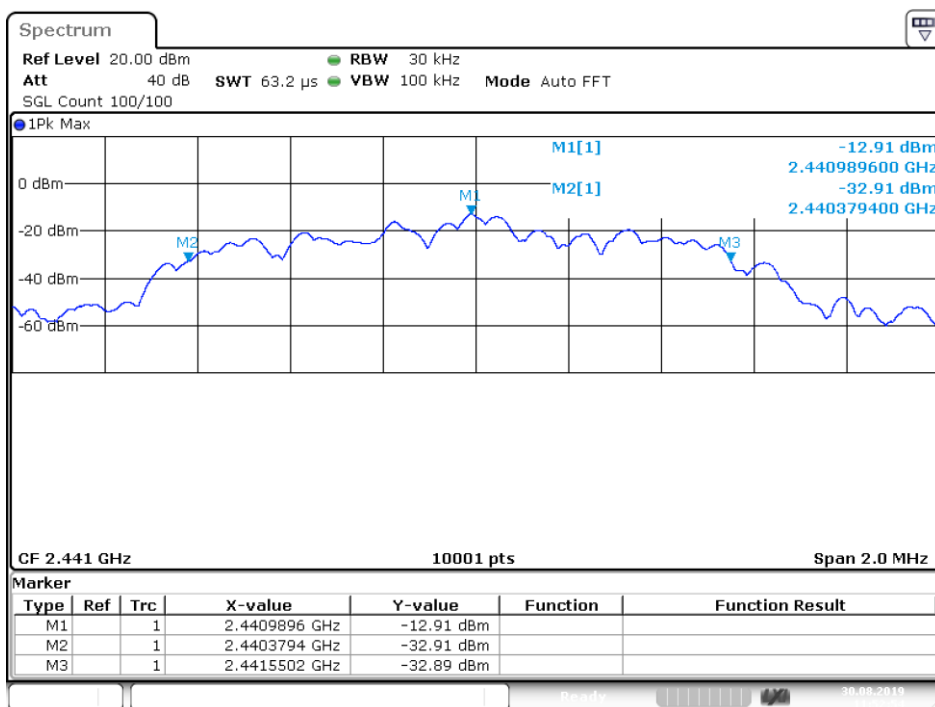

Date: 30.AUG.2019 11:52:54

OBW NVNT 2-DH1 2480MHz Ant1

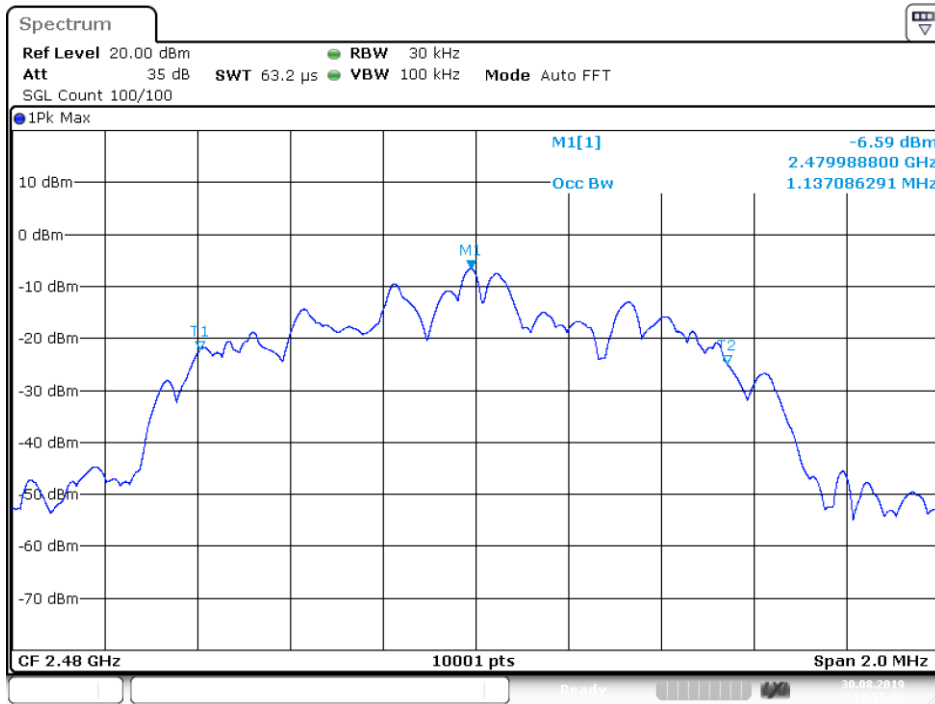

Date: 30.AUG.2019 11:55:20

-20 dB BW NVNT 2-DH1 2480MHz Ant1

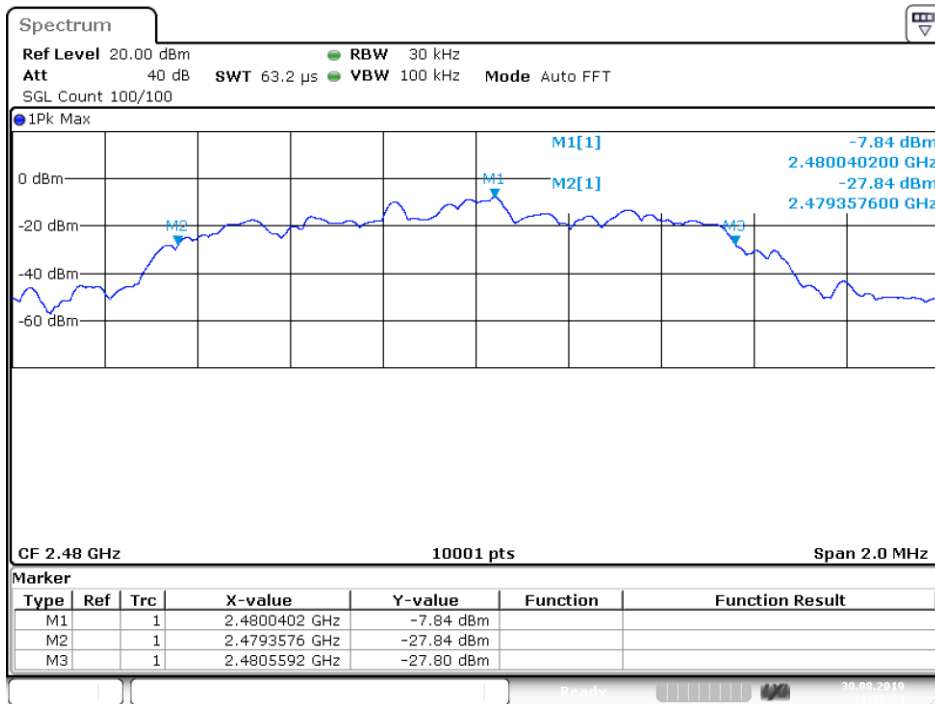

Date: 30.AUG.2019 11:55:24

OBW NVNT 3-DH1 2402MHz Ant1

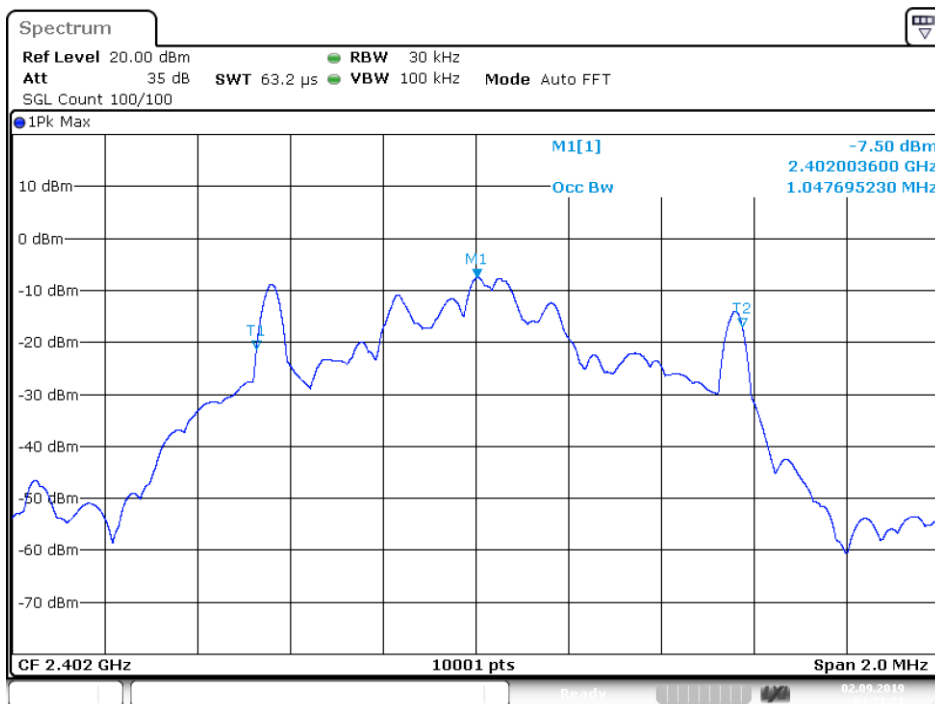

Date: 2.SEP.2019 04:21:21

-20 dB BW NVNT 3-DH1 2402MHz Ant1

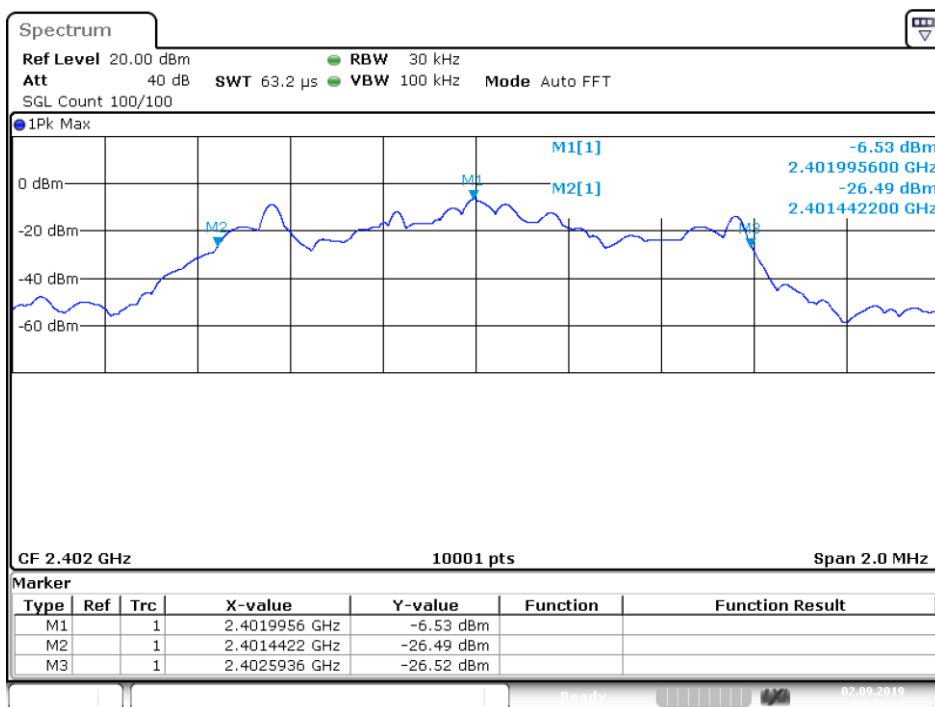

Date: 2.SEP.2019 04:21:24

OBW NVNT 3-DH1 2441MHz Ant1

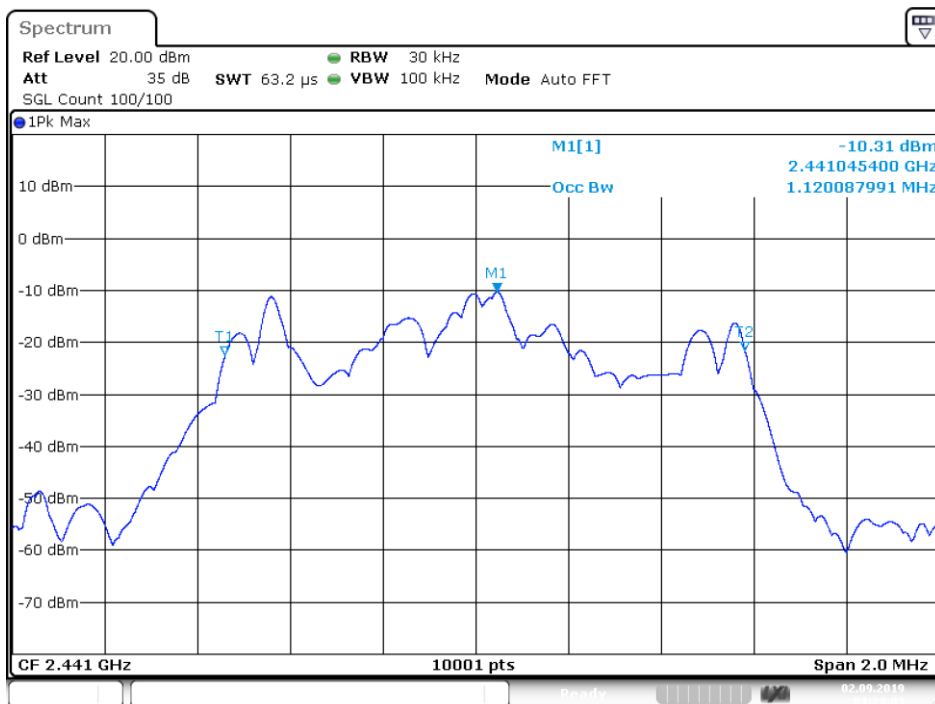

Date: 2.SEP.2019 04:24:03

-20 dB BW NVNT 3-DH1 2441MHz Ant1

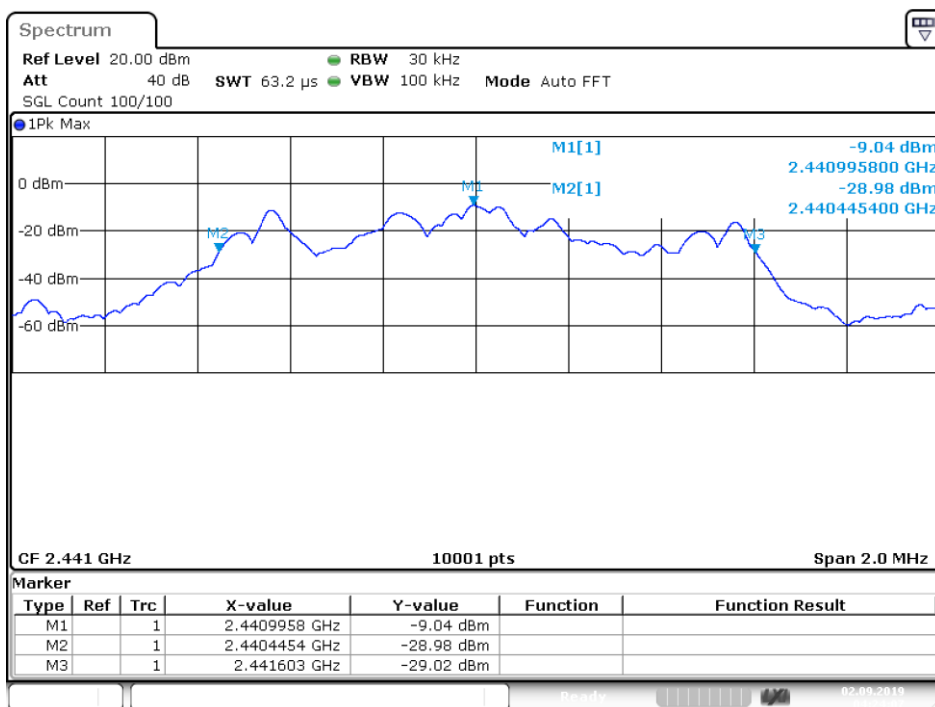

Date: 2.SEP.2019 04:24:07

OBW NVNT 3-DH1 2480MHz Ant1

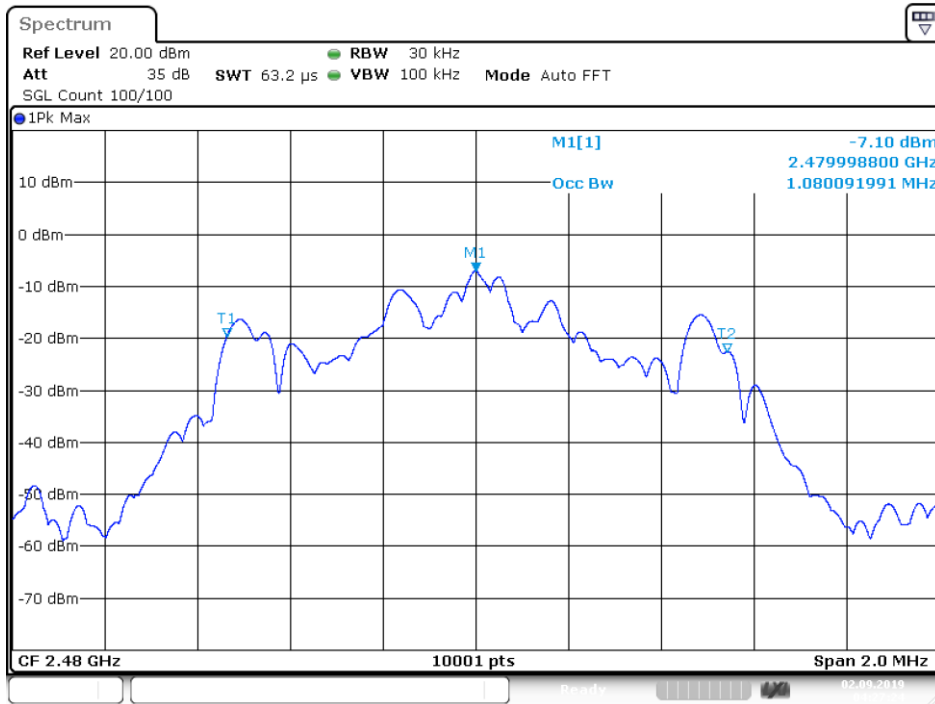

Date: 2.SEP.2019 04:27:24

-20 dB BW NVNT 3-DH1 2480MHz Ant1

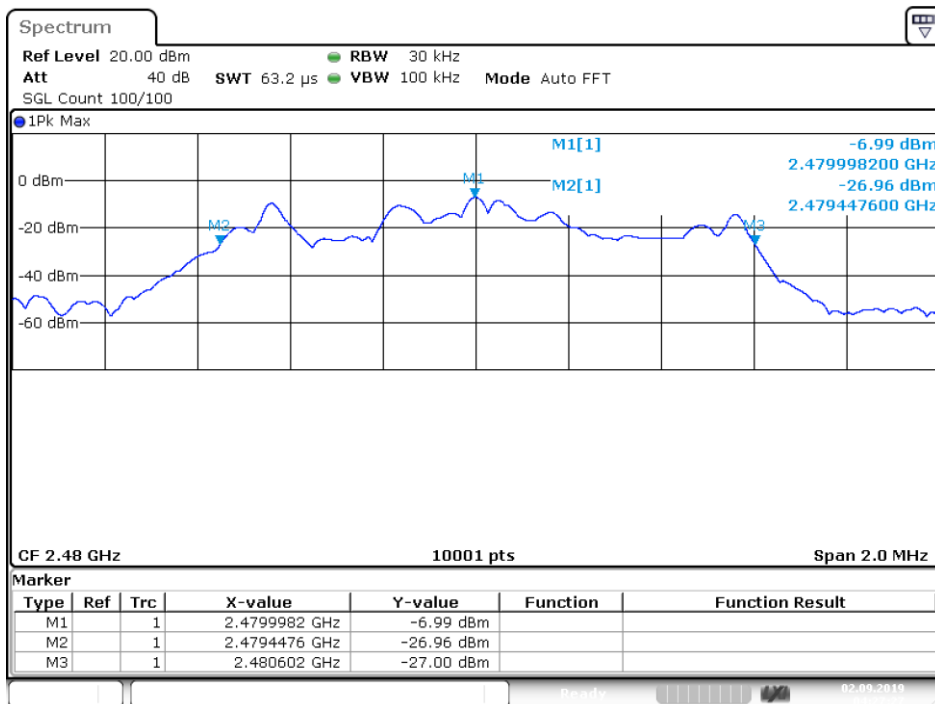

Date: 2.SEP.2019 04:27:27

5. CARRIER FREQUENCY SEPARATION

5.1.Limit

Frequency hopping systems shall have hopping channel carrier frequencies separated by a minimum of 25 kHz or the 20 dB bandwidth of the hopping channel, whichever is greater. Alternatively, frequency hopping systems operating in the 2400-2483.5 MHz band may have hopping channel carrier frequencies that are separated by 25 kHz or two-thirds of the 20 dB bandwidth of the hopping channel, whichever is greater, provided the systems operate with an output power no greater than 125 mW

5.2.Test Procedure

The RF output of EUT was connected to the spectrum analyzer by RF cable and attenuator. The carrier frequency was measured by spectrum analyzer with 30kHz RBW and 100kHz VBW.

5.3.Test Result

Condition	Mode	Hopping Freq1 (MHz)	Hopping Freq2 (MHz)	HFS (MHz)	Limit (MHz)	Verdict
NVNT	1-DH1	2440.84	2442.019	0.812	0.667	Pass
NVNT	2-DH1	2440.84	2442.061	1.313	0.667	Pass
NVNT	3-DH1	2441.005	2442.127	1.004	0.667	Pass

CFS NVNT 1-DH1 2441MHz

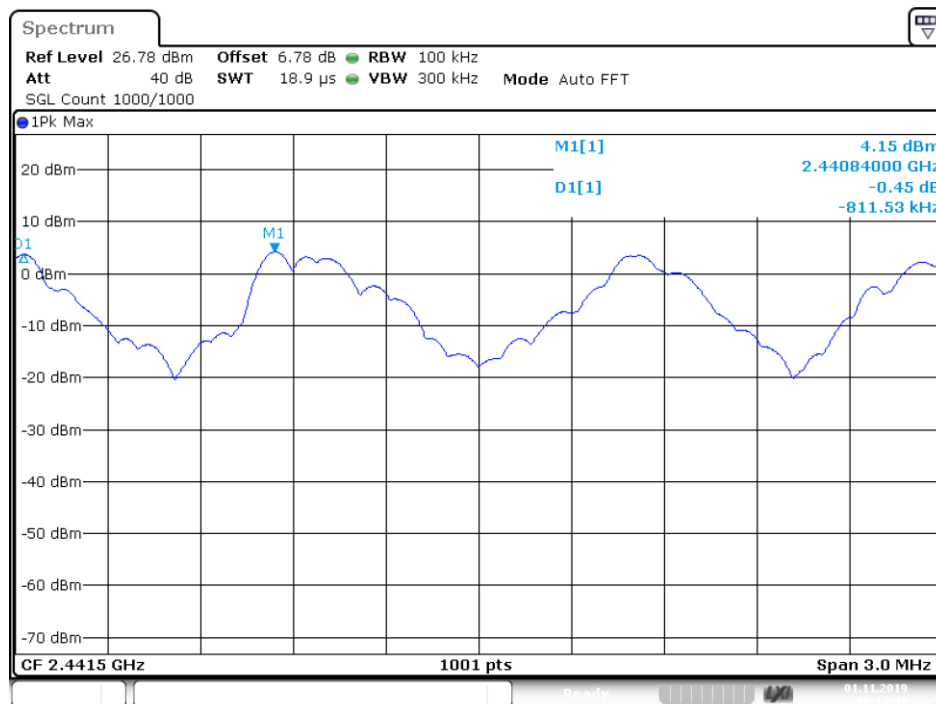

Date: 1.NOV.2019 08:17:41

CFS NVNT 2-DH1 2441MHz

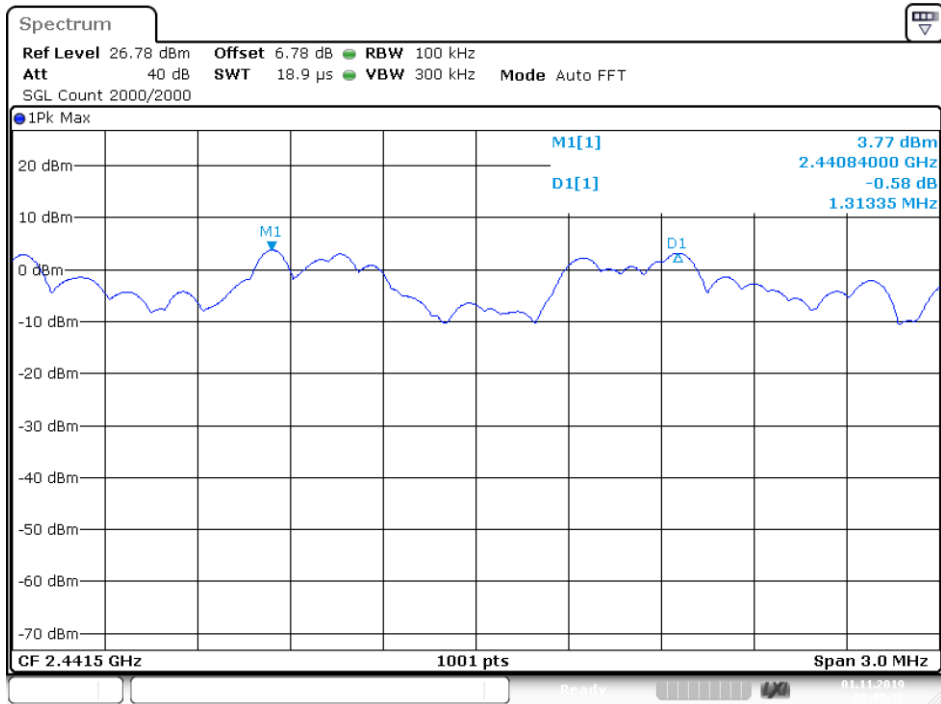

Date: 1.NOV.2019 08:49:16

CFS NVNT 3-DH1 2441MHz

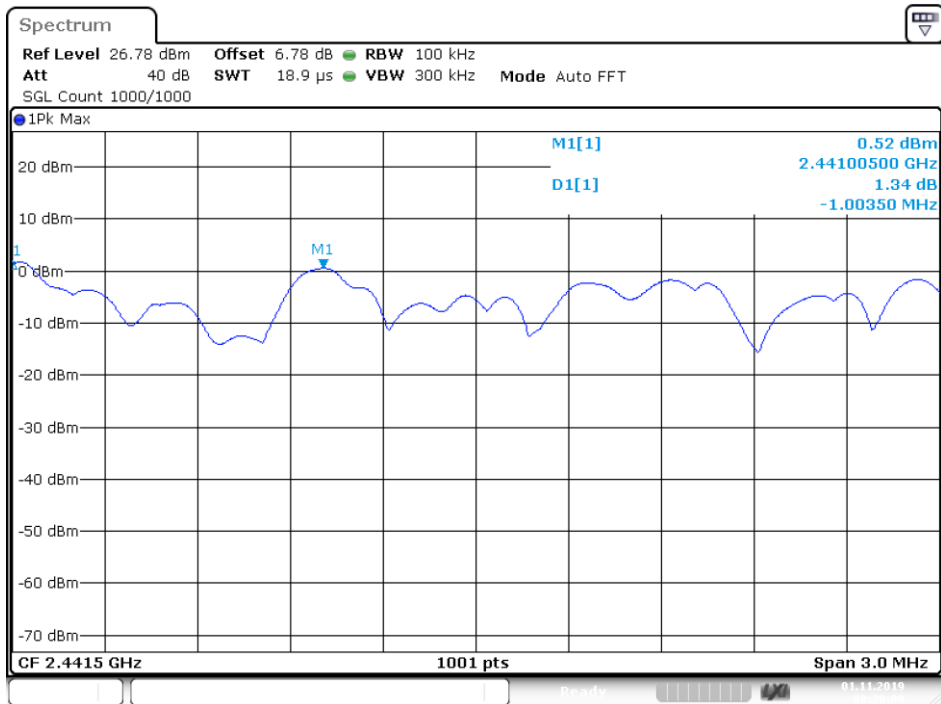

Date: 1.NOV.2019 08:20:08

6. NUMBER OF HOPPING CHANNEL

6.1.Limit

Frequency hopping systems in the 2400-2483.5 MHz band shall use at least 15 channels

6.2.Test Procedure

The RF output of EUT was connected to the spectrum analyzer by RF cable and attenuator. The number of hopping channel was measured by spectrum analyzer with 100kHz RBW and 300KHz VBW.

6.3.Test Result

Condition	Mode	Hopping Number	Limit	Verdict
NVNT	1-DH1	79	15	Pass
NVNT	2-DH1	79	15	Pass
NVNT	3-DH1	79	15	Pass

Hopping No. NVNT 1-DH1 2441MHz

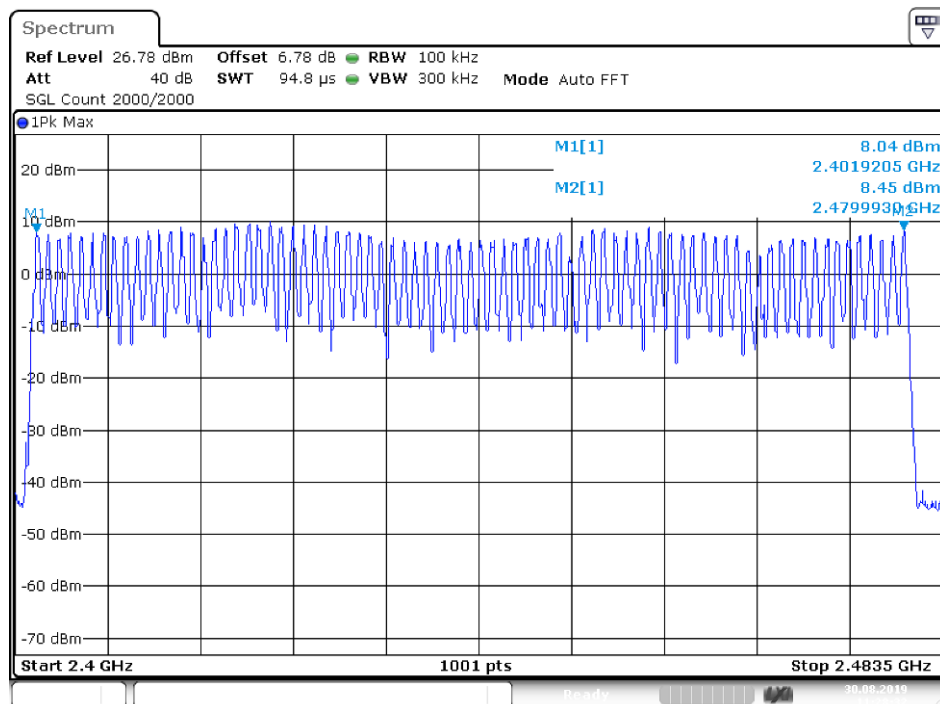

Date: 30.AUG.2019 11:28:31

Hopping No. NVNT 2-DH1 2441MHz

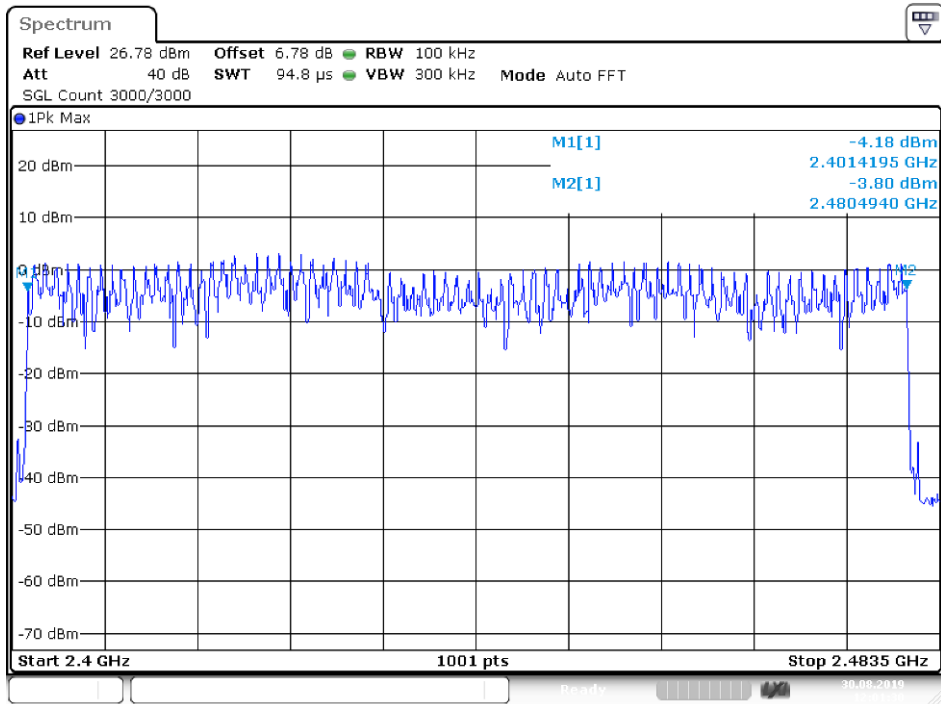

Date: 30.AUG.2019 12:01:30

Hopping No. NVNT 3-DH1 2441MHz

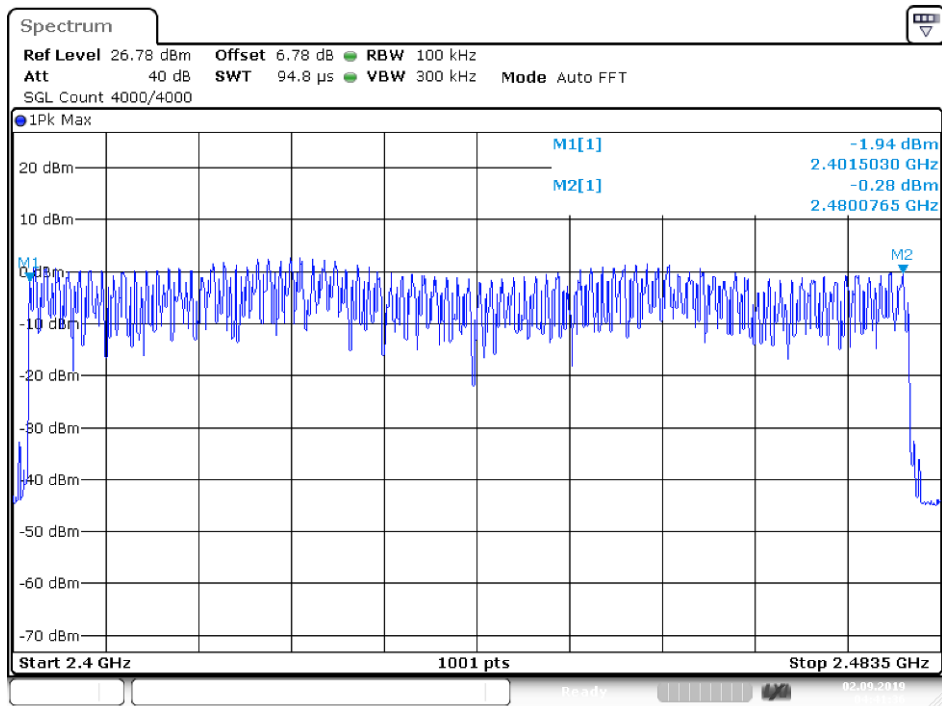

Date: 2.SEP.2019 04:41:36

7. DWELL TIME

7.1. Test limit

Please refer FCC part 15.247 & RSS-247.

Frequency hopping systems operating in the 2400MHz-2483.5 MHz. The average time of occupancy on any frequency shall not greater than 0.4 s within period of 0.4 seconds multiplied by the number of hopping channel employed.

7.2. Test Procedure

7.2.1. Place the EUT on the table and set it in transmitting mode.

7.2.2. Remove the antenna from the EUT and then connect a low loss RF cable from the antenna port to the spectrum analyzer.

7.2.3. Set center frequency of spectrum analyzer = operating frequency.

7.2.4. Set the spectrum analyzer as RBW, VBW=1MHz, Span = 0Hz, Sweep = auto.

7.2.5. Repeat above procedures until all frequency measured were complete.

7.3. Test Result

PASS.

Detailed information please see the following page.

Condition	Mode	Frequency (MHz)	Pulse Time (ms)	Total Dwell Time (ms)	Period Time (ms)	Limit (ms)	Verdict
NVNT	1-DH1	2402	0.376	118.974	31600	400	Pass
NVNT	1-DH1	2441	0.376	118.974	31600	400	Pass
NVNT	1-DH1	2480	0.376	118.974	31600	400	Pass
NVNT	1-DH3	2441	1.632	257.856	31600	400	Pass
NVNT	1-DH5	2441	2.88	273.024	31600	400	Pass
NVNT	2-DH1	2402	0.384	121.249	31600	400	Pass
NVNT	2-DH1	2441	0.383	121.154	31600	400	Pass
NVNT	2-DH1	2480	0.384	121.249	31600	400	Pass
NVNT	2-DH3	2441	1.635	258.33	31600	400	Pass
NVNT	2-DH5	2441	2.883	273.28	31600	400	Pass
NVNT	3-DH1	2402	0.385	121.534	31600	400	Pass
NVNT	3-DH1	2441	0.385	121.534	31600	400	Pass
NVNT	3-DH1	2480	0.385	121.534	31600	400	Pass
NVNT	3-DH3	2441	1.634	258.235	31600	400	Pass
NVNT	3-DH5	2441	2.885	273.536	31600	400	Pass

Dwell NVNT 1-DH1 2402MHz

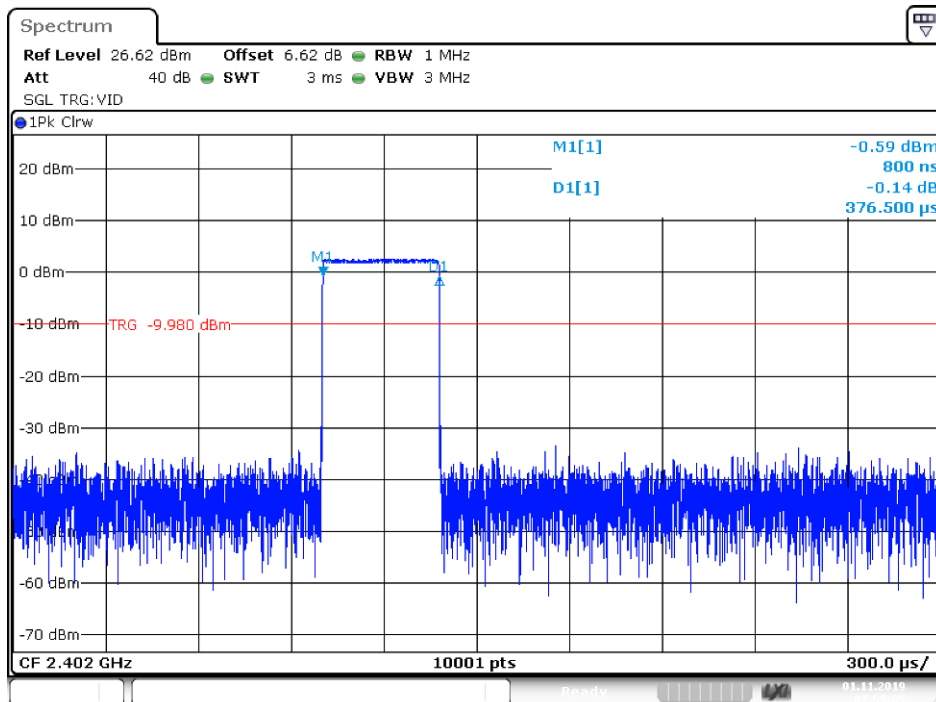

Dwell NVNT 1-DH1 2441MHz

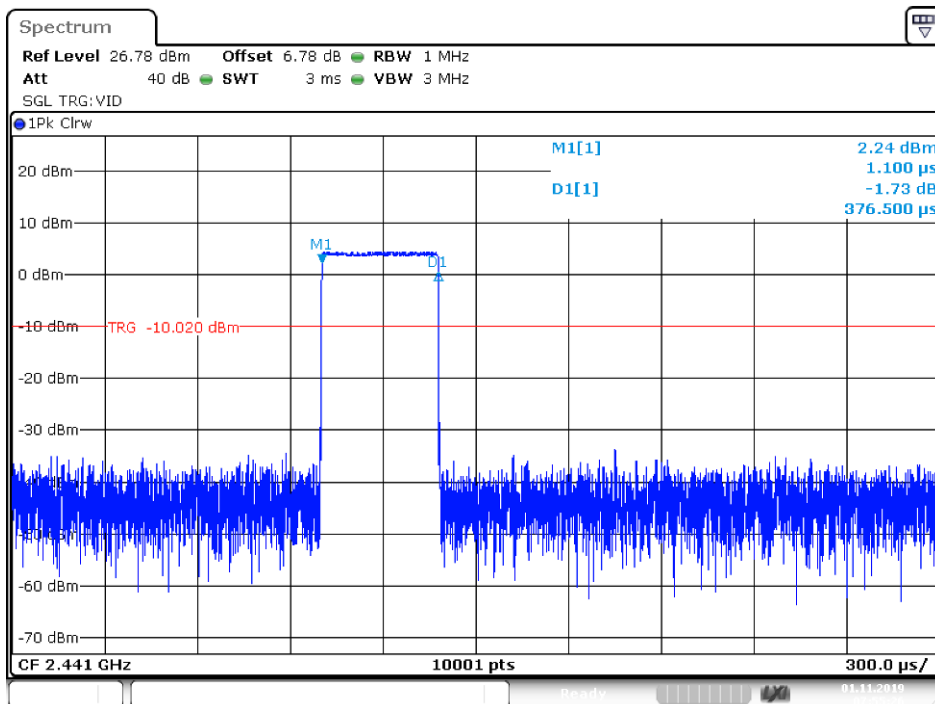

Date: 1.NOV.2019 07:55:26

Dwell NVNT 1-DH1 2480MHz

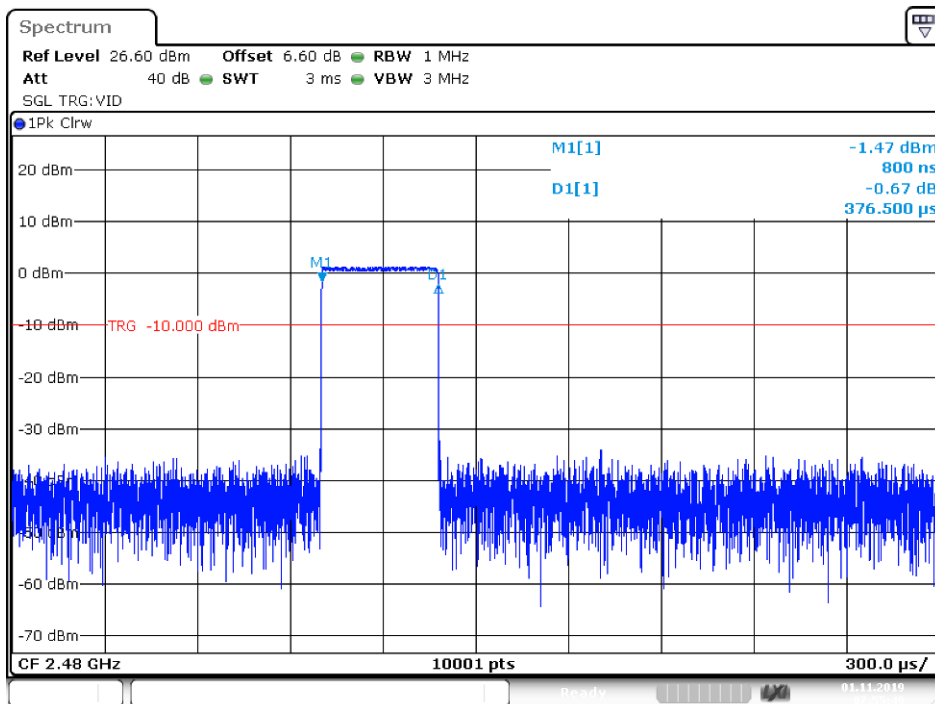

Date: 1.NOV.2019 07:55:49

Dwell NVNT 1-DH3 2441MHz

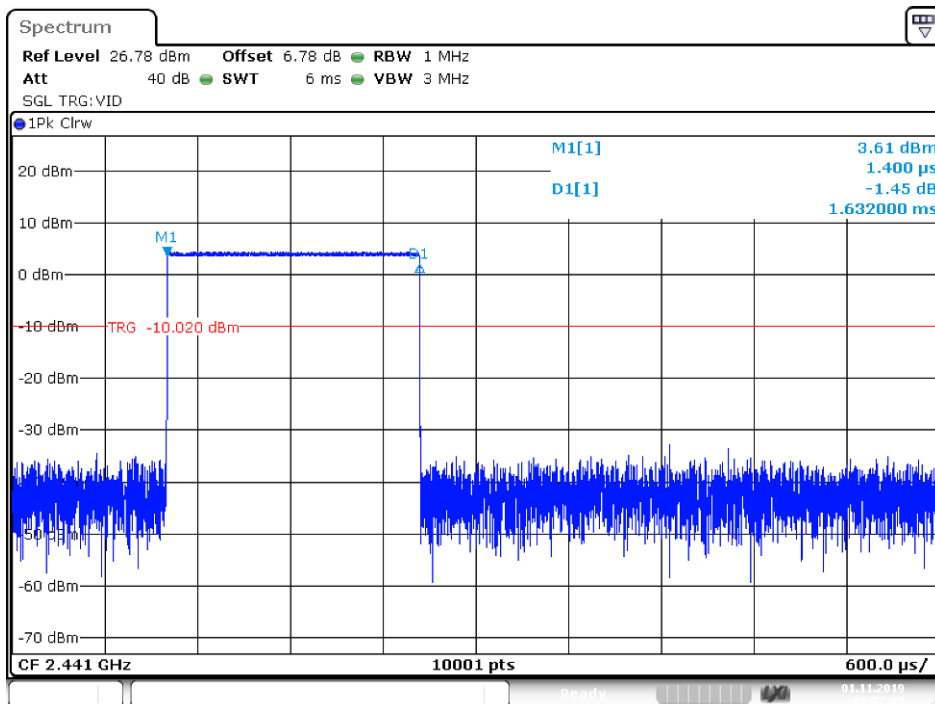

Date: 1.NOV.2019 07:57:07

Dwell NVNT 1-DH5 2441MHz

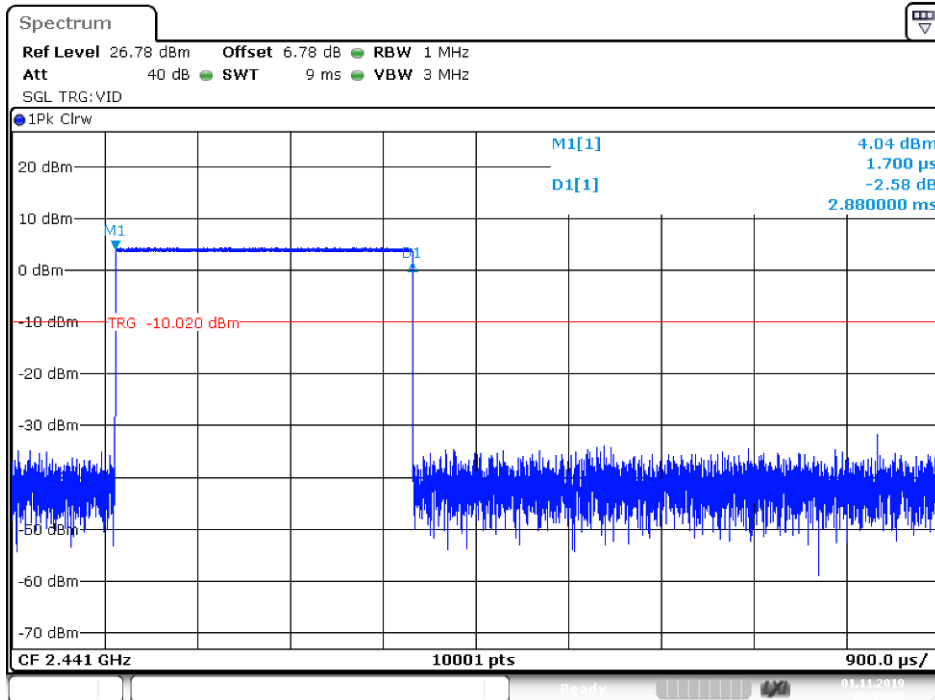

Date: 1.NOV.2019 07:59:05

Dwell NVNT 2-DH1 2402MHz

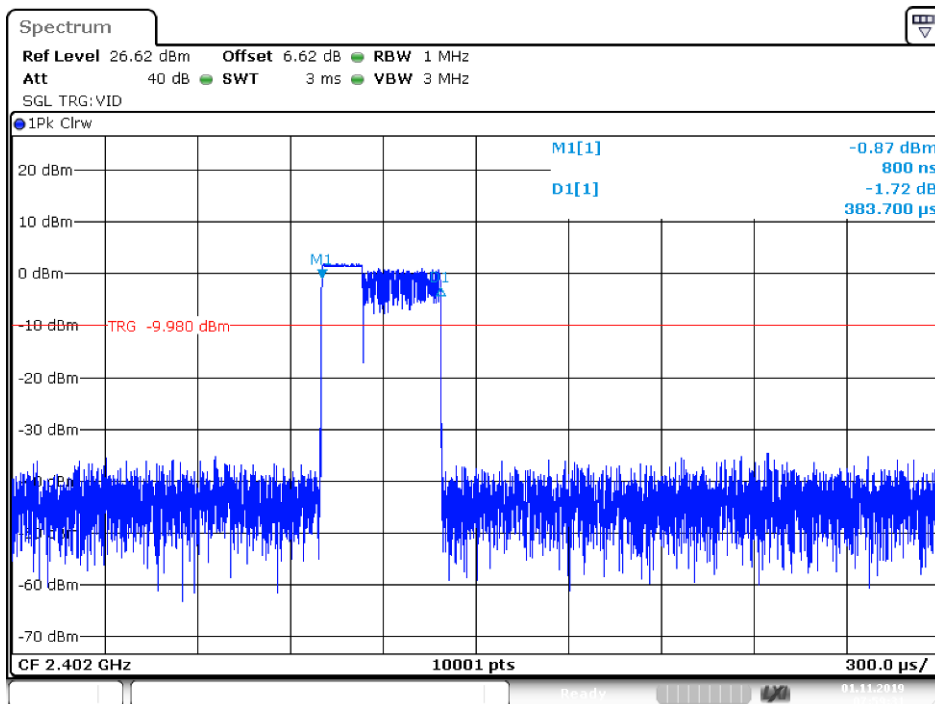

Date: 1.NOV.2019 07:59:31

Dwell NVNT 2-DH1 2441MHz

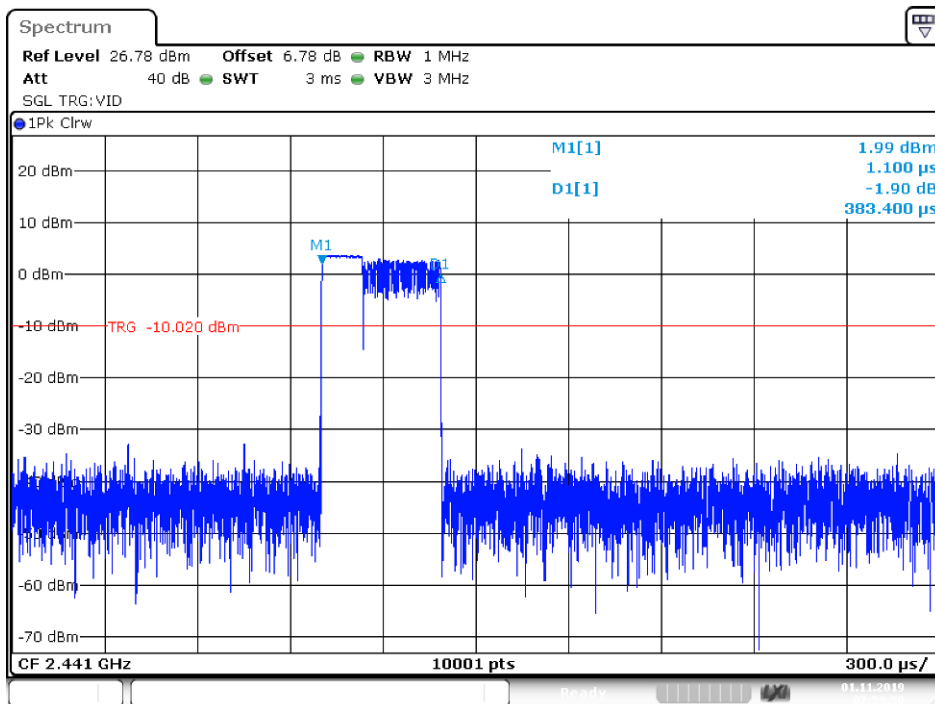

Date: 1.NOV.2019 07:59:50

Dwell NVNT 2-DH1 2480MHz

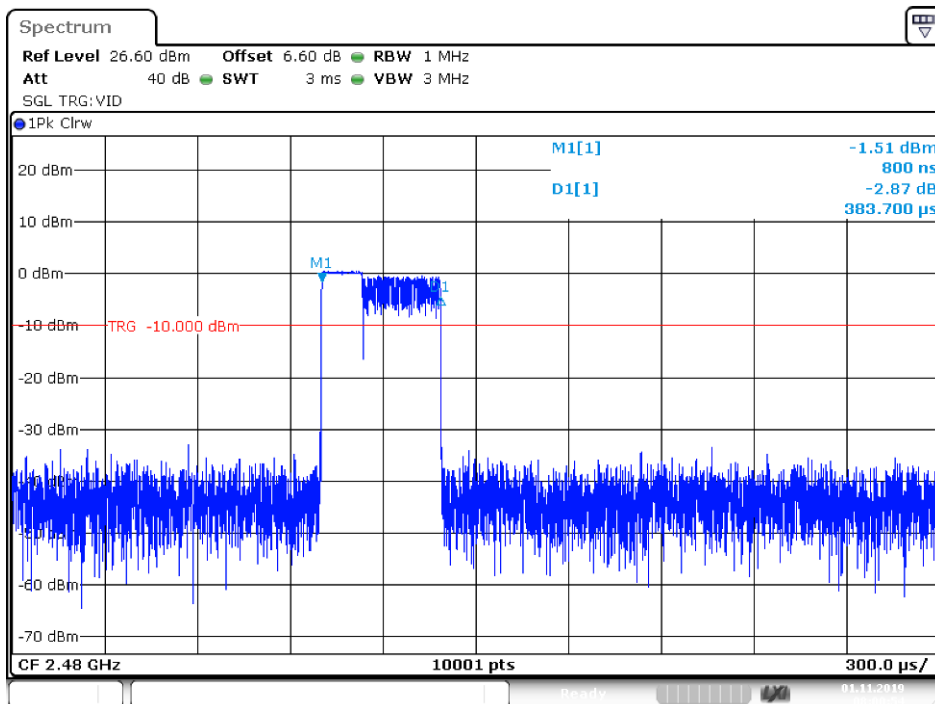

Date: 1.NOV.2019 08:00:54

Dwell NVNT 2-DH3 2441MHz

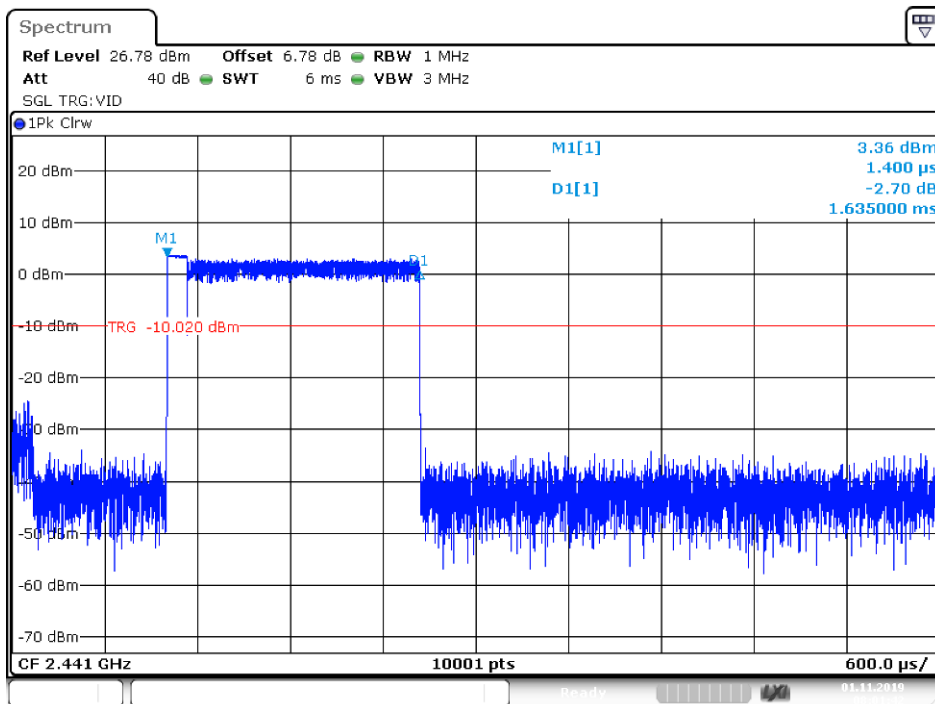

Date: 1.NOV.2019 08:01:42

Dwell NVNT 2-DH5 2441MHz

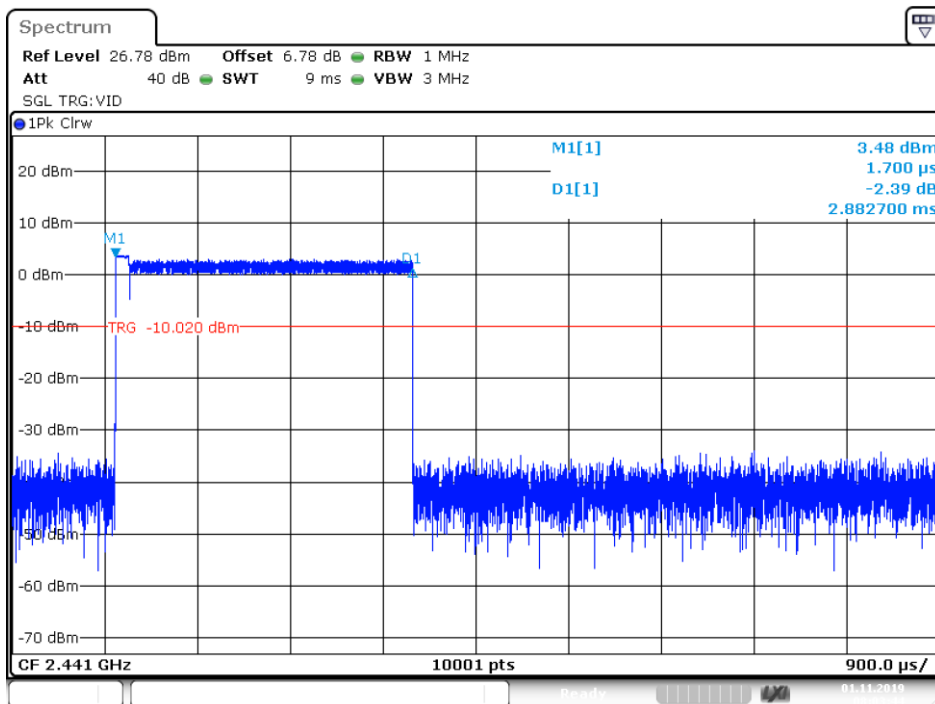

Date: 1.NOV.2019 08:03:44

Dwell NVNT 3-DH1 2402MHz

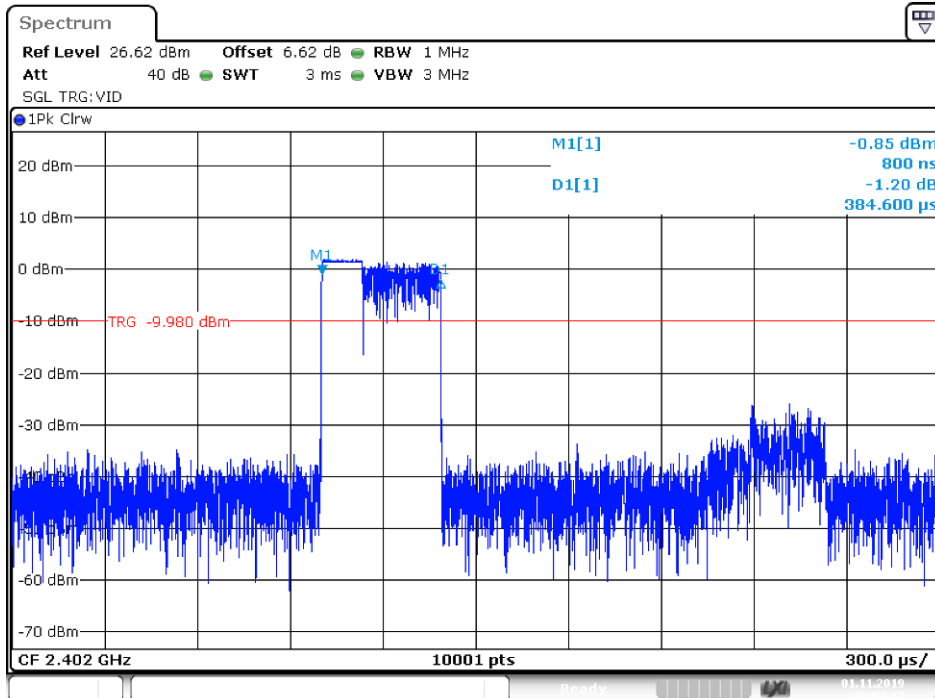

Date: 1.NOV.2019 08:04:17

Dwell NVNT 3-DH1 2441MHz

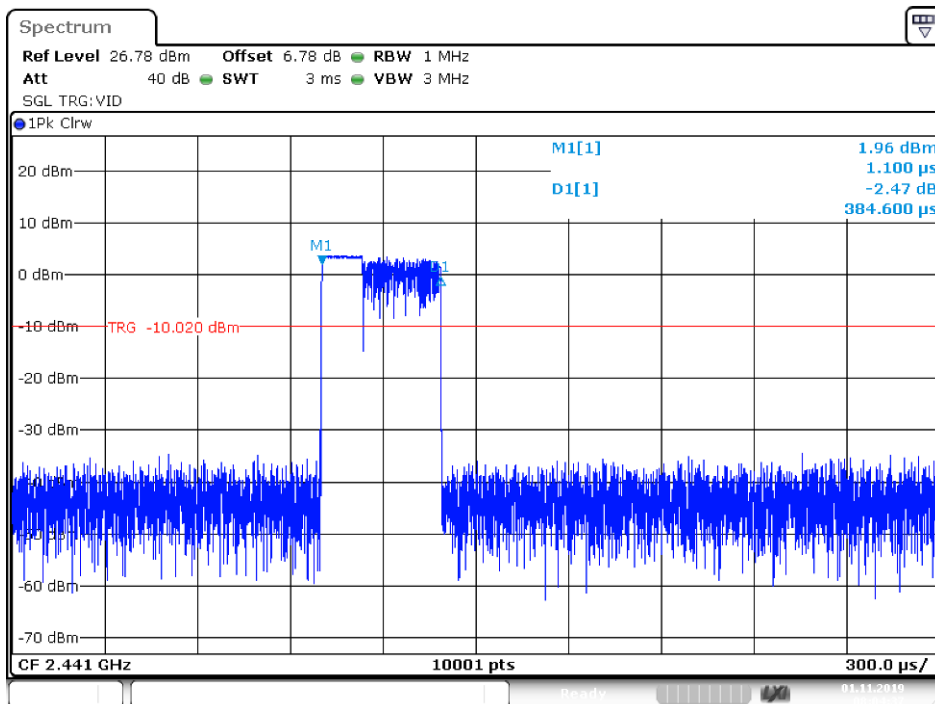

Date: 1.NOV.2019 08:04:37

Dwell NVNT 3-DH1 2480MHz

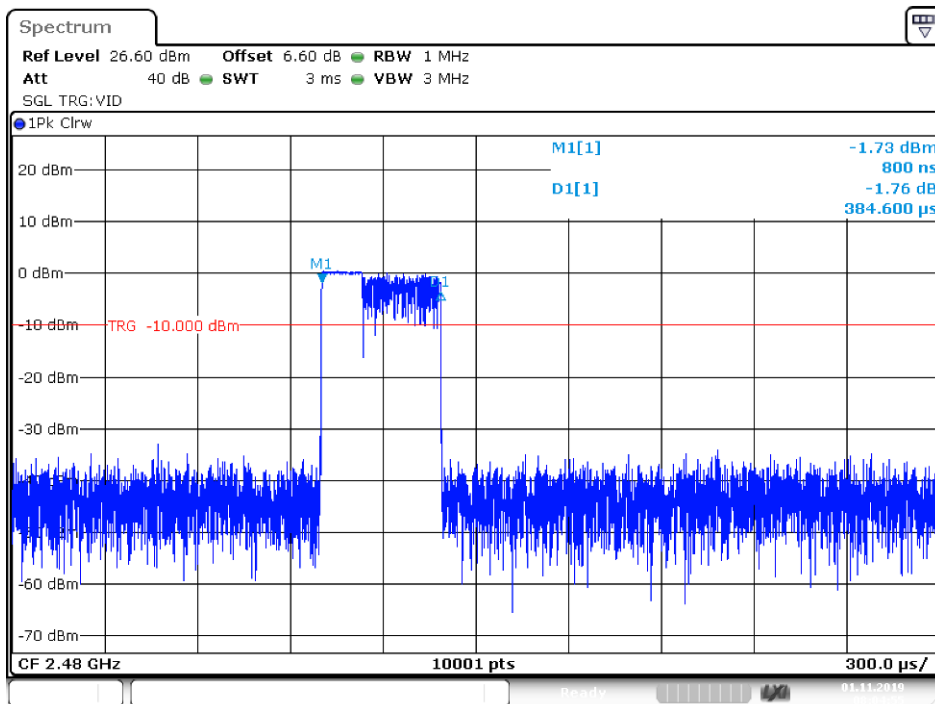

Date: 1.NOV.2019 08:04:54

Dwell NVNT 3-DH3 2441MHz

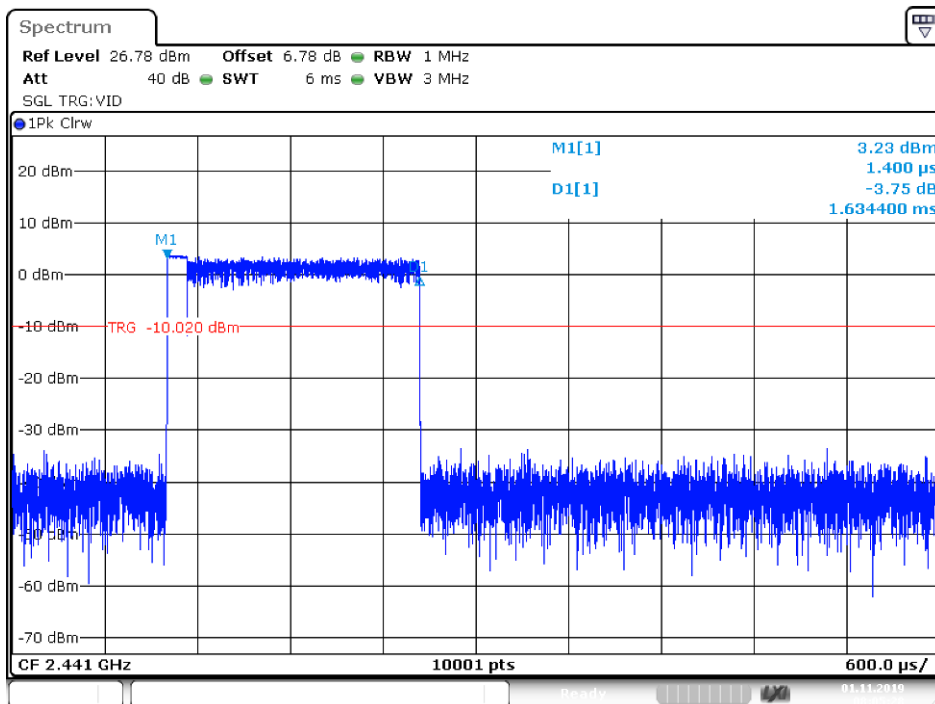

Date: 1.NOV.2019 08:05:28

Dwell NVNT 3-DH5 2441MHz

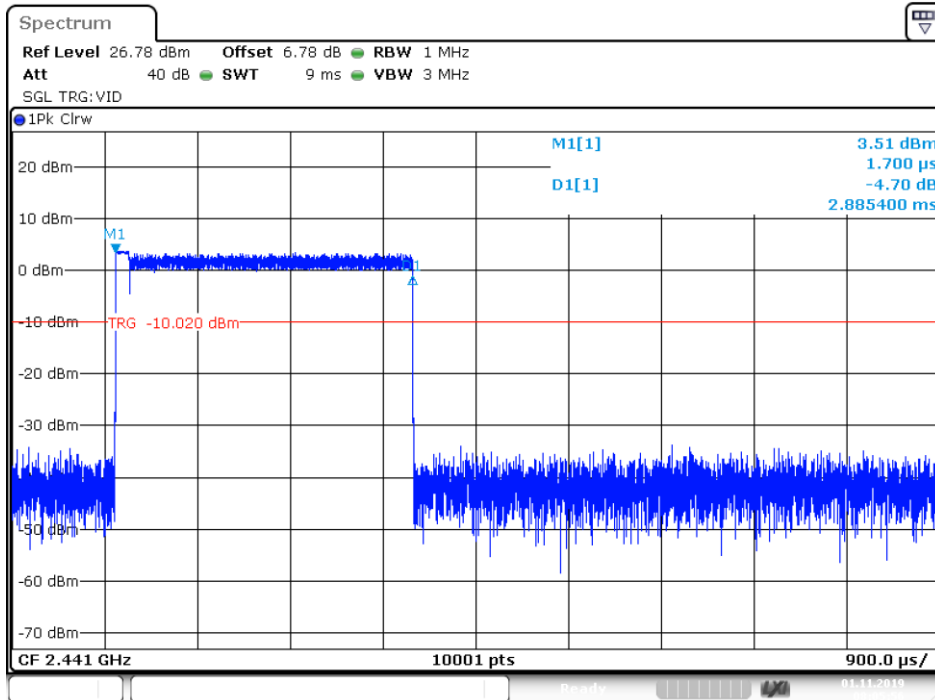

Date: 1.NOV.2019 08:05:55

8. RADIATED EMISSIONS

8.1.Limit

All the emissions appearing within 15.205 restricted frequency bands shall not exceed the limits shown in 15.209, all the other emissions shall be at least 20dB below the fundamental emissions, or comply with 15.209 limits.

15.205 Restricted frequency band

MHz	MHz	MHz	GHz
0.090 - 0.110	16.42 - 16.423	399.9 - 410	4.5 - 5.15
¹ 0.495 - 0.505	16.69475 - 16.69525	608 - 614	5.35 - 5.46
2.1735 - 2.1905	16.80425 - 16.80475	960 - 1240	7.25 - 7.75
4.125 - 4.128	25.5 - 25.67	1300 - 1427	8.025 - 8.5
4.17725 - 4.17775	37.5 - 38.25	1435 - 1626.5	9.0 - 9.2
4.20725 - 4.20775	73 - 74.6	1645.5 - 1646.5	9.3 - 9.5
6.215 - 6.218	74.8 - 75.2	1660 - 1710	10.6 - 12.7
6.26775 - 6.26825	108 - 121.94	1718.8 - 1722.2	13.25 - 13.4
6.31175 - 6.31225	123 - 138	2200 - 2300	14.47 - 14.5
8.291 - 8.294	149.9 - 150.05	2310 - 2390	15.35 - 16.2
8.362 - 8.366	156.52475 - 156.52525	2483.5 - 2500	17.7 - 21.4
8.37625 - 8.38675	156.7 - 156.9	2690 - 2900	22.01 - 23.12
8.41425 - 8.41475	162.0125 - 167.17	3260 - 3267	23.6 - 24.0
12.29 - 12.293	167.72 - 173.2	3332 - 3339	31.2 - 31.8
12.51975 - 12.52025	240 - 285	3345.8 - 3358	36.43 - 36.5
12.57675 - 12.57725	322 - 335.4	3600 - 4400	(²)

RSS-GEN Restricted frequency band

Table 7 – Restricted frequency bands ^{Note 1}

MHz	MHz	GHz
0.090 - 0.110	149.9 - 150.05	9.0 - 9.2
0.495 - 0.505	156.52475 - 156.52525	9.3 - 9.5
2.1735 - 2.1905	156.7 - 156.9	10.6 - 12.7
3.020 - 3.026	162.0125 - 167.17	13.25 - 13.4
4.125 - 4.128	167.72 - 173.2	14.47 - 14.5
4.17725 - 4.17775	240 – 285	15.35 - 16.2
4.20725 - 4.20775	322 - 335.4	17.7 - 21.4

5.677 - 5.683	399.9 - 410	22.01 - 23.12
6.215 - 6.218	608 - 614	23.6 - 24.0
6.26775 - 6.26825	960 - 1427	31.2 - 31.8
6.31175 - 6.31225	1435 - 1626.5	36.43 - 36.5
8.291 - 8.294	1645.5 - 1646.5	Above 38.6
8.362 - 8.366	1660 - 1710	
8.37625 - 8.38675	1718.8 - 1722.2	
8.41425 - 8.41475	2200 - 2300	
12.29 - 12.293	2310 - 2390	
12.51975 - 12.52025	2483.5 - 2500	
12.57675 - 12.57725	2655 - 2900	
13.36 - 13.41	3260 – 3267	
16.42 - 16.423	3332 - 3339	
16.69475 - 16.69525	3345.8 - 3358	
16.80425 - 16.80475	3500 - 4400	
25.5 - 25.67	4500 - 5150	
37.5 - 38.25	5350 - 5460	
73 - 74.6	7250 - 7750	
74.8 - 75.2	8025 – 8500	
108 – 138		

Note 1: Certain frequency bands listed in table 7 and in bands above 38.6 GHz are designated for licence-exempt applications. These frequency bands and the requirements that apply to related devices are set out in the 200 and 300 series of RSSs.

15.209 Limit

FREQUENCY MHz	DISTANCE Meters	FIELD STRENGTHS LIMIT	
		$\mu\text{V}/\text{m}$	$\text{dB}(\mu\text{V})/\text{m}$
0.009-0.490	300	2400/F(KHz)	/
0.490-1.705	30	24000/F(KHz)	/
1.705-30	30	30	29.5
30 ~ 88	3	100	40.0
88 ~ 216	3	150	43.5
216 ~ 960	3	200	46.0
960 ~ 1000	3	500	54.0
Above 1000	3	74.0 $\text{dB}(\mu\text{V})/\text{m}$ (Peak) 54.0 $\text{dB}(\mu\text{V})/\text{m}$ (Average)	

Note: The peak limit is 20 dB higher than the average limit

Table 5 – General field strength limits at frequencies above 30 MHz

Frequency (MHz)	Field strength ($\mu\text{V}/\text{m}$ at 3 m)
30 – 88	100
88 – 216	150
216 – 960	200
Above 960	500

Table 6 – General field strength limits at frequencies below 30 MHz

Frequency	Magnetic field strength (H-Field) ($\mu\text{A}/\text{m}$)	Measurement distance (m)
9 - 490 kHz ^{Note 1}	6.37/F (F in kHz)	300
490 - 1705 kHz	63.7/F (F in kHz)	30
1.705 - 30 MHz	0.08	30

Note 1: The emission limits for the ranges 9-90 kHz and 110-490 kHz are based on measurements employing a linear average detector.

8.2. Block Diagram of Test setup

8.2.1 In 3m Anechoic Chamber Test Setup Diagram for below 30MHz

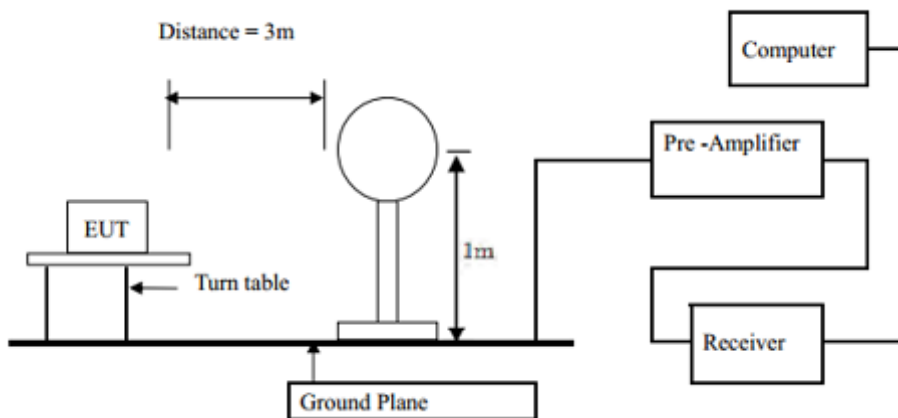

8.2.1 In 3m Anechoic Chamber Test Setup Diagram for below 1GHz

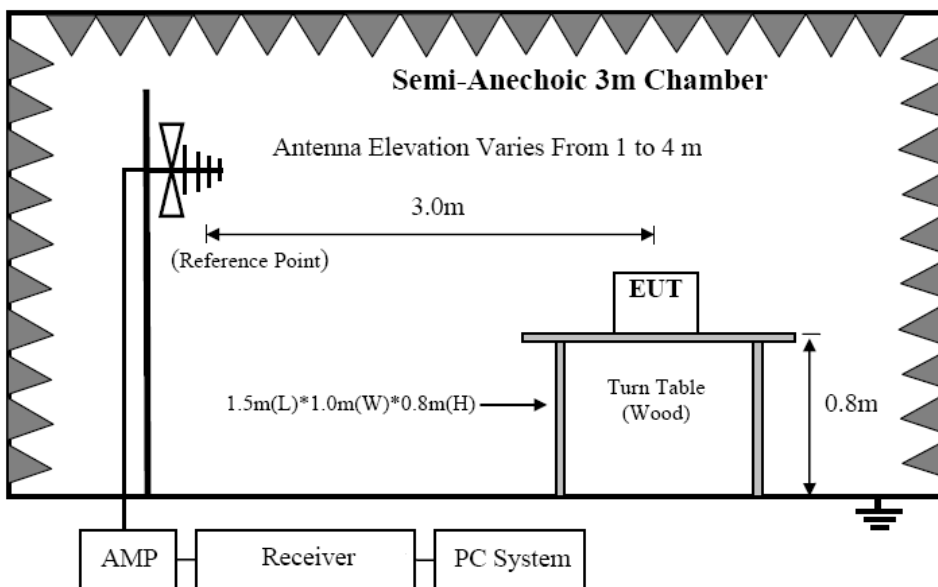

8.2.2 In 3m Anechoic Chamber Test Setup Diagram for frequency above 1GHz

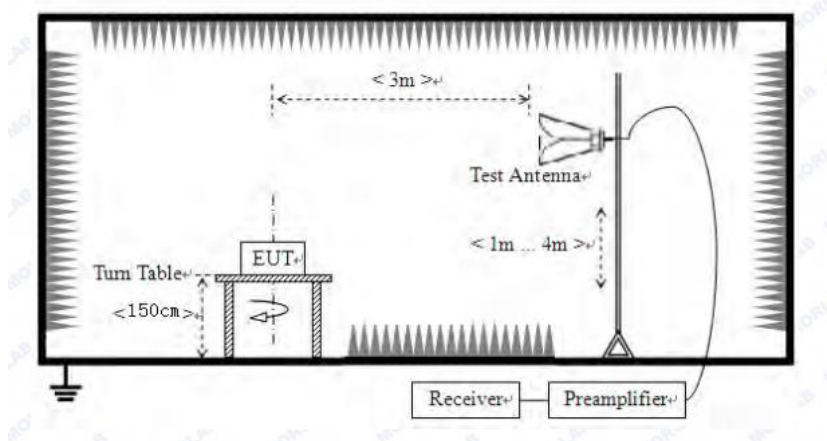

Note: For harmonic emissions test a appropriate high pass filter was inserted in the input port of AMP.

8.3. Test Procedure

- (1) EUT was placed on a non-metallic table, 80 cm above the ground plane inside a semi-anechoic chamber.
- (2) Setup EUT and simulator
- (3) Test antenna was located 3m from the EUT on an adjustable mast. Below pre-scan procedure was first performed in order to find prominent radiated emissions.
 - (a) Change work frequency or channel of device if practicable.
 - (b) Change modulation type of device if practicable.
 - (c) Rotated EUT though three orthogonal axes to determine the attitude of EUT arrangement produces highest emissions
- (4) Spectrum frequency from 9KHz to 25GHz (tenth harmonic of fundamental frequency) was investigated
- (5) For final emissions measurements at each frequency of interest, the EUT were rotated and the antenna height was varied between 1m and 4m in order to maximize the emission. Measurements in both horizontal and vertical polarities were made and the data was recorded. In order to find the maximum emission, the relative positions of equipments and all of the interface cables were changed according to ANSI C63.10 :2013on Radiated Emission test.
- (6) For emissions above 1GHz, both Peak and Average level were measured with Spectrum Analyzer, and the RBW is set at 1MHz, VBW is set at 3MHz for Peak measure; RBW is set at 1MHz, VBW is set at 10Hz for Average measure.

8.4. Test Result

We have scanned from 9kHz to the 10th harmonic of the EUT's highest frequency. Detailed information please see the following page.

From 9KHz to 30MHz: Conclusion: PASS

Note: The amplitude of spurious emissions which are attenuated by more than 20dB below the permissible value has no need to be reported.

From 30MHz to 1000MHz: Conclusion: PASS

Vertical:

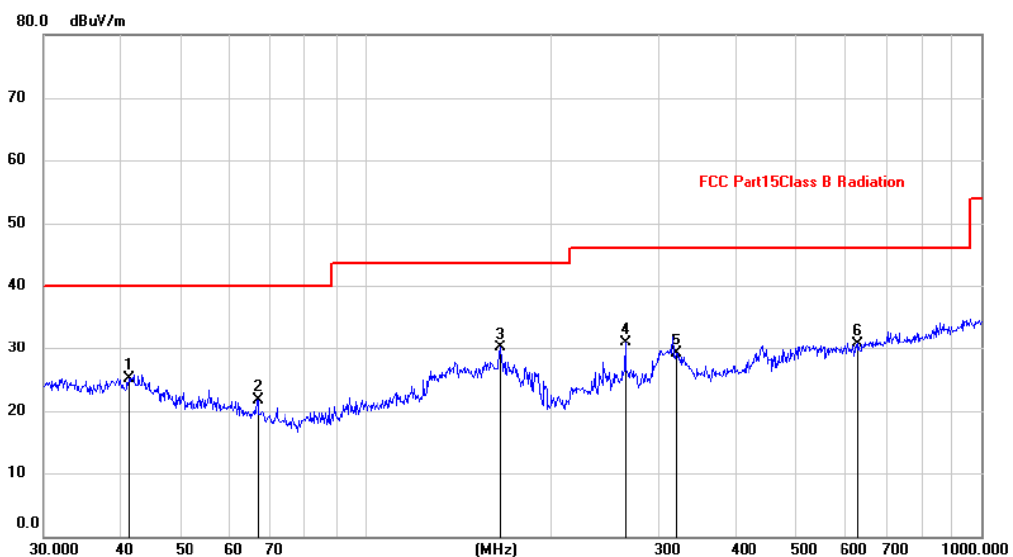

No.	Mk.	Freq.	Reading Level	Correct Factor	Measurement	Limit	Margin	Antenna Height	Table Degree
		MHz	dBuV	dB	dBuV/m	dBuV/m	dB	cm	degree
1		41.2764	10.84	14.34	25.18	40.00	-14.82	peak	
2		66.7325	9.84	11.88	21.72	40.00	-18.28	peak	
3	*	165.4866	15.57	14.51	30.08	43.50	-13.42	peak	
4		263.8190	17.84	13.09	30.93	46.00	-15.07	peak	
5		319.9370	14.51	14.63	29.14	46.00	-16.86	peak	
6		631.6884	9.93	20.87	30.80	46.00	-15.20	peak	

Note: 1. *:Maximum data; x:Over limit; !:over margin.

2.Measurement=Reading Level+Correct Factor; Correct Factor=Antenna Factor+Cable Loss.

Horizontal:

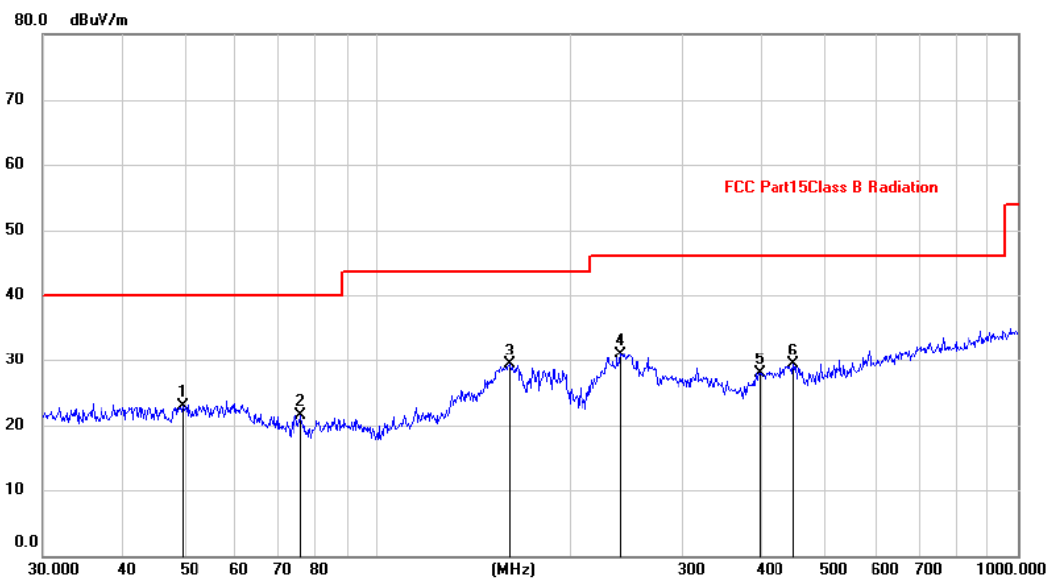

No.	Mk.	Freq. MHz	Reading Level dBuV	Correct Factor dB	Measure- ment dBuV/m	Limit dBuV/m	Margin dB	Antenna Height cm	Table Degree	Comment
1		49.5328	8.81	14.04	22.85	40.00	-17.15			peak
2		75.9770	10.92	10.50	21.42	40.00	-18.58			peak
3	*	160.9088	14.29	14.95	29.24	43.50	-14.26			peak
4		240.8300	18.43	12.57	31.00	46.00	-15.00			peak
5		394.8543	11.82	16.16	27.98	46.00	-18.02			peak
6		446.4141	11.78	17.48	29.26	46.00	-16.74			peak

Note:1. *:Maximum data; x:Over limit; !:over margin.

2.Measurement=Reading Level+Correct Factor; Correct Factor=Antenna Factor+Cable Loss.

Remark: All modes have been tested, and only worst data of GFSK mode, Channel 2441MHz (AC 120V/ 60Hz) was listed in this report.

From 1G-25GHz

Test Mode: GFSK TX Low									
Freq (MHz)	Read Level (dBuV/m)	Polar (H/V)	Antenna Factor (dB/m)	Cable loss(dB)	Amp Factor (dB)	Result (dBuV/m)	Limit (dBuV/m)	Margin (dB)	Remark
4804	44.67	V	33.95	10.18	34.26	54.54	74	19.46	PK
4804	35.77	V	33.95	10.18	34.26	45.64	54	8.36	AV
7206	/	/	/	/	/	/	/	/	/
9608	/	/	/	/	/	/	/	/	/
4804	44.17	H	33.95	10.18	34.26	54.04	74	19.96	PK
4804	34.28	H	33.95	10.18	34.26	44.15	54	9.85	AV
7206	/	/	/	/	/	/	/	/	/
9608	/	/	/	/	/	/	/	/	/
Test Mode: GFSK TX Mid									
4882	45.84	V	33.93	10.2	34.29	55.68	74	18.32	PK
4882	35.28	V	33.93	10.2	34.29	45.12	54	8.88	AV
7323	/	/	/	/	/	/	/	/	/
9764	/	/	/	/	/	/	/	/	/
4882	42.98	H	33.93	10.2	34.29	52.82	74	21.18	PK
4882	32.62	H	33.93	10.2	34.29	42.46	54	11.54	AV
7323	/	/	/	/	/	/	/	/	/
9764	/	/	/	/	/	/	/	/	/
Test Mode: GFSK TX High									
4960	42.93	V	33.98	10.22	34.25	52.88	74	21.12	PK
4960	36.07	V	33.98	10.22	34.25	46.02	54	7.98	AV
7440	/	/	/	/	/	/	/	/	/
9920	/	/	/	/	/	/	/	/	/
4960	45.59	H	33.98	10.22	34.25	55.54	74	18.46	PK
4960	34.73	H	33.98	10.22	34.25	44.68	54	9.32	AV
7440	/	/	/	/	/	/	/	/	/
9920	/	/	/	/	/	/	/	/	/
Note:									
1, Result = Read level + Antenna factor + cable loss-Amp factor									
2, All the other emissions not reported were too low to read and deemed to comply with FCC limit.									

From 1G-25GHz

Test Mode: $\pi/4$ DQPSK TX Low									
Freq (MHz)	Read Level (dBuV/m)	Polar (H/V)	Antenna Factor (dB/m)	Cable loss(dB)	Amp Factor (dB)	Result (dBuV/m)	Limit (dBuV/m)	Margin (dB)	Remark
4804	42.04	V	33.95	10.18	34.26	51.91	74	22.09	PK
4804	36.39	V	33.95	10.18	34.26	46.26	54	7.74	AV
7206	/	/	/	/	/	/	/	/	/
9608	/	/	/	/	/	/	/	/	/
4804	44.02	H	33.95	10.18	34.26	53.89	74	20.11	PK
4804	34.25	H	33.95	10.18	34.26	44.12	54	9.88	AV
7206	/	/	/	/	/	/	/	/	/
9608	/	/	/	/	/	/	/	/	/
Test Mode: $\pi/4$ DQPSK TX Mid									
4882	43.84	V	33.93	10.2	34.29	53.68	74	20.32	PK
4882	33.14	V	33.93	10.2	34.29	42.98	54	11.02	AV
7323	/	/	/	/	/	/	/	/	/
9764	/	/	/	/	/	/	/	/	/
4882	44.77	H	33.93	10.2	34.29	54.61	74	19.39	PK
4882	33.35	H	33.93	10.2	34.29	43.19	54	10.81	AV
7323	/	/	/	/	/	/	/	/	/
9764	/	/	/	/	/	/	/	/	/
Test Mode: $\pi/4$ DQPSK TX High									
4960	44.75	V	33.98	10.22	34.25	54.70	74	19.30	PK
4960	35.21	V	33.98	10.22	34.25	45.16	54	8.84	AV
7440	/	/	/	/	/	/	/	/	/
9920	/	/	/	/	/	/	/	/	/
4960	45.91	H	33.98	10.22	34.25	55.86	74	18.14	PK
4960	35.50	H	33.98	10.22	34.25	45.45	54	8.55	AV
7440	/	/	/	/	/	/	/	/	/
9920	/	/	/	/	/	/	/	/	/
Note:									
1, Result = Read level + Antenna factor + cable loss-Amp factor									
2, All the other emissions not reported were too low to read and deemed to comply with FCC limit.									

From 1G-25GHz

Test Mode: 8- DQPSK TX Low									
Freq (MHz)	Read Level (dBuV/m)	Polar (H/V)	Antenna Factor (dB/m)	Cable loss(dB)	Amp Factor (dB)	Result (dBuV/m)	Limit (dBuV/m)	Margin (dB)	Remark
4804	41.93	V	33.95	10.18	34.26	51.80	74	22.20	PK
4804	35.98	V	33.95	10.18	34.26	45.85	54	8.15	AV
7206	/	/	/	/	/	/	/	/	/
9608	/	/	/	/	/	/	/	/	/
4804	43.23	H	33.95	10.18	34.26	53.10	74	20.90	PK
4804	33.02	H	33.95	10.18	34.26	42.89	54	11.11	AV
7206	/	/	/	/	/	/	/	/	/
9608	/	/	/	/	/	/	/	/	/
Test Mode: 8- DQPSK TX Mid									
4882	43.94	V	33.93	10.2	34.29	53.78	74	20.22	PK
4882	35.95	V	33.93	10.2	34.29	45.79	54	8.21	AV
7323	/	/	/	/	/	/	/	/	/
9764	/	/	/	/	/	/	/	/	/
4882	43.59	H	33.93	10.2	34.29	53.43	74	20.57	PK
4882	33.18	H	33.93	10.2	34.29	43.02	54	10.98	AV
7323	/	/	/	/	/	/	/	/	/
9764	/	/	/	/	/	/	/	/	/
Test Mode: 8- DQPSK TX High									
4960	43.21	V	33.98	10.22	34.25	53.16	74	20.84	PK
4960	36.35	V	33.98	10.22	34.25	46.30	54	7.70	AV
7440	/	/	/	/	/	/	/	/	/
9920	/	/	/	/	/	/	/	/	/
4960	47.38	H	33.98	10.22	34.25	57.33	74	16.67	PK
4960	35.77	H	33.98	10.22	34.25	45.72	54	8.28	AV
7440	/	/	/	/	/	/	/	/	/
9920	/	/	/	/	/	/	/	/	/
Note:									
1, Result = Read level + Antenna factor + cable loss-Amp factor									
2, All the other emissions not reported were too low to read and deemed to comply with FCC limit.									

9. BAND EDGE COMPLIANCE

9.1. Block Diagram of Test Setup

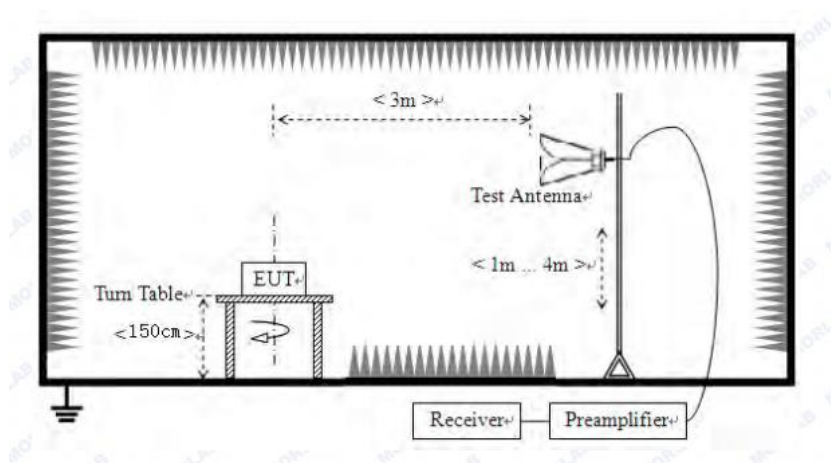

9.2. Limit

All the lower and upper band-edges emissions appearing within restricted frequency bands shall not exceed the limits shown in FCC part 15.209 and RSS-GEN, all the other emissions outside operation shall be at least 20dB below the fundamental emissions, or comply with FCC part 15.209 and RSS-GEN limits.

9.3. Test Procedure

Refer to ANSI C 63.10, Clause 6.10.

All restriction band and non- restriction band have been tested, only worse case is reported.

9.4. Test Result

PASS. (See below detailed test data)

Radiated Method:

Polarization: Vertical

Test Mode: GFSK-Low

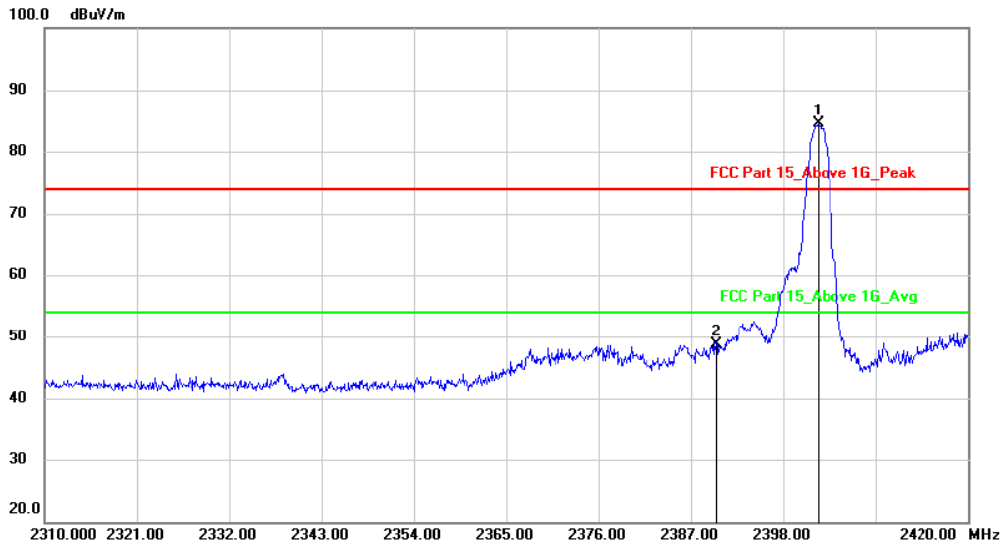

No.	Mk.	Freq.	Reading Level	Correct Factor	Measurement	Limit	Margin	Antenna Height	Table Degree	
		MHz	dBuV	dB	dBuV/m	dBuV/m	dB	cm	degree	Comment
1	*	2402.180	88.01	-3.41	84.60	74.00	10.60	peak		
2		2390.000	52.01	-3.40	48.61	74.00	-25.39	peak		

hopping-off

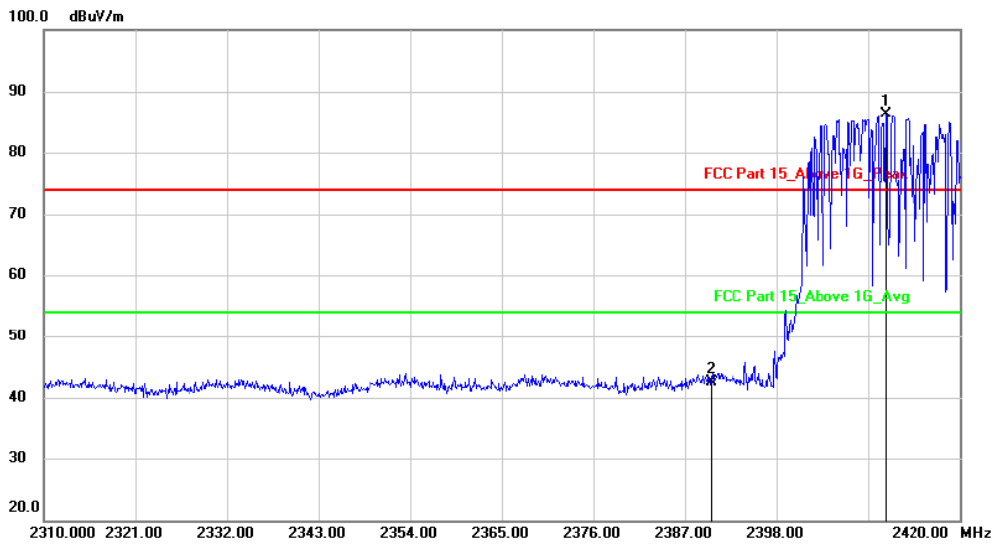

No.	Mk.	Freq.	Reading Level	Correct Factor	Measurement	Limit	Margin	Antenna Height	Table Degree	
		MHz	dBuV	dB	dBuV/m	dBuV/m	dB	cm	degree	Comment
1	*	2411.090	89.74	-3.40	86.34	74.00	12.34	peak		
2		2390.000	45.97	-3.40	42.57	74.00	-31.43	peak		

hopping-on

Polarization: Horizontal:

Test Mode: GFSK-Low

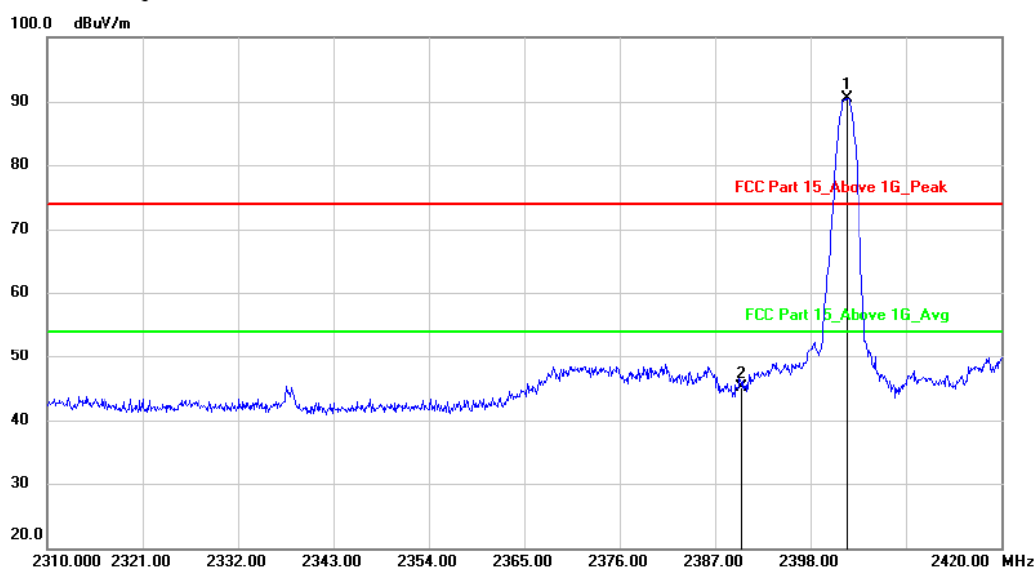

No.	Mk.	Freq. MHz	Reading Level dBuV	Correct Factor dB	Measure- ment dBuV/m	Limit dBuV/m	Margin dB	Detector	Antenna Height cm	Table Degree	Comment
1	*	2402.180	93.93	-3.41	90.52	74.00	16.52	peak			
2		2390.000	48.45	-3.40	45.05	74.00	-28.95	peak			

hopping-off

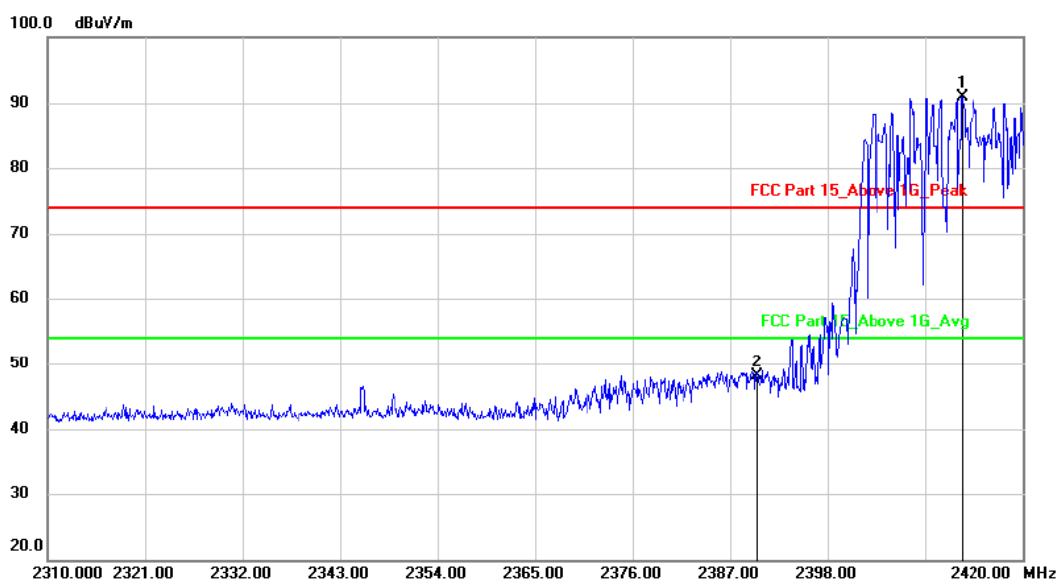

No.	Mk.	Freq. MHz	Reading Level dBuV	Correct Factor dB	Measure- ment dBuV/m	Limit dBuV/m	Margin dB	Detector	Antenna Height cm	Table Degree	Comment
1	*	2413.180	94.32	-3.41	90.91	74.00	16.91	peak			
2		2390.000	51.46	-3.40	48.06	74.00	-25.94	peak			

hopping-on

Polarization: Vertical

Test Mode: GFSK-High

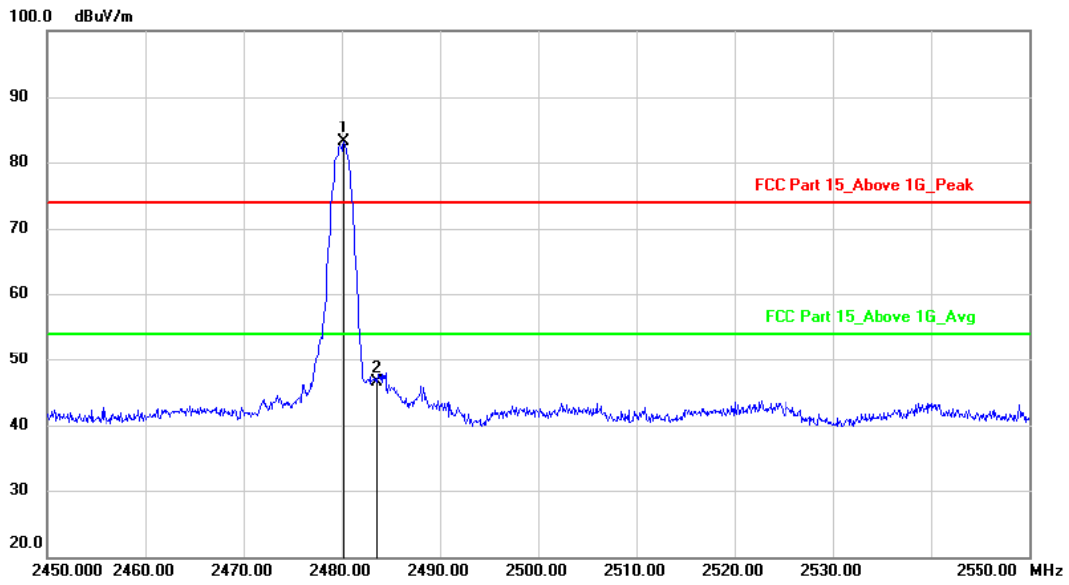

No.	Mk.	Freq.	Reading Level	Correct Factor	Measurement	Limit	Margin	Antenna Height	Table Degree	Comment
		MHz	dBuV	dB	dBuV/m	dBuV/m	dB	cm	degree	
1	*	2480.200	86.40	-3.38	83.02	74.00	9.02			peak
2		2483.500	49.86	-3.38	46.48	74.00	-27.52			peak

hopping-off

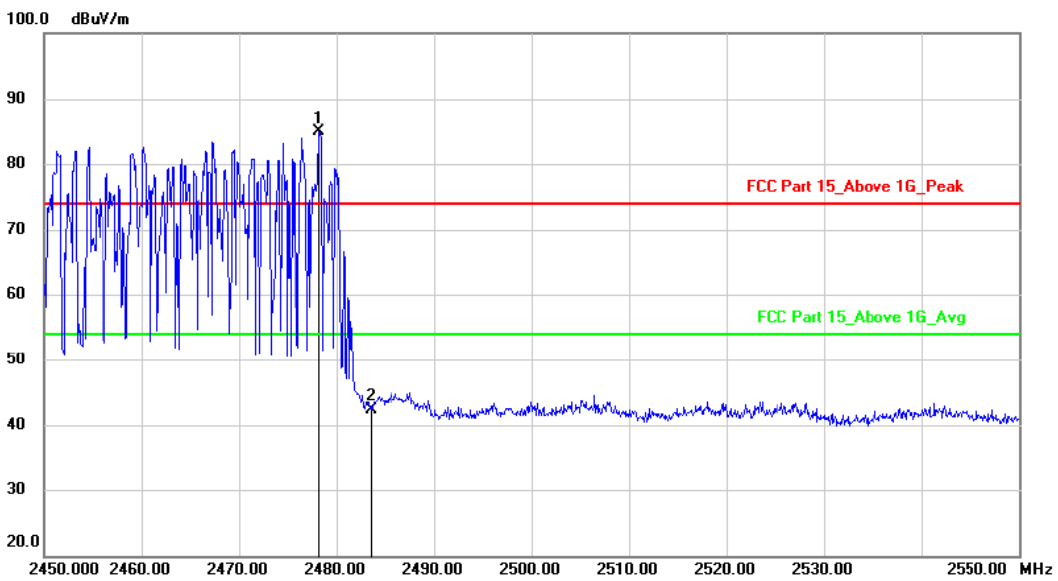

No.	Mk.	Freq.	Reading Level	Correct Factor	Measurement	Limit	Margin	Antenna Height	Table Degree	Comment
		MHz	dBuV	dB	dBuV/m	dBuV/m	dB	cm	degree	
1	*	2478.200	88.22	-3.39	84.83	74.00	10.83			peak
2		2483.500	45.76	-3.38	42.38	74.00	-31.62			peak

hopping-on

Polarization: Horizontal

Test Mode: GFSK-High

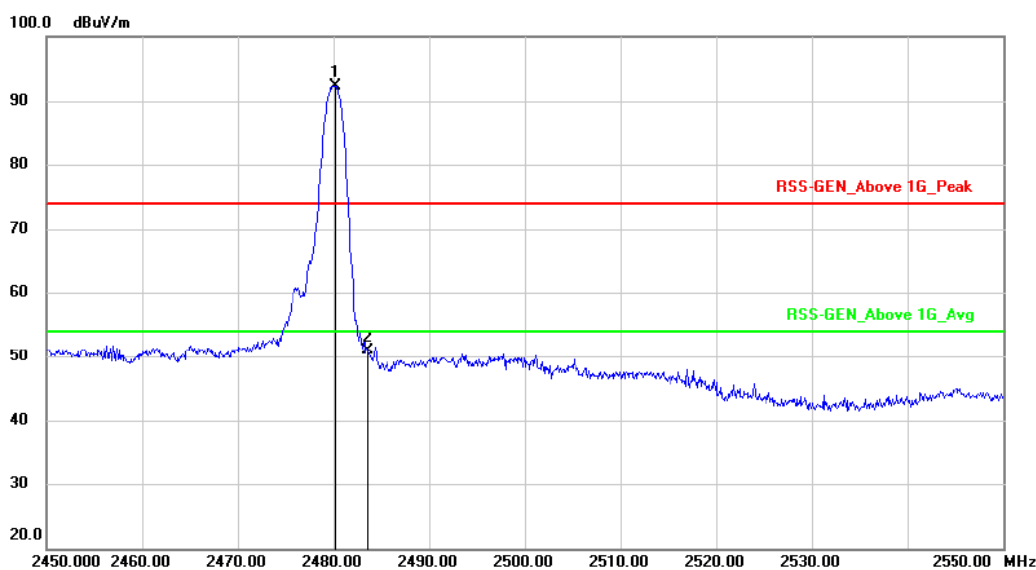

No.	Mk.	Freq.	Reading Level	Correct Factor	Measurement	Limit	Margin	Antenna Height	Table Degree
		MHz	dBuV	dB	dBuV/m	dBuV/m	dB	cm	degree
1	*	2480.200	95.75	-3.38	92.37	74.00	18.37	peak	
2		2483.500	54.32	-3.38	50.94	74.00	-23.06	peak	

hopping-off

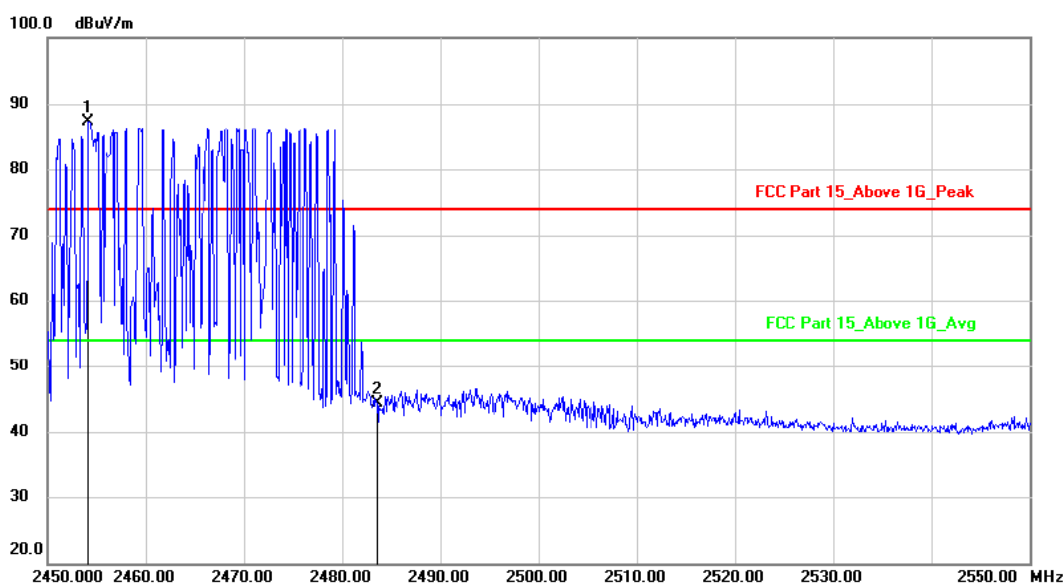

No.	Mk.	Freq.	Reading Level	Correct Factor	Measurement	Limit	Margin	Antenna Height	Table Degree
		MHz	dBuV	dB	dBuV/m	dBuV/m	dB	cm	degree
1	*	2454.100	90.78	-3.39	87.39	74.00	13.39	peak	
2		2483.500	47.67	-3.38	44.29	74.00	-29.71	peak	

hopping-on

Polarization: Vertical

Test Mode: $\pi/4$ DQPSK-Low

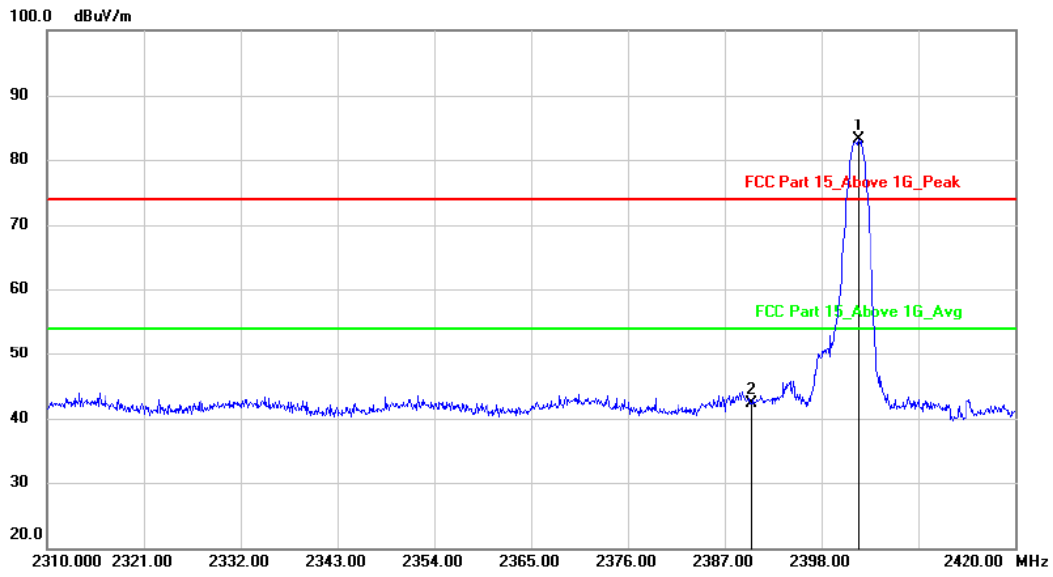

No.	Mk.	Freq.	Reading Level	Correct Factor	Measurement	Limit	Margin	Antenna Height	Table Degree	
		MHz	dBuV	dB	dBuV/m	dBuV/m	dB	cm	degree	Comment
1	*	2402.180	86.50	-3.41	83.09	74.00	9.09			peak
2		2390.000	45.61	-3.40	42.21	74.00	-31.79			peak

hopping-off

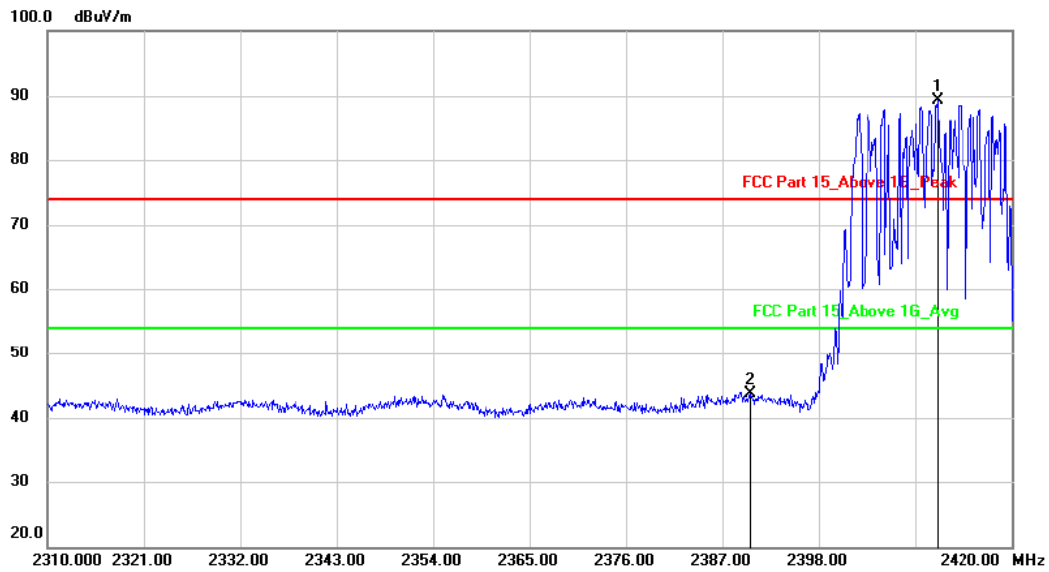

No.	Mk.	Freq.	Reading Level	Correct Factor	Measurement	Limit	Margin	Antenna Height	Table Degree	
		MHz	dBuV	dB	dBuV/m	dBuV/m	dB	cm	degree	Comment
1	*	2411.530	92.79	-3.40	89.39	74.00	15.39			peak
2		2390.000	47.07	-3.40	43.67	74.00	-30.33			peak

hopping-on

Polarization: Horizontal

Test Mode: $\pi/4$ DQPSK-Low

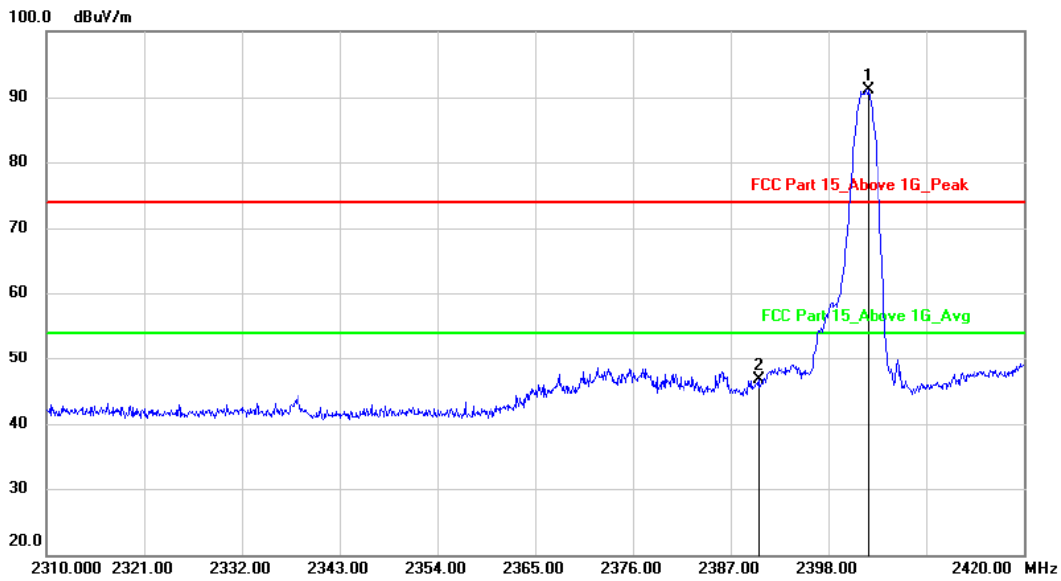

No.	Mk.	Freq.	Reading Level	Correct Factor	Measurement	Limit	Margin	Antenna Height	Table Degree	
		MHz	dBuV	dB	dBuV/m	dBuV/m	dB	cm	degree	Comment
1	*	2402.510	94.48	-3.41	91.07	74.00	17.07			peak
2		2390.000	50.18	-3.40	46.78	74.00	-27.22			peak

hopping-off

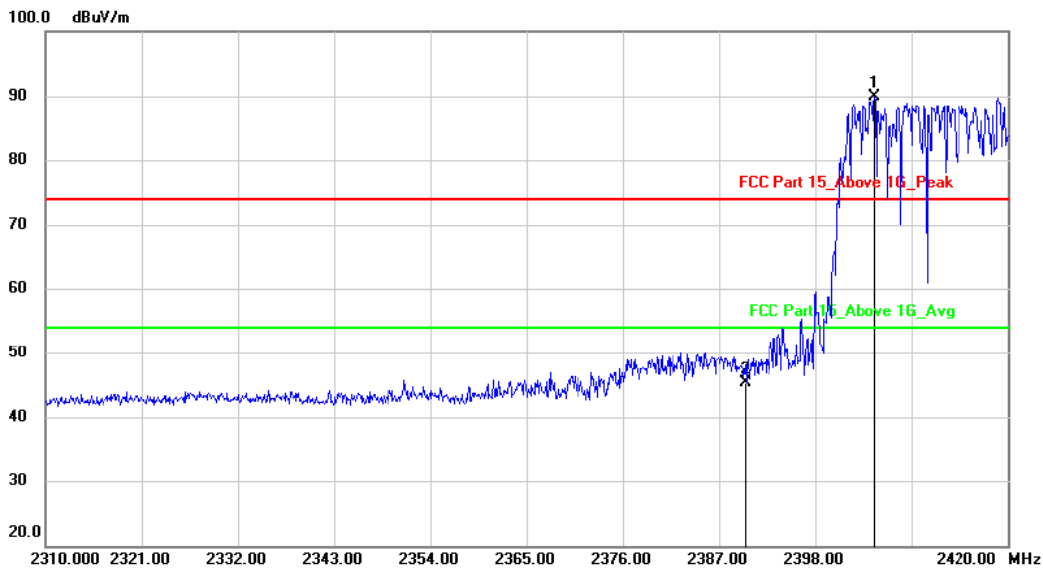

No.	Mk.	Freq.	Reading Level	Correct Factor	Measurement	Limit	Margin	Antenna Height	Table Degree	
		MHz	dBuV	dB	dBuV/m	dBuV/m	dB	cm	degree	Comment
1	*	2404.820	93.24	-3.41	89.83	74.00	15.83			peak
2		2390.000	48.79	-3.40	45.39	74.00	-28.61			peak

hopping-on

Polarization: Vertical

Test Mode: $\pi/4$ DQPSK-High

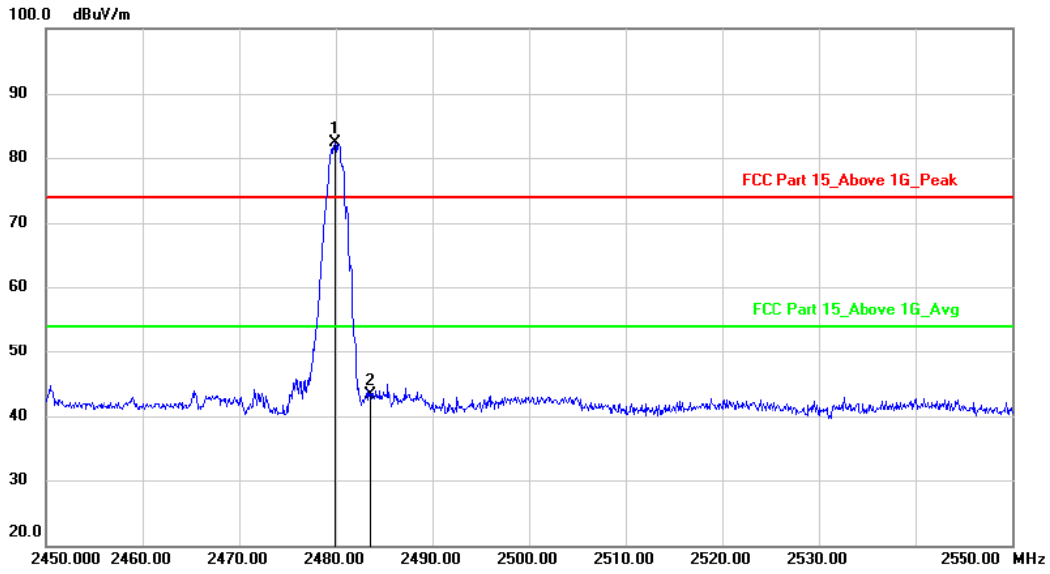

No.	Mk.	Freq.	Reading Level	Correct Factor	Measurement	Limit	Margin	Antenna Height	Table Degree	
		MHz	dBuV	dB	dBuV/m	dBuV/m	dB	cm	degree	Comment
1	*	2479.900	85.69	-3.38	82.31	74.00	8.31			peak
2		2483.500	46.71	-3.38	43.33	74.00	-30.67			peak

hopping-off

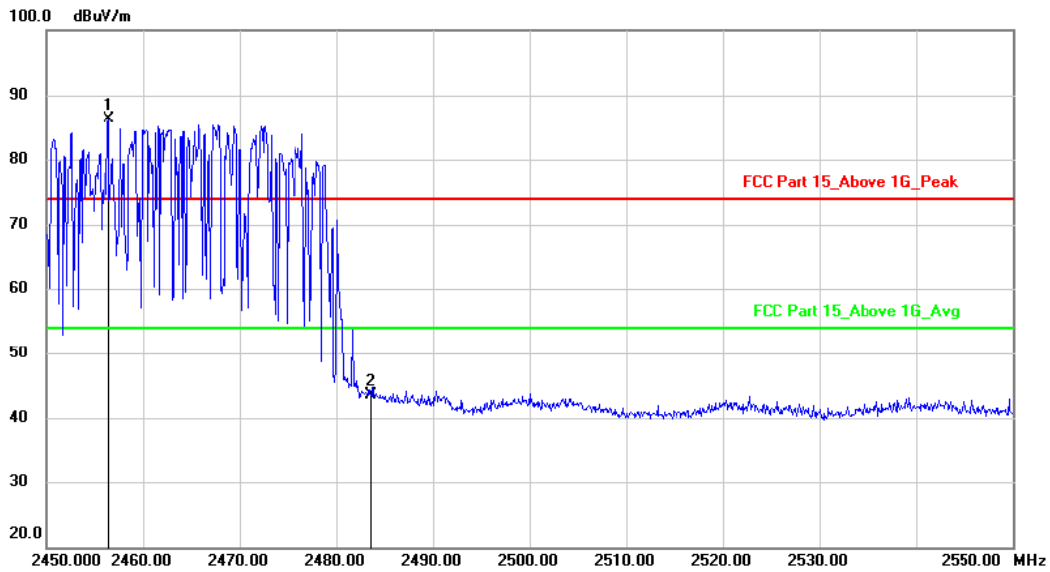

No.	Mk.	Freq.	Reading Level	Correct Factor	Measurement	Limit	Margin	Antenna Height	Table Degree	
		MHz	dBuV	dB	dBuV/m	dBuV/m	dB	cm	degree	Comment
1	*	2456.400	89.72	-3.39	86.33	74.00	12.33			peak
2		2483.500	46.92	-3.38	43.54	74.00	-30.46			peak

hopping-on

Polarization: Horizontal

Test Mode: $\pi/4$ DQPSK-High

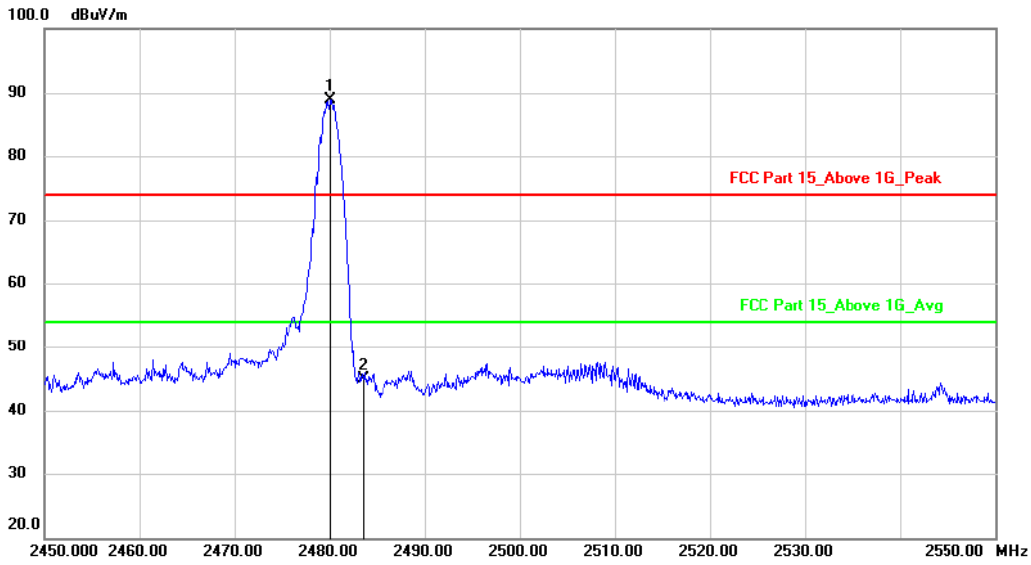

No.	Mk.	Freq.	Reading Level	Correct Factor	Measurement	Limit	Margin	Antenna Height	Table Degree	
		MHz	dBuV	dB	dBuV/m	dBuV/m	dB	cm	degree	Comment
1	*	2480.000	92.32	-3.38	88.94	74.00	14.94			peak
2		2483.500	48.36	-3.38	44.98	74.00	-29.02			peak

hopping-off

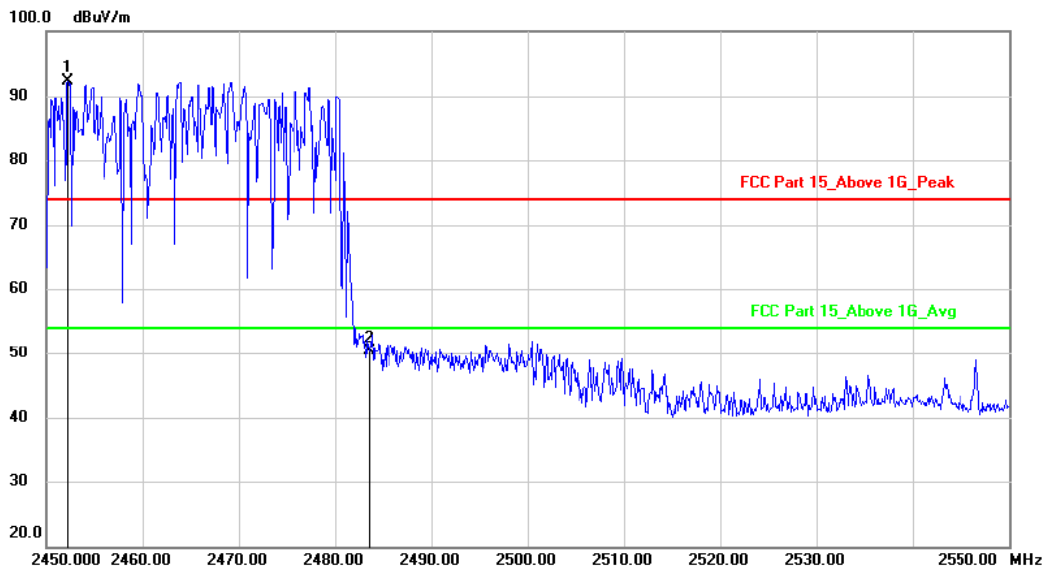

No.	Mk.	Freq.	Reading Level	Correct Factor	Measurement	Limit	Margin	Antenna Height	Table Degree	
		MHz	dBuV	dB	dBuV/m	dBuV/m	dB	cm	degree	Comment
1	*	2452.200	95.75	-3.39	92.36	74.00	18.36			peak
2		2483.500	53.74	-3.38	50.36	74.00	-23.64			peak

hopping-on

Polarization: Vertical

Test Mode: 8DPSK-Low

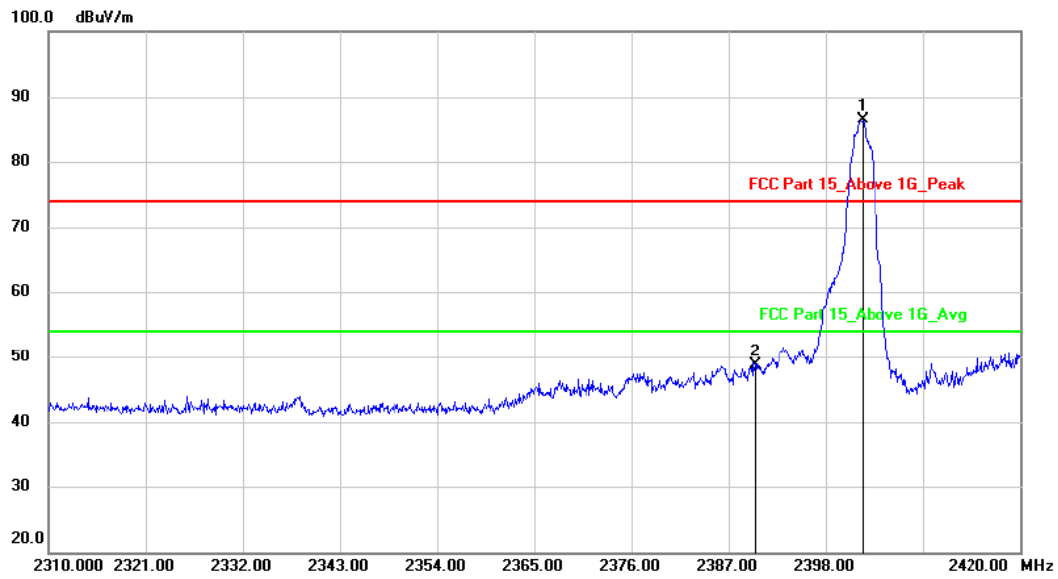

No.	Mk.	Freq. MHz	Reading Level dBuV	Correct Factor dB	Measure- ment dBuV/m	Limit dBuV/m	Margin dB	Detector	Antenna Height cm	Table Degree degree	Comment
1	*	2402.180	90.01	-3.41	86.60	74.00	12.60	peak			
2		2390.000	52.01	-3.40	48.61	74.00	-25.39	peak			

hopping-off

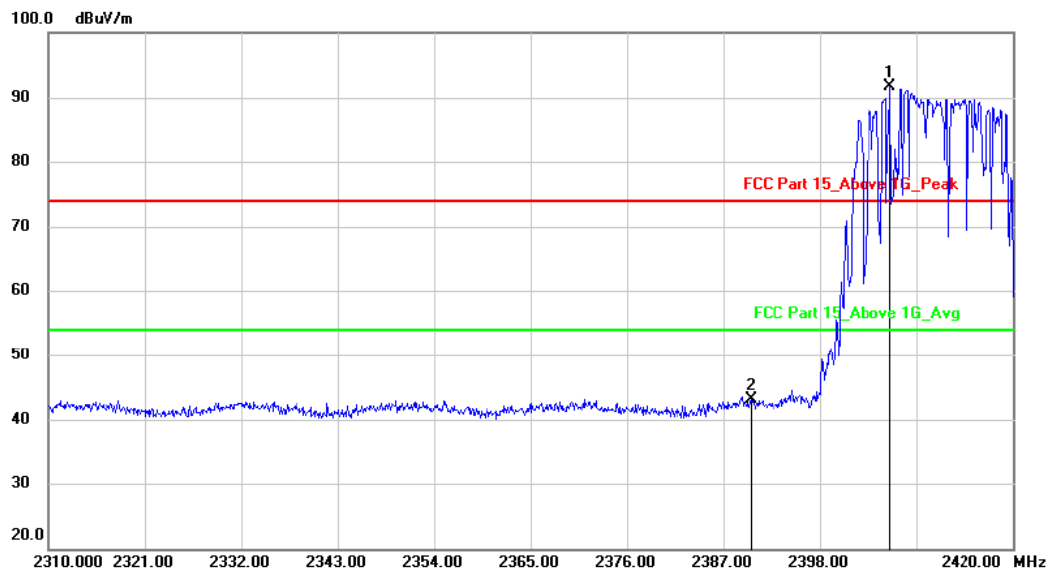

No.	Mk.	Freq. MHz	Reading Level dBuV	Correct Factor dB	Measure- ment dBuV/m	Limit dBuV/m	Margin dB	Detector	Antenna Height cm	Table Degree degree	Comment
1	*	2406.030	95.16	-3.41	91.75	74.00	17.75	peak			
2		2390.000	46.57	-3.40	43.17	74.00	-30.83	peak			

hopping-on

Polarization: Horizontal

Test Mode: 8DPSK-Low

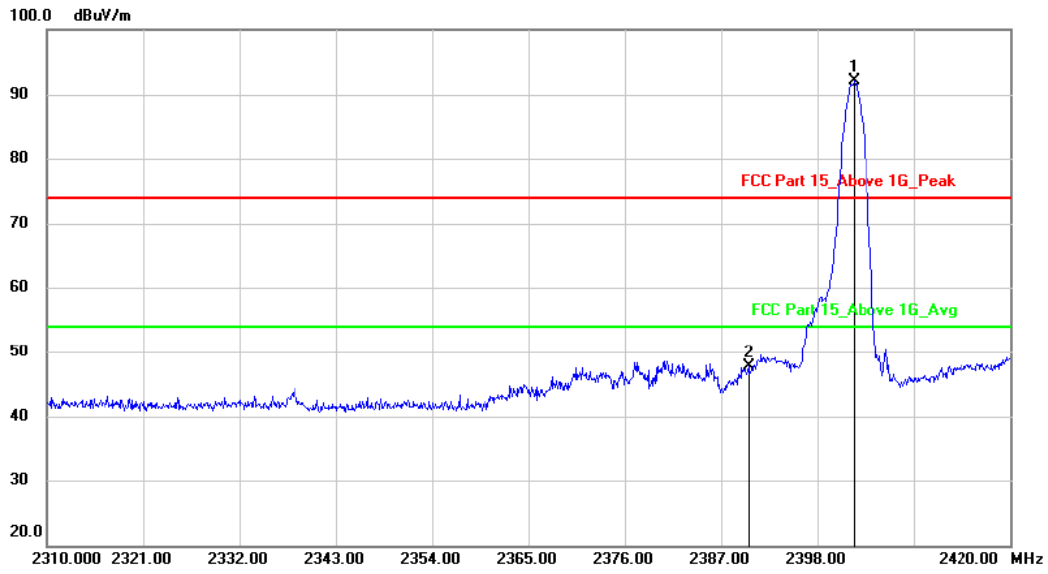

No.	Mk.	Freq.	Reading Level	Correct Factor	Measurement	Limit	Margin	Antenna Height	Table Degree	
		MHz	dBuV	dB	dBuV/m	dBuV/m	dB	cm	degree	Comment
1	*	2402.180	95.42	-3.41	92.01	74.00	18.01	peak		
2		2390.000	51.18	-3.40	47.78	74.00	-26.22	peak		

hopping-off

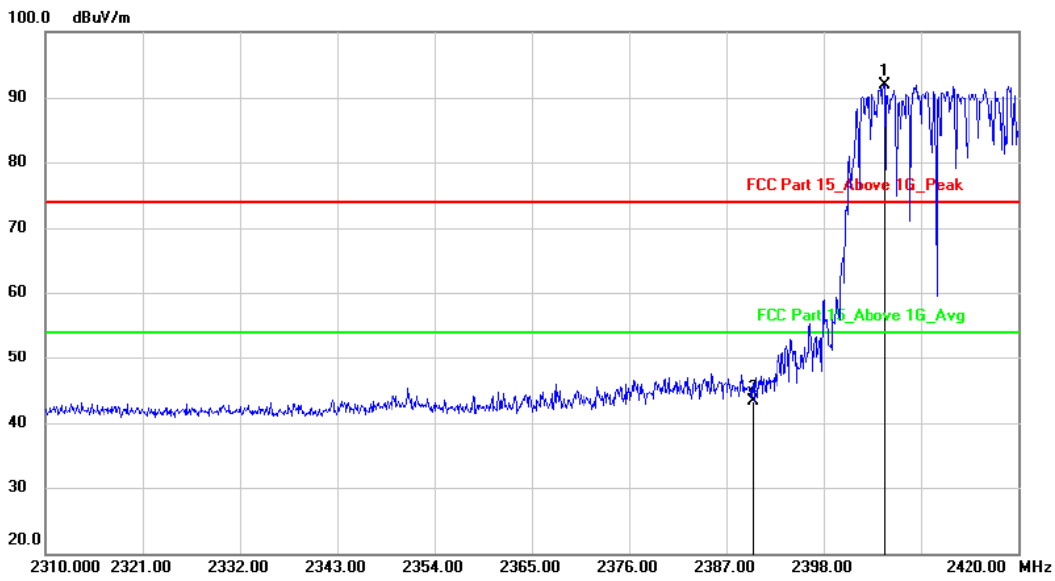

No.	Mk.	Freq.	Reading Level	Correct Factor	Measurement	Limit	Margin	Antenna Height	Table Degree	
		MHz	dBuV	dB	dBuV/m	dBuV/m	dB	cm	degree	Comment
1	*	2404.930	95.26	-3.41	91.85	74.00	17.85	peak		
2		2390.000	46.79	-3.40	43.39	74.00	-30.61	peak		

hopping-on

Polarization: Vertical

Test Mode: 8DPSK-High

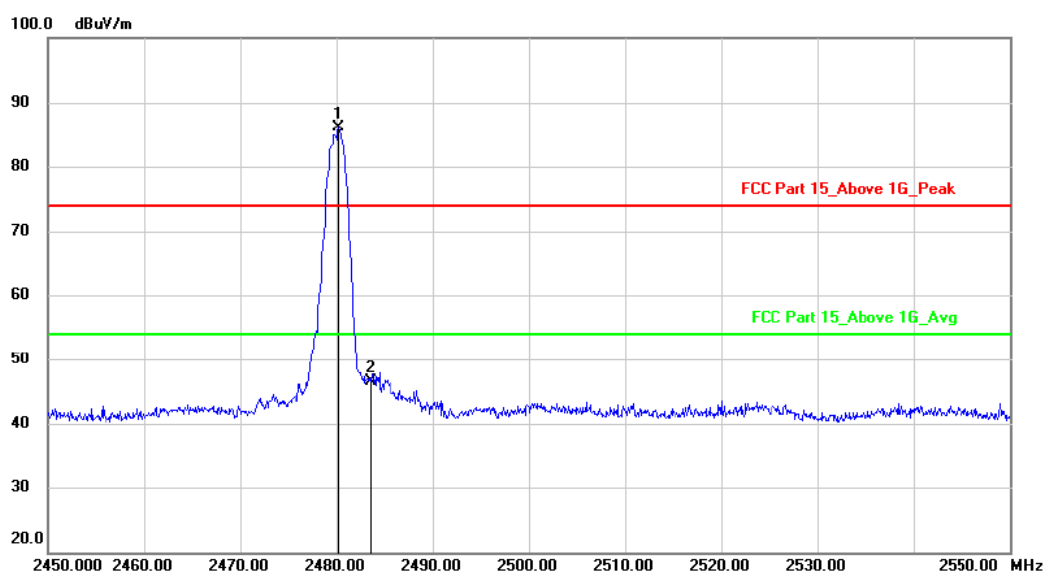

No.	Mk.	Freq.	Reading Level	Correct Factor	Measurement	Limit	Margin	Antenna Height	Table Degree	
		MHz	dBuV	dB	dBuV/m	dBuV/m	dB	cm	degree	Comment
1	*	2480.200	89.40	-3.38	86.02	74.00	12.02			peak
2		2483.500	49.86	-3.38	46.48	74.00	-27.52			peak

hopping-off

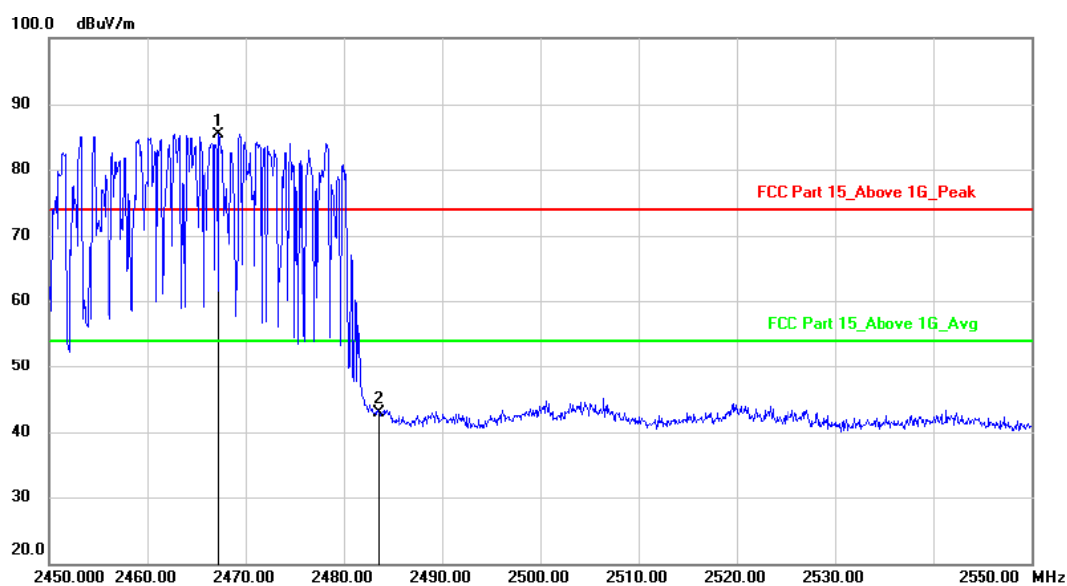

No.	Mk.	Freq.	Reading Level	Correct Factor	Measurement	Limit	Margin	Antenna Height	Table Degree	
		MHz	dBuV	dB	dBuV/m	dBuV/m	dB	cm	degree	Comment
1	*	2467.300	88.75	-3.39	85.36	74.00	11.36			peak
2		2483.500	46.26	-3.38	42.88	74.00	-31.12			peak

hopping-on

Polarization: Horizontal

Test Mode: 8DPSK-High

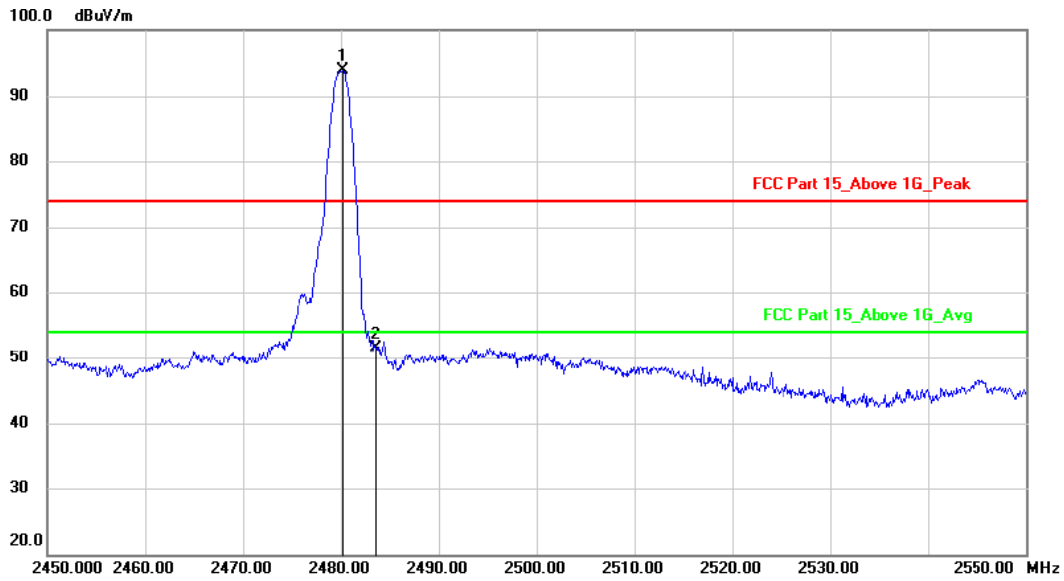

No.	Mk.	Freq. MHz	Reading Level dBuV	Correct Factor dB	Measure- ment dBuV/m	Limit dBuV/m	Margin dB	Detector	Antenna Height cm	Table Degree degree	Comment
1	*	2480.200	97.25	-3.38	93.87	74.00	19.87	peak			
2		2483.500	54.82	-3.38	51.44	74.00	-22.56	peak			

hopping-off

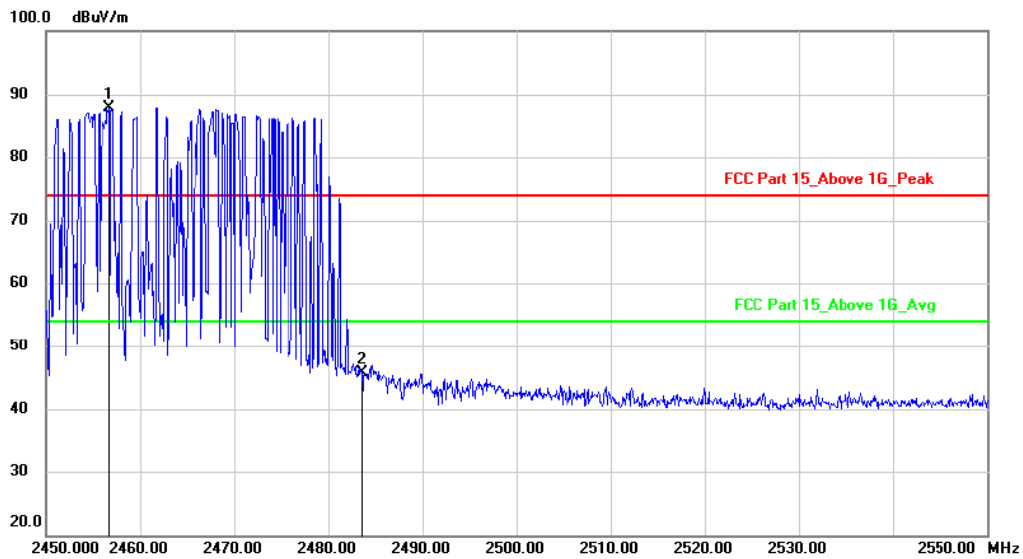

No.	Mk.	Freq. MHz	Reading Level dBuV	Correct Factor dB	Measure- ment dBuV/m	Limit dBuV/m	Margin dB	Detector	Antenna Height cm	Table Degree degree	Comment
1	*	2456.700	91.33	-3.39	87.94	74.00	13.94	peak			
2		2483.500	49.17	-3.38	45.79	74.00	-28.21	peak			

hopping-on

Note: 1. *:Maximum data; x:Over limit; !:over margin.

2.Measurement=Reading Level+Correct Factor; Correct Factor=Antenna Factor+Cable Loss.

Conducted Method

GFSK Mode:

Test channel:

Lowest channel

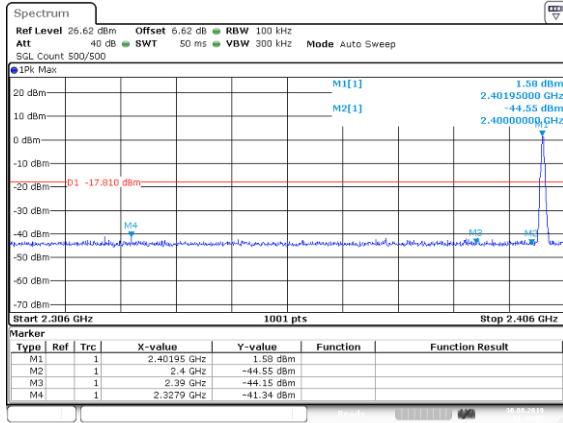

Date: 30.AUG.2019 11:44:03

No-hopping mode

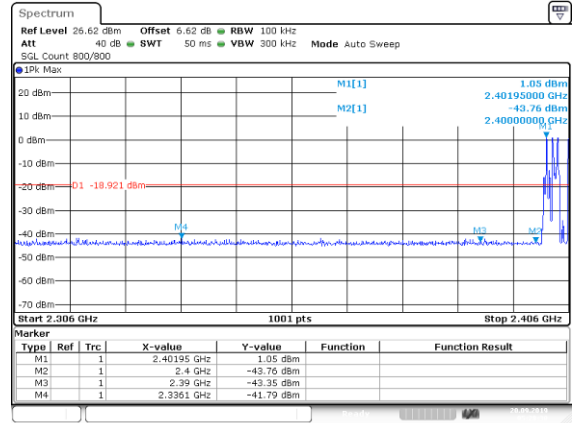

Date: 20.SEP.2019 05:28:30

Hopping mode

Test channel:

Highest channel

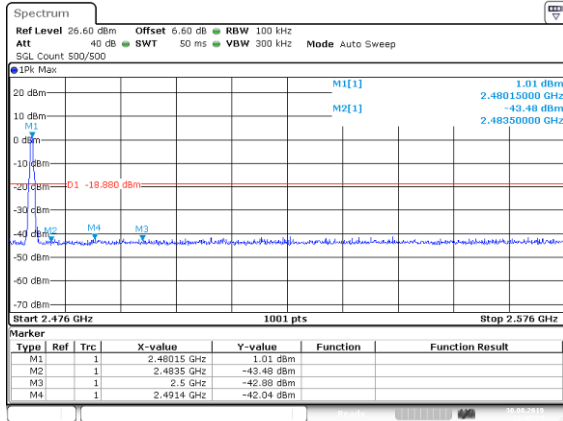

Date: 30.AUG.2019 11:42:24

No-hopping mode

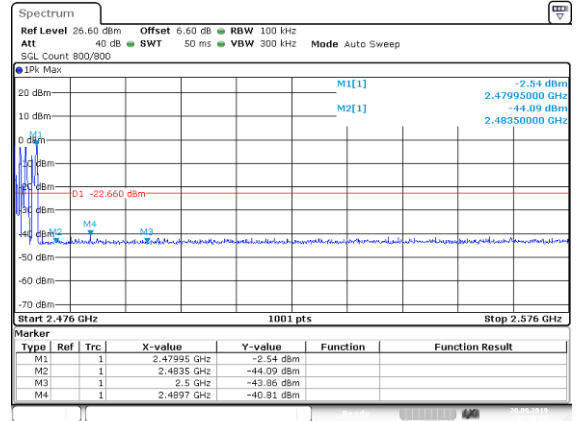

Date: 20.SEP.2019 05:30:07

Hopping mode

Pi/4QPSK Mode:

Test channel:

Lowest channel

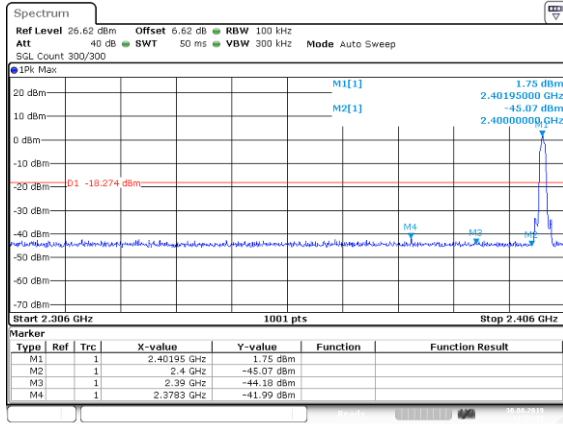

Date: 30.AUG.2019 11:51:13

No-hopping mode

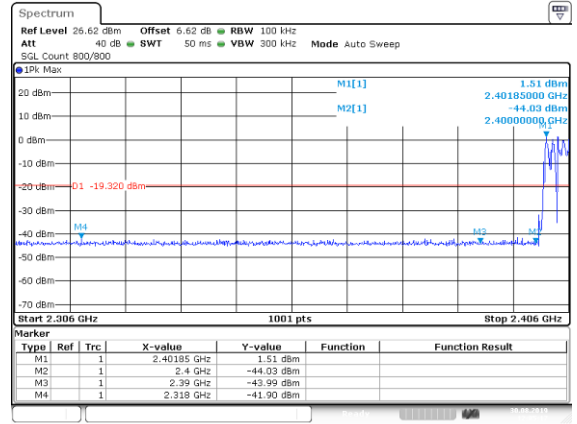

Date: 30.AUG.2019 12:05:17

Hopping mode

Test channel:

Highest channel

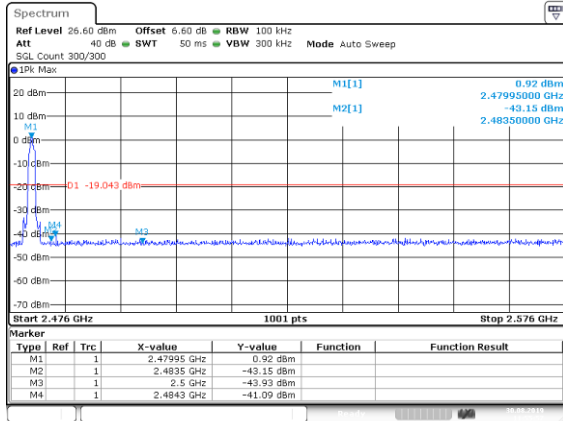

Date: 30.AUG.2019 11:55:57

No-hopping mode

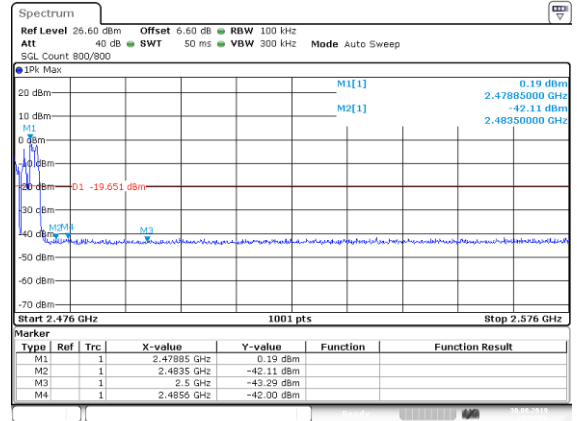

Date: 30.AUG.2019 12:03:55

Hopping mode

8DPSK Mode:

Test channel: Lowest channel

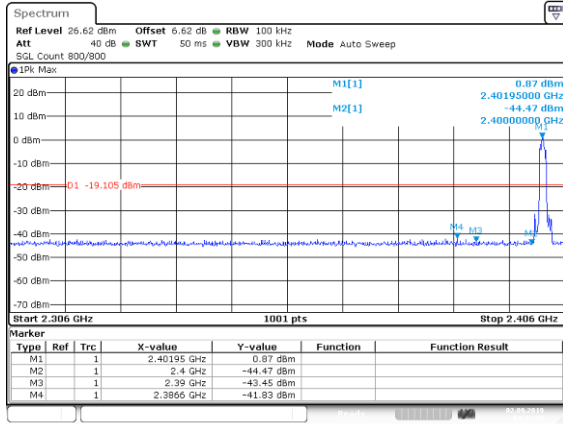

No-hopping mode

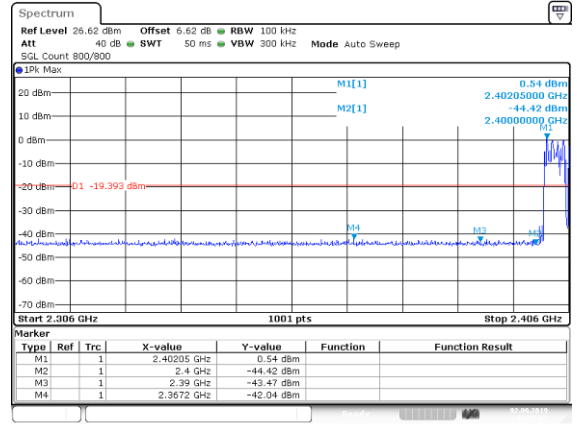

Hopping mode

Test channel: Highest channel

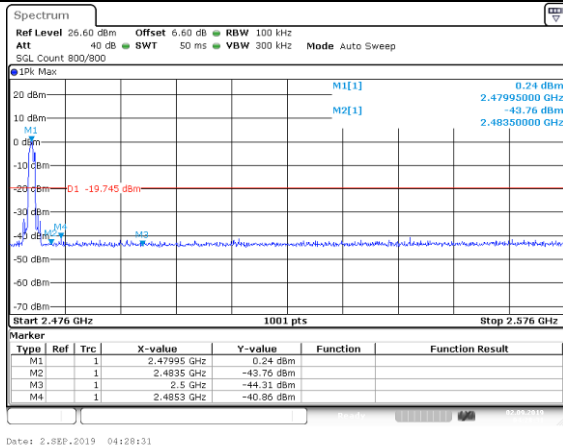

No-hopping mode

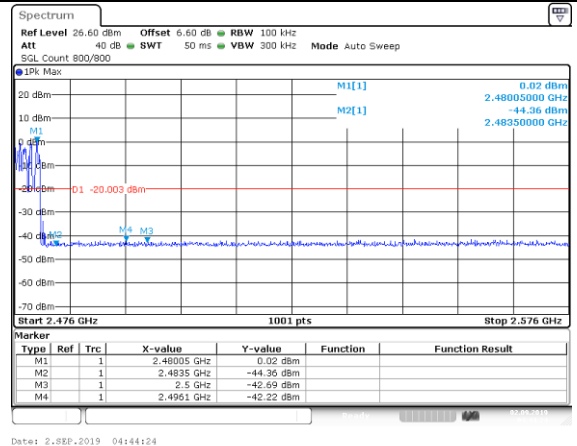

Hopping mode

10. POWER LINE CONDUCTED EMISSIONS

10.1. Block Diagram of Test Setup

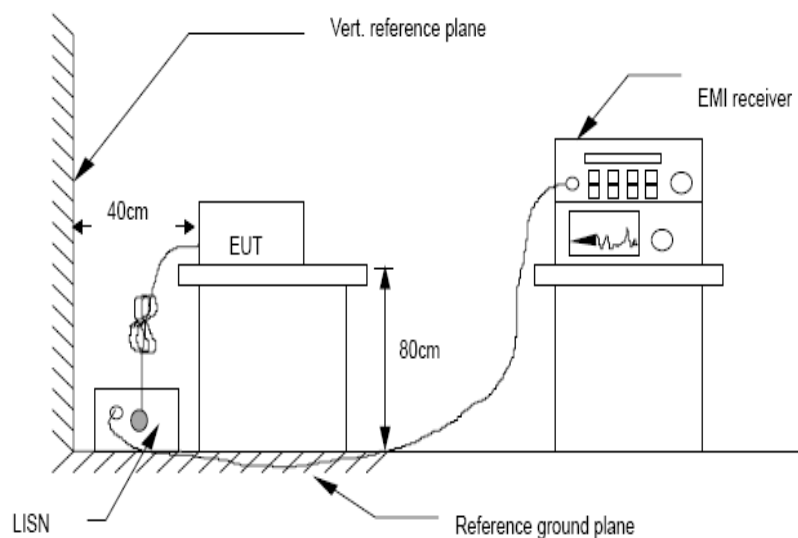

10.2. Limit

Frequency	Maximum RF Line Voltage	
	Quasi-Peak Level dB(μ V)	Average Level dB(μ V)
150kHz ~ 500kHz	66 ~ 56*	56 ~ 46*
500kHz ~ 5MHz	56	46
5MHz ~ 30MHz	60	50

Notes: 1. * Decreasing linearly with logarithm of frequency.

2. The lower limit shall apply at the transition frequencies.

10.3. Test Procedure

- (1) The EUT was placed on a non-metallic table, 80cm above the ground plane.
- (2) Setup the EUT and simulator as shown in 10.1
- (3) The EUT Power connected to the power mains through a power adapter and a line impedance stabilization network (L.I.S.N1). The other peripheral devices power cord connected to the power mains through a line impedance stabilization network (L.I.S.N2), this provided a 50-ohm coupling impedance for the EUT (Please refer to the block diagram of the test setup and photographs). Both sides of power line were checked for maximum conducted interference. In order to find the maximum emission, the relative positions of equipments and all of the interface cables were changed according to ANSI C63.10:2013on conducted Emission test.
- (4) The bandwidth of test receiver is set at 10KHz.

(5) The frequency range from 150 KHz to 30MHz is checked.

10.4. Test Result

PASS. (See below detailed test data)

Note: If peak Result comply with AV limit, QP and AV Result is deemed to comply with AV limit

Line:

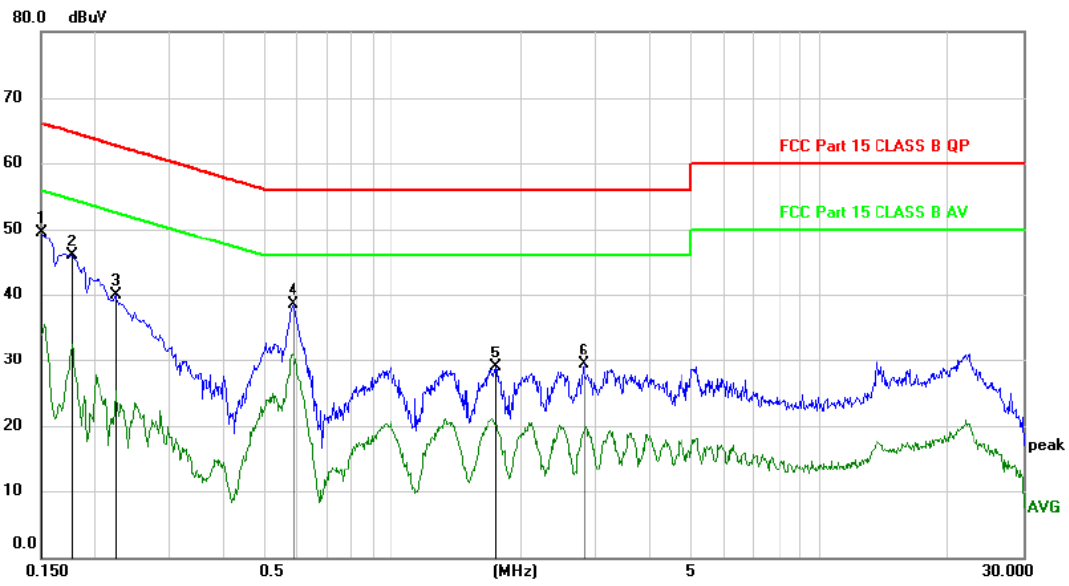

No. Mk.	Freq. MHz	Reading Level dBuV	Correct Factor dB	Measurement dBuV	Limit dBuV	Margin dB	Detector	Comment
1 *	0.1500	39.94	9.66	49.60	66.00	-16.40	peak	
2	0.1770	36.33	9.67	46.00	64.63	-18.63	peak	
3	0.2250	30.30	9.68	39.98	62.63	-22.65	peak	
4	0.5850	28.84	9.72	38.56	56.00	-17.44	peak	
5	1.7490	19.08	9.85	28.93	56.00	-27.07	peak	
6	2.8020	19.32	9.97	29.29	56.00	-26.71	peak	

*:Maximum data x:Over limit !:over margin

(Reference Only)

Note: Measurement=Reading Level+Correc Factor. Factor=(LISN or ISN or PLC or Current Probe)Factor+Cable

Neutral:

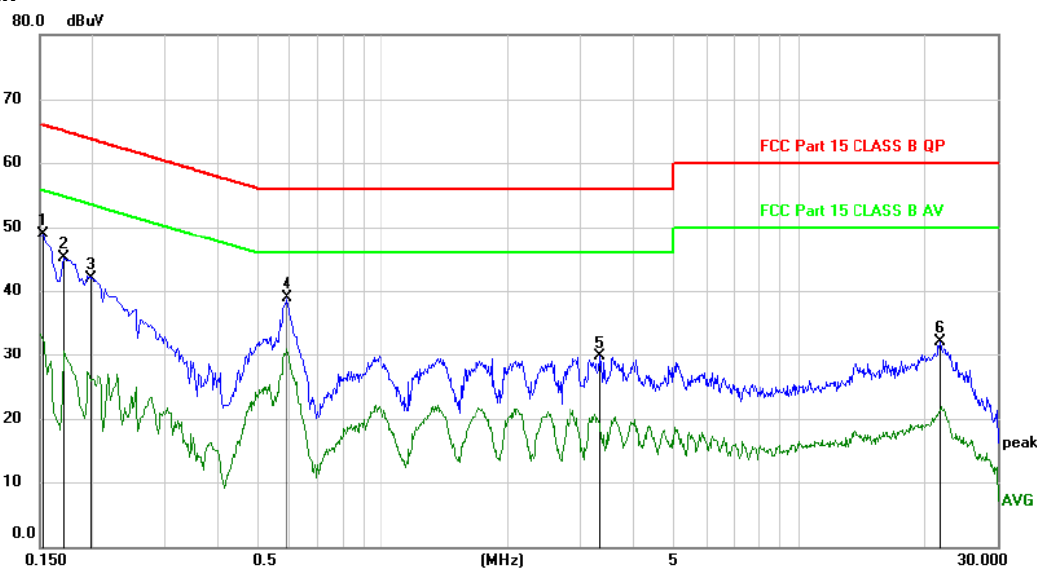

No.	Mk.	Freq. MHz	Reading Level dBuV	Correct Factor dB	Measure- ment dBuV	Limit dBuV	Margin dB	Detector	Comment
1	*	0.1530	39.22	9.66	48.88	65.84	-16.96	peak	
2		0.1710	35.44	9.66	45.10	64.91	-19.81	peak	
3		0.1986	32.29	9.67	41.96	63.67	-21.71	peak	
4		0.5910	29.12	9.72	38.84	56.00	-17.16	peak	
5		3.3210	19.74	10.02	29.76	56.00	-26.24	peak	
6		21.8070	21.50	10.58	32.08	60.00	-27.92	peak	

*:Maximum data x:Over limit !:over margin (Reference Only)
 Note: Measurement=Reading Level+Correc Factor. Factor=(LISN or ISN or PLC or Current Probe)Factor+Cable

Remark: All modes have been tested, and only worst data of GFSK mode, Channel 2441MHz (AC 120V/60Hz) was listed in this report.

11.FREQUENCY STABILITY

11.1.Test limit

Please refer section RSS-Gen.

Regulation RSS-Gen If the frequency stability of the licence-exempt radio apparatus is not specified in the applicable RSS, the fundamental emissions of the radio apparatus should be kept within at least the central 80% of its permitted operating frequency band in order to minimize the possibility of out-of-band operation. In addition, its occupied bandwidth shall be entirely outside the restricted bands and the prohibited TV bands of 54-72 MHz, 76-88 MHz, 174-216 MHz, and 470-602 MHz, unless otherwise indicated.

11.2.Test Procedure

The following equipment are installed on the emission measurement to meet the commission requirements and operating regulations in a manner which tends to maximize its emission characteristics in normal application.

11.3.Test Setup

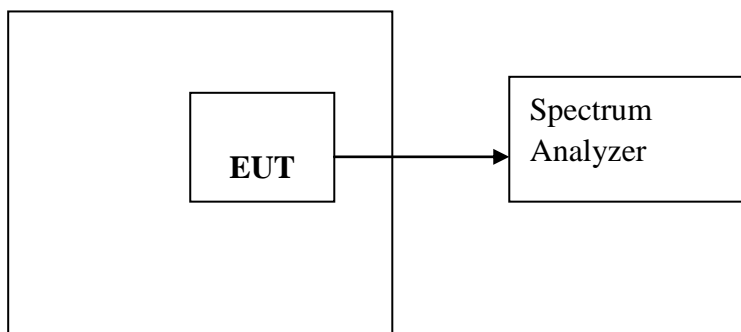

Temperature controller

11.4.Test Results

PASS.

Detailed information please see the following page.

Assigned Frequency(MHz): 2402MHz(GFSK)				
Voltage	Temperature	Measured Frequency (MHz)	Frequency stability(MHz)	Limit(MHz)
Low DC 6.1V	+20°C	2402.008	0.008	±0.020
Normal DC 7.2V	-20°C	2401.990	-0.010	±0.020
	-10°C	2401.993	-0.007	±0.020
	0°C	2401.992	-0.008	±0.020
	+10°C	2402.008	0.008	±0.020
	+20°C	2402.004	0.004	±0.020
	+30°C	2402.006	0.006	±0.020
	+40°C	2401.992	-0.008	±0.020
	+50°C	2401.989	-0.011	±0.020
High DC 8.3V	+20°C	2401.992	-0.008	±0.020

12.ANTENNA REQUIREMENTS

12.1.Limit

For intentional device, according to FCC 47 CFR Section 15.203 and RSS-GEN, an intentional radiator shall be designed to ensure that no antenna other than that furnished by the responsible party shall be used with the device. And according to FCC 47 CFR Section 15.247 (b), if transmitting antennas of directional gain greater than 6dBi are used, the power shall be reduced by the amount in dB that the directional gain of the antenna exceeds 6dBi.

12.2.Result

The EUT antenna is internal antenna. It complies with the standard requirement.

-----THE END OF REPORT-----