



# TEST REPORT

**FCC ID: SY4-A01010**

For

Shanghai Huace Navigation Technology LTD.

GNSS Receiver

Model No. : i70, iG8

Trade name : The logo for CHC, consisting of a stylized globe icon in blue and yellow, followed by the letters 'CHC' in a bold, blue, sans-serif font.

Prepared for : Shanghai Huace Navigation Technology LTD.

Address : Building C,599 Gaojing Road,Qingpu District,Shanghai,China

Prepared by : Shenzhen Alpha Product Testing Co., Ltd.

Address : Building B, East Area of Nanchang Second, Industrial Zone,  
Gushu 2nd Road, Bao'an, Shenzhen, China

Report No. : T1871060 01

Date of Receipt : June 22, 2017

Date of Test : June 22, 2017- July 11, 2017

Date of Report : July 11, 2017

## TABLE OF CONTENT

Description	Page
<b>1. Summary of Standards and Results -----</b>	<b>5</b>
1.1. Description of Standards and Results -----	5
<b>2. General Information-----</b>	<b>6</b>
2.1. Description of Device (EUT)-----	6
2.2. Accessories of Device (EUT)-----	7
2.3. Tested Supporting System Details -----	7
2.4. Test Mode Description-----	7
2.5. Test Conditions -----	8
2.6. Block Diagram of connection between EUT and simulators -----	8
2.7. Test Facility -----	8
2.8. Measurement Uncertainty-----	8
2.9. Test Equipment List-----	9
<b>3. Spurious Emission-----</b>	<b>10</b>
3.1. Test Limits-----	10
3.2. Test Procedure -----	10
3.3. Test Setup-----	11
3.4. Test Results-----	12
<b>4. Power line Conducted Emission -----</b>	<b>18</b>
4.1. Test Limits-----	18
4.2. Test Procedure -----	18
4.3. Test Setup-----	18
4.4. Test Results-----	19
<b>5 Conducted Maximum Output Power -----</b>	<b>21</b>
5.1 Test limits -----	21
5.2 Test Procedure -----	21
5.3 Test Setup -----	21
5.4 Test Results -----	21
<b>6 Peak Power Spectral Density-----</b>	<b>23</b>
6.1 Test limits -----	23
6.2 Test Procedure -----	23
6.3 Test Setup -----	23
6.4 Test Results -----	24
<b>7 Bandwidth-----</b>	<b>30</b>
7.1 Test limits -----	30
7.2 Test Procedure -----	30
7.3 Test Setup -----	30
7.4 Test Results -----	30
<b>8 Band Edge Check-----</b>	<b>36</b>
8.1 Test limits -----	36
8.2 Test Procedure -----	36
8.3 Test Setup -----	36
8.4 Test Results -----	36
<b>9 Antenna Requirement-----</b>	<b>41</b>

9.1 Standard Requirement -----41  
9.2 Antenna Connected Construction -----41  
9.3 Results -----41

# DECLARATION

Applicant : Shanghai Huace Navigation Technology LTD.  
 Manufacturer : Shanghai Huace Navigation Technology LTD.  
 EUT Description : GNSS Receiver  
 (A) Model No. : i70, iG8  
 (B) Trademark :   
 (C) Ratings Supply : DC 15V from adapter input 120V/60Hz

Measurement Standard Used:

**FCC Rules and Regulations Part 15 Subpart C Section 15.247: 2016,**  
**ANSI C 63.4-2014, ANSI C63.10-2013**

The device described above is tested by Shenzhen Alpha Product Testing Co., Ltd. to determine the maximum emission levels emanating from the device. The maximum emission levels are compared to the FCC Part 15 Subpart C limits both conducted and radiated emissions. The test results are contained in this test report and Shenzhen Alpha Product Testing Co., Ltd. is assumed of full responsibility for the accuracy and completeness of these tests.

After the test, our opinion is that EUT compliance with the requirement of the above standards.

This report applies to above tested sample only. This report shall not be reproduced in parts without written approval of Shenzhen Alpha Product Testing Co., Ltd.

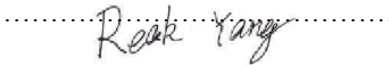
Tested by (name + signature).....: Reak Yang  
 Project Engineer 

Approved by (name + signature).....: Simple Guan  
 Project Manager 

Date of issue.....: July 11, 2017

## 1. Summary of Standards and Results

### 1.1. Description of Standards and Results

Note: The EUT has been tested as an independent unit. And Continual Transmitting in maximum power (The adapter be used during Test)

Test Item	Test Requirement	Standards Paragraph	Result
Conducted Emission	FCC PART 15:2016	15.207	P
6dB Bandwidth	FCC PART 15:2016	15.247 (a)(2)	P
Output Power	FCC PART 15:2016	15.247 (b)(3)	P
Radiated Spurious Emission	FCC PART 15:2016	15.247 (c)	P
Conducted Spurious & Band Edge Emission	FCC PART 15:2016	15.247 (d)	P
Power Spectral Density	FCC PART 15:2016	15.247 (e)	P
Radiated Band Edge Emission	FCC PART 15:2016	15.205	P
Antenna Requirement	FCC PART 15:2016	15.203	P
Note:	1. P is an abbreviation for Pass. 2. F is an abbreviation for Fail. 3. N/A is an abbreviation for Not Applicable.		

## 2. General Information

### 2.1. Description of Device (EUT)

Trade Name : 

EUT : GNSS Receiver

Model No. : i70, iG8

DIFF. : All the models are the same, except the model name, this report performs the model i70.

Antenna Type : PCB Antenna, Maximum Gain is 1.0dBi

Operation Frequency : IEEE 802.11b/g: 2412MHz-2462MHz  
IEEE 802.11n HT20: 2412MHz-2462MHz

Channel number : IEEE 802.11b/g: 11 Channels  
IEEE 802.11n HT20: 11 Channels  
IEEE 802.11b: DSSS(CCK,DQPSK,DBPSK)

Modulation type : IEEE 802.11g: OFDM(64QAM, 16QAM, QPSK, BPSK)  
IEEE 802.11n :OFDM(64QAM, 16QAM, QPSK, BPSK)

Power Supply : DC 15V from adapter input 120V/60Hz

Applicant : Shanghai Huace Navigation Technology LTD.

Address : Building C,599 Gaojing Road,Qingpu District,Shanghai,China

Manufacturer : Shanghai Huace Navigation Technology LTD.

Address : Building C,599 Gaojing Road,Qingpu District,Shanghai,China

## 2.2. Accessories of Device (EUT)

Power Source	:	Input: AC 100-240V Output: DC 12-36V/2A LI-ION battery: 3400mAh/7.4V*2
USB Cable	:	USB port to PC 1.5m
Data Cable	:	IO port to PC with RS-232/external power 1.8m

## 2.3. Tested Supporting System Details

No.	Description	Manufacturer	Model	Serial Number	Certification or DOC
1	Notebook	ACER	ZQT	N/A	DOC

## 2.4. Test Mode Description

Duty cycle :100% Keeping TX			
Mode	data rate (Mbps)(see Note)	Channel	Frequency (MHz)
IEEE 802.11b	1	Low :CH1	2412
	1	Middle: CH6	2437
	1	High: CH11	2462
IEEE 802.11g	6	Low :CH1	2412
	6	Middle: CH6	2437
	6	High: CH11	2462
IEEE 802.11 n/HT20 with 2.4G	6.5	Low :CH1	2412
	6.5	Middle: CH6	2437
	6.5	High: CH11	2462

Note: According exploratory test, EUT will have maximum output power in those data rate. so those data rate were used for all test.

### Channel list:

For IEEE 802.11b/g and IEEE 802.11n/HT20 with 2.4G					
Channel	Frequency (MHz)	Channel	Frequency (MHz)	Channel	Frequency (MHz)
CH1	2412	CH5	2432	CH9	2452
CH2	2417	CH6	2437	CH10	2457
CH3	2422	CH7	2442	CH11	2462
CH4	2427	CH8	2447		

## 2.5. Test Conditions

Items	Required	Actual
Temperature range:	15-35°C	27°C
Humidity range:	25-75%	56%
Pressure range:	86-106kPa	980kPa

## 2.6. Block Diagram of connection between EUT and simulators



## 2.7. Test Facility

Shenzhen Alpha Product Testing Co., Ltd  
 Building B, East Area of Nanchang Second, Industrial Zone, Gushu 2nd Road,  
 Bao'an, Shenzhen, China

August 11, 2014 File on Federal Communication Commission  
 Registration Number: 203110

July 18, 2014 Certificated by IC  
 Registration Number: 12135A

## 2.8. Measurement Uncertainty

(95% confidence levels, k=2)

Item	Uncertainty
Uncertainty for Power point Conducted Emissions Test	2.42dB
Uncertainty for Radiation Emission test in 3m chamber (below 30MHz)	2.13 dB(Polarize: V)
	2.57dB(Polarize: H)
Uncertainty for Radiation Emission test in 3m chamber (30MHz to 1GHz)	3.54dB(Polarize: V)
	4.1dB(Polarize: H)
Uncertainty for Radiation Emission test in 3m chamber (1GHz to 25GHz)	2.08dB(Polarize: H)
	2.56dB(Polarize: V)
Uncertainty for radio frequency	$1 \times 10^{-9}$
Uncertainty for conducted RF Power	0.65dB
Uncertainty for temperature	0.2°C
Uncertainty for humidity	1%
Uncertainty for DC and low frequency voltages	0.06%



## 2.9. Test Equipment List

Equipment	Manufacture	Model No.	Serial No.	Cal. Date	Cal Interval
3m Semi-Anechoic	CHENYU	N/A	N/A	2017.01.18	1Year
Spectrum analyzer	Agilent	E4407B	MY46185649	2017.01.16	1Year
Receiver	R&S	ESPI	101873	2017.01.16	1Year
Receiver	R&S	ESCI	101165	2017.01.16	1Year
Bilog Antenna	SCHWARZBECK	VULB 9168	VULB9168-438	2018.01.18	2Year
Horn Antenna	SCHWARZBECK	BBHA 9120 D	BBHA 9120 D(1201)	2017.01.20	2Year
Cable	Resenberger	N/A	No.1	2017.01.16	1Year
Cable	SCHWARZBECK	N/A	No.2	2017.01.16	1Year
Cable	SCHWARZBECK	N/A	No.3	2017.01.16	1Year
Pre-amplifier	HP	HP8347A	2834A00455	2017.01.18	1Year
Pre-amplifier	Agilent	8449B	3008A02664	2017.01.18	1Year
vector Signal Generator	Agilent	N5182A	MY49060042	2016.11.16	1 Year
vector Signal Generator	Agilent	E4438C	US44271917	2016.11.16	1 Year
X-series USB Peak and Average Power Sensor	Agilent	U2021XA	MY54080020	2016.11.16	1 Year
X-series USB Peak and Average Power Sensor	Agilent	U2021XA	MY54110001	2016.11.16	1 Year
Signal Analyzer	Agilent	N9020A	MY48030494	2016.11.16	1 Year
L.I.S.N.#1	Schwarzbeck	NSLK8126	8126466	2017.01.16	1 Year
L.I.S.N.#2	ROHDE&SCHWARZ	ENV216	101043	2017.01.16	1 Year

### 3. Spurious Emission

#### 3.1. Test Limits

Frequencies (MHz)	Field Strength (micorvolts/meter)	Measurement Distance (meters)
0.009~0.490	2400/F(KHz)	300
0.490~1.705	24000/F(KHz)	30
1.705~30.0	30	30
30~88	100	3
88~216	150	3
216~960	200	3
Above 960	500	3

Harmonic emissions limits comply with below 54 dBuV/m at 3m. Other emissions radiated outside of the specified frequency bands, except for harmonics, shall be attenuated by at least 50 dB below the level of the fundamental or comply with the radiated emissions limits specified in section 15.209(a) limit in the table below has to be followed.

**NOTE:**

- a) The tighter limit applies at the band edges.
- b) Emission Level(dB uV/m)=20log Emission Level(Uv/m)

#### 3.2. Test Procedure

The measuring distance of 3m shall be used for measurements at frequency up to 1GHz and above 1GHz, The EUT was placed on a rotating 0.8 m high above ground, The table was rotated 360 degrees to determine the position of the highest radiation

The Test antenna shall vary between 1m and 4m,Both Horizontal and Vertical antenna are set of make measurement.

The initial step in collecting conducted emission data is a spectrum analyzer Peak detector mode pre-scanning the measurement frequency range. Significant Peaks are then marked. and then Qusia Peak Detector mode premeasured

If Peak value comply with QP limit Below 1GHz.The EUT deemed to comply with QP limit. But the Peak value and average value both need to comply with applicable limit above 1GHz.

For the actual test configuration, please see the test setup photo.

### 3.3. Test Setup

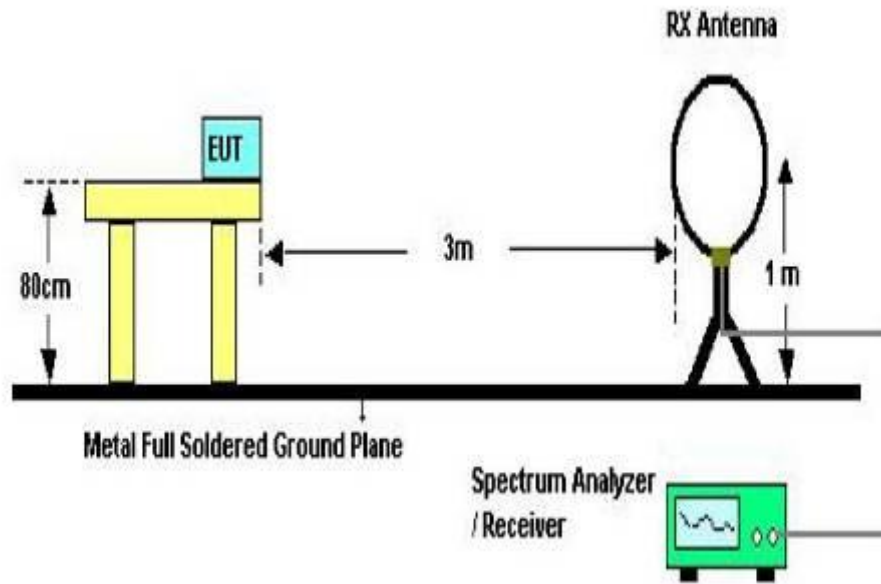

Below 30MHz Test Setup

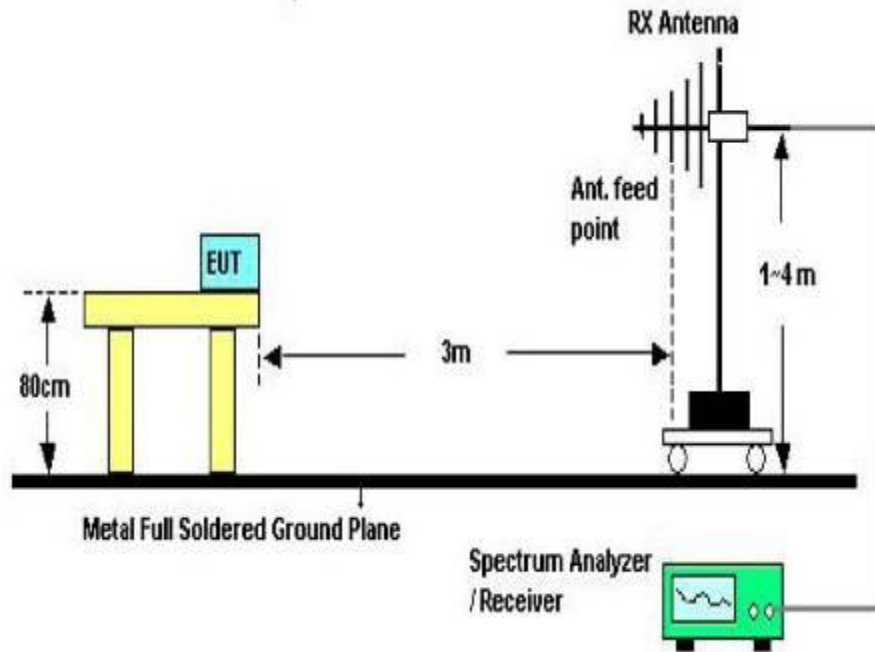

Above 30MHz Test Setup

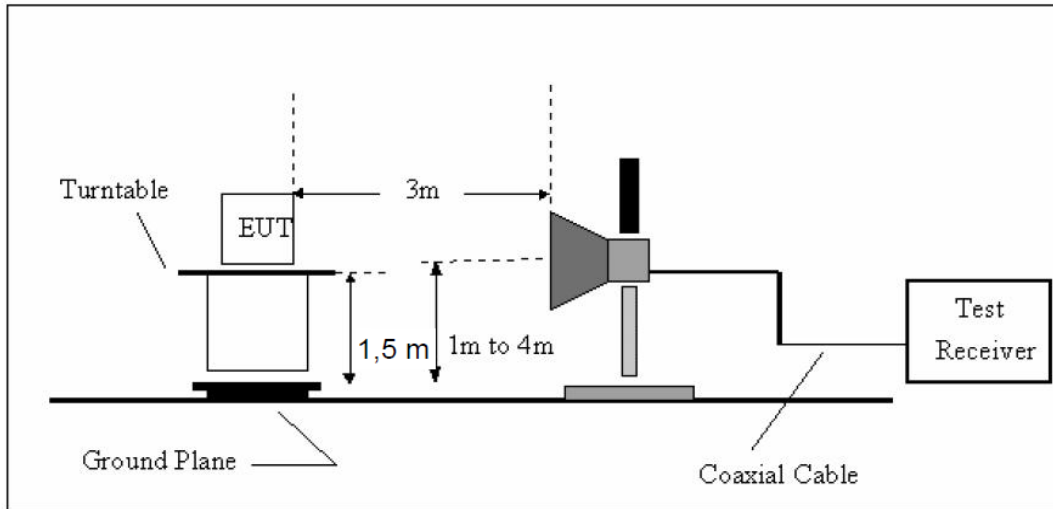

Above 1GHz Test Setup

### 3.4. Test Results

#### Test Condition

Continual Transmitting in maximum power.

9KHz~150KHz	RBW200Hz	VBW1KHz
150KHz~30MHz	RBW9KHz	VBW 30KHz
30MHz~1GHz	RBW120KHz	VBW 300KHz
Above1GHz	RBW1MHz	VBW 3MHz

We have scanned the 10th harmonic from 9 kHz to the EUT.

Detailed information please see the following page.

From 9KHz to 30MHz: Conclusion: PASS

Note:1.The amplitude of spurious emissions which are attenuated by more than 20dB below the permissible value has no need to be reported.

2.Only show the test data of the worst Channel in this report.

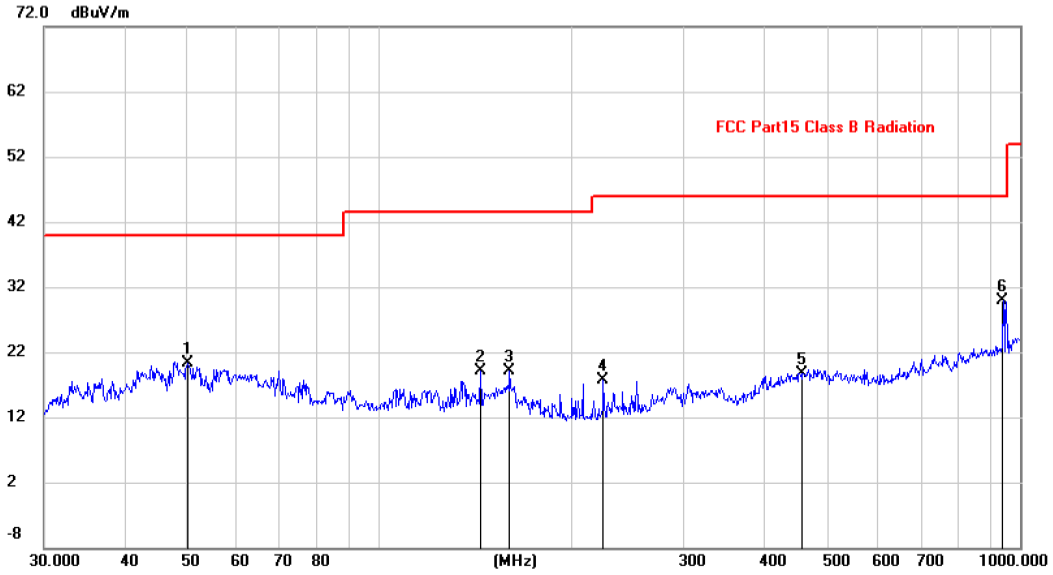

No.	Mk.	Freq.	Reading Level	Correct Factor	Measurement	Limit	Margin	Antenna Height	Table Degree	
		MHz	dBuV	dB	dBuV/m	dBuV/m	dB	cm	degree	Comment
1		50.2324	6.62	13.70	20.32	40.00	-19.68	peak		
2		143.8293	4.97	14.11	19.08	43.50	-24.42	peak		
3		159.7844	4.49	14.58	19.07	43.50	-24.43	peak		
4		224.5192	6.08	11.53	17.61	46.00	-28.39	peak		
5		457.5072	1.70	17.09	18.79	46.00	-27.21	peak		
6	*	942.1304	6.71	23.18	29.89	46.00	-16.11	peak		

Note:1. \*:Maximum data; x:Over limit; !:over margin.

2.Measurement=Reading Level+Correct Factor; Correct Factor=Antenna Factor+Cable Loss.

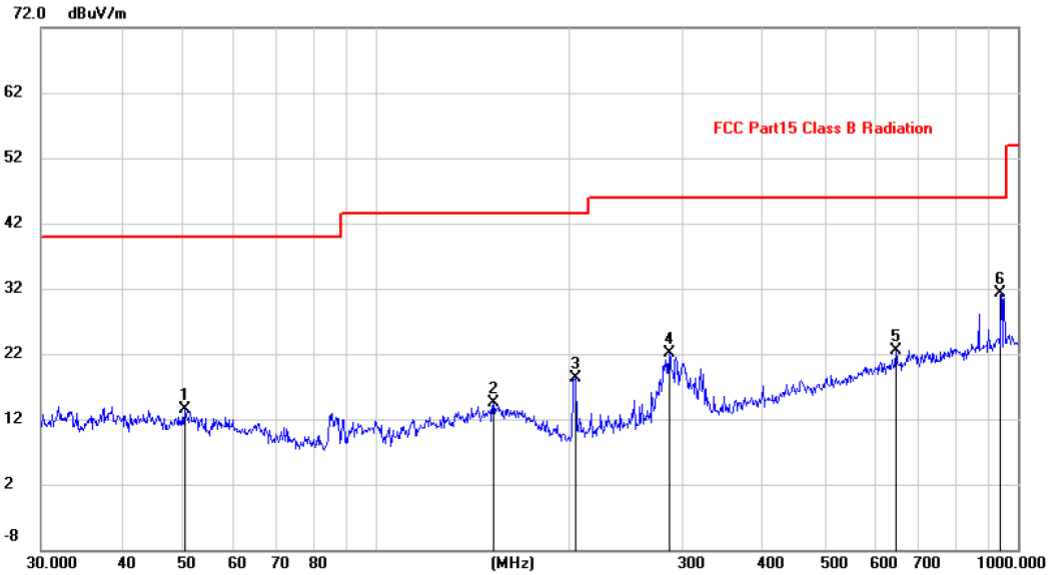

No.	Mk.	Freq.	Reading Level	Correct Factor	Measurement	Limit	Margin	Antenna Height	Table Degree	
		MHz	dBuV	dB	dBuV/m	dBuV/m	dB	cm	degree	Comment
1		50.2324	-0.15	13.70	13.55	40.00	-26.45			peak
2		152.1297	-0.07	14.56	14.49	43.50	-29.01			peak
3		204.2376	7.78	10.48	18.26	43.50	-25.24			peak
4		285.9778	9.06	13.06	22.12	46.00	-23.88			peak
5		645.1195	2.27	20.20	22.47	46.00	-23.53			peak
6	*	942.1304	8.13	23.18	31.31	46.00	-14.69			peak

Note:1. \*:Maximum data; x:Over limit; !:over margin.

2.Measurement=Reading Level+Correct Factor; Correct Factor=Antenna Factor+Cable Loss.

Remark: All modes and channels have been tested and only listed WiFi link mode that is worst data

From 1G-25GHz

Test Mode: IEEE 802.11b TX Low									
Freq (MHz)	Read Level (dBUV/m)	Polar (H/V)	Antenna Factor (dB/m)	Cable loss(dB)	Amp Factor (dB)	Result (dBUV/m)	Limit (dBUV/m)	Margin (dB)	Remark
4824	44.17	V	33.95	10.18	34.26	54.04	74	19.96	PK
4824	34.04	V	33.95	10.18	34.26	43.91	54	10.09	AV
7226									
9648									
4824	42.89	H	33.95	10.18	34.26	52.76	74	21.24	PK
4824	31.67	H	33.95	10.18	34.26	41.54	54	12.46	AV
7226									
9648									
Test Mode: IEEE 802.11b TX Mid									
4874	40.98	V	33.93	10.2	34.29	50.82	74	23.18	PK
4874	32.83	V	33.93	10.2	34.29	42.67	54	11.33	AV
7226									
9648									
4874	41.93	H	33.93	10.2	34.29	51.77	74	22.23	PK
4874	32.62	H	33.93	10.2	34.29	42.46	54	11.54	AV
7226									
9648									
Test Mode: IEEE 802.11b TX High									
4924	42.35		33.98	10.22	34.25	52.30	74	21.70	PK
4924	32.32		33.98	10.22	34.25	42.27	54	11.73	AV
7226									
9648									
4924	42.26		33.98	10.22	34.25	52.21	74	21.79	PK
4924	31.77		33.98	10.22	34.25	41.72	54	12.28	AV
7226									
9648									
Note:									
1, Result = Read level + Antenna factor + cable loss-Amp factor									
2, All the other emissions not reported were too low to read and deemed to comply with FCC limit.									

Test Mode: IEEE 802.11g TX Low									
Freq (MHz)	Read Level (dBuV/m)	Polar (H/V)	Antenna Factor (dB/m)	Cable loss(dB)	Amp Factor (dB)	Result (dBuV/m)	Limit (dBuV/m)	Margin (dB)	Remark
4824	43.45	V	33.95	10.18	34.26	53.32	74	20.68	PK
4824	31.69	V	33.95	10.18	34.26	41.56	54	12.44	AV
7226	/								
9648	/								
4824	43.76	H	33.95	10.18	34.26	53.63	74	20.37	PK
4824	34.41	H	33.95	10.18	34.26	44.28	54	9.72	AV
7226									
9648									
Test Mode: IEEE 802.11g TX Mid									
4874	41.16	V	33.93	10.2	34.29	51.00	74	23.00	PK
4874	33.02	V	33.93	10.2	34.29	42.86	54	11.14	AV
7226	/								
9648	/								
4874	42.15	H	33.93	10.2	34.29	51.99	74	22.01	PK
4874	32.57	H	33.93	10.2	34.29	42.41	54	11.59	AV
7226									
9648									
Test Mode: IEEE 802.11g TX High									
4924	41.76	V	33.98	10.22	34.25	51.71	74	22.29	PK
4924	32.79	V	33.98	10.22	34.25	42.74	54	11.26	AV
7226	/								
9648	/								
4924	41.92	H	33.98	10.22	34.25	51.87	74	22.13	PK
4924	32.31	H	33.98	10.22	34.25	42.26	54	11.74	AV
7226									
9648									
Note:									
1, Result = Read level + Antenna factor + cable loss-Amp factor									
2, All the other emissions not reported were too low to read and deemed to comply with FCC limit.									



Test Mode:IEEE 802.11n HT20 TX Low									
Freq (MHz)	Read Level (dBuV/m)	Polar (H/V)	Antenna Factor (dB/m)	Cable loss(dB)	Amp Factor (dB)	Result (dBuV/m)	Limit (dBuV/m)	Margin (dB)	Remark
4824	44.20	V	33.95	10.18	34.26	54.07	74	19.93	PK
4824	31.38	V	33.95	10.18	34.26	41.25	54	12.75	AV
7226	/								
9648	/								
4824	42.46	H	33.95	10.18	34.26	52.33	74	21.67	PK
4824	32.15	H	33.95	10.18	34.26	42.02	54	11.98	AV
7226									
9648									
Test Mode:IEEE 802.11n HT20 TX Mid									
4874	41.51	V	33.93	10.2	34.29	51.35	74	22.65	PK
4874	32.47	V	33.93	10.2	34.29	42.31	54	11.69	AV
7226	/								
9648	/								
4874	41.44	H	33.93	10.2	34.29	51.28	74	22.72	PK
4874	32.29	H	33.93	10.2	34.29	42.13	54	11.87	AV
7226									
9648									
Test Mode:IEEE 802.11n HT20 TX High									
4924	42.08	V	33.98	10.22	34.25	52.03	74	21.97	PK
4924	32.33	V	33.98	10.22	34.25	42.28	54	11.72	AV
7226	/								
9648	/								
4924	41.92	H	33.98	10.22	34.25	51.87	74	22.13	PK
4924	32.31	H	33.98	10.22	34.25	42.26	54	11.74	AV
7226									
9648									
Note:									
1, Result = Read level + Antenna factor + cable loss-Amp factor									
2, All the other emissions not reported were too low to read and deemed to comply with FCC limit.									

## 4. Power line Conducted Emission

### 4.1. Test Limits

Frequency MHz	Limits dB( $\mu$ V)	
	Quasi-peak Level	Average Level
0.15 -0.50	66 -56*	56 - 46*
0.50 -5.00	56	46
5.00 -30.00	60	50

- Notes: 1. \*Decreasing linearly with logarithm of frequency.  
 2. The lower limit shall apply at the transition frequencies.  
 3. The limit decreases in line with the logarithm of the frequency in the range of 0.15 to 0.50 MHz.

### 4.2. Test Procedure

The EUT is put on the plane 0.8m high above the ground by insulating support and is connected to the power mains through a line impedance stabilization network (L.I.S.N.). This provides a 50ohm coupling impedance for the EUT system. Please refer the block diagram of the test setup and photographs. Both sides of AC lines are checked to find out the maximum conducted emission. In order to find the maximum emission levels, the relative positions of equipment and all of the interface cables shall be changed according to ANSI C63.4:2014 on Conducted Emission Measurement.

The bandwidth of test receiver is set at 9 kHz.

### 4.3. Test Setup

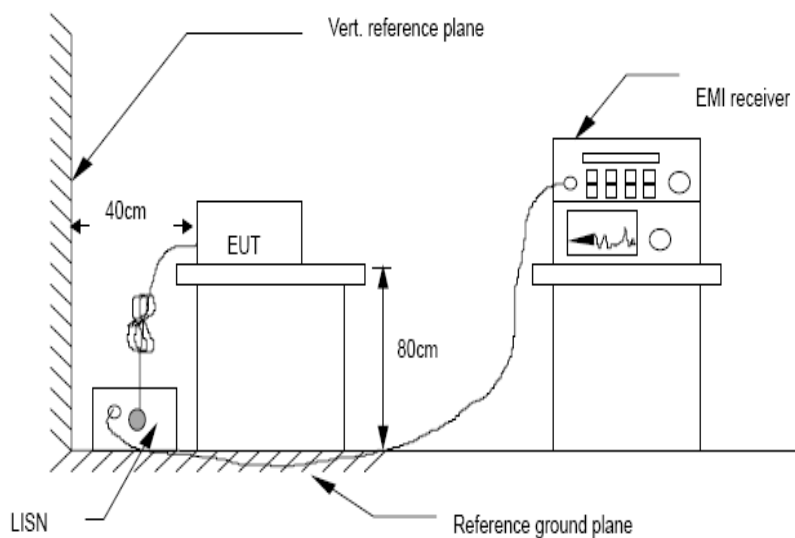

### 4.4. Test Results

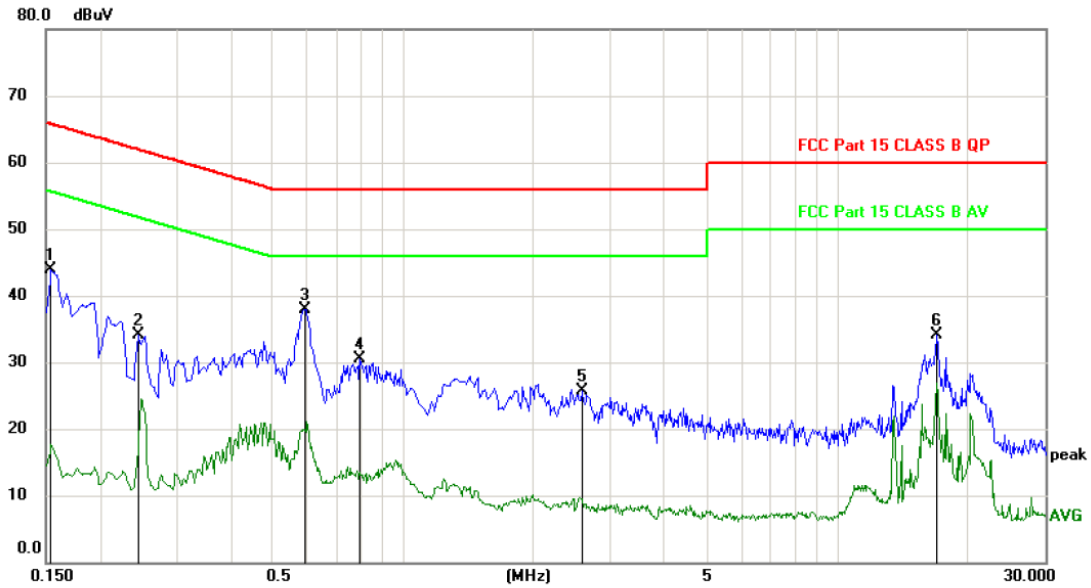

No.	Mk.	Freq. MHz	Reading Level dBuV	Correct Factor dB	Measure- ment dBuV	Limit dBuV	Margin dB	Detector	Comment
1		0.1545	34.13	9.73	43.86	65.75	-21.89	peak	
2		0.2445	24.31	9.76	34.07	61.94	-27.87	peak	
3	*	0.5910	28.07	9.79	37.86	56.00	-18.14	peak	
4		0.7935	20.76	9.81	30.57	56.00	-25.43	peak	
5		2.5805	15.71	10.01	25.72	56.00	-30.28	peak	
6		16.9005	23.62	10.46	34.08	60.00	-25.92	peak	

\*:Maximum data    x:Over limit    !:over margin

<Reference Only

Note: Measurement=Reading Level+Correc Factor.    Factor=(LISN or ISN or PLC or Current Probe)Factor+Cable

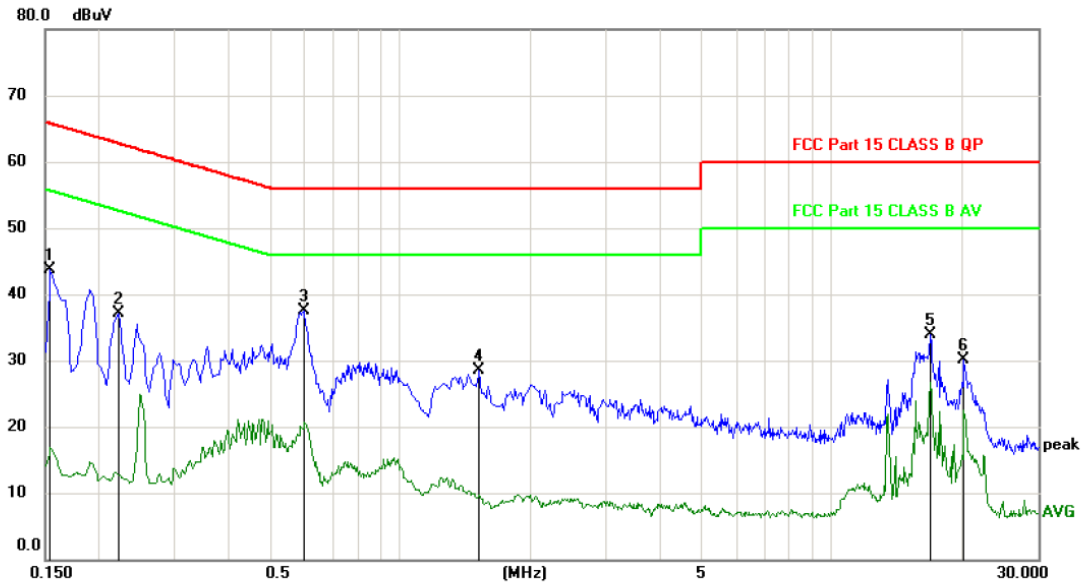

No.	Mk.	Freq. MHz	Reading Level dBuV	Correct Factor dB	Measure- ment dBuV	Limit dBuV	Margin dB	Detector	Comment
1		0.1545	33.99	9.73	43.72	65.75	-22.03	peak	
2		0.2220	27.29	9.75	37.04	62.74	-25.70	peak	
3	*	0.5955	27.63	9.79	37.42	56.00	-18.58	peak	
4		1.5205	18.54	9.88	28.42	56.00	-27.58	peak	
5		16.9005	23.44	10.46	33.90	60.00	-26.10	peak	
6		20.2605	19.57	10.52	30.09	60.00	-29.91	peak	

\*:Maximum data    x:Over limit    !:over margin

⟨Reference Only

Note: Measurement=Reading Level+Correc Factor.    Factor=(LISN or ISN or PLC or Current Probe)Factor+Cable

Remark: All modes and channels have been tested and only listed WiFi link mode that is worst data

## 5 Conducted Maximum Output Power

### 5.1 Test limits

Please refer section 15.247.

Regulation 15.247(b) The limit of Maximum Peak Output Power Measurement is 1 W(30dBm)

### 5.2 Test Procedure

Details see the KDB558074 D01 Meas Guidance V04

5.2.1 Place the EUT on the table and set it in transmitting mode.

5.2.2 Connected the EUT's antenna port to peak power meter by 20dB attenuator.

5.2.3 Measure out each mode and each bands peak output power of EUT.

Note: The cable loss and attenuator loss were offset into measure device as amplitude offset.

### 5.3 Test Setup

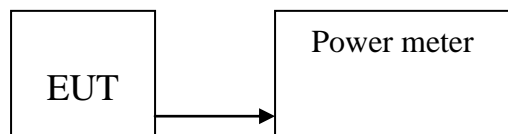

### 5.4 Test Results

PASS

Detailed information please see the following page.

Mode	Frequency (MHz)	Ant Port	PK Output power(dBm)		Limit (dBm)	Margin (dB)
IEEE 802.11 b	CH1: 2412	0	6.289	6.289	30	23.71
		1	/			
	CH6: 2437	0	6.184	6.184	30	23.82
		1	/			
	CH11: 2462	0	6.241	6.241	30	23.76
		1	/			
IEEE 802.11 g	CH1: 2412	0	5.739	5.739	30	24.26
		1	/			
	CH6: 2437	0	4.834	4.834	30	25.17
		1	/			
	CH11: 2462	0	5.250	5.250	30	24.75
		1	/			
IEEE 802.11 n/HT20 with 2.4G	CH1: 2412	0	4.775	4.775	30	25.23
		1	/			
	CH6: 2437	0	4.134	4.134	30	25.87
		1	/			
	CH11: 2462	0	4.962	4.962	30	25.04
		1	/			
Conclusion: PASS						

## 6 Peak Power Spectral Density

### 6.1 Test limits

6.1.1 Please refer section 15.247.

6.1.2 For direct sequence systems, the peak power spectral density conducted from the intentional radiator to the antenna shall not be greater than 8dBm in any 3kHz band during any time interval of continuous transmission.

6.1.3 The direct sequence operating of the hybrid system, with the frequency hopping operation turned off, shall comply with the power density requirements of paragraph (d) of this section.

### 6.2 Test Procedure

Details see the KDB558074 D01 Meas Guidance V04

6.2.1 Place the EUT on the table and set it in transmitting mode.

6.2.2 Remove the antenna from the EUT and then connect a low loss RF cable from the antenna port to the spectrum analyzer.

6.2.3 Set the spectrum analyzer as RBW = 3kHz, VBW = 10kHz, span=5-30%EBW, detail see the test plot.

6.2.4 Record the max reading.

6.2.5 Repeat the above procedure until the measurements for all frequencies are completed.

### 6.3 Test Setup

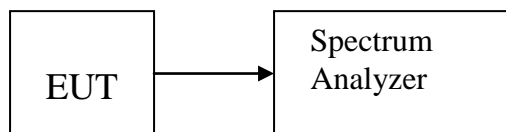

## 6.4 Test Results

Mode	Frequency (MHz)	Ant Port	PK Output power(dBm)		Limit (dBm)	Result
IEEE 802.11 b	CH1: 2412	0	-10.766	-10.766	8	PASS
		1	/			
	CH6: 2437	0	-9.897	-9.897	8	PASS
		1	/			
	CH11: 2462	0	-10.704	-10.704	8	PASS
		1	/			
IEEE 802.11 g	CH1: 2412	0	-14.299	-14.299	8	PASS
		1	/			
	CH6: 2437	0	-12.359	-12.359	8	PASS
		1	/			
	CH11: 2462	0	-12.579	-12.579	8	PASS
		1	/			
IEEE 802.11 n/HT20 with 2.4G	CH1: 2412	0	-13.205	-13.205	8	PASS
		1	/			
	CH6: 2437	0	-13.604	-13.604	8	PASS
		1	/			
	CH11: 2462	0	-13.572	-13.572	8	PASS
		1	/			
Conclusion: PASS						



IEEE 802.11b :  
CH Low :

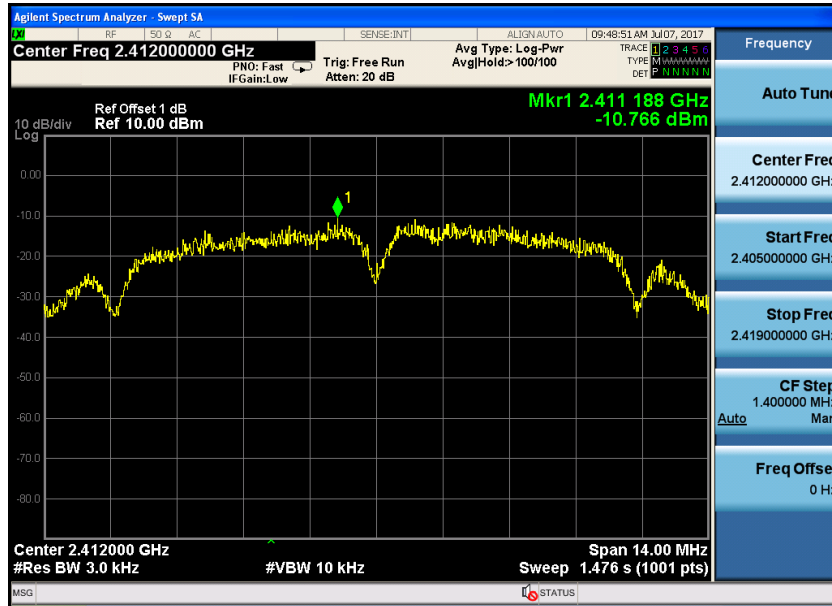

CH Mid:

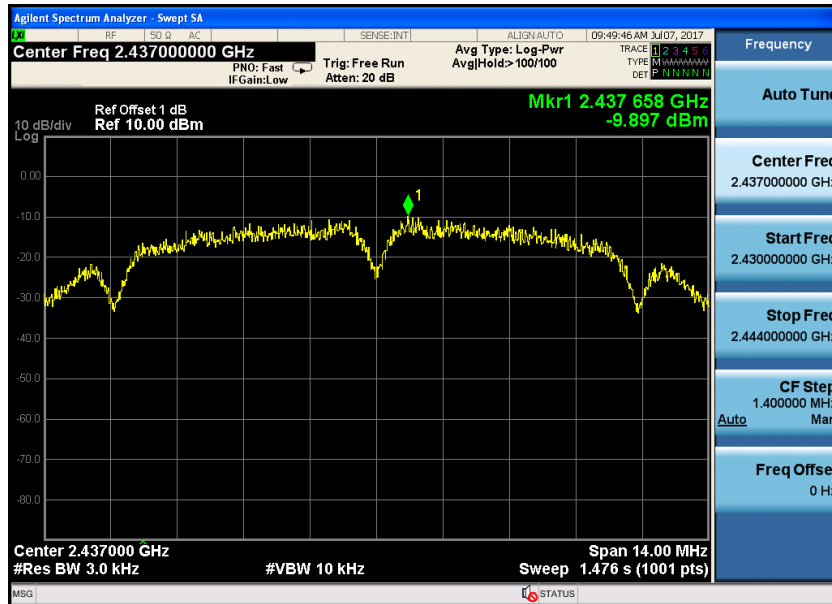

CH Hig:

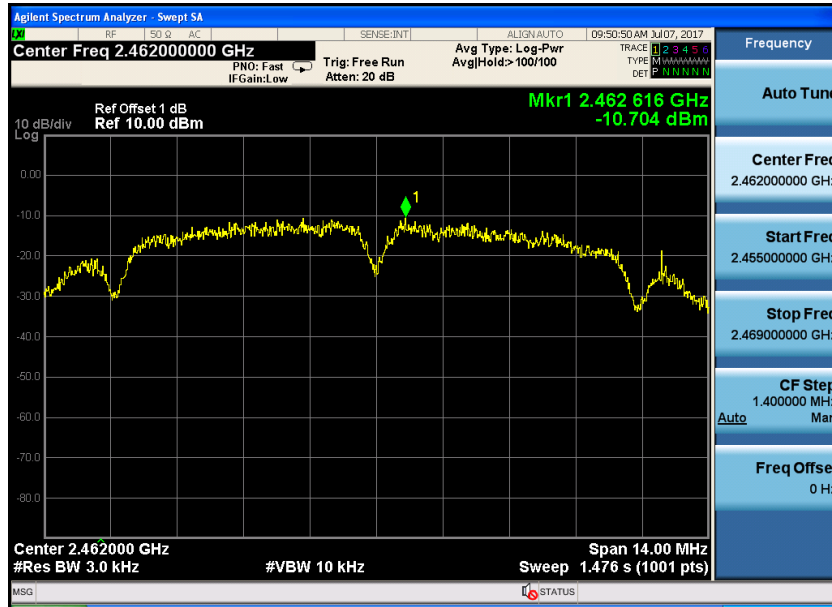

IEEE 802.11g :  
CH Low

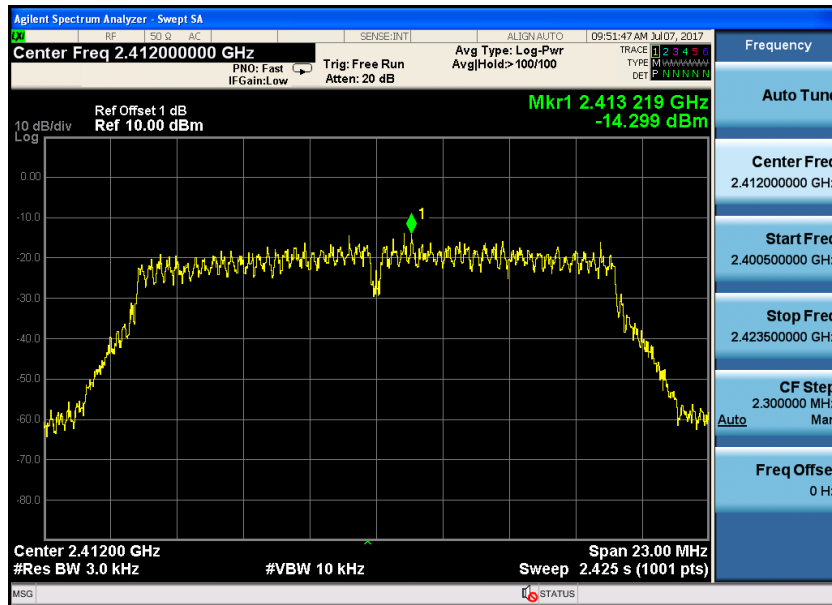

CH Mid:

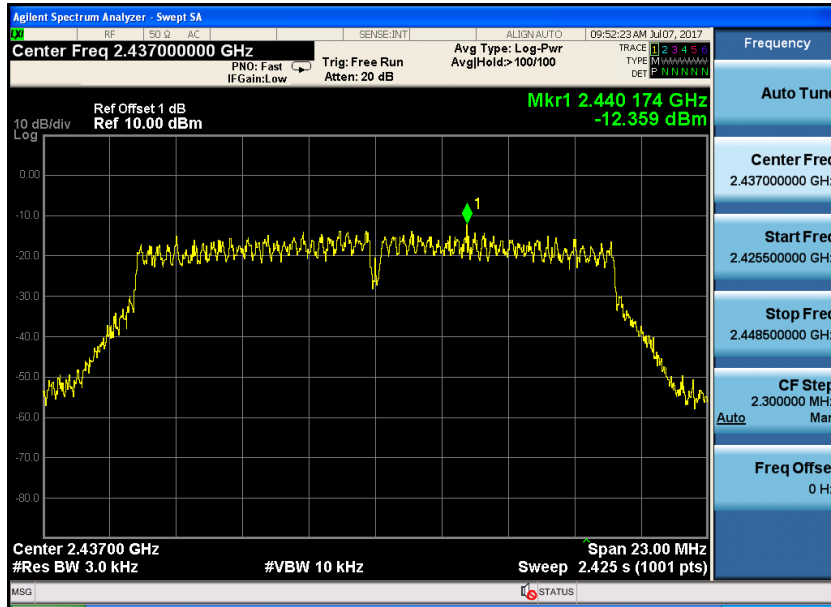

CH High:

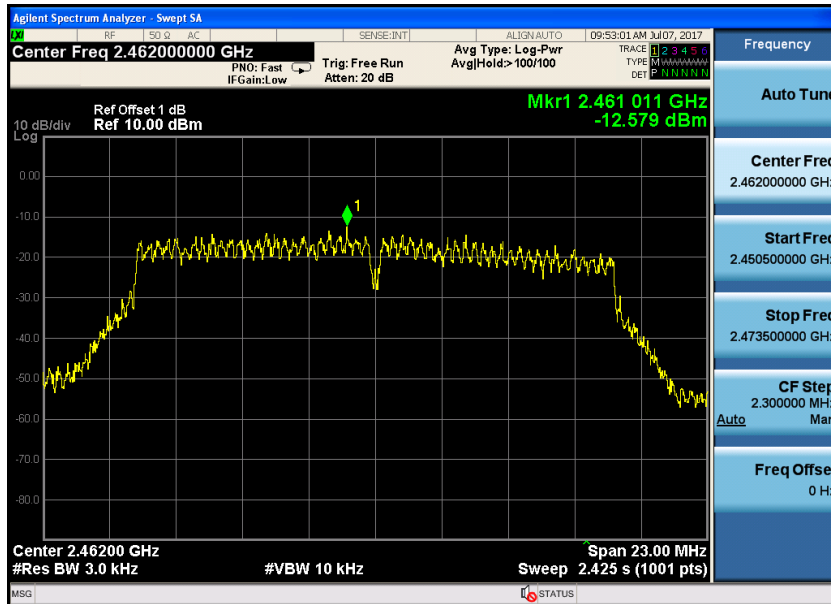

IEEE 802.11n HT20 :  
CH Low :

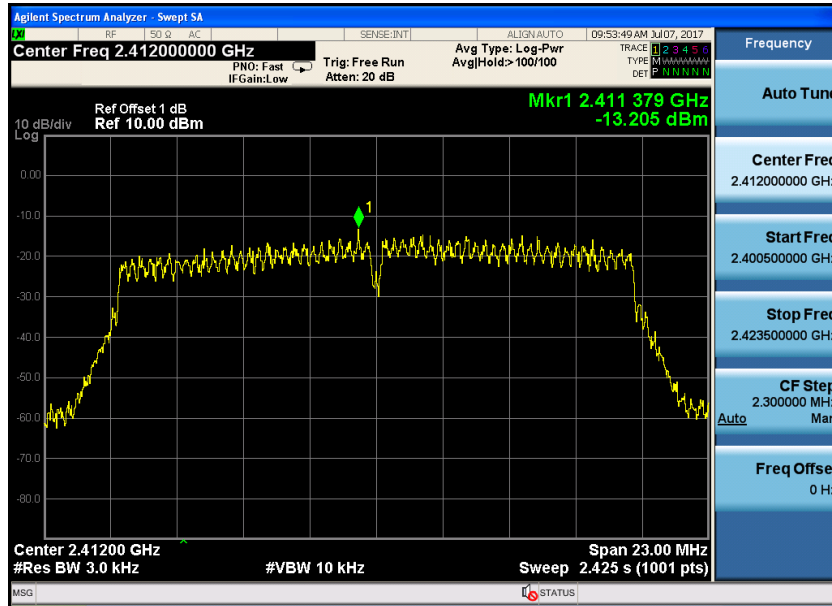

CH Mid:

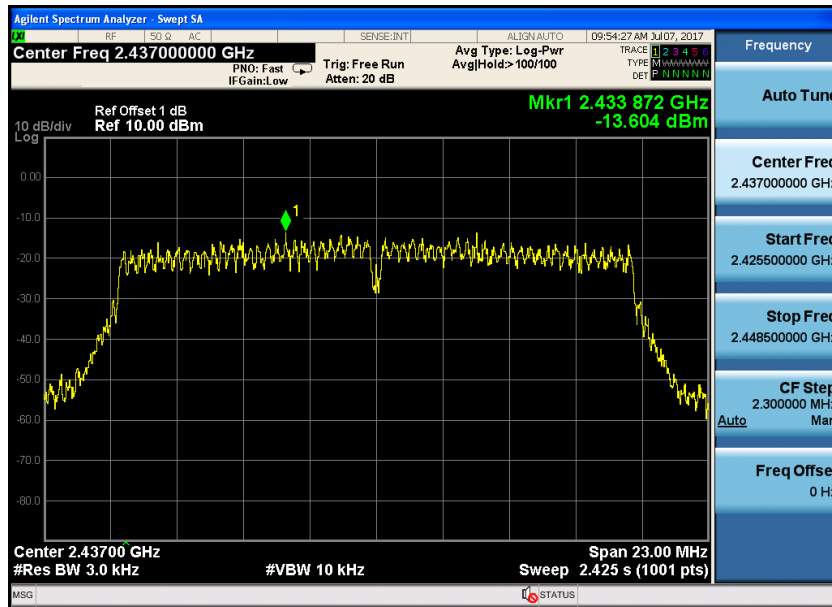

CH High:

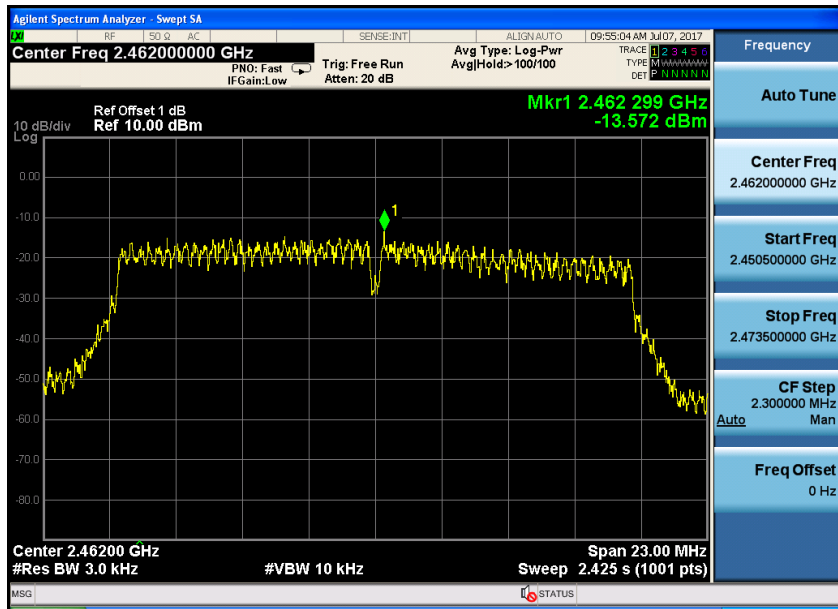

## 7 Bandwidth

### 7.1 Test limits

Please refer section 15.247

For direct sequence systems, the minimum 6dB bandwidth shall be at least 500 kHz.

### 7.2 Test Procedure

Details see the KDB558074 D01 Meas Guidance V04

- a) The bandwidth is measured at an amplitude level reduced 20dB from the reference level. The reference level is the level of the highest amplitude signal observed from the transmitter at the fundamental frequency. Once the reference level is established, the equipment is conditioned with typical modulating signal to produce the worst-case (i.e. the widest) bandwidth.
- b) The test receiver set RBW = 1-5 % EBW, VBW  $\geq$  3RBW, Peak Detector, Sweep time set auto, detail see the test plot.

### 7.3 Test Setup

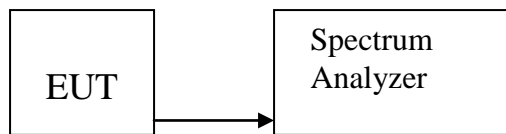

### 7.4 Test Results

Channel	Frequency (MHz)	6dB Bandwidth (MHz)	99% Occupied Bandwidth (MHz)	Limit (MHz)	Result
IEEE 802.11b:					
Low	2412	9.096	13.693	0.5	PASS
Mid	2437	9.108	13.842	0.5	PASS
High	2462	9.562	13.895	0.5	PASS
IEEE 802.11g					
Low	2412	15.17	16.379	0.5	PASS
Mid	2437	15.17	16.387	0.5	PASS
High	2462	15.32	16.393	0.5	PASS
IEEE 802.11n/HT20					
Low	2412	15.17	17.545	0.5	PASS
Mid	2437	15.17	17.548	0.5	PASS
High	2462	15.35	17.546	0.5	PASS

IEEE 802.11b:  
CH Low :

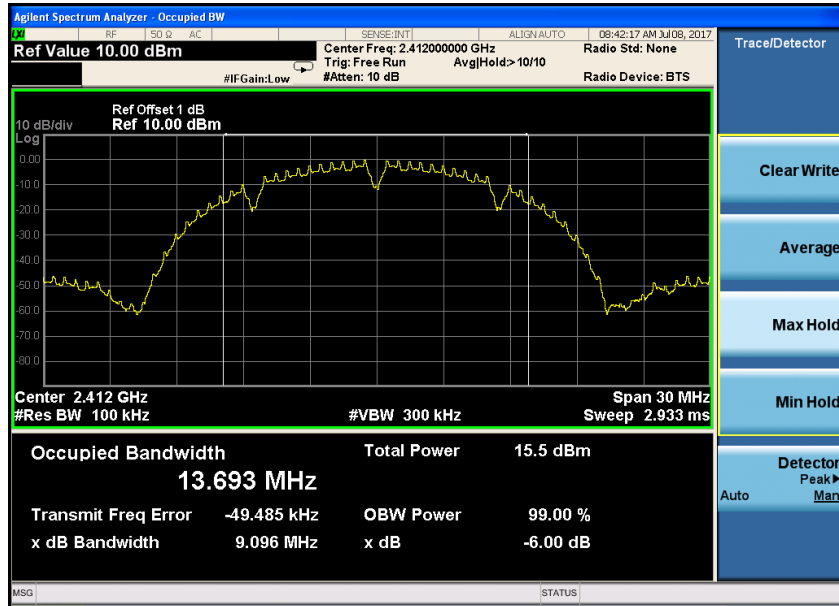

CH Mid :

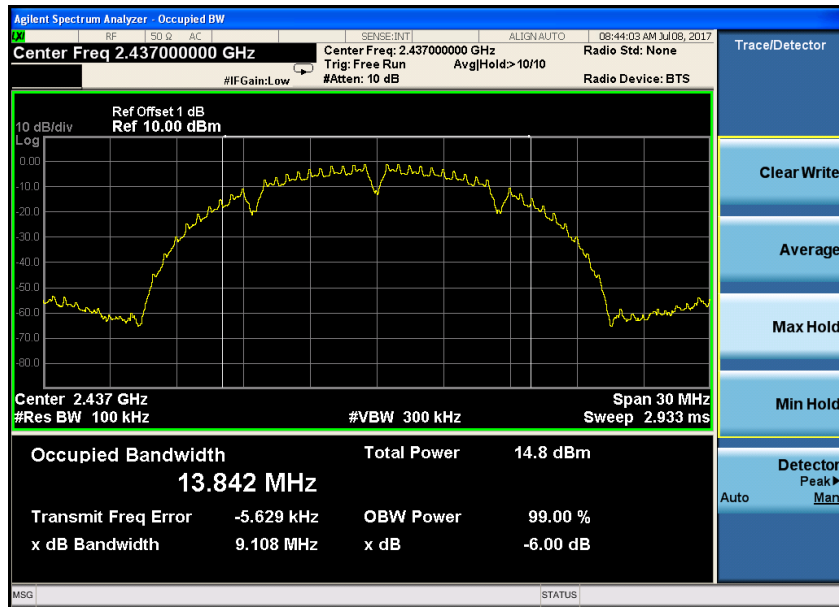

CH High :

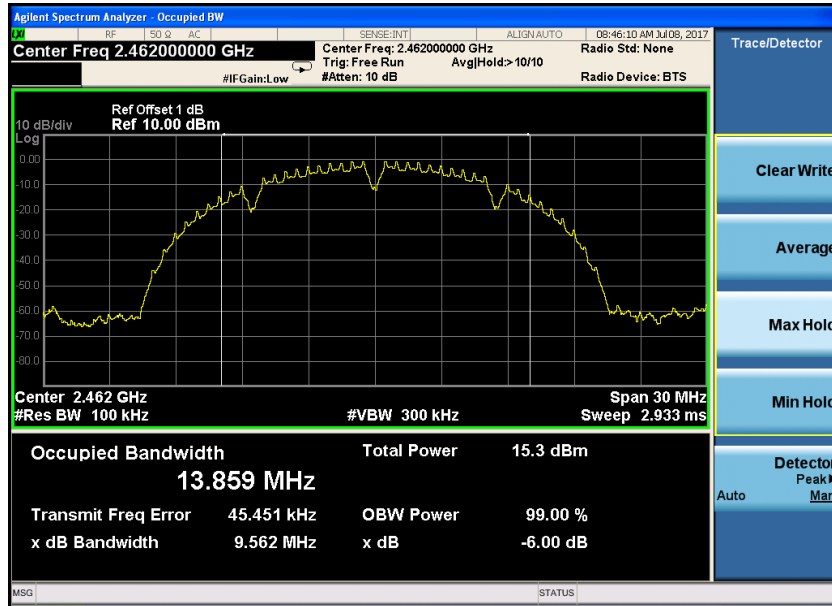

IEEE 802.11g:  
CH Low :

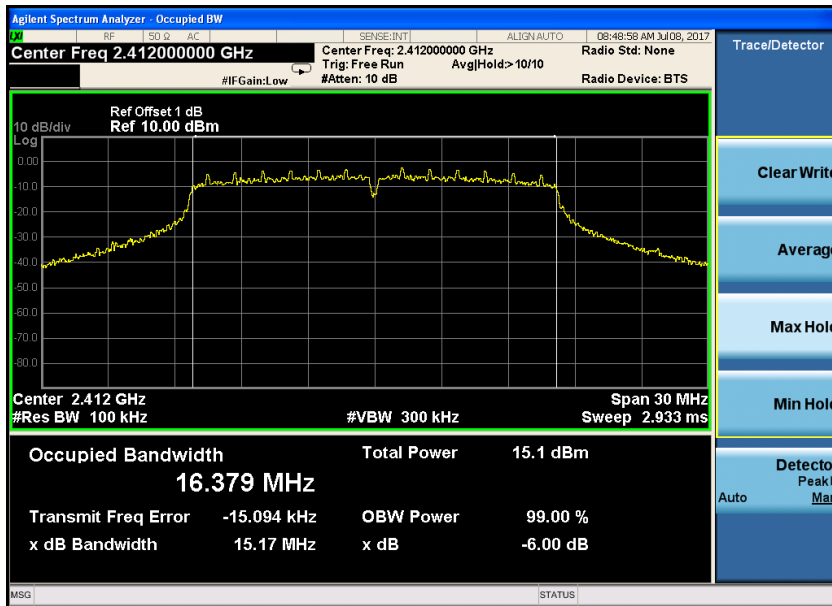



CH Mid:

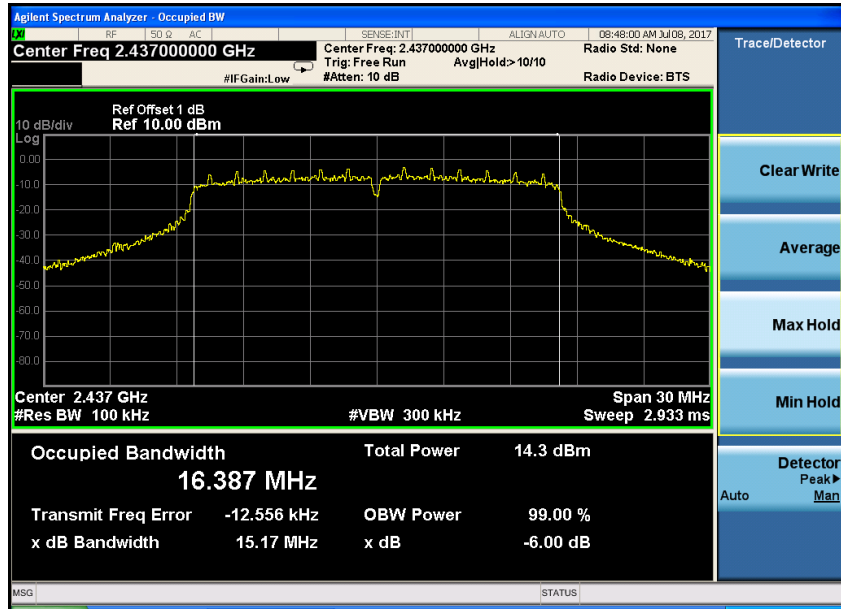

CH High

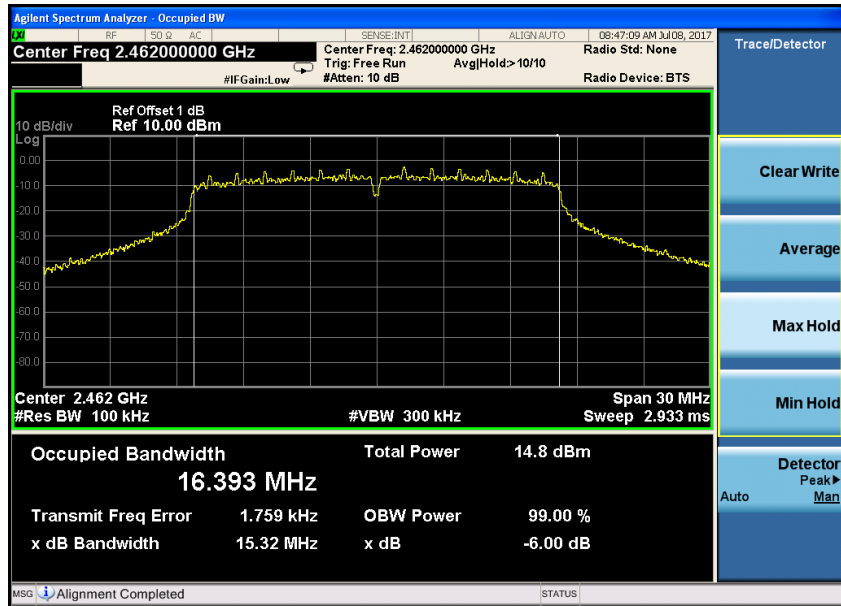

IEEE 802.11n HT20:  
CH Low :

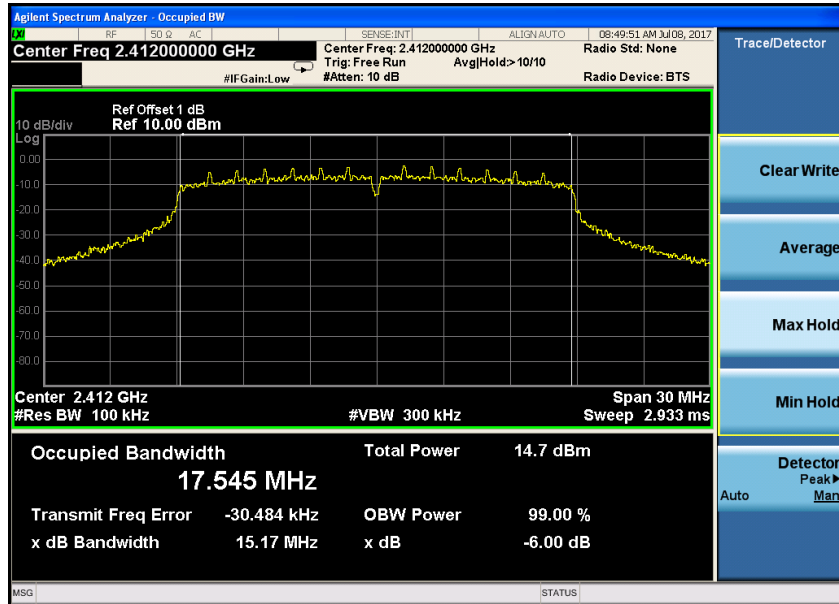

CH Mid :

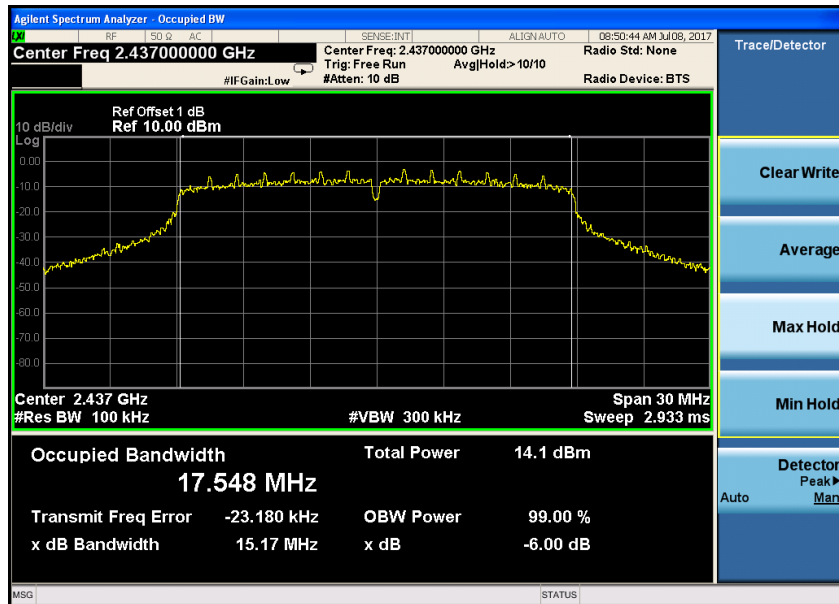

CH High :

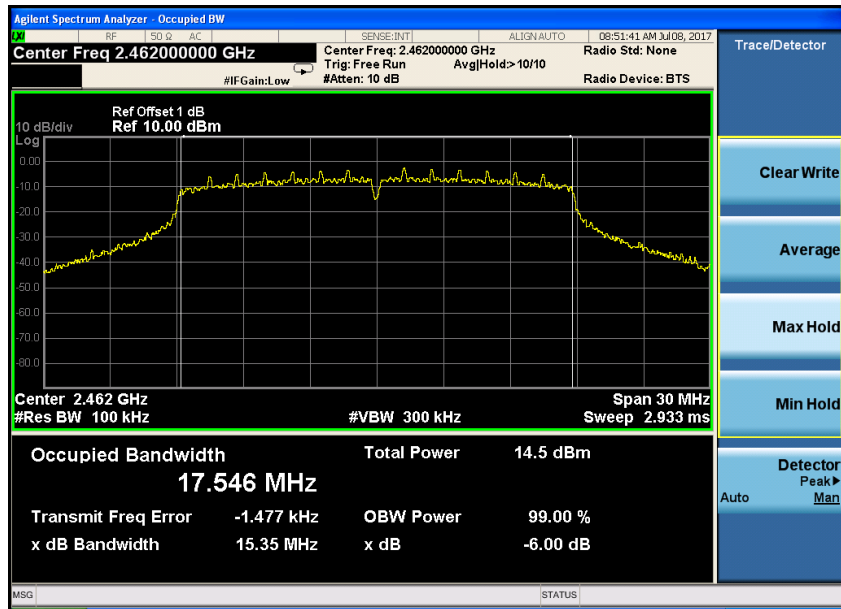

## 8 Band Edge Check

### 8.1 Test limits

Please refer section 15.247

All the lower and upper band-edges emissions appearing within 2310MHz to 2390MHz and 2483.5MHz to 2500MHz restricted frequency bands shall not exceed the limits shown in 15.209, all the other emissions outside operation frequency band 2400MHz to 2483.5MHz and 5725MHz to 5850MHz shall be at least 20dB below the fundamental emissions, or comply with 15.209 limits.

### 8.2 Test Procedure

Details see the KDB558074 D01 Meas Guidance V04

8.2.1 Put the EUT on a 0.8m high table, power on the EUT. Emissions were scanned and measured rotating the EUT to 360 degrees, Find the maximum Emission

8.2.2 Check the spurious emissions out of band.

8.2.3 RBW 1MHz, VBW 3MHz, peak detector for peak value , RBW 1MHz ,VBW 3MHz , RMS detector for AV value.

### 8.3 Test Setup

Same as 5.2.2.

### 8.4 Test Results

PASS.

Detailed information please see the following page.

## Radiated Method:

Test mode: IEEE 802.11b TX LOW									
Freq (MHz)	Read Level (dBuV/m)	Polar (H/V)	Antenna Factor (dB/m)	Cable loss(dB)	Amp Factor (dB)	Result (dBuV/m)	Limit (dBuV/m)	Margin (dB)	Remark
2390	54.58	V	27.62	3.92	34.97	51.15	74	22.85	PK
2390	--	V	27.62	3.94	34.97	--	54	--	AV
2390	54.09	H	27.62	3.92	34.97	50.66	74	23.34	PK
2390	--	H	27.62	3.94	34.97	--	54	--	AV
Test mode: IEEE 802.11b TX High									
2483.5	54.37	V	27.89	4	34.97	51.29	74	22.71	PK
2483.5	--	V	27.89	4	34.97	--	54	--	AV
2483.5	54.63	H	27.89	4	34.97	51.55	74	22.45	PK
2483.5	--	H	27.89	4	34.97	--	54	--	AV
Test mode: IEEE 802.11g TX LOW									
2390	54.25	V	27.62	3.92	34.97	50.82	74	23.18	PK
2390	--	V	27.62	3.92	34.97	--	54	--	AV
2390	54.16	H	27.62	3.92	34.97	50.73	74	23.27	PK
2390	--	H	27.62	3.92	34.97	--	54	--	AV
Test mode: IEEE 802.11g TX High									
2483.5	54.50	V	27.89	4	34.97	51.42	74	22.58	PK
2483.5		V	--	--	--	--	54	--	AV
2483.5	54.22	H	27.89	4	34.97	51.14	74	22.86	PK
2483.5	--	H	--	--	--	--	54	--	AV
Test mode: IEEE 802.11n HT20TX LOW									
2390	54.00	V	27.62	3.92	34.97	50.57	74	23.43	PK
2390	--	V	27.62	3.92	34.97	--	54	--	AV
2390	54.26	H	27.62	3.92	34.97	50.83	74	23.17	PK
2390	--	H	27.62	3.92	34.97	--	54	--	AV
Test mode: IEEE 802.11n HT20TX High									
2483.5	53.71	V	27.89	4	34.97	50.63	74	23.37	PK
2483.5		V	--	--	--	--	54	--	AV
2483.5	54.31	H	27.89	4	34.97	51.23	74	22.77	PK
2483.5		H	--	--	--	--	54	--	AV

## Note:

- 1, Result = Read level + Antenna factor + cable loss-Amp factor
- 2, All the other emissions not reported were too low to read and deemed to comply with FCC limit.

802.11b

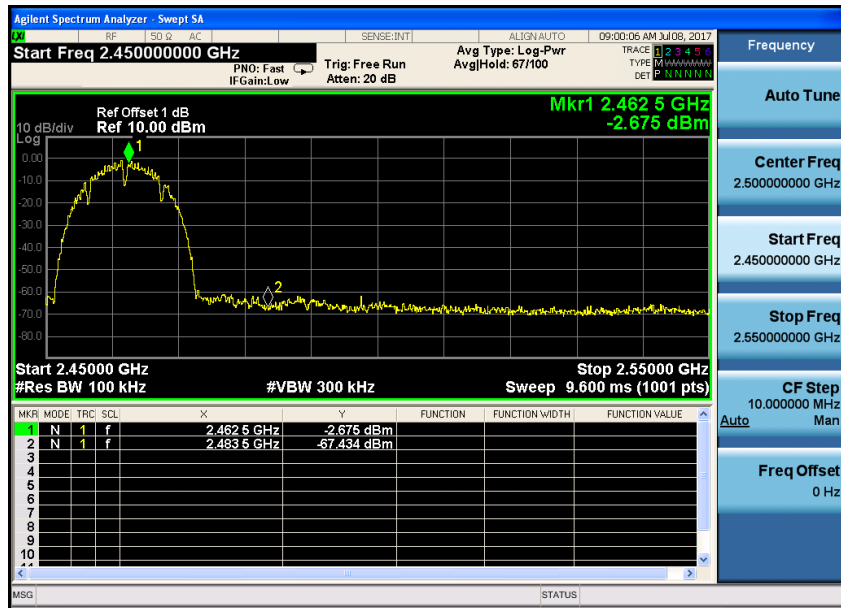
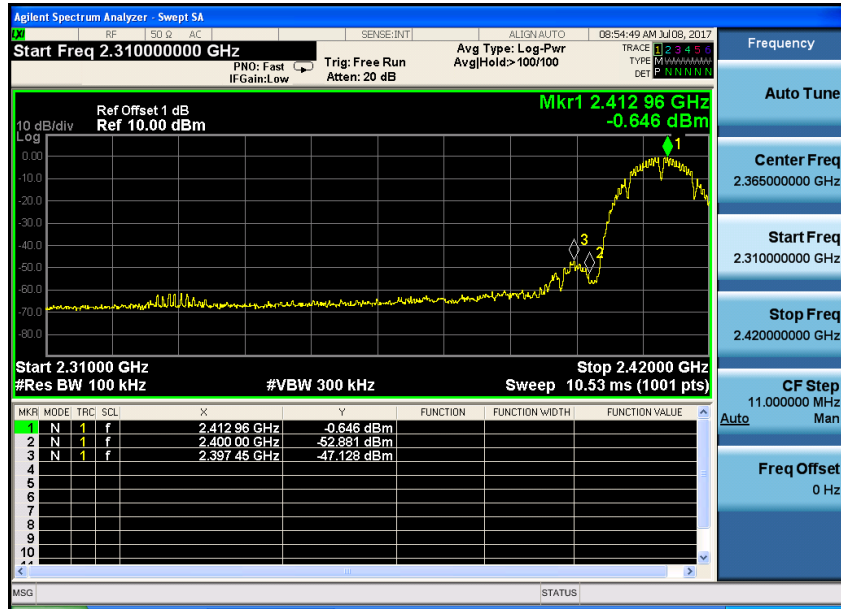

802.11g

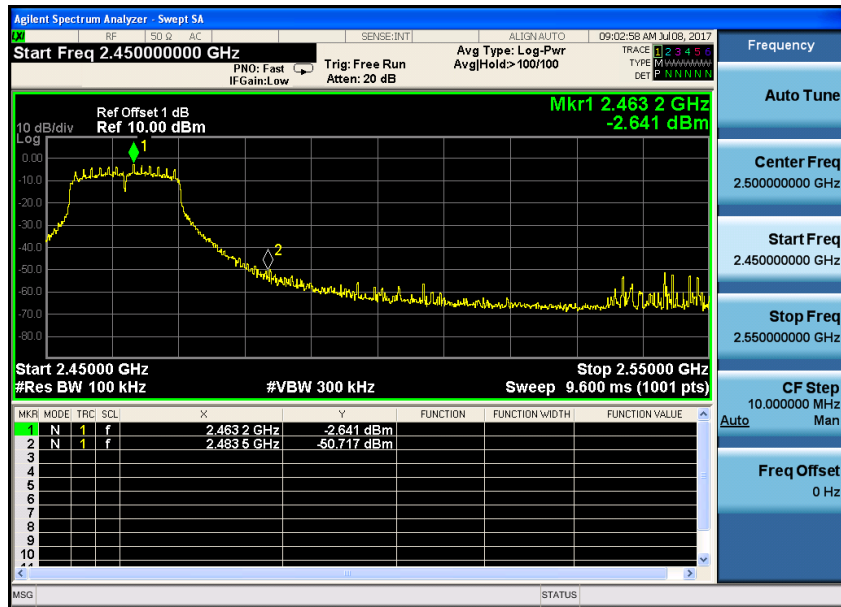
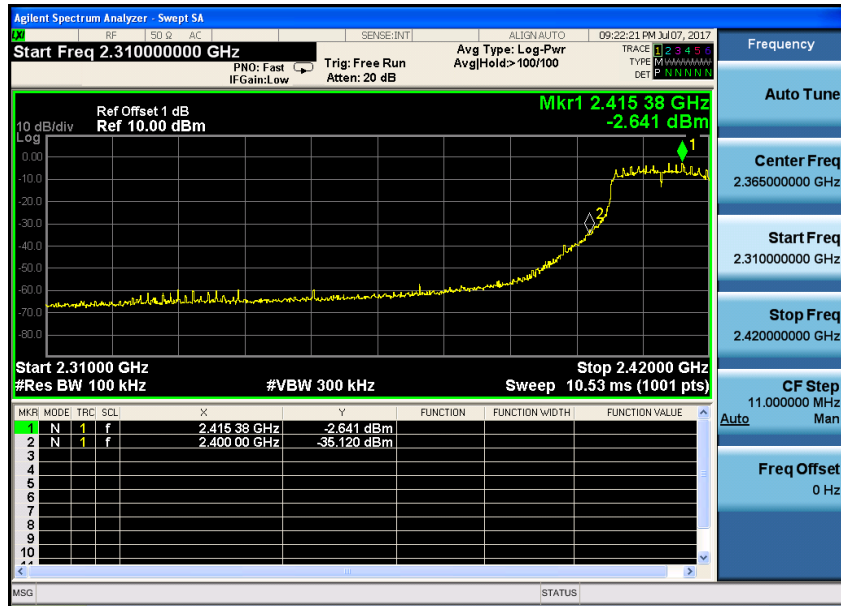

802.11n HT20

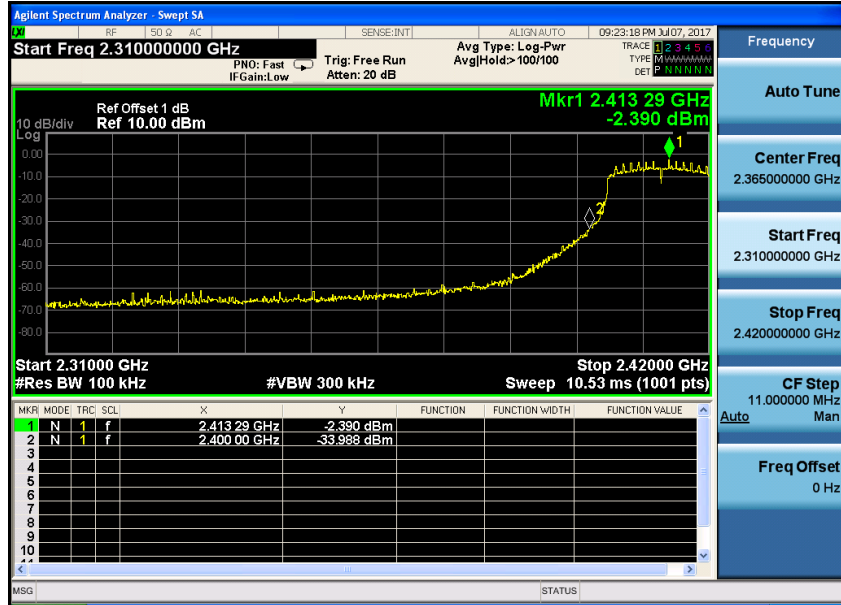



## **9 Antenna Requirement**

### **9.1 Standard Requirement**

An intentional radiator shall be designed to ensure that no antenna other than that furnished by the responsible party shall be used with the device. The use of a permanently attached antenna or of an antenna that uses a unique coupling to the intentional radiator shall be considered sufficient to comply with the provisions of this Section. The manufacturer may design the unit so that a broken antenna can be replaced by the user, but the use of a standard antenna jack or electrical connector is prohibited.

### **9.2 Antenna Connected Construction**

The antenna connector is unique antenna and no consideration of replacement. Please see EUT photo for details.

### **9.3 Results**

The EUT antenna is PCB Antenna. It comply with the standard requirement.

**-----THE END OF REPORT-----**