

Acknowledgment Letter



SPECIFICATION FOR APPROVAL

CUSTOMER: **Shenzhen Yixunda Technology Co., Ltd**CUST P/N: **10.0110.1988**FINE P/N: **Watch transmission coil 7.6UH 0.08 * 30P * 12TS**

DESC:

DATE: **May 23, 2024**

Version:

A.0

PREPARED BY	CHECKED BY	APPROVED BY	CUSTOMER APPROVE
Huang Yanming	Ning Yuan'an	Huang Yanming	

Dongguan Xilian Gancheng Technology Co., Ltd

Factory address: 8th floor, Building 2, Sanjia High tech Industrial Park, No.
123 Junfa Road, Dongkeng Town, Dongguan City

TEL: 0769-82989159

FAX: 0769-82989159

E-mail: aming198204@163.com

SPECIFICATION

DESC	Apple launch coil 15 * 21.5-7.6UH-25MM	Rev: A.0	CUST:	XXX
			CUST P/N:	

one、DIMENSION:(mm)

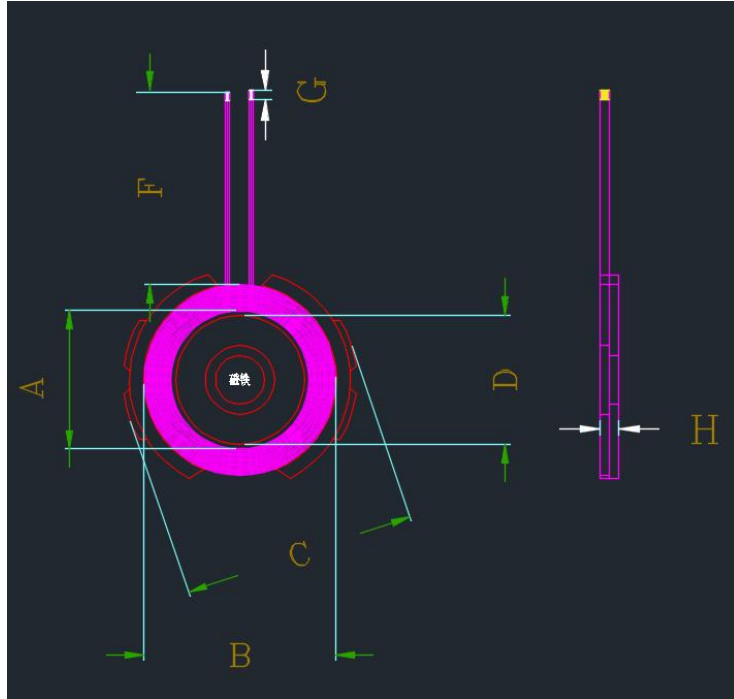

A	15±0.5
B	21.5±0.5
C	25±1
D	13.5±0.0.5
F	25±2
H	2.8±0.5

Note:

1. Cross outgoing line;
2. Wrap mm (ref) wide high-temperature adhesive paper Ts around the outlet position;
3. The coil is covered with circular hard magnetic plates with notches at both ends, with a magnetic plate size of 25 ± 1mm, an inner hole of 7.7mm, and a thickness of 2.8 ± 0.2mm.
4. Add N52 strong magnetic field in the middle

two、SCHEMATIC DIAGRAM:

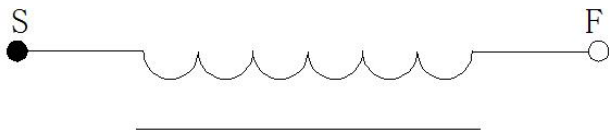

three、Winding Specification:

NO.	TERMINAL	WIRE	Turns	Winding Direction
1	S F	Enamel wire 0.08 * 30P	12Ts	CCW

four、ELECTRICAL CHARACTERISTICS:

TEMPERATURE:25±10°C, RELATIVE HUMIDITY:65±20%

NO.	ITEM	TERMINAL	SPECIFICATION	TEST FREQUENCY	TEST EQUIPMENTS
1	IND.	S-F	3.8uH ± 20% individual coil	100KHz/1.0V	LCZ METER 1062B
2	IND.	S-F	7.6uH ± 10% individual coil	100KHz/1.0V	LCZ METER 1062B
3	DCR	S-F	≤100m Ω	100KHz/1.0V	LCZ METER 502B
4	Q	S-F	≥39	100KHz/1.0V	LCZ METER 502B

PREPARED BY/DATE	CHECKED BY/DATE
Huang Yanming May 23, 202	Huang Jinhua May 23, 2024