

承认书

SPECIFICATION FOR APPROVAL

客户名称 : 深圳市博泰盛华科技有限公司

CUSTOMER'S NAME

客户料号 : 40403005

CUSTOMER'S P/N

产品规格 : Y. WAC. 058

PRODUCT SPEC

制作日期 : 2023年9月7日

ISSUE DATE

拟制 PREPARED BY	审核 CHECKED BY	批准 APPROVED BY	客户承认 CUSTOMER APPROVE
李蓓	程杰	李博文	



东莞市博红科技有限公司

DONGGUAN BOHONG TECHNOLOGY CO., LTD

ADD: 东莞市大朗镇富民中路533号4楼

TEL: 0769-82866410

FAX: 0769-82866409

本承认书请在首批下单生产此机种前回签, 否则视为贵方默认此承认书内所有内容

东莞市博红科技有限公司

DONGGUAN BOHONG TECHNOLOGY CO., LTD

SPECIFICATION FOR APPROVAL



CUSTOMER	博泰盛华	CUSTOMER'S P/N	40403005
ISSUE DATE	2023年9月7日	PRODUCT SPEC	Y. WAC. 058

2.DIMENSION:

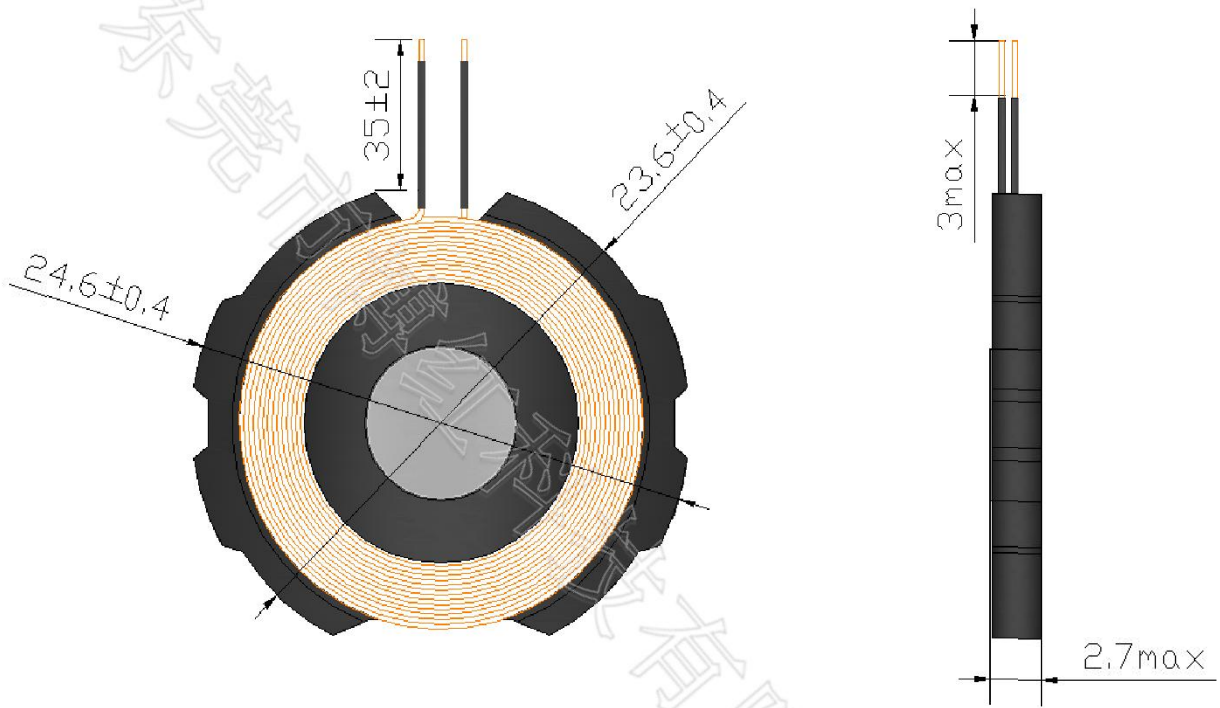

注:

- 背面贴皇冠#513双面胶;
- 磁铁7.5*2.0mm高斯3200, “S”极朝上;
- 出线不交叉;

ISSUE BY	李蓓	CHECK BY	程杰	APPROVAL BY	李博文
----------	----	----------	----	-------------	-----

东莞市博红科技有限公司

DONGGUAN BOHONG TECHNOLOGY CO., LTD

SPECIFICATION FOR APPROVAL

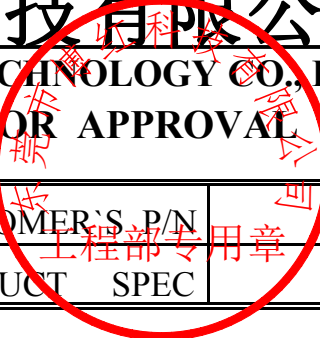

CUSTOMER	博泰盛华	CUSTOMER'S P/N	40403005
ISSUE DATE	2023年9月7日	PRODUCT SPEC	Y. WAC. 058

4. CIRCUIT DIAGRAM

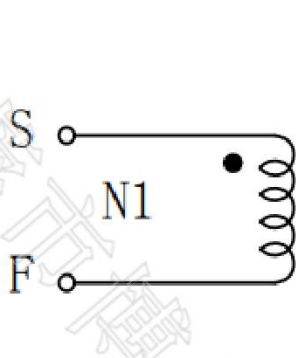

" • " : POLARITY/极性

5. WINDING

NO	WINDING	WIRE	TURNS	TAPE	WINDING CONDITION
N1	S-F	Ø0.08*24P	14	/	CCW

6. CHARACTERISTIC

ITEM	MEASURED POINT	TECHNICAL DATA	TESTING CONDITION & INSTRUMENT
LS	S-F	8.1uH±5%	LCR1062 100KHz/1V AT 25°C±2°C
Q	S-F	27±5	LCR1062 100KHz/1V AT 25°C±2°C

东莞市博红科技有限公司

DONGGUAN BOHONG TECHNOLOGY CO., LTD

SPECIFICATION FOR APPROVAL



CUSTOMER	博泰盛华	CUSTOMER'S P/N	40403005
ISSUE DATE	2023年9月7日	PRODUCT SPEC	Y. WAC. 058

7. THE PACKING WAY

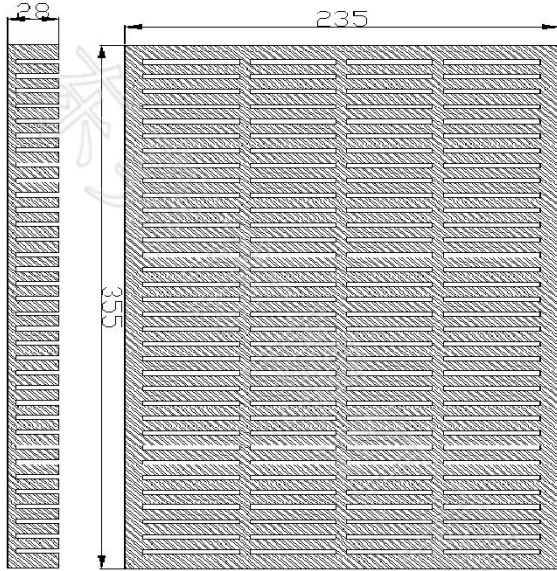

- 1. 珍珠棉规格: 355*235*28mm*136格;
- 2. 每格装2pcs, 每盘272pcs;
- 3. 每箱装10盘;
- 4. 每箱合计: 2720pcs;
- 5. 纸箱材质: K=K++;

侧面图

俯视图

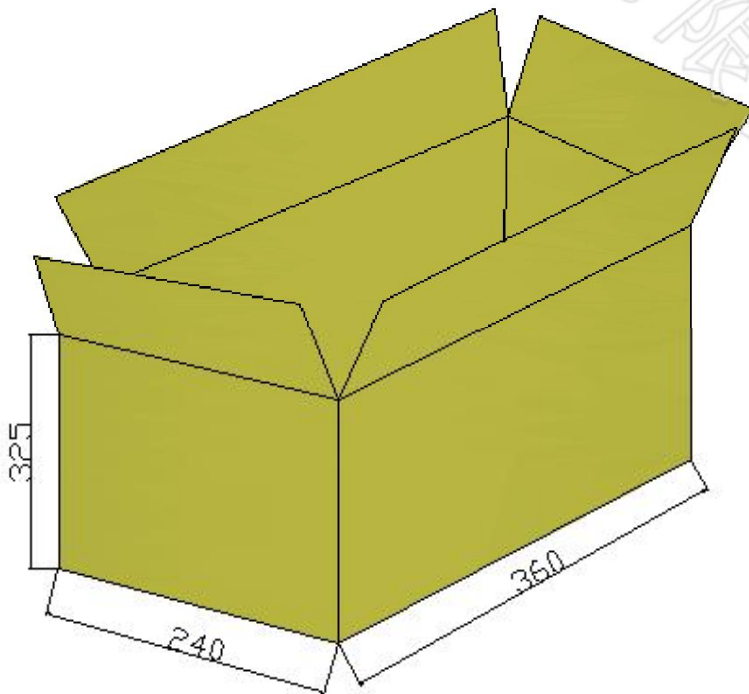

东莞市博红科技有限公司

DONGGUAN BOHONG TECHNOLOGY CO., LTD

SPECIFICATION FOR APPROVAL



CUSTOMER	博泰盛华	CUSTOMER'S P/N	40403005
ISSUE DATE	2023年9月7日	PRODUCT SPEC	Y.WAC.058

备忘录

序号	内 容	处理方法	签 名	日 期
1				
2				
3				
4				
5				
6				
7				
8				
9				
10				