



Valued Quality. Delivered.

## TEST REPORT

**Report No.: 17031690HKG-001**

**Sphero HK Limited**

Application  
For  
Class II Permissive Change

**(FCC ID: SXO-SP001)**

Transceiver

This report contains the data of Bluetooth 4.0 portion only.

Prepared and Checked by:

Approved by:

Signed On File  
Yao Xin Lu, Josie  
Engineer

---

Koo Wai Ip  
Technical Supervisor  
Date: April 27, 2017

- Intertek's standard Terms and Conditions can be obtained at our website <http://www.intertek.com/terms/>.
- The test report only allows to be revised within the retention period unless further standard or the requirement was noticed.
- This report is for the exclusive use of Intertek's Client and is provided pursuant to the agreement between Intertek and its Client. Intertek's responsibility and liability are limited to the terms and conditions of the agreement. Intertek assumes no liability to any party, other than to the Client in accordance with the agreement, for any loss, expense or damage occasioned by the use of this report. Only the Client is authorized to permit copying or distribution of this report and then only in its entirety. Any use of the Intertek name or one of its marks for the sale or advertisement of the tested material, product or service must first be approved in writing by Intertek. The observations and test results in this report are relevant only to the sample tested. This report by itself does not imply that the material, product, or service is or has ever been under an Intertek certification program.
- © 2016 Intertek

**Intertek Testing Services Hong Kong Ltd.**

2/F., Garment Centre, 576 Castle Peak Road, Kowloon, Hong Kong.  
Tel: (852) 2173 8888 Fax: (852) 2785 5487 Website: [www.hk.intertek-eltsemko.com](http://www.hk.intertek-eltsemko.com)

## INTERTEK TESTING SERVICES

---

### GENERAL INFORMATION

Grantee:	Sphero HK Limited
Grantee Address:	4/F., 299 QRC, 287-299, Queen's Road Central, Sheung Wan, Hong Kong.
Contact Person:	Jackal Ma
Tel:	+852 97887164
Fax:	N/A
e-mail:	N/A
Manufacturer:	Sphero, Inc.
Manufacturer Address:	4772 Walnut Street, Suite 206, Boulder, CO 80301, USA
Brand Name:	Sphero
Model:	SP001
Type of EUT:	Transceiver
Description of EUT:	Spider-Man Interactive App-Enabled Super Hero
Serial Number:	N/A
FCC ID:	SXO-SP001
Date of Sample Submitted:	March 29, 2017
Date of Test:	March 29, 2017 to April 22, 2017
Report No.:	17031690HKG-001
Report Date:	April 27, 2017
Environmental Conditions:	Temperature: +10 to 40°C Humidity: 10 to 90%

## INTERTEK TESTING SERVICES

---

### SUMMARY OF TEST RESULT

TEST SPECIFICATION	REFERENCE	RESULTS
Transmitter Power Line Conducted Emissions	15.207	Pass
Radiated Emission Radiated Emission on the Bandedge	15.249, 15.209	Pass
Radiated Emission in Restricted Bands	15.205	Pass

The equipment under test is found to be complying with the following standards:  
FCC Part 15, October 1, 2015 Edition

- Note: 1. The EUT uses a permanently attached antenna which, in accordance to section 15.203, is considered sufficient to comply with the provisions of this section.
2. Pursuant to FCC part 15 Section 15.215(c), the 20 dB bandwidth of the emission was contained within the frequency band designated (mentioned as above) which the EUT operated. The effects, if any, from frequency sweeping, frequency hopping, other modulation techniques and frequency stability over excepted variations in temperature and supply voltage were considered.

---

# INTERTEK TESTING SERVICES

---

## Table of Contents

1.0	<b><u>General Description</u></b> .....	1
1.1	Product Description .....	1
1.2	Purpose of Change.....	1
1.3	Test Methodology .....	2
1.4	Test Facility .....	2
2.0	<b><u>System Test Configuration</u></b> .....	3
2.1	Justification.....	3
2.2	EUT Exercising Software .....	3
2.3	Special Accessories.....	3
2.4	Measurement Uncertainty .....	3
2.5	Support Equipment List and Description.....	3
3.0	<b><u>Emission Results</u></b> .....	4
3.1	Field Strength Calculation .....	4
3.2	Radiated Emission Configuration Photograph .....	5
3.3	Radiated Emission Data .....	5
3.4	Conducted Emission Configuration Photograph.....	5
3.5	Conducted Emission Data.....	5
4.0	<b><u>Equipment Photographs</u></b> .....	11
5.0	<b><u>Product Labelling</u></b> .....	11
6.0	<b><u>Technical Specifications</u></b> .....	11
7.0	<b><u>Instruction Manual</u></b> .....	11
8.0	<b><u>Miscellaneous Information</u></b> .....	12
8.1	Measured Bandwidth / Radiated Emission on the Bandedge.....	12
8.2	Discussion of Pulse Desensitization .....	15
8.3	Calculation of Average Factor .....	15
8.4	Emissions Test Procedures .....	17
9.0	<b><u>Confidentiality Request</u></b> .....	20
10.0	<b><u>Equipment List</u></b> .....	21

# INTERTEK TESTING SERVICES

---

## 1.0 General Description

### 1.1 Product Description

The Equipment-Under-Test (EUT) is a Wireless Spiderman toy. The EUT contains both WLAN (WiFi) and Bluetooth (Bluetooth 4.0) modules. It has sound and light during normal play. An iOS/Android app installed in Smartphone can connect with the EUT via Bluetooth and Wifi. The EUT is powered by a 3.7VDC rechargeable battery and be charged by the computer with a USB charging cable.

#### For the WLAN (WiFi) module:

The Equipment Under Test (EUT) operates at frequency range of 2412MHz to 2462MHz with 11 channels. For 802.11g mode, it operates at frequency range of 2412.000MHz to 2462.000MHz with 11 channels. It transmits via Orthogonal Frequency Division Multiplexing (OFDM) modulation. Maximum bit rate can be up to 54Mbps. For 802.11n (with 20MHz bandwidth) mode, it operates at frequency range of 2412.000MHz to 2462.000MHz with 11 channels. It transmits via Orthogonal Frequency Division Multiplexing (OFDM) modulation. Maximum bit rate can support up to 65Mbps. For 802.11n (with 40MHz bandwidth) mode, it operates at frequency range of 2422.000MHz to 2452.000MHz with 11 channels. It transmits via Orthogonal Frequency Division Multiplexing (OFDM) modulation. Maximum bit rate can support up to 65Mbps.

#### For Bluetooth module:

For Bluetooth 4.0 BLE mode, it occupies a frequency range from 2402MHz to 2480MHz (40 channels with channel spacing of 2MHz). It transmits via GFSK modulation.

Antenna Type: Internal, Integral

For electronic filing, the brief circuit description is saved with filename: descri.pdf.

### 1.2 Purpose of Change

The purpose of change is saved with filename: product change.pdf

## INTERTEK TESTING SERVICES

---

### 1.3 Test Methodology

Both AC mains line-conducted and radiated emission measurements were performed according to the procedures in ANSI C63.10 (2013). All radiated measurements were performed in an 3m Chamber. Preliminary scans were performed in the 3m Chamber only to determine worst case modes. All radiated tests were performed at an antenna to EUT distance of 3 meters, unless stated otherwise in the “**Justification Section**” of this Application.

### 1.4 Test Facility

The 3m Chamber and conducted measurement facility used to collect the radiated data is located at Workshop No. 3, G/F., World-Wide Industrial Centre, 43-47 Shan Mei Street, Fo Tan, Sha Tin, N.T., Hong Kong. This test facility and site measurement data have been placed on file with the FCC.

## INTERTEK TESTING SERVICES

---

### 2.0 System Test Configuration

#### 2.1 Justification

The system was configured for testing in a typical fashion (as a customer would normally use it), and in the confines as outlined in ANSI C63.10 (2013).

The device was powered by new 3.7V rechargeable battery.

For maximizing emissions, the EUT was rotated through 360°, the antenna height was varied from 1 meter to 4 meters above the ground plane, and the antenna polarization was changed. This step by step procedure for maximizing emissions led to the data reported in Exhibit 3.0.

The unit was operated standalone and placed in the center of the turntable. The equipment under test (EUT) was configured for testing in a typical fashion (as a customer would normally use it). The EUT was mounted to a plastic stand if necessary and placed on the wooden turntable, which enabled the engineer to maximize emissions through its placement in the three orthogonal axes.

For simultaneous transmission, both WiFi and Bluetooth portions are also switched on when taking radiated emission for determining worst-case spurious emission.

#### 2.2 EUT Exercising Software

The EUT exercise program (if any) used during radiated and conducted testing was designed to exercise the various system components in a manner similar to a typical use.

#### 2.3 Special Accessories

There are no special accessories necessary for compliance of this product.

#### 2.4 Measurement Uncertainty

When determining of the test conclusion, the Measurement Uncertainty of test has been considered.

Uncertainty and Compliance - Unless the standard specifically states that measured values are to be extended by the measurement uncertainty in determining compliance, all compliance determinations are based on the actual measured value.

#### 2.5 Support Equipment List and Description

1. USB charging cable with length of 1 meter long. (Provided by Client)
2. Notebook (HP Probook 430) (Provided by Intertek)
3. iPod Touch (Provided by Client)
4. Charging stand (Provided by Client)

## INTERTEK TESTING SERVICES

---

### 3.0 Emission Results

Data is included of the worst case configuration (the configuration which resulted in the highest emission levels). A sample calculation, configuration photographs and data tables of the emissions are included.

#### 3.1 Field Strength Calculation

The field strength is calculated by adding the Antenna Factor and Cable Factor, and subtracting the Amplifier Gain (if any), Average Factor (optional) from the measured reading. The basic equation with a sample calculation is as follows:

$$FS = RA + AF + CF - AG - AV$$

where

- FS = Field Strength in dB $\mu$ V/m
- RA = Receiver Amplitude (including preamplifier) in dB $\mu$ V
- CF = Cable Attenuation Factor in dB
- AF = Antenna Factor in dB
- AG = Amplifier Gain in dB
- AV = Average Factor in dB

In the following table(s), the reading shown on the data table reflects the preamplifier gain. An example for the calculations in the following table is as follows:

$$FS = RR + LF$$

where

- FS = Field Strength in dB $\mu$ V/m
- RR = RA - AG - AV in dB $\mu$ V
- LF = CF + AF in dB

Assume a receiver reading of 52.0 dB $\mu$ V is obtained. The antenna factor of 7.4 dB and cable factor of 1.6 dB are added. The amplifier gain of 29 dB and average factor of 5 dB are subtracted, giving a field strength of 27 dB $\mu$ V/m. This value in dB $\mu$ V/m was converted to its corresponding level in  $\mu$ V/m.

$$\begin{aligned} RA &= 52.0 \text{ dB}\mu\text{V/m} \\ AF &= 7.4 \text{ dB} & RR &= 18.0 \text{ dB}\mu\text{V} \\ CF &= 1.6 \text{ dB} & LF &= 9.0 \text{ dB} \\ AG &= 29.0 \text{ dB} \\ AV &= 5.0 \text{ dB} \\ FS &= RR + LF \\ FS &= 18 + 9 = 27 \text{ dB}\mu\text{V/m} \end{aligned}$$

$$\text{Level in } \mu\text{V/m} = \text{Common Antilogarithm } [(27 \text{ dB}\mu\text{V/m})/20] = 22.4 \mu\text{V/m}$$



## INTERTEK TESTING SERVICES

---

### 3.2 Radiated Emission Configuration Photograph

The worst case in radiated emission was found at 201.569 MHz

For electronic filing, the worst case radiated emission configuration photographs are saved with filename: radiated photos.pdf.

### 3.3 Radiated Emission Data

The data on the following page lists the significant emission frequencies, the limit and the margin of compliance. Numbers with a minus sign are below the limit.

Judgment: Passed by 1.00 dB

### 3.4 Conducted Emission Configuration Photograph

The worst case in line-conducted emission was found at 172.5 kHz

For electronic filing, the worst case line-conducted configuration photographs are saved with filename: conducted photo.pdf.

### 3.5 Conducted Emission Data

For electronic filing, the graph and data table of conducted emission is saved with filename: conducted.pdf.

Judgment: Pass by 13.34 dB

# INTERTEK TESTING SERVICES

Applicant: Sphero HK Limited  
 Model: SP001

Date of Test: April 22, 2017

Worst-Case Operating Mode: PC Charging & Play

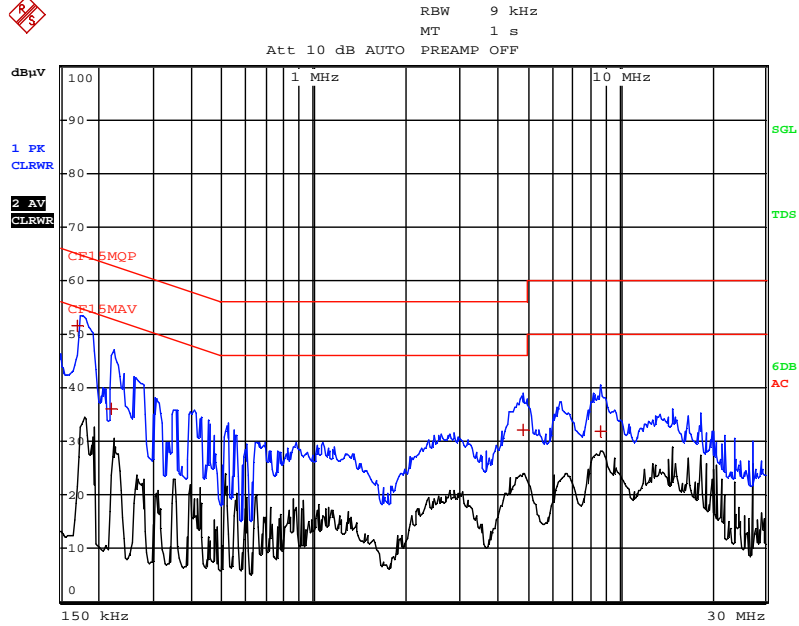

EDIT PEAK LIST (Final Measurement Results)

Trace1: CF15MQP  
 Trace2: CF15MAV  
 Trace3: ---

TRACE	FREQUENCY	LEVEL dB $\mu$ V	DELTA LIMIT dB
1 Quasi Peak	172.5 kHz	51.49 N	-13.34
1 Quasi Peak	222 kHz	36.05 L1	-26.69
1 Quasi Peak	4.839 MHz	32.19 L1	-23.81
1 Quasi Peak	8.682 MHz	31.83 L1	-28.16

Note: Measurement Uncertainty is  $\pm 4.2$ dB at a level of confidence of 95%.

## INTERTEK TESTING SERVICES

Applicant: Sphero HK Limited  
 Model: SP001

Date of Test: April 22, 2017

Worst-Case Operating Mode: Transmitting (Bluetooth 4.0 BLE)

Table 1  
**Radiated Emissions**  
 Pursuant to FCC Part 15 Section 15.249 Requirement

Lowest Channel

Polarization	Frequency (MHz)	Reading (dB $\mu$ V)	Pre-Amp Gain (dB)	Antenna Factor (dB)	Net at 3m - Peak (dB $\mu$ V/m)	Average Factor (dB)	Calculated at 3m (dB $\mu$ V/m)	Average Limit at 3m (dB $\mu$ V/m)	Margin (dB)
H	2402.000	104.1	33	29.4	100.5	52.1	48.4	94.0	-45.6
<b>H</b>	<b>4804.000</b>	<b>40.5</b>	<b>33</b>	<b>34.9</b>	<b>42.4</b>	<b>52.1</b>	<b>-9.7</b>	<b>54.0</b>	<b>-63.7</b>
H	7206.000	39.4	33	37.9	44.3	52.1	-7.8	54.0	-61.8
V	9608.000	39.2	33	40.4	46.6	52.1	-5.5	54.0	-59.5
<b>V</b>	<b>12010.000</b>	<b>42.2</b>	<b>33</b>	<b>40.5</b>	<b>49.7</b>	<b>52.1</b>	<b>-2.4</b>	<b>54.0</b>	<b>-56.4</b>
H	14412.000	44.5	33	40.0	51.5	52.1	-0.6	54.0	-54.6

Polarization	Frequency (MHz)	Reading (dB $\mu$ V)	Pre-Amp Gain (dB)	Antenna Factor (dB)	Net at 3m - Peak (dB $\mu$ V/m)	Peak Limit at 3m (dB $\mu$ V/m)	Margin (dB)
H	2402.000	104.1	33	29.4	100.5	114.0	-13.5
<b>H</b>	<b>4804.000</b>	<b>40.5</b>	<b>33</b>	<b>34.9</b>	<b>42.4</b>	<b>74.0</b>	<b>-31.6</b>
H	7206.000	39.4	33	37.9	44.3	74.0	-29.7
V	9608.000	39.2	33	40.4	46.6	74.0	-27.4
<b>V</b>	<b>12010.000</b>	<b>42.2</b>	<b>33</b>	<b>40.5</b>	<b>49.7</b>	<b>74.0</b>	<b>-24.3</b>
H	14412.000	44.5	33	40.0	51.5	74.0	-22.5

- NOTES:
1. Peak Detector Data unless otherwise stated.
  2. All measurements were made at 3 meters. Harmonic emissions not detected at the 3-meter distances were measured at 0.3-meter and an inverse proportional extrapolation was performed to compare the signal level to the 3-meter limit. No other harmonic emissions than those reported were detected at a test distance of 0.3-meter.
  3. Negative sign in the column shows value below limit.
  4. Horn antenna is used for the emission over 1000MHz.
  5. Emission (the row indicated by **bold italic**) within the restricted band meets the requirement of FCC Part 15 Section 15.205.
  6. Measurement Uncertainty is  $\pm 5.3$ dB at a level of confidence of 95%.

## INTERTEK TESTING SERVICES

Applicant: Sphero HK Limited  
 Model: SP001

Date of Test: April 22, 2017

Worst-Case Operating Mode: Transmitting (Bluetooth 4.0 BLE)

Table 2  
**Radiated Emissions**  
 Pursuant to FCC Part 15 Section 15.249 Requirement

Middle Channel

Polarization	Frequency (MHz)	Reading (dB $\mu$ V)	Pre-Amp Gain (dB)	Antenna Factor (dB)	Net at 3m - Peak (dB $\mu$ V/m)	Average Factor (dB)	Calculated at 3m (dB $\mu$ V/m)	Average Limit at 3m (dB $\mu$ V/m)	Margin (dB)
H	2440.000	104.2	33	29.4	100.6	52.1	48.5	94.0	-45.5
<b>H</b>	<b>4880.000</b>	<b>40.5</b>	<b>33</b>	<b>34.9</b>	<b>42.4</b>	<b>52.1</b>	<b>-9.7</b>	<b>54.0</b>	<b>-63.7</b>
<b>H</b>	<b>7320.000</b>	<b>39.6</b>	<b>33</b>	<b>37.9</b>	<b>44.5</b>	<b>52.1</b>	<b>-7.6</b>	<b>54.0</b>	<b>-61.6</b>
V	9760.000	39.2	33	40.4	46.6	52.1	-5.5	54.0	-59.5
<b>V</b>	<b>12200.000</b>	<b>42.0</b>	<b>33</b>	<b>40.5</b>	<b>49.5</b>	<b>52.1</b>	<b>-2.6</b>	<b>54.0</b>	<b>-56.6</b>
H	14640.000	46.1	33	38.4	51.5	52.1	-0.6	54.0	-54.6

Polarization	Frequency (MHz)	Reading (dB $\mu$ V)	Pre-Amp Gain (dB)	Antenna Factor (dB)	Net at 3m - Peak (dB $\mu$ V/m)	Peak Limit at 3m (dB $\mu$ V/m)	Margin (dB)
H	2440.000	104.2	33	29.4	100.6	114.0	-13.4
<b>H</b>	<b>4880.000</b>	<b>40.5</b>	<b>33</b>	<b>34.9</b>	<b>42.4</b>	<b>74.0</b>	<b>-31.6</b>
<b>H</b>	<b>7320.000</b>	<b>39.6</b>	<b>33</b>	<b>37.9</b>	<b>44.5</b>	<b>74.0</b>	<b>-29.5</b>
V	9760.000	39.2	33	40.4	46.6	74.0	-27.4
<b>V</b>	<b>12200.000</b>	<b>42.0</b>	<b>33</b>	<b>40.5</b>	<b>49.5</b>	<b>74.0</b>	<b>-24.5</b>
H	14640.000	46.1	33	38.4	51.5	74.0	-22.5

- NOTES: 1. Peak Detector Data unless otherwise stated.
2. All measurements were made at 3 meters. Harmonic emissions not detected at the 3-meter distances were measured at 0.3-meter and an inverse proportional extrapolation was performed to compare the signal level to the 3-meter limit. No other harmonic emissions than those reported were detected at a test distance of 0.3-meter.
3. Negative sign in the column shows value below limit.
4. Horn antenna is used for the emission over 1000MHz.
5. Emission (the row indicated by **bold italic**) within the restricted band meets the requirement of FCC Part 15 Section 15.205.
6. Measurement Uncertainty is  $\pm 5.3$ dB at a level of confidence of 95%.

## INTERTEK TESTING SERVICES

Applicant: Sphero HK Limited  
 Model: SP001

Date of Test: April 22, 2017

Worst-Case Operating Mode: Transmitting (Bluetooth 4.0 BLE)

Table 3  
**Radiated Emissions**  
 Pursuant to FCC Part 15 Section 15.249 Requirement

Highest Channel

Polarization	Frequency (MHz)	Reading (dB $\mu$ V)	Pre-Amp Gain (dB)	Antenna Factor (dB)	Net at 3m - Peak (dB $\mu$ V/m)	Average Factor (dB)	Calculated at 3m (dB $\mu$ V/m)	Average Limit at 3m (dB $\mu$ V/m)	Margin (dB)
H	2480.000	103.9	33	29.4	100.3	52.1	48.2	94.0	-45.8
<b>H</b>	<b>4960.000</b>	<b>40.3</b>	<b>33</b>	<b>34.9</b>	<b>42.2</b>	<b>52.1</b>	<b>-9.9</b>	<b>54.0</b>	<b>-63.9</b>
<b>H</b>	<b>7440.000</b>	<b>39.4</b>	<b>33</b>	<b>37.9</b>	<b>44.3</b>	<b>52.1</b>	<b>-7.8</b>	<b>54.0</b>	<b>-61.8</b>
V	9920.000	39.0	33	40.4	46.4	52.1	-5.7	54.0	-59.7
<b>V</b>	<b>12400.000</b>	<b>42.0</b>	<b>33</b>	<b>40.5</b>	<b>49.5</b>	<b>52.1</b>	<b>-2.6</b>	<b>54.0</b>	<b>-56.6</b>
H	14880.000	46.3	33	38.4	51.7	52.1	-0.4	54.0	-54.4

Polarization	Frequency (MHz)	Reading (dB $\mu$ V)	Pre-Amp Gain (dB)	Antenna Factor (dB)	Net at 3m - Peak (dB $\mu$ V/m)	Peak Limit at 3m (dB $\mu$ V/m)	Margin (dB)
H	2480.000	103.9	33	29.4	100.3	114.0	-13.7
<b>H</b>	<b>4960.000</b>	<b>40.3</b>	<b>33</b>	<b>34.9</b>	<b>42.2</b>	<b>74.0</b>	<b>-31.8</b>
<b>H</b>	<b>7440.000</b>	<b>39.4</b>	<b>33</b>	<b>37.9</b>	<b>44.3</b>	<b>74.0</b>	<b>-29.7</b>
V	9920.000	39.0	33	40.4	46.4	74.0	-27.6
<b>V</b>	<b>12400.000</b>	<b>42.0</b>	<b>33</b>	<b>40.5</b>	<b>49.5</b>	<b>74.0</b>	<b>-24.5</b>
H	14880.000	46.3	33	38.4	51.7	74.0	-22.3

- NOTES: 1. Peak Detector Data unless otherwise stated.
2. All measurements were made at 3 meters. Harmonic emissions not detected at the 3-meter distances were measured at 0.3-meter and an inverse proportional extrapolation was performed to compare the signal level to the 3-meter limit. No other harmonic emissions than those reported were detected at a test distance of 0.3-meter.
3. Negative sign in the column shows value below limit.
4. Horn antenna is used for the emission over 1000MHz.
5. Emission (the row indicated by **bold italic**) within the restricted band meets the requirement of FCC Part 15 Section 15.205.
6. Measurement Uncertainty is  $\pm 5.3$ dB at a level of confidence of 95%.

## INTERTEK TESTING SERVICES

Applicant: Sphero HK Limited  
Model: SP001

Date of Test: April 22, 2017

Worst-Case Operating Mode: PC charging & Play

Table 4  
**Radiated Emissions**  
Pursuant to FCC Part 15 Section 15.209 Requirement

Polarization	Frequency (MHz)	Reading (dB $\mu$ V)	Pre-amp (dB)	Antenna Factor (dB)	Net at 3m (dB $\mu$ V/m)	Limit at 3m (dB $\mu$ V/m)	Margin (dB)
H	58.615	34.2	16	11.0	29.2	40.0	-10.8
H	107.843	37.3	16	14.0	35.3	43.5	-8.2
<b>H</b>	<b>131.001</b>	<b>44.4</b>	<b>16</b>	<b>14.0</b>	<b>42.4</b>	<b>43.5</b>	<b>-1.1</b>
H	198.538	41.1	16	16.0	41.1	43.5	-2.4
H	201.569	42.5	16	16.0	42.5	43.5	-1.0
H	207.874	39.5	16	17.0	40.5	43.5	-3.0
<b>V</b>	<b>258.314</b>	<b>25.2</b>	<b>16</b>	<b>21.0</b>	<b>30.2</b>	<b>46.0</b>	<b>-15.8</b>
H	603.634	17.5	16	29.0	30.5	46.0	-15.5

NOTES: 1. Peak Detector Data unless otherwise stated.

- All measurements were made at 3 meters. Harmonic emissions not detected at the 3-meter distances were measured at 0.3-meter and an inverse proportional extrapolation was performed to compare the signal level to the 3-meter limit. No other harmonic emissions than those reported were detected at a test distance of 0.3-meter.
- Negative sign in the column shows value below limit.
- Horn antenna is used for the emission over 1000MHz.
- Emission (the row indicated by **bold italic**) within the restricted band meets the requirement of FCC Part 15 Section 15.205.
- Measurement Uncertainty is  $\pm 5.3$ dB at a level of confidence of 95%.

## INTERTEK TESTING SERVICES

---

### 4.0 **Equipment Photographs**

For electronic filing, the photographs are saved with filename: external photos.pdf and internal photos.pdf.

### 5.0 **Product Labelling**

For electronics filing, the FCC ID label artwork and the label location are saved with filename: label.pdf.

### 6.0 **Technical Specifications**

For electronic filing, the block diagram and schematic of the tested EUT are saved with filename: block.pdf and circuit.pdf respectively.

### 7.0 **Instruction Manual**

For electronic filing, a preliminary copy of the Instruction Manual is saved with filename: manual.pdf.

This manual will be provided to the end-user with each unit sold/leased in the United States.

## INTERTEK TESTING SERVICES

---

### 8.0 **Miscellaneous Information**

The miscellaneous information includes details of the test procedure and measured bandwidth / calculation of factor such as pulse desensitization and averaging factor (calculation and timing diagram).

### 8.1 Radiated Emission on the Bandedge

From the following plots, they show that the fundamental emissions are confined in the specified band (2400MHz to 2483.5MHz). In case of the fundamental emissions are within two standard bandwidths from the bandedge, the delta measurement technique is used for determining bandedge compliance. Standard bandwidth is the bandwidth specified by ANSI C63.10 (2013) for frequency being measured.

Emissions radiated outside of the specified frequency bands, except harmonics, are attenuated by 50dB below the level of the fundamental or to the general radiated emissions limits in Section 15.209, whichever is the lesser attenuation, which meet the requirement of part 15.249(d).



# INTERTEK TESTING SERVICES

## Peak Measurement (Bluetooth 4.0 BLE)

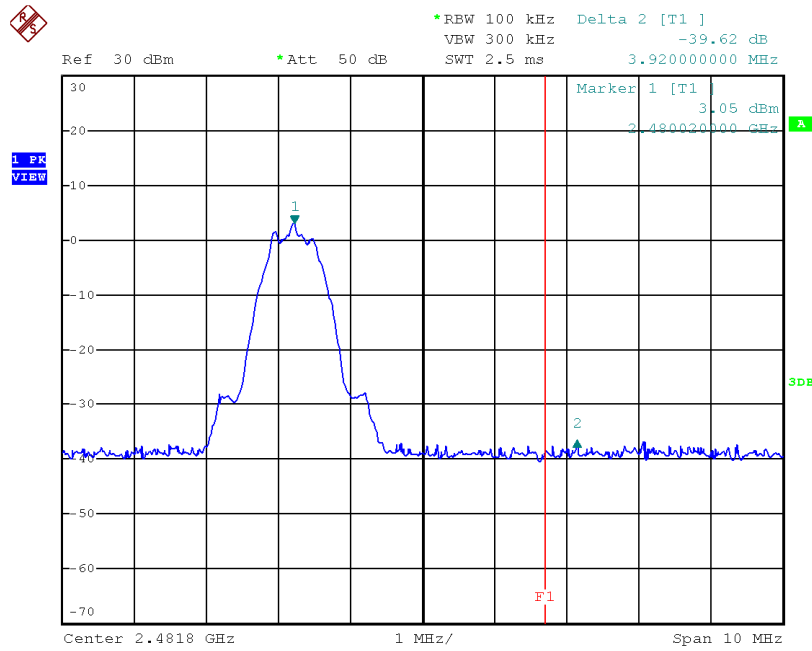
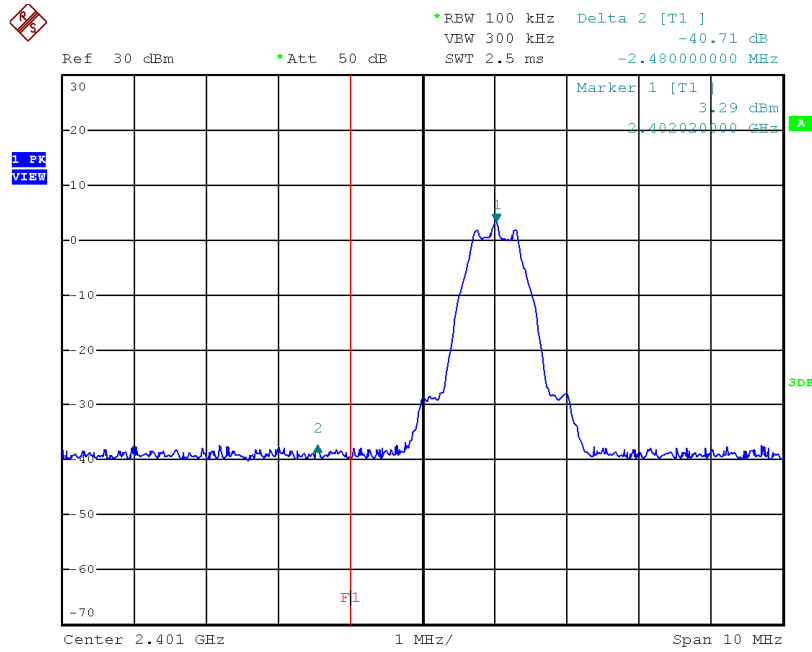

## INTERTEK TESTING SERVICES

---

### Peak Measurement (Bluetooth 4.0 BLE)

Bandedge compliance is determined by applying marker-delta method, i.e. (Bandedge Plot).

Lower bandedge

Peak Resultant field strength = Fundamental emissions (peak value) – delta from the plot

$$=100.5 \text{ dB}\mu\text{V/m} - 40.7 \text{ dB}$$

$$=59.8 \text{ dB}\mu\text{V/m}$$

Average Resultant field strength = Fundamental emissions (average value) – delta from the plot

$$=48.4 \text{ dB}\mu\text{V/m} - 40.7 \text{ dB}$$

$$=7.7 \text{ dB}\mu\text{V/m}$$

Upper bandedge

Peak Resultant field strength = Fundamental emissions (peak value) – delta from the plot

$$=100.3 \text{ dB}\mu\text{V/m} - 39.6 \text{ dB}$$

$$=60.7 \text{ dB}\mu\text{V/m}$$

Average Resultant field strength = Fundamental emissions (average value) – delta from the plot

$$=48.2 \text{ dB}\mu\text{V/m} - 39.6 \text{ dB}$$

$$=8.6 \text{ dB}\mu\text{V/m}$$

The resultant field strength meets the general radiated emission limit in Section 15.209, which does not exceed 74 dB $\mu$ V/m (Peak Limit) and 54 dB $\mu$ V/m (Average Limit).

## INTERTEK TESTING SERVICES

---

### 8.2 Discussion of Pulse Desensitization

Pulse desensitivity is not applicable for this device. The effective period (Teff) is approximately 0.248ms for a digital "1" bit which illustrated on technical specification, with a resolution bandwidth (3dB) of 1MHz, so the pulse desensitivity factor is 0dB.

### 8.3 Calculation of Average Factor

(Bluetooth 4.0 BLE)

The duty cycle is simply the on-time divided by the period:

The duration of one cycle = 100ms

Effective period of the cycle = 0.248ms

DC =  $0.248/100 = 0.00248$

Therefore, the averaging factor is found by  $20\log 0.00248 = 52.1\text{dB}$ .

# INTERTEK TESTING SERVICES

## Average Factor (Bluetooth 4.0 BLE)

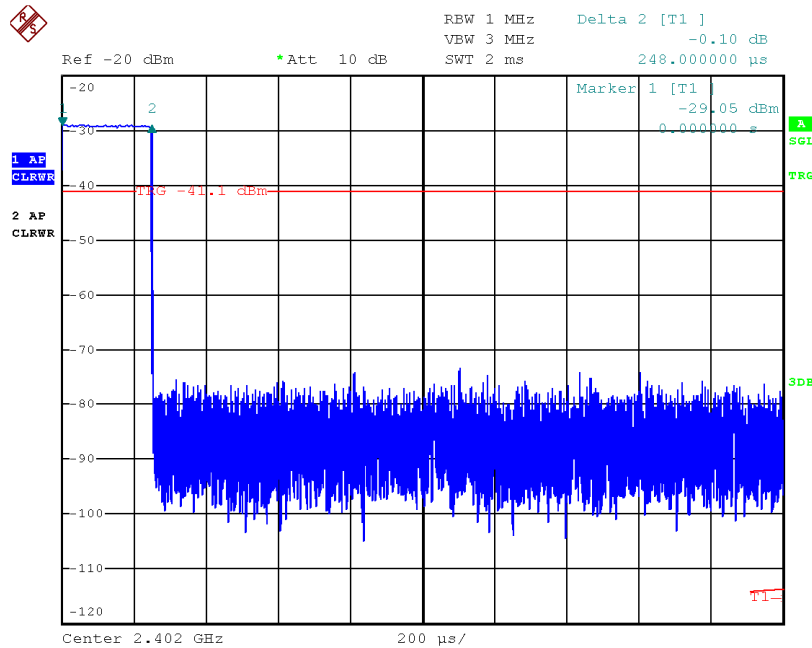
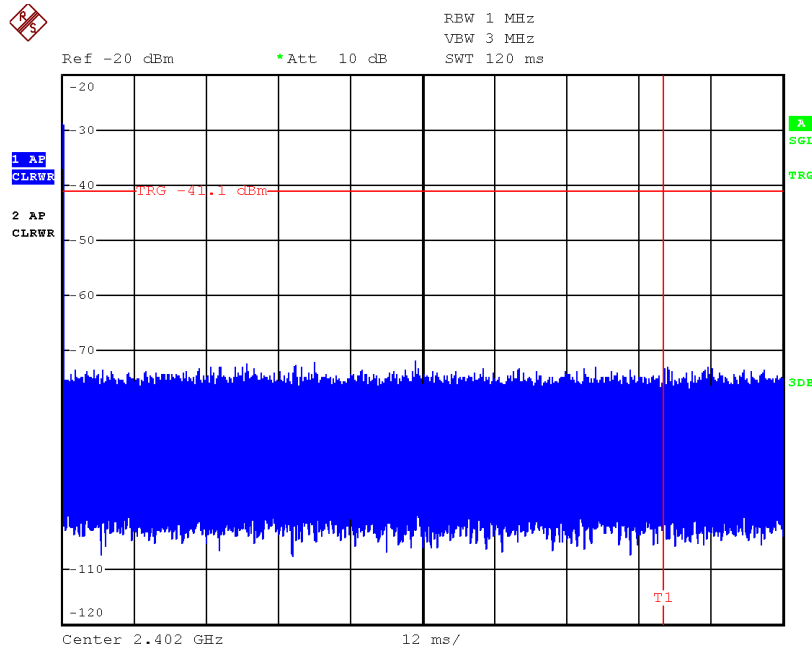

## INTERTEK TESTING SERVICES

---

### 8.4 Emissions Test Procedures

The following is a description of the test procedure used by Intertek Testing Services Hong Kong Ltd. in the measurements of transmitter operating under the Part 15, Subpart C rules.

The transmitting equipment under test (EUT) is placed on a wooden turntable which is four feet in diameter and approximately 0.8m in height above the ground plane for emission measurement at or below 1GHz and 1.5m in height above the ground plane for emission measurement above 1GHz. During the radiated emissions test, the turntable is rotated and any cables leaving the EUT are manipulated to find the configuration resulting in maximum emissions. The EUT is adjusted through all three orthogonal axis to obtain maximum emission levels. The antenna height and polarization are also varied during the testing to search for maximum signal levels. The height of the antenna is varied from one to four meters.

Detector function for radiated emissions is in peak mode. Average readings, when required, are taken by measuring the duty cycle of the equipment under test and subtracting the corresponding amount in dB from the measured peak readings. A detailed description for the calculation of the average factor can be found in Exhibit 8.3.

The frequency range scanned is from the lowest radio frequency signal generated in the device which is greater than 9 kHz to the tenth harmonic of the highest fundamental frequency or 40 GHz, whichever is lower. For line conducted emissions, the range scanned is 150 kHz to 30 MHz.

## INTERTEK TESTING SERVICES

---

### 8.4 Emissions Test Procedures (cont'd)

The EUT is warmed up for 15 minutes prior to the test.

AC power to the unit is varied from 85% to 115% nominal and variation in the fundamental emission field strength is recorded. If battery powered, a new, fully charged battery is used.

Conducted measurements were made as described in ANSI C63.10 (2013).

The IF bandwidth used for measurement of radiated signal strength was 100 kHz or greater when frequency is below 1000 MHz. Where pulsed transmissions of short enough pulse duration warrant, a greater bandwidth is selected according to the recommendations of Hewlett Packard Application Note 150-2. A discussion of whether pulse desensitivity is applicable to this unit is included in this report (See Exhibit 8.1). Above 1000 MHz, a resolution bandwidth of 1 MHz is used.

Transmitter measurements are normally conducted at a measurement distance of three meters. However, to assure low enough noise floor in the forbidden bands and above 1 GHz, signals are acquired at a distance of one meter or less. All measurements are extrapolated to three meters using inverse scaling, unless otherwise reported. Measurements taken at a closer distance are so marked.

# INTERTEK TESTING SERVICES

## 8.4.1 Radiated Emission Test Setup

The figure below shows the test setup, which is utilized to make these measurements.

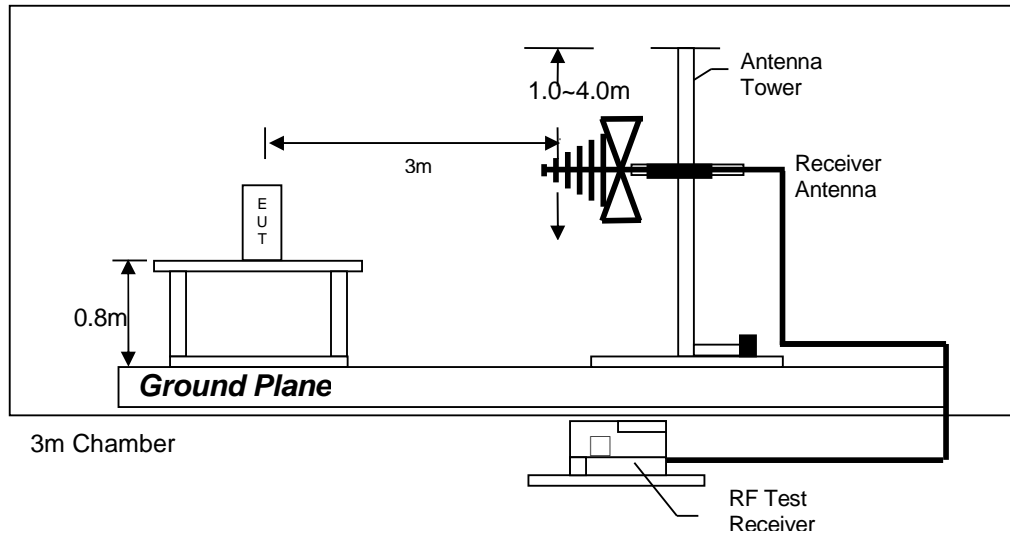

Test setup of radiated emissions up to 1GHz

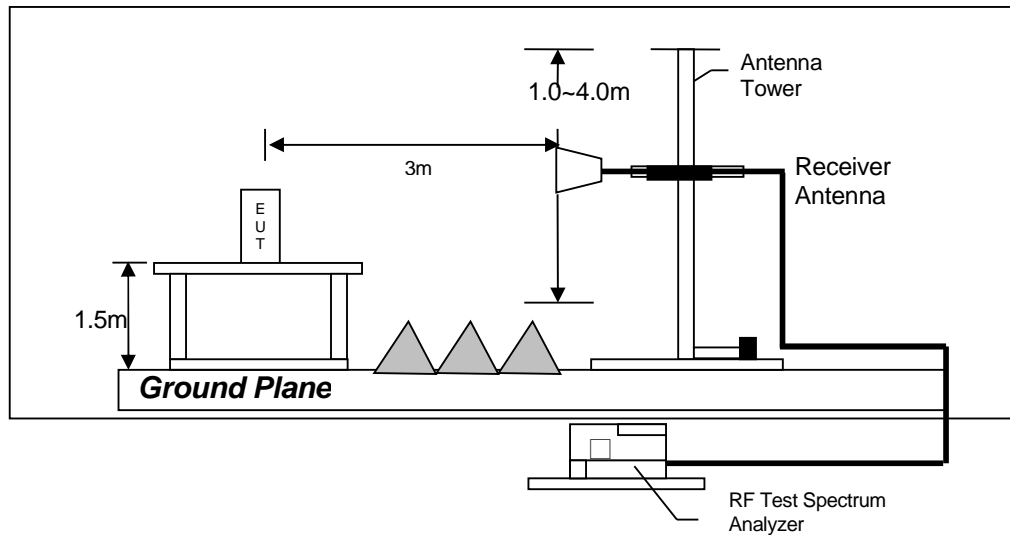

Test setup of radiated emissions above 1GHz

## INTERTEK TESTING SERVICES

---

### 8.4.2 Conducted Emission Test Procedures

For tabletop equipment, the EUT along with its peripherals were placed on a 1.0m(W)×1.5m(L) and 0.8m in height wooden table. For floor-standing equipment, the EUT and all cables were insulated, if required, from the ground plane by up to 12 mm of insulating material. The EUT was adjusted to maintain a 0.4 meter space from a vertical reference plane. The EUT was connected to power mains through a line impedance stabilization network (LISN), which provided 50 ohm coupling impedance for measuring instrument and the chassis ground was bounded to the horizontal ground plane of shielded room. The excess power cable between the EUT and the LISN was bundled.

All connecting cables of EUT and peripherals were moved to find the maximum emission.

### 8.4.3 Conducted Emission Test Setup

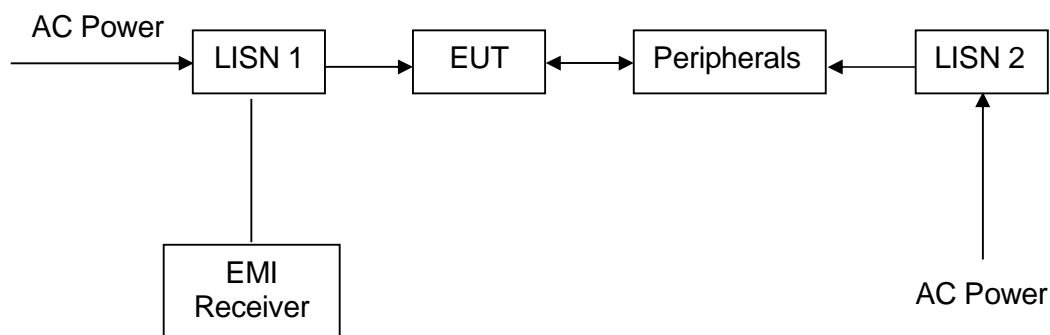

## 9.0 Confidentiality Request

For electronic filing, a preliminary copy of the confidentiality request is saved with filename: request.pdf.



## INTERTEK TESTING SERVICES

---

### 10.0 Equipment List

#### 1) Radiated Emissions Test

Equipment	Spectrum Analyzer	EMI Test Receiver (9kHz to 26.5GHz)	BiConiLog Antenna
Registration No.	EW-2253	EW-3156	EW-3061
Manufacturer	R&S	R&S	EMCO
Model No.	FSP40	ESR26	3142E
Calibration Date	Jun. 15, 2016	Dec. 06, 2016	Sep. 23, 2016
Calibration Due Date	Jun. 15, 2017	Dec. 06, 2017	Sep. 23, 2017

Equipment	Double Ridged Guide Antenna	Broad-Band Horn Antenna
Registration No.	EW-1133	EW-1679
Manufacturer	EMCO	SCHWARZBECK
Model No.	3115	BBHA9170
Calibration Date	Nov. 05, 2015	Jun. 28, 2016
Calibration Due Date	Nov. 05, 2017	Jun. 28, 2017

#### 2) Conducted Emissions Test

Equipment	EMI Test Receiver (9kHz to 26.5GHz)	Artificial Mains	Pulse Limiter
Registration No.	EW-3156	EW-0192	EW-3248
Manufacturer	R&S	R&S	R&S
Model No.	ESR26	ESH3-Z5	E3H3-Z2
Calibration Date	Dec. 06, 2016	Aug. 26, 2016	Oct. 12, 2016
Calibration Due Date	Dec. 06, 2017	Aug. 26, 2017	Oct. 12, 2017

#### 3) Bandedge & Average factor Measurement Test

Equipment	Spectrum Analyzer
Registration No.	EW-2466
Manufacturer	R&S
Model No.	FSP30
Calibration Date	Oct. 03, 2016
Calibration Due Date	Aug. 20, 2017

END OF TEST REPORT