

VIDEO NODE INSTALLATION / REFERENCE GUIDE

SAFETY PRECAUTIONS / INSTALLATION CONSIDERATIONS

- Installation and service should be performed by a qualified licensed electrician.
- All electrical work should be completed by a licensed electrical contractor.
- Installation should conform to all national and/ or local municipal laws and codes.
- Disconnect or safe-off all power before installation.
- **DO NOT INSTALL DAMAGED PRODUCT!** This Video Node has been properly packed so that no parts should have been damaged. Inspect to confirm. Any part damaged or broken during or after assembly should be replaced.
- These instructions do not purport to cover all details or variations in equipment nor to provide every possible contingency to meet in connection with installation, operation, or maintenance. Should further information be desired or should particular problems arise which are not covered sufficiently for the purchaser's or owner's purposes, please contact Sensity Systems directly.
- Installation is intended for outdoor luminaires. Product should not be installed ≤ 20 ft from ground level and must be considered out of reach from normal access.
- Product must be grounded per supplied ground provision per national and/ or local municipal laws and codes. Unit must not be under normal operation if left ungrounded.



WARNING it.

Environmental Considerations

- Operational Temperature: -30°C - $+55^{\circ}\text{C}$ (-22°F - 131°F)
- Storage Temperature: -50°C - $+65^{\circ}\text{C}$ (-58°F - 149°F)
- Ingress Protection Rating: IP65 Compliant

Required Tool List

- Flat Head Screwdriver
- T20 Torx Driver
- Cable De-Latching Tool
- UV resistant outdoor cable ties

Power, Current and Weight Requirements

Voltage Configuration	Power (Watts)	Current (A)	Maximum Weight (lbs.)
100-277V	18W	0.06 – 0.15	9.0
480V	20W	0.05	10.5

Pole Mounting Requirements

Mounting Type	Horizontal Pole Mount	Vertical Pole Mount
Round Pole Diameter	1 5/8" – 2 3/8"	Minimum 3"
Square Pole Dimension	Minimum 4" height	Minimum 3" width

Assembly and Mounting Instructions

Pole Mounting illustration is shown. Box arm mounting instructions are same, substituting pole for box arm following mounting requirement size above.

1. Install the Video Node Bracket onto the pole with the correct orientation according to illustration below. The power connector for the Video Node should point towards the luminaire. Install the bracket using supplied stainless steel bands. Tighten bands until secure and bracket will not move. Do not over-tighten.

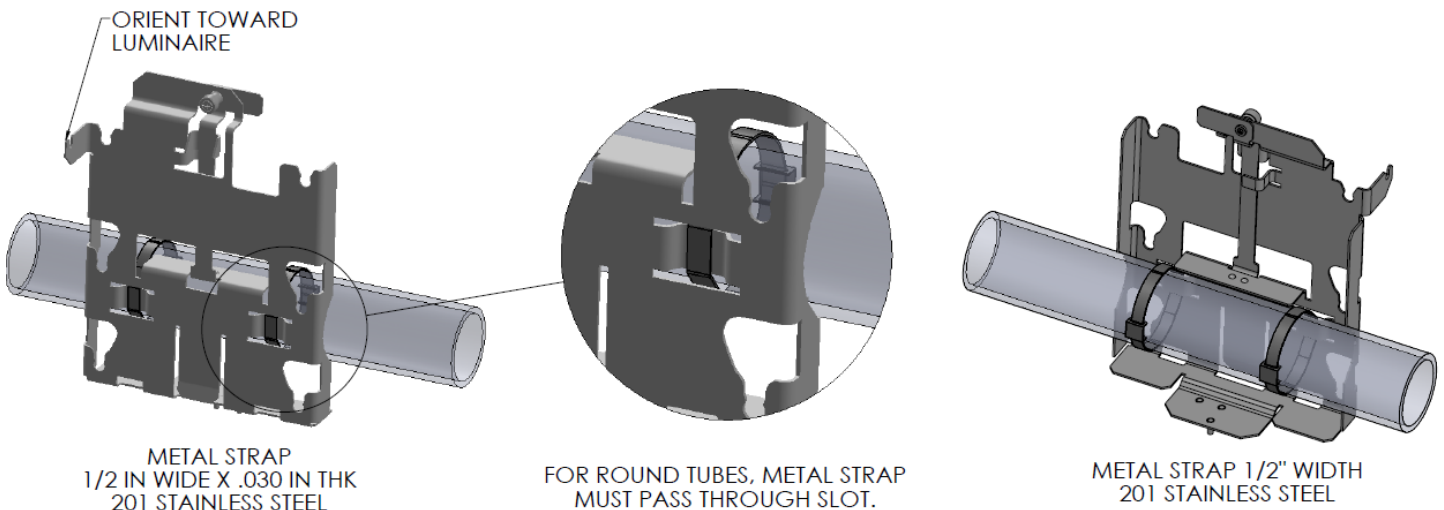

VIDEO NODE INSTALLATION / REFERENCE GUIDE

- Align the Video Node against the tabs on the Video Node Bracket. Do not adjust the tabs. Press the Video Node firmly against the node bracket and slide it downwards to lock the video node in place. Ensure the latch is engaged. Install the antennas onto the Video Node.
- Tighten the thumb screw on the latch.

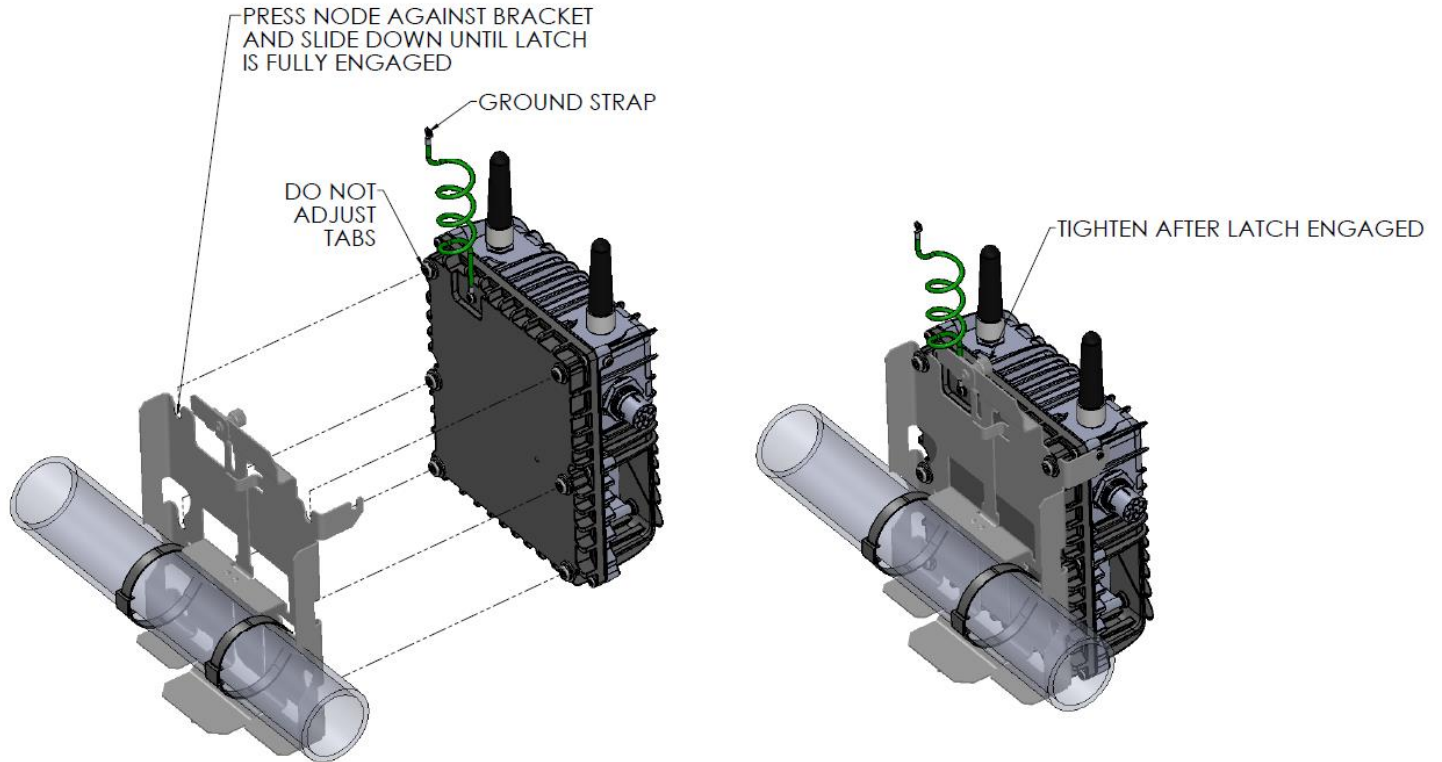

- Identify orientation for the camera kit (align with the viewing direction). Attach the camera kit to the bottom of the Video Node Bracket via wingnuts that are provided on the bracket and tighten. Cameras should not have any movement once secured. No not over-tighten.

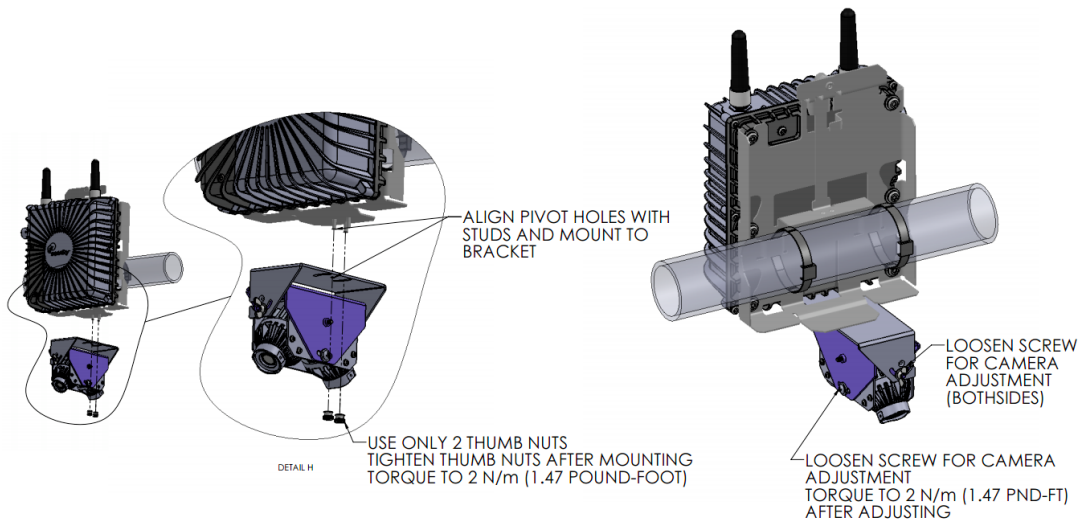

VIDEO NODE INSTALLATION / REFERENCE GUIDE

- Connect the camera cables to the QMA ports on the Video Node (the connector door does not need to be removed for camera cable installation) the video sensors can be installed in either QMA port.
- Provide grounding to the ground strap per local codes.

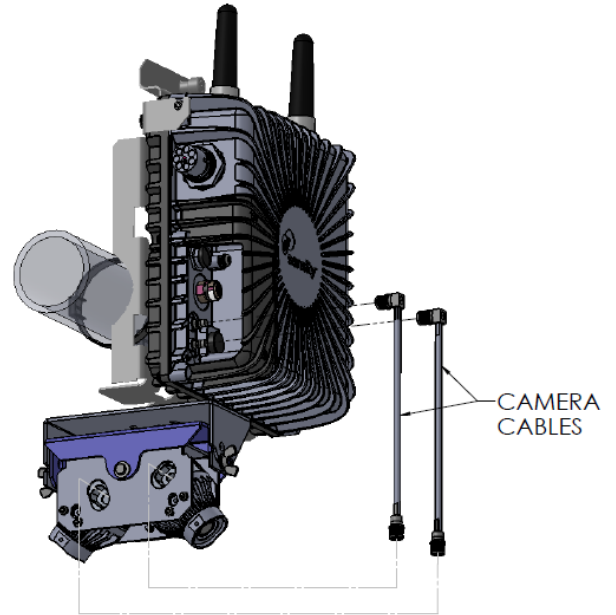
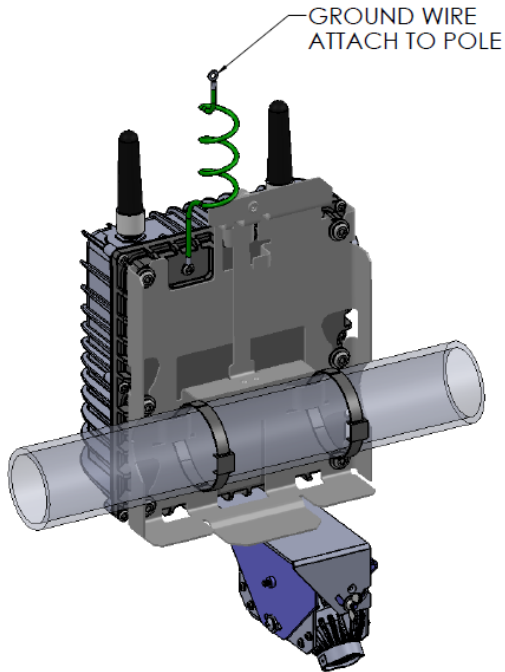

- Connect the Video Node to the power source either onto an External Core Node or the luminaire. A T-splitter may need to be deployed). Use the de-latching tool to remove the cap on the connector of the power source (External Core Node or luminaire). Connect the Video Node and the mating connector using the power cable. Press the cable firmly into the connector to ensure the connector tabs are fully latched.

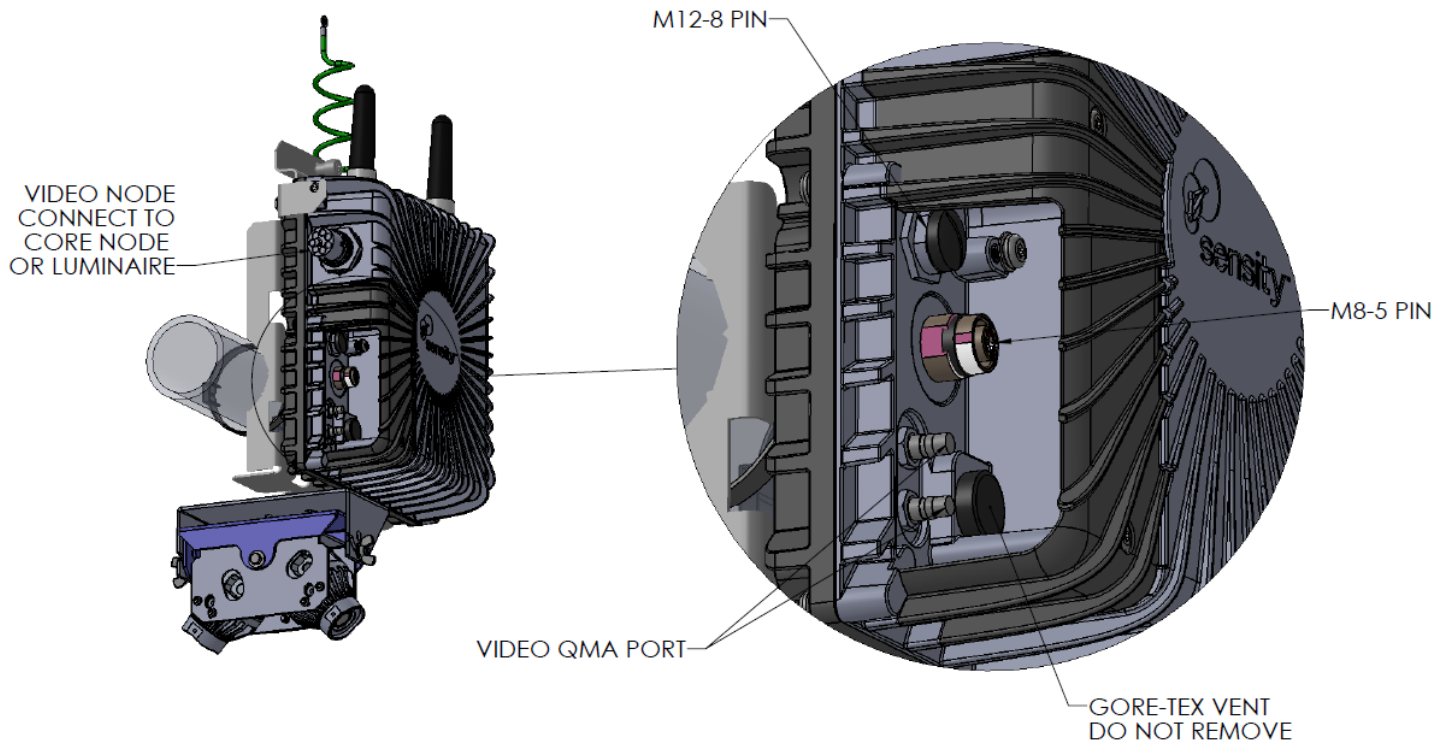

- Secure all power cables to pole using UV rated cable ties. Refer to local and national codes for additional clarification and laws.
- Commission the Video Node by following: 'Video Node Commissioning Procedure'. Contact Sensity Systems for additional guidance to commissioning process.



VIDEO NODE INSTALLATION / REFERENCE GUIDE

REGULATORY COMPLIANCE STATEMENTS

The Sensity Video Node contains an IEEE 802.11 a/b/g/n radio which acts as a Client, and not as an Access Point.

USA

The Video Node contains a radio transmitter with the FCC ID# SXNWPEA-252NI

This equipment has been tested and found to comply with the limits for a Class A digital device, pursuant to part 15 of the FCC Rules. These limits are designed to provide reasonable protection against harmful interference when the equipment is operated in a commercial environment. This equipment generates, uses, and can radiate radio frequency energy and, if not installed and used in accordance with the instruction manual, may cause harmful interference to radio communications. Operation of this equipment in a residential area is likely to cause harmful interference in which case the user will be required to correct the interference at his own expense.

Modifications or changes not expressly approved by Sensity Systems may result in the equipment no longer complying with FCC requirements for Class A digital devices. In that event, your right to use the equipment may be limited by FCC regulations, and you may be required to correct any interference to radio or television communications at your own expense.

There are no serviceable items within this unit and cannot be serviced by any end user; regardless if in-warranty or out of warranty.

If the unit is malfunctioning or causing interference with existing radio devices:

- Determine cause of interference and remove suspect device from service
- Contact Sensity Systems Customer Service at 1-855-500-SENS (7367)

The combination of the Video Node's radio and antennas (noted below) have been found to be compliant to the FCC requirements set forth in addressing RF Exposure from radio frequency devices. This Video Node should be installed more than 20 cm (7.9 in.) from your body or nearby persons. The video node must be installed to maintain a minimum 20 cm (7.9 in.) co-located separation distance from other FCC approved indoor/outdoor antennas used on other radio devices.

Canada

The Video Node contains a radio transmitter with the Industry Canada ID# 20569-WPEA252NI

This Class A digital apparatus complies with Canadian ICES-003.

Cet appareil numérique de la classe A est conforme à la norme NMB-003 du Canada.

This device complies with Industry Canada's licence-exempt RSSs. Operation is subject to the following two conditions:

- (1) This device may not cause interference; and
- (2) This device must accept any interference, including interference that may cause undesired operation of the device.

Le présent appareil est conforme aux CNR d'Industrie Canada applicables aux appareils radio exempts de licence. L'exploitation est autorisée aux deux conditions suivantes:

- (1) l'appareil ne doit pas produire de brouillage;
- (2) l'utilisateur de l'appareil doit accepter tout brouillage radioélectrique subi, même si le brouillage est susceptible d'en compromettre le fonctionnement.

The user manual for local area network devices shall contain instructions related to the restrictions mentioned in the above sections, namely that:

- the device for operation in the band 5150-5250 MHz is only for indoor use to reduce the potential for harmful interference to co-channel mobile satellite systems;
- the maximum antenna gain permitted for devices in the bands 5250-5350 MHz and 5470-5725 MHz shall comply with the e.i.r.p. limit; and
- the maximum antenna gain permitted for devices in the band 5725-5825 MHz shall comply with the e.i.r.p. limits specified for point-to-point and non point-to-point operation as appropriate.

Users should also be advised that high-power radars are allocated as primary users (i.e. priority users) of the bands 5250-5350 MHz and 5650-5850 MHz and that these radars could cause interference and/or damage to LE-LAN devices



VIDEO NODE INSTALLATION / REFERENCE GUIDE

The combination of the Video Node's radio and antennas (noted below) have been found to be compliant to Industry Canada RSS-102 clause 2.6 requirements set forth in addressing RF Exposure from radio frequency devices.

This Video Node should be installed more than 20 cm (7.9 in.) from your body or nearby persons. The Video Node must be installed to maintain a minimum 20 cm (7.9 in.) co-located separation distance from other IC approved indoor/outdoor antennas used on other radio devices.

Antenna

The following antennas are approved for use with the Sensity Video Nodes:

Sensity Part Number	Frequency Band	Description	Typical Gain (dBi)
600-0002-00	5 GHz	Dipole with N-type connector (male) - Ships with product	2.4
600-0110-00	2.4 / 5 GHz	Dipole with N-type connector (male) - Optional	2.0 @ 2.4 GHz
			4.0 @ 5 GHz

Safety

Connecting the supplemental ground to the unit in accordance with the NESC is essential before connecting input supply cable.

WARNING: This equipment must be grounded. You must ground this equipment by connecting a customer-supplied ground wire to the grounding lug on the chassis, and then connecting the other end to a reliable earth ground. If you are uncertain that suitable grounding is available, contact the appropriate electrical inspection authority or an electrician. The ground bonding conductor used must be #12 AWG, 1 mm² or equivalent.

The equipment is suitable for installation outdoors.

The equipment is intended for professional installation and service by trained personnel only (no operator access).

Equipment is intended for installation in Restricted Access Locations.

This product was evaluated for mounting with a specific mounting bracket, which is suitable for pole mounting.

This product requires a surge protector device (SPD) or surge arrester as part of the installation to address transient overvoltages exceeding Overvoltage Category II, 2500 V_{peak}.