

**In order to comply with FCC contention based protocol requirements for the 3.65-3.70GHz band, the XtremeRange3 is designed around the AR5414 802.11 MAC/BB chip from Atheros Communications. The silicon has been wifi certified and implements the Distribution Coordination Function (DCF) as described in the official IEEE 802.11 standards document. The excerpt below shows outlines the contention protocol and the algorithms the DCF follows to initiate and service contention periods between Access Points and Stations.**

### 9.2 DCF

The basic medium access protocol is a DCF that allows for automatic medium sharing between compatible PHYs through the use of CSMA/CA and a random backoff time following a busy medium condition. In addition, all directed traffic uses immediate positive acknowledgment (ACK frame) where retransmission is scheduled by the sender if no ACK is received.

The CSMA/CA protocol is designed to reduce the collision probability between multiple STAs accessing a medium, at the point where collisions would most likely occur. Just after the medium becomes idle following a busy medium (as indicated by the CS function) is when the highest probability of a collision exists. This is because multiple STAs could have been waiting for the medium to become available again. This is the situation that necessitates a random backoff procedure to resolve medium contention conflicts.

Carrier sense shall be performed both through physical and virtual mechanisms.

The virtual carrier-sense mechanism is achieved by distributing reservation information announcing the impending use of the medium. The exchange of RTS and CTS frames prior to the actual data frame is one means of distribution of this medium reservation information. The RTS and CTS frames contain a Duration/ID field that defines the period of time that the medium is to be reserved to transmit the actual data frame and the returning ACK frame. All STAs within the reception range of either the originating STA (which transmits the RTS) or the destination STA (which transmits the CTS) shall learn of the medium reservation. Thus a STA can be unable to receive from the originating STA, yet still know about the impending use of the medium to transmit a data frame.

Another means of distributing the medium reservation information is the Duration/ID field in directed frames. This field gives the time that the medium is reserved, either to the end of the immediately following ACK, or in the case of a fragment sequence, to the end of the ACK following the next fragment.

The RTS/CTS exchange also performs both a type of fast collision inference and a transmission path check. If the return CTS is not detected by the STA originating the RTS, the originating STA may repeat the process (after observing the other medium-use rules) more quickly than if the long data frame had been transmitted and a return ACK frame had not been detected.

Another advantage of the RTS/CTS mechanism occurs where multiple BSSs utilizing the same channel overlap. The medium reservation mechanism works across the BSA boundaries. The RTS/CTS mechanism may also improve operation in a typical situation where all STAs can receive from the AP, but cannot receive from all other STAs in the BSA.

The RTS/CTS mechanism cannot be used for MPDUs with broadcast and multicast immediate address because there are multiple destinations for the RTS, and thus potentially multiple concurrent senders of the CTS in response. The RTS/CTS mechanism need not be used for every data frame transmission. Because the

additional RTS and CTS frames add overhead inefficiency, the mechanism is not always justified, especially for short data frames.

The use of the RTS/CTS mechanism is under control of the `dot11RTSThreshold` attribute. This attribute may be set on a per-STA basis. This mechanism allows STAs to be configured to use RTS/CTS either always, never, or only on frames longer than a specified length.

A STA configured not to initiate the RTS/CTS mechanism shall still update its virtual carrier-sense mechanism with the duration information contained in a received RTS or CTS frame, and shall always respond to an RTS addressed to it with a CTS.

The medium access protocol allows for STAs to support different sets of data rates. All STAs shall receive all the data rates in `aBasicRateSet` and transmit at one or more of the `aBasicRateSet` data rates. To support the proper operation of the RTS/CTS and the virtual carrier-sense mechanism, all STAs shall be able to detect the RTS and CTS frames. For this reason the RTS and CTS frames shall be transmitted at one of the `aBasicRateSet` rates. (See 9.6 for a description of multirate operation.)

Data frames sent under the DCF shall use the frame type Data and subtype Data or Null Function. STAs receiving Data type frames shall only consider the frame body as the basis of a possible indication to LLC.

### 9.2.1 Carrier-sense mechanism

Physical and virtual carrier-sense functions are used to determine the state of the medium. When either function indicates a busy medium, the medium shall be considered busy; otherwise, it shall be considered idle.

A physical carrier-sense mechanism shall be provided by the PHY. See Clause 12 for how this information is conveyed to the MAC. The details of physical carrier sense are provided in the individual PHY specifications.

A virtual carrier-sense mechanism shall be provided by the MAC. This mechanism is referred to as the network allocation vector (NAV). The NAV maintains a prediction of future traffic on the medium based on duration information that is announced in RTS/CTS frames prior to the actual exchange of data. The duration information is also available in the MAC headers of all frames sent during the CP other than PS-Poll Control frames. The mechanism for setting the NAV using RTS/CTS in the DCF is described in 9.2.5.4, and use of the NAV in PCF is described in 9.3.2.2.

The carrier-sense mechanism combines the NAV state and the STA's transmitter status with physical carrier sense to determine the busy/idle state of the medium. The NAV may be thought of as a counter, which counts down to zero at a uniform rate. When the counter is zero, the virtual carrier-sense indication is that the medium is idle; when nonzero, the indication is busy. The medium shall be determined to be busy whenever the STA is transmitting.

### 9.2.2 MAC-Level acknowledgments

The reception of some frames, as described in 9.7, 9.2.8, and 9.3.3.4, requires the receiving STA to respond with an acknowledgment, generally an ACK frame, if the FCS of the received frame is correct. This technique is known as positive acknowledgment.

Lack of reception of an expected ACK frame indicates to the source STA that an error has occurred. Note, however, that the destination STA may have received the frame correctly, and that the error may have occurred in the reception of the ACK frame. To the initiator of the frame exchange, this condition is indistinguishable from an error occurring in the initial frame.

### 9.2.3 Interframe space (IFS)

The time interval between frames is called the IFS. A STA shall determine that the medium is idle through the use of the carrier-sense function for the interval specified. Four different IFSs are defined to provide priority levels for access to the wireless media; they are listed in order, from the shortest to the longest. Figure 49 shows some of these relationships.

- a) SIFS short interframe space
- b) PIFS PCF interframe space
- c) DIFS DCF interframe space
- d) EIFS extended interframe space

The different IFSs shall be independent of the STA bit rate. The IFS timings shall be defined as time gaps on the medium, and shall be fixed for each PHY (even in multirate-capable PHYs). The IFS values are determined from attributes specified by the PHY.

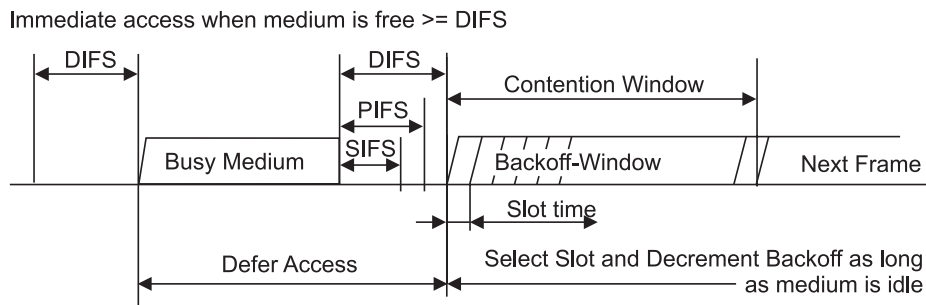

Figure 49—Some IFS relationships

#### 9.2.3.1 Short IFS (SIFS)

The SIFS shall be used for an ACK frame, a CTS frame, the second or subsequent MPDU of a fragment burst, and by a STA responding to any polling by the PCF. It may also be used by a PC for any types of frames during the CFP (see 9.3). The SIFS is the time from the end of the last symbol of the previous frame to the beginning of the first symbol of the preamble of the subsequent frame as seen at the air interface. The valid cases where the SIFS may or shall be used are listed in the frame exchange sequences in 9.7.

The SIFS timing shall be achieved when the transmission of the subsequent frame is started at the TxSIFS Slot boundary as specified in 9.2.10. An IEEE 802.11 implementation shall not allow the space between frames that are defined to be separated by a SIFS time, as measured on the medium, to vary from the nominal SIFS value by more than  $\pm 10\%$  of aSlotTime for the PHY in use.

SIFS is the shortest of the interframe spaces. SIFS shall be used when STAs have seized the medium and need to keep it for the duration of the frame exchange sequence to be performed. Using the smallest gap between transmissions within the frame exchange sequence prevents other STAs, which are required to wait for the medium to be idle for a longer gap, from attempting to use the medium, thus giving priority to completion of the frame exchange sequence in progress.

#### 9.2.3.2 PCF IFS (PIFS)

The PIFS shall be used only by STAs operating under the PCF to gain priority access to the medium at the start of the CFP. A STA using the PCF shall be allowed to transmit contention-free traffic after its carrier-sense mechanism (see 9.2.1) determines that the medium is idle at the TxPIFS slot boundary as defined in 9.2.10. Subclause 9.3 describes the use of the PIFS by STAs operating under the PCF.

### 9.2.3.3 DCF IFS (DIFS)

The DIFS shall be used by STAs operating under the DCF to transmit data frames (MPDUs) and management frames (MMPDUs). A STA using the DCF shall be allowed to transmit if its carrier-sense mechanism (see 9.2.1) determines that the medium is idle at the TxDIFS slot boundary as defined in 9.2.10 after a correctly received frame, and its backoff time has expired. A STA using the DCF shall not transmit within an EIFS after it determines that the medium is idle following reception of a frame for which the PHYRX-END.indication primitive contained an error or a frame for which the MAC FCS value was not correct. A STA may transmit after subsequent reception of an error-free frame, resynchronizing the STA. This allows the STA to transmit using the DIFS following that frame.

### 9.2.3.4 Extended IFS (EIFS)

The EIFS shall be used by the DCF whenever the PHY has indicated to the MAC that a frame transmission was begun that did not result in the correct reception of a complete MAC frame with a correct FCS value. The duration of an EIFS is defined in 9.2.10. The EIFS interval shall begin following indication by the PHY that the medium is idle after detection of the erroneous frame, without regard to the virtual carrier-sense mechanism. The EIFS is defined to provide enough time for another STA to acknowledge what was, to this STA, an incorrectly received frame before this STA commences transmission. Reception of an error-free frame during the EIFS resynchronizes the STA to the actual busy/idle state of the medium, so the EIFS is terminated and normal medium access (using DIFS and, if necessary, backoff) continues following reception of that frame.

### 9.2.4 Random backoff time

A STA desiring to initiate transfer of data MPDUs and/or management MMPDUs shall invoke the carrier-sense mechanism (see 9.2.1) to determine the busy/idle state of the medium. If the medium is busy, the STA shall defer until the medium is determined to be idle without interruption for a period of time equal to DIFS when the last frame detected on the medium was received correctly, or after the medium is determined to be idle without interruption for a period of time equal to EIFS when the last frame detected on the medium was not received correctly. After this DIFS or EIFS medium idle time, the STA shall then generate a random backoff period for an additional deferral time before transmitting, unless the backoff timer already contains a nonzero value, in which case the selection of a random number is not needed and not performed. This process minimizes collisions during contention between multiple STAs that have been deferring to the same event.

$$\text{Backoff Time} = \text{Random}() \times \text{aSlotTime}$$

where

Random() = Pseudorandom integer drawn from a uniform distribution over the interval [0,CW], where CW is an integer within the range of values of the PHY characteristics aCWmin and aCWmax,  $\text{aCWmin} \leq \text{CW} \leq \text{aCWmax}$ . It is important that designers recognize the need for statistical independence among the random number streams among STAs.

aSlotTime = The value of the correspondingly named PHY characteristic.

The contention window (CW) parameter shall take an initial value of aCWmin. Every STA shall maintain a STA short retry count (SSRC) as well as a STA long retry count (SLRC), both of which shall take an initial value of zero. The SSRC shall be incremented whenever any short retry count associated with any MSDU is incremented. The SLRC shall be incremented whenever any long retry count associated with any MSDU is incremented. The CW shall take the next value in the series every time an unsuccessful attempt to transmit an MPDU causes either STA retry counter to increment, until the CW reaches the value of aCWmax. A retry is defined as the entire sequence of frames sent, separated by SIFS intervals, in an attempt to deliver an MPDU, as described in 9.7. Once it reaches aCWmax, the CW shall remain at the value of aCWmax until it is reset. This improves the stability of the access protocol under high-load conditions. See Figure 50.

The CW shall be reset to aCWmin after every successful attempt to transmit an MSDU or MMPDU, when SLRC reaches aLongRetryLimit, or when SSRC reaches dot11ShortRetryLimit. The SSRC shall be reset to 0 whenever a CTS frame is received in response to an RTS frame, whenever an ACK frame is received in response to an MPDU or MMPDU transmission, or whenever a frame with a group address in the Address1 field is transmitted. The SLRC shall be reset to 0 whenever an ACK frame is received in response to transmission of an MPDU or MMPDU of length greater than dot11RTSThreshold, or whenever a frame with a group address in the Address1 field is transmitted.

The set of CW values shall be sequentially ascending integer powers of 2, minus 1, beginning with a PHY-specific aCWmin value, and continuing up to and including a PHY-specific aCWmax value.

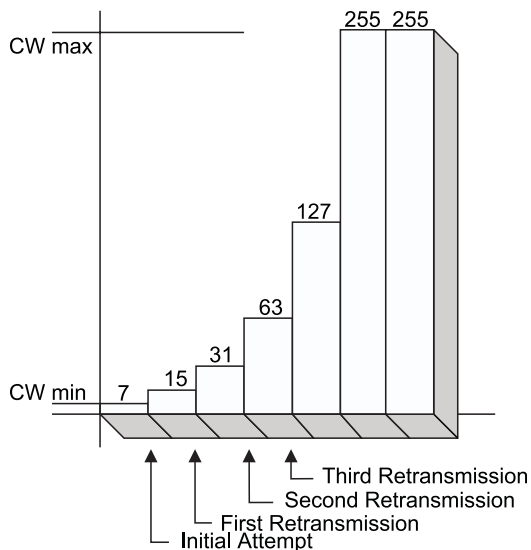

**Figure 50—An example of exponential increase of CW**

## 9.2.5 DCF access procedure

The CSMA/CA access method is the foundation of the DCF. The operational rules vary slightly between the DCF and the PCF.

### 9.2.5.1 Basic access

Basic access refers to the core mechanism a STA uses to determine whether it may transmit.

In general, a STA may transmit a pending MPDU when it is operating under the DCF access method, either in the absence of a PC, or in the CP of the PCF access method, when the STA determines that the medium is idle for greater than or equal to a DIFS period, or an EIFS period if the immediately preceding medium-busy event was caused by detection of a frame that was not received at this STA with a correct MAC FCS value. If, under these conditions, the medium is determined by the carrier-sense mechanism to be busy when a STA desires to initiate the initial frame of one of the frame exchanges described in 9.7, exclusive of the CF period, the random backoff algorithm described in 9.2.5.2 shall be followed. There are conditions, specified in 9.2.5.2 and 9.2.5.5, where the random backoff algorithm shall be followed even for the first attempt to initiate a frame exchange sequence.

In a STA having an FH PHY, control of the channel is lost at the dwell time boundary and the STA shall have to contend for the channel after that dwell boundary. It is required that STAs having an FH PHY complete transmission of the entire MPDU and associated acknowledgment (if required) before the dwell time bound-

ary. If, when transmitting or retransmitting an MPDU, there is not enough time remaining in the dwell to allow transmission of the MPDU plus the acknowledgment (if required), the STA shall defer the transmission by selecting a random backoff time, using the present CW (without advancing to the next value in the series). The short retry counter and long retry counter for the MSDU are not affected.

The basic access mechanism is illustrated in Figure 51.

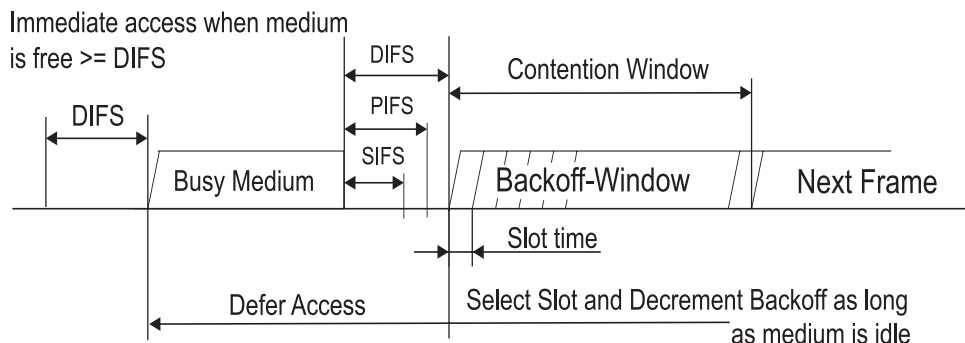

**Figure 51—Basic access method**

### 9.2.5.2 Backoff procedure

The backoff procedure shall be invoked for a STA to transfer a frame when finding the medium busy as indicated by either the physical or virtual carrier-sense mechanism (see Figure 52). The backoff procedure shall also be invoked when a transmitting STA infers a failed transmission as defined in 9.2.5.7 or 9.2.8.

To begin the backoff procedure, the STA shall set its Backoff Timer to a random backoff time using the equation in 9.2.4. All backoff slots occur following a DIFS period during which the medium is determined to be idle for the duration of the DIFS period, or following an EIFS period during which the medium is determined to be idle for the duration of the EIFS period following detection of a frame that was not received correctly.

A STA performing the backoff procedure shall use the carrier-sense mechanism (9.2.1) to determine whether there is activity during each backoff slot. If no medium activity is indicated for the duration of a particular backoff slot, then the backoff procedure shall decrement its backoff time by aSlotTime.

If the medium is determined to be busy at any time during a backoff slot, then the backoff procedure is suspended; that is, the backoff timer shall not decrement for that slot. The medium shall be determined to be idle for the duration of a DIFS period or EIFS, as appropriate (see 9.2.3), before the backoff procedure is allowed to resume. Transmission shall commence whenever the Backoff Timer reaches zero.

A backoff procedure shall be performed immediately after the end of every transmission with the More Fragments bit set to 0 of an MPDU of type Data, Management, or Control with subtype PS-Poll, even if no additional transmissions are currently queued. In the case of successful acknowledged transmissions, this backoff procedure shall begin at the end of the received ACK frame. In the case of unsuccessful transmissions requiring acknowledgment, this backoff procedure shall begin at the end of the ACK timeout interval. If the transmission is successful, the CW value reverts to aCW<sub>min</sub> before the random backoff interval is chosen, and the STA short retry count and/or STA long retry count are updated as described in 9.2.4. This assures that transmitted frames from a STA are always separated by at least one backoff interval.

The effect of this procedure is that when multiple STAs are deferring and go into random backoff, then the STA selecting the smallest backoff time using the random function will win the contention.

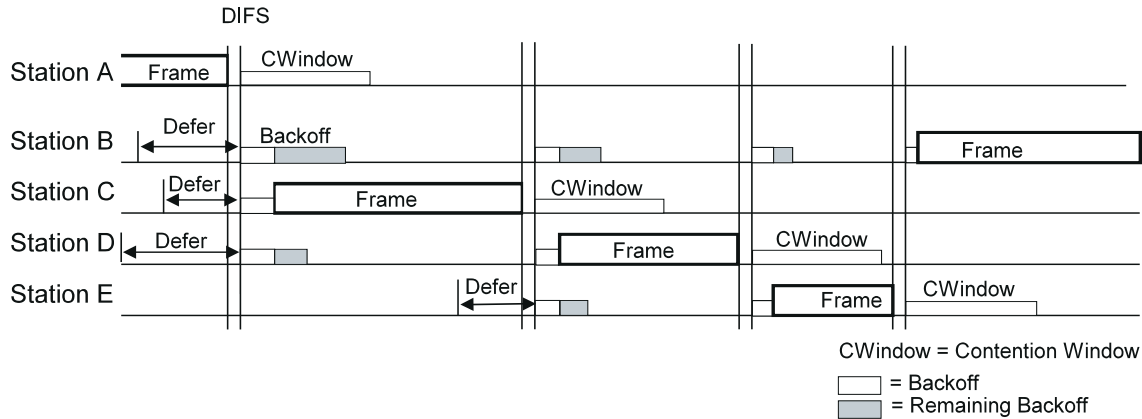

**Figure 52—Backoff procedure**

In an IBSS, the backoff time for a pending non-beacon or non-ATIM transmission shall not decrement in the period from the target beacon transmission time (TBTT) until the expiration of the ATIM window, and the backoff time for a pending ATIM management frame shall decrement only within the ATIM window. (See Clause 11.) Within an IBSS, a separate backoff interval shall be generated to precede the transmission of a beacon, as described in 11.1.2.2.

### 9.2.5.3 Recovery procedures and retransmit limits

Error recovery is always the responsibility of the STA that initiates a frame exchange sequence, as defined in 9.7. Many circumstances may cause an error to occur that requires recovery. For example, the CTS frame may not be returned after an RTS frame is transmitted. This may happen due to a collision with another transmission, due to interference in the channel during the RTS or CTS frame, or because the STA receiving the RTS frame has an active virtual carrier-sense condition (indicating a busy medium time period).

Error recovery shall be attempted by retrying transmissions for frame exchange sequences that the initiating STA infers have failed. Retries shall continue, for each failing frame exchange sequence, until the transmission is successful, or until the relevant retry limit is reached, whichever occurs first. STAs shall maintain a short retry count and a long retry count for each MSDU or MMPDU awaiting transmission. These counts are incremented and reset independently of each other.

After an RTS frame is transmitted, the STA shall perform the CTS procedure, as defined in 9.2.5.7. If the RTS transmission fails, the short retry count for the MSDU or MMPDU and the STA short retry count are incremented. This process shall continue until the number of attempts to transmit that MSDU or MMPDU reaches `dot11ShortRetryLimit`.

After transmitting a frame that requires acknowledgment, the STA shall perform the ACK procedure, as defined in 9.2.8. The short retry count for an MSDU or MMPDU and the STA short retry count shall be incremented every time transmission of a MAC frame of length less than or equal to `dot11RTSThreshold` fails for that MSDU or MMPDU. This short retry count and the STA short retry count shall be reset when a MAC frame of length less than or equal to `dot11RTSThreshold` succeeds for that MSDU or MMPDU. The long retry count for an MSDU or MMPDU and the STA long retry count shall be incremented every time transmission of a MAC frame of length greater than `dot11RTSThreshold` fails for that MSDU or MMPDU. This long retry count and the STA long retry count shall be reset when a MAC frame of length greater than `dot11RTSThreshold` succeeds for that MSDU or MMPDU. All retransmission attempts for an MSDU or MMPDU that has failed the ACK procedure one or more times shall be made with the Retry field set to 1 in the Data or Management type frame.

Retries for failed transmission attempts shall continue until the short retry count for the MSDU or MMPDU is equal to dot11ShortRetryLimit or until the long retry count for the MSDU or MMPDU is equal to aLongRetryLimit. When either of these limits is reached, retry attempts shall cease, and the MSDU or MMPDU shall be discarded.

A STA in power-save mode, in an ESS, initiates a frame exchange sequence by transmitting a PS-Poll frame to request data from an AP. In the event that neither an ACK frame nor a data frame is received from the AP in response to a PS-Poll frame, then the STA shall retry the sequence, by transmitting another PS-Poll frame, at its convenience. If the AP sends a data frame in response to a PS-Poll frame, but fails to receive the ACK frame acknowledging this data frame, the next PS-Poll frame from the same STA may cause a retransmission of the last MSDU. This duplicate MSDU shall be filtered at the receiving STA using the normal duplicate frame filtering mechanism. If the AP responds to a PS-Poll by transmitting an ACK frame, then responsibility for the data frame delivery error recovery shifts to the AP because the data is transferred in a subsequent frame exchange sequence, which is initiated by the AP. The AP shall attempt to deliver one MSDU to the STA that transmitted the PS-Poll, using any frame exchange sequence valid for a directed MSDU. If the power save STA that transmitted the PS-Poll returns to Doze state after transmitting the ACK frame in response to successful receipt of this MSDU, but the AP fails to receive this ACK frame, the AP will retry transmission of this MSDU until the relevant retry limit is reached. See Clause 11 for details on filtering of extra PS-Poll frames.

### 9.2.5.4 Setting and resetting the NAV

STAs receiving a valid frame shall update their NAV with the information received in the Duration/ID field, but only when the new NAV value is greater than the current NAV value and only when the frame is not addressed to the receiving STA. Various additional conditions may set or reset the NAV, as described in 9.3.2.2. When the NAV is reset, a PHY-CCARESET.request shall be issued.

Figure 53 indicates the NAV for STAs that may receive the RTS frame, while other STAs may only receive the CTS frame, resulting in the lower NAV bar as shown (with the exception of the STA to which the RTS was addressed).

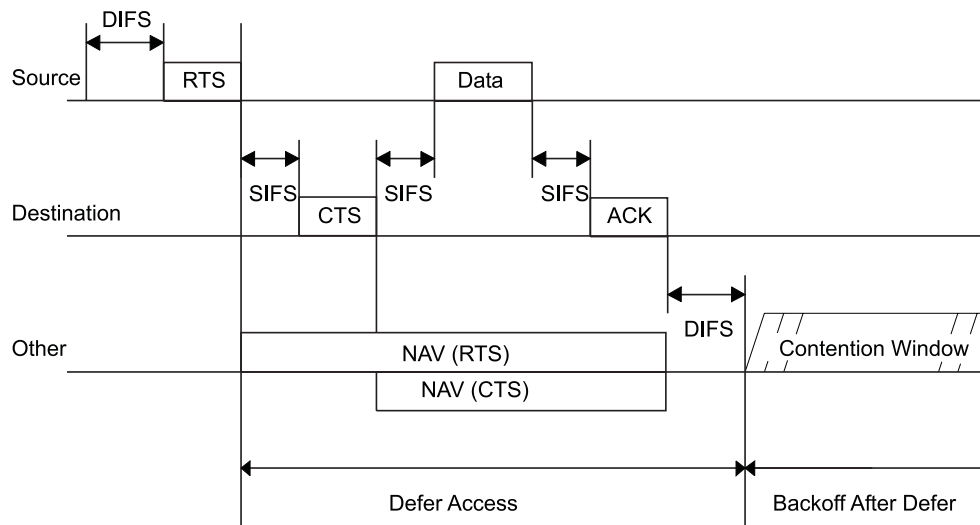

Figure 53—RTS/CTS/data/ACK and NAV setting

A STA that used information from an RTS frame as the most recent basis to update its NAV setting is permitted to reset its NAV if no PHY-RXSTART.indication is detected from the PHY during a period with a duration of  $(2 \times aSIFSTime) + (CTS\_Time) + (2 \times aSlotTime)$  starting at the PHY-RXEND.indication corresponding to the detection of the RTS frame. The “CTS\_Time” shall be calculated using the length of the CTS frame and the data rate at which the RTS frame used for the most recent NAV update was received.



### 9.2.5.5 Control of the channel

The SIFS is used to provide an efficient MSDU delivery mechanism. Once the STA has contended for the channel, that STA shall continue to send fragments until either all fragments of a single MSDU or MMPDU have been sent, an acknowledgment is not received, or the STA is restricted from sending any additional fragments due to a dwell time boundary. Should the sending of the fragments be interrupted due to one of these reasons, when the next opportunity for transmission occurs the STA shall resume transmission. The algorithm by which the STA decides which of the outstanding MSDUs shall next be attempted after an unsuccessful transmission attempt is beyond the scope of this standard, but any such algorithm shall comply with the restrictions listed in 9.8.

Figure 54 illustrates the transmission of a multiple-fragment MSDU using the SIFS.

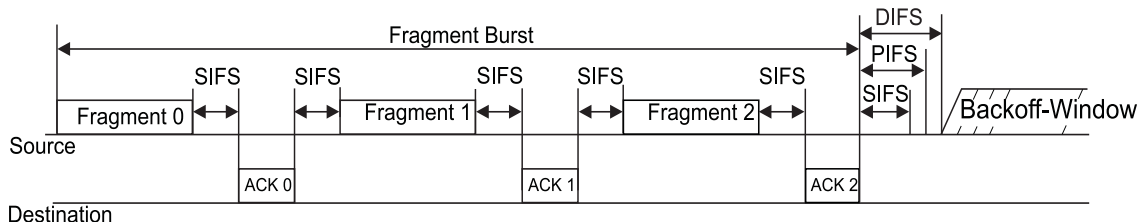

**Figure 54—Transmission of a multiple-fragment MSDU using SIFS**

When the source STA transmits a fragment, it shall release the channel, then immediately monitor the channel for an acknowledgment as described in 9.2.8.

When the destination STA has finished sending the acknowledgment, the SIFS following the acknowledgment shall be reserved for the source STA to continue (if necessary) with another fragment. The STA sending the acknowledgment shall not transmit on the channel immediately following the acknowledgment.

The process of sending multiple fragments after contending for the channel is defined as a fragment burst.

If the source STA receives an acknowledgment but there is not enough time to transmit the next fragment and receive an acknowledgment due to an impending dwell boundary, the source STA shall contend for the channel at the beginning of the next dwell time.

If the source STA does not receive an acknowledgment frame, it shall attempt to retransmit the failed MPDU or another eligible MPDU, as defined in 9.8, after performing the backoff procedure and the contention process.

After a STA contends for the channel to retransmit a fragment of an MSDU, it shall start with the last fragment that was not acknowledged. The destination STA shall receive the fragments in order (since the source sends them in order, and they are individually acknowledged). It is possible, however, that the destination STA may receive duplicate fragments. It shall be the responsibility of the receiving STA to detect and discard duplicate fragments.

A STA shall transmit after the SIFS only under the following conditions during a fragment burst:

- The STA has just received a fragment that requires acknowledgment.

- The source STA has received an acknowledgment for a previous fragment, has more fragment(s) for the same MSDU to transmit, and there is enough time before the next dwell boundary to send the next fragment and receive its acknowledgment.

The following rules shall also apply:

- When a STA has transmitted a frame other than an initial or intermediate fragment, that STA shall not transmit on the channel following the acknowledgment for that frame, without performing the backoff procedure.
- When an MSDU has been successfully delivered or all retransmission attempts have been exhausted, and the STA has a subsequent MSDU to transmit, then that STA shall perform a backoff procedure.
- Only unacknowledged fragments shall be retransmitted.

### 9.2.5.6 RTS/CTS usage with fragmentation

The following is a description of using RTS/CTS for a fragmented MSDU or MMPDU. The RTS/CTS frames define the duration of the following frame and acknowledgment. The Duration/ID field in the data and acknowledgment (ACK) frames specifies the total duration of the next fragment and acknowledgment. This is illustrated in Figure 55.

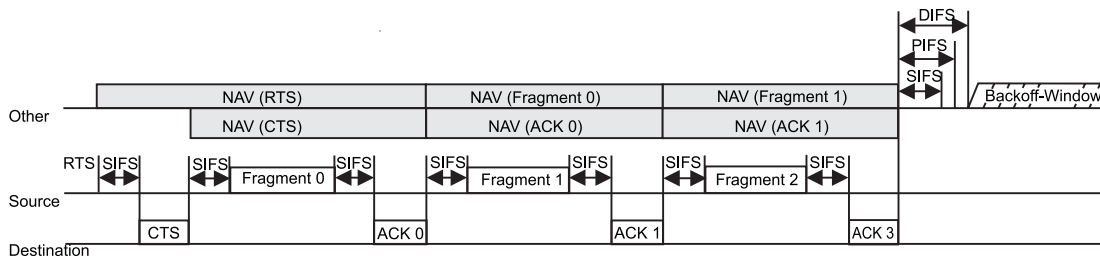

**Figure 55—RTS/CTS with fragmented MSDU**

Each frame contains information that defines the duration of the next transmission. The duration information from RTS frames shall be used to update the NAV to indicate busy until the end of ACK 0. The duration information from the CTS frame shall also be used to update the NAV to indicate busy until the end of ACK 0. Both Fragment 0 and ACK 0 shall contain duration information to update the NAV to indicate busy until the end of ACK 1. This shall be done by using the Duration/ID field in the Data and ACK frames. This shall continue until the last fragment, which shall have a duration of one ACK time plus one SIFS time, and its ACK, which shall have its Duration/ID field set to zero. Each fragment and ACK acts as a virtual RTS and CTS; therefore no further RTS/CTS frames need to be generated after the RTS/CTS that began the frame exchange sequence even though subsequent fragments may be larger than dot11RTSThreshold. At STAs using a frequency-hopping PHY, when there is insufficient time before the next dwell boundary to transmit the subsequent fragment, the STA initiating the frame exchange sequence may set the Duration/ID field in the last data or management frame to be transmitted before the dwell boundary to the duration of one ACK time plus one SIFS time.

In the case where an acknowledgment is sent but not received by the source STA, STAs that heard the fragment, or ACK, will mark the channel busy for the next frame exchange due to the NAV having been updated from these frames. This is the worst-case situation, and it is shown in Figure 56. If an acknowledgment is not sent by the destination STA, STAs that can only hear the destination STA will not update their NAV and may attempt to access the channel when their NAV updated from the previously received frame reaches zero. All STAs that hear the source will be free to access the channel after their NAV updated from the transmitted fragment has expired.

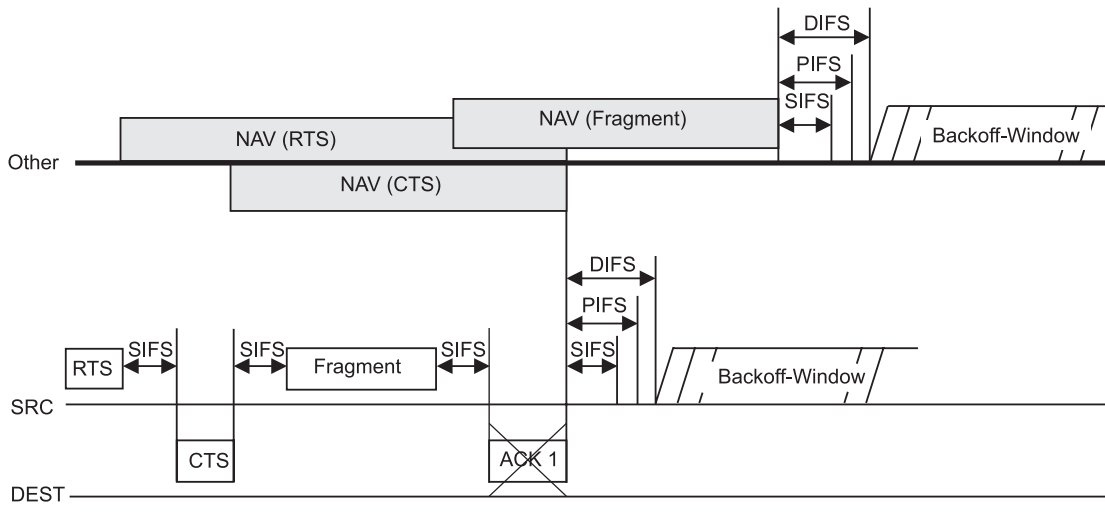

Figure 56—RTS/CTS with transmitter priority and missed acknowledgment

### 9.2.5.7 CTS procedure

A STA that is addressed by an RTS frame shall transmit a CTS frame after a SIFS period if the NAV at the STA receiving the RTS frame indicates that the medium is idle. If the NAV at the STA receiving the RTS frame indicates the medium is not idle, that STA shall not respond to the RTS frame. The RA field of the CTS frame shall be the value obtained from the TA field of the RTS frame to which this CTS frame is a response. The Duration/ID field in the CTS frame shall be the duration field from the received RTS frame, adjusted by subtraction of aSIFSTime and the number of microseconds required to transmit a CTS frame at the data rate used for the RTS frame to which this CTS frame is a response.

After transmitting an RTS frame, the STA shall wait for a CTSTimeout interval, starting at the PHY-TXEND.confirm. If a PHY-RXSTART.indication does not occur during the CTSTimeout interval, the STA shall conclude that the transmission of the RTS has failed, and this STA shall invoke its backoff procedure upon expiration of the CTSTimeout interval. If a PHY-RXSTART.indication does occur during the CTSTimeout interval, the STA shall wait for the corresponding PHY-RXEND.indication to determine whether the RTS transmission was successful. The recognition of a valid CTS frame sent by the recipient of the RTS frame, corresponding to this PHY-RXEND.indication, shall be interpreted as successful response, permitting the frame sequence to continue (see 9.7). The recognition of anything else, including any other valid frame, shall be interpreted as failure of the RTS transmission. In this instance, the STA shall invoke its backoff procedure at the PHY-RXEND.indication and may process the received frame.

### 9.2.6 Directed MPDU transfer procedure

A STA shall use an RTS/CTS exchange for directed frames only when the length of the MPDU is greater than the length threshold indicated by the dot11RTSThreshold attribute.

The dot11RTSThreshold attribute shall be a managed object within the MAC MIB, and its value may be set and retrieved by the MAC LME. The value 0 shall be used to indicate that all MPDUs shall be delivered with the use of RTS/CTS. Values of dot11RTSThreshold larger than the maximum MSDU length shall indicate that all MPDUs shall be delivered without RTS/CTS exchanges.

When an RTS/CTS exchange is used, the asynchronous data frame shall be transmitted after the end of the CTS frame and a SIFS period. No regard shall be given to the busy or idle status of the medium when transmitting this data frame.

When an RTS/CTS exchange is not used, the asynchronous data frame shall be transmitted following the success of the basic access procedure. With or without the use of the RTS/CTS exchange procedure, the STA that is the destination of an asynchronous data frame shall follow the ACK procedure.

### 9.2.7 Broadcast and multicast MPDU transfer procedure

In the absence of a PCF, when broadcast or multicast MPDUs are transferred from a STA with the ToDS bit clear, only the basic access procedure shall be used. Regardless of the length of the frame, no RTS/CTS exchange shall be used. In addition, no ACK shall be transmitted by any of the recipients of the frame. Any broadcast or multicast MPDUs transferred from a STA with a ToDS bit set shall, in addition to conforming to the basic access procedure of CSMA/CA, obey the rules for RTS/CTS exchange, because the MPDU is directed to the AP. The broadcast/multicast message shall be distributed into the BSS. The STA originating the message shall receive the message as a broadcast/multicast message. Therefore, all STAs shall filter out broadcast/multicast messages that contain their address as the source address. Broadcast and multicast MSDUs shall be propagated throughout the ESS.

There is no MAC-level recovery on broadcast or multicast frames, except for those frames sent with the ToDS bit set. As a result, the reliability of this traffic is reduced, relative to the reliability of directed traffic, due to the increased probability of lost frames from interference, collisions, or time-varying channel properties.

### 9.2.8 ACK procedure

An ACK frame shall be generated as shown in the frame exchange sequences listed in 9.7.

Upon successful reception of a frame of a type that requires acknowledgment with the ToDS bit set, an AP shall generate an ACK frame. An ACK frame shall be transmitted by the destination STA that is not an AP, whenever it successfully receives a unicast frame of a type that requires acknowledgment, but not if it receives a broadcast or multicast frame of such type. After a successful reception of a frame requiring acknowledgment, transmission of the ACK frame shall commence after a SIFS period, without regard to the busy/idle state of the medium.

The source STA shall wait ACKTimeout amount of time without receiving an ACK frame before concluding that the MPDU failed. (See Figure 57.)

After transmitting an MPDU that requires an ACK frame as a response (see 9.7), the STA shall wait for an ACK-Timeout interval, starting at the PHY-TXEND.confirm. If a PHY-RXSTART.indication does not occur during the ACKTimeout interval, the STA concludes that the transmission of the MPDU has failed, and this STA shall invoke its backoff procedure upon expiration of the ACKTimeout interval. If a PHY-RXSTART.indication does occur during the ACKTimeout interval, the STA shall wait for the corresponding PHY-RXEND.indication to determine whether the MPDU transmission was successful. The recognition of a valid ACK frame sent by the recipient of the MPDU requiring acknowledgment, corresponding to this PHY-RXEND.indication, shall be interpreted as successful acknowledgment, permitting the frame sequence to continue, or to end without retries, as appropriate for the particular frame sequence in progress. The recognition of anything else, including any other valid frame, shall be interpreted as failure of the MPDU transmission. In this instance, the STA shall invoke its backoff procedure at the PHY-RXEND.indication and may process the received frame. The sole exception is that recognition of a valid data frame sent by the recipient of a PS-Poll frame shall also be accepted as successful acknowledgment of the PS-Poll frame.

### 9.2.9 Duplicate detection and recovery

Since MAC-level acknowledgments and retransmissions are incorporated into the protocol, there is the possibility that a frame may be received more than once. Such duplicate frames shall be filtered out within the destination MAC.

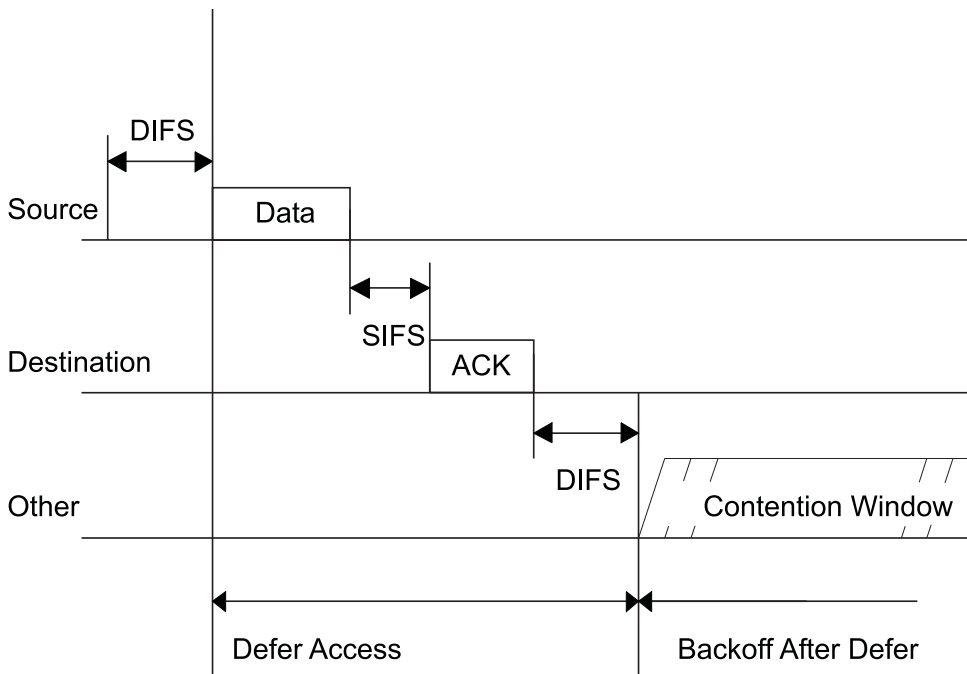

**Figure 57—Directed data/ACK MPDU**

Duplicate frame filtering is facilitated through the inclusion of a Sequence Control field (consisting of a sequence number and fragment number) within data and management frames. MPDUs that are part of the same MSDU shall have the same sequence number, and different MSDUs shall (with a high probability) have a different sequence number.

The sequence number is generated by the transmitting STA as an incrementing sequence of integers.

The receiving STA shall keep a cache of recently received <Address 2, sequence-number, fragment-number> tuples. A receiving STA is required to keep only the most recent cache entry per Address 2-sequence-number pair, storing only the most recently received fragment number for that pair. A receiving STA may omit tuples obtained from broadcast/multicast or ATIM frames from the cache.

A destination STA shall reject as a duplicate frame any frame that has the Retry bit set in the Frame Control field and that matches an <Address 2, sequence-number, and fragment-number> tuple of an entry in the cache.

There is a small possibility that a frame may be improperly rejected due to such a match; however, this occurrence would be rare and simply results in a lost frame (similar to an FCS error in other LAN protocols).

The destination STA shall perform the ACK procedure on all successfully received frames requiring acknowledgment, even if the frame is discarded due to duplicate filtering.

### 9.2.10 DCF timing relations

The relationships between the IFS specifications are defined as time gaps on the medium. The associated attributes are provided by the specific PHY. (See Figure 58.)

All timings that are referenced from the end of the transmission are referenced from the end of the last symbol of a frame on the medium. The beginning of transmission refers to the first symbol of the next frame on the medium.

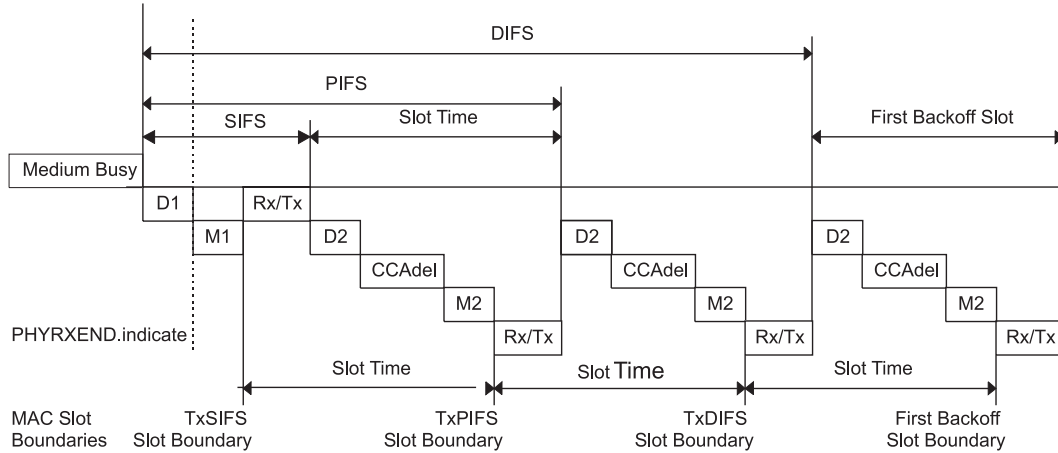

D1 = aRxRFDelay + aRxPLCPDelay (referenced from the end of the last symbol of a frame on the medium)  
D2 = D1 + Air Propagation Time  
Rx/Tx = aRXTXTurnaroundTime (begins with a PHYTXSTART.request)  
M1 = M2 = aMACPrdDelay  
CCAdel = aCCA Time - D1

**Figure 58—DCF timing relationships**

aSIFSTime and aSlotTime are fixed per PHY.

aSIFSTime is: aRxRFDelay + aRxPLCPDelay + aMACProcessingDelay + aRxTxTurnaroundTime.

aSlotTime is: aCCATime + aRxTxTurnaroundTime + aAirPropagationTime  
+ aMACProcessingDelay.

The PIFS and DIFS are derived by the following equations, as illustrated in Figure 58.

$$\text{PIFS} = \text{aSIFSTime} + \text{aSlotTime}$$

$$\text{DIFS} = \text{aSIFSTime} + 2 \times \text{aSlotTime}$$

The EIFS is derived from the SIFS and the DIFS and the length of time it takes to transmit an ACK Control frame at 1 Mbit/s by the following equation:

$$\text{EIFS} = \text{aSIFSTime} + (8 \times \text{ACKSize}) + \text{aPreambleLength} + \text{aPLCPHeaderLngth} + \text{DIFS}$$

where

ACKSize is the length, in bytes, of an ACK frame; and  
 $(8 \times \text{ACKSize}) + \text{aPreambleLength} + \text{aPLCPHeaderLngth}$  is expressed in microseconds required to transmit at the PHY's lowest mandatory rate.

Figure 58 illustrates the relation between the SIFS, PIFS, and DIFS as they are measured on the medium and the different MAC slot boundaries TxSIFS, TxPIFS, and TxDIFS. These slot boundaries define when the transmitter shall be turned on by the MAC to meet the different IFS timings on the medium, after subsequent detection of the CCA result of the previous slot time.