

FCC Test Report

Product Name	VoIP Phone
Model No.	UVP-Pro
FCC ID.	SWX-UVPPRO

Applicant	Ubiquiti Networks, Inc.
Address	12F, No. 105, Song Ren Rd., Sin Yi District, Taipei 110, Taiwan

Date of Receipt	Sep. 05, 2014
Issued Date	Nov. 14, 2014
Report No.	1490232R-RFUSP73V00-A
Report Version	V1.0



The test results relate only to the samples tested.

The test results shown in the test report are traceable to the national/international standard through the calibration report of the equipment and evaluated measurement uncertainty herein.

This report must not be used to claim product endorsement by TAF or any agency of the government.

The test report shall not be reproduced without the written approval of Quietek Corporation.

Test Report

Issued Date: Nov. 14, 2014

Report No.: 1490232R-RFUSP73V00-A



Product Name	VoIP Phone
Applicant	Ubiquiti Networks, Inc.
Address	12F, No. 105, Song Ren Rd., Sin Yi District, Taipei 110, Taiwan
Manufacturer	Ubiquiti Networks, Inc.
Model No.	UVP-Pro
FCC ID.	SWX-UVPPRO
EUT Rated Voltage	DC 48V (Power by POE)
EUT Test Voltage	AC 120V/ 60Hz
Trade Name	UBIQUITI
Applicable Standard	FCC CFR Title 47 Part 15 Subpart C: 2014 ANSI C63.10: 2009, KDB 558074 D01 DTS Meas Guidance v03r02
Test Result	Complied

Documented By : Rita Huang
(Senior Adm. Specialist / Rita Huang)

Tested By : Benjamin Pan
(Engineer / Benjamin Pan)

Approved By : Vincent Lin
(Director / Vincent Lin)

TABLE OF CONTENTS

Description	Page
1. GENERAL INFORMATION	4
1.1. EUT Description.....	4
1.2. Operational Description.....	6
1.3. Tested System Details.....	7
1.4. Configuration of Tested System	7
1.5. EUT Exercise Software	7
1.6. Test Facility	8
2. CONDUCTED EMISSION	9
2.1. Test Equipment	9
2.2. Test Setup	9
2.3. Limits.....	10
2.4. Test Procedure	10
2.5. Uncertainty	10
2.6. Test Result of Conducted Emission.....	11
3. PEAK POWER OUTPUT	13
3.1. Test Equipment	13
3.2. Test Setup	13
3.3. Limit	13
3.4. Test Procedure	13
3.5. Uncertainty	13
3.6. Test Result of Peak Power Output	14
4. RADIATED EMISSION	15
4.1. Test Equipment	15
4.2. Test Setup	15
4.3. Limits.....	16
4.4. Test Procedure	17
4.5. Uncertainty	17
4.6. Test Result of Radiated Emission.....	18
5. RF ANTENNA CONDUCTED TEST	22
5.1. Test Equipment	22
5.2. Test Setup	22
5.3. Limits.....	22
5.4. Test Procedure	22
5.5. Uncertainty	22
5.6. Test Result of RF Antenna Conducted Test	23
6. BAND EDGE	24
6.1. Test Equipment	24
6.2. Test Setup	24
6.3. Limit	25
6.4. Test Procedure	25
6.5. Uncertainty	25
6.6. Test Result of Band Edge	26
7. OCCUPIED BANDWIDTH (6DB BW).....	30
7.1. Test Equipment	30
7.2. Test Setup	30
7.3. Limits.....	30
7.4. Test Procedure	30
7.5. Uncertainty	30
7.6. Test Result of Occupied Bandwidth	31
8. POWER DENSITY	34
8.1. Test Equipment	34
8.2. Test Setup	34
8.3. Limits.....	34
8.4. Test Procedure	34
8.5. Uncertainty	34
8.6. Test Result of Power Density	35
9. EMI REDUCTION METHOD DURING COMPLIANCE TESTING	38
Attachment 1: EUT Test Photographs	
Attachment 2: EUT Detailed Photographs	

1. GENERAL INFORMATION

1.1. EUT Description

Product Name	VoIP Phone
Trade Name	UBIQUITI
Model No.	UVP-Pro
FCC ID.	SWX-UVPPRO
Frequency Range	2402 – 2480MHz
Channel Number	V4.0: 40CH
Type of Modulation	V4.0: GFSK(1Mbps)
Antenna Type	Chip Antenna
Channel Control	Auto
Antenna Gain	Refer to the table “Antenna List”
Power Adapter	MFR: Ubiquiti, M/N: GP-B480-050G Input: 100-240V, 50/60Hz MAX 0.75A Output: 48V $\overline{\text{---}}$ 0.5A

Antenna List

No.	Manufacturer	Antenna Type	Peak Gain
1	TDK	Chip Antenna	2.27 dBi for 2.4 GHz

Note: The antenna of EUT is conforming to FCC 15.203.

Center Frequency of Each Channel: (For V4.0)

Channel	Frequency	Channel	Frequency	Channel	Frequency	Channel	Frequency
Channel 00:	2402 MHz	Channel 01:	2404 MHz	Channel 02:	2406 MHz	Channel 03:	2408 MHz
Channel 04:	2410 MHz	Channel 05:	2412 MHz	Channel 06:	2414 MHz	Channel 07:	2416 MHz
Channel 08:	2418 MHz	Channel 09:	2420 MHz	Channel 10:	2422 MHz	Channel 11:	2424 MHz
Channel 12:	2426 MHz	Channel 13:	2428 MHz	Channel 14:	2430 MHz	Channel 15:	2432 MHz
Channel 16:	2434 MHz	Channel 17:	2436 MHz	Channel 18:	2438 MHz	Channel 19:	2440 MHz
Channel 20:	2442 MHz	Channel 21:	2444 MHz	Channel 22:	2446 MHz	Channel 23:	2448 MHz
Channel 24:	2450 MHz	Channel 25:	2452 MHz	Channel 26:	2454 MHz	Channel 27:	2456 MHz
Channel 28:	2458 MHz	Channel 29:	2460 MHz	Channel 30:	2462 MHz	Channel 31:	2464 MHz
Channel 32:	2466 MHz	Channel 33:	2468 MHz	Channel 34:	2470 MHz	Channel 35:	2472 MHz
Channel 36:	2474 MHz	Channel 37:	2476 MHz	Channel 38:	2478 MHz	Channel 39:	2480 MHz

Note:

1. The EUT is a VoIP Phone with a built-in WLAN and Bluetooth transceiver, this report for Bluetooth V4.0.
2. These tests were conducted on a sample for the purpose of demonstrating compliance of Bluetooth transmitter with Part 15 Subpart C Paragraph 15.247 for spread spectrum devices.
3. Regarding to the operation frequency, the lowest, middle and highest frequency are selected to perform the test.

Test Mode	Mode 1: Transmit - BLE (GFSK)
-----------	-------------------------------

1.3. Tested System Details

The types for all equipment, plus descriptions of all cables used in the tested system (including inserted cards) are:

	Product	Manufacturer	Model No.	Serial No.	Power Cord
1	Notebook PC	DELL	PP18L	36119001664	Non-Shielded, 0.8m
2	POE	Ubiquiti	GP-B480-050	N/A	N/A
3	Earphone	Dr.AV	CD-806B	N/A	N/A

Signal Cable Type	Signal cable Description
A USB Cable	Shielded, 1.0m, with one ferrite core bonded.
B RJ45 Cable	Non-Shielded, 1.0m
C Earphone Cable	Non-Shielded, 1.0m
D RJ45 Cable	Non-Shielded, 2.0m, two PCS.

1.4. Configuration of Tested System

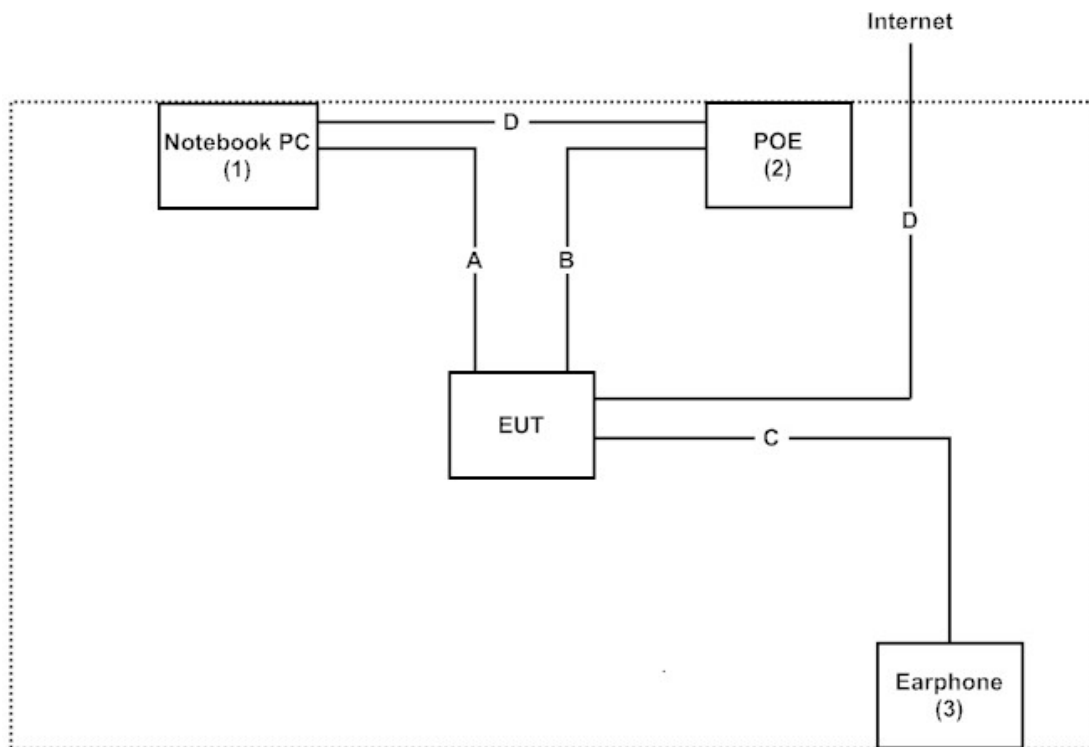

1.5. EUT Exercise Software

- 1 Setup the EUT as shown in Section 1.4.
- 2 Execute software “USI BCM FCC CE REG Tool V1.4.11” on the Notebook PC.
- 3 Configure the test mode, the test channel, and the data rate.
- 4 Press “OK” to start the continuous Transmit.
- 5 Verify that the EUT works properly.

1.6. Test Facility

Ambient conditions in the laboratory:

Items	Required (IEC 68-1)	Actual
Temperature (°C)	15-35	20-35
Humidity (%RH)	25-75	30-65
Barometric pressure (mbar)	860-1060	950-1000

The related certificate for our laboratories about the test site and management system can be downloaded from

QuieTek Corporation's Web Site: <http://www.quietek.com/tw/ctg/cts/accreditations.htm>

The address and introduction of QuieTek Corporation's laboratories can be founded in our Web site: <http://www.quietek.com/>

Site Description: File on
 Federal Communications Commission
 FCC Engineering Laboratory
 7435 Oakland Mills Road
 Columbia, MD 21046
 Registration Number: 92195

Site Name: Quietek Corporation
 Site Address: No.5-22, Ruishukeng,
 Linkou Dist. New Taipei City 24451,
 Taiwan, R.O.C.
 TEL: 886-2-8601-3788 / FAX : 886-2-8601-3789
 E-Mail : service@quietek.com

FCC Accreditation Number: TW1014

2. Conducted Emission

2.1. Test Equipment

	Equipment	Manufacturer	Model No. / Serial No.	Last Cal.	Remark
X	Test Receiver	R & S	ESCS 30 / 825442/018	Sep., 2014	
X	Artificial Mains Network	R & S	ENV4200 / 848411/10	Feb., 2014	Peripherals
X	LISN	R & S	ESH3-Z5 / 825562/002	Feb., 2014	EUT
	DC LISN	Schwarzbeck	8226 / 176	Mar., 2014	EUT
X	Pulse Limiter	R & S	ESH3-Z2 / 357.8810.52	Feb., 2014	
	No.1 Shielded Room				

Note:

1. All equipments are calibrated every one year.
2. The test instruments marked by “X” are used to measure the final test results.

2.2. Test Setup

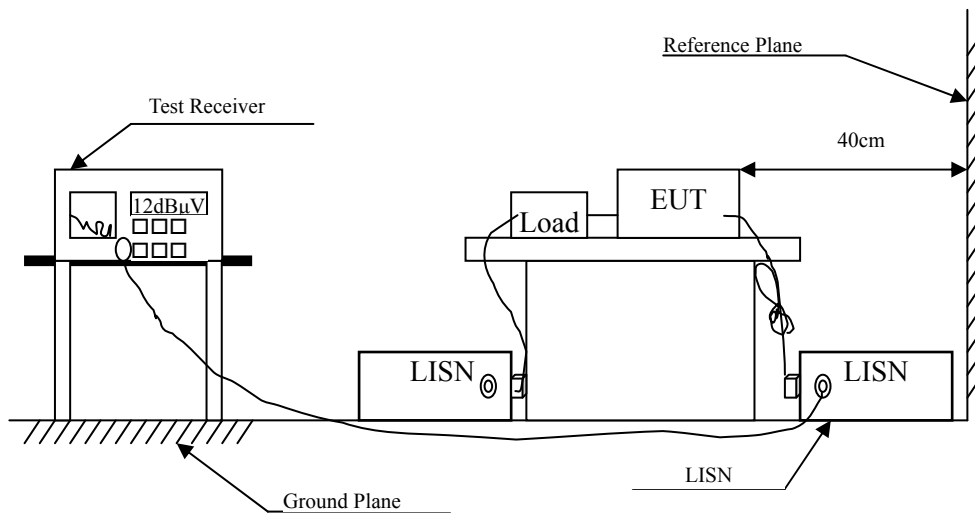

2.3. Limits

FCC Part 15 Subpart C Paragraph 15.207 (dBμV) Limit		
Frequency MHz	Limits	
	QP	AV
0.15 - 0.50	66-56	56-46
0.50-5.0	56	46
5.0 - 30	60	50

Remarks: In the above table, the tighter limit applies at the band edges.

2.4. Test Procedure

The EUT and Peripherals are connected to the main power through a line impedance stabilization network (L.I.S.N.). This provides a 50 ohm /50uH coupling impedance for the measuring equipment. The peripheral devices are also connected to the main power through a LISN that provides a 50ohm /50uH coupling impedance with 50ohm termination. (Please refer to the block diagram of the test setup and photographs.)

Both sides of A.C. line are checked for maximum conducted interference. In order to find the maximum emission, the relative positions of equipment and all the interface cables must be changed according to ANSI C63.10: 2009 on conducted measurement.

Conducted emissions were investigated over the frequency range from 0.15MHz to 30MHz using a receiver bandwidth of 9kHz.

The EUT was setup to ANSI C63.10, 2009; tested to FHSS test procedure of FCC Public Notice DA 00-705 for compliance to FCC 47CFR 15.247 requirements.

2.5. Uncertainty

± 2.26 dB

2.6. Test Result of Conducted Emission

Product : VoIP Phone
 Test Item : Conducted Emission Test
 Power Line : Line 1
 Test Mode : Mode 1: Transmit - BLE (GFSK) (2440MHz)

Frequency MHz	Correct Factor dB	Reading Level dBuV	Measurement Level dBuV	Margin dB	Limit dBuV
LINE 1					
Quasi-Peak					
0.158	9.747	34.680	44.427	-21.344	65.771
0.170	9.743	32.900	42.644	-22.785	65.429
0.212	9.739	28.440	38.179	-26.050	64.229
0.341	9.745	26.150	35.895	-24.648	60.543
0.505	9.753	33.100	42.853	-13.147	56.000
0.654	9.759	26.900	36.659	-19.341	56.000
Average					
0.158	9.747	26.160	35.907	-19.864	55.771
0.170	9.743	13.810	23.554	-31.875	55.429
0.212	9.739	20.420	30.159	-24.070	54.229
0.341	9.745	10.480	20.225	-30.318	50.543
0.505	9.753	21.420	31.173	-14.827	46.000
0.654	9.759	19.760	29.519	-16.481	46.000

Note:

1. All Reading Levels are Quasi-Peak and average value.
2. "■" means the worst emission level.
3. Measurement Level = Reading Level + Correct Factor

Product : VoIP Phone
 Test Item : Conducted Emission Test
 Power Line : Line 2
 Test Mode : Mode 1: Transmit - BLE (GFSK) (2440MHz)

Frequency MHz	Correct Factor dB	Reading Level dBuV	Measurement Level dBuV	Margin dB	Limit dBuV
LINE 2					
Quasi-Peak					
0.166	9.747	33.830	43.577	-21.966	65.543
0.212	9.749	28.580	38.329	-25.900	64.229
0.373	9.747	28.450	38.197	-21.432	59.629
0.498	9.752	32.750	42.502	-13.555	56.057
7.912	9.920	27.580	37.500	-22.500	60.000
21.162	10.105	25.840	35.945	-24.055	60.000
Average					
0.166	9.747	28.500	38.247	-17.296	55.543
0.212	9.749	24.300	34.049	-20.180	54.229
0.373	9.747	15.410	25.157	-24.472	49.629
0.498	9.752	28.740	38.492	-7.565	46.057
7.912	9.920	22.630	32.550	-17.450	50.000
21.162	10.105	20.160	30.265	-19.735	50.000

Note:

1. All Reading Levels are Quasi-Peak and average value.
2. "█" means the worst emission level.
3. Measurement Level = Reading Level + Correct Factor

3. Peak Power Output

3.1. Test Equipment

	Equipment	Manufacturer	Model No./Serial No.	Last Cal.
X	Power Meter	Anritsu	ML2495A/6K00003357	May, 2014
X	Power Sensor	Anritsu	MA2411B/0738448	Jun., 2014

Note: 1. All equipments are calibrated every one year.
 2. The test instruments marked by “X” are used to measure the final test results.

3.2. Test Setup

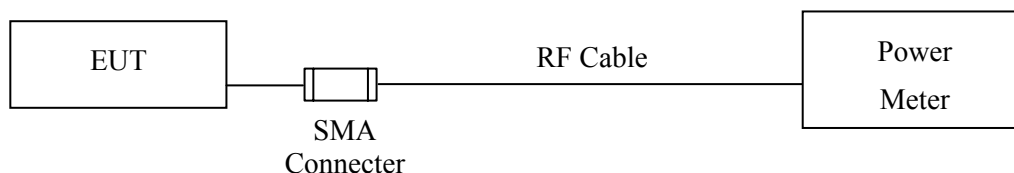

3.3. Limit

The maximum peak power shall be less 1Watt.

3.4. Test Procedure

Tested according to DTS test procedure of KDB 558074 for compliance to FCC 47CFR 15.247 requirements. The maximum peak conducted output power using KDB 558074 section 9.1.2 PKPM1 Peak power meter method.

3.5. Uncertainty

± 1.27 dB

3.6. Test Result of Peak Power Output

Product : VoIP Phone
 Test Item : Peak Power Output
 Test Site : No.3 OATS
 Test Mode : Mode 1: Transmit - BLE (GFSK)

Channel No.	Frequency (MHz)	Measurement (dBm)	Required Limit	Result
Channel 00	2402.00	0.38	1 Watt= 30 dBm	Pass
Channel 19	2440.00	1.08	1 Watt= 30 dBm	Pass
Channel 39	2480.00	1.03	1 Watt= 30 dBm	Pass

4. Radiated Emission

4.1. Test Equipment

The following test equipments are used during the radiated emission test:

Test Site	Equipment	Manufacturer	Model No./Serial No.	Last Cal.
☒ Site # 3	X Loop Antenna	Teseq	HLA6120 / 26739	Jul., 2014
	X Bilog Antenna	Schaffner Chase	CBL6112B/2673	Sep., 2014
	X Horn Antenna	Schwarzbeck	BBHA9120D/D305	Sep., 2014
	X Horn Antenna	Schwarzbeck	BBHA9170/208	Jul., 2014
	X Pre-Amplifier	Agilent	8447D/2944A09549	Sep., 2014
	X Spectrum Analyzer	Agilent	E4407B / US39440758	May, 2014
	X Test Receiver	R & S	ESCS 30/ 825442/018	Sep., 2014
	X Coaxial Cable	QuieTek	QTK-CABLE/ CAB5	Feb., 2014
	X Controller	QuieTek	QTK-CONTROLLER/ CTRL3	N/A
	X Coaxial Switch	Anritsu	MP59B/6200265729	N/A

- Note: 1. All equipments are calibrated every one year.
 2. The test instruments marked by "X" are used to measure the final test results.

4.2. Test Setup

Below 1GHz

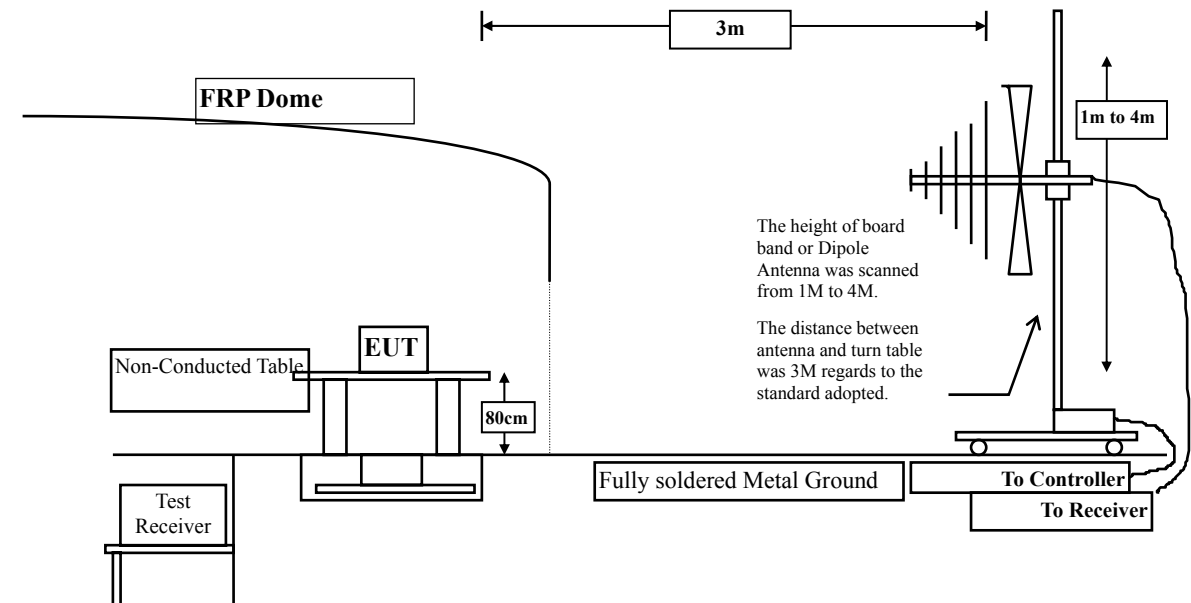

Above 1GHz

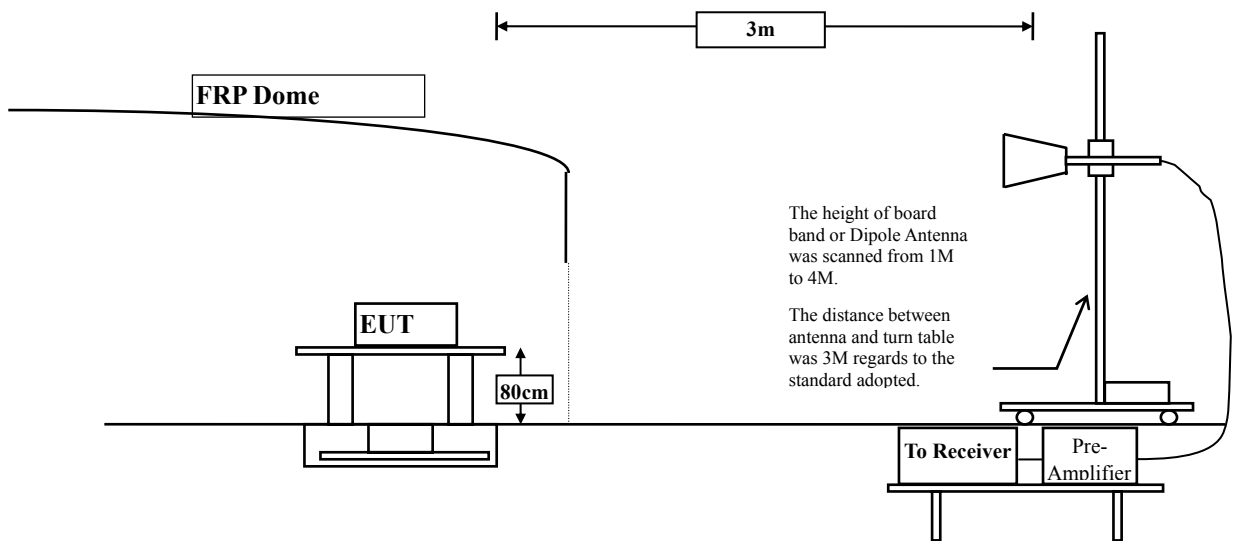

4.3. Limits

➤ **General Radiated Emission Limits**

Emissions radiated outside of the specified frequency bands, except for harmonics, shall be attenuated by at least 20dB below the level of the fundamental or to the general radiated emission limits in paragraph 15.209, whichever is the lesser attenuation.

FCC Part 15 Subpart C Paragraph 15.209 Limits		
Frequency MHz	Field strength (microvolts/meter)	Measurement distance (meter)
0.009-0.490	2400/F(kHz)	300
0.490-1.705	24000/F(kHz)	30
1.705-30	30	30
30-88	100	3
88-216	150	3
216-960	200	3
Above 960	500	3

- Remarks:
1. RF Voltage (dBμV) = 20 log RF Voltage (uV)
 2. In the Above Table, the tighter limit applies at the band edges.
 3. Distance refers to the distance in meters between the measuring instrument antenna and the closed point of any part of the device or system.

4.4. Test Procedure

The EUT was setup according to ANSI C63.10, 2009 and tested according to FHSS test procedure of FCC Public Notice DA 00-705 for compliance to FCC 47CFR 15.247 requirements.

The EUT is placed on a turn table which is 0.8 meter above ground. The turn table is rotated 360 degrees to determine the position of the maximum emission level. The EUT was positioned such that the distance from antenna to the EUT was 3 meters.

The antenna is scanned from 1 meter to 4 meters to find out the maximum emission level. This is repeated for both horizontal and vertical polarization of the antenna. In order to find the maximum emission, all of the interface cables were manipulated according to ANSI C63.10:2009 on radiated measurement.

The resolution bandwidth below 30MHz setting on the field strength meter is 9kHz and 30MHz~1GHz is 120kHz and above 1GHz is 1MHz.

Radiated emission measurements below 30MHz are made using Loop Antenna and 30MHz~1GHz are made using broadband Bilog antenna and above 1GHz are made using Horn Antennas.

The measurement is divided into the Preliminary Measurement and the Final Measurement.

The suspected frequencies are searched for in Preliminary Measurement with the measurement antenna kept pointed at the source of the emission both in azimuth and elevation, with the polarization of the antenna oriented for maximum response. The antenna is pointed at an angle towards the source of the emission, and the EUT is rotated in both height and polarization to maximize the measured emission. The emission is kept within the illumination area of the 3 dB bandwidth of the antenna.

The worst radiated emission is measured on the Final Measurement.

The measurement frequency range form 9kHz - 10th Harmonic of fundamental was investigated.

4.5. Uncertainty

± 3.9 dB above 1GHz

± 3.8 dB below 1GHz

4.6. Test Result of Radiated Emission

Product : VoIP Phone
 Test Item : Harmonic Radiated Emission
 Test Site : No.3 OATS
 Test Mode : Mode 1: Transmit - BLE (GFSK)(2402MHz)

Frequency MHz	Correct Factor dB	Reading Level dBμV	Measurement Level dBμV/m	Margin dB	Limit dBμV/m
Horizontal					
Peak Detector:					
4804.000	2.511	40.379	42.889	-31.111	74.000
7206.000	9.511	38.256	47.767	-26.233	74.000
9608.000	10.394	37.428	47.822	-26.178	74.000
Average Detector:					
--					
Vertical					
Peak Detector:					
4804.000	2.923	41.211	44.133	-29.867	74.000
7206.000	9.988	39.563	49.552	-24.448	74.000
9608.000	10.847	37.428	48.275	-25.725	74.000
Average Detector:					
--					

Note:

1. All Readings below 1GHz are Quasi-Peak, above 1GHz are performed with peak and/or average measurements as necessary.
2. Peak measurements: RBW = 1MHz, VBW = 3 MHz, Sweep: Auto.
3. Average measurements: RBW = 1MHz, VBW = 10 Hz, Sweep: Auto.
4. Measurement Level = Reading Level + Correct Factor.
5. Correct Factor = Antenna factor + Cable loss – Amplifier gain.
6. The average measurement was not performed when the peak measured data under the limit of average detection.
7. The emission levels of other frequencies are very lower than the limit and not show in test report.

Product : VoIP Phone
 Test Item : Harmonic Radiated Emission
 Test Site : No.3 OATS
 Test Mode : Mode 1: Transmit - BLE (GFSK) (2440MHz)

Frequency MHz	Correct Factor dB	Reading Level dBµV	Measurement Level dBµV/m	Margin dB	Limit dBµV/m
Horizontal					
Peak Detector:					
4880.000	2.038	42.417	44.455	-29.545	74.000
7320.000	9.699	37.872	47.571	-26.429	74.000
9760.000	9.665	37.670	47.335	-26.665	74.000
Average Detector:					
--					
Vertical					
Peak Detector:					
4880.000	2.499	43.288	45.787	-28.213	74.000
7320.000	10.303	38.874	49.177	-24.823	74.000
9760.000	10.299	37.703	48.003	-25.997	74.000
Average Detector:					
--					

Note:

1. All Readings below 1GHz are Quasi-Peak, above 1GHz are performed with peak and/or average measurements as necessary.
2. Peak measurements: RBW = 1MHz, VBW = 3 MHz, Sweep: Auto.
3. Average measurements: RBW = 1MHz, VBW = 10 Hz, Sweep: Auto.
4. Measurement Level = Reading Level + Correct Factor.
5. Correct Factor = Antenna factor + Cable loss –Amplifier gain.
6. The average measurement was not performed when the peak measured data under the limit of average detection.
7. The emission levels of other frequencies are very lower than the limit and not show in test report.

Product : VoIP Phone
 Test Item : Harmonic Radiated Emission
 Test Site : No.3 OATS
 Test Mode : Mode 1: Transmit - BLE (GFSK) (2480MHz)

Frequency MHz	Correct Factor dB	Reading Level dB μ V	Measurement Level dB μ V/m	Margin dB	Limit dB μ V/m
Horizontal					
Peak Detector:					
4960.000	2.582	43.263	45.845	-28.155	74.000
7440.000	10.555	37.745	48.300	-25.700	74.000
9920.000	10.206	37.083	47.289	-26.711	74.000
Average Detector:					
--					
Vertical					
Peak Detector:					
4960.000	3.398	45.027	48.426	-25.574	74.000
7440.000	11.214	37.525	48.739	-25.261	74.000
9920.000	11.245	37.990	49.235	-24.765	74.000
Average Detector:					
--					

Note:

1. All Readings below 1GHz are Quasi-Peak, above 1GHz are performed with peak and/or average measurements as necessary.
2. Peak measurements: RBW = 1MHz, VBW = 3 MHz, Sweep: Auto.
3. Average measurements: RBW = 1MHz, VBW = 10 Hz, Sweep: Auto.
4. Measurement Level = Reading Level + Correct Factor.
5. Correct Factor = Antenna factor + Cable loss – Amplifier gain.
6. The average measurement was not performed when the peak measured data under the limit of average detection.
7. The emission levels of other frequencies are very lower than the limit and not show in test report.

Product : VoIP Phone
 Test Item : General Radiated Emission
 Test Site : No.3 OATS
 Test Mode : Mode 1: Transmit - BLE (GFSK) (2440MHz)

Frequency MHz	Correct Factor dB	Reading Level dBμV	Measurement Level dBμV/m	Margin dB	Limit dBμV/m
Horizontal					
206.540	-10.529	49.300	38.771	-4.729	43.500
342.340	-2.566	41.548	38.982	-7.018	46.000
527.610	3.093	35.838	38.931	-7.069	46.000
624.610	1.507	35.490	36.997	-9.003	46.000
815.700	6.451	29.333	35.784	-10.216	46.000
911.730	6.471	31.590	38.061	-7.939	46.000
Vertical					
200.720	-5.676	45.261	39.585	-3.915	43.500
398.600	-2.371	41.182	38.811	-7.189	46.000
527.610	1.153	37.470	38.623	-7.377	46.000
601.330	1.463	33.927	35.390	-10.610	46.000
768.170	2.383	28.237	30.621	-15.379	46.000
911.730	0.241	34.487	34.728	-11.272	46.000

Note:

1. All Readings below 1GHz are Quasi-Peak, above 1GHz are performed with peak and/or average measurements as necessary.
2. Peak measurements: RBW = 1MHz, VBW = 3 MHz, Sweep: Auto.
3. Average measurements: RBW = 1MHz, VBW = 10 Hz, Sweep: Auto.
4. Measurement Level = Reading Level + Correct Factor.
5. Correct Factor = Antenna factor + Cable loss – Amplifier gain.
6. The average measurement was not performed when the peak measured data under the limit of average detection.
7. The emission levels of other frequencies are very lower than the limit and not show in test report.
8. No emission found between lowest internal used/generated frequency to 30MHz.

5. RF Antenna Conducted Test

5.1. Test Equipment

	Equipment	Manufacturer	Model No./Serial No.	Last Cal.
	Spectrum Analyzer	R&S	FSP40 / 100170	Jun., 2014
	Spectrum Analyzer	Agilent	E4407B / US39440758	Jun., 2014
X	Spectrum Analyzer	Agilent	N9010A / MY48030495	Apr., 2014

Note: 1. All equipments are calibrated every one year.
 2. The test instruments Marked “X” are used to measure the final test results.

5.2. Test Setup

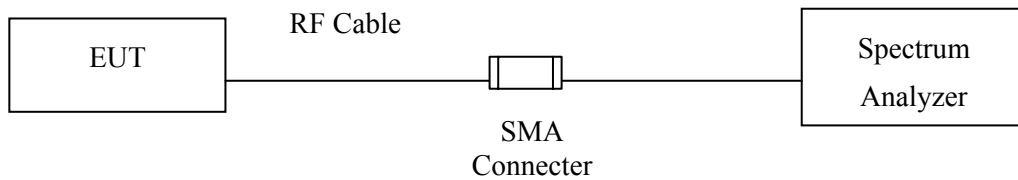

5.3. Limits

According to FCC Section 15.247(d). In any 100 kHz bandwidth outside the frequency band in which the spread spectrum or digitally modulated intentional radiator is operating, the radio frequency power that is produced by the intentional radiator shall be at least 20 dB below that in the 100 kHz bandwidth within the band that contains the highest level of the desired power, based on either an RF conducted or measurement, provided the transmitter demonstrates compliance with the peak conducted power limits. If the transmitter complies with the conducted power limits based on the use of RMS averaging over a time interval, the attenuation required under this paragraph shall be 30 dB instead of 20 dB.

5.4. Test Procedure

The EUT was tested according to DTS test procedure of KDB558074 for compliance to FCC 47CFR 15.247 requirements.

5.5. Uncertainty

± 150Hz

5.6. Test Result of RF Antenna Conducted Test

Product : VoIP Phone
 Test Item : RF Antenna Conducted Test
 Test Site : No.3 OATS
 Test Mode : Mode 1: Transmit - BLE (GFSK)

Figure Channel 00:

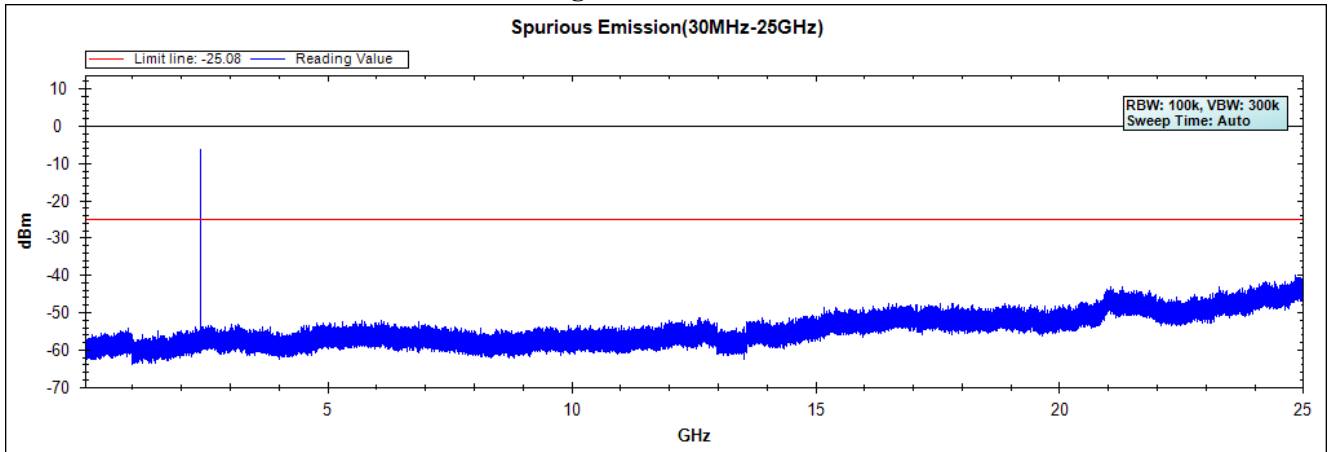

Figure Channel 19:

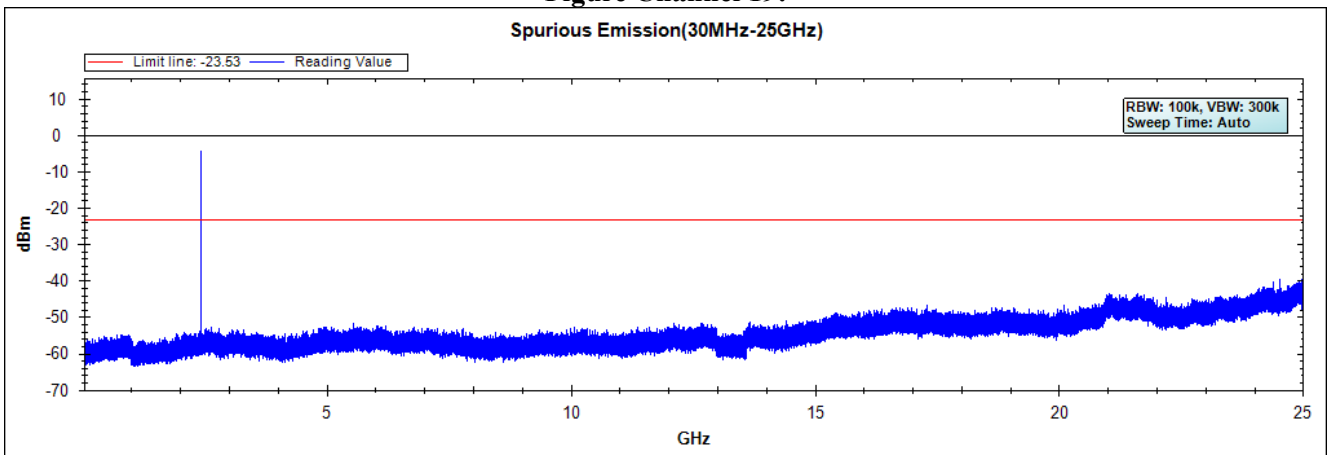
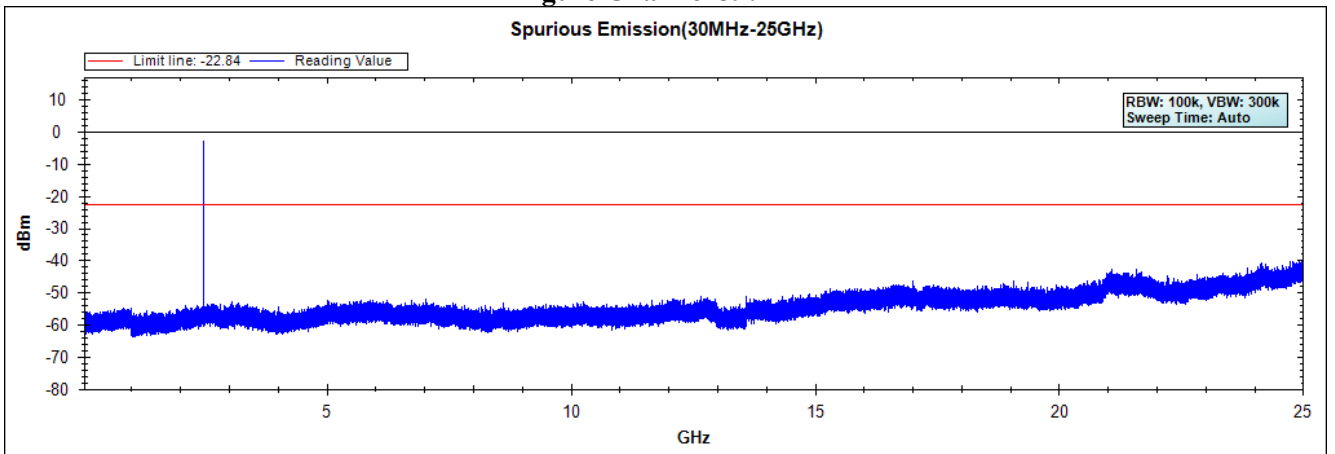

Figure Channel 39:



Note: The above test pattern is synthesized by multiple of the frequency range.

6. Band Edge

6.1. Test Equipment

RF Radiated Measurement:

The following test equipments are used during the band edge tests:

Test Site	Equipment	Manufacturer	Model No./Serial No.	Last Cal.
☒ Site # 3	Bilog Antenna	Schaffner Chase	CBL6112B/2673	Sep., 2014
	X Horn Antenna	Schwarzbeck	BBHA9120D/D305	Sep., 2014
	Horn Antenna	Schwarzbeck	BBHA9170/208	Jul., 2014
	X Pre-Amplifier	Agilent	8447D/2944A09549	Sep., 2014
	X Spectrum Analyzer	Agilent	E4407B / US39440758	May, 2014
	Test Receiver	R & S	ESCS 30/ 825442/018	Sep., 2014
	X Coaxial Cable	QuieTek	QTK-CABLE/ CAB5	Feb., 2014
	X Controller	QuieTek	QTK-CONTROLLER/ CTRL3	N/A
	X Coaxial Switch	Anritsu	MP59B/6200265729	N/A

- Note:
1. All equipments are calibrated every one year.
 2. The test instruments marked by “X” are used to measure the final test results.

6.2. Test Setup

RF Radiated Measurement:

Above 1GHz

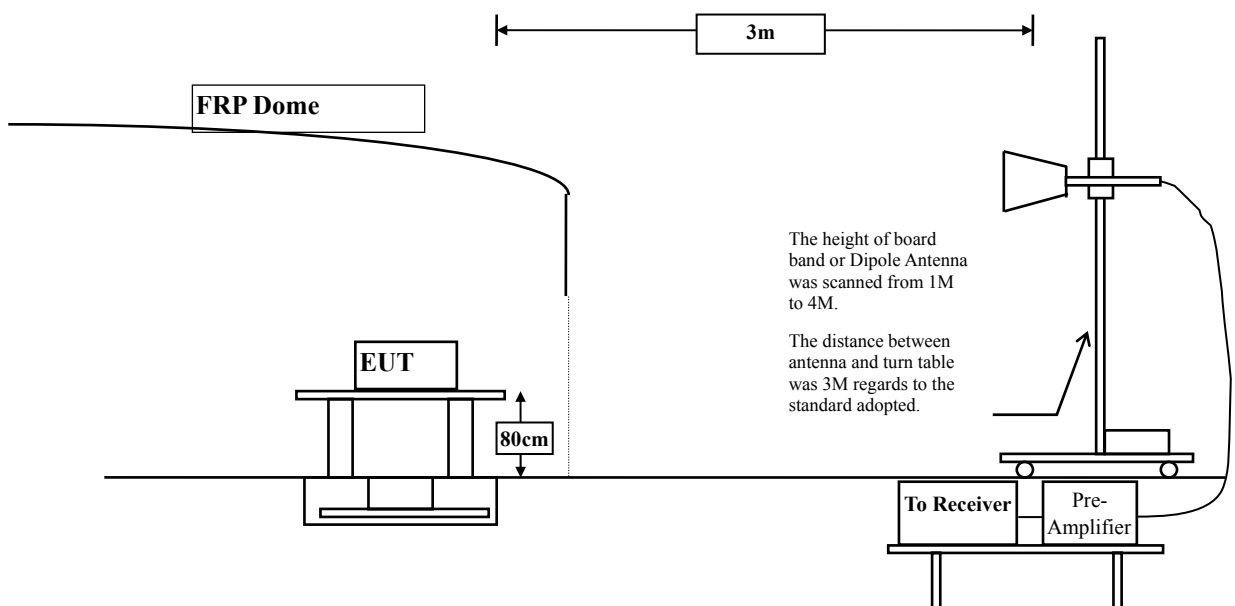

6.3. Limit

In any 100 kHz bandwidth outside the frequency band in which the spread spectrum intentional radiator is operating, the radio frequency power that is produced by the intentional radiator shall be at least 20 dB below that in the 100 kHz bandwidth within the band that contains the highest level of the desired power, based on either an RF conducted or a radiated measurement. Attenuation below the general limits specified in Section 15.209(a) is not required. In addition, radiated emissions which fall in the restricted bands, as defined in Section 15.205(a), must also comply with the radiated emission limits specified in Section 15.209(a) (see Section 15.205(c)).

6.4. Test Procedure

The EUT and its simulators are placed on a turn table which is 0.8 meter above ground. The turn table can rotate 360 degrees to determine the position of the maximum emission level. The EUT was positioned such that the distance from antenna to the EUT was 3 meters.

The antenna can move up and down between 1 meter and 4 meters to find out the maximum emission level.

Both horizontal and vertical polarization of the antenna are set on measurement. In order to find the maximum emission, all of the interface cables must be manipulated according to ANSI C63.10:2009 on radiated measurement.

The bandwidth below 1GHz setting on the field strength meter is 120 kHz, above 1GHz are 1 MHz. The EUT was setup to ANSI C63.10, 2009.

6.5. Uncertainty

- ± 3.9 dB above 1GHz
- ± 3.8 dB below 1GHz

6.6. Test Result of Band Edge

Product : VoIP Phone
 Test Item : Band Edge
 Test Site : No.3 OATS
 Test Mode : Mode 1: Transmit - BLE (GFSK) (2402MHz)

RF Radiated Measurement (Horizontal):

Channel No.	Frequency (MHz)	Correct Factor (dB)	Reading Level (dBμV)	Emission Level (dBμV/m)	Peak Limit (dBμV/m)	Average Limit (dBμV/m)	Result
00 (Peak)	2390.000	-2.687	42.272	39.585	74.00	54.00	Pass
00 (Peak)	2400.000	-2.660	60.235	57.575	--	--	--
00 (Peak)	2402.300	-2.657	90.476	87.819	--	--	--
00 (Average)	2390.000	-2.687	30.784	28.097	74.00	54.00	Pass
00 (Average)	2400.000	-2.660	38.997	36.337	--	--	--
00 (Average)	2402.100	-2.657	68.631	65.974	--	--	--

Figure Channel 00: Horizontal (Peak)

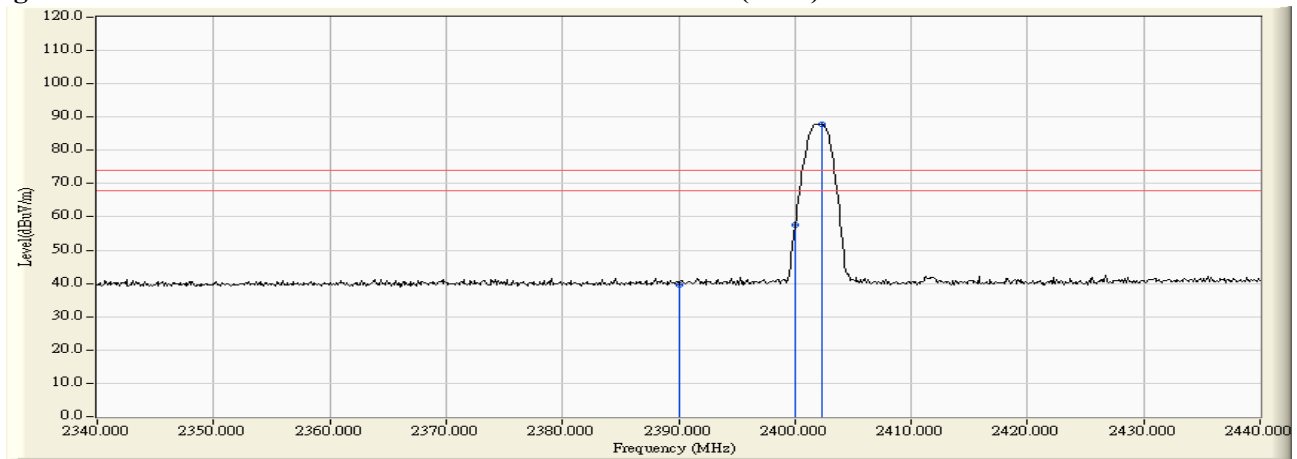
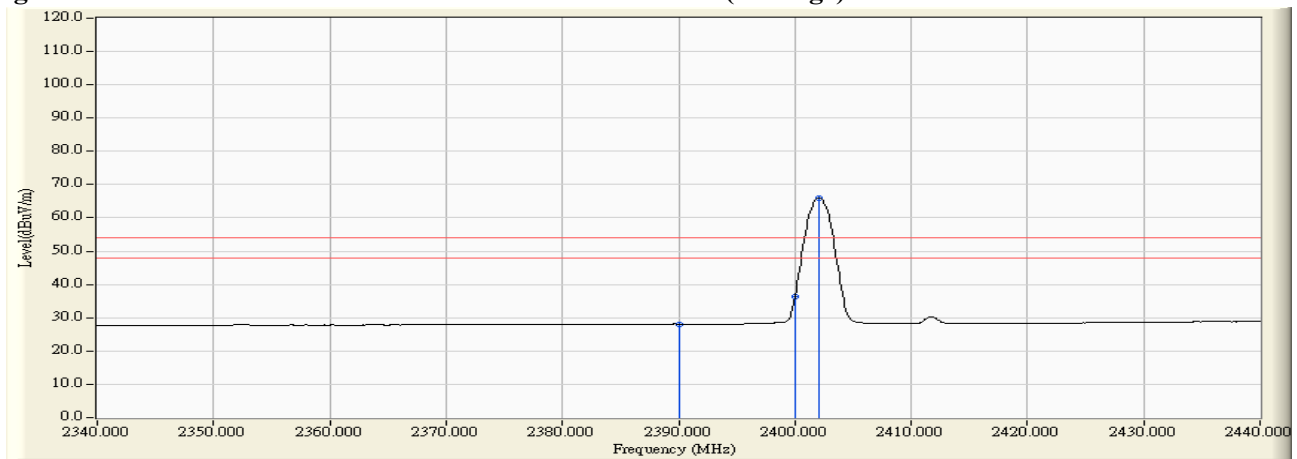

Figure Channel 00: Horizontal (Average)



Note:

1. All readings above 1GHz are performed with peak and/or average measurements as necessary.
2. Peak measurements: RBW = 1MHz, VBW = 3 MHz, Sweep: Auto.
3. Average measurements: RBW = 1MHz, VBW = 10 Hz, Sweep: Auto.
4. “ * ”, means this data is the worst emission level.
5. Measurement Level = Reading Level + Correct Factor.
6. The average measurement was not performed when the peak measured data under the limit of average detection.

Product : VoIP Phone
 Test Item : Band Edge
 Test Site : No.3 OATS
 Test Mode : Mode 1: Transmit - BLE (GFSK) (2402MHz)

RF Radiated Measurement (Vertical):

Channel No.	Frequency (MHz)	Correct Factor (dB)	Reading Level (dBμV)	Emission Level (dBμV/m)	Peak Limit (dBμV/m)	Average Limit (dBμV/m)	Result
00 (Peak)	2390.000	-4.159	42.763	38.604	74.00	54.00	Pass
00 (Peak)	2400.000	-4.171	53.713	49.542	--	--	--
00 (Peak)	2402.300	-4.171	84.380	80.209	--	--	--
00 (Average)	2390.000	-4.159	30.763	26.604	74.00	54.00	Pass
00 (Average)	2400.000	-4.171	36.466	32.295	--	--	--
00 (Average)	2402.100	-4.171	64.814	60.643	--	--	--

Figure Channel 00: Vertical (Peak)

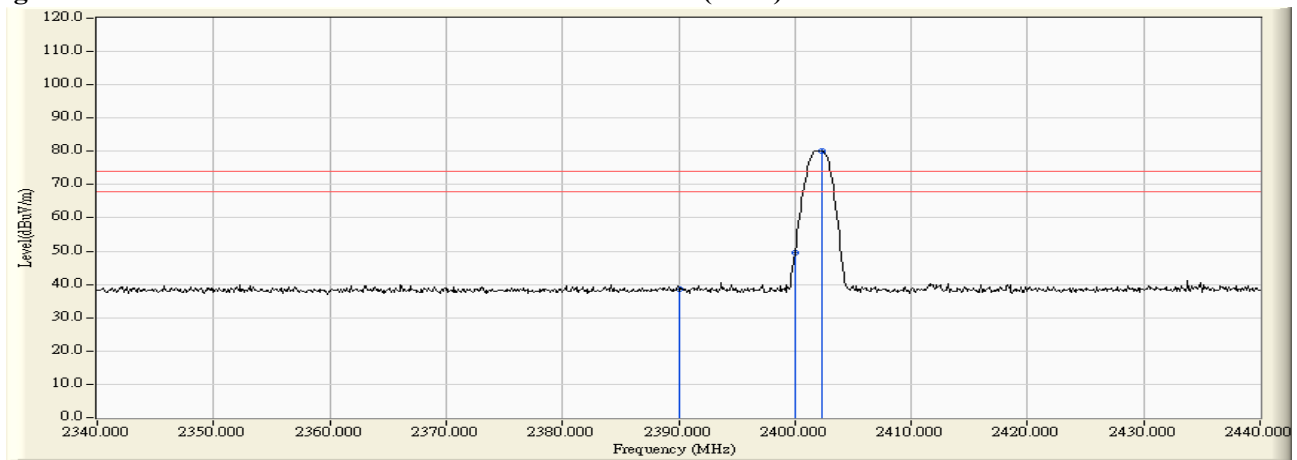
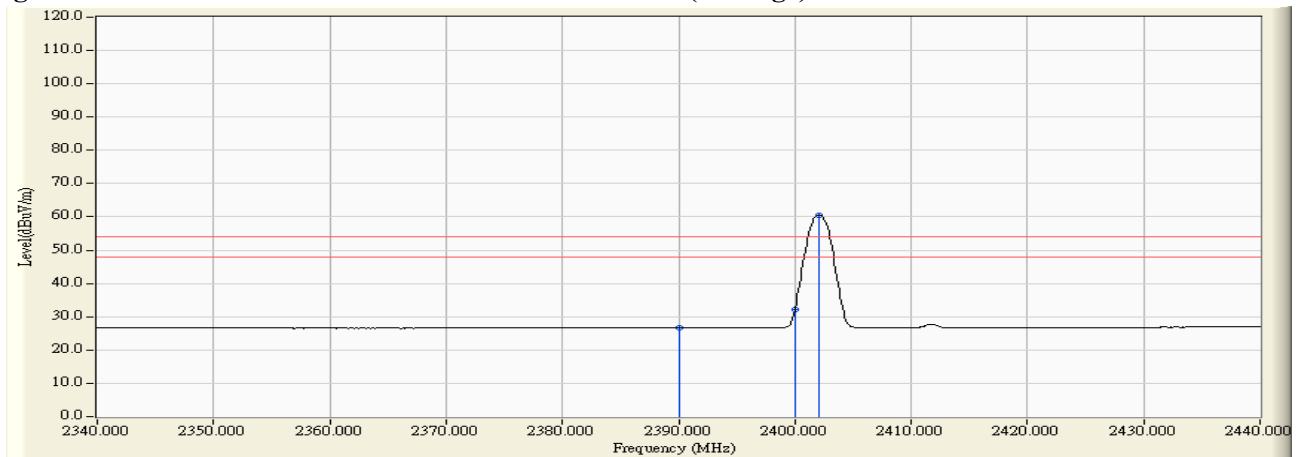

Figure Channel 00: Vertical (Average)



Note:

1. All readings above 1GHz are performed with peak and/or average measurements as necessary.
2. Peak measurements: RBW = 1MHz, VBW = 3 MHz, Sweep: Auto.
3. Average measurements: RBW = 1MHz, VBW = 10 Hz, Sweep: Auto.
4. “ * ”, means this data is the worst emission level.
5. Measurement Level = Reading Level + Correct Factor.
6. The average measurement was not performed when the peak measured data under the limit of average detection.

Product : VoIP Phone
 Test Item : Band Edge
 Test Site : No.3 OATS
 Test Mode : Mode 1: Transmit - BLE (GFSK) (2480MHz)

RF Radiated Measurement (Horizontal):

Channel No.	Frequency (MHz)	Correct Factor (dB)	Reading Level (dBμV)	Emission Level (dBμV/m)	Peak Limit (dBμV/m)	Average Limit (dBμV/m)	Result
39 (Peak)	2479.800	-2.605	96.733	94.128	--	--	--
39 (Peak)	2483.500	-2.601	45.236	42.634	74.00	54.00	Pass
39 (Peak)	2484.100	-2.602	46.177	43.576	74.00	54.00	Pass
39 (Average)	2480.000	-2.605	73.011	70.406	--	--	--
39 (Average)	2483.500	-2.601	32.615	30.013	74.00	54.00	Pass

Figure Channel 39: Horizontal (Peak)

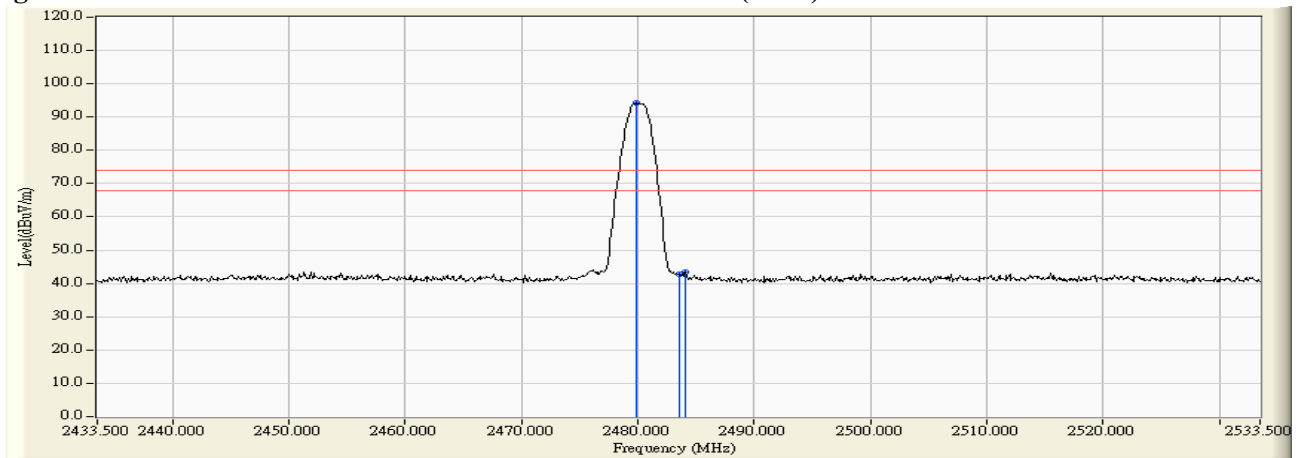
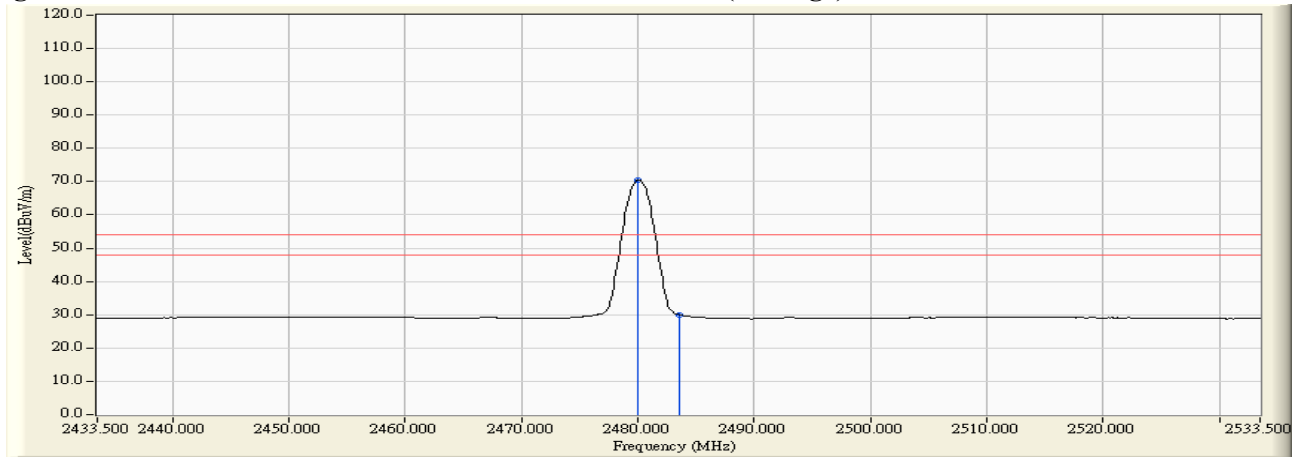

Figure Channel 39: Horizontal (Average)



Note:

1. All readings above 1GHz are performed with peak and/or average measurements as necessary.
2. Peak measurements: RBW = 1MHz, VBW = 3 MHz, Sweep: Auto.
3. Average measurements: RBW = 1MHz, VBW = 10 Hz, Sweep: Auto.
4. “ * ”, means this data is the worst emission level.
5. Measurement Level = Reading Level + Correct Factor.
6. The average measurement was not performed when the peak measured data under the limit of average detection.

Product : VoIP Phone
 Test Item : Band Edge
 Test Site : No.3 OATS
 Test Mode : Mode 1: Transmit - BLE (GFSK) (2480MHz)

RF Radiated Measurement (Vertical):

Channel No.	Frequency (MHz)	Correct Factor (dB)	Reading Level (dBμV)	Emission Level (dBμV/m)	Peak Limit (dBμV/m)	Average Limit (dBμV/m)	Result
39 (Peak)	2479.800	-3.978	89.107	85.129	--	--	--
39 (Peak)	2483.500	-3.966	42.014	38.047	74.00	54.00	Pass
39 (Peak)	2486.000	-3.959	43.817	39.858	74.00	54.00	Pass
39 (Average)	2480.100	-3.977	67.914	63.937	--	--	--
39 (Average)	2483.500	-3.966	31.075	27.108	74.00	54.00	Pass

Figure Channel 39: Vertical (Peak)

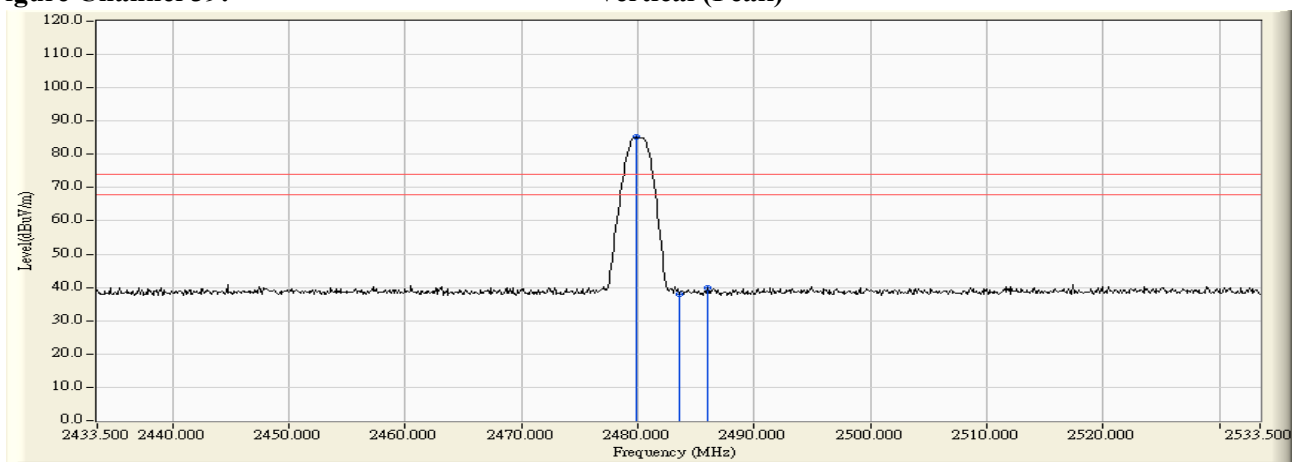
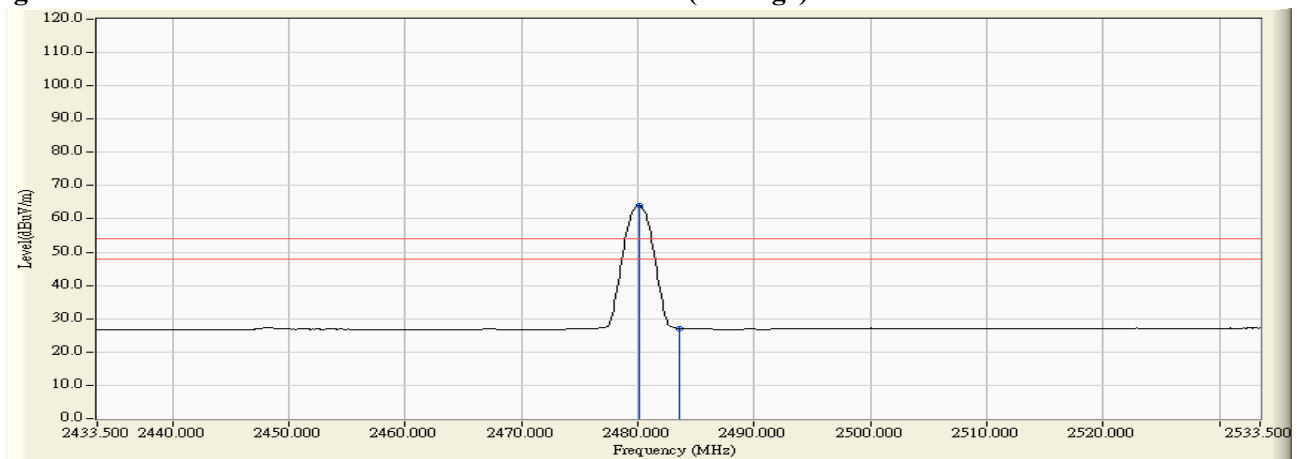

Figure Channel 39: Vertical (Average)



Note:

1. All readings above 1GHz are performed with peak and/or average measurements as necessary.
2. Peak measurements: RBW = 1MHz, VBW = 3 MHz, Sweep: Auto.
3. Average measurements: RBW = 1MHz, VBW = 10 Hz, Sweep: Auto.
4. “ * ”, means this data is the worst emission level.
5. Measurement Level = Reading Level + Correct Factor.
6. The average measurement was not performed when the peak measured data under the limit of average detection.

7. Occupied Bandwidth (6dB BW)

7.1. Test Equipment

	Equipment	Manufacturer	Model No./Serial No.	Last Cal.
	Spectrum Analyzer	R&S	FSP40 / 100170	Jun., 2014
	Spectrum Analyzer	Agilent	E4407B / US39440758	Jun., 2014
X	Spectrum Analyzer	Agilent	N9010A / MY48030495	Apr., 2014

Note:

1. All equipments are calibrated with traceable calibrations. Each calibration is traceable to the national or international standards.
2. The test instruments marked with “X” are used to measure the final test results.

7.2. Test Setup

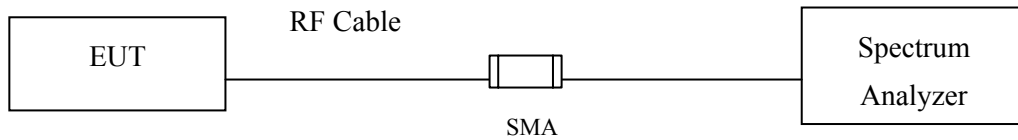

7.3. Limits

The minimum bandwidth shall be at least 500 kHz.

7.4. Test Procedure

The EUT was setup according to ANSI C63.10 2009; tested according to DTS test procedure of KDB558074 for compliance to FCC 47CFR 15.247 requirements.

Set RBW = 1-5% of the emission bandwidth, $VBW \geq 3 * RBW$

7.5. Uncertainty

$\pm 150\text{Hz}$

7.6. Test Result of Occupied Bandwidth

Product : VoIP Phone
 Test Item : Occupied Bandwidth Data
 Test Site : No.3 OATS
 Test Mode : Mode 1: Transmit - BLE (GFSK) (2402MHz)

Channel No.	Frequency (MHz)	Measurement Level (kHz)	Required Limit (kHz)	Result
00	2402	740	>500	Pass

Figure Channel 00:

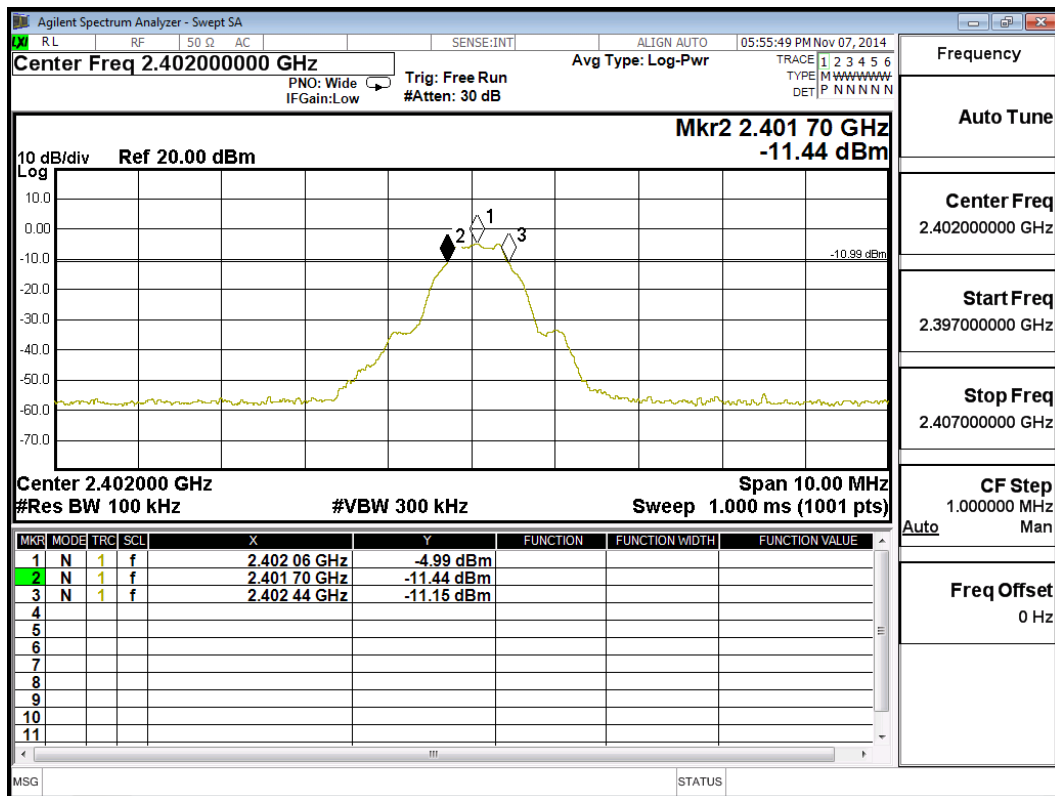

Product : VoIP Phone
 Test Item : Occupied Bandwidth Data
 Test Site : No.3 OATS
 Test Mode : Mode 1: Transmit - BLE (GFSK) (2440MHz)

Channel No.	Frequency (MHz)	Measurement Level (kHz)	Required Limit (kHz)	Result
19	2440	730	>500	Pass

Figure Channel 19:

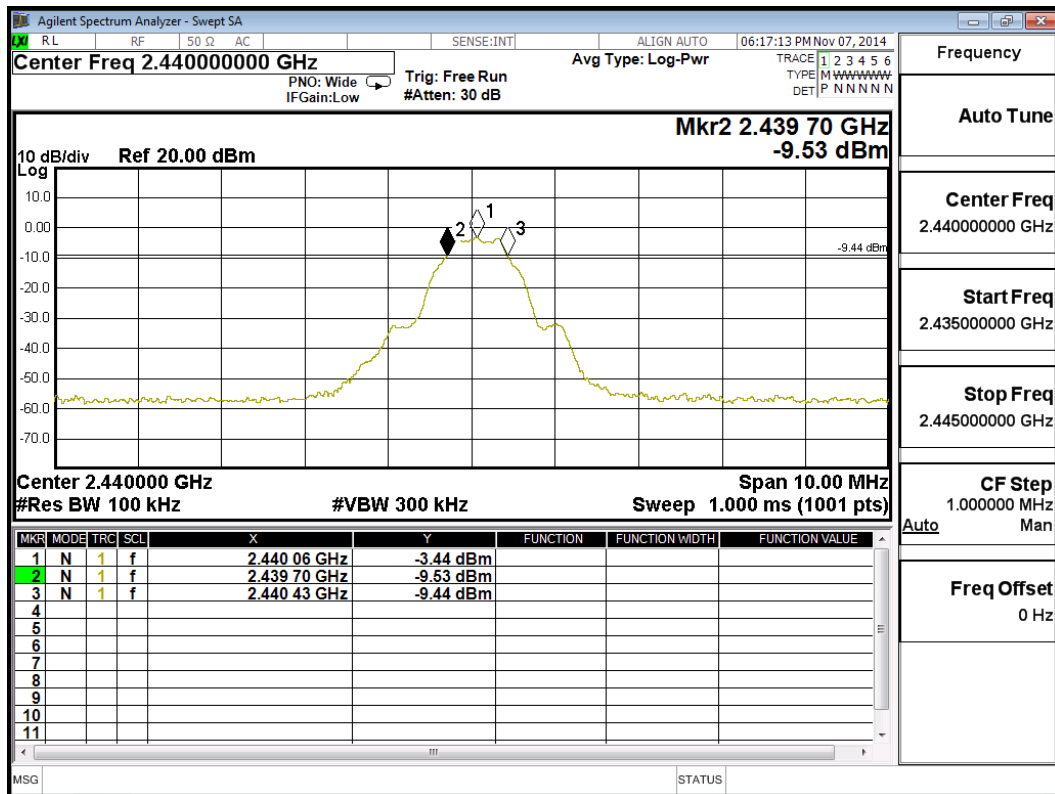

Product : VoIP Phone
 Test Item : Occupied Bandwidth Data
 Test Site : No.3 OATS
 Test Mode : Mode 1: Transmit - BLE (GFSK) (2480MHz)

Channel No.	Frequency (MHz)	Measurement Level (kHz)	Required Limit (kHz)	Result
39	2480	740	>500	Pass

Figure Channel 39:

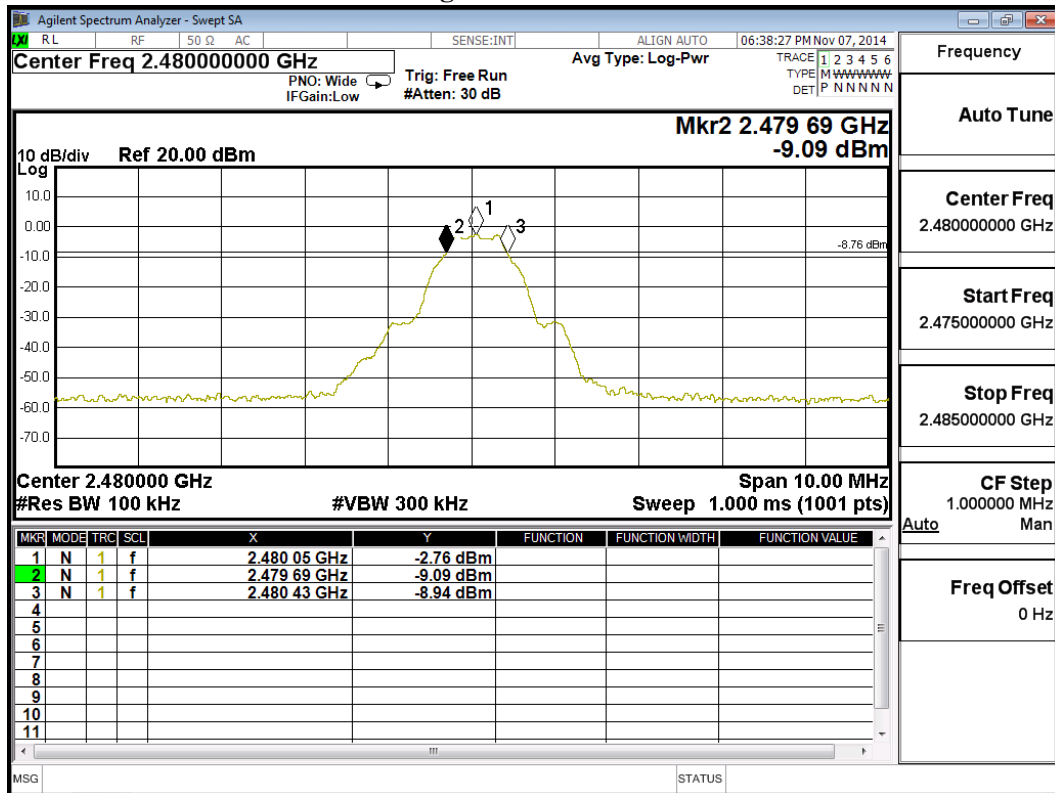

8. Power Density

8.1. Test Equipment

	Equipment	Manufacturer	Model No./Serial No.	Last Cal.
	Spectrum Analyzer	R&S	FSP40 / 100170	Jun., 2014
	Spectrum Analyzer	Agilent	E4407B / US39440758	Jun., 2014
X	Spectrum Analyzer	Agilent	N9010A / MY48030495	Apr., 2014

Note:

1. All equipments are calibrated with traceable calibrations. Each calibration is traceable to the national or international standards.
2. The test instruments marked with “X” are used to measure the final test results.

8.2. Test Setup

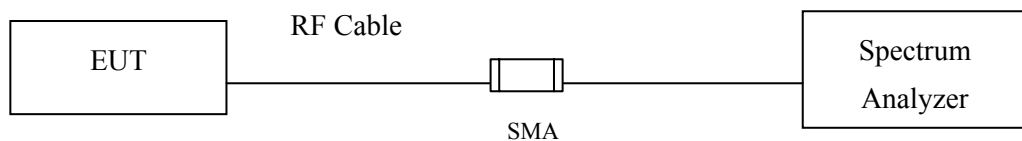

8.3. Limits

The transmitted power density averaged over any 1 second interval shall not be greater +8dBm in any 3kHz bandwidth.

8.4. Test Procedure

The EUT was setup according to ANSI C63.10: 2009, the maximum power spectral density using KDB 558074 section 10.2 PKPSD (peak PSD) method.

8.5. Uncertainty

± 1.27 dB

8.6. Test Result of Power Density

Product : VoIP Phone
 Test Item : Power Density Data
 Test Site : No.3 OATS
 Test Mode : Mode 1: Transmit - BLE (GFSK) (2402MHz)

Channel No.	Frequency (MHz)	Measure Level (dBm)	Limit (dBm)	Result
00	2402	-5.08	< 8dBm	Pass

Figure Channel 00:

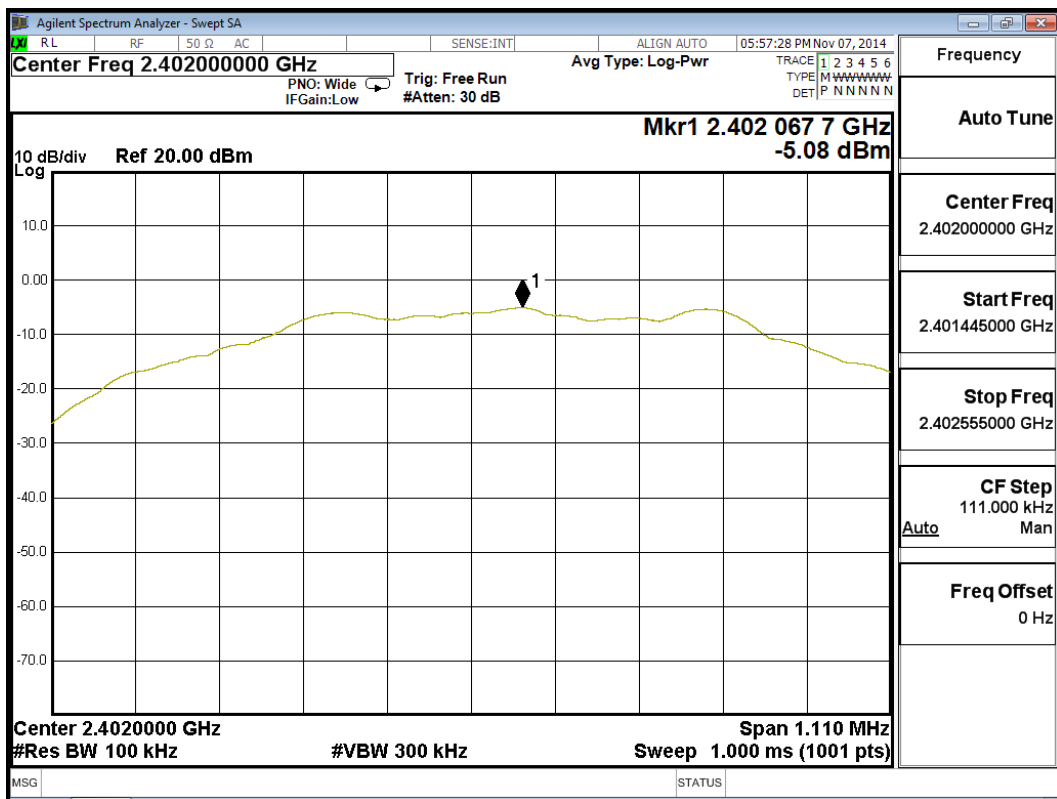

Product : VoIP Phone
 Test Item : Power Density Data
 Test Site : No.3OATS
 Test Mode : Mode 1: Transmit - BLE (GFSK) (2440MHz)

Channel No.	Frequency (MHz)	Measurement Level (dBm)	Required Limit (dBm)	Result
19	2440	-3.53	< 8dBm	Pass

Figure Channel 19:

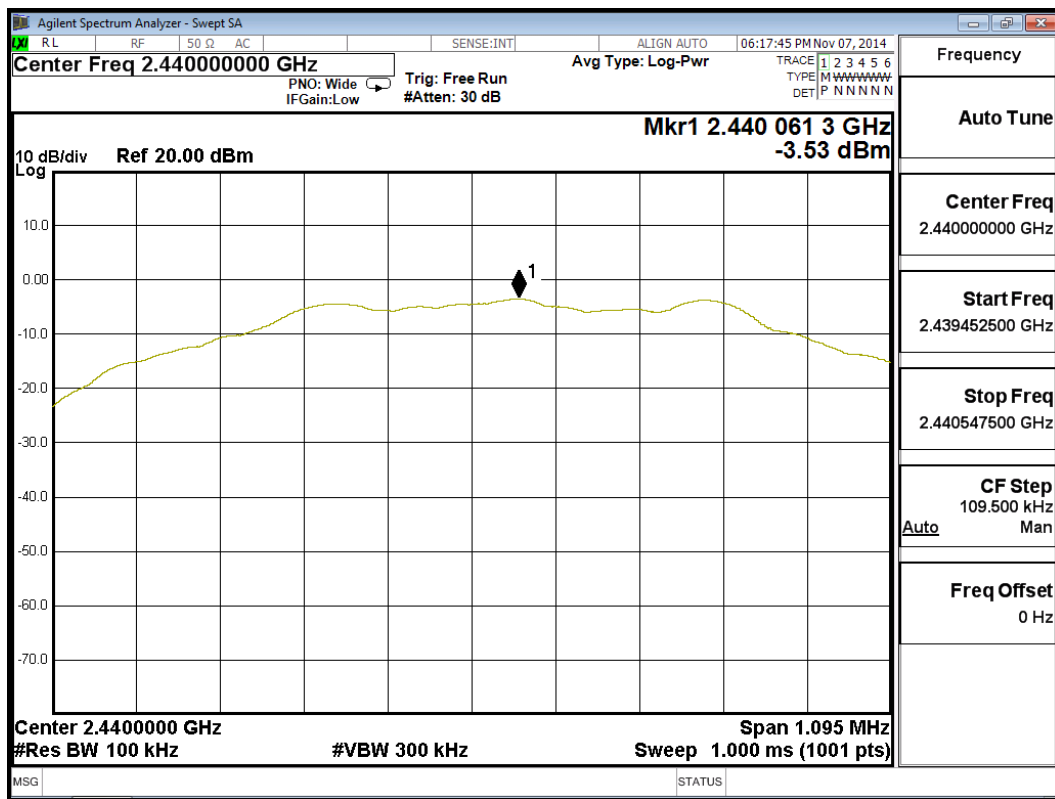

Product : VoIP Phone
 Test Item : Power Density Data
 Test Site : No.3 OATS
 Test Mode : Mode 1: Transmit - BLE (GFSK) (2480MHz)

Channel No.	Frequency (MHz)	Measurement Level (dBm)	Required Limit (dBm)	Result
39	2480	-2.84	< 8dBm	Pass

Figure Channel 39:

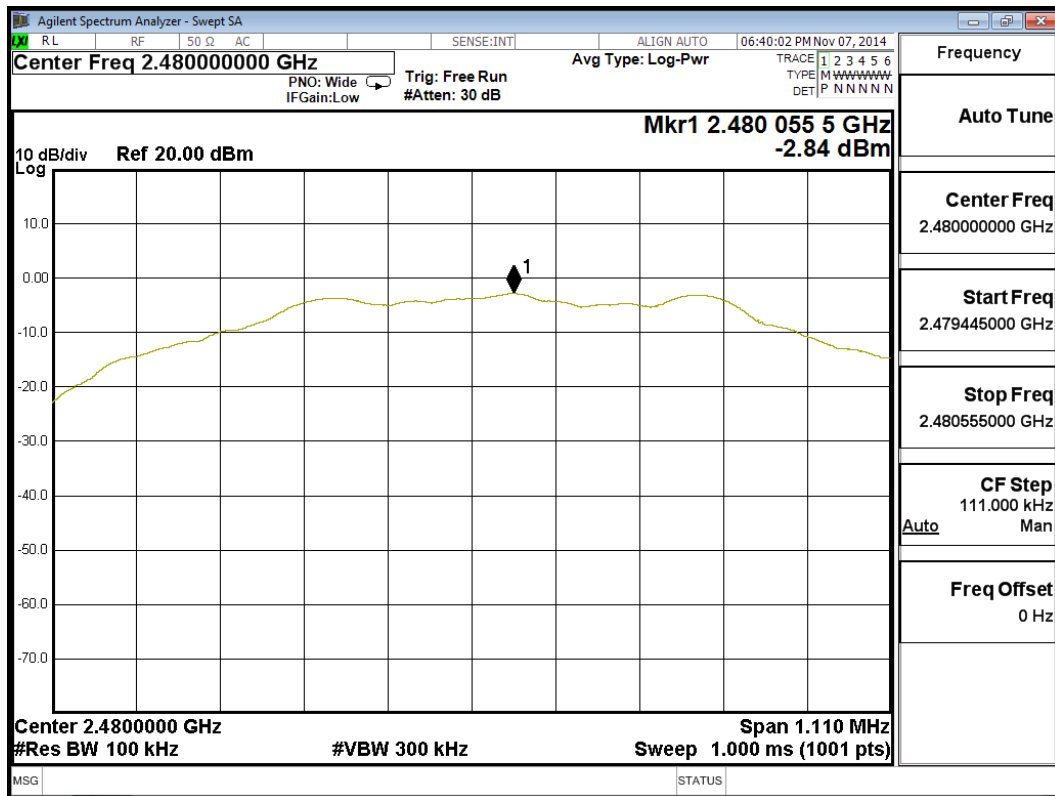

9. EMI Reduction Method During Compliance Testing

No modification was made during testing.

Attachment 1: EUT Test Photographs

Attachment 2: EUT Detailed Photographs